

NRS 049-2:2024

Edition 3

**ADVANCED METERING
INFRASTRUCTURE — REQUIREMENTS
FOR SMART METERING SYSTEMS**

**PART 2: REQUIREMENTS FOR SMART
METERING EQUIPMENT**

This document is not a South African National Standard



This rationalized user specification is issued by
the Technical Governance Department, Eskom,
on behalf of the
User Group given in the foreword
and is not a standard as contemplated in the Standards Act, 1993 (Act No. 29 of 1993).

Table of changes

Change No.	Date	Text affected

Correspondence to be directed to

The Technical Governance Manager
Technical Governance
Eskom
Private Bag X13
Halfway House 1685

Telephone : (011) 651 6830
Fax : (086) 667 3084
E-mail : nrs@eskom.co.za

Website : <https://scot.eskom.co.za>

NRS 049-2:2024

Foreword

This part of NRS 049 was prepared by a working group which, at the time of publication of this edition, comprised the following members:

Brandow F	City of Ekurhuleni
Brooks R	Eskom
Groenewald H	Eskom
Makwarela E	Eskom
Malan C	City of Cape Town
Mashinini G	eThekweni Municipality
Mohlala M	City Power Johannesburg (SOC) Ltd
Nundlal V (Project Leader)	NRS Project Management Agency (NRS PMA)
Omar M	Eskom
Papi S	Eskom
Van Jaarsveld W	Nelson Mandela Bay Municipality

A Manufacturers' Interest Group (MIG) was consulted on the contents of this Part of NRS 049, and its comments were incorporated where the working group was in agreement. The MIG comprised the following members:

STS experts	STS Association
Val Rengecas	SANC TC13 experts
Meter Manufacturers	South African Metering Industry Association

This guideline was approved by the NRS Management Committee which, at the time of publication, comprised the following members:

Padayachee V (Chairman)	Association of Municipal Electricity Utilities of Southern Africa (AMEU)
Dlamini J	South African Bureau of Standards (SABS)
Ferrier R	Buffalo City Metropolitan Municipality
Graham J	City of Cape Town
Kgopa M	National Energy Regulator of South Africa (NERSA)
Lamour B	Nelson Mandela Bay Municipality
Naicker J	NRS Project Management Agency (NRS PMA)
Naidoo L	Eskom Transmission
Nkambule T (Ms)	Eskom Distribution
Ramnarain V	eThekweni Municipality
Raseboka S	City Power Johannesburg (SOC) Ltd
Rasetlola M	City of Tshwane
Rikhotso C	City of Ekurhuleni

NRS 049 consists of the following Parts under the general title *Advanced Metering Infrastructure*:

Part 1: Framework for Standardisation

Part 2: Requirements for Smart Metering Equipment

Part 3: Requirements for a Head End System

Part 4: Auxiliary equipment (ACD/Water meters)

Part 5: Data Exchange Requirements

Contents

	Page
Foreword	3
1. Scope	4
2. Normative references	5
3. Terms, definitions and abbreviations	6
3.1 Terms and definitions	6
3.2 Abbreviations	6
4. General requirements for the meter CIU and NG/DC	7
4.1 General	7
4.2 General test requirements	7
4.3 Construction requirements	8
4.4 Climatic requirements	8
4.5 Electrical requirements	8
4.6 Software	8
4.7 Firmware upgrades	9
5. Particular requirements for meters	9
5.1 General	9
5.2 Construction requirements	9
5.3 Climatic requirements	11
5.4 Electrical requirements	11
5.5 Metering accuracy requirements	11
5.6 Time keeping requirements	12
5.7 Communication interfaces	13
5.8 Functional requirements	13
5.9 Functional requirements for the meter's load control capability	14
6. Particular requirements for the bulk meter	16
6.1 General	16
7. Particular requirements for customer interface units	17
7.1 General	17
7.2 Construction requirements	17
7.3 Electrical requirements	17
7.4 Display	17
7.5 User manual	18
7.6 Functional requirements for the displays (Meter and customer interface unit)	18
8. Particular requirements for the network gateway/data concentrator	20
8.1 General	20
8.2 Construction requirements	20
8.3 Electrical requirements	20
8.4 Time keeping requirements	21
8.5 Communication interfaces	21
9. Particular requirements for modems	21
9.1 General	21
9.2 Mechanical requirements	21
9.3 Transceiver	22
9.4 Network communications	22
9.5 Network settings	22
9.6 Identity modules	22
9.7 Modem indications	23
9.8 Diagnostics	23
9.9 Modem security	24
9.10 Power supply	24
9.11 External connectors	24

Annex A – Use cases for smart meters.....26
Annex B – Dimension for DIN rail mounted meters39

This page intentionally left blank

ADVANCED METERING INFRASTRUCTURE — REQUIREMENT FOR SMART METERING SYSTEMS

Part 2: Requirements for smart metering equipment

1. Scope

This part of NRS 049 covers the requirements of AMI smart metering equipment as indicated in the figure below.

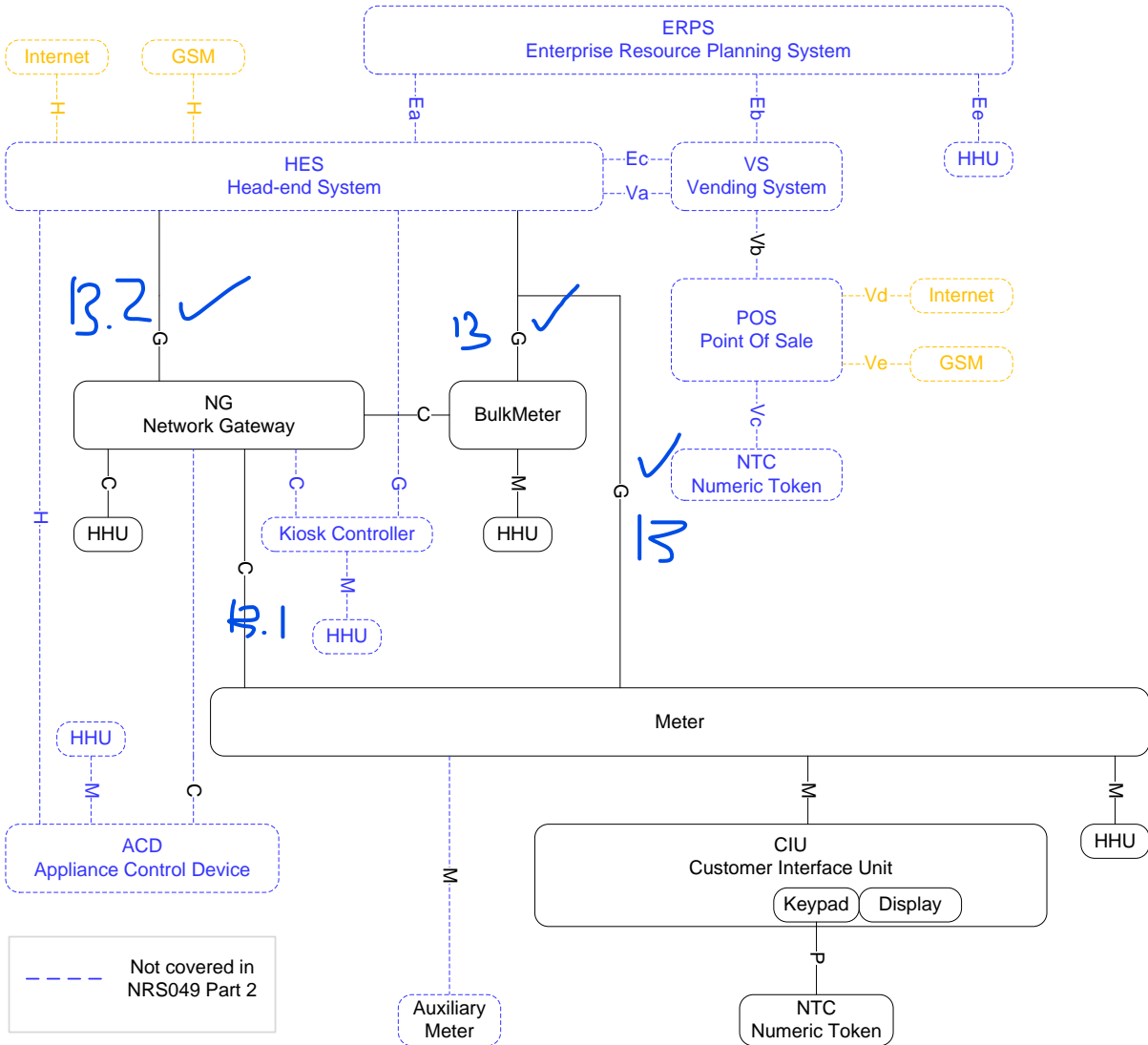

Figure 1 — AMI smart metering equipment

- a) This specification defines requirements for the following devices
 - i) network gateway / data concentrator,
 - ii) meter,
 - iii) customer interface unit,
 - iv) hand-held unit, and
 - v) modem.

NOTE This part of NRS 049 will not specify communication interfaces to all ancillary equipment. Details will be provided in a different part of NRS 049.

- b) type test requirements for devices are based on existing standards such as IEC 62052 series, IEC 62053 series, IEC 62054 series, IEC 62055 series and IEC 62056 series.

Requirements for devices that are installed outside of buildings and not inside a protective enclosure are not in the scope of this specification.

2. Normative references

The following documents, in whole or in part, are normatively referenced in this specification and are indispensable for its application. For dated references, only the edition cited applies. For undated references, the latest edition of the referenced document (including any amendments) applies.

BS 7856:2013, *Code of practice for special design and other features of alternating current watt-hour meters for active energy (MID accuracy classes A and B) for use in the UK.*

IEC 62055-31:2022, *Electricity metering — Payment systems — Part 31: Particular requirements — Static payment meters for active energy (classes 0,5, 1 and 2)*

IEC 62052-11:2020, *Electricity metering equipment (ac) — General requirements, tests and test conditions — Part 11: Metering equipment.*

IEC 62052-21:2004/AMD1:2016, *Electricity metering equipment (ac) — general requirements, tests and test conditions — Part 21: Tariff and load control equipment.*

IEC 62056-21:2002, *Electricity metering - Data exchange for meter reading, tariff and load control: Direct local data exchange*

IEC 62055-41:2018, *Electricity metering — Payment systems — Part 41: Standard transfer specification (STS) - Application layer protocol for one-way token carrier systems.*

SANS 164-1:2021, *Plug and socket-outlet systems for household and similar purposes for use in South Africa — Part 1: Conventional system, 16 A 250 V a.c.*

SANS 474:2022, *Electrical metering – standard requirements.*

SANS 10142-1:2021, *Wiring of premises – Part 1: Low voltage installations.*

SANS 60950-1:2014, *Information technology equipment safety*

3GPP TS 51.010-1, *Mobile station (MS) conformance specification – Part 1*

ETSI EN 301 511, *Harmonized standard for mobile stations in the GSM 900 and GSM 1800 bands covering essential requirements under article 3.2 of the R&TTE directive (1999/5/EC)*

GCF CC, *Global Certification Forum – certification criteria*

ETSI EN 301 489-1 & 7, *Electromagnetic compatibility (EMC) standard for radio equipment and services*

NRS 049-5-1, *Companion specification requirements (under development)*

NRS 096-1, *Electricity metering — Ancillary specifications — Part 1: The sealing of electricity meters.*

DLMS UA 1001-1, *Qualification for Compliance and Compatibility Process*

3. Terms, definitions and abbreviations

For the purposes of this specification, the terms and definitions given in SANS474, IEC 62052-11, SANS 1524-1 and the following apply.

3.1 Terms and definitions

accredited laboratories: The laboratory must be accredited appropriately and recognised internationally by an accreditation body which is a member of the ILAC mutual recognition scheme]

import energy: Energy that flows from the network to the customer's load

export energy: Energy generated on the customer's side that flows into the network

ERPS: A collective term for all systems outside of the HES that communicate with meters or other end devices via the HES, for example: outage management system, asset management system, customer information system, load control system, meter data management system, demand response system, etc.

HES: In general, the central communications and configuration command centre of the metering system located at the top of the hierarchy of equipment deployed within the metering system

bulk meter: A bulk meter is simply another instance of meter having exactly the same functional properties, except that it does not have accounting and disconnect functions

statistical metering: Statistical metering is defined as interval-based energy flow metering that is not directly used for tariff purposes. Statistical meters are installed to measure load flows that do not attract billing, i.e. to determine load flow patterns in circuits that do not supply direct customers

multi-device installation: A meter installation where the measuring element(s), registers, load switches and auxiliary equipment are not contained in a single enclosure

client: A DLMS/COSEM Client as defined in IEC 62056-5-3

NOTE This would be any device in NRS049 to which this role is assigned.

hand-held unit: Portable device used for meter reading and/or equipment configuration

type testing: Test of one or more samples of equipment (or parts of equipment) made to a particular design to show that the design and construction meet one or more requirements of this specification

NOTE 1 This is an amplification of the IEC 60050-151:2001, 151-16-16 definition to cover design as well as construction.

[source: IEC 61010-1:2010, 3.4.1]

NOTE 2 For the purpose of this specification, type testing is carried out on equipment to prove compliance with certain specifications and hence its acceptability for the purpose for which it was intended as part of a metering installation.

3.2 Abbreviations

3G: 3rd Generation

BS: British Standard

CA: Certificate Authority

CB: Certification Body

CIU: Customer Interface Unit

COSEM: Companion Specification for Energy Metering
CSD Circuit Switched Data
DC: Data concentrator
DHCPv6: Dynamic Host Configuration Protocol version 6
DIN: Deutsches Institut für Normung (German Institute for Standardisation)
DLMS: Device Language Message Specification
DLMS UA: DLMS User Association
ERPS: Enterprise Resource Planning System
GPRS: General Packet Radio Service
GSM: Global System for Mobile Communications
HDLC: High-Level Data Link Control
HES: Head-End System
HHU: Hand-Held Unit
ICASA: Independent Communications Authority of South Africa
IEEE: Institute of Electrical and Electronics Engineers
L_{IN}: Line In
LNAP: Local Network Access Point
L_{OUT}: Line Out
LTE: Long-Term Evolution
Mbus: Meter Bus
MS: Metering System
NG: Network Gateway
NRS: National Rationalised Specification
NTC: Numeric Token Carrier
PLC: Power Line Carrier
POS: Point of Sale
Q: Quadrant
RF: Radio Frequency
SANS: South African National Standard
STS: Standard Transfer Specification
TCP: Transport Control Protocol
TI: Tariff Index
TOU: Time of Use
UC: Utilisation Category
VAC: Volts AC
VS: Vending System
VTC: Virtual Token Carrier

4. General requirements for the meter CIU and NG/DC

4.1 General

For meter and CIU devices the requirements given in IEC 62055 Part 31 shall apply, except for the particular deviations and additions as given in clauses 6 and 7.

For devices, other than meter and CIU devices, the requirements given in IEC 62052 Part 21 shall apply, except for the particular deviations and additions as given in clause 8.

All communicating devices shall be designed to reliably communicate over the physical location distances as given in the **NRS 049-5-1** specification.

If any statutory specification applies to a device, this shall be stated in the purchase agreement.

4.2 General test requirements

Type test certificates according to SANS (IEC) 62053 Parts 21 and 24, and IEC 62055 Part 31 shall be issued by an accredited laboratory.

A copy of all test certificates and details of tests performed and the approval certificates of the approved test authority shall be submitted with a tender.

Meters shall be certified as DLMS compliant according to DLMS UA requirements and STS-compliant according to IEC 62055 Part 41.

Meters, CIUs and NG/DC shall be certified for the communication type utilised i.e. G3 PLC and/or **WI-Sun**.

Where applicable, ICASA (or equivalent) approval for use in South Africa shall also be obtained.

Compliance to NRS 049-5 companion specification is required.

NOTE Certification to be specified per device.

4.3 Construction requirements

Devices shall comply with the requirements of clause 5 of IEC 62055 Part 31.

Devices shall comply with the requirements of insulating encased equipment of protective class II.

Terminal blocks on devices shall be mounted in such a way that they do not cause undue stress forces on internal circuitry.

4.4 Climatic requirements

Meter and CIU devices that are intended for installation in enclosures located inside buildings shall meet the requirements given in clause 6 of IEC 62055 Part 31.

4.5 Electrical requirements

Devices shall comply with the requirements of clause 7 of IEC 62055 Part 31.

4.5.1 General

The standard reference voltage is 230 V for single phase meters and 400 V phase-to-phase for three-phase meters.

The rated supply frequency shall be 50 Hz.

5.5.2 Dependability and Reliability

All devices shall have a design life of 15 years and the annualised failure rate shall not exceed 2 % per annum.

Requirements for accelerated life tests shall be specified in the purchase agreement.

NOTE The IEC 62059 standards provide methods for the evaluation of reliability.

4.6 Software

The configuration software shall be supplied for all devices.

Security measures, such as a hierarchical password system, shall prevent the configuration information in the meter and the configuration software, from being changed by unauthorized personnel.

4.7 Firmware upgrades

Future versions of firmware shall be made available to the purchaser.

NOTE The commercial conditions under which future versions of firmware will be made available to the purchaser would be subject to negotiation between the parties.

The smart meter shall be capable of receiving, accepting, and installing (in its memory) firmware from an authenticated and authorized HES. For installation of the received and accepted firmware, the smart meter shall use a mechanism that is robust against corruption and loss of data.

It shall not be possible to remotely change the firmware that operates the metrology functions of the meter.

5. Particular requirements for meters

5.1 General

For the purposes of meeting the requirements of IEC 62055 Part 31, the meter shall always be regarded as a payment meter, regardless of whether it is in prepayment mode or in post-payment mode, and both modes shall be tested.

An optical test output shall be provided for calibration purposes as specified in IEC 62052 Part 11. Where provision is made for a kWh and kvarh test output then they shall be at least 20mm apart. Where only a single output test LED is provided it should be configurable for both kWh and kvarh testing.

The meter shall have a port or facility for local meter reading and configuration.

5.2 Construction requirements

5.2.1 Protection against the ingress of dust and water

Meters, or devices in a multi-device installation shall be rated as IP52 for protection against penetration of dust and water.

5.2.2 Dimensions

The maximum dimensions for a single-phase BS footprint meter shall be 210 mm high by 145 mm wide by 110 mm deep.

The maximum dimensions for the DIN-rail single phase meter shall be 155 mm high by 65 mm wide by 110 mm deep. Dimensional diagrams are provided in Annexure B.

The maximum dimensions for a three phase BS footprint meter shall be 330 mm high by 200 mm wide by 110 mm deep.

5.2.3 Terminal arrangement

The requirements for terminal arrangements shall be specified in the purchase agreement and shall comply with one of the following types:

- a) the BS footprint as specified in BS 7856:2017

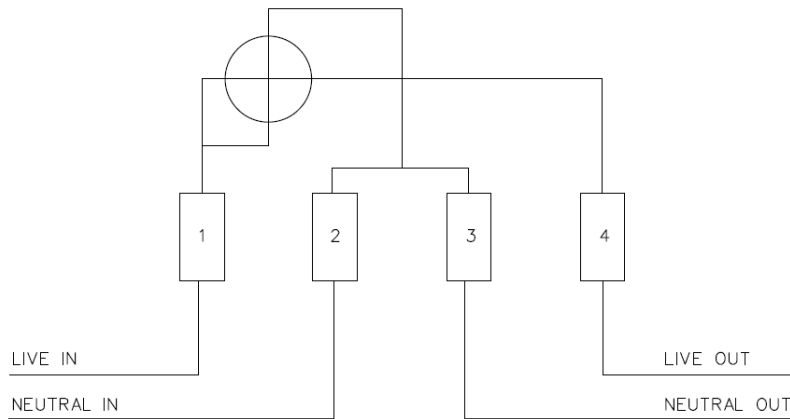

Figure 2 — Single phase whole current meter connection diagram

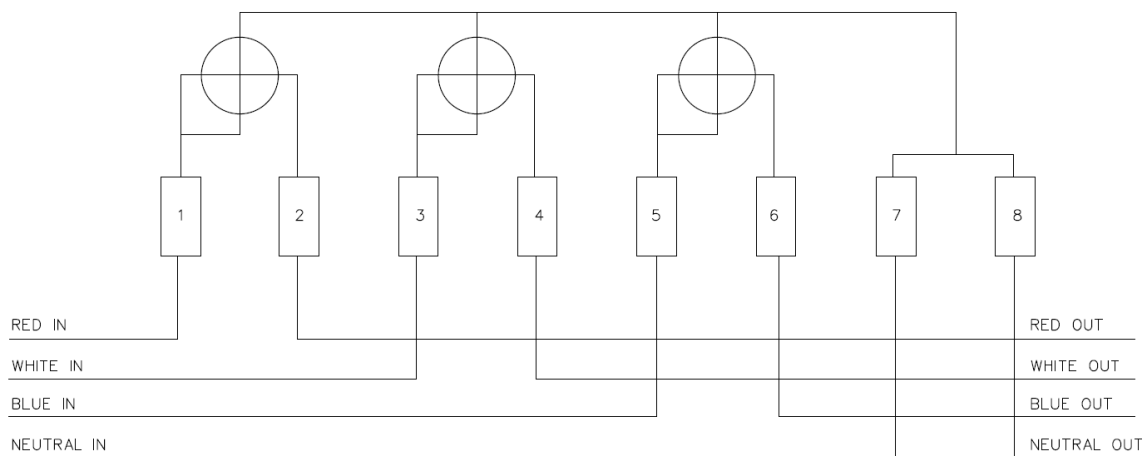

Figure 3 — Three phase whole current meter connection diagram

b) DIN rail as specified in Annex B. DIN rail single phase meters shall provide two neutral terminals.

NOTE The majority of meters are expected to be installed in the place of existing electromechanical credit meters and common base prepayment meters.

Fastening of the supply wiring shall either be by means of two securing screws on each terminal, or by means of a clamp terminal using one screw.

The securing screws and terminals shall be of non-ferrous metal.

Each electrical supply or load wiring terminal shall present an opening of at least 8 mm wide by 8 mm high or 8 mm in diameter.

5.2.4 Sealing

Provision shall be made for sealing meters in accordance with NRS 096-1. It shall be possible to seal the terminal cover and front cover separately (if the cover is removable).

5.2.5 Meter numbering

The meter serial number and barcode shall be in accordance with SANS 474 Annex A. The serial number as specified in IEC 62055 Part 41, shall be displayed as nameplate data and also be stored in the meter's non-volatile memory.

5.3 Climatic requirements

In the case of a multi-device installation, each device shall be tested separately for compliance against its own particular requirements, while maintaining connection between the devices.

5.4 Electrical requirements

The basic current I_b shall be 20 A or lower for all meters.

The maximum current rating for single-phase meters shall be at least 80 A.

The maximum current rating for three-phase meters shall be at least 100 A per phase.

The maximum current rating for three-phase CT driven meters shall be at least 5 A per phase.

The meter (single phase or three phase) shall operate correctly with a current input of at least 1,2 I_{max}

The utilization category for the supply control switch shall be UC2.

The supply control switch shall be a mechanically latching device and shall make and break all live circuits of the supply to the load. It shall not be required to be permanently energized in order to remain in the open or in the closed position.

The supply control switch shall be rated for a minimum of 80 A for single-phase meters and 100 A per phase for three-phase meters.

Printed circuits shall not be used to conduct current from instrumentation current transformers.

5.5 Metering accuracy requirements

The accuracy class for single-phase and three-phase active energy meters shall be at least class 1, in accordance with SANS 62053 Part 21.

The accuracy class for single-phase and three-phase reactive energy meters shall be at least class 2, in accordance with SANS 62053 Part 24.

The same accuracy classes shall be applicable to meters that operate in both credit mode and prepayment mode.

5.5.1 Calibration

All meters shall be calibrated at an accredited test facility (see SANS 474) before delivery, to ensure that the accuracy limits are within the requirements as specified in table 1 for active energy and, if applicable, table 2 for reactive energy.

Table 1 — Calibration test points for active energy

1	2	3	4	5	6
Load point	Current	Power factor	Applicable meter type	Load in case of three-phase meters	Maximum error limit %
1	0,05 I_b	1	Single and polyphase	Balanced	$\pm 1,5$
2	0,1 I_b	1	Single and polyphase	Balanced	± 1
3	I_b	0,5 lag	Single and polyphase	Balanced	± 1
4	I_b	1	Polyphase	Phase A ⁽²⁾	± 2
5	I_b	1	Polyphase	Phase B ⁽²⁾	± 2
6	I_b	1	Polyphase	Phase C ⁽²⁾	± 2
7	I_{max}	1	Single and polyphase	Balanced	± 1

² The voltage shall only be applied to phase tested

Table 2 — Calibration test points for reactive energy

1	2	3	4	5	6
Load point	Current	Power factor	Applicable meter type	Load in case of three-phase meters	Maximum error limit %
1	0,05 I_b	0	Single and polyphase	Balanced	$\pm 2,5$
2	I_b	0	Single and polyphase	Balanced	± 2
3	I_b	0,866 lag	Single and polyphase	Balanced	± 2
4	I_b	0	Polyphase	Phase A ⁽²⁾	± 3
5	I_b	0	Polyphase	Phase B ⁽²⁾	± 3
6	I_b	0	Polyphase	Phase C ⁽²⁾	± 3
7	I_{max}	0	Single and polyphase	Balanced	± 2

² The voltage shall only be applied to phase tested.

The reference conditions of IEC 62058 Part 31 apply.

A "TESTED" sticker as specified in SANS 474 shall be applied to the meter and shall comply with SANAS/IEC 17025.

The measuring process shall be such that the overall uncertainty of measurement does not exceed the values stated in IEC 62058 Part 31.

The calibration results shall be available to the purchaser in an electronic format as an import file compatible with Microsoft Windows ® software.

5.6 Time keeping requirements

Where a device keeps time by design it shall maintain an accuracy to within 20 parts per million under reference conditions.

Where a replaceable battery is used to maintain the time keeping function in the device, it shall be fitted under a separate sealable cover. By design it shall have a minimum shelf life of ten years and a minimum standby service life of three years in the absence of supply to the device.

The meter shall detect when the battery fails, in which case it shall revert to the following basic default functionality.

- fall-back to a default single rate tariff; and
- record the consumed kWh in a separate register until the battery is replaced.

The meter shall detect when the battery is restored, in which case it shall resume with its programmed tariff as it was prior to when the battery failed.

During any loss of supply, the time of the clock shall be maintained for at least 7 days.

5.7 Communication interfaces

The M interface is compulsory for all smart meters and shall be implemented as optical port specified in IEC 62056-21. Additionally, the smart meter shall either have C interface or G interface or both. For the C interface the smart meter shall have a PLC or RF modem. For the G interface the smart meter shall have a cellular modem. **The supported PLC, RF and cellular technology shall be specified in NRS 049-5-1. The communication protocol for all interfaces shall be implemented as specified in NRS 049-5-1.**

NOTE The interfaces (i.e. M, C and G) are shown Figure1.

5.8 Functional requirements

5.8.1 Tariff implementation

The configurable time definitions in a) to c) shall be provided by the meter.

- a) At least four different time periods within each day (peak, critical peak, standard and off-peak). It shall be possible to switch them in any possible combination. At least eight switching cycles shall be catered for per day.
- b) Two different weekend day switching schedules.
- c) High-demand and low-demand periods i.e., summer and winter rates.

In prepayment mode, credit will be added by means of a currency token. The fixed/network charge tariffs shall provide at least 4 fixed charges and 4 consumption charges.

The implementation of the TOU tariffs for prepayment mode shall be catered for in the meter. These factors shall be configurable through messages from the AMI HES.

5.8.2 Load profile (Mass memory)

All meters shall be capable of storing the specified interval data locally. i.e., within the meter's own memory.

NOTE AMI systems that use data concentrators, where data is stored in the concentrator. Although this is acceptable it does not detract from the minimum requirement for all meters to store their own data as specified.

Energy meters shall cater for at least six channels of load profile memory (forward and reverse active energy and Q1, Q2, Q3 and Q4 reactive energy) for a period of at least 100 days over a 30-minute integration period.

The integration period shall be configurable (typical intervals are 60, 30 and 15 minutes).

The following non-interval data shall be stored on the meter, and it shall be possible to retrieve this data through remote or local communication with the meter:

- a) total energy;
- b) total energy per time-of-use register;
- c) status alarms:
 - i) to verify the integrity of the data, and
 - ii) to flag a failed battery or low battery voltage.
- d) event recording: specifically; and
 - i) tamper detected,
 - ii) disconnect / reconnect,
 - iii) master station supply capacity control and appliance (load) control override, and

- iv) meter configuration change.
- e) quality of supply recording: specifically.
 - i) voltage harmonics,
 - ii) voltage swells,
 - iii) voltage sags,
 - iv) power outages,
 - v) frequency variations, and
 - vi) detection of unbalanced load by 3 phase meters.

Voltage limits shall be programmable from $\pm 5\%$ to $\pm 15\%$ of nominal voltage in steps of 1% and discriminator duration times shall be programmable from 1 to 3600 s.

Frequency limits shall be programmable from $\pm 0,5\%$ to $\pm 2\%$ of nominal frequency in steps of $0,1\%$.

Functionality shall be available for the automatic reporting of at least three of these events to the master station (configurable). The meter shall be capable of storing data equivalent to minimum of 1000 mandatory events.

All data and events (interval and non-interval) shall be date-stamped and time-stamped at the meter with a resolution of at least 1 min.

5.8.3 Manual meter reading

The meter shall support manual meter reading either through a display on the meter or through an external meter reading device.

5.8.4 Self registration of meters

Meters shall have the capability to self-register with the HES after being commissioned and to verify their status with the HES periodically thereafter.

5.9 Functional requirements for the meter's load control capability

5.9.1 Capability

The meter shall be capable of receiving and acting on commands for the disconnection or reconnection, capacity control and appliance control, according to user-configurable commands from the HES.

5.9.2 Customer disconnect and reconnect

The meter shall support both local and remote disconnection of the customer's primary load, and local and remote reconnection by means of the meter's load switch.

When a meter performs a disconnect operation, all outgoing live customer circuits shall be disconnected from the meter.

To confirm the current state of a meter, the AMI system shall support "on-demand" remote interrogation of the meter to determine whether the load switch is open or closed.

The meter shall provide clear local indication of the status (open/closed) of the load switch.

An event shall be logged within the meter's event register after a connect or a disconnect operation. The cause of the event shall also be logged.

Local disconnect of the load switch of the meter shall only be able to be performed by the utility. Unauthorized persons shall be physically prevented from operating the load switch to disconnect supply.

5.9.3 Supply capacity control (Load limiting)

Supply capacity control may be applied in cases where there is a constraint on the electricity supply, and it can be applied automatically during defined peak periods as determined by a switching schedule on the meter.

AMI meters shall have two supply capacity constraint limit settings – a restricted demand limit and an emergency limit (which will normally represent a lower limit than the restricted demand limit).

NOTE The maximum installation supply limit is determined by the external circuit breaker. The maximum current rating of the meter is not considered as a supply capacity constraint limit.

5.9.3.1 Restricted demand limit

The restricted demand supply capacity limit operation shall function as explained in a) to e).

- a) the load switch shall open if the average kW demand across the last A minutes is greater than the demand limit (B kW), where

A is settable from 1 min to 60 min in increments of one-minute intervals;

B is settable from 1 kW to 75 kW in increments of 0,5 kW (for three-phase meters);

B is settable from 1 kW to 16 kW in increments of 0,5 kW (for single-phase meters).

- b) enabling, disabling and event recording;

The supply capacity control functionality shall be able to be remotely and locally enabled and disabled.

If the load switch has opened due to the demand having exceeded the restricted demand limit, the switch shall remain open for a period of C minutes, where:

C is settable from 1 min to 60 min in increments of one minute; and then automatically reclose.

The contactor “open” period shall increment automatically by a settable time period after each subsequent operation. The meter shall revert back to the original C minutes open setting after the restricted demand limit command has been cancelled.

The disconnection and any subsequent reconnection shall be recorded as events.

- c) the AMI system shall have the capability to both remotely and locally activate or de-activate the restricted demand limit in AMI meters by either groups of meters, or by commands sent to individual meters;
- d) the meter shall make provision for five sets of restricted demand limit time periods per weekday and five sets of time periods per weekend day. This requirement allows for it to function automatically during certain time periods of the day (for example during peak tariff periods).
- e) restricted demand limit time periods shall be remotely and locally settable for each meter individually and in groups through commands received from the master station.

5.9.3.2 Emergency limit

The emergency limit operation shall function as explained in 5.9.3.1 a) to b), with the only difference the lower setting in kW demand.

- a) when activated, the emergency limit shall take precedence over all other supply capacity settings.
- b) the emergency limit shall be de-activated by commands from the master station and/or;
- c) the meter shall automatically fall back to its normal operating mode after a settable period of time has lapsed from receiving the emergency limit command. The duration of the time period shall be settable between 1 h to 24 h; and
- d) the emergency limit functionality in AMI meters shall be capable of being remotely and locally enabled or disabled for selected meters.

All supply capacity control settings shall be remotely and locally configurable.

6. Particular requirements for the bulk meter

6.1 General

Bulk meters shall meet the general requirements given in paragraph 3 and 4, except where these are modified in the following clauses:

- a) the bulk meter shall be able to interface to the NG/DC or to the HES; and
- b) the bulk meter is not required to interface to a CIU.

Section 5.9 is not applicable.

6.1.1 Terminal arrangement for meter

The requirements for whole current meters shall be as specified in paragraph 5.2.3.

The terminal arrangements for CT driven meters shall be as specified in figure 4.

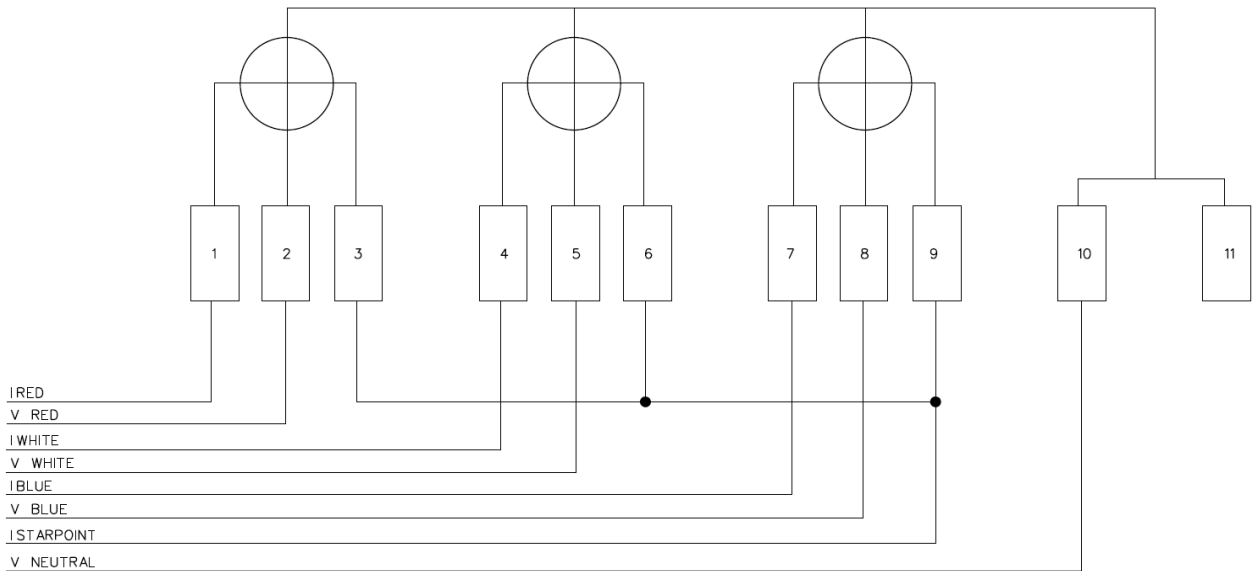

Figure 4 — Three phase CT driven meter connection diagram

7. Particular requirements for customer interface units

7.1 General

The CIU is intended to be used in a multi-device installation and shall be tested together with the other devices as a whole (see also 4).

CIU serial number shall be engraved in non-conspicuous manner. Space shall also be available to fix a label/write serial number of the meter connected to the CIU for customer reference purposes.

7.2 Construction requirements

7.2.1 Protection against the ingress of dust and water

The CIU is intended for installation in enclosures located inside buildings. It shall be rated as IP52 for protection against penetration of dust and water.

7.2.2 Mounting options

The CIU shall offer at least one of the following mounting options:

- a) part of the electrical installation – the requirements of SANS 10142 Part 11 shall be adhered to;
- b) surface mountable; and

i) Able to be plugged directly into a standard mains socket-outlet with a minimum cord length of 1 meter, and

NOTE When a device offers three-pin mains plug mounting option, the 16A plug and the 16A socket on the device shall comply with SANS 164-1.

ii) Free standing upright on its own.

- c) able to be plugged directly into a common base as specified in SANS 1524-1-1.

The requirements for mounting of the CIU shall be stated in the purchase agreement.

7.3 Electrical requirements

The CIU shall remain functional after the meter has disconnected the electricity supply to the premises.

Where a CIU employs a battery, the instructions concerning the replacement of the battery shall preferably be displayed on the device body. No special tools shall be required to replace the battery.

The battery utilised in the CIU shall either be PM9, AA or AAA types.

The battery compartment shall be designed to prevent damage from electrolyte leakage.

7.4 Display

The display shall be able to display scrolling messages of at least 160 characters long. Characters may comprise alphanumeric characters, symbols, and icons. If symbols or icons are used, their meaning shall be explained in a user manual provided with each CIU. The characters of the display shall be at least 4 mm in height.

Buttons or other means shall be provided to allow for navigation of all information as specified in the purchase agreement.

The CIU display shall be capable of being read in the dark. This capability shall be activated by pressing any button on the keypad.

The CIU display shall have anti-glare and non-blinking properties. Filters shall have a non-reflective finish and be suitable for use in direct sunlight.

It shall be possible to display the contents of all relevant registers or parts of such registers in a utility-defined sequence.

The energy values to be displayed shall consist of at least six significant digits. The normal display need not indicate any fractions of kWh. Provision shall be made for a resolution of at least 1/10 kWh for testing and calibration purposes.

7.5 User manual

A user manual shall be provided with each CIU.

The user manual shall as a minimum contain the following:

- a) instructions for the operation of the CIU;
- b) instructions for entering meter tokens;
- c) if symbols or icons are used, their meaning shall be explained in the user manual; and
- d) where a CIU employs a battery, the instructions concerning the replacement of the battery shall be detailed in the user manual.

7.6 Functional requirements for the displays (Meter and customer interface unit)

7.6.1 General

Meters and the associated CIU shall only receive and display information pertaining to the electricity supply to the relevant customer’s premises.

7.6.2 Displayed information

Table 6 specifies the information that shall be capable of being displayed on the various displays for active / reactive energy meters that operate in credit mode.

NOTE 1 The information is obtained direct from the meter, notwithstanding that where concentrators are used, the data might be duplicated in the concentrator.

NOTE 2 Where the meter has no display then the values as listed below for the CIU shall be applicable.

Table 6 – Displayed information for active energy meters operating in credit mode

1	2	3
Display information	Meter display	Customer interface unit display
Meter identification number (serial number)	Yes	Yes
Date and time	Yes	Yes
TOU rate 1 kWh (import)	Yes	Yes
TOU rate 2 kWh (import)	Yes	Yes
TOU rate 3 kWh (import)	Yes	Yes
Total kWh (import)	Yes	Yes

1	2	3
Display information	Meter display	Customer interface unit display
Total kvarh (import)	Yes	Yes
TOU rate 1 kWh (export)	Yes	Yes
TOU rate 2 kWh (export)	Yes	Yes
TOU rate 3 kWh (export)	Yes	Yes
Total kWh (export)	Yes	Yes
Total kvarh (export)	Yes	Yes
Energy cost (current billing month) (Rand value)	No	Yes
Energy cost (previous interval) (Rand value)	No	Yes
Water (auxiliary) meter reading (If option is required – see Annex A section G)	Optional	Optional
Demand (kW) ^(a)	Engineering ^(b)	Yes
Status of appliance switching (open / closed)	Engineering	Yes
Supply capacity limit (kW)	Engineering	Yes
Meter event: Disconnect	Engineering	Yes
Appliance switching times	Engineering	Engineering
Meter event: Tamper detected	Engineering	Engineering
Meter event: Over-and undervoltage	Engineering	Engineering
Meter event: Emergency appliance control	Engineering	Engineering
Meter event: Meter configuration change	Engineering	Engineering
Maximum demand kVA import (current month)	Yes	Yes
Maximum demand kW import (current month)	Yes	Yes
Maximum demand kVA import (previous month)	Yes	Yes
Maximum demand kW import (previous month)	Yes	Yes
Maximum demand kVA export (current month)	Yes	Yes
Maximum demand kW export (current month)	Yes	Yes
Maximum demand kVA export (previous month)	Yes	Yes
Maximum demand kW export (previous month)	Yes	Yes
<p>a) Demand is a resettable display, that shall be capable of displaying</p> <ol style="list-style-type: none"> 1) maximum demand for a current billing period, 2) maximum demand for a previous billing period, and 3) instantaneous demand. <p>b) Engineering values need not be displayed in the normal display sequence; they can be displayed through a separate display sequence.</p>		

When the meter is in prepayment mode, the requirements of clause 5.4.2 in IEC 62055 Part 31 shall apply. In addition, the smart meter shall display, by default, the minimum data and measurement item specified in Table 6 above and Table 7 below, on its integrated indicating display and customer interface unit.

Table 7– Displayed information for meters that operate in prepayment mode

1	2	3
Display information	Meter display	Customer interface unit display
Tariff index	Yes	Yes

1	2	3
Display information	Meter display	Customer interface unit display
Available credit	Yes	Yes
Last purchase transaction (time, data, and amount)	Yes	Yes
Price per kWh (Import)	Yes	Yes
Price per kWh (Export)	Yes	Yes
Standing charge	Yes	Yes
Price per kWh rate 1	Yes	Yes
Price per kWh rate 2	Yes	Yes
Price per kWh rate 3	Yes	Yes
Price per kvarh rate 1	Yes	Yes
Price per kvarh rate 2	Yes	Yes
Price per kvarh rate 3	Yes	Yes
Key revision number	Engineering ^(a)	Engineering
Key type	Engineering	Engineering
Token ID of latest credit token	Engineering	Engineering
Software version	Engineering	Engineering
Supply capacity limit (kW)	Engineering	Engineering
^{a)} Engineering values need not be displayed in the normal display sequence; they can be displayed through a separate display sequence.		

8. Particular requirements for the network gateway/data concentrator

8.1 General

NG/DCs shall meet the general requirements given in clause 5, except where these are modified in the following clauses.

The NG/DC shall have the capacity to connect to at least 50 meters.

8.2 Construction requirements

8.2.1 Protection against the ingress of dust and water

The NG/DG is intended for installation in enclosures located outside buildings. It shall be rated as IP51 for protection against penetration of dust and water.

The NG/DC shall be available in housings that are suitable for one of the following mounting methods:

- a) surface mounting; and
- b) DIN-rail mounting.

The requirements for mounting of the NG/DC shall be stated in the purchase agreement.

8.3 Electrical requirements

The requirements given in section 5.5 shall apply, except that the voltage range shall be as given in Table 3.

The power consumption shall be less than 15W/30VA.

The requirements and tests given in 5.5 shall apply.

8.4 Time keeping requirements

Where a device keeps time by design it shall maintain an accuracy to within 20 parts per million under reference conditions.

Where a replaceable battery is used to maintain the time keeping function in the device, it shall be fitted under a separate cover. By design it shall have a minimum shelf life of ten years and a minimum standby service life of three years in the absence of supply to the device.

During any loss of supply, the time of the clock shall be maintained for at least 7 days.

8.5 Communication interfaces

The NG/DCs shall have an optical port for data reading and configuration that will conform to SANS 62056 Part 21.

The NG/DCs shall have a serial port (such as RS 232 or RS 485 (preferably an RJ12 or RJ45 connection)) that will be used for communication to a remote system for a stand-alone application.

The NG/DCs shall have a PLC or RF communication interface that will be used for communication to remote meters.

9. Particular requirements for modems

9.1 General

Cellular Network Modems are required for communication between the HES and network gateway as well as stand-alone metering installations (G Interface). Both modular on-board modems and external modems are acceptable.

9.2 Mechanical requirements

For external modems the following requirements shall apply:

The modem enclosure shall be manufactured of a durable high-impact flame-retardant plastic or metal extrusion or moulding.

The modem casing must have a minimum ingress protection rating of IP51 for protection against dust and water.

The dimensions of the modem shall not exceed 180 mm high by 110 mm wide by 80 mm deep.

External modems shall be DIN-rail mountable or have a suitable mounting solution which will allow it to be securely mounted onto a flat surface.

For on-board modems the following requirements shall apply:

- a) the on-board modems shall be modular such that the modem can be replaced without having to replace the meter/data concentrator/Network gateway; and
- b) the insertion and removal of the modular on-board modem shall be such that it does not interfere with the wiring and or live operations of the data concentrator/network gateway and meter.

9.3 Transceiver

9.3.1 GSM module

The GSM module shall be CE approved and shall comply with the following approved standards:

- a) 3GPP TS 51.010-1 – Mobile station conformance specification;
- b) ETSI EN 301 511 – Harmonized standard for MS in the 900 and 1 800 GSM bands;
- c) GCF-CC – Global Certification Forum – Certification Criteria;
- d) ET ETSI EN 301 489-1 and 7 – Electromagnetic compatibility for radio equipment and services; and
- e) SANS 60950-1 - Information technology equipment safety.

9.3.2 Modems

The following requirements shall apply to the modems:

- a) type approved by the Independent Communications Authority of South Africa (ICASA) for use in South Africa as well as network approved by all South African network service providers;
- b) as a minimum, 3G capable with a fall-back option to GPRS;
- c) at least support GPRS multi-class 10;
- d) GPRS Class B device;
- e) as a minimum, is dual band for use in the 900 MHz and 1 800 MHz frequency bands; and
- f) preferably Hayes compatible.

9.4 Network communications

The modem shall act as a server and expose a pre-configured IP port on its WAN link that transparently connects the HES to the meter/data concentrator/network gateway.

The modem shall also be able to act as a client to enable connections initiated from an IED connected to the modem.

The modem shall support the Transmission Control Protocol/Internet Protocol suite (TCP/IP).

The modem shall support both even and non-parity types for serial communications.

The modem shall support hardware and software flow control.

9.5 Network settings

The modem shall be able to be configured with the following minimum set of parameters to enable it to automatically connect to a private Access Point Name (APN):

- a) the name of the APN;
- b) a username and password; and
- c) a default allocated port number for access via the HES system.

NOTE This port number shall be user-configurable.

The modem shall offer the following minimum set of parameters for client mode:

- d) destination IP address; and
- e) destination port number.

9.6 Identity modules

Both Chip SIM modems as well as modems that make use of a removable SIM card are acceptable.

For Chip SIM modems, preference shall be given to devices that allow for more than one service provider in order to avoid the devices being network-locked to a single network.

It is preferred that modems with a removable SIM have an externally accessible push-push mini-SIM card slot.

Dual SIM capable modems shall be able to automatically select a service provider network when in client mode and when in server mode, the switching shall be selectable both locally and remotely.

The modem shall offer a mechanism to ensure that the standby SIM for dual SIM modems is not deactivated by the network due to inactivity. The supplier shall state how this is achieved.

The modem shall offer a mechanism to avoid network flapping whereby the modem jumps between networks. The supplier shall state how this is achieved.

The SIM card slot (s) of removable SIM modems shall be easily accessible and located such that the SIM(s) can be easily replaced.

9.7 Modem indications

All physical status indications shall be clearly visible on the front of the cellular modem. A combination of indicators can be used for any of the indications provided, but it shall also be unambiguous and easily identifiable. Light-emitting Diode (LED) indication is preferred.

The following status indications are a minimum requirement:

- a) indication of the various cellular network mode statuses; example distinguishing between PSD & CSD as well as distinguishing between the various PSD technologies viz. GPRS, EDGE, 3G and LTE;
- b) indication of when cellular communication is established;
- c) data transmit indication; and
- d) data receive indication.

9.8 Diagnostics

The modem shall have a hardware and software watchdog timer. These timers shall perform their own internal diagnostics that shall operate independently from each other and at least perform or offer the following:

- a) a cold restart if no communication has taken place in a 36-h period;
- b) a cold restart if the modem loses cellular network authentication for more than 10 min; and
- c) the cold restart functionality if remotely activated, for example through an SMS.

The Radio Frequency (RF) output circuitry shall be protected against inadvertent open or short circuiting of the antenna or coaxial cable and shall be of the self-restoring type.

The modem shall be able to remotely and through communicating via a computer or tool provide its received cellular network signal strength indication.

It is preferred that the modem be capable of reporting its serial number and firmware version both remotely and through communicating via a computer or tool. The supplier shall specify how this information is provided.

Modems shall offer Telnet as an IP configuration service as a minimum. Preference shall be given to modems that offer an embedded web server for configuration and remote management.

It shall also be possible to remotely configure modems through SMS, terminal or any other software that will be provided by the modem supplier free of charge.

The supplier shall provide details of any additional diagnostics features.

9.9 Modem security

The modem shall preferably support the authentication and encryption of the network link using Secure Socket Layer (SSL) or equivalent.

The modem shall preferably support access control lists to only allow for connections to and from selected users (MSISDN's and IP's).

The supplier shall state which other security features are supported and how it is implemented.

9.10 Power supply

For external modems the following requirements shall apply:

The modem shall have a power supply which shall be able to operate from 110 V ac and from a 230 V ac supply.

Internal power supplies are preferred, but where an external power supply is offered, it shall be DIN rail mountable.

It is preferred that modems offer some type of power-down delay through a super-cap or similar, to enable alarm reporting under a power failure.

The power supply shall at least comply with the following specifications:

- a) SANS 60950-1 - Information technology equipment standard;
- b) EN 55022 – Information technology equipment: Radio disturbance characteristics; and
- c) SANS 61000-4-5 – Electromagnetic compatibility (EMC) Part 4-5: Testing and measurements techniques – Surge immunity test.

For on-board modems the following requirements shall apply:

- d) the modem shall be internally powered from the meter or network gateway power supply; and
- e) it is preferred that the modem, either through the power supply of the meter or network gateway, offers some type of power-down delay through a super-cap or similar, to enable alarm reporting under a power failure.

9.11 External connectors

The RF connector shall be of SMA type (female) and be easily accessible.

The RF connector shall have a non-reactive impedance of 50 Ω .

For external modems the following requirements shall apply:

- a) the modem shall have an RS485 and additional RS232 serial communication data port, preferably through an RJ12 or RJ45 connector. Preference shall also be given to modems that offer an Ethernet (IP) communication port;
- b) modems shall offer a diagnostic port which could be a shared port with the RS232 or Ethernet data port; and
- c) the communication speed of the serial link shall be selectable from 2 400 bd to a maximum of at least 57 600 bd.

For on-board modems the following requirements shall apply:

- d) the modem shall be configurable through the meter's or the network gateway's configuration port. Where this is not possible, the modem shall offer a configuration/diagnostic port that shall either be RS232 via an RJ12 or RJ45 connector or Ethernet; and

- e) the meter and network gateway shall offer a data communication port for future connectivity of an external modem. It is preferred that this data communication port will be a serial port (RS232/RS485) for meters and an Ethernet port for the network gateway.

The communication speed of the serial links shall be selectable as a minimum between 2 400 bd to a maximum of at least 57 600 bd.

Annex A – Use cases for smart meters

(informative)

A.1 General

The following functional use-cases, seen as business capabilities, are intended to describe the functions performed by the summation of a number of technical capabilities. This level of description intends to demonstrate how a number of business benefits can be realized by means of utilizing a collection of technical capabilities.

All use case parameters are configurable at production stage or during operation.

The meter, NG/DC shall ensure that remotely issued HES commands always take priority over locally issued HHU commands.

The metering system shall support the following use cases, in turn supported by the meter COSEM interface objects defined in part 5 of NRS 049.

A.2 Meter events

A.2.1 RecordMeterEvent

The meter shall maintain an event logging register with a capacity of at least 1000 events. Note: first in first out.

Each event shall be recorded in the meter together with a date and time stamp and the cause of the event.

A.2.2 ReportMeterEvent

The meter shall issue a push notification to the HES for each event if such event has been enabled to do so. Each notification shall include a date and time stamp and the cause of the event.

It shall be possible for the meter to receive, accept and process commands issued by the HES to selectively enable or disable push notifications on the meter to the HES per event type. The specific event types are as given in the various use cases.

A.3 Account

A.3.1 OperateInPrepaymentMode

The customer first makes a payment into his account, which then causes the supply to his/her premises to be connected for the duration that the account remains in credit. Once the customer has consumed his/her available credit, this causes the supply to his/her premises to be disconnected.

A.3.2 OperationInPostPaymentMode

The meter account is set to post-payment mode and plays no further part in the meter accounting process. The active customer account is then generally located in the ERPS.

The supply to the customer's premises is connected first, then he consumes the service, meter readings are sent to the ERPS, and a bill is sent to the customer. If the customer pays his bill, the supply remains connected, else the supply is disconnected. This is not automated.

A.3.3 ConfigureAccountRemote

The account parameters are programmed into the meter from the ERPS. The meter should be able to accept and process account parameters from the ERPS.

Annex A

(continued)

A.3.4 ConfigureAccountLocal

The account parameters are programmed into the meter from the ERPS via the HHU. The meter should be able to accept and process account parameters from the ERPS via the HHU.

A.3.5 ChangeAccountingModeLocal

The relevant parameter that controls the accounting mode is programmed into the meter from the ERPS. The meter should be able to accept and process account parameters from the ERPS.

A.3.6 ChangeAccountingModeLocal

The relevant parameter that controls the accounting mode is programmed into the meter from the ERPS via the HHU. The meter should be able to accept and process account parameters from the ERPS via the HHU.

A.4 Charges

A.4.1 General

TOU and block tariffs shall provide at least 8-time intervals, 4 consumption blocks and 32 time/block intervals per day.

The fixed/network charge tariffs shall provide at least 4 fixed charges and 4 consumption charges.

All tariffs shall provide for two seasonal programs, for example, summer and winter.

Different profiles shall be programmable for weekdays, week-end days and seasonal periods.

A.4.2 ConfigTariffRemote

The tariff rates are programmed remotely into the meter from the ERPS. The meter should be able to accept and process tariff rates.

A.4.3 ConfigTariffLocal

The tariff rates are programmed locally into the meter from the ERPS via the HHU. The meter should be able to accept and process tariff rates.

A.4.4 ChargeFlatTariffRateLocal

Customer active energy consumption is charged against the meter account in accordance with a programmable single rate tariff applied in the meter.

The cumulative active energy consumed during the billing period is recorded in the meter register for later upload to the HES.

A.4.5 ChargeBlockTariffRateLocal

Customer energy consumption is charged against the meter account in accordance with a programmable block tariff rate applied in the meter.

The cumulative energy consumed during the billing period is recorded in the meter for later upload to the HES. The register segments the recorded consumption into sub-values according to each consumption block.

Annex A

(continued)

A.4.6 ChargeTimeOfUseTariffRateLocal

Customer energy consumption is charged against the meter account in accordance with a programmable time of use tariff rate applied in the meter.

The cumulative active energy consumed during the billing interval is recorded in the meter for later upload to the HES. The register segments the recorded consumption into sub-values according to each time interval.

A.4.7 ChargeMaximumDemandRateLocal

Customer demand is charged against the meter account in accordance with a programmable demand tariff rate applied in the meter. The registered electricity demand for the billing interval is recorded in the meter for later upload to the HES.

A.4.8 ChargeFixedRateLocal

Customer fixed/network charge is charged against the meter account in accordance with a programmable fixed charge tariff rate applied in the meter. The cumulative fixed/network charges during the billing interval are recorded in the meter for later upload to the HES.

A.5 Credit

A.5.1 EnterTokenCreditLocal

A customer payment received at the POS is converted into a currency credit token and delivered to the customer for entry into the meter. Interactive customer feedback is via the CIU display.

A.5.2 EnterTokenCreditRemote

A customer payment received at the POS is converted into a currency credit token and entered into the meter via an online connection. Interactive customer feedback is via the CIU display.

A.5.3 CreditExportEnergyLocal

Customer active energy exported to the network is credited to the meter account in accordance with a programmable single rate tariff applied in the meter.

The cumulative energy generated during the billing period is recorded in the meter register for later upload to the HES.

A.6 Metering

A.6.1 RecordMeteringParameters

The meter continuously measures and records various metering parameters and stores their values in a suitable set of local registers for a predetermined period of time.

Load profile records shall be maintained in the meter providing for a minimum of 4800 record entries. Integration periods shall be programmable, and the default values shall be 15, 20, 30 and 60 minutes.

Annex A

(continued)

A.6.2 PushMeterParametersOnScheduleRemote

The meter shall support the following use case variants:

- a) The meter periodically pushes the measured and stored metering parameter values to the HES according to a predefined schedule located in the meter. The data to be pushed is a pre-selected set determined by the HES; and
- b) The meter periodically pushes the measured and stored metering parameter values to the HES according to a random schedule located in the meter. The data to be pushed is a pre-selected set determined by the HES.

As a minimum, three-meter readings per day shall be supported.

A.6.3 ReadMeterOnDemandRemote (HES)

The meter shall receive, accept, and process the command from the HES to read the measured and stored metering parameter values on demand.

This use case shall be supported by two use case variants:

- a) the meter accepts and process a command from the HES to read a complete set of the meter reading data; and
- b) the meter accepts and process a command from the HES to read a sub-set of the meter reading data.

The meter may also accept and process a read request from the HES that was initiated by the ERPS.

A.6.4 ReadMeterOnDemandLocal

The meter shall receive, accept, and process the command from the HHU or CIU to read the measured and stored metering parameter values on demand.

A.7 Auxiliary metering

A.7.1 RecordAuxiliaryMeteringParametersLocal

The auxiliary meter periodically pushes its measured metering parameter values to the meter acting as proxy, where the readings are temporarily stored in buffer registers for later upload to the HES.

The auxiliary meter is usually battery powered and thus it may constrain the communications cycle in order to conserve battery life.

A.7.2 ReadAuxiliaryMeterOnDemandRemote

This use case is identical A.6.3 except that the buffer registers relating to the auxiliary meter are read.

A.7.3 ReadAuxiliaryMeterOnDemandLocal

This use case is identical to A.6.4 except that the buffer registers relating to the auxiliary meter are read.

Annex A

(continued)

A.8 Bulk metering

A.8.1 General

A bulk meter is simply another instance of meter having exactly the same functional properties, except that it does not have accounting and disconnect functions.

A.8.2 RecordBulkMeteringParametersLocal

This use case is identical to A.6.1.

A.8.3 ReadBulkMeterOnDemandRemote

This use case is identical to A.6.3.

A.8.4 ReadBulkMeterOnDemandLocal

This use case is identical to A.6.4 except that the CIU is not able to read from the BulkMeter.

A.9 Load control

A.9.1 General

In order to spread the transition surge during group disconnect and reconnect actions a programmable random delay from 0 to 120 seconds in steps of 1 second shall be programmed into the load control algorithm.

It shall be possible for the meter to accept and process a command from the ERPS or HES to remotely program and operate the load control functions per single Meter or per group of meters. Remote interrogation of the load control functions shall be performed per single meter by the HES.

The STS SetPowerLimit token as defined in IEC 62055 Part 41 shall be implemented as the default power limit control function, onto which the meter will fall back when load limiting is not activated.

Each disconnect and reconnect operation shall be treated as an event.

Use cases for demand reduction shall apply to import and export energy. Import and export demand reduction control shall be separately programmable and shall function independently from each other.

Each phase of the supply shall be separately programmable from the other phases, but all phases shall disconnect or reconnect together.

An appropriate message is sent to the CIU and the mobile phone for each disconnect and reconnect event, indicating the cause of the event. A power bar shall also be displayed, indicating the active power limit setting and the actual power as measured by the meter.

A.9.2 ConfigLoadControlRemote

The meter shall accept and process the load control parameters programmed into the meter from the ERPS or HES.

A.9.3 ConfigLoadControlLocal

The meter shall accept and process the load control parameters programmed into the meter from the ERPS via the HHU.

Annex A

(continued)

A.9.4 ReadLoadControlStatusRemote

The meter shall accept and process a request from ERPS or HES to read the load control parameters and the status of the load switch of the meter.

A.9.5 ReadLoadControlStatusLocal

The meter shall accept and process a request from HHU or CIU to read the load control parameters and the status of the load switch of the meter.

A.9.6 DisconnectSupplyRemote

The meter shall accept and process the command from the EPRS or HES to remotely disconnect the supply to the customer's premises. The event is displayed on the CIU.

A.9.7 ReconnectSupplyRemote

The meter shall accept and process the command from the EPRS or HES to remotely reconnect the supply to the customer's premises. The event is displayed on the CIU.

A.9.8 DisconnectSupplyLocal

The supply to the customer's premises is disconnected by the HHU, CIU or mobile phone.

The event is displayed on the CIU or the mobile phone if there is sufficient power reserve available.

A.9.9 ReconnectSupplyLocal

The supply to the customer's premises is reconnected by the HHU, CIU or from the mobile phone.

The event is displayed on the CIU or the mobile phone.

A.9.10 ReduceDemandByCriticalPeakPriceControl

The metering system is able to credit the customer in an appropriate fashion when the customer successfully adheres to a demand reduction instruction given by the utility.

A.9.11 ReduceDemandByPowerLimitRemoteControl

There shall be a programmable restricted demand limit and a programmable emergency demand limit, which will normally be set below the restricted limit.

The restricted and emergency demand limit control functions shall be activated and deactivated by the ERPS or HES and sent to the meter via the AMI network.

The control algorithm shall operate in the following steps:

- a) the CIU shall warn the customer 60 minutes ahead of time that the demand limit is about to be activated;
- b) it shall sound an audible alarm and display the current demand value, the new limit value that will be activated and the duration for which the new limit will be applied;
- c) an audible alarm on the CIU and the mobile phone shall also warn the customer if the demand limit is about to be exceeded and shall automatically cancel when the demand falls below the warning threshold. The warning threshold shall be programmable from 5 % to 20 % in increments of 5 % below the active demand limit;
- d) the customer is able to pro-actively reduce his current demand to below the required new limit by switching off some of his appliances by means of manually switching off running appliances;

Annex A

(continued)

- e) during the time that the demand limit is active, the load switch shall open if the average kW demand during the last *A* minutes is greater than the active demand limit *B* kW, where:
 - i) *A* is programmable from 1 to 60 minutes in steps of 1 minute; and
 - ii) *B* is programmable from 1 to 75 kW in steps of 0,5 kW for a three-phase meter and from 1 to 16 kW in steps of 0,5 kW for a single-phase meter.
- f) the load switch shall remain open for a period of *C* minutes, where *C* is programmable from 1 to 60 minutes in increments of 1 minute, after which it shall automatically reclose.

If the demand still exceeds the active demand limit, the value of *C* shall increment by a programmable amount and then recursively repeat until the demand reduces to below the active demand limit, or until the demand limit function is deactivated by the ERPS or the HES.

The emergency demand limit control function shall operate the same as for restricted demand limit control, except that it shall take priority over any other active load control function.

The emergency demand limit shall remain active for a duration of *D* hours, programmable from 1 to 24 h in steps of 1 h, after which the Meter shall resume its previous operational state.

A.9.12 ReduceDemandByPowerLimitSchedule

The meter restricts the demand limit in accordance with a programmable schedule.

The demand limit schedule shall be activated and deactivated by the ERPS or the HES.

Provision shall be made for five time intervals per day from Monday to Friday and 5 time intervals per day from Saturday to Sunday. During these time intervals the load control shall operate automatically in accordance with the programmed schedule.

The control algorithm shall operate in the following steps:

- a) the CIU shall warn the customer 60 minutes ahead of time that the demand limit is about to be activated;
- b) it shall sound an audible alarm and display the current demand value, the new limit value that will be activated and the duration for which the new limit will be applied;
- c) an audible alarm on the CIU shall also warn the customer if the demand limit is about to be exceeded and shall automatically cancel when the demand falls below the warning threshold;

NOTE The warning threshold shall be programmable from 5 % to 20 % in increments of 5 % below the active demand limit;

- d) the customer is able to pro-actively reduce his current demand to below the warning threshold by switching off some of his appliances by means of manually switching off running appliances;
- e) during the time that the demand limit is active, the load switch shall open if the average kW demand during the last *A* minutes is greater than the active demand limit *B* kW, where:
 - i) *A* is programmable from 1 to 60 minutes in steps of 1 minute, and
 - ii) *B* is programmable from 1 to 75 kW in steps of 0,5 kW for a three-phase meter and from 1 to 16 kW in steps of 0,5 kW for a single-phase meter.
- f) the load switch shall remain open for a period of *C* minutes, where *C* is programmable from 1 to 60 minutes in increments of 1 minute, after which it shall automatically reclose; and

Annex A

(continued)

- g) if the demand still exceeds the active demand limit, the value of C shall increment by a programmable amount and then recursively repeat the process until the demand reduces to below the active demand limit, or until the demand limit schedule automatically terminates, or until the demand limit function is deactivated by the ERPS or HES.

A.9.13 DisconnectSupplyOnUnderFrequency

The supply to the customer's premises is disconnected when the supply frequency drops below a programmable limit and is automatically reconnected when the frequency returns to the normal level within the limits.

The control parameters are pre-programmed by the ERPS, HES or the HHU and thereafter sent to the meter for acceptance and processing.

Frequency limits shall be programmable from 48 to 50 Hz in steps of 0,1 Hz.

A programmable delay in disconnection time shall be from 100 to 5000 ms in steps of 100 ms. This delay shall override the random variable delay.

A programmable delay in reconnection time shall be from 100 to 5000 ms in steps of 100 ms. This delay shall override the random variable delay.

A subsequent low frequency detection event that occurs during the reconnection delay period shall retrigger the disconnect process immediately.

The event is displayed on the CIU.

A.10 Power quality

A.10.1 MonitorPowerQualityLocal

The meter monitors and records supply parameter values of the following events in a relevant set of logging registers.

NOTE These measurements are not equivalent to the quality of supply measurements as specified in NRS 048 and are not intended for contractual use.

Each log entry shall record the start time and the end time of the event, the phase effected, the maximum reached above the positive limit setting and the minimum reached below the negative limit setting.

voltage harmonics;
voltage swells;
voltage sags;
power outages.
frequency variations; and
detection of unbalanced load by 3 phase meters.

Voltage limits shall be programmable from $\pm 5\%$ to $\pm 15\%$ of nominal voltage in steps of 1 % and discriminator duration times shall be programmable from 1 to 3600 s.

Frequency limits shall be programmable from $\pm 0,5\%$ to $\pm 2\%$ of nominal frequency in steps of 0,1 %.

Annex A

(continued)

A.10.2 ReportPowerOutage

When a power outage event occurs as defined in 0, the NG/DC pushes a notification to the ERPS or HES, which shall take highest priority over any other process taking place in the NG/DC at that time.

By default, the NG/DC shall report power outages instead of the meter.

In the special case where the NG/DC is not present, the meter shall report power outages as described above.

A.10.3 ReadPowerQualityRecordsRemote HES

The stored power quality values defined in 5.8.2 are read from the meter on demand by the ERPS or HES.

A.10.4 ReadPowerQualityRecordsLocal

The stored power quality values defined in 5.8.2 are read from the meter on demand by the HHU.

A.11 Meter health monitoring

A.11.1 General

By default, no tamper events shall be displayed to the customer on the CIU.

A.11.2 MonitorBatteryCondition

The Meter monitors the condition of the internal battery and records the event in an alarm register when the battery voltage falls below a critically low value, thus indicating an imminent failure of the battery.

The internal meter battery alarm threshold shall be programmable by the ERPS, HES or HHU and by default it shall be pre-set by the Meter manufacturer to the recommended value according to the particular battery type and loading characteristics that will allow at least 1 month of battery life remaining.

A.11.3 MonitorTamperLocal

The Meter monitors and records events related to meter tampering in an alarm register.

The supply to the relevant customer premises is optionally disconnected as soon as the tamper event has been recorded in the meter. This option shall be programmable and selectable from the ERPS, HES or HHU. By default, it shall be disabled.

At least the following tamper events shall be monitored:

- a) breach of the sealed meter enclosure;
- b) phase reversal of the incoming supply; and
- c) bypass connection between the input and output terminals.

Some methods for detecting a bypass condition may conflict with the normal operation of the meter that is metering both import and export energy. In such a case the ERPS, HES or HHU shall be able to send a command to the meter to enable or disable this feature by programmable control.

A.11.4 ReportAlarmRemote

The meter automatically notifies the ERPS or HES when an event is recorded in the alarm register and pushes a notification together with the alarm register content to the HES.

Annex A

(continued)

A.11.5 ClearAlarmRemote

The meter shall be able to accept and process a command from the ERPS or HES to clear the alarm register in the Meter.

In the case where the alarm condition had caused the disconnection of the supply to the customer's premises, the reconnection shall occur automatically as soon as the alarm register has been cleared.

A.11.6 ReportAlarmLocal

The meter shall be able to accept and process a request from the HHU to read the alarm register in the Meter.

If the HHU detects an alarm condition according to the interpretation of the alarm register content, an appropriate message is displayed to the HHU operator who is then able to take appropriate action.

A.11.7 ClearAlarmLocal

In the case where the alarm condition had caused the disconnection of the supply to the customer's premises, the reconnection shall occur automatically as soon as the alarm register has been cleared.

An STS ClearTamper token may also be entered into the meter to clear the alarm register.

A.12 Customer information

A.12.1 DisplayLocalInformationOnCIU

If the particular function is implemented, the customer is able to selectively view the following local information on demand:

- a) available credit;
- b) low credit warning;
- c) last credit token received and accepted;
- d) token id (TID) of last credit token accepted;
- e) STS decoder reference number (DRN);
- f) STS tariff index (TI);
- g) STS key revision number (KRN);
- h) STS key type (KT);
- i) STS supply group code (SGC);
- j) consumption rate import;
- k) consumption rate export;
- l) import cumulative total kWh;
- m) export cumulative kWh;
- n) kvarh in quadrant 1;
- o) kvarh in quadrant 2;
- p) kvarh in quadrant 3;
- q) kvarh in quadrant 4;
- r) instantaneous demand active kWh;
- s) active tariff rate;
- t) historical active energy per tariff interval;
- u) historical peak power per tariff interval;
- v) interval energy consumption;
- w) energy cost for current billing period;
- x) energy cost for previous billing period;
- y) billing registers for manual meter reading;

Annex A

(continued)

- z) maximum demand for current billing period;
- aa) maximum demand for previous billing period;
- bb) status of the incoming supply L1;
- cc) status of the incoming supply L2;
- dd) status of the incoming supply L3;
- ee) state of the load switch (open/closed);
- ff) power limit settings;
- gg) active power limit;
- hh) meter event disconnect and reconnect;
- ii) meter event over and under voltage detection;
- jj) meter event alarm detection;
- kk) meter event configuration change;
- ll) meter serial number;
- mm) meter software version;
- nn) date and time; and
- oo) auxiliary meter reading.

The utility shall be able to select a sub-set for display in a particular order as a user-defined display profile.

The energy values to be displayed shall consist of at least six significant digits. The normal display need not indicate any fractions of kWh.

For testing and calibration purposes, the display resolution is given in clause 7.4.

The rate indicator on the CIU need not be used for calibration purposes.

A.12.2 DisplayRemoteInformationOnCIU

The CIU shall receive and display a free-format text message sent from ERPS or HES to the CIU of a single designated customer or to a group of designated customers.

The length of the text string shall be constrained by the capability of the type of interface on the CIU. In general, provision shall be made for text string lengths of 160 characters (see clause 7.4 for particular requirements).

The CIU shall also receive and display the following information sent from the HES or HHU:

- a) notification of impending supply disconnection when in post-payment mode;
- b) notification of impending supply interruption;
- c) notification of impending power limit reduction;
- d) notification of appliance disconnection; and
- e) notification of appliance reconnection.

A.13 Configuration control**A.13.1 General**

The metering system is able to automatically configure new devices introduced into a particular area, provided that they have been correctly setup by the field technician or pre-configured in the factory.

Pre-configuration requirements shall be stated in the purchase agreement.

Firmware updates of a Meter shall not allow changes to the metrological properties of the Meter.

Annex A

(continued)

The device shall push a notification of the event together with the cause of the event to the ERPS or HES on each occasion when a configuration change operation is performed on the device.

Clock synchronization of the real time clock in any device shall ensure that the maximum deviation from actual time shall be less than 5 minutes.

A.13.2 RegisterNetworkGateway/Dataconcentrator

The NG/DC is initialized to a pre-defined state by the manufacturer or by the utility prior to installation, such that it is ready for installation and commissioning.

The NG/DC automatically discovers and connects to the HES, which then registers and configures the NG/DC to make it fully operational.

The NG/DC shall rely on the DHCPv6 service provided by the HES.

A.13.3 RegisterMeter

The meter is initialized to a pre-defined state by the manufacturer or by the utility prior to installation, such that it is ready for installation and commissioning.

The meter automatically discovers and connects to the NG/DC, which routes the connection to the HES. The NG/DC provides the DHCPv6 services.

In the case where the NG/DC is not present, the meter automatically detects and connects to the HES. In this case, the meter shall rely on the DHCPv6 services provided by the HES.

The meter shall be configured by the HES to make it fully operational.

A.13.4 RegisterAuxiliaryMeter

The auxiliary meter is initialized to a pre-defined state by the manufacturer or by the utility prior to installation, such that it is ready for installation and commissioning.

The auxiliary meter automatically discovers and connects to the smart meter as programmed. The meter provides the DHCPv6 services.

The smart meter acts as proxy to the HES and registers the auxiliary meter with the HES.

The configuration of the auxiliary meter via the smart meter to make it fully operational shall be done by the HES.

The detail of this use case will be defined in Part 4 of NRS 049.

A.13.5 ConfigureMeterLocal

The meter is able to receive and processes a request/command to configure programmable parameters in the meter and performs general maintenance procedures when required.

A.13.6 ConfigureNGLocal

The NG/DC is able to receive and processes a request/command to configure programmable parameters in the NG/DC and performs general maintenance procedures when required.

A.13.7 UpdateNGFirmwareRemote

The NG/DC is able to receive a new firmware image of the NG/DC downloaded from the HES and loaded into the NG/DC.

Restart of the new firmware shall be scheduled to automatically occur on a future date and time.

Annex A

(concluded)

A.13.8 UpdateNGFirmwareLocal

The NG/DC is able to receive a new firmware image of the NG/DC downloaded from the HHU and loaded into the NG/DC.

Restart of the new firmware shall be either under manual control or scheduled to automatically occur on a future date and time.

A.13.9 UpdateMeterFirmwareRemote

The meter is able to receive a new firmware image of the meter downloaded from the HES and loaded into the meter.

The installation of the new firmware shall be scheduled to automatically occur on a future date and time.

A.13.10 UpdateMeterFirmwareLocal

The meter is able to receive a new firmware image of the meter downloaded from the HHU and loaded into the meter.

The installation of the new firmware shall be either under manual control or scheduled to automatically occur on a future date and time.

A.13.11 UpdateCIUFirmwareRemote

The CIU is able to receive a new firmware image of the CIU downloaded from the HES and loaded into the CIU.

The installation of the new firmware shall be either under manual control or scheduled to automatically occur on a future date and time.

A.13.12 UpdateCIUFirmwareLocal

The CIU is able to receive a new firmware image of the CIU downloaded from the HHU and loaded into the CIU.

The installation of the new firmware shall be either under manual control or scheduled to automatically occur on a future date and time.

A.13.13 SetNG/DCClockRemote

The NG/DC is able to receive a request/command from the HES to synchronise the NG/DC clock with that of the HES.

A.13.14 SetNGClockLocal

The NG/DC is able to receive a request/command from the HHU to synchronise the NG/DC clock with that of the HHU.

A.13.15 SetMeterClockRemote

The meter is able to receive a request/command from the HES to synchronise the meter clock with that of the HES.

A.13.16 SetMeterClockLocal

The meter is able to receive a request/command from the HHU to synchronise the meter clock with that of the HHU.

Annex B – Dimension for DIN rail mounted meters (informative)

B.1 Single phase DIN rail mounted meters

Dimensions and terminal arrangements for single phase DIN rail mounted meters are given in 5.2.2, 5.2.3 and Figure A.1 (dimensions in mm).

The two neutral terminals may be positioned in any convenient, but practical location at the bottom of the meter.

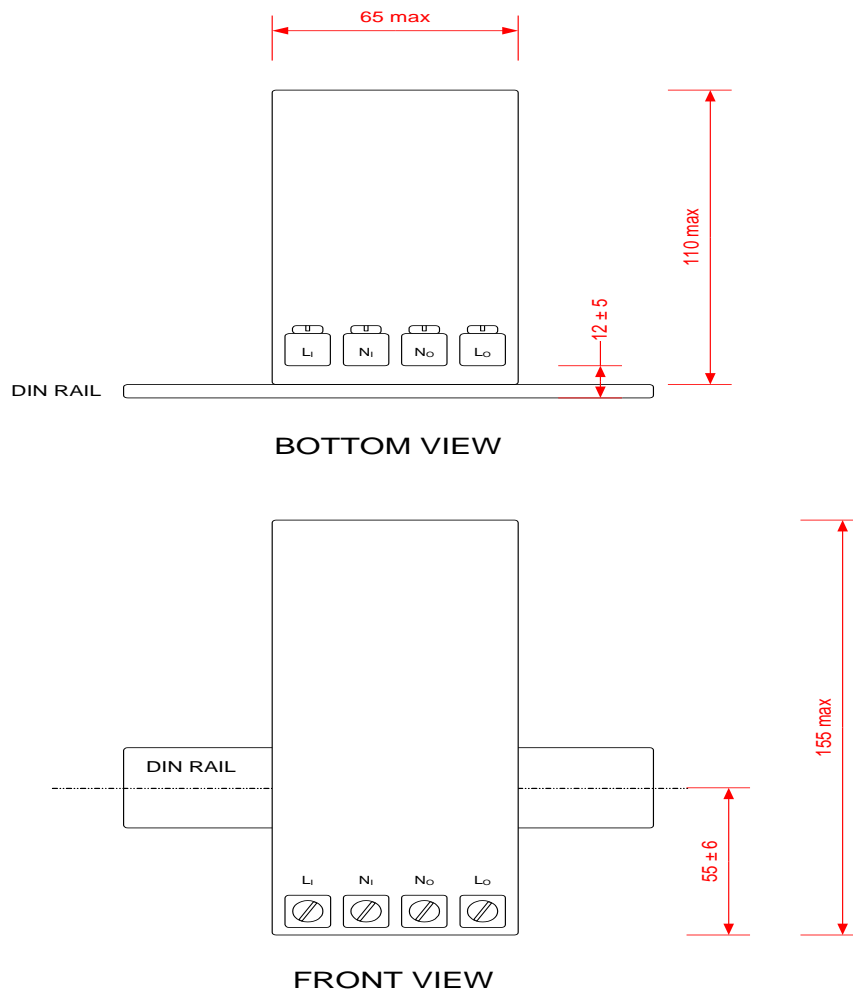

Figure A.1 — Dimensions for single phase DIN rail mounted meters