

PART 4: APPENDICES

C4: LOCALITY MAP

C4: LOCALITY MAP



25A Worcester Street, Makhanda

C5: LAYOUT DRAWINGS

Staircase Additional Support - 1 x A3

THIS DRAWING IS THE CONFIDENTIAL PROPERTY OF ZS2 CONSULTING ENGINEERING AND PROJECT MANAGEMENT AND MAY NOT BE DISCLOSED TO A THIRD PARTY, COPIED OR REPRODUCED IN WHOLE OR IN PART WITHOUT THE PERMISSION OF ZS2 CONSULTING ENGINEERING AND PROJECT MANAGEMENT

GENERAL NOTES

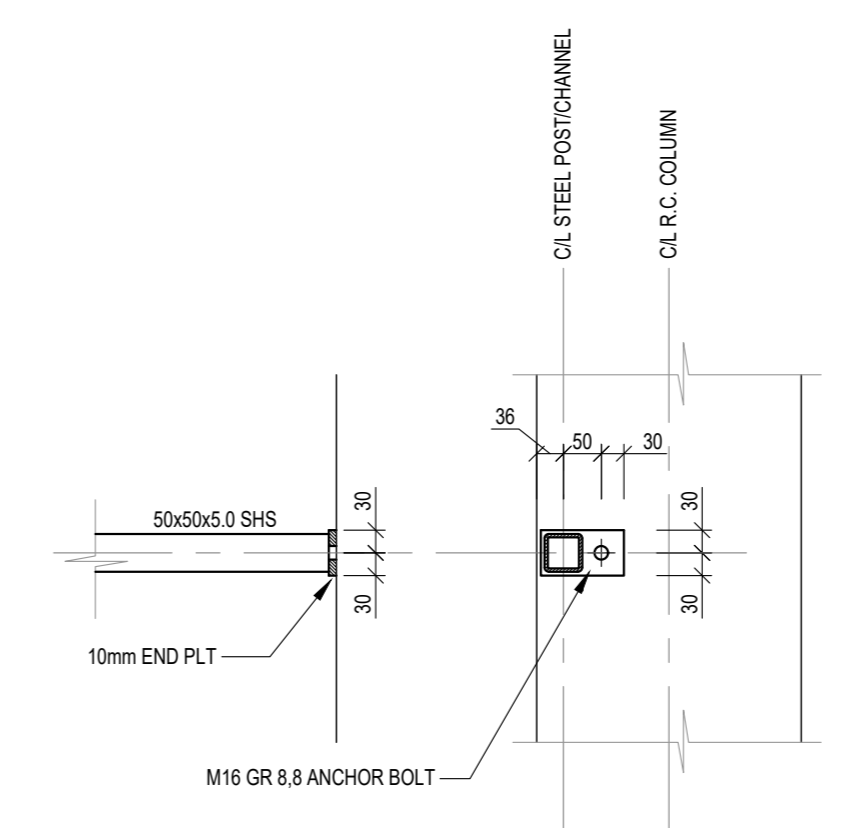
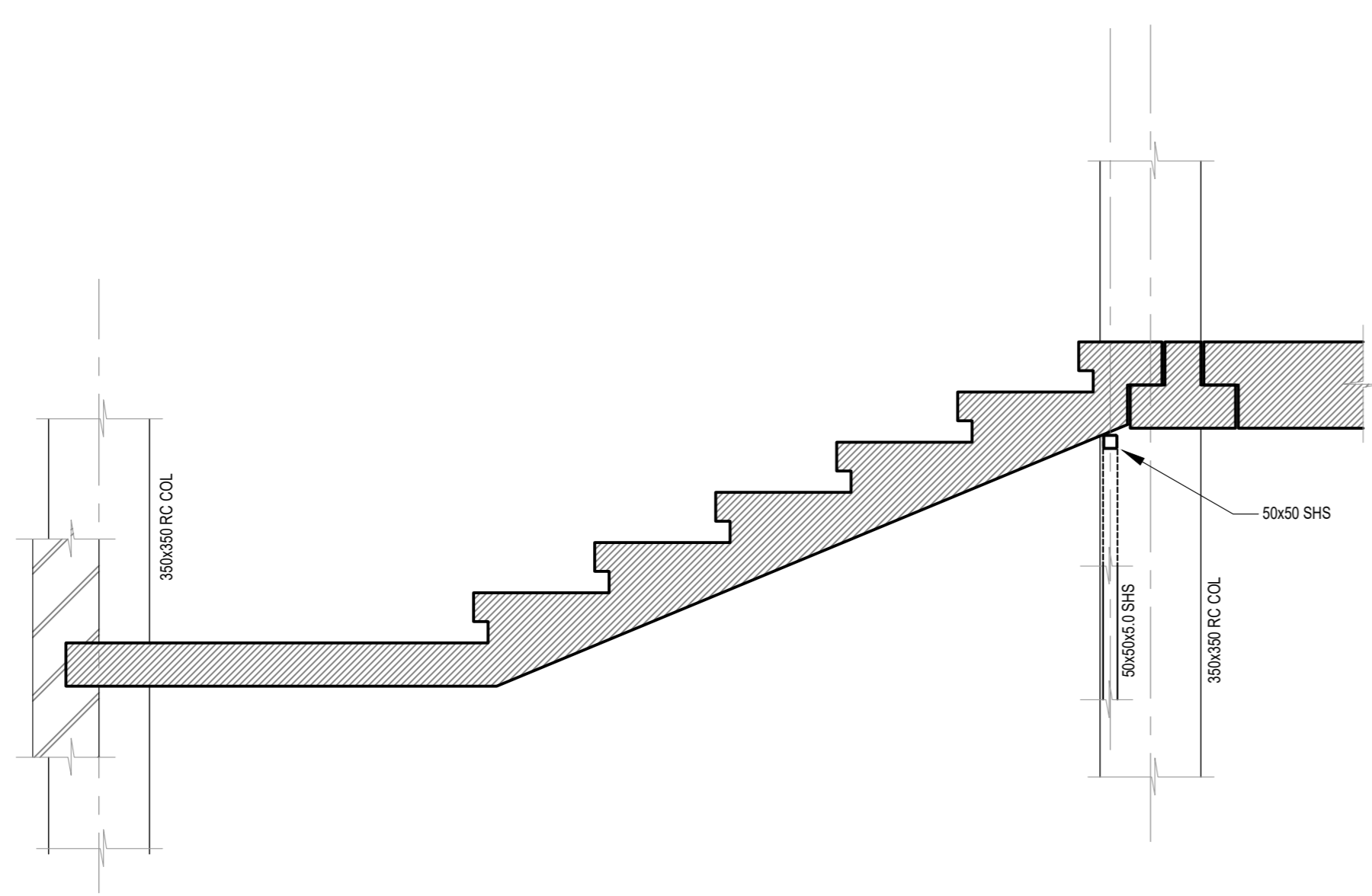

STEEL CHANNEL TO CONCRETE COLUMN DETAIL

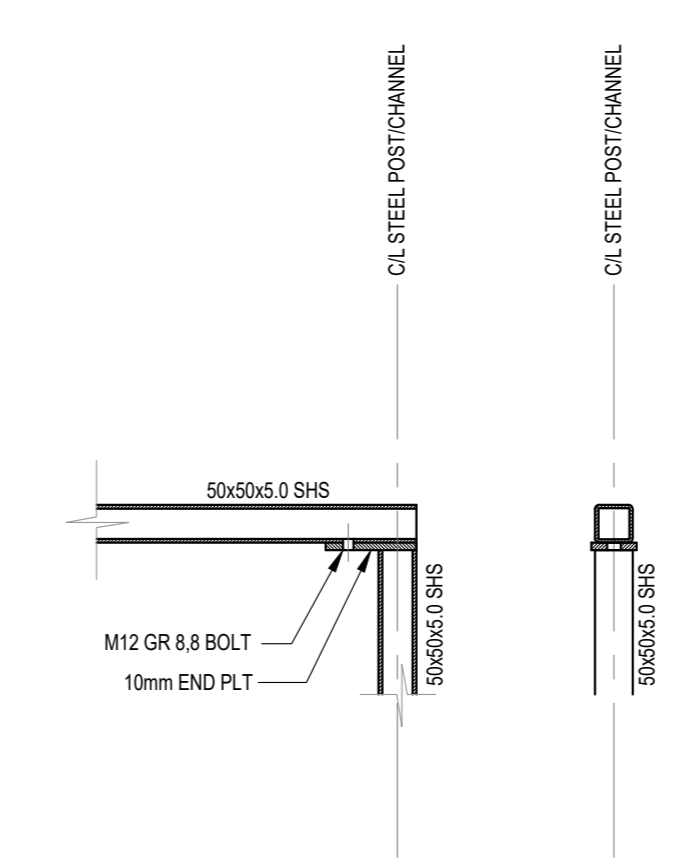
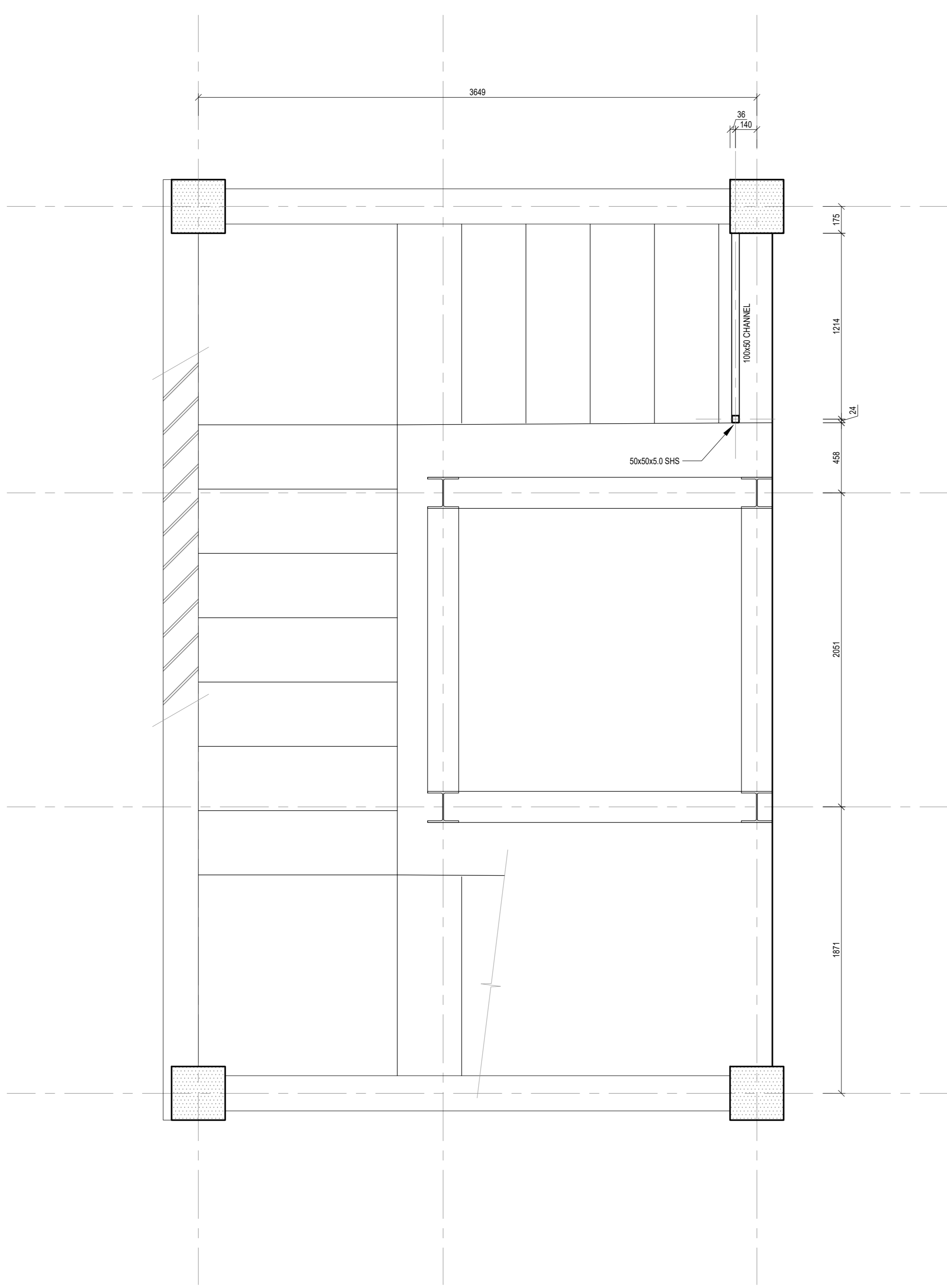

STEEL CHANNEL TO STEEL COLUMN DETAIL

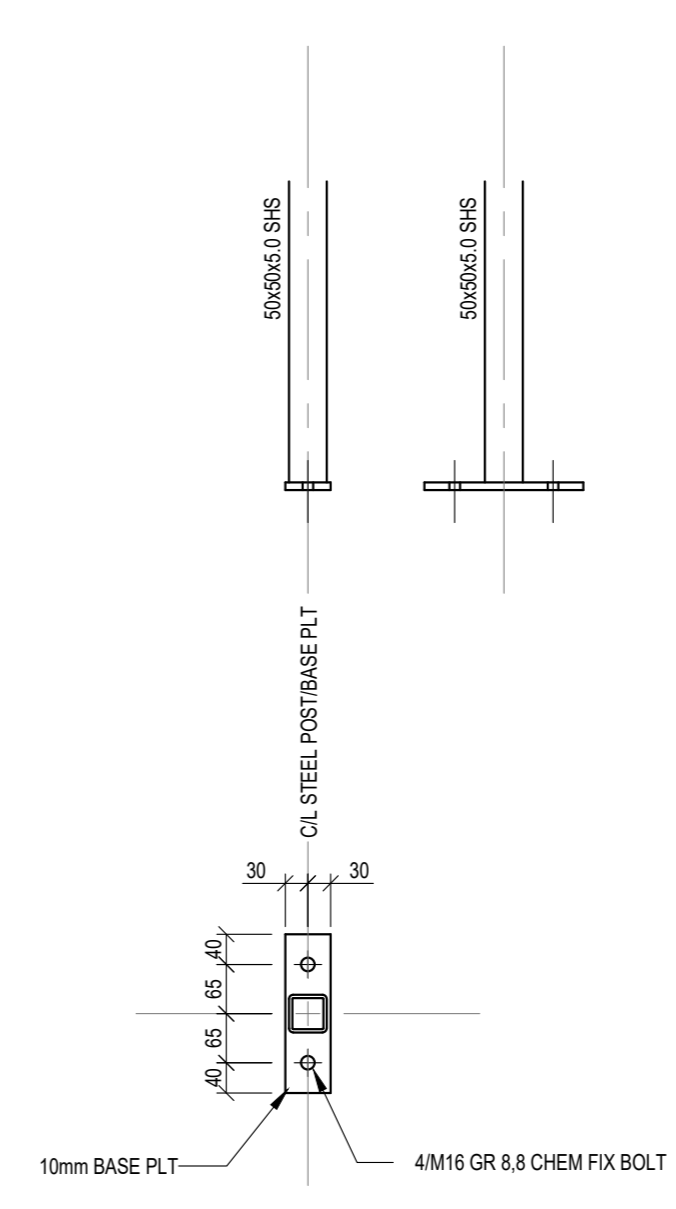

BASE PLATE DETAIL

PROJECT:
AMAZWI SA MUSEUM
OF LITERATURE
MAKHANDA

CLIENT:
DEPARTMENT OF PUBLIC WORKS
AND INFRASTRUCTURE

ISSUED FOR:
FOR CONSTRUCTION

| NO | DATE | REVISION |
|----|----------|-------------------------|
| 0 | 06/05/26 | ISSUED FOR CONSTRUCTION |
| | | |
| | | |
| | | |



DRAWING:
STAIRCASE ADDITIONAL
SUPPORT

SCALE:
AS SHOWN

DATE:
06 MAY 2026

DRAWN:
D. van Wyk

DESIGNED:
H. BSA

APPROVED:
[Signature]

JOB No:
1555.00

DRAWING No:
201-01

REV:
0