



WESTERN CAPE NATURE CONSERVATION BOARD

TENDER NO. WCNCB 04/07/2026

TENDER DOCUMENT

FOR

**VROLIJKHEID (PV) SOLAR SYSTEM
at Vrolijkheid Nature Reserve, Breede Valley**

March 2026

ISSUED FOR: (CLIENT)

Western Cape Nature Conservation Board

PGWC Shared Services Centre
Corner Bosduif & Volstruis Streets
Bridgetown
Gatesville
CAPE TOWN
7766

Tel: 087 087 9262

PREPARED BY: (CONSULTING ENGINEER)

Bühmann Engineering (Pty) Ltd

Unit 25, Muirfield House
Midpark Business Village
2 Greens Close
Parow
CAPE TOWN
7500

Tel: 021 930 4934

NAME OF TENDERER:

SUMMARY FOR TENDER OPENING PURPOSES (to be completed by Tenderer)

WESTERN CAPE NATURE CONSERVATION BOARD: TENDER NO. WCNCB 04/07/2026

..... **AT**

NAME OF TENDERER :

B-BBEE CONTRIBUTOR STATUS LEVEL:

CIDB CONTRACTOR GRADING :

TOTAL BROUGHT FORWARD FROM FORM OF OFFER C1.1 R.....
(INCLUSIVE OF VAT)

TIME FOR COMPLETION OFFERED :(months)

Details of contact person:

Name:

Telephone No: Fax no

Cellular:

E-mail Address:

Is Form of Offer signed by Tenderer and Witness?

SIGNATURE: Date:
(of person authorised to have signed the tender)

Note: In the event of conflict between the data provided in this summary and that given in the Form of Offer, C1.1, the latter shall prevail.

ISSUED FOR:

Western Cape Nature Conservation Board

**PGWC Shared Services Centre
Corner Bosduif & Volstruis Streets
Bridgetown
Gatesville
CAPE TOWN
7766**

Tel: 087 087 9262

PREPARED BY:

Bühmann Consulting Engineers

**Unit 25, Muirfield House
Midpark Business Village
2 Greens Close
Parow
CAPE TOWN
7500**

Tel: 021 930 4934

LIST OF PROJECT DOCUMENTS

The Tender Documents for this Contract comprise the following:

- 1: The **JBCC Minor Works Agreement (May 2018 Edition 5.2)** prepared by the Joint Building Contracts Committee shall be the applicable building agreement and the **JBCC General Preliminaries (May 2018 Edition 6.2)** for use with the JBCC Minor Works Agreement Edition 5.1 shall be deemed to be incorporated in the agreement, amended as hereinafter described and which the Tenderer shall purchase himself.
- 2: The SANS Standardized Specification for Civil and Electrical Engineering Construction, prepared by Standards South Africa, which the Tenderer shall purchase himself.
- 3: The Tender Document, containing the Tender Notice, Conditions of Tender, Tender Data, Returnable Schedules, General and Particular Conditions of Contract, Project Specifications, Pricing Schedule, Form of Offer and Site Information, is issued by the Employer. The Employer's Form of Acceptance and any correspondence from the selected Tenderer, Performance Security and all Addenda issued during the period of tender will also form part of this document once a successful tenderer has been appointed.
- 4: Drawings.

1 are available from the following organisations (as applicable):

- **JBCC, P O Box 3137, Houghton, 2041. Tel: 011 482 3102 Fax: 011 482 4299, email: info@jbcc.co.za**
- **ASAQS, P O Box 3527, Halfway House, 1685. Tel: 011 315 4140, email: info@asaqs.co.za**
- **ASAQS WC Chapter, P O Box 6003, Roggebaai, 8012. Tel: 021 424 7742, Fax: 021 424 6584, email: admin@talani.co.za**

2 are available from the following organisations (as applicable):

- **CESA, PO Box 68482, Bryanston, 2021. Tel: 011 463 2022 Fax: 011 463 7383, email: general@cesa.co.za**
- **SAICE, Private Bag X200, Halfway House, 1685. Tel: 011 805 5947/8, email: civilinfo@saice.org.za**
- **SAFCEC**
- **South African Bureau of Standards**

Notes to Tenderer:

1. **3 above is issued at tender stage in electronic format (e-mail) and contains the following files:**

- **The full Tender Document in PDF format**
- **The returnable forms in word PDF format**
- **The pricing data in PDF and excel format**

At contract stage 3 above will be a bound signed paper copy containing the following documents:

- **Returnable schedules relevant to the project**
- **Agreements and Contract Data**
- **Pricing Data**
- **Scope of Work**
- **Site Information**

2. **SUBMISSION OF TENDER – Of the Contract Documents, only the following elements of 3 above need to be submitted in a neatly bound file and in the following order:**

- **Form of Offer**
- **All returnable schedules**
- **Completed Pricing Schedule**

(iv)

Information provided by a Tenderer over and above the above elements of 3 shall be treated as information only and will only be bound into the document if the Tenderer notes on *Form A10: Proposed Amendments and Qualifications by Tenderer* that the information has a bearing on the Tender price.

3. For alternative offers the Tenderer shall submit the following additional documentation, clearly marked as ALTERNATIVE, in a separate neatly bound file in the following order:

- Form of Offer copy from CD and state "Alternative Form of Offer"
- All returnable schedules applicable to alternative offer, as is appropriate
- Alternative Pricing Schedule
- Other relevant information.

Supplier Database Registration

All **prospective** Service Providers must be registered on:

- a) The Western Cape Supplier Database and;
- b) Central Supplier Database

All **prospective** Service Providers are invited to register as a supplier on the **Western Cape Supplier Database**. Enquiries regarding the registration process may be referred to Procurement Client Centre at the Western Cape Government Supplier Helpdesk on **021 833 5361** or wcseb@westerncape.gov.za.

All **prospective** Service Providers who are not registered on the **Central Supplier Database** are requested to self-register on <https://secure.csd.gov.za/>.

All Service Providers who are currently registered on the **Western Cape Supplier Database** are also invited to update their status by contacting the Western Cape Government Supplier Helpdesk on **021 833 5361** or wcseb@westerncape.gov.za.

WESTERN CAPE NATURE CONSERVATION BOARD

TENDER NO. **WCNCB 04/07/2026**FOR **VROLIJKHEID (PV) SOLAR SYSTEM at Vrolijkheid Nature Reserve, Breede Valley****CONTENTS**

		<u>PAGE(S)</u>	<u>COLOUR</u>
THE TENDER			
PART T1:	TENDERING PROCEDURES.....	T1.1 – T1.15	White
T1.1	Tender Notice and Invitation to Tender	T1.2	White
T1.2	Tender Data	T1.3 – T1.15	White
PART T2:	RETURNABLE DOCUMENTS.....	T2.1 – T2.48	White
T2.1	List of Returnable Documents	T2.2	White
T2.2	Returnable Schedules	T2.3 – T2.48	White
THE CONTRACT			
PART C1:	AGREEMENTS AND CONTRACT DATA.....	C1.1 – C1.25	White
C1.1	Form of Offer and Acceptance	C1.2 – C1.6	White
C1.2	Contract Data	C1.7 – C1.18	White
C1.3	Performance Guarantee (Pro forma).....	C1.19 – C1.21	White
C1.4	Agreement in Terms of Occupational Health and Safety Act, 1993 (Act No 85 of 1993).....	C1.22 – C1.25	White
PART C2:	PRICING DATA.....	C2.1 – C2.4	White
C2.1	Pricing Instructions	C2.2 – C2.3	White
C2.2	Bill of Quantities	C2.4	White
PART C3:	SCOPE OF WORK.....	C3.1 – C3.2	White
C3.1	Description of the Works	C3.2	White
C3.2	Environmental Specification	C3.2	White
C3.3	Electrical Specification	C3.2	White
PART C4:	SITE INFORMATION	C4.1 – C4.5	White
C4.1	Annexures	C4.1	White
Annexure A	Bills of Quantities.....	C4.2	White
Annexure B	Tender Specification.....	C4.3	White
Annexure C	Drawings	C4.4	White
Annexure D	Environmental Specification	C4.5	White

WESTERN CAPE NATURE CONSERVATION BOARD

TENDER NO. **WCNCB 04/07/2026**

FOR **VROLIJKHEID (PV) SOLAR SYSTEM at Vrolijkheid Nature Reserve, Breede Valley**

THE TENDER

PART T1 TENDERING PROCEDURES..... T1.1 – T1.15

PART T2 RETURNABLE DOCUMENTS..... T2.1 – T2.48

WESTERN CAPE NATURE CONSERVATION BOARD

TENDER NO. **WCNCB 04/07/2026**

FOR **VROLIJKHEID (PV) SOLAR SYSTEM at Vrolijkheid Nature Reserve, Breede Valley**

PART T1 TENDERING PROCEDURES

T1.1 TENDER NOTICE AND INVITATION TO TENDER..... T1.2

T1.2 TENDER DATA T1.3 – T1.15

Annex C: Standard Conditions of Tender (as published in Government Gazette No 42622 of 8 August 2019) bound directly after Tender Data

WESTERN CAPE NATURE CONSERVATION BOARD

TENDER NO. **WCNCB 04/07/2026**

FOR **VROLIJKHEID (PV) SOLAR SYSTEM at Vrolijkheid Nature Reserve, Breede Valley**

T1.1 TENDER NOTICE AND INVITATION TO TENDER

Bührmann Consulting Engineers, on behalf of the WESTERN CAPE NATURE CONSERVATION BOARD, invites tenders for the **VROLIJKHEID (PV) SOLAR SYSTEM at Vrolijkheid Nature Reserve, Breede Valley**.

It is estimated that tenderers should have a CIDB contractor grading of **4 EB or higher**

Please note that this tender will be evaluated in terms of functionality. The minimum threshold will be 70% of the 100 points awarded for functionality as specified on the Functionality Table included in Part T2.

Tenders will be evaluated using the 80/20 preference point system which awards points on the basis of 80 points for price and 20 points for their B-BBEE contribution level. Points will be awarded as specified on the Preference Points Claim Form included in Part T2.

Documents may be downloaded from: www.capenature.co.za

Queries relating to the issue of these documents may be addressed to: *Mr Braam Human, Tel No: 021 930 4934, e-mail: braam@buhrmannce.co.za*

A **COMPULSORY** briefing session will be held at Vrolijkheid Nature Reserve on 14 July 2026, at 11h00.

Directions to Vrolijkheid Nature Reserve:

From Cape Town: Take the N1 highway towards Paarl and travel for about 110km. Turn right onto the R60 and then left onto Robertson Road. Continue along this road and then turn right onto Reitz Street. About 13km further along, you will find the entrance gates of the reserve. This route is about 171km and should take about two hours.

GPS: 33°55'3.84" S 19°52'39.04"E

The **closing time** for receipt of tenders is **11h00 on Tuesday, 4 August 2026**, at the CapeNature Head Office, PGWC Shared Services Centre, 3rd Floor, Corner Bosduif & Volstruis Streets, Bridgetown, Gatesville, 7766.

Tenders may also be emailed to tenders@capenature.co.za before the above mentioned closing time.

Telegraphic, telephonic, telex, facsimile, posted, and late tenders will not be accepted.

Requirements for documents to be submitted, sealing, addressing, delivery, opening and assessment of tenders are stated in the Tender Data and the Notes to Tenderers on pg. (iii).

WESTERN CAPE NATURE CONSERVATION BOARD

TENDER NO. **WCNCB 04/07/2026**

FOR **VROLIJKHEID (PV) SOLAR SYSTEM at Vrolijkheid Nature Reserve, Breede Valley**

T1.2 TENDER DATA

The Conditions of Tender are the Standard Conditions of Tender as published in Annex C of the CIDB Standard for Uniformity in Construction Procurement in Board Notice 423 of 2019 in the Government Gazette No 42622 of 8 August 2019. A copy is attached directly after this section.

The Standard Conditions of Tender make several references to the Tender Data for details that apply specifically to this Tender. The Tender Data shall have precedence in the interpretation of any ambiguity or inconsistency between it and the Standard Conditions of Tender.

Each item of data given below is cross-referenced to the clause in the Standard Conditions of Tender to which it mainly applies.

C.1.1 The Employer is:

WESTERN CAPE NATURE CONSERVATION BOARD

Physical Address:

PGWC Shared Services Centre
Corner Bosduif & Volstruis Streets
Bridgetown
Gatesville
CAPE TOWN
7766

Tel: 087 087 9262

C.1.2 The Tender Documents issued by the Employer comprise:

THE TENDER

Part T1 Tendering procedures

T1.1 Tender Notice and Invitation to Tender
T1.2 Tender Data

Part T2 Returnable documents

T2.1 List of returnable documents
T2.2 Returnable schedules

THE CONTRACT

Part C1 Agreements and Contract Data

C1.1 Form of Offer and Acceptance
C1.2 Contract Data
C1.3 Performance Guarantee (Pro Forma)
C1.4 Agreement in terms of Occupational Health and Safety Act (Act No 85 of 1993)

Part C2 Pricing Data

- C2.1 Pricing Instructions
- C2.2 Bills of Quantities

Part C3 Scope of Work

- C3.1 Description of the Works
- C3.2 Health and Safety
- C3.3 Environmental Specification
- C3.4 Electrical Specifications

Part C4 Site Information

- C4.1 Annexures

C.1.4 The Employer's agent is:

Name: Bührmann Consulting Engineers
Address: Unit 25, Muirfield House
Midpark Business Village
2 Greens Close
Parow
CAPE TOWN
7500
Contact person: Braam human
Tel: 021 930 4934
Email: braam@buhrmannce.co.za

Add the following:

"Tenderers shall note that verbal information given by the Employer's agent during clarification meetings, site visits or at any time prior to the award of the Contract will not be regarded as binding on the Employer. Only information issued formally in writing in terms of either an Addendum (C.3.2) or a Clarification of a Tender Offer (C.3.10) will be considered as amending the Tender Documents.

C.2.1 Only those tenderers who satisfy the following eligibility criteria are eligible to submit tenders:

C.2.1.2 Only those tenderers who are registered with the CIDB, or are capable of being so registered prior to the evaluation of submissions, in a contractor grading designation equal to or higher than a contractor grading designation determined in accordance with the sum tendered, or a value determined in accordance with Regulation 25(1B) or 25(7A) of the Construction Industry Development Regulations, for a **4EB** or higher class of construction work, are eligible to have their tenders evaluated.

Joint ventures are eligible to submit tenders provided that:

- (1) every member of the joint venture is registered with the CIDB;
- (2) the lead partner has a contractor grading designation in the **4EB** or higher class of construction work; and
- (3) the combined contractor grading designation calculated in accordance with the Construction Industry Development Regulations is equal to or higher than a contractor grading designation determined in accordance with the sum tendered for a **4EB** or higher class of construction work or a value determined in accordance with Regulation 25(1B) or 25(7A) of the Construction Industry Development Regulations.

C.2.13.3 Parts of each tender offer communicated on paper shall be submitted as an original, plus **NIL** copies.

C.2.13.5

C.2.15.1 The Employer's address for delivery of tender offers and identification details to be shown on each tender offer package are:

Location of Tender box: CapeNature Head Office

Physical address: PGWC Shared Services Centre
Corner Bosduif & Volstruis Streets
Bridgetown
Gatesville
CAPE TOWN
7766

Identification details: Tender number: **WCNCB 04/07/2026**
Title of Tender: **VROLIJKHEID (PV) SOLAR SYSTEM at Vrolijkheid
Nature Reserve, Breede Valley**

Email Address: tenders@capenature.co.za

C.2.13.6

C.3.5.1 A two-envelope procedure will **not** be followed.

C.2.13.9 Telephonic or facsimile tender offers will **not** be accepted.

C.2.15 The closing time for submission of tender offers is as stated in the Tender Notice and Invitation to Tender.

C.2.16 The tender offer validity period is 3 months.

C.2.23 The Tenderer is required to submit the following with his tender

- (1) an original valid Tax Clearance Certificate issued by the South African Revenue Services; and
- (2) Proof of Contractor Registration drawn from the Construction Industry Development Board website should be attached to Returnable Schedule Form B2;
- (3) Evidence of registration and proof of good standing with a compensation insurer who is approved by the Department of Labour in terms of Section 80 of the Compensation for Occupational Injuries and Diseases Act (Act No 130 of 1993)(COID). The Tenderer is required to disclose all inspections, investigations and their outcomes conducted by the Department of Labour into the conduct of the Tenderer at a time during the 36 months preceding the date of this Tender (Refer Returnable Schedule Form C1);
- (4) Proof of Registration in respect of each partner, where a tenderer satisfied the CIDB contractor grading designation requirements through the formation of a joint venture;
- (5) Submit their Broad-Based Black Economic Empowerment status level certificate or certified copy thereof issued by a registered verification agency in accordance with the Preferential Procurement Policy Framework Act, 2000; Preferential Procurement Regulations, 2022. Joint ventures/consortiums will qualify for preference points, provided that the entity submits the relevant certificate/score card in terms of Preferential Procurement Regulations, 2022. Note that in the case of unincorporated entities, a verified score card must be submitted with the Tender.

C.3.4 The time and location for opening of the tender offers will be immediately after closing of tenders as stated in C.2.15.

C.3.11.1 The tender evaluation method for the evaluation of all responsive tender offers will be Method 4: Functionality, financial offer and preference.

Rejection of Quotes/Proposals

Any effort by a bidder to influence the bid evaluation, comparisons, or award decisions in any manner, may result in rejection of the bid. CapeNature shall reject a bid if the bidder has committed a proven corrupt or fraudulent act in competing for a particular contract. CapeNature may disregard any bid if the bidder or any of its subcontractors:

- Is not tax compliant
- Have abused the Supply Chain Management (SCM) system of a department or any other government department, agency, or entity.
- Have committed proven fraud or any other improper conduct in relation to such a system.
- Have failed to fulfil any previous contract.
- Supplied incorrect information in the bid documentation.
- CSD Registration.
- Valid Declaration of Interest.

Disclaimer

Details of the award will be published (on the e-tender portal/ other media) by CapeNature under National Treasury Instruction No. 1 of 2015/2016.

Annex C

Standard Conditions of Tender

C.1 General

C.1.1 Actions

C.1.1.1 The employer and each tenderer submitting a tender offer shall comply with these conditions of tender. In their dealings with each other, they shall discharge their duties and obligations as set out in C.2 and C.3, timeously and with integrity, and behave equitably, honestly and transparently, comply with all legal obligations and not engage in anticompetitive practices.

C.1.1.2 The employer and the tenderer and all their agents and employees involved in the tender process shall avoid conflicts of interest and where a conflict of interest is perceived or known, declare any such conflict of interest, indicating the nature of such conflict. Tenderers shall declare any potential conflict of interest in their tender submissions. Employees, agents and advisors of the employer shall declare any conflict of interest to whoever is responsible for overseeing the procurement process at the start of any deliberations relating to the procurement process or as soon as they become aware of such conflict and abstain from any decisions where such conflict exists or recuse themselves from the procurement process, as appropriate.

Note: (1) A conflict of interest may arise due to a conflict of roles which might provide an incentive for improper acts in some circumstances. A conflict of interest can create an appearance of impropriety that can undermine confidence in the ability of that person to act properly in his or her position even if no improper acts result.

(2) Conflicts of interest in respect of those engaged in the procurement process include direct, indirect or family interests in the tender or outcome of the procurement process and any personal bias, inclination, obligation, allegiance or loyalty which would in any way affect any decisions taken.

C.1.1.3 The employer shall not seek and a tenderer shall not submit a tender without having a firm intention and the capacity to proceed with the contract.

C.1.2 Tender Documents

The documents issued by the employer for the purpose of a tender offer are listed in the tender data.

C.1.3 Interpretation

C.1.3.1 The tender data and additional requirements contained in the tender schedules that are included in the returnable documents are deemed to be part of these conditions of tender.

C.1.3.2 These conditions of tender, the tender data and tender schedules which are required for tender evaluation purposes, shall form part of any contract arising from the invitation to tender.

C.1.3.3 For the purposes of these conditions of tender, the following definitions apply:

- a) **conflict of interest** means any situation in which:
 - i) someone in a position of trust has competing professional or personal interests which make it difficult to fulfill his or her duties impartially;
 - ii) an individual or tenderer is in a position to exploit a professional or official capacity in some way for their personal or corporate benefit; or
 - iii) incompatibility or contradictory interests exist between an employee and the tenderer who employs that employee.
- b) **comparative offer** means the price after the factors of a non-firm price and all unconditional discounts it can be utilised to have been taken into consideration;
- c) **corrupt practice** means the offering, giving, receiving or soliciting of anything of value to influence the action of the employer or his staff or agents in the tender process;
- d) **fraudulent practice** means the misrepresentation of the facts in order to influence the tender process or the

award of a contract arising from a tender offer to the detriment of the employer, including collusive practices intended to establish prices at artificial levels;

C.1.4 Communication and employer's agent

Each communication between the employer and a tenderer shall be to or from the employer's agent only, and in a form that can be readily read, copied and recorded. Communications shall be in the English language. The employer shall not take any responsibility for non-receipt of communications from or by a tenderer. The name and contact details of the employer's agent are stated in the tender data.

C.1.5 Cancellation and Re-Invitation of Tenders

C.1.5.1 An employer may, prior to the award of the tender, cancel a tender if-

- a) due to changed circumstances, there is no longer a need for the engineering and construction works specified in the invitation;
- b) funds are no longer available to cover the total envisaged expenditure; or
- c) no acceptable tenders are received.
- d) there is a material irregularity in the tender process.

C.1.5.2 The decision to cancel a tender invitation must be published in the same manner in which the original tender invitation was advertised

C.1.5.3 An employer may only with the prior approval of the relevant treasury cancel a tender invitation for the second time.

C.1.6 Procurement procedures

C.1.6.1 General

Unless otherwise stated in the tender data, a contract will, subject to C.3.13, be concluded with the tenderer who in terms of C.3.11 is the highest ranked or the tenderer scoring the highest number of tender evaluation points, as relevant, based on the tender submissions that are received at the closing time for tenders.

C.1.6.2 Competitive negotiation procedure

C.1.6.2.1 Where the tender data require that the competitive negotiation procedure is to be followed, tenderers shall submit tender offers in response to the proposed contract in the first round of submissions. Notwithstanding the requirements of C.3.4, the employer shall announce only the names of the tenderers who make a submission. The requirements of C.8 relating to the material deviations or qualifications which affect the competitive position of tenderers shall not apply.

C.1.6.2.2 All responsive tenderers or at least a minimum of not less than three responsive tenderers that are highest ranked in terms of the evaluation criteria stated in the tender data shall be invited to enter into competitive negotiations based on the principle of equal treatment, keeping confidential the proposed solutions and associated information.

Notwithstanding the provisions of C.2.17, the employer may request that tenders be clarified, specified and fine-tuned in order to improve a tenderer's competitive position provided that such clarification, specification, fine-tuning or additional information does not alter any fundamental aspects of the offers or impose substantial new requirements which restrict or distort competition or have a discriminatory effect.

C.1.6.2.3 At the conclusion of each round of negotiations, tenderers shall be invited by the employer to revise their tender offer based on the same evaluation criteria, with or without adjusted weightings. Tenderers shall be advised when they are to submit their best and final offer.

C.1.6.2.4 The contract shall be awarded in accordance with the provisions of C.3.11 and C.3.13 after tenderers have been requested to submit their best and final offer.

C.1.6.3 Proposal procedure using the two stage-system

C.1.6.3.1 Option 1

Tenderers shall in the first stage submit technical proposals and, if required, cost parameters around which a contract may be negotiated. The employer shall evaluate each responsive submission in terms of the method of evaluation stated in the tender data, and in the second stage negotiate a contract with the tenderer scoring the highest number of evaluation points and award the contract in terms of these conditions of tender.

C.1.6.3.2 Option 2

C.1.6.3.2.1 Tenderers shall submit in the first stage only technical proposals. The employer shall invite all responsive tenderers to submit tender offers in the second stage, following the issuing of procurement documents.

C.1.6.3.2.2 The employer shall evaluate tenders received during the second stage in terms of the method of evaluation stated in the tender data, and award the contract in terms of these conditions of tender.

C.2 Tenderer's obligations

C.2.1 Eligibility

C.2.1.1 Submit a tender offer only if the tenderer satisfies the criteria stated in the tender data and the tenderer, or any of his principals, is not under any restriction to do business with employer.

C.2.1.2 Notify the employer of any proposed material change in the capabilities or formation of the tendering entity (or both) or any other criteria which formed part of the qualifying requirements used by the employer as the basis in a prior process to invite the tenderer to submit a tender offer and obtain the employer's written approval to do so prior to the closing time for tenders.

C.2.2 Cost of tendering

C.2.2.1 Accept that, unless otherwise stated in the tender data, the employer will not compensate the tenderer for any costs incurred in the preparation and submission of a tender offer, including the costs of any testing necessary to demonstrate that aspects of the offer complies with requirements.

C.2.2.2 The cost of the tender documents charged by the employer shall be limited to the actual cost incurred by the employer for printing the documents. Employers must attempt to make available the tender documents on its website so as not to incur any costs pertaining to the printing of the tender documents.

C.2.3 Check documents

Check the tender documents on receipt for completeness and notify the employer of any discrepancy or omission.

C.2.4 Confidentiality and copyright of documents

Treat as confidential all matters arising in connection with the tender. Use and copy the documents issued by the employer only for the purpose of preparing and submitting a tender offer in response to the invitation.

C.2.5 Reference documents

Obtain, as necessary for submitting a tender offer, copies of the latest versions of standards, specifications, conditions of contract and other publications, which are not attached but which are incorporated into the tender documents by reference.

C.2.6 Acknowledge addenda

Acknowledge receipt of addenda to the tender documents, which the employer may issue, and if necessary apply for an extension to the closing time stated in the tender data, in order to take the addenda into account.

C.2.7 Clarification meeting

Attend, where required, a clarification meeting at which tenderers may familiarize themselves with aspects of the proposed work, services or supply and raise questions. Details of the meeting(s) are stated in the tender data.

C.2.8 Seek clarification

Request clarification of the tender documents, if necessary, by notifying the employer at least five (5) working days before the closing time stated in the tender data.

C.2.9 Insurance

Be aware that the extent of insurance to be provided by the employer (if any) might not be for the full cover required in terms of the conditions of contract identified in the contract data. The tenderer is advised to seek qualified advice regarding insurance.

C.2.10 Pricing the tender offer

C.2.10.1 Include in the rates, prices, and the tendered total of the prices (if any) all duties, taxes except Value Added Tax (VAT), and other levies payable by the successful tenderer, such duties, taxes and levies being those applicable fourteen (14) days before the closing time stated in the tender data.

C.2.10.2 Show VAT payable by the employer separately as an addition to the tendered total of the prices.

C.2.10.3 Provide rates and prices that are fixed for the duration of the contract and not subject to adjustment except as provided for in the conditions of contract identified in the contract data.

C.2.10.4 State the rates and prices in Rand unless instructed otherwise in the tender data. The conditions of contract identified in the contract data may provide for part payment in other currencies.

C.2.11 Alterations to documents

Do not make any alterations or additions to the tender documents, except to comply with instructions issued by the employer, or necessary to correct errors made by the tenderer. All signatories to the tender offer shall initial all such alterations.

C.2.12 Alternative tender offers

C.2.12.1 Unless otherwise stated in the tender data, submit alternative tender offers only if a main tender offer, strictly in accordance with all the requirements of the tender documents, is also submitted as well as a schedule that compares the requirements of the tender documents with the alternative requirements that are proposed.

C.2.12.2 Accept that an alternative tender offer must be based only on the criteria stated in the tender data or criteria otherwise acceptable to the employer.

C.2.12.3 An alternative tender offer must only be considered if the main tender offer is the winning tender.

C.2.13 Submitting a tender offer

C.2.13.1 Submit one tender offer only, either as a single tendering entity or as a member in a joint venture to provide the whole of the works identified in the contract data and described in the scope of works, unless stated otherwise in the tender data.

C.2.13.2 Return all returnable documents to the employer after completing them in their entirety, either electronically (if they were issued in electronic format) or by writing legibly in non-erasable ink.

C.2.13.3 Submit the parts of the tender offer communicated on paper as an original plus the number of copies stated in the tender data, with an English translation of any documentation in a language other than English, and the parts communicated electronically in the same format as they were issued by the employer.

C.2.13.4 Sign the original and all copies of the tender offer where required in terms of the tender data. The employer will hold all authorized signatories liable on behalf of the tenderer. Signatories for tenderers proposing to contract as

joint ventures shall state which of the signatories is the lead partner whom the employer shall hold liable for the purpose of the tender offer.

- C.2.13.5** Seal the original and each copy of the tender offer as separate packages marking the packages as "ORIGINAL" and "COPY". Each package shall state on the outside the employer's address and identification details stated in the tender data, as well as the tenderer's name and contact address.
- C.2.13.6** Where a two-envelope system is required in terms of the tender data, place and seal the returnable documents listed in the tender data in an envelope marked "financial proposal" and place the remaining returnable documents in an envelope marked "technical proposal". Each envelope shall state on the outside the employer's address and identification details stated in the tender data, as well as the tenderer's name and contact address.
- C.2.13.7** Seal the original tender offer and copy packages together in an outer package that states on the outside only the employer's address and identification details as stated in the tender data.
- C.2.13.8** Accept that the employer will not assume any responsibility for the misplacement or premature opening of the tender offer if the outer package is not sealed and marked as stated.
- C.2.13.9** Accept that tender offers submitted by facsimile or e-mail will be rejected by the employer, unless stated otherwise in the tender data.

C.2.14 Information and data to be completed in all respects

Accept that tender offers, which do not provide all the data or information requested completely and in the form required, may be regarded by the employer as non-responsive.

C.2.15 Closing time

- C.2.15.1** Ensure that the employer receives the tender offer at the address specified in the tender data not later than the closing time stated in the tender data. Accept that proof of posting shall not be accepted as proof of delivery.
- C.2.15.2** Accept that, if the employer extends the closing time stated in the tender data for any reason, the requirements of these conditions of tender apply equally to the extended deadline.

C.2.16 Tender offer validity

- C.2.16.1** Hold the tender offer(s) valid for acceptance by the employer at any time during the validity period stated in the tender data after the closing time stated in the tender data.
- C.2.16.2** If requested by the employer, consider extending the validity period stated in the tender data for an agreed additional period with or without any conditions attached to such extension.
- C.2.16.3** Accept that a tender submission that has been submitted to the employer may only be withdrawn or substituted by giving the employer's agent written notice before the closing time for tenders that a tender is to be withdrawn or substituted. If the validity period stated in C.2.16 lapses before the employer evaluating tender, the contractor reserves the right to review the price based on Consumer Price Index (CPI).
- C.2.16.4** Where a tender submission is to be substituted, a tenderer must submit a substitute tender in accordance with the requirements of C.2.13 with the packages clearly marked as "SUBSTITUTE".

C.2.17 Clarification of tender offer after submission

Provide clarification of a tender offer in response to a request to do so from the employer during the evaluation of tender offers. This may include providing a breakdown of rates or prices and correction of arithmetical errors by the adjustment of certain rates or item prices (or both). No change in the competitive position of tenderers or substance of the tender offer is sought, offered, or permitted.

Note: Sub-clause C.2.17 does not preclude the negotiation of the final terms of the contract with a preferred tenderer following a competitive selection process, should the Employer elect to do so.

C.2.18 Provide other material

C.2.18.1 Provide, on request by the employer, any other material that has a bearing on the tender offer, the tenderer's commercial position (including notarized joint venture agreements), preferencing arrangements, or samples of materials, considered necessary by the employer for the purpose of a full and fair risk assessment.

Should the tenderer not provide the material, or a satisfactory reason as to why it cannot be provided, by the time for submission stated in the employer's request, the employer may regard the tender offer as non-responsive.

C.2.18.2 Dispose of samples of materials provided for evaluation by the employer, where required.

C.2.19 Inspections, tests and analysis

Provide access during working hours to premises for inspections, tests and analysis as provided for in the tender data.

C.2.20 Submit securities, bonds and policies

If requested, submit for the employer's acceptance before formation of the contract, all securities, bonds, guarantees, policies and certificates of insurance required in terms of the conditions of contract identified in the contract data.

C.2.21 Check final draft

Check the final draft of the contract provided by the employer within the time available for the employer to issue the contract.

C.2.22 Return of other tender documents

If so instructed by the employer, return all retained tender documents within twenty-eight (28) days after the expiry of the validity period stated in the tender data.

C.2.23 Certificates

Include in the tender submission or provide the employer with any certificates as stated in the tender data.

C.3 The employer's undertakings

C.3.1 Respond to requests from the tenderer

C.3.1.1 Unless otherwise stated in the tender Data, respond to a request for clarification received up to five (5) working days before the tender closing time stated in the Tender Data and notify all tenderers who collected tender documents.

C.3.1.2 Consider any request to make a material change in the capabilities or formation of the tendering entity (or both) or any other criteria which formed part of the qualifying requirements used to prequalify a tenderer to submit a tender offer in terms of a previous procurement process and deny any such request if as a consequence:

- a) an individual firm, or a joint venture as a whole, or any individual member of the joint venture fails to meet any of the collective or individual qualifying requirements;
- b) the new partners to a joint venture were not prequalified in the first instance, either as individual firms or as another joint venture; or
- c) in the opinion of the Employer, acceptance of the material change would compromise the outcome of the prequalification process.

C.3.2 Issue Addenda

If necessary, issue addenda that may amend or amplify the tender documents to each tenderer during the period from the date that tender documents are available until three (3) working days before the tender closing time stated in the Tender Data. If, as a result a tenderer applies for an extension to the closing time stated in the Tender Data, the Employer may grant such extension and, shall then notify all tenderers who collected tender documents.

C.3.3 Return late tender offers

Return tender offers received after the closing time stated in the Tender Data, unopened, (unless it is necessary to open a tender submission to obtain a forwarding address), to the tenderer concerned.

C.3.4 Opening of tender submissions

C.3.4.1 Unless the two-envelope system is to be followed, open valid tender submissions in the presence of tenderers' agents who choose to attend at the time and place stated in the tender data. Tender submissions for which acceptable reasons for withdrawal have been submitted will not be opened.

C.3.4.2 Announce at the meeting held immediately after the opening of tender submissions, at a venue indicated in the tender data, the name of each tenderer whose tender offer is opened and, where applicable, the total of his prices, number of points claimed for its BBEE status level and time for completion for the main tender offer only.

C.3.4.3 Make available the record outlined in C.3.4.2 to all interested persons upon request.

C.3.5 Two-envelope system

C.3.5.1 Where stated in the tender data that a two-envelope system is to be followed, open only the technical proposal of valid tenders in the presence of tenderers' agents who choose to attend at the time and place stated in the tender data and announce the name of each tenderer whose technical proposal is opened.

C.3.5.2 Evaluate functionality of the technical proposals offered by tenderers, then advise tenderers who remain in contention for the award of the contract of the time and place when the financial proposals will be opened. Open only the financial proposals of tenderers, who score in the functionality evaluation more than the minimum number of points for functionality stated in the tender data, and announce the score obtained for the technical proposals and the total price and any points claimed on BBEE status level. Return unopened financial proposals to tenderers whose technical proposals failed to achieve the minimum number of points for functionality.

C.3.6 Non-disclosure

Not disclose to tenderers, or to any other person not officially concerned with such processes, information relating to the evaluation and comparison of tender offers, the final evaluation price and recommendations for the award of a contract, until after the award of the contract to the successful tenderer.

C.3.7 Grounds for rejection and disqualification

Determine whether there has been any effort by a tenderer to influence the processing of tender offers and instantly disqualify a tenderer (and his tender offer) if it is established that he engaged in corrupt or fraudulent practices.

C.3.8 Test for responsiveness

C.3.8.1 Determine, after opening and before detailed evaluation, whether each tender offer properly received:

- a) complies with the requirements of these Conditions of Tender,
- b) has been properly and fully completed and signed, and
- c) is responsive to the other requirements of the tender documents.

C.3.8.2 A responsive tender is one that conforms to all the terms, conditions, and specifications of the tender documents without material deviation or qualification. A material deviation or qualification is one which, in the Employer's opinion, would:

- a) detrimentally affect the scope, quality, or performance of the works, services or supply identified in the Scope of Work,
- b) significantly change the Employer's or the tenderer's risks and responsibilities under the contract, or
- c) affect the competitive position of other tenderers presenting responsive tenders, if it were to be rectified.

Reject a non-responsive tender offer, and not allow it to be subsequently made responsive by correction or withdrawal of the non-conforming deviation or reservation.

C.3.9 Arithmetic errors, omissions and discrepancies

C.3.9.1 Check responsive tenders for discrepancies between amounts in words and amounts in figures. Where there is a discrepancy between the amounts in figures and the amount in words, the amount in words shall govern.

C.3.9.2 Check the highest ranked tender or tenderer with the highest number of tender evaluation points after the evaluation of tender offers in accordance with C.3.11 for:

- a) the gross misplacement of the decimal point in any unit rate;
- b) omissions made in completing the pricing schedule or bills of quantities; or
- c) arithmetic errors in:
 - (i) line item totals resulting from the product of a unit rate and a quantity in bills of quantities or schedules of prices; or
 - (ii) the summation of the prices.

C.3.9.3 Notify the tenderer of all errors or omissions that are identified in the tender offer and either confirm the tender offer as tendered or accept the corrected total of prices.

C.3.9.4 Where the tenderer elects to confirm the tender offer as tendered, correct the errors as follows:

- a) If bills of quantities or pricing schedules apply and there is an error in the line item total resulting from the product of the unit rate and the quantity, the line item total shall govern and the rate shall be corrected. Where there is an obviously gross misplacement of the decimal point in the unit rate, the line item total as quoted shall govern, and the unit rate shall be corrected.
- b) Where there is an error in the total of the prices either as a result of other corrections required by this checking process or in the tenderer's addition of prices, the total of the prices shall govern and the tenderer will be asked to revise selected item prices (and their rates if bills of quantities apply) to achieve the tendered total of the prices.

C.3.10 Clarification of a tender offer

Obtain clarification from a tenderer on any matter that could give rise to ambiguity in a contract arising from the tender offer.

C.3.11 Evaluation of tender offers

The Standard Conditions of Tender standardize the procurement processes, methods and procedures from the time that tenders are invited to the time that a contract is awarded. They are generic in nature and are made project specific through choices that are made in developing the Tender Data associated with a specific project.

Conditions of tender are by definition the document that establishes a tenderer's obligations in submitting a tender and the employer's undertakings in soliciting and evaluating tender offers. Such conditions establish the rules from the time a tender is advertised to the time that a contract is awarded and require employers to conduct the process of offer and acceptance in terms of a set of standard procedures.

The CIDB Standard Conditions of Tender are based on a procurement system that satisfies the following system requirements:	
Requirement	Qualitative interpretation of goal
Fair	The process of offer and acceptance is conducted impartially without bias, providing simultaneous and timely access to participating parties to the same information.
Equitable	Terms and conditions for performing the work do not unfairly prejudice the interests of the parties.
Transparent	The only grounds for not awarding a contract to a tenderer who satisfies all requirements are restrictions from doing business with the employer, lack of capability or capacity, legal impediments and conflicts of interest.
Competitive	The system provides for appropriate levels of competition to ensure cost effective and best value outcomes.
Cost effective	The processes, procedures and methods are standardized with sufficient flexibility to attain best value outcomes in respect of quality, timing and price, and least resources to effectively manage and control procurement processes.

The activities associated with evaluating tender offers are as follows:

- a) Open and record tender offers received
- b) Determine whether or not tender offers are complete

- c) Determine whether or not tender offers are responsive
- d) Evaluate tender offers
- e) Determine if there are any grounds for disqualification
- f) Determine acceptability of preferred tenderer
- g) Prepare a tender evaluation report
- h) Confirm the recommendation contained in the tender evaluation report

C.3.11.1 General

The employer must appoint an evaluation panel of not less than three persons conversant with the proposed scope of works to evaluate each responsive tender offer using the tender evaluation methods and associated evaluation criteria and weightings that are specified in the tender data.

C.3.12 Insurance provided by the employer

If requested by the proposed successful tenderer, submit for the tenderer's information the policies and / or certificates of insurance which the conditions of contract identified in the contract data, require the employer to provide.

C.3.13 Acceptance of tender offer

Accept the tender offer; if in the opinion of the employer, it does not present any risk and only if the tenderer:

- a) is not under restrictions, or has principals who are under restrictions, preventing participating in the employer's procurement;
- b) can, as necessary and in relation to the proposed contract, demonstrate that he or she possesses the professional and technical qualifications, professional and technical competence, financial resources, equipment and other physical facilities, managerial capability, reliability, experience and reputation, expertise and the personnel, to perform the contract;
- c) has the legal capacity to enter into the contract;
- d) is not; insolvent, in receivership, under Business Rescue as provided for in chapter 6 of the Companies Act No. 2008, bankrupt or being wound up, has his/her affairs administered by a court or a judicial officer, has suspended his/her business activities or is subject to legal proceedings in respect of any of the foregoing;
- e) complies with the legal requirements, if any, stated in the tender data; and
- f) is able, in the opinion of the employer, to perform the contract free of conflicts of interest.

C.3.14 Prepare contract documents

C.3.14.1 If necessary, revise documents that shall form part of the contract and that were issued by the employer as part of the tender documents to take account of:

- a) addenda issued during the tender period,
- b) inclusion of some of the returnable documents and
- c) other revisions agreed between the employer and the successful tenderer.

C.3.14.2 Complete the schedule of deviations attached to the form of offer and acceptance, if any.

C.3.15 Complete adjudicator's contract

Unless alternative arrangements have been agreed or otherwise provided for in the contract, arrange for both parties to complete formalities for appointing the selected adjudicator at the same time as the main contract is signed.

C.3.16 Registration of the award

An employer must, within twenty-one (21) working days from the date on which a contractor's offer to perform a construction works contract is accepted in writing by the employer, register and publish the award on the cidb Register of Projects.

C.3.17 Provide copies of the contracts

Provide to the successful tenderer the number of copies stated in the Tender Data of the signed copy of the contract as soon as possible after completion and signing of the form of offer and acceptance.

C.3.18 Provide written reasons for actions taken

Provide upon request written reasons to tenderers for any action that is taken in applying these conditions of tender but withhold information which is not in the public interest to be divulged, which is considered to prejudice the legitimate commercial interests of tenderers or might prejudice fair competition between tenderers.

WESTERN CAPE NATURE CONSERVATION BOARD

TENDER NO. **WCNCB 04/07/2026**

FOR **VROLIJKHEID (PV) SOLAR SYSTEM at Vrolijkheid Nature Reserve, Breede Valley**

PART T2 RETURNABLE DOCUMENTS

T2.1 LIST OF RETURNABLE DOCUMENTS..... T2.2

T2.2 RETURNABLE SCHEDULES..... T2.3 – T2.48

WESTERN CAPE NATURE CONSERVATION BOARD

TENDER NO. **WCNCB 04/07/2026**

FOR **VROLIJKHEID (PV) SOLAR SYSTEM at Vrolijkheid Nature Reserve, Breede Valley**

T2.1 LIST OF RETURNABLE DOCUMENTS

The Tenderer must complete the following returnable documents:

- 1 RETURNABLE SCHEDULES REQUIRED FOR TENDER EVALUATION PURPOSES
- 2 OTHER DOCUMENTS REQUIRED FOR TENDER EVALUATION PURPOSES
- 3 RETURNABLE SCHEDULES THAT WILL BE INCORPORATED INTO THE CONTRACT
- 4 OTHER DOCUMENTS THAT WILL BE INCORPORATED INTO THE CONTRACT
- 5 C1.1 OFFER AND ACCEPTANCE (INCLUDED IN PART C1: AGREEMENT AND CONTRACT DATA)
- 6 C1.2 CONTRACT DATA (PART 2) DATA PROVIDED BY THE CONTRACTOR (INCLUDED IN PART C1: AGREEMENT AND CONTRACT DATA)
- 7 C2.2 BILL OF QUANTITIES (INCLUDED IN PART C2: PRICING DATA)

WESTERN CAPE NATURE CONSERVATION BOARD

TENDER NO. **WCNCB 04/07/2026**

FOR **VROLIJKHEID (PV) SOLAR SYSTEM at Vrolijkheid Nature Reserve, Breede Valley**

T2.2 RETURNABLE SCHEDULES

The Tenderer must complete the following returnable documents.

T2.2.1 RETURNABLE SCHEDULES REQUIRED FOR TENDER EVALUATION PURPOSES

Form A1:	Authority for Signatory.....	T2.5
Form A2:	Schedule of Work carried out by Tenderer.....	T2.6
Form A3:	Proposed Key Personnel.....	T2.7
Form A4:	Schedule of Constructional Plant.....	T2.9
Form A5:	Company Organogram & Business Profile.....	T2.10
Form A6:	Schedule of Proposed Subcontractors.....	T2.11
Form A7:	Financial References.....	T2.12
Form A8:	Schedule of Current Commitments.....	T2.13
Form A9:	Estimated Monthly Expenditure.....	T2.14
Form A10:	Details of Alternative Tenders Submitted.....	T2.15
Form A11:	Proposed Amendments and Qualifications by Tenderer.....	T2.16
Form A12:	Tax Compliance Status.....	T2.17
Form A13:	Certificate of Insurance Cover.....	T2.18
Form A14:	Preliminary Construction Programme.....	T2.19
Form A15:	Data Sheets (N/A).....	T2.20
Form A16:	Returnable Document Checklist.....	T2.21

T2 . 4

T2.2.2 OTHER DOCUMENTS REQUIRED FOR TENDER EVALUATION PURPOSES

Form B1:	Proof of Registration with Construction Industry Development Board	T2.22
Form B2:	Form Concerning Fulfilment of the Construction Regulations, 2014	T2.23
Form B3:	Record of Addenda to Tender Documents	T2.25
Form B4:	Letter of Intent to provide a JBCC MWA Guarantee for Construction	T2.26

T2.2.3 RETURNABLE SCHEDULES THAT WILL BE INCORPORATED IN THE CONTRACT

Form C1:	Compulsory Enterprise Questionnaire	T2.27
Form C2:	Functionality Table	T2.30
Form C3:	Preferencing Schedules: Preference Points Claim Form in Terms of Preferential Procurement Regulations 2022 (WCBD 6.1)	T2.31
Form C4:	Declaration of Interest (WCBD 4)	T2.38
Form C5:	Certificate of Independent Bid Determination (SBD 9)	T2.45

T2.2.4 OTHER DOCUMENTS THAT WILL BE INCLUDED IN THE CONTRACT

Not Applicable

FORM A1 AUTHORITY FOR SIGNATORY

Signatories for close corporations and companies shall confirm their authority by attaching to this form a duly signed and dated copy of the relevant resolution of their members or their board of directors, as the case may be.

An example for a company is shown below:

"By resolution of the board of directors passed at a meeting held on *[date]*

Mr/Mrs

whose signature appears below, has been duly authorised to sign all documents in connection with the Tender for Contract No and any contract which may arise therefrom on behalf of:

(BLOCK CAPITALS)
.....
.....

SIGNED ON BEHALF OF THE COMPANY :

IN HIS CAPACITY AS :

DATE :

FULL NAMES OF SIGNATORY :
NAME (PRINT)

SIGNATURE OF SIGNATORY :

AS WITNESSES 1 :
NAME (PRINT)

.....
SIGNATURE

2 :
NAME (PRINT)

.....
SIGNATURE

FORM A2 SCHEDULE OF WORK CARRIED OUT BY TENDERER

The Tenderer shall list below the contracts of a similar nature awarded to him in accordance with requirements of the Functionality Table (Form C2). This information is material to the award of the Contract.

EMPLOYER (Name, tel no and fax no)	PRINCIPAL AGENT / CONSULTING ENGINEER (Name, tel no and fax no)	NATURE OF WORK	VALUE OF WORK	YEAR OF COMPLETION

SIGNED ON BEHALF OF TENDERER:

FORM A4 SCHEDULE OF CONSTRUCTIONAL PLANT

The Tenderer shall state below what Constructional Plant will be available for the work should he be awarded the Contract.

DESCRIPTION, SIZE, CAPACITY	NUMBER

SIGNED ON BEHALF OF TENDERER:

FORM A5 COMPANY ORGANOGRAM & BUSINESS PROFILE

The Tenderer shall provide a company organogram and business profile with an overview of your company structure, registration (CIPC), business profile and memberships. This information is material to the award of the Contract.

The following documents must be included:

- Company Organogram
- Business Profile
- CIPC registration documents
- Proof of registration & good standing at SAPVIA and/or SESSA
- Proof of permanent employment of electrician
- Proof of registration & good standing of electrician at Department of Labour

SIGNED ON BEHALF OF TENDERER:

FORM A6 SCHEDULE OF PROPOSED SUBCONTRACTORS

The Tenderer shall, in accordance with the provisions of Conditions of Tender, list below the subcontractors he proposes to employ for part(s) of the work.

The naming of any proposed subcontractor hereunder shall not be deemed to constitute a qualification of the Tender, and acceptance of a tender shall not be construed as approval of any or all of the listed subcontractors, neither shall it in any way limit or detract from the powers of the Engineer and the obligations of the Contractor pertaining to subcontracting as stated in the Contract, nor shall it prevent the Tenderer from deviating in any way during the Contract from the list of proposed subcontractors hereunder if the Tender is accepted.

If any or all of the subcontractors listed hereunder are not approved subsequent to acceptance of the Tender, it shall in no way invalidate the Tender or the Contract, and the tendered unit rates for the respective items of work shall remain final and binding even if a subcontractor not listed below is approved by the Employer.

PART OR TYPE OF WORK	PROPOSED SUBCONTRACTOR	WORK RECENTLY EXECUTED BY SUBCONTRACTOR

SIGNED ON BEHALF OF TENDERER:

FORM A7 FINANCIAL REFERENCES**Financial Statements**

I/We agree, if required, to furnish an audited copy of the latest set of financial statements together with my/our Directors' and Auditors' report for consideration by the Employer.

Details of Company's Bank

I/We hereby authorise the Employer/Engineer to approach all or any of the following banks for the purposes of obtaining a financial reference:

DESCRIPTION OF BANK DETAIL	BANK DETAILS APPLICABLE TO TENDERER'S HEAD OFFICE
Name of bank	
Branch name	
Branch code	
Street address	
Postal address	
Name of manager	
Telephone number	
Fax number	
Account number	

Tenderer's Tax Details

Tenderer's VAT vendor registration number:

Tenderer's SARS tax reference number:

SIGNED ON BEHALF OF TENDERER:

FORM A8 SCHEDULE OF CURRENT COMMITMENTS

Notes to Tenderer:

1. The Tenderer shall list below all Contracts currently under construction or awarded and about to commence and tenders for which offers have been submitted but awards not yet made.
2. In the event of a joint venture enterprise, details of all the members of the joint venture shall similarly be attached to this form.
3. The lists must be restricted to not more than 20 Contracts and 20 Tenders. If a tenderer's actual commitments or potential commitments are greater than 20 each, those listed should be in descending order of expected final contract value or sum tendered.

Table 1 Contracts awarded				
Employer	Project	Expected total value of contract (incl. VAT)	Duration (Months)	Expected completion date

Table 2 TENDERS NOT YET AWARDED				
Employer	Project	Sum Tendered (incl. VAT)	Tendered Duration (Months)	Expected commencement

SIGNED ON BEHALF OF TENDERER:

FORM A9 ESTIMATED MONTHLY EXPENDITURE

The Tenderer shall state below the estimated value of work to be completed every month, based on his preliminary programme and his tendered unit rates.

MONTH	VALUE
1	R
2	R
3	R
	COMPLETION OF CONTRACT
TOTAL	R

SIGNED ON BEHALF OF TENDERER:

FORM A10 DETAILS OF ALTERNATIVE TENDERS SUBMITTED

The Tenderer shall in accordance with C.2.12 submit a conforming tender in order that any alternative be considered responsive. The alternative shall be required as a minimum to conform in all respects to the specifications.

DESCRIPTION

SIGNED ON BEHALF OF TENDERER:

FORM A11 PROPOSED DEVIATIONS AND QUALIFICATIONS BY TENDERER

The Tenderer should record any **proposed** deviations or qualifications he may wish to make to the Tender Documents in this Returnable Schedule. Alternatively, a tenderer may state such proposed deviations and qualifications in a covering letter attached to his tender and reference such letter in this schedule.

The Tenderer's attention is drawn to clause C.3.8 of the Standard Conditions of Tender referenced in the Tender Data regarding the Employer's handling of material deviations and qualifications.

If no deviations or modifications are desired, the schedule hereunder is to be marked **NIL** and signed by the Tenderer.

PAGE	CLAUSE OR ITEM	DESCRIPTION

SIGNED ON BEHALF OF TENDERER:

FORM A12 CERTIFICATE OF TAX CLEARANCE

TAX CLEARANCE CERTIFICATE REQUIREMENTS

It is a condition of bid that the taxes of the successful bidder must be in order, or that satisfactory arrangements have been made with South African Revenue Service (SARS) to meet the bidder's tax obligations.

- 1 In order to meet this requirement bidders are required to submit a valid Tax Compliance Status (TCS) with Unique Personal Identification Number (PIN) issued by SARS to enable the organ of state to view the taxpayer's profile and tax status. The TCS Requirements are also applicable to foreign bidders / individuals who wish to submit bids.
- 2 A printed TCS with PIN may also be submitted together with the bid. Failure to submit the valid TCS will result in the invalidation of the bid.
- 3 In bids where Consortia / Joint Ventures / Sub-contractors are involved, each party must submit a separate TCS.
- 4 Applications for the TCS may be made via eFiling. In order to use this provision, taxpayers will need to register with SARS as eFilers through the website www.sars.gov.za.

SIGNED ON BEHALF OF TENDERER:

FORM A13 CERTIFICATE OF INSURANCE COVER

Note to Tenderer:

In the event of the Tenderer being a joint venture/consortium, the details of the individual members must also be provided.

The Tenderer shall provide the following details of this insurance cover:

- i) Name of Tenderer:
- ii) Period of Validity:
- iii) Value of Insurance:
 - Insurance for Works and Contractor's equipment
Company:
Value:
 - Insurance for Contractor's personnel
Company:
Value:
 - General public liability
Company:
Value:
 - SASRIA
Company:
Value:

SIGNED ON BEHALF OF TENDERER:

FORM A14 PRELIMINARY CONSTRUCTION PROGRAMME

Note to Tenderer:

If a tenderer wishes to submit an alternative tender then this form, appropriately completed, shall be attached to the Pricing Schedule for the alternative proposal.

The Tenderer shall attach a preliminary programme, to this Form.

This programme shall:

- be in the form of a bar chart (Gantt chart) or similar acceptable time/activity form reflecting the proposed sequence and tempo of execution of the various activities and the quantities that will be carried out every week under each of the elements, comprising the work for this contract;
- also indicate the point where the Tenderer intends to commence work operations and the direction in which the work will proceed;
- be in accordance with the information provided in Form A4: Schedule of Constructional Plant, Form A8: Estimated monthly expenditure, and with all other aspects of the Tender; and
- indicate planned working hours.

Details of the preliminary programme shall be appended to this Form.

Number of sheets, appended by the Tenderer to this Form *[If NIL, enter NIL]*

SIGNED ON BEHALF OF TENDERER:

FORM A15 DATA SHEETS

The Tenderer shall complete and attach the Data Sheets (Annexure C), to this Form.

The following Data Sheets must be completed:

ANNEXURE C : DRAWINGS

N/A

SIGNED ON BEHALF OF TENDERER:

FORM A16 RETURNABLE DOCUMENT CHECKLIST

This form has been created as an aid to ensure a tenderer's compliance with the completion of the returnable schedules.

Reference No	Document Description	Tick if completed
Form A1	Authority for signatory	
Form A2	Schedule of work carried out by Tenderer	
Form A3	Proposed key personnel	
Form A4	Schedule of constructional plant	
Form A5	Company Organogram & Business Profile	
Form A6	Schedule of proposed subcontractors	
Form A7	Tenderer's bank details and financial references	
Form A8	Schedule of current commitments	
Form A9	Estimated monthly expenditure	
Form A10	Details of alternative tenders submitted	
Form A11	Proposed amendments and qualifications by Tenderer	
Form A12	Tax Compliance Status	
Form A13	Certificate of insurance cover	
Form A14	Preliminary construction programme	
Form A15	Data Sheets	N/A
Form A16	Returnable document checklist	
Form B1	Proof of registration with Construction Industry Development Board	
Form B2	Form concerning fulfilment of the Construction Regulations, 2014	
Form B3	Record of Addenda of Tender Documents	
Form B4	Letter of Intent to provide a Performance Bond	
Form C1	Compulsory Enterprise Questionnaire	
Form C2	Functionality Table	
Form C3	Preferencing Schedules: Preference points claim form in terms of Preferential Procurement Regulations, 2022 (WCBD 6.1)	
Form C4	Declaration of Interest (WCBD 4)	
Form C5	Certificate of Independent Bid Determination (SBD 9)	
Form C1.1	Form of Offer and Acceptance	
Form C1.2	Contract Data: Tenderer's Selection	
Form C2.2	Bills of Quantities	

SIGNED ON BEHALF OF TENDERER:

FORM B1 PROOF OF REGISTRATION WITH CONSTRUCTION INDUSTRY DEVELOPMENT BOARD

The Tenderer shall provide a printed copy of the Active Contractor's Listing off the CIDB website. (www.cidb.org.za). In the case of a joint venture, a printed copy of the Active Contractor's listing must be provided for each member of the joint venture.

Name of Contractor:

Contractor Grading Designation:

CIDB Contractor Registration Number:

SIGNED ON BEHALF OF THE TENDERER:

FORM B2 FORM CONCERNING FULFILMENT OF THE CONSTRUCTION REGULATIONS, 2014

In terms of Regulation 5(1)(h) of the Construction Regulations, 2014 (hereinafter referred to as the Regulations), promulgated on 7 February 2014 in terms of Section 43 of the Occupational Health and Safety Act, 1993 (Act No 85 of 1993), the Employer shall not appoint a Contractor to perform construction work unless the Contractor can satisfy the Employer that his/her firm has the necessary competencies and resources to carry out the work safely and has allowed adequately in his/her Tender for the due fulfilment of all the applicable requirements of the Act and the Regulations.

- 1 I confirm that I am fully conversant with the Regulations and that my company has (or will acquire/procure) the necessary competencies and resources to timeously, safely and successfully comply with all of the requirements of the Regulations. (Tick)

YES	<input type="checkbox"/>
NO	<input type="checkbox"/>

- 2 Proposed approach to achieve compliance with the Regulations (Tick)

Own resources, competent in terms of the Regulations (refer to 3 below)	<input type="checkbox"/>
Own resources, still to be hired and/or trained (until competency is achieved)	<input type="checkbox"/>
Specialist subcontract resources (competent) - specify:	<input type="checkbox"/>

- 3 Provide details of proposed key persons, competent in terms of the Regulations, who will form part of the Contract team as specified in the Regulations (CVs to be attached):

.....

4 Provide details of proposed training (if any) that will be undergone:

.....
.....
.....
.....
.....
.....
.....

5 Potential key risks identified and measures for addressing risks:

.....
.....
.....
.....
.....
.....

6 I have fully included in my tendered rates and prices (in the appropriate payment items provided in the Schedule of Quantities) for all resources, actions, training and any other costs required for the due fulfilment of the Regulations for the duration of the construction and defects repair period.
(Tick)

YES	
NO	

7 The Tenderer shall attach to this Form evidence that he is registered and in good standing with a compensation insurer who is approved by Department of Labour in terms of section 80 of the Compensation for Injury and Disease Act, 1993 (Act No 130 of 1993)(COID).

The Tenderer is required to disclose, by also attaching documentary evidence to this form, all inspections, investigations and their outcomes conducted by the Department of Labour into the conduct of the Tenderer at any time during the 36 months preceding the date of this Tender.

SIGNATURE OF PERSON(S) AUTHORISED TO SIGN THIS TENDER:

1 ID NO:

2 ID NO:

FORM B3 RECORD OF ADDENDA TO TENDER DOCUMENTS

We confirm that the following communications issued by the Employer before the submission of this Tender offer, amending the Tender Documents, have been taken into account in this Tender offer:

	Date	Title or details
1		
2		
3		
4		
5		
6		
7		
8		
9		
10		

Attach additional pages if more space is required.

Signed: Date:

Name: Position:

SIGNED ON BEHALF OF TENDERER:

FORM B4 LETTER OF INTENT TO PROVIDE A GUARANTEE FOR CONSTRUCTION

It is hereby agreed that a Guarantee for Construction drafted exactly as set out in the attached examples (See Section C1.3: Form of Guarantee) will be provided by the Surety named below:

Name of Surety (Bank or Insurer) _____

Address: _____

Signed: _____

Name: _____

Capacity: _____

On behalf of Tenderer (name of tenderer) _____

Date: _____

CONFIRMED BY Surety's Authorised representative

Signature(s): _____

Name (print): _____

Capacity _____

On behalf of Surety (Bank or Insurer) _____

Date: _____

FORM C1 COMPULSORY ENTERPRISE QUESTIONNAIRE

The following particulars must be furnished. In the case of a joint venture, separate enterprise questionnaires in respect of each partner must be completed and submitted.

Section 1: **Name of enterprise:**.....

Section 2: **VAT registration number, if any:**.....

Section 3: **CIDB registration number, if any:**.....

Section 4: **Particulars of sole proprietors and partners in partnerships**

Name*	Identity number*	Personal income tax number*

*Complete only if sole proprietor or partnership and attach separate page if more than 3 partners.

Section 5: **Particulars of companies and close corporations**

Company registration number:

Close corporation number:

Tax reference number:

Section 6: **Record in the service of the state**

Indicate by marking the relevant boxes with a cross, if any sole proprietor, partner in a partnership or director, manager, principal shareholder or stakeholder in a company or close corporation is currently, or has been within the last 12 months, in the service of any of the following:

<input type="checkbox"/> a member of any municipal council <input type="checkbox"/> a member of any provincial legislature <input type="checkbox"/> a member of the National Assembly or the National Council of Province <input type="checkbox"/> a member of the board of directors of any municipal entity <input type="checkbox"/> an official of any municipality or municipal entity	<input type="checkbox"/> an employee of any provincial department, national or provincial public entity or constitutional institution within the meaning of the Public Finance Management Act, 1999 (Act No 1 of 1999) <input type="checkbox"/> a member of an accounting authority of any national or provincial public entity <input type="checkbox"/> an employee of Parliament or a provincial legislature
--	--

If any of the above boxes are marked, disclose the following:

*

Name of sole proprietor, partner, director, manager, principal shareholder or stakeholder	Name of institution, public office, board or organ of state and position held	Status of service (tick appropriate column)	
		Current	Within last 12 months

*Insert separate page if necessary.

Section 7: Record of spouses, children and parents in the service of the state

Indicate by marking the relevant boxes with a cross, if any spouse, child or parent or a sole proprietor, partner in a partnership or director, manager, principal shareholder or stakeholder in a company or close corporation is currently, or has been within the last 12 months, in the service of any of the following:

<input type="checkbox"/> a member of any municipal council <input type="checkbox"/> a member of any provincial legislature <input type="checkbox"/> a member of the National Assembly or the National Council of Province <input type="checkbox"/> a member of the board of directors of any municipal entity <input type="checkbox"/> an official of any municipality or municipal entity	<input type="checkbox"/> an employee of any provincial department, national or provincial public entity or constitutional institution within the meaning of the Public Finance Management Act, 1999 (Act No 1 of 1999) <input type="checkbox"/> a member of an accounting authority of any national or provincial public entity <input type="checkbox"/> an employee of Parliament or a provincial legislature
--	--

*

Name of spouse, child or parent	Name of institution, public office, board or organ of state and position held	Status of service (tick appropriate column)	
		Current	Within last 12 months

*Insert separate page if necessary.

The undersigned, who warrants that he/she is duly authorised to do so on behalf of the enterprise:

- (i) authorises the Employer to obtain a tax clearance certificate from the South African Revenue Services that my/our tax matters are in order;
- (ii) confirms that neither the name of the enterprise or the name of any partner, manager, director or other person, who wholly or partly exercises, or may exercise, control over the enterprise appears on the Register of Tender Defaulters established in terms of the Prevention and Combating of Corrupt Activities Act, 2004;
- (iii) confirms that no partner, member, director or other person, who wholly or partly exercises, or may exercise, control over the enterprise, has within the last five years been convicted of fraud or corruption;
- (iv) confirms that I/we are not associated, linked or involved with any other tendering entities submitting tender offers and have no other relationship with any of the Tenderers or those responsible for compiling the Scope of Work that could cause or be interpreted as a conflict of interest; and
- (v) confirms that the contents of this questionnaire are within my personal knowledge and are to the best of my belief both true and correct.

Signed: Date:

Name: Position:

Enterprise name:

FORM C2 FUNCTIONALITY TABLE:**FUNCTIONALITY****1 GENERAL DEFINITIONS:**

- 1.1 “**Functionality**” means the measurement according to predetermined norms of a service or commodity designed to be practical and useful, working or operating, taking into account quality, reliability, viability and durability of a service or commodity

The evaluation of the bids will be conducted in the following two stages:

A. Firstly, the assessment of functionality will be done in terms of item 4 below. A bid will be disqualified if it Fails to meet the minimum threshold for functionality as per the bid invitation (**The minimum threshold will be 70% of the 100 points awarded for functionality**)

B. Thereafter, only the qualifying bids are evaluated in terms of the 80/20 or 90/10 preference points systems, where the 80 or 90 points must be used for price only and the 20 or 10 points are used for Broad-Based Black Economic Empowerment (B-BBEE) status level of contribution

2 ADJUDICATION USING A POINT SYSTEM:

- 2.1 “**Functionality**” means the specialist expertise, technical ability and experience that the tenderer for a specific project type.

3 DETERMINATION OF FUNCTIONALITY COMPONENT:

A bid will be disqualified if it Fails to meet the minimum threshold for functionality as per the bid invitation (**The minimum threshold will be 70% of the 100 points awarded for functionality**)

Tenderers will be evaluated in terms of information made available in relation to the following categories.

4	FUNCTIONALITY TABLE	Maximum Points	Tender Document Reference
4.1.	Experience and standing	20	
4.1.1.	Provide a representative list of up to 5 completed projects, including contactable references of project leaders or clients, of similar or greater scope and value (>20kW Installed Solar Capacity) in the last 5 years. (4 points per valid project reference)	20	FORM A2, Pg T2.6
4.2.	Capability	40	
4.2.1.	The contractor must be an electrical company performing electrical work, especially in the field of PV solar. The contractor must preferably be part of SAPVIA and/or SESSA. (5 points for CIPC registration certificate showing the company is an electrical installer, 5 points if the contractor is registered and in good standing at SAPVIA and/or SESSA (provide proof of registration))	10	FORM A5, Pg T2.10
4.2.2.	Provide details of up to 5 similar grid-tied photovoltaic projects, including contactable references of project leaders or clients, with work of a similar nature, design, complexity, standard of minimum 100kW capacity or minimum value of R 3 000 000.00 which you have successfully completed within the last 5 years. (4 points per valid project reference)	20	FORM A2, Pg T2.6
4.2.3.	The company permanently employs an electrician who can perform the wiring of premises according to SANS 10142. Provide their CV and proof of registration with the Electrical Conformance Board of SA (ECB) and the Department of Labour. (5 points for proof of employment & submission of electrician company CV, 5 points if the electrician is registered with the department of labour)	10	FORM A3, Pg T2.7

4.3.	Resources	20	
4.3.1.	Provide an overview of your company structure and business profile (3 points if organogram is provided, 2 points if business profile is provided)	5	FORM A5, Pg T2.10
4.3.2.	Indicate the infrastructure capacity available locally of your company with specific reference to the operational needs of this project from the point of view of fabrication and installation of the major components, quality management and site supervision. (3 points if infrastructure capacity is provided)	3	FORM A5, Pg T2.10
4.3.3.	Provide CV's of the Construction Manager and key personnel to be employed substantially full time on this project and in key supporting roles – provide schedule of work experience and credentials. (4 points if all CV's is provided)	4	FORM A3, Pg T2.7
4.3.4.	Capacity for shop drawings : Indicate whether your company have the capacity to provide drawings (in electronic format) of key installations. (Distribution boards, prefabricated inverter enclosures (kiosks)) (refer to clause 1.23 of the Tender Specification) (3 points if drawings will be provided)	3	Annexure B, Pg 38
4.3.5.	Capacity for electrical usage logging : Indicate whether your company have the capacity to provide electrical usage logging. (refer to clause 1.9 of the Tender Specification) (3 points if electrical usage logging conform with the specification)	3	Annexure B, Pg 12
4.3.6.	Capacity for structural engineering report : Indicate whether your company have the capacity to provide a structural engineering report. Provide details of the structural engineer to issue the report. (refer to clause 1.10 of the Tender Specification) (2 points if details of structural engineer is be provided)	2	Annexure B, Pg 13
4.4.	Materials and Equipment Suppliers	10	
4.4.1.	Preferred Equipment Suppliers : (refer to clause 2 of the Tender Specification) Provide details of suppliers for the following Electrical Equipment: <ul style="list-style-type: none"> ○ LV Panel Switchgear/Componentry (Supplier conform with the specification = 2 points; Non-conformance = 0 points) ○ BESS (Battery Energy Storage System) (Supplier conform with the specification = 2 points; Non-conformance = 0 points) ○ Solar Panels (Supplier conform with the specification = 2 points; Non-conformance = 0 points) ○ Inverters (Supplier conform with the specification = 2 points; Non-conformance = 0 points) ○ Cabling (MV, LV, Instrument, Control, Network, Fire) & LV DBs (Supplier conform with the specification = 2 points; Non-conformance = 0 points) 	2 2 2 2 2	Annexure B, Pg 39-40
4.5.	Approach	10	
4.5.1.	Procurement programme : The attention of tenderers is drawn to the contract period. Provide an indicative procurement programme of your procurement requirements with lead time requirements. (Procurement programme provided = 3 points)	3	FORM A14, Pg T2.19
4.5.2.	Construction programme : The attention of the tenderers is drawn to the dates for completion of construction documentation in the document. Provide an indicative construction programme including the dates for various provisional sums and all completion stages and project phasing. Note that this programme will be annexed to the building contract upon award as a legally binding document. (Construction programme provided = 5 points)	5	FORM A14, Pg T2.19
4.5.3.	Environmental Management : Tenderers are to submit details of their intent to administer and comply with Environmental Management procedures, with reference to the National Environmental Management Act of 2009 and generic environmental specification. (Environmental Management procedures provided = 2 points)	2	Annexure D
TOTAL POINTS FOR FUNCTIONALITY		100	

FORM C3 PREFERENCING SCHEDULES:

WCBD 6.1

PREFERENCE POINTS CLAIM FORM IN TERMS OF THE PREFERENTIAL PROCUREMENT REGULATIONS 2022 AND IN TERMS OF THE WESTERN CAPE GOVERNMENTS INTERIM STRATEGY AS IT RELATES TO PREFERENCE POINTS

This preference form must form part of all bids invited. It contains general information and serves as a claim form for preference points for Broad-Based Black Economic Empowerment (B-BBEE) Status Level of Contribution

NB: BEFORE COMPLETING THIS FORM, BIDDERS (TENDERERS) MUST STUDY THE GENERAL CONDITIONS, DEFINITIONS AND DIRECTIVES APPLICABLE IN RESPECT OF THE TENDER, PREFERENTIAL PROCUREMENT REGULATIONS, 2022 AND THE BROAD BASED BLACK ECONOMIC EMPOWERMENT ACT AND THE CODES OF GOOD PRACTICE

1. DEFINITIONS

- 1.1 **“acceptable tender”** means any tender which, in all respects, complies with the specifications and conditions of tender as set out in the tender document.
- 1.2 **“affidavit”** is a type of verified statement or showing, or in other words, it contains a verification, meaning it is under oath or penalty of perjury, and this serves as evidence to its veracity and is required for court proceedings.
- 1.3 **“all applicable taxes”** includes value-added tax, pay as you earn, income tax, unemployment insurance fund contributions and skills development levies;
- 1.4 **“B-BBEE”** means broad-based black economic empowerment as defined in section 1 of the Broad-Based Black Economic Empowerment Act;
- 1.5 **“B-BBEE status level of contributor”** means the B-BBEE status of an entity in terms of a code of good practice on black economic empowerment issued in terms of section 9(1) of the Broad-Based Black Economic Empowerment Act;
- 1.6 **“bid”** means a written offer on the official bid documents or invitation of price quotations and **“tender”** is the act of bidding /tendering;
- 1.7 **“Code of Good Practice”** means the generic codes or the sector codes as the case may be;
- 1.8 **“consortium or joint venture”** means an association of persons for the purpose of combining their expertise, property, capital, efforts, skill and knowledge in an activity for the execution of a contract;
- 1.9 **“contract”** means the agreement that results from the acceptance of a bid by an organ of state;
- 1.10 **“EME”** is an Exempted Micro Enterprise with an annual total revenue of R10 million or less.
- 1.11 **“Firm price”** means the price that is only subject to adjustments in accordance with the actual increase or decrease resulting from the change, imposition, or abolition of customs or excise duty and any other duty, levy, or tax, which, in terms of the law or regulation, is binding on the contractor and demonstrably has an influence on the price of any supplies, or the rendering costs of any service, for the execution of the contract;
- 1.12 **“Large Enterprise”** is any enterprise with an annual total revenue above R50 million;
- 1.13 **“non-firm prices”** means all prices other than “firm” prices;

- 1.14 **“person”** includes a juristic person;
- 1.15 **“price”** means an amount of money tendered for goods or services, and includes all applicable taxes less all unconditional discounts;
- 1.16 **“proof of B-BBEE status level contributor”** means-
- (a) The B-BBEE status level certificate issued by an authorized body or person;
 - (b) A sworn affidavit as prescribed in terms of the B-BBEE Codes of Good Practice; or
 - (c) Any other requirement prescribed in terms of the Broad- Based Black Economic Empowerment Act.
- 1.17 **QSE** is a Qualifying Small Enterprise with an annual total revenue between R10 million and R50 million;
- 1.18 **“rand value”** means the total estimated value of a contract in Rand, calculated at the time of bid invitation, and includes all applicable taxes;
- 1.19 **“sub-contract”** means the primary contractor’s assigning, leasing, making out work to, or employing, another person to support such primary contractor in the execution of part of a project in terms of the contract.
- 1.20 **“tender”** means a written offer in the form determined by an organ of state in response to an invitation to provide or services through price quotations, competitive tendering process or any other method envisaged in legislation;
- 1.21 **“tender for income-generating contracts”** means a written offer in the form determined by an organ of state in response to an invitation for the origination of income-generating contracts through any method envisaged in legislation that will result in a legal agreement between the organ of state and a third party that produces revenue for the organ of state, and includes, but is not limited to, leasing and disposal of assets and concession contracts, excluding direct sales and disposal of assets through public auctions;
- 1.22 **“the Act”** means the Preferential Procurement Policy Framework Act, 2000 (Act No. 5 of 2000);
- 1.23 **“the Regulations”** means the Preferential Procurement Regulations, 2022;
- 1.24 **“total revenue”** bears the same meaning assigned to this expression in the Codes of Good Practice on Black Economic Empowerment, issued in terms of section 9(1) of the Broad-Based Black Economic Empowerment Act and promulgated in the Government Gazette on 11 October 2013;
- 1.25 **“trust”** means the arrangement through which the property of one person is made over or bequeathed to a trustee to administer such property for the benefit of another person; and
- 1.26 **“trustee”** means any person, including the founder of a trust, to whom property is bequeathed in order for such property to be administered for the benefit of another person.

2. GENERAL CONDITIONS

- 2.1 The following preference point systems are applicable to all bids:
- the 80/20 system for requirements with a Rand value of up to R50 000 000 (all applicable taxes included); and
 - the 90/10 system for requirements with a Rand value above R50 000 000 (all applicable taxes included).
- 2.2 Preference point system for this bid:
- (a) The value of this bid is estimated to not exceed R50 000 000 (all applicable taxes included) and therefore the preference point system shall be applicable.
- 2.3 Preference points for this bid (even in the case of a tender for income-generating contracts) shall be awarded for:

- (a) Price; and
- (b) B-BBEE Status Level of Contribution.

2.4 The maximum points for this bid are allocated as follows:

	POINTS
PRICE	80
B-BBEE STATUS LEVEL OF CONTRIBUTOR	20
Total points for Price and B-BBEE must not exceed	100

2.5 Failure on the part of a bidder to fill in, sign this form and submit in the circumstances prescribed in the Codes of Good Practice either a B-BBEE Verification Certificate issued by a Verification Agency accredited by the South African Accreditation System (SANAS) or an affidavit confirming annual total revenue and level of black ownership together with the bid or an affidavit issued by Companies Intellectual Property Commission, will be interpreted to mean that preference points for B-BBEE status level of contribution are not claimed.

2.6 The organ of state reserves the right to require of a bidder, either before a bid is adjudicated or at any time subsequently, to substantiate any claim in regard to preferences, in any manner required by the organ of state.

3. ADJUDICATION USING A POINT SYSTEM

3.1 Subject to Section 2 (1) (f) of the Preferential Procurement Policy Framework Act, 2000, the **bidder obtaining the highest number of total points** will be awarded the contract.

3.2 A tenderer must submit proof of its B-BBEE status level of contributor in order to claim points for B-BBEE.

3.3 A tenderer failing to submit proof of B-BBEE status level of contributor or is a non-compliant contributor to B-BBEE will not be disqualified but will only score:

- (a) points out of 80 for price; and
- (b) 0 points out of 20 for B-BBEE

3.4 Points scored must be rounded off to the nearest 2 decimal places.

3.5 In the event that two or more bids have scored equal total points, the successful bid must be the one scoring the highest number of preference points for B-BBEE.

3.6 As per section 2 (1) (f) of the Preferential Procurement Policy Framework Act, 2000, the contract may be awarded to a bidder other than the one scoring the highest number of total points based on objective criteria in addition to those contemplated in paragraph (d) and (e) of the Act that justifies the award to another tenderer provided that it has been stipulated upfront in the tendering conditions.

3.7 Should two or more bids be equal in all respects; the award shall be decided by the drawing of lots.

4. FORMULAE FOR PROCUREMENT OF GOODS AND SERVICES

4.1 POINTS AWARDED FOR PRICE

4.1.1 THE 80/20 OR 90/10 PREFERENCE POINT SYSTEM

A maximum of 80 or 90 points is allocated for price on the following basis:

$$P_s = 80 \left(1 - \frac{P_t - P_{\min}}{P_{\min}} \right) \quad \text{or} \quad P_s = 90 \left(1 - \frac{P_t - P_{\min}}{P_{\min}} \right)$$

Where

P_s = Points scored for price of bid under consideration

P_t = Price of tender under consideration

P_{\min} = Price of lowest acceptable tender

5. FORMULAE FOR DISPOSAL OR LEASING OF STATE ASSETS AND INCOME GENERATING PROCUREMENT

5.1 POINTS AWARDED FOR PRICE

A maximum of 80 or 90 points is allocated for price on the following basis:

$$P_s = 80 \left(1 + \frac{P_t - P_{\max}}{P_{\max}} \right) \quad \text{or} \quad P_s = 90 \left(1 + \frac{P_t - P_{\max}}{P_{\max}} \right)$$

Where

P_s = Points scored for price of tender under consideration

P_t = Price of tender under consideration

P_{\max} = Price of highest acceptable tender

6. POINTS AWARDED FOR B-BBEE STATUS LEVEL OF CONTRIBUTION

- 6.1 In terms of WCG interim strategy, preference points must be awarded to a bidder for attaining the B-BBEE status level of contribution in accordance with the table below:

B-BBEE Status Level of Contributor	Number of points (90/10 system)	Number of points (80/20 system)
1	10	20
2	9	18
3	6	14
4	5	12
5	4	8
6	3	6
7	2	4
8	1	2
Non-compliant contributor	0	0

- 6.2 An **EME** must submit a valid, originally certified affidavit confirming annual turnover and level of black ownership or an affidavit issued by Companies Intellectual Property Commission
- 6.3 A **QSE that is less than 51 per cent (50% or less) black owned** must be verified in terms of the QSE scorecard issued via Government Gazette and submit a valid, original or a legible certified copy of a B-BBEE Verification Certificate issued by SANAS.
- 6.4 A **QSE that is at least 51 per cent black owned (51% or higher)** must submit a valid, originally certified affidavit confirming turnover and level of black ownership as well as declare its empowering status or an affidavit issued by Companies Intellectual Property Commission.
- 6.5 A **large enterprise** must submit a valid, original or originally certified copy of a B-BBEE Verification Certificate issued by a verification agency accredited by SANAS.
- 6.6 A trust, consortium or joint venture, will qualify for points for their B-BBEE status level as a legal entity, provided that the entity submits their B-BBEE status level certificate.
- 6.7 A trust, consortium or joint venture (including unincorporated consortia and joint ventures) must submit a consolidated B-BBEE status level verification certificate for every separate tender.
- 6.8 Tertiary institutions and public entities will be required to submit their B-BBEE status level certificates in terms of the specialized scorecard contained in the B-BBEE Codes of Good Practice.

7. BID DECLARATION

- 7.1 Bidders who claim points in respect of B-BBEE Status Level of Contribution must complete the following:

8. B-BBEE STATUS LEVEL OF CONTRIBUTION CLAIMED IN TERMS OF PARAGRAPH 6

- 8.1 B-BBEE Status Level of Contribution..... =(maximum of 20 points)

(Points claimed in respect of paragraph 7.1 must be in accordance with the table reflected in paragraph 6.1 and must be substantiated by means of a B-BBEE certificate issued by a Verification Agency accredited

by SANAS or an affidavit confirming annual total revenue and level of black ownership in terms of the relevant sector code applicable to the tender.

9. SUB-CONTRACTING

9.1 Will any portion of the contract be sub-contracted? **YES/NO** (delete which is not applicable)

9.1.1 If yes, indicate:

- (i) what percentage of the contract will be subcontracted?%
- (ii) the name of the sub-contractor?
- (iii) the B-BBEE status level of the sub-contractor?
- (iv) whether the sub-contractor is an EME or QSE? **YES/NO** (delete which is not applicable)

9.1.2 Sub-contracting relates to a **particular** contract and if sub-contracting is applicable, the bidder to state in their response to a particular RFQ that a portion of that contract will be sub- contracted.

10. DECLARATION WITH REGARD TO COMPANY/FIRM

10.1 Name of company/ entity:

10.2 VAT registration number:

10.3 Company Registration number:

10.4 TYPE OF COMPANY/ FIRM

- Partnership/ Joint Venture/ Consortium
- One-person business/ sole propriety
- Close corporation
- Public Company
- Personal Liability Company
- (Pty) Limited
- Non-Profit Company
- State Owned Company

[SELECT APPLICABLE ONE]

10.5 I/we, the undersigned, who is / are duly authorised to do so on behalf of the company/firm, certify that the points claimed, based on the B-BBEE status level of contribution indicated in paragraph 7 above, qualifies the company/ firm for the preference(s) shown and I/we acknowledge that:

- (a) The Western Cape Government reserves the right to audit the B-BBEE status claim submitted by the bidder.
- (b) As set out in Section 130 of the B-BBEE Act as amended, any misrepresentation constitutes a criminal offence. A person commits an offence if that person knowingly:
 - (i) misrepresents or attempts to misrepresent the B-BBEE status of an enterprise;
 - (ii) provides false information or misrepresents information to a B-BBEE Verification Professional in order to secure a particular B-BBEE status or any benefit associated with compliance to the B-BBEE Act;
 - (iii) provides false information or misrepresents information relevant to assessing the B-BBEE status of an enterprise to any organ of state or public entity; or

- (iv) engages in a fronting practice.
- (c) If a B-BBEE verification professional or any procurement officer or other official of an organ of state or public entity becomes aware of the commission of, or any attempt to commit any offence referred to in paragraph 10.5 (a) above will be reported to an appropriate law enforcement agency for investigation.
- (d) Any person convicted of an offence by a court is liable in the case of contravention of 10.5 (b) to a fine or to imprisonment for a period not exceeding 10 years or to both a fine and such imprisonment or, if the convicted person is not a natural person to a fine not exceeding 10 per cent of its annual turnover.
- (e) The purchaser may, if it becomes aware that a bidder may have obtained its B-BBEE status level of contribution on a fraudulent basis, investigate the matter. Should the investigation warrant a restriction be imposed, this will be referred to the National Treasury for investigation, processing and imposing the restriction on the National Treasury's List of Restricted Suppliers. The bidder or contractor, its shareholders and directors, or only the shareholders and directors who acted on a fraudulent basis, may be restricted from obtaining business from any organ of state for a period not exceeding 10 years, after the audi alteram partem (hear the other side) rule has been applied.
- (f) The purchaser may, in addition to any other remedy it may have –
 - (i) disqualify the person from the bidding process;
 - (ii) recover costs, losses or damages it has incurred or suffered as a result of that person's conduct;
 - (iii) cancel the contract and claim any damages which it has suffered as a result of having to make less favourable arrangements due to such cancellation; and
 - (iv) forward the matter for criminal prosecution.
- (g) The information furnished is true and correct.
- (h) The preference points claimed are in accordance with the General Conditions as indicated in paragraph 2 of this form.

SIGNATURE(S) OF THE BIDDER(S):

DATE:

ADDRESS:

.....

WITNESSES:

1.

2.

FORM C4 DECLARATION OF INTEREST

WCBD 4

PROVINCIAL GOVERNMENT WESTERN CAPE**DECLARATION OF INTERESTS, BIDDERS PAST SCM PRACTICES AND INDEPENDENT BID DETERMINATION**

1. To give effect to the requirements of the Western Cape Provincial Treasury Instructions, 2019: Supply Chain Management (Goods and Services), Public Finance Management Act (PFMA) Supply Chain Management (SCM) Instruction No. 3 of 2021/2022 - SBD 4 Declaration of Interest, Section 4 (1)(b)(iii) of the Competition Act No. 89 of 1998 as amended together with its associated regulations, the Prevention and Combating of Corrupt Activities Act No 12 of 2004 and regulations pertaining to the tender defaulters register, Paragraph 16A9 of the National Treasury Regulations and/or any other applicable legislation.
2. Any person (natural or juristic) may make an offer or offers in terms of this invitation to bid. In line with the principles of transparency, accountability, impartiality, and ethics as enshrined in the Constitution of the Republic of South Africa and further expressed in various pieces of legislation, it is required for the bidder to make this declaration in respect of the details required hereunder.
3. All prospective bidders intending to do business with the Institution must be registered on the Central Supplier Database (CSD) and the Western Cape Supplier Evidence Bank (WCSEB) if they wish to do business with the Western Cape Government (WCG) via the electronic Procurement Solution (ePS).
4. The status of enterprises and persons listed on the National Treasury's Register for Tender Defaulters will be housed on the ePS. Institutions may not under any circumstances procure from enterprises and persons listed on the Database of Tender Defaulters.
5. The status of suppliers listed on the National Treasury's Database of Restricted Suppliers will be housed on the ePS; however, it remains incumbent on institutions to check the National Treasury Database of Restricted Suppliers before the conclusion of any procurement process. For suppliers listed as restricted, institutions must apply due diligence and risk assessment before deciding to proceed with procurement from any such supplier.
6. **Definitions**

"bid" means a bidder's response to an institution's invitation to participate in a procurement process which may include a bid, price quotation or proposal;

"Bid rigging (or collusive bidding)" occurs when businesses, that would otherwise be expected to compete, secretly conspire to raise prices or lower the quality of goods and / or services for purchasers who wish to acquire goods and/or services through a bidding process. Bid rigging is, therefore, an agreement between competitors;

"business interest" means –

- (a) a right or entitlement to share in profits, revenue or assets of an entity;
- (b) a real or personal right in property;
- (c) a right to remuneration or any other private gain or benefit, or
- (d) includes any interest contemplated in paragraphs (a), (b) or (c) acquired through an intermediary and any potential interest in terms of any of those paragraphs;

"Consortium or Joint Venture" means an association of persons for the purpose of combining their expertise, property, capital, efforts, skill and knowledge in an activity for the execution of a contract;

“Controlling interest” means, the power, by one person or a group of persons holding the majority of the equity of an enterprise, alternatively, the person/s having the deciding vote or power to influence or to direct the course and decisions of the enterprise;

“Corruption”- General offences of corruption are defined in the Combating of Corrupt Activities Act, 2004 (Act No 12 of 2004) as:

Any person who directly or indirectly –

- (a) accepts or agrees or offers to accept an! gratification from any other person, whether for the benefit of himself or herself or for the benefit of another person; or
- (b) gives or agrees or offers to give to any other person any gratification, whether for the benefit of that other person or for the benefit of another person., in order to act personally or by influencing another person so to act, in a manner—
 - (i) that amounts to the-
 - (aa) illegal. dishonest. unauthorised. incomplete. or biased: or
 - (bb) misuse or selling of information or material acquired in the course of the exercise, carrying out or performance of any powers, duties or functions arising out of a constitutional, statutory, contractual or any other legal obligation:
 - (ii) that amounts to-
 - (aa) the abuse of a position of authority;
 - (bb) a breach of trust; or
 - (cc) the violation of a legal duty or a set of rules;
 - (iii) designed to achieve an unjustified result; or
 - (iv) that amounts to any other unauthorised or improper inducement to do or 45 not to do anything. of the, is guilty of the offence of corruption.

“CSD” means the Central Supplier Database maintained by National Treasury;

“employee”, in relation to –

- (a) a department, means a person contemplated in section 8 of the Public Service Act, 1994 but excludes a person appointed in terms of section 12A of that Act; and
- (b) a public entity, means a person employed by the public entity;

“entity” means any –

- (a) association of persons, whether or not incorporated or registered in terms of any law, including a company, corporation, trust, partnership, close corporation, joint venture or consortium; or
- (b) sole proprietorship;

“entity conducting business with the Institution” means an entity that contracts or applies or tenders for the sale, lease or supply of goods or services to the Province;

“Family member” means a person’s –

- (a) spouse; or

- (b) child, parent, brother, sister, whether such a relationship results from birth, marriage or adoption or some other legal arrangement (as the case may be);

“intermediary” means a person through whom an interest is acquired, and includes a representative or agent or any other person who has been granted authority to act on behalf of another person;

“Institution” means –

a provincial department or provincial public entity listed in Schedule 3C of the Act;

“Provincial Government Western Cape (PGWC)” means

- (a) the Institution of the Western Cape, and
- (b) a provincial public entity;

“RWOEE” means –

Remunerative Work Outside of the Employee’s Employment

“spouse” means a person’s –

- (a) partner in marriage or civil union according to legislation;
- (b) partner in a customary union according to indigenous law; or
- (c) partner with whom he or she cohabits and who is publicly acknowledged by the person as his or her life partner or permanent companion.

7. Regulation 13(c) of the Public Service Regulations (PSR) 2016, effective 1 February 2017, prohibits any employee from conducting business with an organ of state, or holding a directorship in a public or private company doing business with an organ of state unless the employee is a director (in an official capacity) of a company listed in schedules 2 and 3 of the Public Finance Management Act.

- (a) Therefore, by 31 January 2017 all employees who are conducting business with an organ of state should either have:
 - (i) resigned as an employee of the government institution or;
 - (ii) cease conducting business with an organ of state or;
 - (iii) resign as a director/shareholder/owner/member of an entity that conducts business with an organ of state.

8. Any legal person, or their family members, may make an offer or offers in terms of this invitation to bid. In view of potential conflict of interest, in the event that the resulting bid, or part thereof, be awarded to family members of persons employed by an organ of state, it is required that the bidder or his/her authorised representative declare his/her position in relation to the evaluating/adjudicating authority where the bidder is employed by the Institution.

9. The bid of any bidder may be disregarded if that bidder or any of its directors abused the institution’s supply chain management system; committed fraud or any other improper conduct in relation to such system; disclosure is found not to be true and complete; or failed to perform on any previous contract.

10. Section 4(1)(b)(iii) of the Competition Act No. 89 of 1998, as amended, prohibits an agreement between, or concerted practice by firms, or a decision by an association of firms, if it is between parties in a horizontal relationship and if it involves collusive bidding (or bid rigging). Collusive bidding is a per se prohibition meaning that it cannot be justified under any grounds.

C2. TABLE C

Complete the below table to the maximum of the last 5 contracts.

NAME OF CONTRACTOR	PROVINCIAL DEPARTMENT OR PROVINCIAL ENTITY	TYPE OF SERVICES OR COMMODITY	CONTRACT/ ORDER NUMBER	PERIOD OF CONTRACT	VALUE OF CONTRACT	
C3. Is the entity or its principals listed on the National Database as companies or persons prohibited from doing business with the public sector?					NO	YES
C4. Is the entity or its principals listed on the National Treasury Register for Tender Defaulters in terms of section 29 of the Prevention and Combating of Corrupt Activities Act (No. 12 of 2004)?					NO	YES
<i>(To access this Register enter the National Treasury's website, www.treasury.gov.za, click on the icon "Register for Tender Defaulters" or submit your written request for a hard copy of the Register to facsimile number (012) 326 5445.)</i>						
C5. If yes to C3 or C4, were you informed in writing about the listing on the database of restricted suppliers or Register for Tender Defaulters by National Treasury?				NO	YES	N/A
C6. Was the entity or persons listed in Table A convicted for fraud or corruption during the past five years in a court of law (including a court outside the Republic of South Africa)?					NO	YES
C7. Was any contract between the bidder and any organ of state terminated during the past five years on account of failure to perform on or comply with the contract?					NO	YES

SECTION D: DULY AUTHORISED REPRESENTATIVE TO DEPOSE TO AFFIDAVIT

This form must be signed by a duly authorised representative of the entity in the presence of a commissioner of oaths.

- I, hereby swear/affirm;
- i. that the information disclosed above is true and accurate;
 - ii. that I have read understand the content of the document;
 - iii. that I have arrived at the accompanying bid independently from, and without consultation, communication, agreement or arrangement with any competitor.
 - iv. that the entity undertakes to independently arrive at any offer at any time to the Institution without any consultation, communication, agreement or arrangement with any competitor. In addition, that there will be no consultations, communications, agreements or arrangements with any competitor regarding the quality, quantity, specification, prices, including methods, factors or formulas used to calculate prices, market allocation, the intention or decision to submit or not to submit the bid, bidding with the intention not to win the bid and conditions or delivery particulars of the products or services to which this bid invitation relates;
 - v. that the entity or its representative are aware of and undertakes not to disclose the terms of any bid, formal or informal, directly or indirectly, to any competitor, prior to the date and time of the official bid opening or of the awarding of the contract; and
 - vi. that there have been no consultations, communications, agreements or arrangements made with any official of the procuring institution in relation to this procurement process prior to and during the bidding process except to provide clarification on the bid submitted where so required by the institution; and that my entity was not involved in the drafting of the specifications or terms of reference for this bid.

.....
DULY AUTHORISED REPRESENTATIVE'S SIGNATURE

I certify that before administering the oath/affirmation I asked the deponent the following questions and wrote down his/her answers in his/her presence:

- 1.1 Do you know and understand the contents of the declaration? ANSWER:
- 1.2 Do you have any objection to taking the prescribed oath? ANSWER:
- 1.3 Do you consider the prescribed oath to be binding on your conscience? ANSWER:.....
- 1.4 Do you want to make an affirmation? ANSWER:
- 2. I certify that the deponent has acknowledged that he/she knows and understands the contents of this declaration, which was sworn to/affirmed and the deponent's signature/thumbprint/mark was place thereon in my presence.

..... SIGNATURE FULL
NAMES Commissioner of Oaths

Designation (rank)..... ex officio: Republic of South Africa

Date:..... Place

Business Address:
.....
.....

FORM C5: CERTIFICATE OF INDEPENDENT BID DETERMINATION

SBD 9

CERTIFICATE OF INDEPENDENT BID DETERMINATION

- 1 This Standard Bidding Document (SBD) must form part of all bids¹ invited.
- 2 Section 4 (1) (b) (iii) of the Competition Act No. 89 of 1998, as amended, prohibits an agreement between, or concerted practice by, firms, or a decision by an association of firms, if it is between parties in a horizontal relationship and if it involves collusive bidding (or bid rigging).² Collusive bidding is a *pe se* prohibition meaning that it cannot be justified under any grounds.
- 3 Treasury Regulation 16A9 prescribes that accounting officers and accounting authorities must take all reasonable steps to prevent abuse of the supply chain management system and authorizes accounting officers and accounting authorities to:
 - a. disregard the bid of any bidder if that bidder, or any of its directors have abused the institution's supply chain management system and or committed fraud or any other improper conduct in relation to such system.
 - b. cancel a contract awarded to a supplier of goods and services if the supplier committed any corrupt or fraudulent act during the bidding process or the execution of that contract.
- 4 This SBD serves as a certificate of declaration that would be used by institutions to ensure that, when bids are considered, reasonable steps are taken to prevent any form of bid-rigging.
- 5 In order to give effect to the above, the attached Certificate of Bid Determination (SBD 9) must be completed and submitted with the bid:

¹ Includes price quotations, advertised competitive bids, limited bids and proposals.

² Bid rigging (or collusive bidding) occurs when businesses, that would otherwise be expected to compete, secretly conspire to raise prices or lower the quality of goods and / or services for purchasers who wish to acquire goods and / or services through a bidding process. Bid rigging is, therefore, an agreement between competitors not to compete.

CERTIFICATE OF INDEPENDENT BID DETERMINATION

I, the undersigned, in submitting the accompanying bid:

(Bid Number and Description)

in response to the invitation for the bid made by:

(Name of Institution)

do hereby make the following statements that I certify to be true and complete in every respect:

I certify, on behalf of: _____ that:
(Name of Bidder)

1. I have read and I understand the contents of this Certificate;
2. I understand that the accompanying bid will be disqualified if this Certificate is found not to be true and complete in every respect;
3. I am authorized by the bidder to sign this Certificate, and to submit the accompanying bid, on behalf of the bidder;
4. Each person whose signature appears on the accompanying bid has been authorized by the bidder to determine the terms of, and to sign the bid, on behalf of the bidder;
5. For the purposes of this Certificate and the accompanying bid, I understand that the word "competitor" shall include any individual or organization, other than the bidder, whether or not affiliated with the bidder, who:
 - (a) has been requested to submit a bid in response to this bid invitation;
 - (b) could potentially submit a bid in response to this bid invitation, based on their qualifications, abilities or experience; and
 - (c) provides the same goods and services as the bidder and/or is in the same line of business as the bidder

6. The bidder has arrived at the accompanying bid independently from, and without consultation, communication, agreement or arrangement with any competitor. However communication between partners in a joint venture or consortium³ will not be construed as collusive bidding.
7. In particular, without limiting the generality of paragraphs 6 above, there has been no consultation, communication, agreement or arrangement with any competitor regarding:
 - (a) prices;
 - (b) geographical area where product or service will be rendered (market allocation)
 - (c) methods, factors or formulas used to calculate prices;
 - (d) the intention or decision to submit or not to submit, a bid;
 - (e) the submission of a bid which does not meet the specifications and conditions of the bid;or
 - (f) bidding with the intention not to win the bid.
8. In addition, there have been no consultations, communications, agreements or arrangements with any competitor regarding the quality, quantity, specifications and conditions or delivery particulars of the products or services to which this bid invitation relates.
9. The terms of the accompanying bid have not been, and will not be, disclosed by the bidder, directly or indirectly, to any competitor, prior to the date and time of the official bid opening or of the awarding of the contract.

³ Joint venture or Consortium means an association of persons for the purpose of combining their expertise, property, capital, efforts, skill and knowledge in an activity for the execution of a contract.

10. I am aware that, in addition and without prejudice to any other remedy provided to combat any restrictive practices related to bids and contracts, bids that are suspicious will be reported to the Competition Commission for investigation and possible imposition of administrative penalties in terms of section 59 of the Competition Act No 89 of 1998 and or may be reported to the National Prosecuting Authority (NPA) for criminal investigation and or may be restricted from conducting business with the public sector for a period not exceeding ten (10) years in terms of the Prevention and Combating of Corrupt Activities Act No 12 of 2004 or any other applicable legislation.

.....
Signature

.....
Date

.....
Position

.....
Name of Bidder

WESTERN CAPE NATURE CONSERVATION BOARD

TENDER NO. **WCNCB 04/07/2026**

FOR **VROLIJKHEID (PV) SOLAR SYSTEM at Vrolijkheid Nature Reserve, Breede Valley**

THE CONTRACT

PART C1	AGREEMENT AND CONTRACT DATA.....	C1.1 – C1.25
PART C2	PRICING DATA	C2.1 – C2.4
PART C3	SCOPE OF WORK	C3.1 – C3.2
PART C4	SITE INFORMATION.....	C4.1 – C4.5

WESTERN CAPE NATURE CONSERVATION BOARD

TENDER NO. **WCNCB 04/07/2026**

FOR **VROLIJKHEID (PV) SOLAR SYSTEM at Vrolijkheid Nature Reserve, Breede Valley**

PART C1 AGREEMENTS AND CONTRACT DATA

C1.1	FORM OF OFFER AND ACCEPTANCE.....	C1.2 – C1.6
C1.2	CONTRACT DATA	C1.7 – C1.18
C1.3	GUARANTEE FOR CONSTRUCTION (PRO FORMA).....	C1.19 – C1.21
C1.4	AGREEMENT IN TERMS OF THE OCCUPATIONAL HEALTH AND SAFETY ACT, 1993 (ACT NO 85 OF 1993).....	C1.22 – C1.25

WESTERN CAPE NATURE CONSERVATION BOARD

TENDER NO. **WCNCB 04/07/2026**

FOR **VROLIJKHEID (PV) SOLAR SYSTEM at Vrolijkheid Nature Reserve, Breede Valley**

C1.1 FORM OF OFFER AND ACCEPTANCE (AGREEMENT)

OFFER

The Employer, identified in the Acceptance signature block, has solicited offers to enter into a Contract in respect of the following works:

..... **AT**

The Tenderer, identified in the Offer signature block below, has examined the documents listed in the Tender Data and addenda thereto as listed in the Tender Schedules, and by submitting this Offer has accepted the Conditions of Tender.

By the representative of the Tenderer, deemed to be duly authorised, signing this part of this Form of Offer and Acceptance, the Tenderer offers to perform all of the obligations and liabilities of the Contractor under the Contract including compliance with all its terms and conditions according to their true intent and meaning for an amount to be determined in accordance with the Conditions of Contract identified in the Contract Data.

THE OFFERED TOTAL OF THE PRICES INCLUSIVE OF VALUE-ADDED TAX IS

.....
..... rand [in words]; R..... [in figures],

This Offer may be accepted by the Employer by signing the Acceptance part of this Form of Offer and Acceptance and returning one copy of this document to the Tenderer before the end of the period of validity stated in the Tender Data, whereupon the Tenderer becomes the party named as the Contractor in the Conditions of Contract identified in the Contract Data.

Signature(s)

Name(s)

Capacity

[Name and address of organisation]

Name and signature of witness

Date _____

CIDB Registration number

ACCEPTANCE

By signing this part of this Form of Offer and Acceptance, the Employer identified below accepts the Tenderer's Offer. In consideration thereof, the Employer shall pay the Contractor the amount due in accordance with the Conditions of Contract identified in the Contract Data. Acceptance of the Tenderer's Offer shall form an agreement between the Employer and the Tenderer upon the terms and conditions contained in this Agreement and in the Contract that is the subject of this Agreement.

The terms of the Contract are contained in

- Part C1 Agreements and Contract Data [which includes this Agreement]
- Part C2 Pricing Data
- Part C3 Scope of Work
- Part C4 Site Information

and drawings and documents or parts thereof, which may be incorporated by reference into Parts C1 to C4 above.

Deviations from and amendments to the documents listed in the Tender Data and any Addenda thereto listed in the Tender Schedules, as well as any changes to the terms of the Offer agreed by the Tenderer and the Employer during this process of offer and acceptance, are contained in the Schedule of Deviations attached to and forming part of this Agreement. No amendments to or deviations from the said documents are valid unless contained in this Schedule, which must be duly signed by the authorised representative(s) of both parties.

The Tenderer shall within two weeks after receiving a completed copy of this Agreement, including the Schedule of Deviations (if any), contact the Employer's agent (whose details are given in the Contract Data) to arrange the delivery of any bonds, guarantees, proof of insurance and any other documentation to be provided in terms of the Conditions of Contract identified in the Contract Data at, or just after, the date this Agreement comes into effect. Failure to fulfil any of these obligations in accordance with those terms shall constitute a repudiation of this Agreement.

Notwithstanding anything contained herein, this Agreement comes into effect on the date when the Tenderer receives one fully completed original copy of this document, including the Schedule of Deviations (if any). Unless the Tenderer (now Contractor) within five working days of the date of such receipt notifies the Employer in writing of any reason why he cannot accept the contents of this Agreement, this Agreement shall constitute a binding Contract between the parties.

Signature(s)

Name(s)

Capacity

.....

.....

.....

.....

[Name and address of organisation]

Name and signature of witness

Date

.....

SCHEDULE OF DEVIATIONS

Notes:

1. The extent of deviations from the Tender Documents issued by the Employer prior to the Tender closing date is limited to those permitted in terms of the Conditions of Tender.
2. A Tenderer's covering letter shall not be included in the final Contract Document. Should any matter in such letter, which constitutes a deviation as aforesaid, become the subject of agreements reached during the process of offer and acceptance, the outcome of such agreement shall be recorded here.
3. Any other matter arising from the process of offer and acceptance either as a confirmation, clarification or change to the Tender Documents and which is agreed by the Parties becomes an obligation of the Contract and shall also be recorded here.
4. Any change or addition to the Tender Documents arising from the above agreements and recorded here, shall also be incorporated into the final draft of the Contract.

1 Subject

Details

2 Subject

Details

3 Subject

Details

4 Subject

Details

5 Subject

Details

6 Subject

Details

By the duly authorised representatives signing this Schedule of Deviations, the Employer and the Tenderer agree to and accept the foregoing Schedule of Deviations as the only deviations from and amendments to the documents listed in the Tender Data and Addenda thereto as listed in the Tender Schedules, as well as any confirmation, clarification or change to the terms of the offer agreed by the Tenderer and the Employer during this process of offer and acceptance.

It is expressly agreed that no other matter whether in writing, oral communication or implied during the period between the issue of the Tender Documents and the receipt by the Tenderer of a completed signed copy of this Agreement shall have any meaning or effect in the Contract between the parties arising from this Agreement.

FOR THE TENDERER:

Signature(s)

Name(s)

Capacity

.....
[Name and address of organisation]

Name and signature of witness

Date

FOR THE EMPLOYER:

Signature(s)

Name(s)

Capacity

.....
[Name and address of organisation]

Name and signature of witness

Date

CONFIRMATION OF RECEIPT

The Tenderer (now Contractor), identified in the Offer part of this Agreement, hereby confirms receipt from the Employer, identified in the Acceptance part of this Agreement, of one fully completed original copy of this Agreement, including the Schedule of Deviations (if any) today:

the [day]

of [month]

20..... [year]

at [place]

For the Contractor:

.....
Signature

.....
Name

.....
Capacity

Signature and name of witness:

.....
Signature

.....
Name

WESTERN CAPE NATURE CONSERVATION BOARD

TENDER NO. **WCNCB 04/07/2026**

FOR **VROLIJKHEID (PV) SOLAR SYSTEM at Vrolijkheid Nature Reserve, Breede Valley**

C1.2 CONTRACT DATA

PART 1: DATA PROVIDED BY THE EMPLOYER

CONDITIONS OF CONTRACT

The *JBCC Minor Works Agreement : Contract Data, Edition 5.2, 2018*, published by the Joint Building Contracts Committee NPC, is applicable to this Contract and is obtainable from www.asaqs.co.za.

A PROJECT INFORMATION

A 1.0 Works [1.1]

Project Name	VROLIJKHEID (PV) SOLAR SYSTEM
Reference Number	CT0479
Works description	Supply and install a new photovoltaic solar system at Vrolijkheid Nature Reserve including the following: 2 x PowerHub 120 storage units with enclosures, ground mounted PV array with fencing, modification of existing DB's, all reticulation cabling and trenching, water connections, electrical usage logging and structural engineering certification of PV support structures.

A 2.0 Site [1.1]

Erf / stand number	Vrolijkheid Nature Reserve
Township / Suburb	Vrolijkheid Nature Reserve
Site address	Vrolijkheid Nature Reserve, Breede Valley (33°55'03.8"S, 19°52'39.0"E). Approximately 15km south of Robertson on the Langverwagten Road towards McGregor.
Local authority	Langeberg Local Municipality

A 3.0 Employer [1.1]

Name	Western Cape Nature Conservation Board		
Legal entity of above	Western Cape Nature Conservation Board	Contact person	Ramese Mathews
Business registration number	N/A	Telephone number	087 087 3175
VAT/GST number	N/A	Mobile number	082 303 7462
Country	SOUTH AFRICA	E-mail	rmathews@capenature.co.za
Postal address	3rd Floor, PGWC Shared Services Centre, Cnr Bosduif & Volstruis Streets Bridgetown		
		Postal code	7764
Physical address	3rd Floor, PGWC Shared Services Centre, Cnr Bosduif & Volstruis Streets Bridgetown		
		Postal code	7764

A 4.0 Principal agent [1.1; 5.1]

Name	Bührmann Engineering (Pty) Ltd		
Legal entity of above	Private Company	Contact person	Braam Human
Practice number	1286	Telephone number	021 930 4934
		Mobile number	
Country	SOUTH AFRICA	E-mail	braam@buhrmannce.co.z
Postal address	Unit 25, Muirfield House, Midpark Business Village, 2 Greens Close Parow		
		Postal code	7500
Physical address	Unit 25, Muirfield House, Midpark Business Village, 2 Greens Close Parow		
		Postal code	7500

A 5.0 Agent [1.1; 5.2]	Discipline	Electrical Engineer
-------------------------------	------------	----------------------------

Name	Bühmann Engineering (Pty) Ltd		
Legal entity of above	Private Company	Contact person	Braam Human
Practice number	1286	Telephone number	021 930 4934
		Mobile number	
Country	SOUTH AFRICA	E-mail	braam@buhmannce.co.za
Postal address	Unit 25, Muirfield House, Midpark Business Village, 2 Greens Close		
	Parow	Postal code	7500
Physical address	Unit 25, Muirfield House, Midpark Business Village, 2 Greens Close		
	Parow	Postal code	7500

A 6.0 Agent [1.1; 5.2]	Discipline	Health & Safety Consultant
-------------------------------	------------	---------------------------------------

Name			
Legal entity of above		Contact person	
Practice number		Telephone number	
		Mobile number	
Country		E-mail	
Postal address			
		Postal code	
Physical address			
		Postal code	

A 7.0 Agent [1.1; 5.2]	Discipline	N/A
-------------------------------	------------	------------

Name			
Legal entity of above		Contact person	
Practice number		Telephone number	
		Mobile number	
Country		E-mail	
Postal address			
		Postal code	
Physical address			
		Postal code	

A 8.0 Agent [1.1; 5.2]	Discipline	N/A
-------------------------------	------------	------------

Name			
Legal entity of above		Contact person	
Practice number		Telephone number	
		Mobile number	
Country		E-mail	
Postal address			
		Postal code	
Physical address			
		Postal code	

B 5.0 Employer's agents [5.0]

Authority is delegated to the following agents to issue contract instructions and perform duties for specific aspects of the works [5.2]
Electrical Engineer

Principal agents and agents interest or involvement in the works other than a professional interest [5.3]
N/A

B 6.0 Insurances [8.0]

Insurances by employer			Amount including tax	Deductible amount including tax
Contract works insurance:				
	New works [8.2.1] (contract sum or amount)		N/A	N/A
or	Works with alterations and additions [8.2.1] (reinstatement value of existing structures with or including new works)		R 20 000 000.00	R 10 000.00
	Direct contractors [13.0] where applicable, to be included in the contract works insurance		N/A	N/A
	Free issue [10.1.12] where applicable, to be included in the contract works insurance		N/A	N/A
	Escalation, professional fees and reinstatement costs of not included above			
Total of the above contract works insurance amount			R 20 000 000.00	R 10 000.00
Supplementary insurance [8.2.2]			N/A	N/A
Public liability insurance [8.2.3]			R 20 000 000.00	R 10 000 000.00
Removal of lateral support insurance [8.2.4]			N/A	N/A
Other insurances [8.2.5]			N/A	N/A
Yes/no?	Yes	If yes, description 1	R 20 000 000.00	R 10 000 000.00
SASRIA				
Yes/no?	N/A	If yes, description 2		

B 7.0 Obligations of the employer [10.1]

Existing premises will be in use and occupied [10.1.3]		Yes/no?	Yes
If yes, description	-		
Restriction of working hours [10.1.3]		Yes/no?	Yes
If yes, description	Work normal business hours 8:00 to 17:00 on Working Days		
Natural features and known services to be preserved by the contractor [10.1.4]		Yes/no?	Yes
If yes, description	All existing services to stay in tact		
Restrictions to the site or areas that the contractor may not occupy [10.1.5]		Yes/no?	Yes
If yes, description	Contractor may only occupy areas and use access routes as indicated in green on drawing No. CT0479-EL-LAY-0001 and may not venture into any of the adjacent reserve, fields, accomodation, buildings, etc.		
Supply of free issue [10.1.12]		Yes/no?	No
If yes, description			

B 8.0 Direct contractors [13.0]

Extent of work [10.1.13]	N/A
Extent of work [10.1.13]	N/A
Extent of work [10.1.13]	N/A
Extent of work [10.1.13]	N/A
Extent of work [10.1.13]	N/A

B 9.0 Possession of site [10.1.6] practical completion[15.0;17.0] and penalties [18.0]

Practical completion for the works as a whole	Intended date of possession of the site [10.1.6]	Period for inspection by the principal agent [15.3]	Date for practical completion [15.1.1]	Penalty [18.1]
	Date	working days	Date	Penalty amount per calendar day
	TBC	2	TBC	R 5 500.00

Criteria to achieve practical completion not covered in the definition of practical completion
<p>The requirements for practical completion are:</p> <ul style="list-style-type: none"> •The inverters and panels must work in conjunction with each other. It must be demonstrated that the system functions correctly under normal operating conditions. •All DBs must have a valid COC •The 12V DC systems must be tested and confirmed to be fully operational •All campsite lighting must be serviced and repaired to ensure full functionality •The security gate must be installed at the entrance to the DB room, and the new locking mechanism must be installed on the buildings entrance gate. The offline CCTV camera must record footage and store it in the connected DVR •Fire detection equipment must be installed at the campsite ablutions facility •All electrical installations must adhere to the requirements of SANS 10142-1

B 10.0 Payment [19.0]

Date of month for issue of regular payment certificates [19.2]	26th
---	-------------

B 11.0 Dispute resolution [22.0]

Adjudication [22.5.1] Name of nominating body	Association of Arbitrators
Applicable rules for adjudication [22.5.2]	As recommended by the Association of Arbitrators
Arbitration [22.6.4] Name of nominating body	Association of Arbitrators
Applicable rules for arbitration [22.6.5]	Arbitration Act 42 of 1965

B 12.0 JBCC® General Preliminaries - selections

Provisional bills of quantities [P2.2]	Yes/no?	Yes	
Availability of construction information [P2.3]	Yes/no?	Yes	
Previous work - dimensional accuracy - details [P3.1]	-		
Previous work - defects - details [P3.2]	-		
Inspection of adjoining properties - details [P3.3]	-		
Handover of site in stages - specific requirements [P4.1]	N/A		
Enclosure of the works - specific requirements [P4.2]	-		
Geotechnical and other investigations - specific requirements [P4.3]	-		
Existing premises occupied - details [P4.5]	-		
Services - known - specific requirements [P4.6]	All existing services to stay in tact		
Water [P8.1]	By contractor	Yes/no?	No
	By employer	Yes/no?	No
	By employer - metered	Yes/no?	Yes
Electricity [P8.2]	By contractor	Yes/no?	Yes
	By employer	Yes/no?	No
	By employer - metered	Yes/no?	No
Ablution and welfare facilities [P8.3]	By contractor	Yes/no?	Yes
	By employer	Yes/no?	No
Communication facilities - specific requirements [P8.4]	Email, Cellphone, Telephone, Facsimile		
Protection of the works - specific requirements [P11.1]	-		

Protection / isolation of existing works and works occupied in sections - specific requirements [P11.2]	No
Disturbance - specific requirements [P11.5]	-
Environmental disturbance - specific requirements [P11.6]	The contractor shall submit an Environmental Management Plan for approval by the principal agent and execute works in accordance wit the management plan for the whole durations of the works

B.13.0 Changes made to the JBCC® documentation

Reference may be made to other documents forming part of this agreement
<p>Clause 16.1 The defects liability period for the works shall commence on the calendar day following the date of practical completion and end at midnight (00:00) one (1) year from the date of practical completion [CD] or when work on the list for completion has been satisfactorily completed [16.4], whichever is the later</p>

C TENDER CLOSING

Tender closing date	04 August 2026	Time	11:00
Tender submission address	CapeNature Head Office, 3rd Floor, PGWC Shared Services Centre, Cnr Bosduif & Volstruis Streets, Bridgetown, 7764		
Tender may be submitted by e-mail	yes/no ?	Yes	E-mail tenders@capenature.co.za

D TENDERER'S SELECTIONS

D 1.0 Securities [9.0]

Guarantee for construction: Select Option A or B

Option A	Guarantee for construction (variable) by contractor [9.1.1]
----------	---

Option B	Payment reduction [9.1.2]
----------	----------------------------------

Guarantee for payment by employer [9.2]	Amount	N/A
---	--------	------------

Advance payment, subject to a guarantee for advance payment [9.4]	Amount	N/A
--	--------	------------

D 2.0 Contractor's annual holiday periods during the construction period

Year 1 contractor's annual holiday period	start date	N/A	end date	N/A
Year 2 contractor's annual holiday period	start date	N/A	end date	N/A
Year 3 contractor's annual holiday period	start date	N/A	end date	N/A

D 3.0 Payment of preliminaries [19.0]

Select Option A or B Where the **contractor** does not select an option, Option A shall apply

Where the total amount of **preliminaries** is not identified (in a lump sum contract) it shall be taken as 7.5% (seven and a half per cent) of the **contract sum**, excluding contingency sums, and any provision for contract price adjustment (cost fluctuation)

Option A	Assessed by the principal agent , an amount prorated to the value of the works executed in the same ratio as the amount of the preliminaries to the contract sum which contract sum shall exclude the amount of preliminaries . Contingency sum(s) and any provision for contract price adjustment (cost fluctuations) shall be excluded for the calculation of the aforesaid ratio
----------	--

Option B	An amount agreed by the principal agent and the contractor in terms of the bills of quantities or the priced document to identify an initial establishment charge, a time based charge and a final disestablishment charge. Payment of the time base charge shall be adjusted from time to time as may be necessary to take into account the progress of the works
----------	--

D 4.0 Adjustment of preliminaries [20.6.3]

Select Option A or B Where the **contractor** does not select an option, Option A shall apply

The amount of **preliminaries** shall be adjusted to take account of the effect of changes in time and/or value on **preliminaries**. Such adjustment shall be based on the particulars provided by the **contractor** for this purpose in terms of Options A or B, shall preclude any further adjustment of the amount of **preliminaries** and shall apply notwithstanding the actual employment of resources by the **contractor** in the execution of the **works**

For the adjustment of **preliminaries** both the **contract sum** and the **contract value** shall exclude the amount of **preliminaries**, contingency sum(s) and any provision for contract price adjustment (cost fluctuations)

Where the total amount of **preliminaries** is not identified (in a lump sum contract) it shall be taken as 7.5% (seven and a half per cent) of the **contract sum**, excluding contingency sums, and any provision for contract price adjustment (cost fluctuation)

<p>Option A</p>	<p>The preliminaries shall be adjusted in accordance with an allocation of preliminaries amounts to be provided by the contractor within fifteen (15) working days of the date of acceptance of the tender as follows:</p> <ul style="list-style-type: none"> - An amount which shall not be varied; - An amount varied in proportion to the contract value as compared to the contract sum; - An amount varied in proportion to the number of calendar days extension to the date of practical completion to which the contractor is entitled with an adjustment of the contract value as compared to the number of calendar days in the initial construction period <p>Where the above mentioned information is not provided the following allocation of preliminaries amounts shall apply:</p> <ul style="list-style-type: none"> - Ten per cent (10%) shall not be varied - Fifteen per cent (15%) shall be varied in proportion to the contract value as compared to the contract sum - Seventy five per cent (75%) shall be varied in proportion to the number of calendar days extension to the date of practical completion to which the contractor is entitled with an adjustment of the contract value as compared to the number of calendar days in the initial construction period
<p>Option B</p>	<p>The preliminaries shall be adjusted in accordance with a detailed breakdown of preliminaries amounts for the works to be provided by the contractor within fifteen (15) working days of possession of the site. Such breakdown shall inter alia include administrative and supervisory staff charges and charges for the use of construction equipment, all in terms of the programme.</p> <p>The adjustment of preliminaries shall be based on the number of calendar days extension to the date of practical completion to which the contractor is entitled with an adjustment of the contract value as compared to the number of calendar days in the initial construction period taking into account the resources planned for the period of construction during which the delay occurred (not for the period added tot the initial or extended date for the practical completion)</p> <p>Where the contractor does not provide the detailed breakdown of preliminaries within the period stated, Option A shall apply</p>

E FORM OF TENDER

E 1.0 Tenderer's details

Name			
Legal entity of above		Contact person	
Business registration number		Telephone number	
VAT/GST number		Mobile number	
Country		E-mail	
Postal address			
		Postal code	
Physical address			
		Postal code	

E 2.0 Acceptance of tender conditions

By submission of this tender to the **employer** the tenderer offers and agrees to execute and complete the **works** and to remedy any **defects** in conformity with the specification for the tender amount stated

The tender shall remain in full legal force for three (3) months from the closing date of the tender. The tenderer accepts liability for loss or damages that may be suffered by the employer should the tender validity period not be honoured

The lowest or any tender will not necessarily be accepted by the **employer** nor will reasons be given for such a decision

E 3.0 Tender amount compilation

	Amount	
Tenderer's work excluding tax	R	-
Tax	15 %	R -
Total tender amount including tax	R	-
Total tender amount including tax , in words		

Signature	Tenderer who by signature hereto warrants authority	Place		
Name		Capacity	Date	

Signature	Witness	Place		
Name		Date		

E 4.0 Tender qualifications

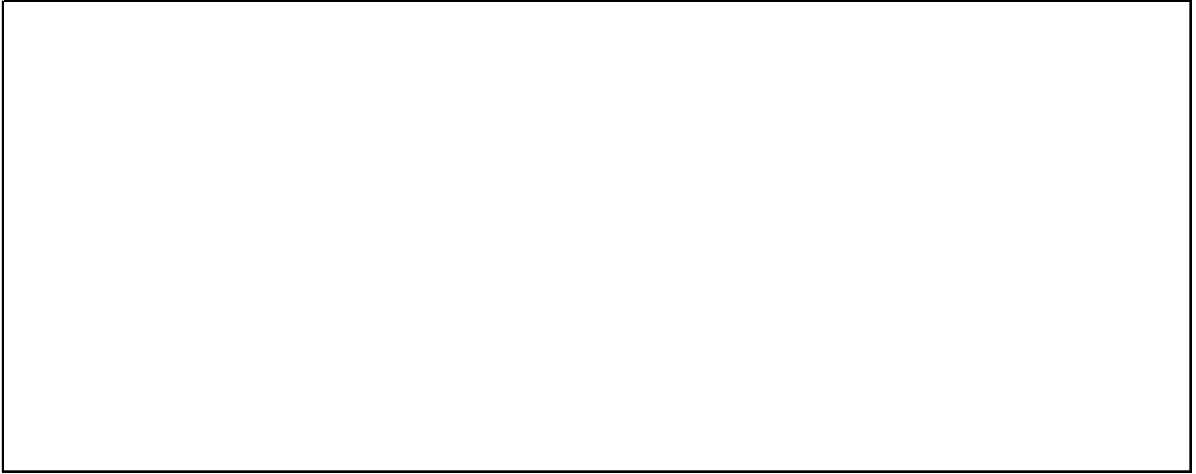

WESTERN CAPE NATURE CONSERVATION BOARD

TENDER NO. **WCNCB 04/07/2026**

FOR **VROLIJKHEID (PV) SOLAR SYSTEM at Vrolijkheid Nature Reserve, Breede Valley**

C1.3 PERFORMANCE GUARANTEE (PRO FORMA)



MWA Guarantee for Construction

For use with the JBCC® Minor Works edition/ date

GUARANTOR DETAILS AND DEFINITIONS

Guarantor:

Physical Address:

Guarantor's signatory 1: Capacity

Guarantor's signatory 2: Capacity

Employer:

Contactor:

Principal Agent:

Works:

Site:

Contract Sum: Accepted amount inclusive of tax Currency

... amount in words:

Guaranteed Sum: The maximum aggregate amount Currency

Guarantee Expiry Date:

AGREEMENT DETAILS

Principal Agent issues: JBCC® format Interim Payment Certificates, the Final Payment Certificate, the Certificate of Practical Completion and the Certificate of Final Completion

1.0 The Guarantor's liability shall be limited to the diminishing amounts of the Guaranteed Sum as follows:

GUARANTOR'S LIABILITY	PERIOD OF LIABILITY
<p>1.1.1 Maximum Guaranteed Sum (not exceeding 6.0% of the contract sum) in the amount of:</p> <p style="text-align: center;"><input style="width: 120px;" type="text"/></p> <p>Amount in words: <input style="width: 360px;" type="text"/></p>	<p>From and including the date of issue of this MWA Guarantee for Construction and up to and including the date of Certificate of Practical Completion</p>
<p>1.1.2 Reducing to the Guaranteed Sum (not exceeding 4.0% of the contract sum) in the amount of:</p> <p style="text-align: center;"><input style="width: 120px;" type="text"/></p> <p>Amount in words: <input style="width: 360px;" type="text"/></p>	<p>From and including the day after the date of the Certificate of Practical Completion and up to and including the date of the Certificate of Final Completion</p>
<p>1.1.3 Reducing to the Guaranteed Sum (not exceeding 2.0% of the contract sum) in the amount of:</p> <p style="text-align: center;"><input style="width: 120px;" type="text"/></p>	<p>From and including the day after the date of the Certificate of Final Completion and up to and including the date of issue of the Final Payment Certificate where payment is due to the Contractor, whereupon this MWA Guarantee for Construction shall expire. Where the Final Payment Certificate reflects payment due to the Employer, this MWA Guarantee for Construction shall expire on payment of the full amount</p>

Amount in words:

- 2.0 The Guarantor's liability limits set out in clauses 1.1 to 1.3 shall apply in respect of any claim received by the Guarantor during the guarantee validity period.
- 3.0 The Guarantor acknowledges that:
- 3.1 Any reference in this MWA Guarantee to the Agreement is made for the purpose of convenience and shall not be construed as any intention whatsoever to create an accessory obligation or any intention whatsoever to create a suretyship.
- 3.2 Its obligation under this MWA Guarantee for Construction is restricted to the payment of money.
- 3.3 Reference to a Certificate of Practical Completion or to a Certificate of Final Completion shall mean such certificate as issued by the Principal Agent.
- 4.0 Subject to the Guarantor's maximum liability referred to in 1.0, the Guarantor hereby undertakes to pay the Employer the sum certified upon receipt of the documents identified in 4.1 to 4.3:
- 4.1 A copy of a first written demand notice issued by the Employer to the Contractor stating that payment of a sum certified by the Principal Agent in an Interim or Final Payment Certificate has not been made in terms of the Agreement and failing such payment within seven (7) calendar days, the Employer intends to call upon the Guarantor to make payment in terms of 4.2;
- 4.2 A written demand notice issued by the Employer to the Guarantor at the Guarantor's Physical Address with a copy to the Contractor stating that a period of seven (7) calendar days has elapsed since the date of issue of the first written demand notice in terms of 4.1 and that the sum certified has not been paid to date. The Employer herewith calls up this MWA Guarantee for Construction and demands payment of the sum certified from the Guarantor; and
- 4.3 A copy of the applicable payment certificate which entitles the Employer to receive payment in terms of the Agreement of the sum certified in 4.0.
- 5.0 Subject to the Guarantor's maximum liability referred to in 1.0, the Guarantor undertakes to pay the Employer the Guaranteed Sum or the full outstanding balance upon receipt of a first written demand from the Employer to the Guarantor at the Guarantor's Physical Address calling up this MWA Guarantee for Construction stating that:
- 5.1 The Agreement has been terminated due to the Contractor's default and that the MWA Guarantee for Construction is called up in terms of 5.0. The demand notice shall enclose a copy of the notice of termination, or
- 5.2 A provisional sequestration or liquidation court order has been granted against the Contractor and that the MWA Guarantee for Construction is called up in terms of 5.0. The demand notice shall enclose a copy of the court order.
- 6.0 The aggregate amount of payments to be made by the Guarantor in terms of 4.0 and 5.0 shall not exceed the Guarantor's maximum liability in terms of 1.0.
- 7.0 Where the Guarantor is a registered insurer and has made payment in terms of 5.0, the Employer shall within one hundred and twenty (120) calendar days of receipt of payment submit an expense account to the Guarantor showing how all monies received in terms of this MWA Guarantee for Construction have been expended or will be expended, and shall refund to the Guarantor any surplus amount. All monies refunded to the Guarantor in terms of this MWA Guarantee for Construction shall bear interest at the prime overdraft rate of the Employer's bank compounded monthly and calculated from the date payment by the Guarantor to the Employer until the date of refund.
- 8.0 Payment by the Guarantor in terms of 4.0 or 5.0 shall be made within seven (7) calendar days upon receipt of the first written demand notice to the Guarantor.
- 9.0 The Employer shall have the absolute right to arrange its affairs with the Contractor in any manner which the Employer deems fit and the Guarantor shall not have the right to claim his release from this MWA Guarantee for Construction on account of any conduct alleged to be prejudicial to the Guarantor.
- 10.0 The Guarantor chooses the Physical Address stated above for all notices and correspondences in relation to the Guarantee.
- 11.0 This MWA Guarantee for Construction is neither negotiable nor transferable and shall expire in terms of either 1.1.3, or payment in full of the Guaranteed Sum or on the Guarantee expiry date, whichever is the earlier, whereafter no claims will be considered by the Guarantor. The original of this MWA Guarantee for Construction shall be returned to the Guarantor after it has expired.

- 12.0 This MWA Guarantee for Construction, with the required demand notices in terms of 4.0 or 5.0, shall be regarded as a liquid document for the purpose of obtaining a court order
- 13.0 Where this MWA Guarantee for Construction is issued in the Republic of South Africa this MWA Guarantee shall be governed by the laws of the Republic of South Africa. A competent court in the Republic of South Africa shall have sole jurisdiction in terms of this MWA Guarantee. Where this MWA Guarantee is issued outside the Republic of South Africa, the laws of the guarantor who issued this MWA Guarantee shall prevail. A competent court, in the jurisdiction in which the guarantor is domicile shall prevail.

Signed at:

Date:

Guarantor's Signatory 1:

Guarantor's Signatory 2:

Witness:

Witness:

Guarantor's seal or stamp

WESTERN CAPE NATURE CONSERVATION BOARD

TENDER NO. **WCNCB 04/07/2026**

FOR **VROLIJKHEID (PV) SOLAR SYSTEM at Vrolijkheid Nature Reserve, Breede Valley**

C1.4 AGREEMENT IN TERMS OF THE OCCUPATIONAL HEALTH AND SAFETY ACT, 1993 (ACT NO 85 OF 1993)

THIS AGREEMENT made at
on this the day of in the year
between [hereinafter called "the Employer"] of the one
part, herein represented by
in his capacity as
and
[hereinafter called "the Mandatary"] of the other part, herein represented by
.....
in his capacity as

WHEREAS the Employer is desirous that certain works be constructed, viz

WESTERN CAPE NATURE CONSERVATION BOARD

and has accepted a Tender by the Mandatary for the construction, completion and maintenance of such Works and whereas the Employer and the Mandatary have agreed to certain arrangements and procedures to be followed in order to ensure compliance by the Mandatary with the provisions of the Occupational Health and Safety Act, 1993 (Act 85 of 1993);

NOW THEREFORE THIS AGREEMENT WITNESSETH AS FOLLOWS:

- 1 The Mandatary shall execute the work in accordance with the Contract Documents pertaining to this Contract.
- 2 This Agreement shall hold good from the contract date, which shall be the date of a written acceptance by the employer or principal agent of the contractor's offer and continue to be in force and affect until:
 - (a) the date of the Certificate of Final Completion issued in terms of Clause 16.0 (JBCC MWA 5.2), or
 - (b) the date of termination of the agreement in terms of Clause 21.0 (JBCC MWA 5.2).

- 3 The Mandatary declares himself to be conversant with the following:
- (a) All the requirements, regulations and standards of the Occupational Health and Safety Act, 1993 (Act No 85 of 1993), hereinafter referred to as "The Act", together with its amendments and with special reference to the following sections of The Act:
 - (i) Section 8 : General duties of employers to their employees;
 - (ii) Section 9 : General duties of employers and self-employed persons to persons other than employees;
 - (iii) Section 37 : Acts or omissions by employees or mandataries, and
 - (iv) Subsection 37(2) relating to the purpose and meaning of this Agreement.
 - (b) The procedures and safety rules of the Employer as pertaining to the Mandatary and to all his subcontractors.
- 4 In addition to the requirements of Clause 2.0 (JBCC MWA 5.1) and all relevant requirements of the agreement, the Mandatary agrees to execute all the Works forming part of this agreement and to operate and utilise all machinery, plant and equipment in accordance with the Act.
- 5 The Mandatary is responsible for the compliance with the Act by all his subcontractors, whether or not selected and/or approved by the Employer.
- 6 ***The Mandatary warrants that all his and his subcontractors' workmen are covered in terms of the Compensation for Occupational Injuries and Diseases Act, 1993 which cover shall remain in force whilst any such workmen are present on site. A letter of good standing from the Compensation Commissioner to this effect must be produced to the Employer upon signature of the agreement.***
- 7 The Mandatary undertakes to ensure that he and/or subcontractors and/or their respective employers will at all times comply with the following conditions:
- (a) The Mandatary shall assume the responsibility in terms of Section 16.1 of the Occupational Health and Safety Act. The Mandatary shall not delegate any duty in terms of Section 16.2 of this Act without the prior written approval of the Employer. If the Mandatary obtains such approval and delegates any duty in terms of Section 16.2 a copy of such written delegation shall immediately be forwarded to the Employer.
 - (b) All incidents referred to in the Occupational Health and Safety Act shall be reported by the Mandatary to the Department of Labour as well as to the Employer. The Employer will further be provided with copies of all written documentation relating to any incident.
 - (c) The Employer hereby obtains an interest in the issue of any formal inquiry conducted in terms of Section 32 of the Occupational Health and Safety Act into any incident involving the Mandatary and/or his employees and/or his subcontractors.

CERTIFICATE OF AUTHORITY FOR SIGNATORY TO AGREEMENT IN TERMS OF OCCUPATIONAL HEALTH AND SAFETY ACT, 1993 (ACT NO 85 OF 1993)

The signatory for the company that is the Contractor in terms of the above-mentioned Contract and the Mandatary in terms of the above-mentioned Act shall confirm his or her authority thereto by attaching to this page a duly signed and dated copy of the relevant resolution of the Board of Directors.

An example is given below:

"By resolution of the Board of Directors passed at a meeting held on 20.....,

Mr/Ms whose signature

appears below, has been duly authorised to sign the AGREEMENT in terms of THE OCCUPATIONAL

HEALTH AND SAFETY ACT, 1993 (ACT NO 85 OF 1993) on behalf of

.....

SIGNED ON BEHALF OF THE COMPANY :

IN HIS/HER CAPACITY AS :

DATE :

SIGNATURE OF SIGNATORY :

WITNESS: 1. 2.

NAME (IN CAPITALS): 1. 2.

WESTERN CAPE NATURE CONSERVATION BOARD

TENDER NO. **WCNCB 04/07/2026**

FOR **VROLIJKHEID (PV) SOLAR SYSTEM at Vrolijkheid Nature Reserve, Breede Valley**

PART C2 PRICING DATA

C2.1 PRICING INSTRUCTIONS.....C2.2 - C2.3

C2.2 BILL OF QUANTITIES.....C2.4

WESTERN CAPE NATURE CONSERVATION BOARD

TENDER NO. **WCNCB 04/07/2026**FOR **VROLIJKHEID (PV) SOLAR SYSTEM at Vrolijkheid Nature Reserve, Breede Valley****C2.1 PRICING INSTRUCTIONS**

1 The Conditions of Contract are the JBCC Minor Works Agreement inclusive of the Contract Data Addenda CD (Edition 5.2 of May 2018) and JBCC General Preliminaries (Edition 6.2 of May 2018) prepared by the Joint Building Contracts Committee Inc. The said JBCC Minor Works Agreement inclusive of the Contract Data Addenda CD shall be deemed to be incorporated herein.

2 The Bill comprises items covering the Contractor's profit and costs of general liabilities and of the construction of Temporary and Permanent Works.

Although the Tenderer is at liberty to insert a rate of his own choosing for each item in the Bill, he should note the fact that the Contractor is entitled, under various circumstances, to payment for additional work carried out and that the principal agent's is obliged to base his assessment of the rates to be paid for such additional work on the rates the Contractor inserted in the Bill.

3 The items in these **bills of quantities** utilise abbreviated descriptions. It is the intention that the abbreviated descriptions be fully described when read with the applicable measuring system and the relevant preambles and/or specifications. However, should the full intent and meaning of any description not be clear, the **contractor** shall, before submission of his tender, call for a written directive from the **principal agent**, failing which it shall be assumed that the **contractor** has allowed in his pricing for materials and workmanship in terms of international best practice. No consideration will be given to any claim by the Contractor submitted on such a basis. The Bill has been drawn up in accordance with the latest issue of Standard System of Measuring Building Work Seventh Edition.

4 Unless stated to the contrary, items are measured net in accordance with the drawings without any allowance having been made for waste.

5 The contractor is to allow opposite each item for all costs in connection therewith. All prices to include, unless otherwise stated, for all materials, fabrication, conveyance and delivery, unloading, storing, unpacking, hoisting, labour, setting, fitting and fixing in position, cutting and waste (except where to be measured in accordance with the standard system of measurement), patterns, models and templates, plant, temporary works, returning of packaging, duties, taxes (other than Value Added Tax), imposts, establishment charges, overheads, profit and all other obligations arising out of this agreement. Value Added Tax (VAT) is to be separately stated on the summary page of these bills of quantities.

6 An amount or rate shall be entered against each item in the Bill of Quantities, whether or not quantities are stated. Items left unpriced will be deemed to be covered in prices against other items throughout these **bills of quantities** and no claim for any extras arising out of the **contractor's** omission to price any item will be entertained.

The Tenderer shall also fill in a rate against the items where the words "rate only" appear in the amount column. Although no work is foreseen under these items and no quantities are consequently given in the quantity column, the tendered rates shall apply should work under these items actually be required.

Should the Tenderer group a number of items together and tender one sum for such group of items, the single tendered sum shall apply to that group of items and not to each individual item, or should he indicate against any item that full compensation for such item has been included in another item, the rate for the item included in another item shall be deemed to be nil.

The tendered rates, prices and sums shall, subject only to the provisions of the Conditions of Contract, remain valid irrespective of any change in the quantities during the execution of the Contract.

7 The quantities of work as measured and accepted and certified for payment in accordance with the Conditions of Contract, and not the quantities stated in the Bill of Quantities, will be used to determine payments to the Contractor. The validity of the Contract shall in no way be affected by differences between the quantities in the Bill of Quantities and the quantities certified for payment.

Ordering of materials are not to be based on the Bill of Quantities, but only on information issued for construction purposes.

8 For the purposes of this Bill of Quantities, the following words shall have the meanings hereby assigned to them:

Unit	:	The unit of measurement for each item of work as defined in the Standardized, Project or Particular Specifications
Quantity	:	The number of units of work for each item
Rate	:	The payment per unit of work at which the Tenderer tenders to do the work
Amount	:	The quantity of an item multiplied by the tendered rate of the (same) item
Sum	:	An amount tendered for an item, the extent of which is described in the Bill of Quantities, the Specifications or elsewhere, but of which the quantity of work is not measured in units

9 The units of measurement indicated in the Bill of Quantities are metric units. The following abbreviations may appear in the Bill of Quantities:

mm	=	millimetre
m	=	metre
km	=	kilometre
km-pass	=	kilometre-pass
m ²	=	square metre
m ² -pass	=	square metre-pass
ha	=	hectare
m ³	=	cubic metre
m ³ -km	=	cubic metre-kilometre
kW	=	kilowatt
kN	=	kilonewton
kg	=	kilogram
t	=	ton (1 000 kg)
%	=	per cent
MN	=	meganewton
MN-m	=	meganewton-metre
PC Sum	=	prime cost sum
Prov Sum	=	provisional sum

WESTERN CAPE NATURE CONSERVATION BOARD

TENDER NO. **WCNCB 04/07/2026**

FOR **VROLIJKHEID (PV) SOLAR SYSTEM at Vrolijkheid Nature Reserve, Breede Valley**

C2.2 BILLS OF QUANTITIES

SUMMARY	2
BILL NO 1 : PRELIMINARIES & GENERALS.....	4
BILL NO 2 : LOW-VOLTAGE DISTRIBUTION BOARDS.....	6
BILL NO 3 : CABLEWAYS	7
BILL NO 4 : LOW-VOLTAGE RETICULATION.....	8
BILL NO 5 : LIGHTNING PROTECTION & EARTHING	10
BILL NO 6 : PV SOLAR	11
BILL NO 7 : SURVEYS	13

WESTERN CAPE NATURE CONSERVATION BOARD

TENDER NO. **WCNCB 04/07/2026**

FOR **VROLIJKHEID (PV) SOLAR SYSTEM at Vrolijkheid Nature Reserve, Breede Valley**

PART C3 SCOPE OF WORK

C3.1 DESCRIPTION OF WORK	C3.2
C3.1.1 Employer's objectives	C3.2
C3.1.2 Works Description	C3.2
C3.1.3 Location of the Works	C3.2
C3.2 ENVIRONMENTAL SPECIFICATION	C3.2
C3.3 ELECTRICAL SPECIFICATIONS.....	C3.2

C3.1 DESCRIPTION OF THE WORK

C3.1.1 EMPLOYER'S OBJECTIVES

The Western Cape Nature Conservation Board trading as Cape Nature is a government entity responsible for managing and maintaining 31 nature reserve complexes comprising 112 nature reserves, of which 106 are terrestrial and six are marine protected areas, totalling 828 506 hectares in the Western Cape Province of South Africa. Cape Nature offers a variety of eco-tourism products at 25 of its nature reserves.

As custodian of the province's natural environment, Cape Nature is tasked with nature conservation and awareness, preserving biodiversity, and providing facilities for education, research and is mandated to generate revenue from ecotourism products and experiences.

100% of all revenue generated at Cape Nature is ploughed directly into conservation projects within the Western Cape.

C3.1.2 WORKS DESCRIPTION

The scope of the electrical project includes the installation of a photovoltaic (PV) solar generation and battery backup system at Vrolijkheid Nature Reserve. (33°55'03.8"S, 19°52'39.0"E).

The installation consists of the following: 2 x PowerHub 120 storage units with enclosures, ground mounted PV array with fencing, modification of existing DB's, all reticulation cabling and trenching, water connections, electrical usage logging and structural engineering certification of PV support structures.

This description of the Works is not necessarily complete and shall not limit the work to be carried out by the Contractor under this Contract.

Approximate quantities of each type of work are given in the Bill of Quantities.

C3.1.3 LOCATION OF THE WORKS

Vrolijkheid Nature Reserve, Breede Valley (33°55'03.8"S, 19°52'39.0"E). Approximately 15km south of Robertson on the Langverwagten Road towards McGregor. (Note : An alternative route of ± 65km might be required via Bonnievale if the Reitz Street bridge in Robertson is still closed)

C3.2 ENVIRONMENTAL SPECIFICATION

Refer to Annexure D for Environmental Specification

C3.3 ELECTRICAL SPECIFICATION

Refer to Annexure B for tender specification

WESTERN CAPE NATURE CONSERVATION BOARD

TENDER NO. **WCNCB 04/07/2026**

FOR **VROLIJKHEID (PV) SOLAR SYSTEM at Vrolijkheid Nature Reserve, Breede Valley**

PART C4 SITE INFORMATION

C4.1 ANNEXURES

C4.1.1 ANNEXURE A : BILL OF QUANTITIES.....	C4.2
C4.1.2 ANNEXURE B : TENDER SPECIFICATION	C4.3
C4.1.3 ANNEXURE C : DRAWINGS.....	C4.4
C4.1.3.1 DWG No. CT0479-EL-LAY-0001-R0 : Site Overall Electrical Layout	
C4.1.3.2 DWG No. CT0479-EL-SLD-0001-R0 : Site Overall Single Line Diagram	
C4.1.3.3 DWG No. CT0479-EL-GAR-0001-R0 : Minisub General Arrangement 3D	
C4.1.3.4 DWG No. CT0479-EL-GAR-0002-R0 : PV Solar General Arrangement	
C4.1.3.5 DWG No. CT0479-EL-LAY-0002-R0 : PV Solar Array Layout	
C4.1.3.6 DWG No. CT0479-EL-LAY-0003-R0 : Typical Minisub General Layout	
C4.1.3.7 DWG No. CT0479-EL-LST-0001-R0 : PV Solar Module Stringing Designation	
C4.1.3.8 DWG No. CT0479-EL-LST-0002-R0 : Cable List	
C4.1.4 ANNEXURE D : ENVIRONMENTAL SPECIFICATION.....	C4.5

C4.2

ANNEXURE A
BILLS OF QUANTITIES



Project Name
VROLIJKHEID SOLAR

Project Number
CT0479

Document Title
ELECTRICAL BILL OF QUANTITIES

Document Number
CT0479-EL-BOQ-0001-R0

0	29 May 26	Issued For Tender	P Fourie	B Human
Rev	Date	Description	Prepared	Approved
Document Control				
Consulting Engineer			Client	
<p>Unit 25, Muirfield House, Midpark Business Village, 2 Greens Close, Parow, 7500, South Africa t +27(0)21 930 4934 m +27(0)84 440 9273 info@buhrmannce.co.za www.buhrmannce.co.za</p>			<p>Cape Nature Conservation Board, PGWC Shared Services Centre, corner Bosduif and Volstruis streets, Bridgetown, Gatesville, 7766</p>	



VROLIJKHEID SOLAR
ELECTRICAL BILL OF QUANTITIES
CT0479-EL-BOQ-0001-R0



Bill No	Summary - Description	Cost		Total
		Supply	Install	

Item	Unforeseen Items and Labour Rates	Hourly Rates		
		Normal	After Hours	Sundays
A	Project Manager			
B	Construction Manager			
C	Technician / Artisan			
D	Semi-Skilled Labour			
E	Unskilled Labour			
F	Percentage Mark-up for Unforeseen Items (below R10 000)			20%
G	Percentage Mark-up for Unforeseen Items (R10 000 - R100 000)			15%
H	Percentage Mark-up for Unforeseen Items (R100 000 and above)			13%



VROLIJKHEID SOLAR
ELECTRICAL BILL OF QUANTITIES
CT0479-EL-BOQ-0001-R0



No	Description	Specification	Unit	Qty.	Rate		Cost		Total
					Supply	Install	Supply	Install	
1	Preliminaries & General						R -	R -	R -
1,1	<i>Electrical (P&G)</i>						R -	R -	R -
1,1,1	Preliminary and general cost allowed (P & G) shall include all overhead, supervision, project management & administration, stationary, etc. cost.		sum	1	R -	R -	R -	R -	R -
1,1,2	Subsistence and travel allowances for personnel. This includes airfare, car rental & accommodation.		sum	1	R -	R -	R -	R -	R -
1,1,3	Allowance for Health and Safety Requirements. This includes cost for the compilation of health and safety files, inductions, etc.		sum	1	R -	R -	R -	R -	R -
1,1,4	Contractor's site camp, temporary buildings, ablution and latrine facilities, access, water and power supply, guarding & protection and local transport of personnel and plant to site, including for subsequent removal of all structures and leaving site in condition as specified.		sum	1	R -	R -	R -	R -	R -
1,1,5	Comply with all laws and statutory requirements.		sum	1	R -	R -	R -	R -	R -
1,1,6	Total price for insurance of the works (including riot and political unrest risks)		sum	1	R -	R -	R -	R -	R -
1,1,7	Surety Bond and stamps for Contract.		sum	1	R -	R -	R -	R -	R -
1,1,8	Provide first aid equipment and medical supplies for use at site.		sum	1	R -	R -	R -	R -	R -
1,1,9	Allow for any expenses, which may occur due to unfavourable climatic conditions.		sum	1	R -	R -	R -	R -	R -



VROLIJKHEID SOLAR
ELECTRICAL BILL OF QUANTITIES
CT0479-EL-BOQ-0001-R0



No	Description	Specification	Unit	Qty.	Rate		Cost		Total		
					Supply	Install	Supply	Install			
1,1,10	Total price for all General liabilities and other items in the opinion of the Tenderer not adequately covered in the document but essential for the satisfactory completion of the contract (Details to be supplied).		sum	1	R	-	R	-	R	-	
1,1,11	The Tenderer shall allow whatever cost he may consider necessary for the carrying out and observance of all clauses and conditions in the Memorandum of Agreement, Conditions of Contract, Special Conditions of Contract and Provisions of this Document.		sum	1	R	-	R	-	R	-	
1,2	<i>Additional Items</i>						R	-	R	-	
1,2,1	Any additional items the Tenderer deems necessary for the successful completion of the installation (specify)						R	-	R	-	
1,2,2							R	-	R	-	
1,2,3								R	-	R	-
1,2,4								R	-	R	-
1,2,5								R	-	R	-
1,2,6								R	-	R	-
1,2,7								R	-	R	-
1,2,8								R	-	R	-
1,2,9								R	-	R	-
1,2,10								R	-	R	-



VROLIJKHEID SOLAR
ELECTRICAL BILL OF QUANTITIES
CT0479-EL-BOQ-0001-R0



No	Description	Specification	Unit	Qty.	Rate		Cost		Total
					Supply	Install	Supply	Install	
2	Low Voltage Distribution Boards						R -	R -	R -
2,1	<i>Modification to Existing Distribution Boards</i>						R -	R -	R -
2,1,1	Modification of Minisub enclosure type MDBs, including additional circuit breakers, cabling and labelling as per SLD: CT0479-EL-SLD-0001	MS1	e.a	1	R -	R -	R -	R -	R -
2,1,2		MS2	e.a	1	R -	R -	R -	R -	R -
2,1,3									
2,1,4									
2,2	<i>Certificates of Compliance</i>						R -	R -	R -
2,2,1	Certificates of Compliance (COC) for each sub distribution board in accordance with SANS 10142 Part 1 (Wiring Code)	MS1	e.a	1	R -	R -	R -	R -	R -
2,2,2		MS2	e.a	1	R -	R -	R -	R -	R -
2,2,3									
2,2,4									
2,3	<i>Additional Items</i>						R -	R -	R -
2,3,1	Any additional items the Tenderer deems necessary for the successful completion of the installation (specify)						R -	R -	R -
2,3,2							R -	R -	R -
2,3,3							R -	R -	R -
2,3,4							R -	R -	R -
2,3,5							R -	R -	R -
2,3,6							R -	R -	R -
2,3,7							R -	R -	R -
2,3,8							R -	R -	R -
2,3,9							R -	R -	R -
2,3,10							R -	R -	R -



VROLIJKHEID SOLAR
ELECTRICAL BILL OF QUANTITIES
CT0479-EL-BOQ-0001-R0



No	Description	Specification	Unit	Qty.	Rate		Cost		Total
					Supply	Install	Supply	Install	
3	Cableways						R -	R -	R -
3,1	Cable Duct (P8000, 76mm x 76mm)						R -	R -	R -
3,1,1	Supply and install P8000 cable duct with splices, PVC lids, jumpers across all joints / splices and complete with all surface fixing material	Straight lengths (linear meters)	m	140	R -	R -	R -	R -	R -
3,1,2		Cover (PVC)	m	140	R -	R -	R -	R -	R -
3,1,3		Steel trunking internal elbow	e.a.	4	R -	R -	R -	R -	R -
3,1,4		Steel trunking external elbow	e.a.	4	R -	R -	R -	R -	R -
3,1,5		Steel trunking end cap	e.a.	4	R -	R -	R -	R -	R -
3,2	Additional Items						R -	R -	R -
3,2,1	Any additional items the Tenderer deems necessary for the successful completion of the installation (specify)						R -	R -	R -
3,2,2							R -	R -	R -
3,2,3								R -	R -
3,2,4								R -	R -
3,2,5								R -	R -
3,2,6								R -	R -
3,2,7								R -	R -
3,2,8								R -	R -
3,2,9								R -	R -
3,2,10								R -	R -



VROLIJKHEID SOLAR
ELECTRICAL BILL OF QUANTITIES
CT0479-EL-BOQ-0001-R0



No	Description	Specification	Unit	Qty.	Rate		Cost		Total
					Supply	Install	Supply	Install	
4	Low Voltage Reticulation						R -	R -	R -
4,1	LV Cables						R -	R -	R -
4,1,1	Supply and install XLPE/PVC/SWA/PVC Copper cables (SANS 1507; 600V/1000V) on a rack or pulled through sleeves or laid directly in the ground of the following sizes: CT0479-EL-SLD-0001 CT0479-EL-LST-0002	50 mm ² 4 core Cu	m	35	R -	R -	R -	R -	R -
4,1,2									
4,1,3									
4,1,4									
4,1,5									
4,1,6									
4,2	LV Cable Terminations						R -	R -	R -
4,2,1	Supply and install cable ends complete with glands, lugs and shrouds of the following sizes:	50 mm ² 4 core Cu c/w IP65 Glands	e.a.	12	R -	R -	R -	R -	R -
4,2,2									
4,2,3									
4,2,4									
4,2,5									
4,2,6									
4,3	Sleeves						R -	R -	R -
4,3,1	Supply and install uPVC medium duty pipes (Class 6) including slow radius bends, cutting, short lengths, straight couplings complete with single length of 2,5mm dia galvanised draw wire installed per pipe: CT0479-EL-LAY-0001 CT0479-EL-LAY-0002	75 mm Diameter	m	320	R -	R -	R -	R -	R -
4,3,2									
4,3,3									
4,3,4									
4,3,5									
4,3,6									
4,4	Excavation						R -	R -	R -
4,4,1	Excavation, bedding, backfilling, compaction and compaction testing of trenches for the installation of cables. Trench dimensions taken as 800mm deep x 400mm wide. Rate to make allowance for trench maintenance (shoring and prevention of water logging) and cordoning off with protective fences to prevent public access. Reinstate any damage to roads or paving.	Excavate Pickable Soil	m ³	132	R -	R -	R -	R -	R -
4,4,2		Supply & Import Sand Bedding (75mm Bed; 75mm Cover)	m ³	29	R -	R -	R -	R -	R -
4,4,3		Backfill and Compaction (Mechanical Tamper)	sum	1	R -	R -	R -	R -	R -
4,4,4		Reinstate / Repair Road or Paving	m	0	R -	R -	R -	R -	R -
4,4,5									
4,4,6									
4,4,7									
4,4,8									



VROLIJKHEID SOLAR
ELECTRICAL BILL OF QUANTITIES
CT0479-EL-BOQ-0001-R0



No	Description	Specification	Unit	Qty.	Rate		Cost		Total
					Supply	Install	Supply	Install	
4,5	<i>Miscellaneous Items</i>						R -	R -	R -
4,5,1	Supply and Install the following complete as specified:	Cable Identification Markers (Engraved Labels)	e.a.	12	R -	R -	R -	R -	R -
4,5,2		PVC Danger Tape to be Installed in Trenches	m	320	R -	R -	R -	R -	R -
4,5,3		3P+N+PE Straight industrial power connector for generator input	e.a.	2	R -	R -	R -	R -	R -
4,6	<i>Additional Items</i>						R -	R -	R -
4,6,1	Any additional items the Tenderer deems necessary for the successful completion of the installation (specify)						R -	R -	R -
4,6,2							R -	R -	R -
4,6,3								R -	R -
4,6,4								R -	R -
4,6,5								R -	R -
4,6,6								R -	R -
4,6,7								R -	R -
4,6,8								R -	R -
4,6,9								R -	R -
4,6,10								R -	R -



VROLIJKHEID SOLAR
ELECTRICAL BILL OF QUANTITIES
CT0479-EL-BOQ-0001-R0



No	Description	Specification	Unit	Qty.	Rate		Cost		Total
					Supply	Install	Supply	Install	
5	Lightning Protection and Earthing						R -	R -	R -
5,1	Conductors						R -	R -	R -
5,1,1	Supply and install earth cable terminated on stainless steel I-Beam clamped to structure.	50 mm² Bare copper earth electrode	e.a	80	R -	R -	R -	R -	R -
5,1,4		16 mm² Flexible Cu bridging cable (500mm lengths) current class N Dehn part no: 377510 or equivalent	e.a	4	R -	R -	R -	R -	R -
5,1,5		500mm Anti-Corrosion tape	m	10	R -	R -	R -	R -	R -
5,2	Terminations to Plant Structure						R -	R -	R -
5,2,1	Supply and install stainless steel I-Beam clamps to structure with lug connections.	Conductor clamping connection Dehn part no: 390059 StSt	e.a	10	R -	R -	R -	R -	R -
5,2,2		I-Beam clamping connection (stainless steel) to earth electrode dehn part no: 372119 StSt	e.a	8	R -	R -	R -	R -	R -
5,3	Terminations to Earth Electrodes						R -	R -	R -
5,3,1	Supply and install terminating lug, cadmium plated bolt, nut and washer for connecting copper conductor.	Self tapping screw 6,3x19mm stainless steel (dehn part no: 528619)	e.a	100	R -	R -	R -	R -	R -
5,3,2		Termination lugs	e.a	100	R -	R -	R -	R -	R -
5,4	Additional Items						R -	R -	R -
5,4,1	Any additional items the Tenderer deems necessary for the successful completion of the installation (specify)						R -	R -	R -
5,4,2							R -	R -	R -
5,4,3								R -	R -
5,4,4								R -	R -
5,4,5								R -	R -
5,4,6								R -	R -
5,4,7								R -	R -
5,4,8								R -	R -
5,4,9								R -	R -
5,4,10								R -	R -



VROLIJKHEID SOLAR
ELECTRICAL BILL OF QUANTITIES
CT0479-EL-BOQ-0001-R0



No	Description	Specification	Unit	Qty.	Rate		Cost		Total
					Supply	Install	Supply	Install	
6	PV Solar						R 400 000	R -	R 400 000
6,1	<i>Inverters and Batteries</i>						R -	R -	R -
6,1,1	Supply SUNSYNK PowerHub 120. Install inverters and batteries as listed in the user manual.	SUNSYNK PowerHub 120 SS-CS-GE-F120 complete all-in-one hybrid ESS comprising integrated 50kW 3-phase hybrid inverter and 120kWh battery storage system.	ea.	2	R -	R -	R -	R -	R -
6,2	<i>PV Solar Modules & Brackets</i>						R -	R -	R -
6,2,1	Supply and install PV Solar Panels as listed on the datasheet. Configure strings as listed on the PV solar module stringing designation. CT0479-EL-LST-0001 CT0479-EL-LAY-0002 CT0479-EL-GAR-0002	620Wp Bifacial PV Solar Panels	e.a	208	R -	R -	R -	R -	R -
6,2,2		Ground-mounting structures for PV array. Priced complete for supply and install to mount all panels at indicated position on site c/w PrEng sign-off.	sum	1	R -	R -	R -	R -	R -
6,2,3		Hardware (brackets, fasteners, etc.) for fixing PV solar panels to ground-mounting structures. Priced per PV solar panel.	e.a	208	R -	R -	R -	R -	R -
6,2,4		DC Junction Boxes	e.a	4	R -	R -	R -	R -	R -
6,3	<i>Cabling, Wiring, and Terminations</i>						R -	R -	R -
6,3,1	Supply and install new DC cabling, wiring and terminations as per the following specifications: CT0479-EL-LST-0002	6mm ² UV-stabilised PV wiring. BLACK Helukabel Solarflex or equivalent approved by Engineer.	m	2400	R -	R -	R -	R -	R -
6,3,2		6mm ² UV-stabilised PV wiring. RED Helukabel Solarflex or equivalent approved by Engineer.	m	2400	R -	R -	R -	R -	R -



VROLIJKHEID SOLAR
ELECTRICAL BILL OF QUANTITIES
CT0479-EL-BOQ-0001-R0



No	Description	Specification	Unit	Qty.	Rate		Cost		Total
					Supply	Install	Supply	Install	
6,4	<i>Miscellaneous Items</i>						R -	R -	R -
6,4,1		2,2m High ClearVu fence around PV Array	m	142	R -	R -	R -	R -	R -
6,4,2		2,2m High ClearVu track-mounted sliding gate	m	6	R -	R -	R -	R -	R -
6,4,3		6-Strand electric fencing installed on ClearVu fence and gate around PV array	m	148	R -	R -	R -	R -	R -
6,5	<i>Additional Items</i>						R 400 000	R -	R 400 000
6,5,1	Any additional items the Tenderer deems necessary for the successful completion of the installation (specify)	Wi-Fi Router with SIM card	e.a.	2	R -	R -	R -	R -	R -
6,5,2		25mm HDPE or UPVC water pipe incl. all fittings. Priced complete for supply and install to connect fire suppression system of each PowerHub 120 to nearest water supply.	m	50	R -	R -	R -	R -	R -
6,5,3		Battery Backup System for Office	PC Sum	1	R 200 000	R -	R 200 000	R -	R 200 000
6,5,4		Battery Backup System for Water Treatment Plant	PC Sum	1	R 200 000	R -	R 200 000	R -	R 200 000
6,5,5							R -	R -	R -
6,5,6							R -	R -	R -
6,5,7							R -	R -	R -
6,5,8							R -	R -	R -
6,5,9							R -	R -	R -
6,5,10							R -	R -	R -



VROLIJKHEID SOLAR
ELECTRICAL BILL OF QUANTITIES
CT0479-EL-BOQ-0001-R0



No	Description	Specification	Unit	Qty.	Rate		Cost		Total
					Supply	Install	Supply	Install	
7	Surveys						R -	R -	R -
7,1	Survey Reports						R -	R -	R -
7,1,1	The contractor to ensure that the following survey reports be compiled for verification of engineer's design.	Electrical usage logging to be performed with a 250A power quality logger at the main incomer of MS1 and MS2 for a 1-week period. A report is to be generated and the recorded data is to be shared with the Engineer. Refer to tender specification for detail description.	e.a.	2	R -	R -	R -	R -	R -
7,1,2		Allowance for a pull test to be performed according to structuree supplier's specification	PC	1	R -	R -	R -	R -	R -
7,2	Additional Items						R -	R -	R -
7,2,1	Any additional items the Tenderer deems necessary for the successful completion of the installation (specify)						R -	R -	R -
7,2,2							R -	R -	R -
7,2,3								R -	R -
7,2,4								R -	R -
7,2,5								R -	R -
7,2,6								R -	R -
7,2,7								R -	R -
7,2,8								R -	R -
7,2,9								R -	R -
7,2,10								R -	R -

C4.3

ANNEXURE B
TENDER SPECIFICATION



Project Title
VROLIJKHEID SOLAR

Project Number
CT0479

Document Title
TENDER SPECIFICATION

Document Number
CT0479-EL-SPE-0001-R0

0	28 May 2026	Issued for Tender	P Fourie	B Human
Rev	Date	Description	Prepared	Approved
Document Control				
Consulting Engineer			Client	
 Unit 25, Muirfield House, Midpark Business Village, 2 Greens Close, Parow, 7500, South Africa t +27 (0) 21 930 4934 m +27 (0) 84 440 9273 info@buhrmannce.co.za www.buhrmannce.co.za			Cape Nature Conservation Board PGWC Shared Services Centre, corner Bosduif and Volstruis streets Bridgetown Gatesville 7766	

TERMS OF REFERENCE

This work has been conducted by Bührmann Consulting Engineers (Pty) Ltd (BCE) for Cape Nature. The scope of work for this report was presented in the letter of appointment, **RFQ-1060-2025-10-167754**, dated **21 January 2026**.

This report, and accompanying drawings, has been prepared by Bührmann Consulting Engineers for the exclusive use of Cape Nature pertaining to the Tender Design Specification for Kogelberg and no other party is an intended beneficiary of this report or any of the information, opinions and conclusions contained herein. The use of this report shall be at the sole risk of the user regardless of any fault or negligence of Cape Nature or Bührmann Consulting Engineers. Bührmann Consulting Engineers accept no responsibility for damages, if any, suffered by any third party as a result of decisions or actions based on this report. Note, that this report is a controlled document, and any reproductions are uncontrolled and may not be the most recent version.

CONTENTS

TERMS OF REFERENCE.....	ii
CONTENTS	iii
NOMENCLATURE	v
1. PROJECT SPECIFICATION	6
1.1 SCOPE DEFINITION.....	6
1.2 REFERENCE DOCUMENTS	7
1.3 ENVIRONMENTAL CONDITIONS.....	9
1.4 ELECTRICAL SUPPLY ON SITE.....	9
1.5 TIME FOR COMPLETION.....	10
1.6 ARRANGEMENTS WITH THE LOCAL SUPPLY AUTHORITY	10
1.7 CERTIFICATE OF COMPLIANCE.....	11
1.8 INSPECTION AND HANDING OVER PROCEDURE.....	11
1.9 ELECTRICAL USAGE LOGGING	12
1.10 STRUCTURAL ENGINEERING REPORT.....	13
1.11 LV SWITCHBOARDS, SUB DISTRIBUTION BOARDS.....	13
1.12 CABLE TRAY.....	16
1.13 WIRING COLOURS.....	17
1.14 CABLES	17
1.15 LABELLING.....	24
1.16 ENCLOSED ROTARY SWITCH DISCONNECTORS	25
1.17 CONDUIT.....	26
1.18 TRUNKING AND WIRE WAYS.....	27
1.19 CONDUIT FOR ELECTRONIC SERVICES	28
1.20 EARTHING AND BONDING	28
1.21 FIRE EXTINGUISHERS.....	32
1.22 PV SOLAR	32
1.23 AS BUILT DOCUMENTATION AND PROJECT CLOSE OUT PROCEDURE	38
2. PREFERRED EQUIPMENT SUPPLIERS.....	39
2.1 PREFERRED ELECTRICAL EQUIPMENT SUPPLIERS.....	39
2.2 TENDER DOCUMENTATION REQUIREMENTS	40
3. DRAWINGS & DOCUMENTS	40

4.	BILLS OF QUANTITIES	41
4.1	GENERAL	41
4.2	DESCRIPTION OF ITEMS IN THE BILLS	41
4.3	QUANTITIES REFLECTED IN THE BILLS.....	42
4.4	PRICING OF THE BILLS OF QUANTITIES.....	42
4.5	BILLS OF QUANTITIES.....	43

NOMENCLATURE

A	Amps
ACB	Air Circuit Breaker
ANSI	American National Standard Institute
GA	General Arrangement
HVAC	Heating Cooling Air Conditioning
IEC	International Electrotechnical Commission
ISO	International Organization for Standardization
kW	kilowatts
LV	Low Voltage
m	meters
MCB	Miniature Circuit Breaker
MCC	Motor Control Centre
MCCB	Moulded Case Circuit Breaker
PLC	Programmable Logic Controller
PVC	Polyvinyl Chloride
RSA	Republic of South Africa
SLD	Single Line Diagram
SWA	Steel Wire Armoured
TTA	Type Tested Assemblies
UL	Underwriters Laboratories
UPS	Uninterruptable Power Supply
V	Volts
W	Watts
XLPE	Cross Linked Polyethylene

1. PROJECT SPECIFICATION

1.1 SCOPE DEFINITION

The scope of the electrical project includes the installation of a PV solar generation and battery backup system at Vrolijkheid Nature Reserve. All works shall be executed and installed in accordance with the supplied layout drawings and single line diagrams.

This specification covers the design, supply and installation of the electrical installation as described below for this project. The commissioning and 12-month free maintenance and guarantee are also included herewith.

The installation shall consist of the following:

- (1) Supply and installation of 2x PowerHub 120 units, mounted on a concrete plinth under a covered structure adjacent to each respective miniature-substation.
- (2) Supply and installation of a ground-mounted PV array, enclosed within a ClearVu type perimeter fence topped with electric fencing, and fitted with a track-mounted sliding access gate.
- (3) Modification of the existing DB within each miniature-substation, as indicated on the single line diagrams.
- (4) Supply and installation of all reticulation cabling/wiring between the DBs, inverters, batteries, and PV array.
- (5) Trenching and reinstatement as required for underground cable routes.
- (6) Supply and installation of a water connection to each PowerHub 120 for the fire suppression water pipe system, with the pipe trenched from the nearest building with an available water supply.

The appointments for the following engineering inspections and reports also form part of the contractor's scope of work:

- (1) Electrical usage logging of MS1 and MS2 for a one-week period. The logging data must include kWh as well as load profile data.
- (2) Structural engineering report, prepared and signed off by a qualified structural engineer (Pr. Eng), confirming the suitability of the proposed ground-mounted PV array support structures and the PowerHub 120 enclosures. Contractor to allow for pull test in accordance with structural engineers' requirements.

1.2 REFERENCE DOCUMENTS

This specification shall comply with the latest edition, including all amendments and requirements, of the specifications, codes and regulations referenced herein but shall not be limited to just those. The Supplier shall clearly define which standards are applicable to the equipment offered.

Modifications for local government regulations, rules and codes shall be made only if they exceed the codes as specified below and must have the approval of the client.

1.2.1 Codes, Standards and Regulations

The work shall be performed in accordance with the most recent versions of relevant codes and standards from the regulatory agencies and institutes.

The Owner's Engineer should be consulted for clarification wherever discrepancies in the technical information exist between the various documents contained in the bid package, reference codes and standards, drawings, specifications, before proceeding with the work.

The design and construction shall conform with Standards prepared by the following authorities:

Standard	Name / Description
SANS 10142 Part-1	The wiring of premises Part 1: Low-voltage installations
SANS 10142 Part-2	The wiring of premises Part 2: Medium-voltage installations above 1 kV a.c. not exceeding 22 kV a.c. and up to and including 3 000 kW installed capacity
SANS 950	Non-metallic conduit fittings for use in electrical installations
SANS 1507	Electric cables with extruded solid dielectric insulation for fixed installations (300/500 V to 1 900/3 300 V)
SANS 1973-1	Low-Voltage Switchgear and Controlgear Assemblies Part 1 Type-tested assemblies with stated deviations and a rated short-circuit withstand strength above 10 kA
SANS 10199	The design and installation of earth electrodes
SANS 60076	Power Transformers
SANS 60529	Degrees of Protection Provided by Enclosure (IP Code)
SANS 60947	Low-Voltage Switchgear and Controlgear Part 1: General rules
SANS 61439	Low-Voltage Switchgear and Controlgear assemblies
SANS 62305	Protection Against Lightning
NRS048	Quality of Supply
SABS 150	Insulated Wire

Standard	Name / Description
NRS 097	Grid Connection of Embedded Generation

1.2.2 *Quality Control and Quality Assurance Standards*

The materials supplied to site shall be of high quality and suitable for the site's climatic conditions. The Employer/Engineer must approve these materials, which must conform to the relevant quality, manufacturing, testing, and performance standards set out in the SANS or the appropriate IEC specifications if no such standards exist. Materials manufactured in South Africa should, as far as possible, be used and bear the SABS mark where applicable. Imported materials must comply with the appropriate IEC specification. All materials must be appropriate for the installation and use conditions. If the materials or components are not suitable for temporary use under the site's conditions, the contractor shall bear the cost of providing suitable protection until the unfavourable site conditions cease to exist.

1.2.3 *Safety Standards*

The design shall conform to standards prepared by the following authorities:

- South African laws and legislation
- Republic of South Africa Occupational Health and Safety Act No. 85 of 1993 (OHSA)

1.2.4 *Precedence, Deviation and Conflicts*

In the event of conflict between parts of the documents referred above, the most stringent standards will take precedence.

Whenever a difference exists between this Specification and the referenced codes and specifications, the order of precedence of documents and specifications is as follows:

- (1) Contractual requirements
- (2) Design drawings
- (3) This document
- (4) Other referenced documents

1.2.5 Other Documents

Important documents that will form part of this project are referenced in Table I.

Table I: Other Reference Documents

Item	Source / Comments
Electrical Bill of Quantities	CT0479-EL-BOQ-0001
All drawings (Refer to Table III for a list of drawings and documents)	-

1.3 ENVIRONMENTAL CONDITIONS

All the equipment supplied shall be suitable for continuous operation under the following conditions:

Item	Value	Comments
Site Location Name	Vrolijkheid Nature Reserve	
Site Location Co-ordinates	33°55'09.12"S 19°52'30.50"ES	
Altitude (ASL)	230m	Inland, Rural
Maximum temperature	+40°C	McGregor
Minimum temperature	-5°C	McGregor
Corrosion	Medium	Inland, Rural
Contamination	Medium	Dusty (Rural/Dirt Roads)
Relative Humidity	60%	McGregor
Seismic Activity (UBC)	N/A	-
Access to Site	Road Access (Dirt Road)	
Security	N/A	-

1.4 ELECTRICAL SUPPLY ON SITE

Note that all electrical equipment specified for this contract shall be able to operate under with the following system voltages:

1.4.1 Supply Voltages

Utilization	Requirement		Comments
Electrical Supply System Earthing	TN-S or TN-C-S or TT		To match existing
Small Power & Lighting (3PH)	230V/400V, 3PH + N + E; 50Hz		-
Total Harmonic Voltage Distortion	5% ($\leq 1\text{kV}$) 5% ($\leq 69\text{kV}$)		-
Voltage Unbalance	2%		-
Frequency	50Hz Tolerance $\pm 2\%$ (49Hz-51Hz)		-
Volt Drop (% of Supply Voltage)	5%	Distribution Feeder Cables	Sum and in Series
	3%	Outlets and Light Circuits from DB	At Full Load
Phase Rotation	A-B-C or L1, L2, L3 or To Be Confirmed on Site		-
Control Auxiliary Power (field control Instruments)	12VDC & 24VDC		-
General Purpose Socket Outlets	230 VAC, 16A, 1 Phase+ Neutral+ Ground. All outlets ground leakage protected. SA 3-Pin and Euro Combination (SANS 164-1 & 2) or British Standard BS1363		-
LV Circuit Breakers	For 3 Phase + Neutral Circuits – 4 pole – For safe isolation For 1 Phase Circuits – 1 pole		-
230V, 50Hz	Outdoor Lighting		-
230V, 1PH, 50Hz (Solidly Grounded)	Indoor Lighting, receptacles, motors up to and including 0.37kW and heater supply for motors / equipment (derived from Vendor-provided auxiliary transformer and distribution panel)		-

1.5 TIME FOR COMPLETION

The time for completion shall be as indicated in the Schedules of the Agreement.

1.6 ARRANGEMENTS WITH THE LOCAL SUPPLY AUTHORITY

The supply to the site exists and does not need to be upgraded.

The Local Supply Authority is the **Langeberg Municipality**.

The **Contractor** shall notify the Local Supply Authority of commencement of construction work.

The **Contractor** shall ensure that the installation complies with the local authority's special requirements.

1.7 CERTIFICATE OF COMPLIANCE

All work covered under this contract that has to be carried out on site, must be executed by a qualified and fully representative person. Only persons registered as an "installation electrician" will be accepted to carry out the installation work. After completion of the contract the Contractor shall submit a Certificate of Compliance in terms of the OHS-Act to the Engineer prior to final payment being processed.

Where alterations are made to distribution boards, the certificate only need to cover the alterations made to the distribution board.

A certificate shall be issued for every distribution board in which work is carried out.

1.8 INSPECTION AND HANDING OVER PROCEDURE

1.8.1 *Inspection by contractor*

When the installation is completed, the Contractor shall conduct an inspection to satisfy himself that all connections have been properly fastened, that all labels are engraved and properly fixed, that no bolts and screws are missing, and in general that the installation has been completed to the requirements of the specification and that the workmanship complies with the applicable standards and to the satisfaction of the Engineer.

1.8.2 *Testing by contractor*

Upon completion of the work, the Contractor shall perform all tests as specified or as required by the Engineer to ensure that all equipment and cabling have been connected correctly, and that the installation is ready for handing over and commissioning.

The Contractor shall provide his own test equipment, which shall be of acceptable standards.

1.8.3 *Inspection and testing by engineer*

After the Contractor has conducted the abovementioned inspection, he shall apply in writing to the Engineer for a handing over inspection. At least **2 days'** notice shall be given.

The following forms shall be thoroughly completed by the Contractor. These forms are not included in the contract, but the forms basically consist of the following:

In commissioning and handing over certificate:

- (1) Application form.
- (2) Visual inspection list.
- (3) Earth leakage tests.
- (4) Conductor resistance tests.
- (5) Insulation resistance.
- (6) Functional tests.

Other standard forms:

- (7) Notice of Commencement of Installation Work
- (8) Application for Inspection
- (9) Certificate of Acceptance
- (10) Certificate of Compliance by an Accredited Person
- (11) As-built quantities and materials used

Should the completed section not pass the inspection, the Contractor shall rectify the fault(s) and apply for re-inspection.

One (1) re-inspection of the work as a whole, shall be conducted free of charge. The Contractor shall incur a penalty of **R2000-00 (Two Thousand Rand)** for all subsequent re-inspections required on the contract and this amount will be deducted from the next payment due to the Contractor.

1.9 ELECTRICAL USAGE LOGGING

The contractor shall ensure that a power quality logger is connected to MS1 and MS2 main incomers so that the electrical usage can be logged for a one-week period. A one-minute sampling resolution must be used.

The logging company and the details of the logger to be used must be approved by the Engineer.

A basic report must be provided. At minimum, the report must show per-day graphs depicting the:

- 1.) Per-phase and summed Apparent, Real and Reactive Power usages
- 2.) Per phase and summed energy consumption
- 3.) Per-phase line to line and line to neutral Voltages
- 4.) Per-phase line to line and line to neutral Current

5.) Per-phase and overall Power Factor

The complete logged data must be shared with BCE for in-office inspection. If the data cannot be shared in a format that is conveniently viewable, BCE may request that the report be expanded to show additional data.

1.10 STRUCTURAL ENGINEERING REPORT

The Contractor shall procure a structural engineering report, prepared and signed off by a qualified structural engineer (Pr. Eng), to confirm the suitability of the proposed ground-mounted PV array support structures and the PowerHub 120 enclosures. Contractor to allow for pull test in accordance with structural engineers' requirements.

1.11 LV SWITCHBOARDS, SUB DISTRIBUTION BOARDS

1.11.1 General

The following LV Switchboards, Sub Distribution Boards shall form part of this tender:

- (1) MS1 Low Voltage DB
- (2) MS2 Low Voltage DB

The LV Switchboards & Sub Distribution Boards shall be manufactured/modified according to the schematic distribution board drawings.

The LV Switchboards & Sub Distribution Boards construction/modification, physical and electrical requirements are indicated on the above drawings.

The LV Switchboards & Sub Distribution Boards supplier shall be responsible for the physical design of the LV Switchboards & Sub Distribution Boards in accordance with the requirements of the specification and the schematic layout diagrams forming part of the documentation.

On completion a Certificate of Compliance shall be issued for the LV Switchboards & Sub Distribution Boards installation.

1.11.2 Grouping of equipment

All equipment on distribution boards shall be mounted behind hinged panels. Hinged lockable doors shall enclose the panels.

The grouping of equipment shall be arranged in order that future extensions and additions may be done in a logical fashion.

1.11.3 Outgoing circuits

All outgoing circuits of the local section of distribution boards with a rating equal or less than 40A shall be wired to terminals. Terminals shall be provided for the live as well as the neutral conductors of the circuits. The circuits shall be grouped with the live and neutral terminals of a circuit adjacent on the terminal strip.

Terminals shall be DIN-rail mounted and shall be of the Sprecher & Shuh or approved equivalent manufacture.

1.11.4 Hardware

Where required door hinges shall be of the Procast, Perano or Barker Nelson manufacture.

If lockable doors are indicated on the schematic drawings, the front panels shall be lockable with catches using the Client's standard key. Alternatives will not be accepted unless authorised by the Engineer in writing.

1.11.5 Equipment ratings

All equipment utilised in distribution boards shall be rated at 400/231-Volt AC. Circuit breakers shall have a minimum rupturing capacity of 5kA unless otherwise indicated on the drawings.

1.11.6 Approval procedures

The Electrical Contractor is advised to order the distribution boards from a reputable manufacturer, as inferior boards will not be accepted. The Electrical Contractor shall submit the details of the board builder that he intends to use, for approval by the Engineer, with his tender.

The Engineer will not approve the workshop drawings of the boards unless all information as requested is submitted as a complete package. General arrangement drawings or incomplete drawings will not be considered to be a complete package and shall be returned to the contractor forthwith.

It shall further be noted that late approval of workshop drawings or distribution boards, due to non-compliance with the specifications, schematic layouts and diagrams, or approval procedures as specified in this document, will not relieve the Electrical Contractor from any of his obligations to complete the contract according to programme. No claims for delays, for extension of time or extra costs in this regard, will be entertained.

The following procedure for the approval of distribution boards and workshop drawings is to be strictly followed:

- (1) Electrical Contractor appoints board manufacturer.

- (2) Board manufacturer submits workshop drawings for approval, to the Electrical Contractor.
- (3) Electrical contractor checks workshop drawings for compliance with all requirements of the specifications, schematic layouts and diagrams, and submits 3 copies, signed off as checked, to the engineer for approval.
- (4) The Engineer returns 2 copies as approved or for re-submission, to the Electrical Contractor.
- (5) Manufacture of equipment commences after approval of the drawings by the Engineer. Workshop drawings shall include the scaled and dimensioned general arrangement, sections, busbar dimensions, equipment clearances, cubicle layouts, busbar stubs, instrumentation of details, equipment, comprehensive wiring diagrams, terminal and cable numbers, etc. The wiring diagrams shall be complete with wire and terminal numbers as well as the status of each contact, normally open or normally closed. The wiring diagrams shall include the description of all symbols used in the diagrams.
- (6) Electrical Contractor checks and inspects boards at the manufacturer during all stages.
- (7) Electrical Contractor presents the Engineer with written confirmation that the boards are in full compliance with the specifications, schematic layouts and diagrams, that they have been checked, inspected, and fully tested. This confirmation, signed and dated by both the Electrical Contractor and board manufacturer is to accompany a written request, by the Electrical Contractor, for the Engineer to witness the re-inspection and re-testing of the distribution boards. The Electrical contractor shall also confirm that each of the distribution boards will fit into the space or area allocated.
- (8) During the inspections, a fault list, if necessary, will be drawn up and handed to the Electrical Contractor.
- (9) After satisfactory rectification of the fault list, and subsequent re-inspection, the Electrical Contractor may instruct the board manufacturer to dispatch the boards to site. No repairs or rectification of fault list items will be permitted to be carried out on site.
- (10) Under no circumstances will the Engineer enter into any discussions regarding conformance to specifications with the board manufacturer. All communication will only be directed to the Electrical Contractor from either the Engineer or the board manufacturer.
- (11) The Electrical Contractor shall ensure that a full copy of the specifications as well as a copy of the drawings, which were approved and signed by the Engineer, is at hand, during all inspections.
- (12) All tests, i.e. pressure tests, trip tests, injection tests, and functional tests shall be carried out as specified in the technical specification, at the premises of the board manufacturer. All tests as specified shall be performed by the board manufacturer for the Electrical Contractor, and shall be repeated for witnessing by the Engineer. The Electrical Contractor shall ensure that all tests as specified are carried out, and shall satisfy him that all equipment irrespective of the source, or origin, or supplier, will perform satisfactorily in site tests and future continuous use.

1.12 CABLE TRAY

All cables shall be installed on:

- Galvanized steel cable ladders or equivalent
- Cables shall be installed on ladders and trays in a single layer and held in position with stainless steel straps.
- Power and control/instrumentation cables shall be segregated by installation in separate conduits or, where run on a common cable ladder or tray, a metal segregation barrier shall be provided between power and control/instrumentation cables.

Cable tray shall be:

- Standard ladder type tray (cable ladders) used in plants should be medium-duty type.
- All trays to be hot-dipped galvanized steel.
- Standard sizes for cable ladder used are 100mm, 150mm, 200mm, 300mm, 400mm, 600mm, 800mm and 1000 mm wide.
- Ladder type tray shall have 300 mm rung spacing, and shall have rail heights at 100mm.
- Cable tray shall be perforated type, with side rail height 50 mm.
- All installations in the cable tray shall have maximum three meters (3 m) between support points.

In general, the cable tray support system must comply with the following requirements:

- All cable trays must be laid **horizontal**. Vertical tray mounted on its side shall only be installed in areas where spacing for horizontal trays is not adequate.
- Cable tray shall be supported rigidly, so as to prevent excessive vibration or deflection.
- Cable tray support spacing shall not exceed 3 m.
- Wall, floor and ceiling openings and penetrations shall be sealed with approved waterproof fire barriers.
- All vertical runs shall be properly clamped – maximum spacing 1.5 m.

Heavy-duty galvanized steel cable tray systems must be continuously bonded by grounding cables routed in the tray and bonded to the tray every 6 m. The grounding cables shall be grounded to structural steel support at max. 20m intervals.

Where a number of cable trays are installed in tiers, each cable tray shall be connected by a bonding conductor to the next one, every 15 m. The lowest cable tray shall be grounded to structural steel support at maximum 15 m intervals.

Cable tray system shall consist of straight runs required fittings (tees, elbows, reducers, etc.). Construction, fabrication, and Installation of all cable trays shall be per IEC/SANS standard.

1.13 WIRING COLOURS

1.13.1 Electrical Power Supply – Panel Wiring

Colour - Phase L1	Red
Colour - Phase L2	White / Yellow
Colour - Phase L3	Blue
Colour - Neutral	Black
Earth	Green; Green/Yellow; Bare Copper

1.13.2 Small Power Supply - Panel Wiring

12 & 24Vdc	Positive (L+)	Red
	Common (M)	Black
110Vac	Live (L1)	Brown
	Neutral (N)	Blue
230Vac	Live (L1)	Brown
	Neutral (N)	Blue
Earth		Green; Green/Yellow
Note		Never use 110Vac and 230Vac in the same panel.

1.14 CABLES

1.14.1 General

The tender price shall include for the supply, delivery, installation, testing and commissioning of all cables referred to in the cable schedule, drawings and specifications including all terminations, ends and connections.

All cables shall:

- Have copper multi-strand conductors unless otherwise specified.
- Be circular multicore type with integral ground conductor.
- Be protected against overload and short circuit.
- Be adequately protected against mechanical damage over the entire route length.
- Be of minimum size:

- Power: 2.5mm²
- Control: 1mm²
- Instrument pair/triple: 1mm²
- All cables shall be terminated by means of suitably sized metal weatherproof-type cable glands, shrouds and lugs to suit the hazardous area classification. Shrouds shall cover the gland completely.
- Single core cables shall be terminated via a non-ferrous gland plate (minimum thickness of 3mm) and non-ferrous glands. Aluminium is preferred.
- Have cable numbers in accordance with the cable numbering system at each end of each cable.
- Colours shall not be changed between source and device.
- All conductors (including spare conductors) must be terminated on terminal blocks at all points and properly identified.
- Allow 25% spare cores in multi-conductor control cables. For equipment fixed in design and of standard connection, spare cores are not required.
- Multi-conductor cable cores are to have each individual core tagged at both ends with a unique alphanumeric code (prefer numbered cores to colour coded).
- Low voltage control systems should use minimum 1mm² stranded wire in cables (as per system requirements).
- All wires shall have stranded copper conductor per applicable SANS standards with XLPE insulation. Solid conductor cables are not acceptable. Flexible cords are not acceptable.
- Calculated wire sizes for loads shall allow for:
 - Voltage drop at full load to any receptacle not to exceed: 3%
 - Voltage drop at full load to any lighting fixture not to exceed: 3%
 - Voltage drop to control or signal circuit elements not to exceed: 2%

1.14.2 Low Voltage Cables

All low voltage cables shall have stranded copper or aluminium conductors, shall be new and shall be of the XLPE/PVC/SWA/PVC type, 600/1000 V grade and shall comply with SANS 1507. Single core cables shall have stranded copper or aluminium conductors with PVC insulation and PVC sheath, and shall comply with SANS 1507.

Copper earth conductors shall be installed with each cable and shall be strapped to the cable at 2000-mm intervals. The bunching of earth conductors is not acceptable.

The following test shall be performed after cables are installed:

- (1) Insulation Testing (1000V megger SANS 1507)
- (2) Correct phase rotation

XLPE Cables shall be subjected to a very low frequency test and not a DC Pressure Test.

All test results shall be submitted to the Engineer in writing before the final commissioning of the equipment and cables take place.

It shall be the **responsibility of the CONTRACTOR to verify the correct lengths of each cable on site before placing an order**. The CONTRACTOR will be paid for installed cables only. No reimbursements will be made for the remaining cables on drums under any circumstances.

Cables shall generally be installed in cable trenches or on cable ladders and trays. Where cables are run on surface, against walls, on floors or against machines or structures, these cables shall be installed in galvanised conduit sections to afford mechanical protection. Fixing of cables directly to floors, walls or equipment by means of saddles will not be permitted. Only raised type, alloy saddle bases with plated or galvanised saddles will be permitted for the installation of conduit sections.

1.14.3 Instrumentation Cables

General instrumentation cables shall, in addition to general requirements:

- Have flame-retardant PVC insulation, 300 V insulated, UV resistant grey PVC sheathing.
- Have plain annealed multi-strand copper conductors.
- Have individual pairs, twisted.
- Have core identification as follows:
 - Have pair colors black and white
 - Have 3-core colors: red, white, and black
 - Have pair/triple number digit on each core
- Have screens of aluminum polyester with drain wire.
- Have an aluminum copolymer water barrier bonded to the outer sheath where direct buried.
- Intrinsically safe installations shall comply with the following requirements:
 - In addition to the requirements of general instrumentation cables, intrinsically safe cables shall have individual and overall screens and a light blue sheath
 - Withstand a test voltage of 500 V rms between any cores and between any core and any screen
 - Have an insulation resistance between screens of not less than 1 m ohms/km at 500 Vdc and after the test voltage has been applied for 1 minute

- Shields shall be continuous through all terminals and panels and only be terminated at the control system end to avoid ground loops.
- Panel control wire conductor insulation shall be type THHN (thermoplastic high heat – resistant nylon coated).
- All control cables shall be installed with 25% spare conductors.
- Control cables containing more than two conductors will be purchased with all conductors having the same color (black) with identification from 1 to the last conductor number in the cable.

1.14.4 Cable routes and installation

All joints and taps shall be made with solderless crimp-type compression connection, securely fastened so as to remain tight under vibration or normal strain and insulated properly.

All wires installed shall be without splicing. Interconnections shall be made at terminal blocks in junction boxes where indicated.

Cables shall generally be installed on cable ladders or welded mesh cable trays and shall follow the cable routes as indicated. If a route for a particular cable is not indicated, the Contractor shall choose a route as close as possible to the indicated route, and shall obtain approval from the Engineer for this route beforehand. The Contractor shall take cognisance of the heights of the structures and changes in levels and planes in the cable routes and shall allow for all riser cable ladders.

Cable runs shall be planned to avoid the crossing of cables, which will only be acceptable, if it is impossible not to cross over.

Cables installed in cable trenches shall be neatly laid preferably without crossovers. Earth conductors shall be strapped to the associated cables with suitably sized cable ties at 2m intervals.

Specific care shall be taken in the installation of single core cables (particularly the neutral conductor) to not have the cables separated by ferrous elements. Cables shall be laid in trefoil formation with the neutral conductor in close proximity to the trefoil. Suitable trefoil clamps shall be used to prevent damage due to electromagnetic forces on conductors due to short circuits and fault conditions.

1.14.5 Cable Bending Radii

Cable bending radii shall not be less than the following:

PVC Insulated Cables ($\leq 1000V$)

- Multi & Single Core ($16\text{mm}^2 - 50\text{mm}^2$): 8 x d
- Multi & Single Core ($\geq 70\text{mm}^2$): 10 x d

XLPE Insulated Cables

- Single Core ($\leq 11\text{kV}$): 17 x d
- Multicore ($\leq 11\text{kV}$): 15 x d

1.14.6 Cable Segregation

Cables for different electrical services shall be grouped as follows:

- Low Voltage Cabling
- Instrumentation and Communication

Generally each group shall be allocated to a separate cable ladder.

The minimum distance between High Voltage cabling and Telecommunications cable in parallel runs shall be 300mm.

The minimum distance between Low Voltage cabling and Instrumentation cable in parallel runs shall be 300mm.

1.14.7 Cable Spacing

The spacing between individual cables shall be as follows except if indicated otherwise on drawings:

Cables on Cable Ladder

- LV Cables $\leq 4\text{mm}^2$: Maximum of two layers and touching
- LV Cables $\geq 6\text{mm}^2$: Maximum of single layer and touching
- LV Cables Trefoil: Single layer, trefoil groups one cable diameter apart
- Instrumentation, control, small power and lighting: Multi-layered up to 75% of the depth of the cable ladder.

Cables Underground

- LV Cables: Trefoil arrangement spaced 150mm apart
- LV Cables: Multicore cables spaced 150mm apart

1.14.8 Cable Securing (Cable Ties)

Cables shall be tied to ladder using UV stabilized nylon cable ties (Black) and Stainless-Steel Bandit Straps unless otherwise specified.

Cables on cable ladder shall be neatly laid in parallel runs with no crossing over of cables except at take-off points.

Cables shall be tied to the cable ladder on the following intervals:

- Vertical Runs: All cables to be tied every second rung of cable ladder (600mm intervals)
- Horizontal Runs: All cables to be tied every third rung of cable ladder (900mm intervals)

The maximum number of cables tied together shall be four.

Cable ties shall be correctly sized as follows:

- PVC or XLPE Armoured Multicore $\leq 25\text{mm}^2$ a minimum of 8mm wide Nylon ties
- PVC or XLPE Armoured Multicore 35mm^2 to 70mm^2 a minimum of 12mm wide Nylon ties
- PVC or XLPE Armoured Multicore $\geq 70\text{mm}^2$ a minimum of 10mm wide Stainless-steel straps

1.14.9 Cables Installed in Sleeves

All sleeves for MV and LV cable shall be rated for heavy duty application and be manufactured from uPVC. Sleeves shall conform to SANS 791 (Class 6).

Sleeves shall be sized as follows unless specified otherwise on drawings:

- LV Cables: 110mm diameter (uPVC, Class 6)
- Data Services: 110mm diameter (uPVC, Class 6)

Sleeves shall be installed at the following depths:

- Sleeves for LV Cables: 800mm to top of sleeves
- Sleeves for Data Services: 800mm to top of sleeves

The allocation of cables per sleeve shall not exceed:

- LV Cables: One cable per sleeve
- Equipment & Site Lighting: Four cables per sleeve

1.14.10 Cables Installed Underground

Underground cables shall be laid directly in the ground and be bedded in sand.

The Contractor shall be responsible to ascertain the final ground levels prior to excavating.

The Contractor shall be responsible to obtain the necessary permits and wayleaves prior to excavating.

Furthermore, the Contractor shall be responsible to establish the location of other services (i.e. Telecommunication cables, pipes and ducts) which may cross the proposed trench. The Contractor shall be responsible to repair any damages to the aforementioned services at his own expense.

Trenches shall have parallel sides and shall be free of any protruding objects.

Trenches shall be cordoned off with protective fences and the trench shall be maintained to prevent wall collapse and entry of water.

The minimum radius for change in direction shall not be less than 1m or the minimum bending radius of any cable laid along the trench, whichever one is greater.

Cables shall be laid in clean sand with a minimum bed of 75mm and a minimum cover of 75mm. Prior to placing the sand the Contractor shall ensure that the trench is clear of any sharp objects.

Cables shall be laid in straight runs along the trench and spaced 150mm apart.

Immediately after the laying of cables the cable route shall be marked up on an **as-built** drawing. Dimensions to landmarks shall be indicated to ensure ease of cable finding for maintenance purposes.

Trenches shall be backfilled in 150mm layers. Each layer shall be compacted by means of a mechanical tamper.

The contractor shall be responsible for the procurement and transport of suitable sand bedding. Furthermore, the Contractor shall be responsible for the transport of backfill material to the trench and the disposal of surplus backfill material.

Warning tape shall be installed 150 mm above the cables. The warning tape shall be a continuous strip of 150mm wide orange PVC marker tape with the words: '**Attention Cable Danger**'.

Cable Depth

Cables shall be installed at the following depths below finished ground level:

- LV Cables: 800mm to top of cable

1.14.11 Earth cables and wiring

All earth wires shall be of the stranded copper type, (insulated except where otherwise indicated) and shall follow the same route as the cables. The cross sectional area of all earth wires shall be as indicated on the drawings.

Earth wires shall be installed with all cables, and shall be strapped to each cable at 2-m intervals. Each continuity conductor shall be strapped to its corresponding cable. Collective bunching and strapping of earth continuity conductors is not acceptable.

Earth continuity conductors to outlets shall be of the green / yellow PVC insulated type with stranded copper conductors.

1.15 LABELLING

All electrical components (relays, switches, fuses, breakers, etc.) and door-mounted devices shall be tag identified at the component location with a suitable designation and likewise identified on any/all drawings supplied by the supplier. All meters, relays, etc., shall be provided with panel-mounted engraved Traffolyte nameplates (black with white background).

The labels shall be Traffolyte labels engraved with black letters and numbers on white background. Warning and danger labels shall have white lettering on red background.

The labels shall have bevelled edges.

Labels and tags shall be fitted to equipment prior to transporting to site to enable ease of identification during construction.

Local control station labels shall have identical wording to the labels installed on the associated motor starters. Each light switch and power outlet shall be labelled to identify the origin of the final sub-circuit supplying it. The label shall correspond with the identification of the respective final sub-circuit fuse or circuit breaker.

Nameplates should not be fixed on removable covers. Labels shall be fixed to the panel sheet metalwork. They shall not be fixed to equipment items or duct covers and shall not be obscured by wiring. Labels within panels shall have 5 mm minimum lettering.

The following electrical equipment shall be labelled with lettering heights:

- Main Equipment (e.g., Switchboard, Control Panel): 20 mm
- Danger Labels: 20 mm
- Secondary Equipment (Field Push Button Station, Field Instrument Identification, Junction Box Identification): 10mm
- Marshalling / RIO Panels: 10 mm
- Pushbutton, indicating lamps, selector switch: 6 mm
- Pushbutton, indicating lamps, selector switch: 6 mm
- Equipment mounted inside panels (e.g., relays, fuses): 3 mm
- Field Instruments: 3 mm

Equipment numbers and labels located in the field shall be engraved stainless steel, secured to the equipment with stainless steel screws, nuts and washers or stainless-steel wire ties for instruments.

Nameplates for outdoor equipment shall be stainless steel, 316L type. Nameplates for indoor equipment and the interior of outdoor equipment shall be lamacoid type.

Nameplates shall be attached with stainless steel screws. Attaching nameplates with a chemical compound is not acceptable.

Equipment identification labels or nameplates shall be minimum 200 mm x 50 mm with bevelled edges. Letters shall be block type measuring 6 mm x 6 mm with 10 mm line spacing.

Main equipment tag number nameplates shall be minimum 1.6 mm thick with 20 mm high characters

Motor tags shall be mounted on the local control station. All other equipment shall have the tags mounted on their front covers, where they are easily read.

Terminal blocks shall be identified with block-mounted labels.

Each phase of alternating current switchgear and connections shall be coloured in an approved manner to distinguish phase or polarity. Colours shall be permanent and free from fading.

1.15.1 Wire and Cable Tagging

Wire and cable tagging will be as follows:

- Cables shall be tagged with the cable number shown on the cable schedule, at both ends.
- Cable tags shall be imprintable, stainless steel (304 or 316) type
- Resistant plastic of type resistant to salt water, acid and caustic, of field-printable type or pre- printed carrier type, with the following preferred dimensions: 20 mm x 100 mm x 1.2 mm (WxLxD)
- The tag should be able to accommodate 2 lines of 20-character text with 5 mm letter sizing and be compatible with cable ties. Some examples of suitable cable tags include ABB (Thomas and Betts) SSID series, Siegrist-Orel itag CLXi series, and Critchley K-type series.
- Wires shall be identified with the wire tag shown on the drawings at both ends, with machine- printed labels on heat shrink-type sleeve-type wire markers

1.16 ENCLOSED ROTARY SWITCH DISCONNECTORS

As per IEC 60947-3 the following enclosed switch disconnectors will be supplied and installed:

Enclosed Rotary Switch Disconnectors for connection to equipment shall have the following characteristics:

- Surface mounted
- Environmental protection to be **IP65**
- Red rotary switch with yellow lockout ring

- **Lockout** facility for a padlock
- Plastic enclosure
- Available in four or two pole
- Rated at 16, 32, 40, 63, 80, 100, 125 or 160A as determined by the upstream circuit breaker
- **1NO + 1NC Auxiliary Contacts** for feedback to a PLC (SCADA system)
- Rotary switch disconnectors (400VAC) shall be equal or approved to the type **Gewiss 70 RT**
- Rotary switch disconnectors (1000VDC, PV Solar) shall be equal or approved to the type **Santon D14-G-W Range**

1.17 CONDUIT

The use of PVC conduit, fittings and accessories is only permissible where cast in or chased into brick walls. Even though some of the distribution boards may be shown as surface mounted, all conduits shall be built in or cast in. Surface mounted conduits shall not be permitted except where specifically called for.

Where PVC conduit is installed, all joints shall be lightly sanded and glued using appropriate PVC based glue. Conduit cast into concrete shall be securely tied to the reinforcing on both sides of a joint.

The Contractor shall carefully plan the surface mounted conduit runs with all the services for which they will be required prior to the installation thereof. Crossovers shall be kept to a minimum and where they occur, all the conduits running in one direction shall be kept on a base level with all the conduits crossing over in the other direction being offset over the base layer of conduit. The practice of crossing over at an ad hoc basis with a resultant weaving of conduit appearance shall not be tolerated.

All surface conduits shall be of the galvanised steel BOSAL type and bear the SABS mark of approval.

Galvanised screwed steel conduits, minimum diameter 20 mm. Open conduit system shall be allowed only for armored cables. For non-armored cables, it will require elbows (closed conduit system).

Where flexible elbows are required for galvanised conduit steel Sprague tubing covered with PVC shall be used, similar to type Kopex.

All surface conduits (where specifically called for) against painted surfaces shall be painted to match the surfaces on which it is installed. The galvanising shall be lightly sanded to remove all surface oxidation, oil or dirt. The conduits shall be primed by means of an etching calcium plumbate primer. Zinc chromate primers shall not be used, as they are not suited to galvanised finishes. The conduits

shall then be finished in 2 coats of gloss enamel in a matching colour. The gloss enamel coat shall be applied BEFORE the conduits are cut or installed. Inferior paintwork shall be rejected.

All surface mounted conduits where called for shall be installed using raised type alloy bases with galvanised or plated saddles. The alloy bases shall be fixed to the mounting surface by means of M5 brass machine screws. The saddles shall be fixed to the alloy bases by means of M5 pan head plated machine screws. **Self-tappers will not be permitted.**

Conduit saddles shall be fixed to roof timber or structures by means of screws. Nails will not be permitted.

Chasing by means of hammer and chisel will not be accepted. All chasing work shall be carried out by means of power driven machinery using abrasive cutting discs.

All steel conduits shall be securely bonded to earth at the distribution board tray.

Bushes shall be fitted to the cut ends of all steel conduits.

All chasing in walls will be plumb and straight and done in a neat manner. No slow bends will be accepted.

Surface conduits, where called for, shall be installed parallel and plumb with the gridlines of the building or structures to which it is fixed.

1.18 TRUNKING AND WIRE WAYS

The wiring channels shall be suspended in the positions as indicated on the drawings. Care shall be exercised to ensure that the fixing of wire ways shall no lead to sharp protrusions in the wire ways leading to possible damage to wiring. Wire ways for power or lighting shall be terminated directly onto the respective distribution boards.

Punching for power and light unswitched socket outlets shall be provided at 500-mm intervals. Safety barriers shall be provided for all socket outlets. The standard size of the ducting shall be 123 x 75 mm unless otherwise specified on the drawings.

The covers for the ducting shall be manufactured from steel and shall either be a snap-in type lid or shall be provided with a non-removable catch type system. Drop-on covers shall not be permitted.

Wiring channels shall generally face upwards for ease of wiring.

The channels down the columns or walls shall be fixed thereto with purpose made galvanised brackets. Shot fired fixing of the brackets to concrete columns or walls may be employed.

This contract includes the drilling of all holes and making good of resultant damage, for the fixing of cable trays, wire ways and supports.

Where applicable, cables to luminaires or to sockets shall pass through conduits of suitable size. The conduit shall be fitted with brass bushes at both ends. The conduits shall be fixed with raised hospital type saddles. The cable need not pass through conduit around cable bends.

The openings in walls and slabs through which cable trays and wire ways pass shall be sealed after commissioning of the installation with an approved non-hardening compound. The above compound shall prevent a fire from propagating through the openings.

In the case where conduit is required to run to equipment and where a wall or structure is not available, the conduit shall be supported by means of a 75 x 75-mm hot dipped galvanised square section tube. The square section shall be bolted to the cable tray and to the relevant equipment or steelwork. Both ends of the tube shall be sealed by means of welded end plates.

All wire ways shall have purpose made end caps and metal covers.

All wire ways and cable trays shall be colour coded to identify its intended use with permanent painted bands as specified elsewhere.

1.19 CONDUIT FOR ELECTRONIC SERVICES

Refer to the requirements for conduit as specified elsewhere.

All electronic services will be supplied and installed under separate contracts. The supply and installation of conduit, wire ways, draw boxes and Telephone Distribution boards, however, form part of the Electrical Installation work.

All conduits shall be fitted with galvanised steel draw wires.

1.20 EARTHING AND BONDING

1.20.1 General

All earthing and bonding shall be done in accordance with SANS 10292, SANS 10142-1 and the Occupational Health and Safety Act as amended.

The Supply Authority Earth Conductor shall be connected the Main DB earth bar as well as the additional earth spike as indicated on the drawings. All outgoing circuits shall be earthed to the electrical earthing system and replicate the electrical distribution network with a dedicated earth conductor for every cable feed to sub distribution boards or equipment.

Metallic parts shall be bonded to the electrical earthing installation as per the requirements of SANS 10142-1.

The earthing installation shall comply with the requirements of:

- Occupational Health and Safety act, Act 85 of 1993 as amended (including regulations),
- Mine Health & Safety Act , Act 29 of 1996 as amended (including regulations),
- Explosives Act, Act 15 of 2003 as amended (including regulations),
- SANS 10142-1 as amended: The wiring of premises. Part 1: Low-voltage installations,
- SANS 10292: Earthing of low-voltage (LV) distribution systems,
- SANS 10313: Protection against lightning – Physical damage to structures and life hazard,
- SANS / IEC 62305-1: Protection against lightning. Part 1: General principles,
- SANS / IEC 62305-2: Protection against lightning. Part 2: Risk management,
- SANS / IEC 62305-3: Protection against lightning. Part 3: Physical damage to structures and life hazard.

1.20.2 Earth Electrodes

Earth electrodes shall be a minimum of 16mm diameter copper sheathed steel rods ranging in length from 1,8m; 3,6m; 6m & 12m

Generally, earth electrodes shall be spaced a minimum length of an earth electrode apart.

If the ground is too hard to drive the earth electrode into the ground 40-80mm diameter holes will be drilled (ranging from 6m – 15m depths). The holes will be filled with conductive concrete made up from mixing Bentonite with the backfill material as per the recommendation of the Bentonite supplier. The Contractor shall ensure that the connection between the earth electrode and the earth cable is exposed as to allow for future maintenance.

If the ground has a very high earth resistivity the same methodology of employing conductive concrete made up from mixing Bentonite with the backfill material as per the recommendation of the Bentonite supplier shall be employed.

1.20.3 Earth Conductors

Buried earth conductors shall be BCEW (Bare Copper Earth Wires) and be installed at a minimum depth of 800mm below the natural ground level.

Earth conductors to movable equipment or hinged equipment shall be braided flexible copper.

In general, all other earth conductors installed above ground shall be green PVC covered stranded copper conductor unless otherwise specified.

1.20.4 Earth Connections

All buried and exposed taps, splices and connections in bar and cables shall be made by brazing or exothermic welding unless otherwise specified. The pre-welding treatment of the conductors shall be in accordance with the manufacturer's instructions. All buried connections will be inspected by the Engineer prior to burial.

Exposed bolted connections in earthing conductors shall be protected from corrosion by covering with approved sleeving or tape (Denso Tape).

Conductor clamps shall be made of a strong cast bronze body to provide a high pressure contact between the earth conductor and earth electrode. The clamp shall be provided with a non-ferrous set screw.

All lugs crimped to earth conductors of 16mm² or larger shall be crimped by means of hexagonal type crimpers. Dimple crimping of these shall not be accepted.

1.20.5 Earthing of Equipment

All equipment shall be earthed by means of earth continuity conductors run either singly or together with power supply cables.

The following conductors and cables parts shall be connected to the earth bar at the point of supply and the earth stud of all equipment to which the respective conductors and cables are connected to:

- Earth Conductors
- Metallic Armouring of High & Low Voltage Power Cables
- Control and Instrumentation Cables

Cable ladder shall be earthed at each end.

Metallic trefoil cable clamps and armoured cable glands shall be solidly earthed.

1.20.6 Earth Bonding

Metallic parts shall be bonded to the electrical earthing installation as per the requirements of SANS 10142-1.

Equipotential bonding shall be realised by means of connecting all metallic parts of the installation that is not intended to be live. This includes the earthing and bonding of basins, taps, waste pipes,

gutters, down pipes, stair railings, gates, fences, cables, wire ways etc. and shall be in accordance with the regulations and codes of practice.

Cable bridges, pipe rack frames, steelwork of buildings and structures shall be solidly connected to earth.

1.20.7 Substation Earth Bar

A 600mm long 40 * 6,3 mm earth bar, mounted on stand-off insulators shall be supplied and installed in the MCC in the position as indicated on the drawings. The **earth bar** shall be pre-drilled with 15 holes (9mm Ø) and M8 * 40 high tensile galvanised bolts with two flat washers, one spring washers and one nut per bolt. All bolts, nuts and washers shall be galvanised. The earth bar shall be complete with a single disconnection link to isolate the earth electrode for testing purposes.

A lightning protection installation in compliance with SANS 10313 and SANS / IEC 62305 parts 1, 2 and 3 shall be supplied and installed. The installation shall comply with the layout and detail drawings.

1.20.8 Lightning Protection of Structures

The external lightning protection installation shall comprise the following:

- A 70mm² bare copper earth wire ring conductor around the floor slab of structure as indicated on the drawings, 1 m outside the circumference and 500 mm below the finished ground level. This conductor shall be installed centre in a 100mm thick conductive concrete backfill at the bottom of the trench into which the ring conductor is installed.
- Conductive concrete made up from mixing Bentonite with the backfill material as per the recommendation of the Bentonite supplier.
- 16mm diameter round solid copper earth spikes, 1,8m long at each of the positions as indicated on the drawings. Should it not be possible to drive the earth spikes into the ground, a suitable borehole (minimum 80mm diameter) shall be drilled and the rod installed in a conductive concrete backfill in the hole.
- 70mm² black insulated copper conductors with lugs fitted to the studs on the structural steel columns of the buildings. The other end shall be connected to the earth spike and the ring earth electrode in a dedicated earth electrode connection box with lid to facilitate access to the system for maintenance purposes.
- Roof bonding conductor (35mm² black insulated copper conductors) bonded to the roof sheeting and lugged to the top of the structural steel columns.

The Contractor is referred to the drawings for more detail on the above system.

On completion of the installation, the Contractor shall survey the earth resistance of the complete system and submit a report to the Engineer.

The Contactor shall complete and submit a Lighting Protection System Installation Safety Report using the pro-forma as bound in as Annex A of SANS 10313:2010.

1.20.9 Instrumentation Bonding and Earthing

The instrumentation ground shall be connected to an isolated ground bar, which shall be bonded to the main ground bar at a single point.

All instruments, relays and meter enclosures in a control panel shall be effectively bonded to the panel frame.

The panel frame shall be provided with grounding lugs for connection to the Owner's ground system.

Where a control transformer is used, one side of the secondary winding shall be grounded.

Bonding cables must be provided where electrical or instrumentation components are not mounted on metal frames welded to the equipment or skid base.

All motor frames and process area electrical equipment shall be visibly grounded.

All process equipment subject to hazardous static voltage charges shall be permanently grounded such that all potential static voltage charges will be discharged to ground.

The screen of an instrumentation cable shall only be earth at one point.

1.21 FIRE EXTINGUISHERS

1.21.1 Aerosol Fire Suppression System

The PowerHub 120 is equipped with an aerosol fire suppression system.

1.21.2 Fire Suppression Water Pipe System

The PowerHub 120 is equipped with red thermosensitive glass balls, which explode at 68°C to spray water and cool the BESS.

1.22 PV SOLAR

The following specifications apply to the PV Inverter and Battery installation, the PV Solar panel installation as well as all the DC cabling and distribution on site.

1.22.1 Tariff Information

The site is classified under the Langeberg Local Municipality's Agricultural Consumer Tariff structure, billed as a Large Power User with an 11 kV connection at the Rural ≤100 kVA rate.

1.22.2 PV Array Field

The field indicated on the site overall electrical layout drawing shall be used for the installation of the PV array. The Contractor is responsible for ensuring that the ground-mounted support structure is designed and constructed to adequately support the PV panels, and that the structure is reviewed and signed off by a qualified structural engineer (Pr. Eng).

1.22.3 Compliance with Regulations

The installation must comply with various regulations and standards, including but not limited to:

- The Occupational Health and Safety Act 85 of 1993 and incorporated regulations.
- The local Municipal by-laws and regulations as well as the regulations of the local Supply Authority.
- The local Fire Regulations.
- The Standard Regulations of any applicable Government Department or public service company, such as Telkom or Neotel.
- All regulations and standards specified in the scope of works.
- IEC 60364-7-712.

The PV Specialist Contractor must provide all necessary drawings and notices for modifications to the local authorities at their own cost and must indemnify and exempt the Employer/Client from any losses, costs, or expenditures resulting from the PV Specialist Contractor's failure to comply with the above regulations. The PV Specialist Contractor may not begin work until relevant drawings or applications have been approved by the local authority and/or the Engineer.

The PV Specialist Contractor shall liaise with Eskom and/or local municipality to ensure that the system is designed, installed and commissioned in accordance with their requirements and ensure that the necessary arrangements are in place for connection to and operation in parallel with the utility supply.

It is assumed that the PV Specialist Contractor is familiar with these requirements. If any new requirements contradict this document, the PV Specialist Contractor must immediately inform the Employer, and may not make any changes without the written permission of the Employer.

1.22.4 Scope of Works

The PV arrays are expected to deliver an output as specified in the SLD & Layout drawings and operate as a grid-tied hybrid system with battery backup and communication and display elements. The system will work in parallel with the electrical supply from Langeberg Municipality. Any excess solar electricity will be exported to the supply authority.

The PV Specialist Contractor is responsible for submitting the required application to the supply authority and ensuring that the installed system adheres to their standards and specifications. The complete system, including the equipment and installation, must comply with the Occupational Health and Safety Act and its associated regulations.

The PV Specialist Contractor shall liaise with the Electrical Contractor in conjunction with the LV switchboard manufacturer to ensure that the correct equipment is installed and coordinated in accordance with their requirements.

Also, the systems and their components shall be manufactured and designed to the appropriate standards, including but not limited to:

- 1. SANS 10142 Part 1, Wiring of Premises – Electrical Installations.
- 2. SANS 10142 Part 3, Wiring of Premises – Embedded Generation.
- 3. SANS 10142 Part 5, Wiring of Premises – Direct Current and Photovoltaic.
- 4. NRS 097-2-1 (Part 2: Small Scale Embedded Generation, Section 1).
- 5. NRS 097-2-2.
- 6. NRS 097-2-3 (Part 2: Small Scale Embedded Generation, Section 3).
- 7. Eskom Guidelines for Embedded Generation.
- 8. NERSA Regulatory Framework on Small Scale Embedded Generation.
- 9. IEC 61215.

1.22.5 System Modules

PV array: Modules of poly-crystalline, positively sorted, minimum 20-year manufacturer warranty, sized to meet the specified system output requirements. Each array shall be supplied with a suitably sized disconnect switch to be approved by the engineer.

PV array support structure: The Contractor shall supply and install all ground-mounted support framework required for the system. The support structure design, including foundation requirements, loading, and layout, shall be coordinated with the structural drawings. The structure shall be designed, constructed, and signed off by a qualified structural engineer (Pr. Eng) in accordance with all applicable standards. The Contractor shall ensure adequate access is provided around and within the array for safe operation and maintenance of the PV panels.

Modular grid-tie inverter: Three (3)-phase grid-tie inverters which comply with all local and national by-laws about PV grid-tie systems shall be used. An isolated connection point shall be provided by the Electrical Contractor. The inverters shall be installed in a location set out by the Client or as indicated by the electrical engineer or architect.

Batteries: The batteries shall be protected by over charge and discharge protection. The batteries shall be easily isolated by means of a disconnection switch. The batteries shall have a minimum service lifetime of 10 years. The voltage of the batteries shall be compatible with the inverter voltage. The inverters shall have an approved charging mode for the selected batteries, as set out by the battery manufacturers. The batteries shall be mounted securely and in an area that will ensure the batteries are not at risk of mechanical damage.

MPPT: Inverters must have Maximum Power Point Tracking (MPPT) to optimize power. They must also be compatible with the manufacturer's specifications. The solar strings shall be configured to match the inverter MPPT range as close as possible.

Communication: Inverters should be connected to a data acquisition and control unit for local monitoring and adjustment. Both the Client and Engineer should have access to the recorded data via the data collection portal.

Metering: Meter interfaces should be installed with the main building meter for monitoring purposes.

1.22.6 PV Modules & Frames

The PV Modules shall comply with international standard IEC 61215 and carry a CE mark. The modules shall be installed on purpose-made support frames to ensure that the modules are inclined at the optimum tilt to maximize their output over the course of a year. The frames shall be constructed and secured to meet the required environmental conditions and aesthetic standards for ground-mounting. The fasteners used must be protected against galvanic rust/corrosion.

The frames holding the PV modules shall be bonded to the lightning protection system by the Lightning Protection Contractor. PV Specialist Contractor shall liaise with the lightning protection specialist to ensure that adequate connection points are available to ensure that the lightning protection system conforms with SANS or IEC 62305.

1.22.7 DC Cabling

The PV modules will be connected to the inverters using purpose-designed DC cables, which will be wired in strings. These cables will consist of 80°C photovoltaic cables with PV plug and socket connectors, designed to withstand UV radiation (UV Stabilised) and water exposure, and will be multi-stranded to allow for thermal and wind movement of the arrays/modules. The cables will be suitable for buried installation in sleeves.

The DC elements (wiring, connectors, etc.) will be sized to suit the maximum voltage and current of the PV arrays and individual modules, considering the system voltage/currents of the series/parallel connected modules that make up the array. Standard de-rating factors, such as temperature and solar gain grouping, will be applied in accordance with SANS 10142 part 1.

The DC elements of the PV system will incorporate Class II insulation (double insulation) to provide an extra layer of protection. DC junction boxes with negative and positive parts will be separated and protected by barriers, or by using separate enclosures. The cable runs will be kept as short as possible, and labels will be installed along the DC cables, indicating "Danger solar PV array cable – high voltage DC - live during daylight" as well as the string demarcations.

All necessary containment as set out in the cable specification section will be used to contain the DC cabling in accordance with SANS 10142.

1.22.8 DC Switches

DC isolation switches shall be installed to provide a means of manually isolating each PV string. The switches shall be located adjacent to or integrated into the associated inverters.

The switches shall be double poled and suitable for DC operation (load-break rated) to effectively isolate both PV string positive and negative poles. The DC switches shall be rated for the maximum system voltage and current.

The DC switches shall be labelled according to their respective PV strings, with the ON and OFF positions clearly marked. The enclosures shall also be labelled with "Danger - contains live parts during daylight".

1.22.9 Inverters

Hybrid inverters are the preferred solution for this project. Should the contractor wish to deviate from using hybrid inverters, it must be approved by the engineer before proceeding.

The inverters shall be capable of withstanding the maximum array voltage and current they may encounter, ensuring reliable and safe operation of the system.

The inverters shall carry an IEC Type Test certificate, or an approval from a recognized approval body that has been approved by the Engineer in writing, or meet the specific requirements defined by the Engineer.

The inverters shall be installed in IP 65 rated enclosures where applicable that offer suitable protection against the environmental conditions of the installation site and shall be mounted in a way that facilitates easy access for maintenance purposes. The inverters shall also be mounted in such a way to facilitate adequate air flow for cooling. The inverter mounting tolerances will be strictly followed as set out by the manufacturer.

The inverters shall automatically disconnect them from the LV distribution system in the event of a mains outage, to prevent the photovoltaic systems from working in island mode. The inverters will also comply with local grid codes.

The front of the inverter enclosures shall be labelled with the following sign: "Inverter - isolate AC and DC before carrying out work".

AC disconnecting devices will be mounted adjacent to the inverters and be rated for the maximum voltage and current of the inverter.

1.22.10 *Metering*

The PV Specialist Contractor is responsible for providing any approved export meters to the Electrical Contractor for installation into the main LV Switchboard. These meters must be capable of measuring and recording both the kWh and instantaneous power output (kW) of the system. The meters should be installed in a manner that allows for clear display and recording of the energy delivered by the PV system. The entire metering system must comply with all relevant local supply authority requirements and specifications.

1.22.11 *Operation and Maintenance Manuals*

The Operation and Maintenance Manuals (O&Ms) shall also include the following specific information for the PV installation:

- Basic system information.
- Single line electrical system schematic.
- Manuals, data sheets and other relevant product documentation for the system components.
- Copy of the test & commissioning documentation.
- Table of inverter protection settings (under/over voltage, under/over frequency, etc).
- Procedures for verifying correct system operation.
- A checklist of what procedures to undertake in case of a system failure.
- Shutdown/isolation and start up procedures.
- Maintenance & cleaning recommendations (if any).
- Considerations for any future building works adjacent to the PV array (e.g., roof works) to avoid potential damage or shading of the PV array.
- Warranty Information.

1.22.12 *Communication Modules*

The PV Specialist Contractor is responsible for installing a suitable communication protocol on site for the inverters to communicate with each other as well as any relevant existing client equipment (e.g., SCADA, Generator Controllers, BMS). The switches, controllers and network cabling will be performed by the PV contractor where necessary. Communication must preferably be via mobile network.

1.23 AS BUILT DOCUMENTATION AND PROJECT CLOSE OUT PROCEDURE

As built drawings of the installation of the installation shall be compiled according to the following procedure:

One set of the Engineers drawings will be supplied to the Contractor. The Contractor shall then:

- (1) Update the drawings so that they coincide with the actual installation on site.
- (2) Return the marked up drawings to the Engineer, in order that the Engineer may update CAD drawings.
- (3) The Engineer will then issue the As Built Drawings to the Client.

The following documentation shall be provided in triplicate on completion of the project in a binder file entitled as "ELECTRICAL INSTALLATION – VALIDATION DOCUMENTATION"

- (1) Complete set of "As Built" drawings,
- (2) **Technical** information brochures on **all** equipment used. Generalised sales brochures will not be acceptable and the information must be specific to the equipment installed,
- (3) Operating procedures,
- (4) Adjustment settings and calculations of settings of equipment with adjustable operators,
- (5) Results listings of all commissioning tests performed including data of measurement techniques used, serial numbers of instruments and copies of calibration certificates of all instruments used. The listings must be in such a format that the tests can be repeated at any time in future and the results compared with the initial commissioning data.
- (6) Maintenance procedures and schedules, and
- (7) List of recommended spare parts.

The final claim for payment will not be processed unless the above information has been submitted to the satisfaction of the Engineer and Client.

1.23.1 MAINTENANCE AND REPAIR DURING THE 12 MONTH DEFECTS LIABILITY PERIOD

The equipment and installation supplied under this contract shall be guaranteed and maintained for a period of twelve months from date of acceptance by the Engineer in all respects and commissioned for continuous service. The tender price shall include for the above.

1.23.2 REPAIR DURING THE 12 MONTH DEFECTS LIABILITY PERIOD

The defects liability period will be for a period of twelve months, calculated from the date of issue of the Certificate of Completion by the Engineer. Retention funds will be reduced to 2,5% upon commencement of the defects liability period. The balance of the retention money will be paid out

after lapse of the defects liability, provided the installation has, in the opinion of the Engineer, been in satisfactory working order during this period.

The Contractor shall be responsible for the replacement of all faulty equipment, including blown or faulty lamps during the defects liability period.

Faulty equipment shall be attended to immediately, irrespective of the scheduled date of the next maintenance visit, and shall be replaced or repaired within 3 working days of being instructed by the Engineer.

All repairs shall commence within 24 hours of written or verbal advice by the Engineer. Advice by facsimile or e-mail shall be in writing. Should the Contractor fail to commence repairs to the faulty installation within 24 hours from the time of notification, the repair work may be carried out by others and the costs thereof deducted from the funds held in retention.

All repairs shall be carried out to the satisfaction of the Engineer. All labour, material and infrastructure costs incurred for the repair of faulty equipment shall be borne by the Contractor. No claims in this regard will be considered.

1.23.3 MAINTENANCE DURING THE 12 MONTHS DEFECTS LIABILITY PERIOD

The Contractor shall allow for 1 monthly scheduled maintenance visit during the 12 months defects liability period to attend to preventative maintenance of the installation. Details of each visit, undersigned by the Client's authorised representative shall be submitted to the Engineer as proof of the required visits in order that retention funds may be released at the expiry of the 12 month period.

All labour, material and infrastructure costs incurred for the repair of faulty equipment shall be borne by the Contractor. No claims in this regard will be considered.

2. PREFERRED EQUIPMENT SUPPLIERS

2.1 PREFERRED ELECTRICAL EQUIPMENT SUPPLIERS

Equipment Type	Preferred Supplier 1	Preferred Supplier 2	Preferred Supplier 3
LV Switchgear	ABB	Schneider	CBI

2.2 TENDER DOCUMENTATION REQUIREMENTS

The Tenderer shall supply the following documentation during the different project phases as indicated in the table below. The timing of the documents to be provided shall be as follows:

- **X** = Submit for Sign-Off by Engineer before proceeding with procurement of materials.
- **i** = Submit for Information only.
- **C** = Submit as part of Close-Out documentation

General Notes:

- (1) Documentation shall be submitted in electronic format (PDF).
- (2) Documentation shall be in English

Item	Description	Bid	After Contract Award						Close-Out	
			Supplier Data Sheets	Supplier Data Sheets	Quality Assurance Plan	Assemble / Shop Drawings	Wiring Diagrams	Recommended Spares	Testing Certificates	Operation & Maintenance Documentation.
1	Cabling (MV, LV, Instrument, Control, Network, Fire)	-	X	-	-	-	-	-	-	-
2	LV Distribution Board	-	X	-	X	X	C	C	C	C
3	Inverter(s)	i	X	-	X	-	-	C	C	-
4	Solar Panels	i	X	-	-	-	-	C	C	-
5	BESS (Battery Energy Storage System)	i	X	-	-	-	-	C	C	-

3. DRAWINGS & DOCUMENTS

The following drawings and documents (not bound in but issues separately) form part of the Electrical Installation Tender document.

Table III: Drawings & Documents

Document Description	Document Number
Site Overall Electrical Layout	CT0479-EL-LAY-0001
Site Overall Single Line Diagram	CT0479-EL-SLD-0001
Minisub General Arrangement 3D	CT0479-EL-GAR-0001
PV Solar General Arrangement	CT0479-EL-GAR-0002
PV Solar Array Layout	CT0479-EL-LAY-0002
Typical Minisub General Layout	CT0479-EL-LAY-0003
PV Solar Module Stringing Designation	CT0479-EL-LST-0001
Cable List	CT0479-EL-LST-0002

4. BILLS OF QUANTITIES

4.1 GENERAL

The Conditions of Tender, General Conditions of Contract, the Special Conditions of Contract, the Specifications (including the Project Specification) and the Drawings are to be read in conjunction with the Bills of Quantities.

The general requirements and descriptions of the Works and materials given in the Specifications are not repeated in the Bills of Quantities and Tenderers shall refer to the other parts of the Documents for this information.

The cost of complying with all conditions, obligations and liabilities specified in the Conditions of Tender, General Conditions of Contract, Special Conditions of Contract, Specifications and Bills of Quantities, including all overhead charges and profit, and the cost of carrying out the work as shown on the Drawings, shall be deemed to be included in the rates and sums quoted in the Bills of Quantities.

4.2 DESCRIPTION OF ITEMS IN THE BILLS

The Bill comprises items covering the Contractor's profit and costs of general liabilities and of the construction of temporary and permanent Works.

4.3 QUANTITIES REFLECTED IN THE BILLS

The quantities of work and material set forth in the Bills of Quantities are estimates only, and shall not be considered as limiting or extending the amount of work to be done and material to be supplied by the Contractor, nor shall these quantities be regarded as constituting authority to the Contractor to order material or to execute work. The Contractor shall obtain the Engineer's detailed instructions for all work before ordering any materials or executing work or making arrangements for it. The Works as finally completed in accordance with the Contract shall be measured and paid for as specified in the Bills of Quantities and in accordance with the General Conditions of Contract, the Special Conditions of Contract, the Specifications and the Drawings. Unless otherwise stated, items are measured net in accordance with the Drawings, and no allowance has been made for waste.

4.4 PRICING OF THE BILLS OF QUANTITIES

The prices and rates to be inserted in the Bills of Quantities are to be the full inclusive prices to the Employer for the work described under the several items. Such rates and prices shall cover all costs and expenses that may be required in and for the construction of the work described, and shall cover the cost of all general risks, liabilities, and obligations set forth or implied in the documents on which the Tender is based (excluding Value added Tax (VAT)). VAT shall be added at the end of the summary of the Bills of Quantities as indicated.

The Tenderer is at liberty to insert a rate of his own choosing for each item in the Bills and his attention is drawn to the fact that the Contractor has the right, under various circumstances, to payment for additional Works carried out and that the Engineer is obliged to base his assessment of the rates to be paid for such additional work on the rates inserted in the Bills by the Contractor.

If the Contractor omits to price any items in the Bills of Quantities, then these items will be considered to have a nil rate or price.

All items for which terminology such as "inclusive" or "not applicable" have been added by the Tenderer will be regarded as having a nil rate, and shall be valid irrespective of any change in quantities during the execution of the Contract.

The Tenderer shall fill in rates for all items where the words "rate only" appear in the "Amount" column. The intention is that although no work is foreseen under such an item, and no quantities are accordingly given in the "Quantity" column, the quoted rate shall apply in the event of work under this item being actually required.

The Tenderer shall price each item in the Bills of Quantities in black ink.

All rates and amounts quoted in the Bills of Quantities shall be in South African Rand.

The bill for preliminary and general items shall be priced for the three phases in total. Payment against these items, however, shall only be certified according to the pro-rata value of the three individual phases of the work as executed.

4.5 BILLS OF QUANTITIES

The following Bills of Quantities (not bound in but issued separately) form part of the Electrical Installation Tender document.

See Attached Electrical Bills of Quantities: **Document CT0479-EL-BOQ-0001**

-----End of document-----

C4 . 4

ANNEXURE C
DRAWINGS



LEGEND

- DISTRIBUTION BOARD
- DC TO AC INVERTER
- PV SOLAR PANEL (2384x1136mm)
- 800x400mm (DEPTH x WIDTH) TRENCH WITH 75mm Ø CLASS 6 FLEXIBLE SLEEVE
- 2.2m HIGH CLEARVU FENCE TOPPED WITH 6-STRAND ELECTRIC FENCING
- CONTRACTOR WORKING AREA
- CONTRACTOR ACCESS ROUTE

PROJECT NOTES

1. HYBRID INVERTER & BATTERIES TO BE INSTALLED UNDER A COVERED STRUCTURE. THE INVERTER & BATTERY COMBO SHALL BE EQUAL OR SIMILAR TO THE **SUNSYNK POWERHUB 120**. THE STRUCTURE SHALL PROMOTE EASY ACCESS TO THE BATTERIES & INVERTER FOR MAINTENANCE.
2. CABLE SLEEVES SHALL BE CONCEALED IN THE GROUND AS FAR AS POSSIBLE. THE SLEEVE ROUTE SHALL BE CHOSEN TO MINIMIZE TRENCHING.

GENERAL NOTES

1. CONTRACTOR TO ENTER AND EXIT THE SITE AT INDICATED ACCESS FROM LANGVERWAGTEN RD.
2. CONTRACTOR TO MAKE USE OF EXISTING ROADS TO REACH AREAS WITHIN THE SCOPE OF WORK.
3. THE CONTRACTOR SCOPE OF WORK DEMARCATION INDICATES THE LOCATIONS WHERE THE CONTRACTOR MAY TRAVERSE WITHOUT ADDITIONAL PERMISSION FROM THE ENGINEER AND/OR CLIENT.

REV	DATE	DESCRIPTION	BY
0	27 MAY 2026	FOR TENDER	PF

BCE BÜHRMANN
CONSULTING ENGINEERS

Unit 25, Muirfield House, Midpark Business Village,
2 Greens Close, Parow, 7500, South Africa
t +27(0) 21 930 4934 f +27(0) 84 440 9273
info@buhmannce.co.za | www.buhmannce.co.za



PRINCIPAL AGENT:
BUHRMANN CONSULTING ENGINEERS

PROJECT:
VROLIJKHEID SOLAR

TITLE:
SITE OVERALL ELECTRICAL LAYOUT

FOR TENDER

DESIGNED:	P FOURIE	CHECKED:	B HUMAN
DRAWN:	P FOURIE	SCALE:	1:900 (A1)
DRAWING NO:	CT0479-EL-LAY-0001		REV: 0

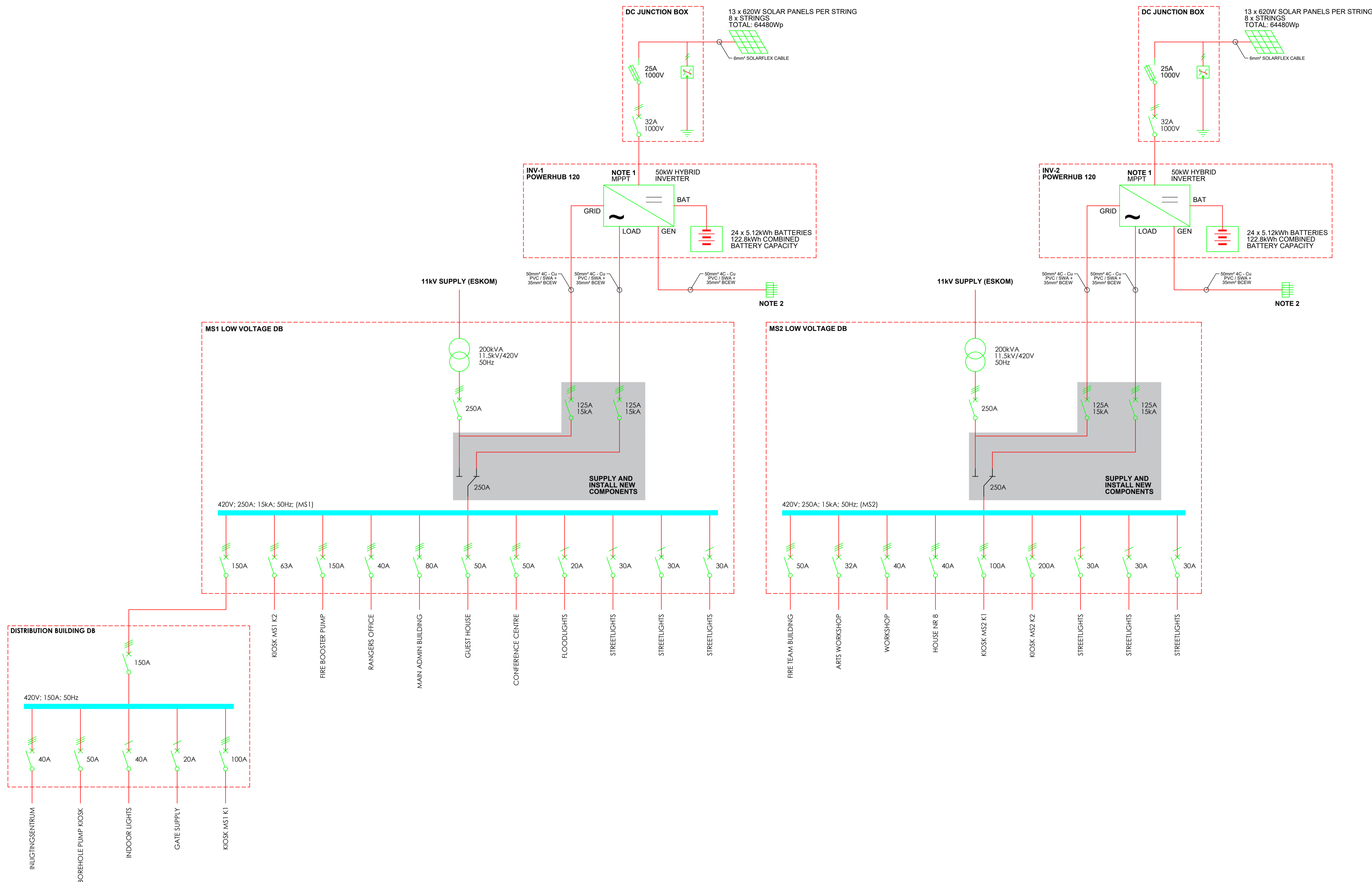

LEGEND

- SURGE ARRESTOR (TVVS)
- PV SOLAR STRING(S)
- BATTERY
- HYBRID INVERTER WITH MPPT BUILT-IN
- CIRCUIT BREAKER
- FUSE
- BREAK-BEFORE-MAKE CHANGEOVER SWITCH
- 3P+N+PE STRAIGHT INDUSTRIAL POWER CONNECTOR FOR GENERATOR INPUT

- ### GENERAL NOTES
- THE INVERTER HAS 4 MPPT INPUTS. EACH MPPT WILL HAVE 2 STRINGS CONNECTED TO IT. EACH CONNECTION WILL BE ROUTED THROUGH A JUNCTION BOX IN SERIES WITH A DEDICATED FUSE AND CIRCUIT BREAKER.
 - 5 PIN (3P+N+PE) STRAIGHT INDUSTRIAL POWER CONNECTOR FOR GENERATOR INPUT, RATED FOR 125A AND 400V. THE CONNECTOR WILL BE POLE-MOUNTED UNDER THE INVERTER & BATTERY COVER STRUCTURE.

0	27 MAY 2026	FOR TENDER	PF
REV	DATE	DESCRIPTION	BY

BCE BÜHRMANN
CONSULTING ENGINEERS
Unit 25, Muirfield House, Midpark Business Village,
2 Greens Close, Parow, 7500, South Africa
t +27(0) 21 930 4934 | m +27(0) 84 440 9273
info@buhrmannce.co.za | www.buhrmannce.co.za

CLIENT:

PRINCIPAL AGENT:
BUHRMANN CONSULTING ENGINEERS

PROJECT:
VROLIJKHEID SOLAR

TITLE:
SITE OVERALL SINGLE LINE DIAGRAM

FOR TENDER

DESIGNED:	P FOURE	CHECKED:	B HUMAN
DRAWN:	P FOURE	SCALE:	NTS (A1)
DRAWING NO:	CT0479-EL-SLD-0001		REV: 0



LEGEND

PROJECT NOTES

1. HYBRID INVERTER & BATTERIES TO BE INSTALLED UNDER A COVERED STRUCTURE. THE INVERTER & BATTERY COMBO SHALL BE EQUAL OR SIMILAR TO THE **SUNSYNK POWERHUB 120**. THE STRUCTURE SHALL PROMOTE EASY ACCESS TO THE BATTERIES & INVERTER FOR MAINTENANCE.
2. CABLE SLEEVE SHALL BE CONCEALED IN THE GROUND AS FAR AS POSSIBLE. THE SLEEVE ROUTE SHALL BE CHOSEN TO MINIMIZE TRENCHING.

REV	DATE	DESCRIPTION	BY
0	27 MAY 2026	FOR TENDER	GW8

BCE BÜHRMANN
CONSULTING ENGINEERS
Unit 25, Muirfield House, Midpark Business Village,
2 Greens Close, Parow, 7500, South Africa
t +27(0) 21 930 4934 | m +27(0) 84 440 9273
info@buhmannce.co.za | www.buhmannce.co.za

CLIENT:

PRINCIPAL AGENT:
BUHRMANN CONSULTING ENGINEERS

PROJECT:
VROLIJKHEID SOLAR

TITLE:
MINISUB GENRAL ARRANGEMENT 3D

FOR TENDER

DESIGNED:	GW8	CHECKED:	BH
DRAWN:	GW8	SCALE:	NTS (A1)
DRAWING NO:	CT0479-EL-GAR-0001		REV:
			0

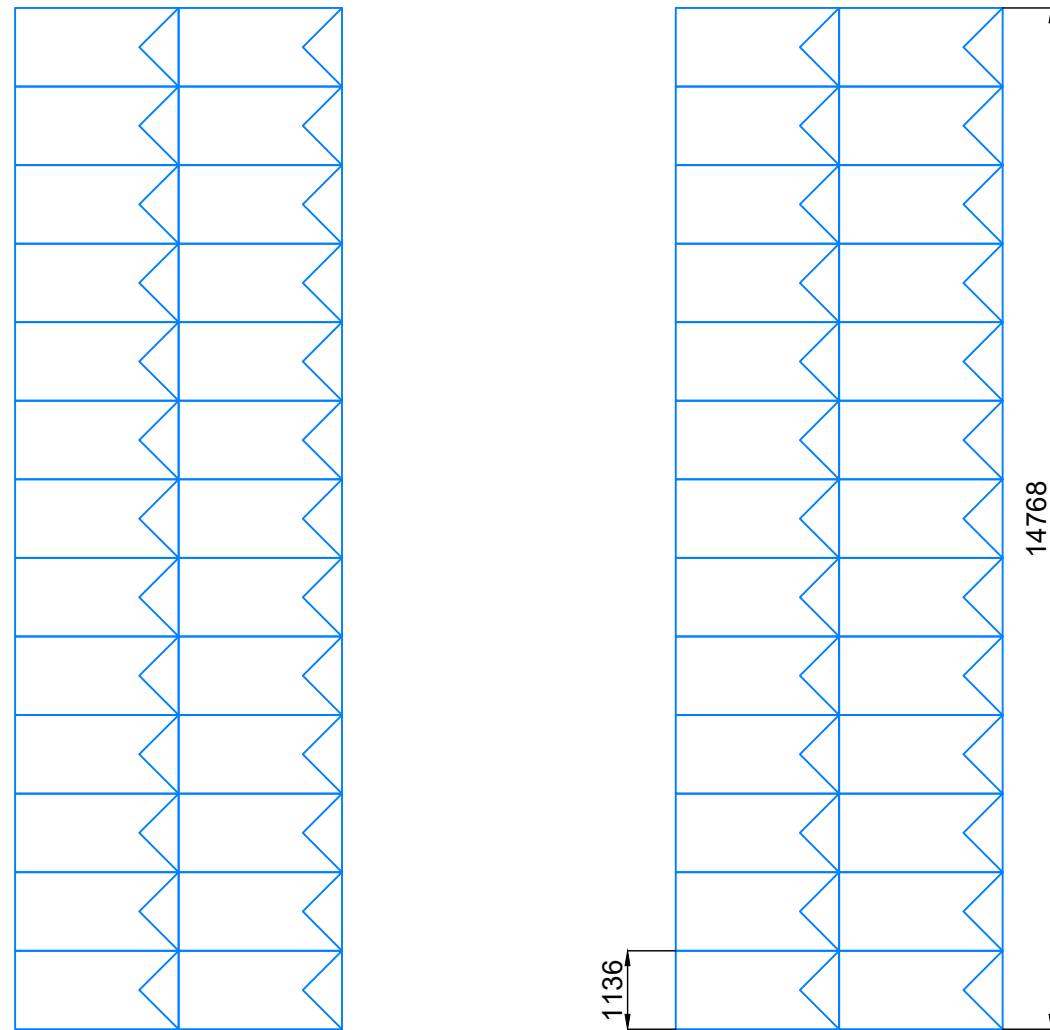

TOP VIEW

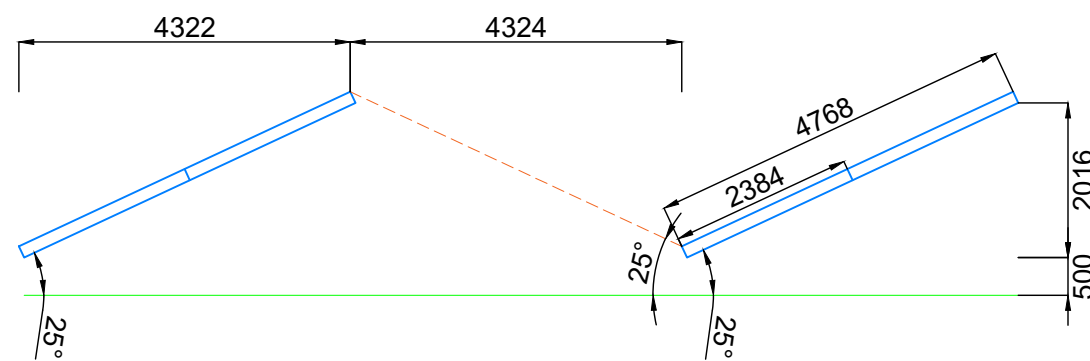

SIDE VIEW



LEGEND

-  PV SOLAR PANEL (2384x1136mm)
-  GROUND LEVEL
-  SUN INCIDENT ANGLE

GENERAL NOTES

1. ALL PV MOUNTING STRUCTURES SHALL BE ENGINEERED, DESIGNED AND SIGNED OFF BY A REGISTERED STRUCTURAL ENGINEER (PR ENG) IN ACCORDANCE WITH THE REQUIREMENTS OF SANS 10160 (STRUCTURAL DESIGN AND ACTIONS – INCLUDING WIND ACTIONS), TOGETHER WITH ALL OTHER APPLICABLE STANDARDS SUCH AS SANS 10162 (STRUCTURAL STEEL DESIGN) AND SANS 10100 (CONCRETE WORKS) WHERE RELEVANT.

REV	DATE	DESCRIPTION	BY
0	27 MAY 2026	FOR TENDER	PF

BCE BÜHRMANN
CONSULTING ENGINEERS
Unit 25, Muirfield House, Midpark Business Village,
2 Greens Close, Parow, 7500, South Africa
t +27(0) 21 930 4934 | m +27(0) 84 440 9273
info@buhmannce.co.za | www.buhmannce.co.za

CLIENT:

PRINCIPAL AGENT:
BUHRMANN CONSULTING ENGINEERS

PROJECT:
VROLIJKHEID SOLAR







TITLE:
PV SOLAR GENERAL ARRANGEMENT

FOR TENDER

DESIGNED:	P FOUR	CHECKED:	B HUMAN
DRAWN:	P FOUR	SCALE:	NTS (A3)

DRAWING NO: **CT0479-EL-GAR-0001** REV: **0**

LEGEND

-  PV SOLAR PANEL
-  JUNCTION BOX
-  800x400mm (DEPTH x WIDTH) TRENCH WITH 75mm Ø CLASS 6 FLEXIBLE SLEEVE
-  P8000 TRUNKING
-  2.2m HIGH CLEARVU FENCE TOPPED WITH 6-STRAND ELECTRIC FENCING
-  2.2m HIGH TRACK-MOUNTED SLIDING GATE TOPPED WITH 6-STRAND ELECTRIC FENCING

GENERAL NOTES

1. PV ARRAY TO BE GROUND-MOUNTED NO LOWER THAN 0.5m FROM THE GROUND.
2. PV PANELS TO BE RETICULATED TO INVERTER ENCLOSURE VIA TRENCH IN BURIED FLEXIBLE SLEEVE.
3. 2.2m HIGH CLEARVU FENCE TOPPED WITH 6-STRAND ELECTRIC FENCE TO BE INSTALLED AROUND PV ARRAY TO PROTECT FROM THEFT AND DAMAGE FROM BABOONS.
4. 2.2m HIGH TRACK-MOUNTED SLIDING GATE TOPPED WITH 6-STRAND ELECTRIC FENCE TO BE INSTALLED FOR MAINTENANCE ACCESS.

REV	DATE	DESCRIPTION	BY
0	27 MAY 2026	FOR TENDER	PF

BCE BÜHRMANN
CONSULTING ENGINEERS
Unit 25, Muirfield House, Midpark Business Village,
2 Greens Close, Parow, 7500, South Africa
t +27(0) 21 930 4934 | m +27(0) 84 440 9273
info@buhmannce.co.za | www.buhmannce.co.za

CLIENT:

PRINCIPAL AGENT:
BUHRMANN CONSULTING ENGINEERS

PROJECT:
VROLIJKHEID SOLAR

TITLE:
PV SOLAR ARRAY LAYOUT

FOR TENDER

DESIGNED:	P FOURIE	CHECKED:	B HUMAN
DRAWN:	P FOURIE	SCALE:	1:300 (A3)

DRAWING NO: **CT0479-EL-LAY-0002** REV: **0**

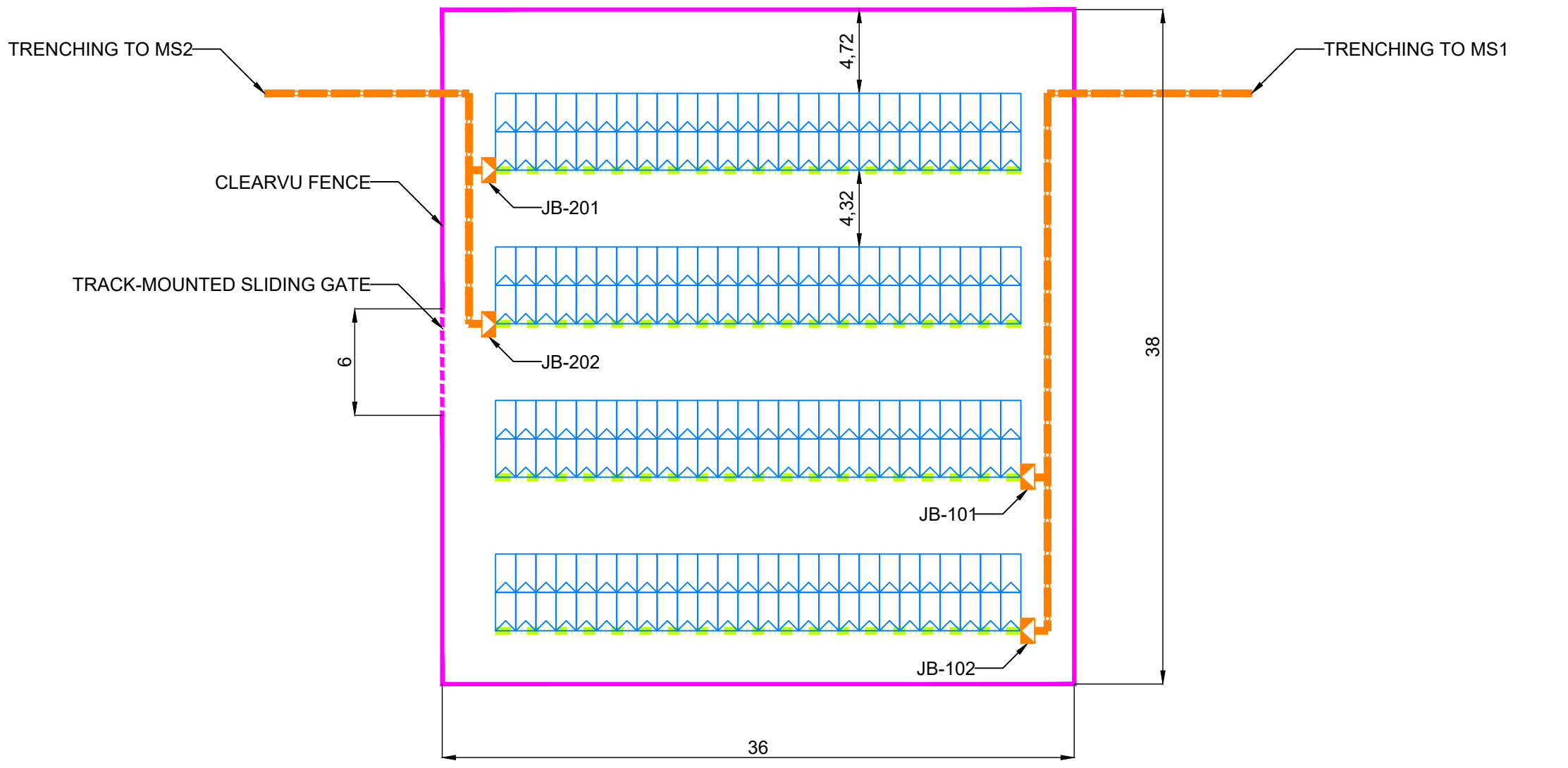

FRONT VIEW

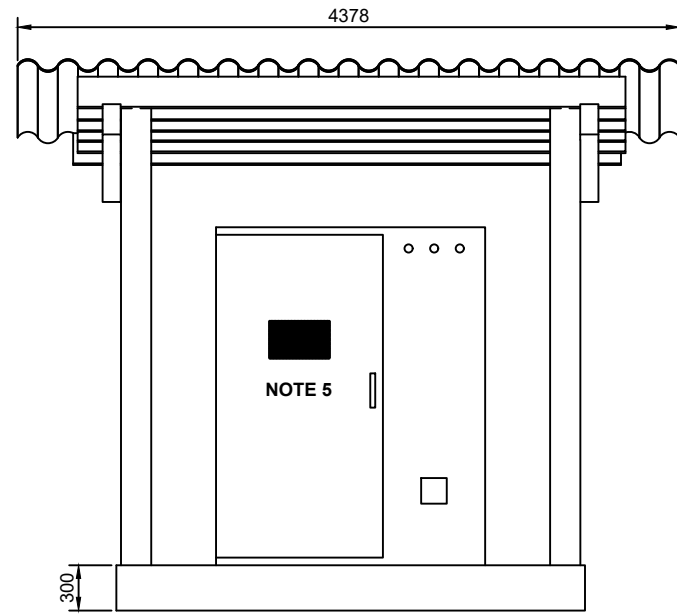

SIDE VIEW

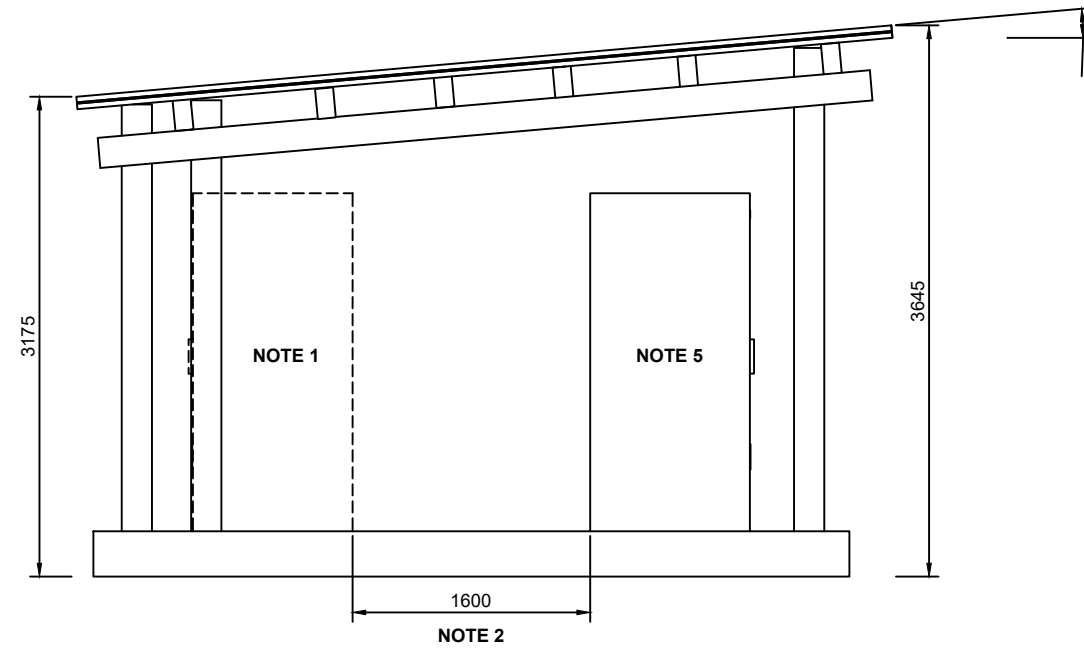

TOP VIEW

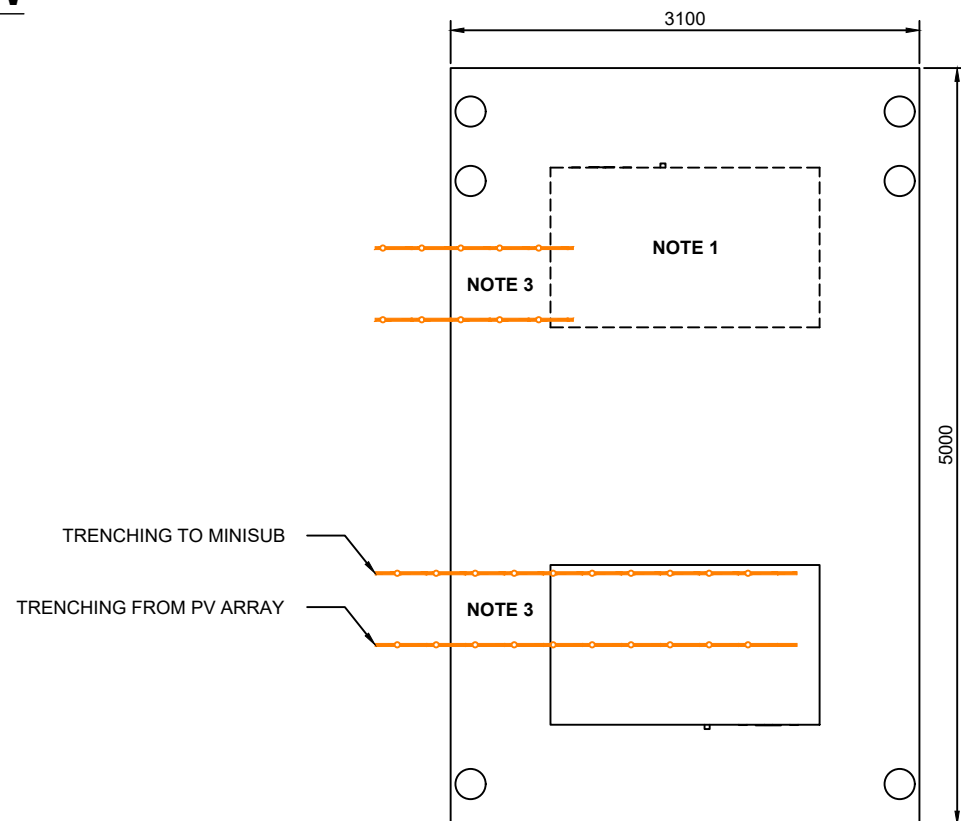

LEGEND

80x400mm [DEPTH x WIDTH] TRENCH WITH 75mm Ø CLASS 6 FLEXIBLE SLEEVE

GENERAL NOTES

- ADDITIONAL POWERHUB 120 INDICATED FOR FUTURE EXPANSION. CONTRACTOR TO ENSURE ALL REQUIRED CABLE SLEEVES ARE INSTALLED, POSITIONED CORRECTLY, AND SEALED UNTIL FUTURE USE.
- THE USER MANUAL OF THE SUNSYNK POWERHUB 120 SPECIFIES A MINIMUM SPACING OF 1600mm FOR BACK-TO-BACK INSTALLATIONS.
- CABLE SLEEVE POSITIONING TO BE CONFIRMED BY CONTRACTOR PRIOR TO PLINTH CONSTRUCTION.
- THIS DRAWING ARRANGEMENT APPLIES TO BOTH MS-1 AND MS-2.
- EXTERIOR PAINT COLOUR OF POWERHUB 120 TO BE OLIVE GREEN.
- ALL STRUCTURES SHALL BE ENGINEERED, DESIGNED AND SIGNED OFF BY A REGISTERED STRUCTURAL ENGINEER (OR ENG) IN ACCORDANCE WITH THE REQUIREMENTS OF SANS 10160 (STRUCTURAL DESIGN AND ACTIONS), TOGETHER WITH ALL OTHER APPLICABLE STANDARDS SUCH AS SANS 10162 (STRUCTURAL STEEL DESIGN) AND SANS 10100 (CONCRETE WORKS WHERE RELEVANT).

REV	DATE	DESCRIPTION	BY
0	27 MAY 26	FOR TENDER	PF

BCE BÜHRMANN
CONSULTING ENGINEERS

Unit 25, Muirfield House, Midpark Business Village,
2 Greeris Close, Parow, 7500, South Africa
t +27(0) 21 930 4934 f +27(0) 84 440 9273
info@buhmannce.co.za | www.buhmannce.co.za

CLIENT:



PRINCIPAL AGENT:

BUHRMANN CONSULTING ENGINEERS

PROJECT:

VROLIJKHEID SOLAR

TITLE:

TYPICAL MINISUB GENERAL LAYOUT

FOR TENDER

DESIGNED:	P FOURIE	CHECKED:	B HUMAN
DRAWN:	P FOURIE	SCALE:	NTS (A3)
DRAWING NO:	CT0479-EL-LAY-0003		REV: 0



Project Name
VROLIJKHEID SOLAR

Project Number
CT0479

Document Title
PV SOLAR MODULE STRINGING DESIGNATION

Document Number
CT0479-EL-LST-0001-R0

0	15 May 26	Issue for Tender	P Fourie	B Human
Rev	Date	Description	Prepared	Approved
Document Control				
Consulting Engineer			Client	
 Unit 25, Midpark Business Village, 2 Greens Cl, Parow, 7506 t +27 (0) 21 930 4934 m +27 (0) 84 440 9273 info@buhrmannce.co.za www.buhrmannce.co.za			Cape Nature Conservation Board, PGWC Shared Services Centre, corner Bosduif and Volstruis streets, Bridgetown, Gatesville, 7766	



VROLIJKHEID SOLAR
PV SOLAR MODULE STRINGING
DESIGNATION
CT0479-EL-LST-0001-RO



No.	Inverter Number	String Number	MPPT Number	DC Input Terminal	Substation DC Joiner Box	Field DC Joiner Box	Module Size	Modules Per String	String Distance From Inverter (m)
1	INV-1	S101	1	PV1-1	INV-1	JB-101	620Wp (Bifacial)	13	95
2	INV-1	S102	1	PV1-2	INV-1	JB-101	620Wp (Bifacial)	13	95
3	INV-1	S103	2	PV2-1	INV-1	JB-101	620Wp (Bifacial)	13	105
4	INV-1	S104	2	PV2-2	INV-1	JB-101	620Wp (Bifacial)	13	105
5	INV-1	S105	3	PV3-1	INV-1	JB-102	620Wp (Bifacial)	13	105
6	INV-1	S106	3	PV3-2	INV-1	JB-102	620Wp (Bifacial)	13	105
7	INV-1	S107	4	PV4-1	INV-1	JB-102	620Wp (Bifacial)	13	115
8	INV-1	S108	4	PV4-2	INV-1	JB-102	620Wp (Bifacial)	13	115
9	INV-2	S201	1	PV1-1	INV-2	JB-201	620Wp (Bifacial)	13	170
10	INV-2	S202	1	PV1-2	INV-2	JB-201	620Wp (Bifacial)	13	170
11	INV-2	S203	2	PV2-1	INV-2	JB-201	620Wp (Bifacial)	13	180
12	INV-2	S204	2	PV2-2	INV-2	JB-201	620Wp (Bifacial)	13	180
13	INV-2	S205	3	PV3-1	INV-2	JB-202	620Wp (Bifacial)	13	180
14	INV-2	S206	3	PV3-2	INV-2	JB-202	620Wp (Bifacial)	13	180
15	INV-2	S207	4	PV4-1	INV-2	JB-202	620Wp (Bifacial)	13	190
16	INV-2	S208	4	PV4-2	INV-2	JB-202	620Wp (Bifacial)	13	190

Notes:

- 1) Cable lengths to be confirmed on site before ordering.



Project Name
VROLIJKHEID SOLAR

Project Number
CT0479

Document Title
CABLE LIST

Document Number
CT0479-EL-LST-0002-R0

0	13 May 26	Issue for Tender	P Fourie	B Human
Rev	Date	Description	Prepared	Approved

Document Control

Consulting Engineer	Client
<p>BCE BÜHRMANN <small>CONSULTING ENGINEERS</small></p> <p>Unit 25, Muirfield House, Midpark Business Village, 2 Greens Close, Parow, 7500, South Africa t +27 (0) 21 930 4934 m +27 (0) 84 440 9273 info@buhrmannce.co.za www.buhrmannce.co.za</p>	<p>Cape Nature Conservation Board, PGWC Shared Services Centre, corner Bosduif and Volstruis streets, Bridgetown, Gatesville, 7766</p>



VROLIJKHEID SOLAR
CT0479
CT0479-EL-LST-0002-R0



Cable Tag	From	To	Description	Conductor Type	Size (mm)	Cores	Cable Qty	Phases	Load (kW)	PF	Load (kVA)	Diversity	Div Load (kVA)	Voltage (V)	Load (A)	Breaker Size (A)	Length (m)
MS-1-TX/INV-1	MS-1-TX	INV-1	MS LV Transformer to Inverter Input	PVC SWA Cu	50	4	1	3	50,0	0,80	62,5	0,80	50,0	400	90,2	125	5
INV-1/MDB-1	INV-1	MDB-1	Inverter Output to MDB	PVC SWA Cu	50	4	1	3	50,0	0,80	62,5	0,80	50,0	400	90,2	125	5
INV-1/PPGEN-1	INV-1	PPGEN-1	Inverter GEN to 5-pin Generator Power Point	PVC SWA Cu	50	4	1	3	50,0	0,80	62,5	0,80	50,0	400	90,2	125	5
MS-2-TX/INV-2	MS-2-TX	INV-2	MS LV Transformer to Inverter Input	PVC SWA Cu	50	4	1	3	50,0	0,80	62,5	0,80	50,0	400	90,2	125	5
INV-2/MDB-2	INV-2	MDB-2	Inverter Output to MDB	PVC SWA Cu	50	4	1	3	50,0	0,80	62,5	0,80	50,0	400	90,2	125	5
INV-2/PPGEN-2	INV-2	PPGEN-2	Inverter GEN to 5-pin Generator Power Point	PVC SWA Cu	50	4	1	3	50,0	0,80	62,5	0,80	50,0	400	90,2	125	5

Notes:

- 1) Cable quantities to be confirmed on site before ordering.
- 2) Cable tags on site to contain the source and destination which needs to be on the supply and receiving side of the cable.
- 3) Earth cables are not shown on the cable list, but must be installed by the contractor.

C4.5

ANNEXURE D
ENVIRONMENTAL SPECIFICATION



Environmental Management Plan for Cederberg Wilderness Area

Generic CapeNature Construction EMP

Version: Jan 2013

ENVIRONMENTAL MANAGEMENT PLAN FOR [PLACE/PROJECT] – [DATE]

1. CONTENTS

Environmental Management Plan – Purpose.....2

PROCESS CHECKLIST **Error! Bookmark not defined.**

Identification of Environmental Risks and Mitigation Procedures18

Roles and Responsibilities – assigned staff4

Roles, Responsibilities and Contract Obligations - description6

ENVIRONMENTAL MANAGEMENT PROCEDURES AND ACTIVITIES11

 Restriction of Working Areas11

 Storage of construction material.....13

 Use of cement / concrete13

 Access11

 Oil Management.....14

 Bringing construction materials onto a nature reserve15

 Waste Management15

 Fires16

 Site Rehabilitation16

 Documentation16

 Contract Obligations.....17

ANNEXURE 1: Environmental Management Programme (EMP) – Audit Checklist.....22

ANNEXURE 2 - KEY Site Rules during construction28

ANNEXURE 3: National Environmental Management Act principles.....30

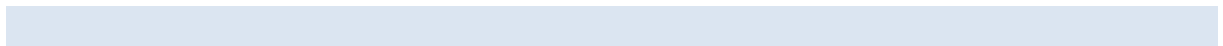

2. ENVIRONMENTAL MANAGEMENT PLAN – PURPOSE

The main purpose of an Environmental Management Programme (EMP) is to identify key environmental risks and prevent avoidable damage and/or minimise or mitigate unavoidable environmental damage associated with a construction, maintenance, or demolition project/works.

An EMP is required as part of the application process for any project triggering environmental authorisation, but must also be used for any project with risk of environmental harm in our protected areas.

The EMP forms part of the contractual obligations to which all contractors/employees involved in construction, maintenance, or demolition work must be committed.

This EMP:

- identifies important and sensitive environments near project site/s that could feasibly be affected by works;
- identifies project activities that could cause environmental damage (risks) and provides a summary of actions required;
- identifies persons responsible for ensuring compliance with the EMP and provides their contact information;
- provides standard procedures to avoid and/or minimise the identified negative environmental impacts and to enhance the positive impact of the project on the environment;
- provides site and project specific rules and actions required, including a site plan/s showing:
 - areas where construction, maintenance, or demolition work may be carried out;
 - areas where any material or waste may be stored;
 - allowed access routes, parking and turning areas for construction or construction related vehicles;
- forms a written record of procedures, responsibilities, requirements and rules for Contractor/s, their staff and any other person who must comply with the EMP;
- provides a monitoring and auditing programme to track and record compliance and identify and respond to any potential or actual negative environmental impacts; and
- provides a monitoring programme to record any mitigation measures that are implemented;

4. ROLES AND RESPONSIBILITIES – ASSIGNED STAFF

ROLE	PERSON, POSITION, COMPANY	DATE	SIGNATURE
	<i>CapeNature Construction Project Manager</i>		
	<i>CapeNature Environmental Specialist</i>		
	<i>Principal Agent</i>		
	<i>Environmental Control Officer ("ECO")</i>		
	<i>Contractor</i>		
	<i>Contractor</i>		
	<i>Contractor</i>		
	<i>Contractor</i>		

All parties signing here agree to be bound by the requirements of this EMP document, and to fulfil the obligations of their role as set out below.

Telephone (cel)	telephone (office)	email address	ROLE
			<i>CapeNature Construction Project Manager</i>
			<i>CapeNature Environmental Specialist</i>
			<i>Principal Agent</i>
			<i>Environmental Control Officer ("ECO")</i>
			<i>Contractor</i>
			<i>Contractor</i>
			<i>Contractor</i>
			<i>Contractor</i>

5. ROLES, RESPONSIBILITIES AND CONTRACT OBLIGATIONS - DESCRIPTION

As the client, CapeNature must take final responsibility for implementation of this EMP and its requirements including any environmental rehabilitation that may be needed. *This is mandated by Section 28 (Duty of Care and Remediation of Damage) of the National Environmental Management Act, (Act No. 107 of 1998).*



5.1. (The Client): CapeNature Construction Project Manager

CapeNature must designate a CapeNature employee as Construction Project Manager (CapeNature Construction Project Manager) to take responsibility for implementation of the project as a whole including this EMP and to ensure that the Principal Agent and Contractor fulfil their obligations in terms of this EMP.

The CapeNature Construction Project Manager is responsible for designating, employing or contracting the Principal Agent. The CapeNature Construction Project Manager may designate themselves to act as the Principal Agent, particularly for small contracts.

The CapeNature Construction Project Manager is responsible for ensuring that an Environmental Specialist and ECO are designated or employed, and accepts responsibility for the duration of the project before any on-site work may begin.

For small projects, the CapeNature Construction Project Manager will usually be the Reserve Manager where work will take place, but may also be another CapeNature employee qualified to act as project manager such as the Area Manager or a project officer.

As a signatory to this EMP, the designated CapeNature Construction Project Manager shall take final responsibility for implementation of and compliance with this EMP and making sure that all parties listed here are aware of and carry out their responsibilities in terms of this EMP.



5.2. *Environmental Specialist (CapeNature Environmental Specialist) OR Independent Environmental Specialist.*

As the Western Cape provincial conservation authority, CapeNature will usually be best placed to complete its own EMP and oversee site establishment, rather than use the services of an independent environmental consultant.

The CapeNature Environmental Specialist will be the CapeNature Regional Ecologist responsible for the region in question, or a Land-use Advice Unit official, or the Ecological Planner, or a person designated by the Manager: Scientific Services.

The CapeNature Environmental Specialist must provide site- and activity-specific content for this EMP that identifies risks of environmental damage and the actions and requirements necessary to avoid and/or mitigate environmental damage. The Environmental Specialist must liaise with the Principal Agent, and/or Project Engineer, and/or Contractor/s to identify risks and EMP requirements.

The CapeNature Environmental Specialist must provide a detailed site map for inclusion as part of this EMP (AT SECTION XX) delineating:

- areas where construction, maintenance, or demolition work may be carried out;
- areas where any material or waste may be stored;
- allowed access routes, parking and turning areas for construction or construction related vehicles
- environmentally sensitive and 'no-go' areas

For sites where there is any risk that activities might impact on nearby sensitive areas, the CapeNature Environmental Specialist must supervise the on-site physical demarcation of construction and sensitive/'no-go' areas by means of clear markers, danger tape, or temporary fencing before any construction, demolition or upgrade works may begin. The CapeNature Environmental Specialist may also delegate this task in writing to a suitably qualified ECO but will still assume final responsibility for ensuring that the task is adequately carried out.

For projects where a CapeNature staff member is not available or qualified to perform the above role, the CapeNature Construction Project Manager must appoint a qualified independent environmental consultant to fulfil all these requirements of the Environmental Specialist.

5.3. The Principal Agent

The Principal Agent is designated or appointed by CapeNature and is responsible to CapeNature for ensuring that the construction contract is completed to specification, on time, in budget and that the Contractor fulfils their obligations in terms of the EMP. The Principal Agent must be a signatory to this EMP.

For large projects: The Principal Agent will usually be an appointed architect, engineer or a dedicated project manager appointed by contract to CapeNature. Where projects are managed by Public Works, a designated Public Works official may act as Principal Agent. The Principal Agent can also be a CapeNature employee designated and authorised to act as project Principal Agent.

For smaller projects: The CapeNature Construction Project Manager may also act as the Principal Agent. The Principal Agent may also be another designated CapeNature employee.

The Principal Agent must ensure that any contract between CapeNature and Contractors includes clear and specific reference to the CapeNature Construction EMP and requires that all Contractors and subcontractors adhere to the requirements of this EMP.

The Principal Agent must ensure that the Contractor is provided with a copy of this EMP before any construction contract is signed, that relevant Methods are completed, and that the Contractor is familiar with the relevant documentation.

The Principal Agent will be the senior authority on site.

The Principal Agent and ECO will work closely together and communicate frequently. The Principal Agent will ensure that the ECO undertakes and records inspections of the site as required by the monitoring protocol and checklist, but not less than once every two weeks.

The Principal Agent must communicate any deviation from the requirements of this EMP within 48 hours to both the CapeNature Construction Project Manager and the CapeNature Environmental Specialist in writing or by email.

All communications and instructions between the ECO and the Contractor must occur via the Principal Agent. The Principal Agent is also responsible for work-stoppage or deducting environmental penalties from the Contractor in the event of contravention of requirements of this EMP.

5.4. Environmental Control Officer ("ECO")

The ECO must be appointed prior to commencement of operations.

The ECO will communicate via the Principal Agent unless more urgent action is required to prevent environmental damage.

The ECO must monitor, audit and record compliance with the EMP by all parties on site: The ECO must complete the Environmental Management Programme Audit Checklist (Annexure 1) at each site visit, and keep ad hoc record of any and all incidents or events on site with significant environmental impact in site diary. Significant impacts must be recorded photographically with enough supporting information to locate the image on the site, preferably a GPS coordinate accurate to 10m or better. All records must be dated and accurately catalogued.

The ECO must immediately communicate any contraventions of this EMP, or undesirable environmental impacts to the Principal Agent. If the Principal Agent cannot be contacted and urgent action is required to prevent environmental damage, and/or if in the opinion of the ECO the response of the Principal Agent is not adequate, the ECO must also communicate contraventions of this EMP to the Environmental Specialist and the CapeNature Construction Project Manager.

The ECO has the authority to recommend the stopping of works or any portion of construction related activity to the Principal Agent, if in his/her opinion:

- any activity is in contravention of the requirements of this EMP;
- any activity is in contravention of relevant environmental legislation/permits/authorisations applicable to the site and/or activity/ies, or;
- the activity has caused or will imminently cause significant damage and/or harm to the environment.

If urgent action is required to prevent environmental damage as a result of contravention of the requirements of this EMP, the ECO has the authority to issue a written instruction to the Site Manager, or any person on site to stop works or any portion of construction related activity required to prevent such damage.

The ECO may recommend to the Principal Agent, that any Contractor, Contractor's representative, or any employee/s not adhering to the requirements of this EMP and/or the instructions of the ECO be removed from the site. Alternatively, the ECO may recommend that all work on site be suspended until the matter is remedied.

5.5. The Contractor

The Contractor will assume full responsibility for the on-site actions of all of its sub-Contractors, employees, suppliers and agents.

The Contractor will adhere to the conditions of this EMP and ensure that all sub-Contractors, employees, suppliers and agents are fully aware of this EMP, its requirements and the consequences of any breach of the requirements of this EMP.

The Contractor will ensure that works on site are conducted in an environmentally responsible manner and fully comply with the requirements of this EMP.

The Contractor will report any deviation from the requirements of this EMP to the Principal Agent, and any pollution or environmental contaminant spill events.

The Contractor agrees to work stoppage and/or payment of penalties as required by this EMP and directed by the Principal Agent.

The Contractors agrees bear full costs for any work stoppage resulting from contravention of the requirements of this EMP, and/or the costs of remedying environmental damage resulting from their or their sub-contractors or employee's contravention of the requirements of this EMP.

5.6. Health, Safety and Environmental (HSE) Officer:

A HSE officer for the project must be designated or appointed by the Contractor or Principal Agent, and his/her role is to support the successful implementation of the EMP through:

- Site evaluation on a daily basis.
- Identifying issues relating to day to day construction activities and that can have a detrimental effect on the environment.
- Subcontractor audits to ensure compliance.
- Assist in the direct implementation of the EMP.
- Ensure that the requirements of the EMP are communicated understood by personnel on site via induction sessions.
- Ensure that the contractors on site develop, implement and monitor the required HSE management functions.
- Evaluate the applicability and accuracy of the EMP and the method statements throughout the construction phase.
- Coordinate all statutory requirements including permit authorisation and license requirements.
- Conduct or have conducted a hazard analysis and take the necessary corrective action.
- Where it is not possible to remove any remaining hazard's to inform employees thereof and what precautionary action is to be taken.

- Detail mitigation measures required to be taken, and the procedures for their implementation to the project manager.
- Representing HSE issues at the production meetings.
- Coordinate HSE training of personnel.
- Coordinating spill response personnel.
- The HSE officer shall inspect the integrity of the hazardous waste containers/bins/skips on a weekly basis.

6. STANDARD ENVIRONMENTAL MANAGEMENT PROCEDURES AND ACTIVITIES

6.1. Access - general

All access and vehicular movement on site shall adhere to the following conditions:

- Access will only be allowed during normal reserve operational hours – usually 08h00 until 17h00 Monday to Fridays.
- All Contractors, subcontractors and staff must be identified by clothing with company logos and be in possession of valid SA identity documents.
- Deliveries, removals etc. to be completed during gate open times only.
- All personnel shall be off site by gate closing time unless permission to stay on site provided as part of the construction contract [amend this section if required].
- Access routes must be demarcated by danger tape on steel posts or temporary fencing.
- All vehicles and access to the site must remain within demarcated access routes and working areas on site.
- No new roads or tracks may be created unless specifically permitted by this EMP.

Where heavy duty vehicles and construction plant are required, both the type of vehicles/machinery and the area/s machinery may access shall be specified in this EMP.

The Contractor shall, at his own cost, document the existing condition of all access roads prior to commencement.

Should any damage occur to the access road as a result of the upgrade activities, the road will be rehabilitated to its original state with all costs borne by the contractor.

6.2. Access – demarcated working areas

Construction activities shall be strictly confined to the demarcated working area/s indicated in SECTION XX below to prevent any disturbance to, or contamination of, vegetation, fauna, natural environment or other sensitive features by construction activities. The working areas and ‘no-go’ areas shown here must also be shown on a site map of at least A1 size posted in the construction site office, and be demarcated by temporary fencing on site.

Working areas as shown here are the only areas that may be used by the Contractor to undertake the decommissioning and reconstruction. The Contractor shall ensure that all plant/machinery, vehicles, staff, materials and waste remain within the boundaries of the working area and designated access roads or tracks.

Additional areas shall only be made available by amendment of this EMP by the Environmental Specialist or ECO if required.

Procedure to be followed:

CapeNature must determine and delineate construction, storage and “no-go” areas on site. These areas must be shown on a map to be inserted in SECTION XX of this EMP and duplicated and displayed in the Site Office. Construction and storage areas must also be demarcated on site using steel posts and danger tape durable enough to last for the entire construction project, or temporary fencing. This demarcation must be done by the CapeNature Regional Ecologist or Ecological Coordinator, or by the ECO with work approved by the CapeNature Regional Ecologist or Ecological Coordinator.

The Construction Contractor and ECO will ensure that the construction team, machinery and equipment stay within the working areas and do not encroach on “no-go” areas.

All staff, vehicles and construction materials are restricted to the designated working area.

Contractors may not store any construction material on the sides of the access road, or among the natural vegetation or next to the existing access road.

No waste materials or liquids, including contaminated waste water may be disposed of on site, neither in the designated working area/s, nor any no-go areas. Waste must be held onsite in sealed storage containers and properly disposed of at a designated waste facility. Any exceptions shall be negotiated with the Environmental Control Officer, the Reserve Manger or the Regional Ecologist and amended to this EMP in writing.

7. STORAGE OF CONSTRUCTION MATERIAL

7.1. New Construction Material

New construction materials may only be stored in specifically demarcated areas as per **SECTION XX**.

The Contractor must negotiate appropriate space for this purpose on an area away from natural vegetation and any wetland habitat with the Reserve Manager before completion of **section XX**.

The Contractor must ensure that all staff, contractors and subcontractors are aware of, and keep material within these designated storage areas. The Principle Agent shall ensure that the consultant team is familiar with same.

Contractors will not be allowed to store construction material on the sides of the access roads, or among the natural vegetation.

The Contractor must provide a method statement of the construction activities to CapeNature indicating:

- the type and quantity of material to be stored;
- whether any oil contaminated/containing equipment will be stored; and
- how (including what type of vehicles will be required) material will be delivered to the designated storage area.
- if there is any risk of spill or runoff of any building materials or chemicals and how this is to be mitigated.

8. USE OF CEMENT / CONCRETE

The Contractor is advised that cement and concrete are highly hazardous to the natural environment because of the high pH levels of the material, and the chemicals contained therein.

The following shall apply:

- Prevent cement pollution - ensure that soil and water is not contaminated with cement
- Concrete and cement must only be mixed on existing hard surfaced areas, or edged mortar boards or a suitable container. Concrete may not be mixed or stored directly on the ground under any circumstances;

- The visible remains of the batch and concrete, either solid, or from washings, shall be physically removed immediately and disposed of as hazardous waste.
- Washing of equipment shall be done in a container to prevent any runoff of contaminated washing water. Extreme care must be taken to limit the amount of water contaminated by washing equipment to the minimum required. Water from concrete washing must either be re-used in concrete mixes or must be stored in drums, then removed from the site and disposed of at a licensed municipal dump site.
- No equipment shall be washed in pools or streams within a Nature Reserve.

Failure to comply with the above points will have a severe impact on the wetland habitat and will be considered grounds for stopping works.

9. OIL MANAGEMENT

An important potential environmental impact is oil spills from any oil filled equipment and machinery that may occur during transportation or storage of decommissioned and new construction material/equipment. The following conditions shall apply:

- Vehicles must be checked for oil leaks prior to going on site
- Care should be taken to prevent any potential oil spillage during upgrading activities.
- Sufficient measures should be put in place to ensure that any potential oil spills are mitigated.
- The oil spill kit should be available on site at all times during the construction activities;
- Oil containment facilities should be provided for any oil filled equipment onsite; this must be negotiated with CapeNature
- All oil spills must be reported to the environmental department within 24 hours via a flash report; and
- In the event of oil spill please refer to the Standard for Oil spill Clean-up and Rehabilitation.

Oil spill kits are available from:

Drizit (021) 531 5335

Enretech (021) 683 1858

Should an oil spill occur during upgrade activities, the oil spilled should be contained as soon as possible and the procedure as set out in the Standard for Oil spill clean-up and rehabilitation be followed (refer to Annexure 2 for a copy of the procedure).

10. BRINGING CONSTRUCTION MATERIALS ONTO A NATURE RESERVE

Special care must be taken to prevent bringing in materials contaminated with seed of Invasive Alien Plants (IAPs/weeds). Contractors shall not import construction materials such as sand, gravel or fill contaminated with seed of Invasive Alien Plants, or quarried from areas surrounded by Invasive Alien plant species such as Port Jackson or Rooikrans.

11. WASTE MANAGEMENT

Waste refers to all solid waste, including domestic waste, hazardous waste and construction debris.

The following conditions shall apply:

- To limit the potential for site pollution and the accumulation of waste on site;
- To ensure that waste is disposed of in an appropriate manner at a licensed municipal dump site
- No solid wastes shall be stored on site
- All hazardous waste must be disposed of at a registered hazardous waste disposal site and certificates of safe disposal must be obtained; and
- The contractor shall place and use waste bins on site;
- The waste bins shall be provided with lids and external closing mechanism to prevent contents blowing out;
- The waste bins shall be emptied on a regular basis;
- No waste is to be buried or burnt or otherwise disposed of anywhere but in a registered waste disposal site;
- The Contractor shall provide temporary ablution facilities (i.e. chemical toilets) at a location indicated by the Environmental Specialist or ECO;

- Defecating or urinating anywhere other than in the provided toilet facilities is strictly prohibited (i.e. no use of the veld);
- All waste generated during the decommissioning and reconstruction activities must be removed by the Contractor as soon as possible, and within the period specified in the EMP and disposed of at a registered landfill site.

12. FIRES

No fires are permitted on site for any reason.

Strictly NO SMOKING shall be allowed on general site, due to the high possibility of fires in fynbos areas. If required, a designated smoking area should be provided, and clearly demarcated and signposted, with a facility for safe containment and disposal of cigarette butts.

13. SITE REHABILITATION

Any vehicular damage to the site or Nature Reserve (including roads) caused must be rehabilitated to the satisfaction of CapeNature upon completion of construction activities.

Site rehabilitation must be completed immediately after construction activities or by an alternative date agreed to by CapeNature.

All construction equipment, materials and wastes must be removed from the site upon completion.

14. DOCUMENTATION

Environmental Management Programme Audit Checklist

A complete Environmental Management Programme Audit Checklist is provided in Annexure 1.

The Environmental Management Programme Audit Checklist must be completed by the ECO at each site visit and catalogued as the main record of implementation of and compliance with this EMP.

Hardcopy versions of all *ad hoc* written or photographic records of significant environmental incidents should be filed by date with completed Environmental Management Programme Audit Checklists. Significant impacts must be recorded photographically with enough supporting information to locate the image on the site, preferably a GPS coordinate accurate to 10m or better.

Environmental register

An environmental register must be provided by the Principal Agent and kept on-site at all times as well as being freely accessible to all project team members.

In the event of any environmental incidents, the Environmental Register must be completed by the most senior person on site: the Principal Agent, the Engineer or the Site Manager. The Environmental Register may also be completed by the ECO if the ECO is on site when the incident occurs.

The register will provide a record of all actual environmental incidents that occur as a result of the on-site activity. This may include information related to such aspects as spillages, dust generation and complaints from adjacent neighbours and any other environmental incidents. It must also contain information relating to action taken/mitigation measures employed.

15. CONTRACT OBLIGATIONS

It is understood that all contract documentation related to the construction, operation and decommissioning (if required) of the proposed development will include the conditions of this EMP. It is important to note that the contract obligations must include the recording of any complaints on the project in the environmental register (defined below). It is the responsibility of the ECO to keep an accurate audit trail showing compliance with the EMP during construction phase.

SITE- AND PROJECT-SPECIFIC ENVIRONMENTAL RISKS AND MITIGATION PROCEDURES

In the following section, the Environmental Specialist, in consultation with the Principal Agent and/or Contractors must provide site- and project-specific rules and procedures, in sufficient detail to effectively mitigate any construction related environmental risks.

Items where no environmental risk is identified may be marked “Not applicable”.

Description of works and layout diagram

[describe scope of project and provide layout diagram]

Map of permitted working areas and access routes

[Insert map of site clearly showing:

- permitted access routes
- permitted working areas boundaries
- all access and working area boundaries that must be delimited with temporary fencing (applicable anywhere where there is risk of natural habitat or sensitive features being impacted)
- specific areas to be designated for:
 - storage of construction materials
 - storage of construction waste

16. ACTIONS TO BE COMPLETED BEFORE CONSTRUCTION STARTS

16.1. Bulk Services Identification

[list bulk services required, availability and potential risks]

16.2. Permits

[List all permits required before construction may proceed, and status]

16.3. Access, Working Hours and Working Areas

[list access times outside gate times if required]

[provide map showing access routes, working and “No-Go” areas, and storage areas for both construction and waste materials]

[provide timeline and procedure to danger tape or fence off all natural vegetation and wetland area near construction site as per

diagram of site layout to be provided in site office

16.4. Training

[provide timelines, responsibilities to train all on site teams in EMP rules, regulations and process]

17. CONSTRUCTION PHASE

17.1. Social Considerations

[specify risks & procedures]

17.2. Appropriate Machinery

[specify risks & procedures]

17.3. Traffic Control

[specify risks & procedures]

17.4. Construction Materials

[specify what materials may be used and storage areas]

17.5. Waste Management

[specify waste management processes and storage areas]

17.6. Stormwater

[specify risks & procedures]

17.7. Fire Safety

[specify risks & procedures]

17.8. Safety and First Aid

[specify risks & procedures]

17.9. Air Quality

[specify risks & procedures]

17.10. Water Quality

[specify risks & procedures]

17.11. Noise Pollution

[specify risks & procedures]

17.12. Blasting/Drilling/Demolitions

[specify risks & procedures]

17.13. Light Pollution

[specify risks & procedures]

18. POST CONSTRUCTION

18.1. Final Site Clearance

[specify risks & procedures]

18.2. Rehabilitation

[specify risks & procedures]

19. OPERATIONAL PHASE

Specify management actions and schedules required during facility operational phase. These should be included in the Reserve Management plan.

19.1. Waste Management

[specify risks & procedures]

19.2. Water Use Management

[specify risks & procedures]

19.3. Natural Water Feature Management

[specify risks & procedures]

19.4. Energy Management

[specify risks & procedures]

19.5. Light Pollution

[specify risks & procedures]

19.6. Visual Impact Management

[specify risks & procedures]

19.7. Natural Environment Management

[specify risks & procedures]

19.8. Noise Pollution

[specify risks & procedures]

19.9. Emergency Management

[specify risks & procedures]

19.10. Transport

[specify risks & procedures]

20. DECOMMISSIONING PHASE

Specify procedures required when the site is to be decommissioned

- 20.1. *Waste Management***
- 20.2. *Noise Pollution***
- 20.3. *Site Clearance***
- 20.4. *Blasting/Drilling/Demolitions***
- 20.5. *Air Quality***
- 20.6. *Social Considerations***

**ANNEXURE 1: ENVIRONMENTAL MANAGEMENT PROGRAMME (EMP) –
AUDIT CHECKLIST**

To be completed at each visit of the ECO

[INSERT PROJECT + DATE] Construction Project	Date: _____
Name of Auditor: _____	Construction Representative: _____

	AUDIT QUESTION	YES	NO	ACTION	COMMENTS
Vegetation Management					
1	Have construction activities remained within the designated working areas?				
2	Were all construction materials stored in the appropriate designated area?				
3	Have all decommissioned materials been removed from site?				
4	Has only the demarcated access route/s been used?				

	AUDIT QUESTION	YES	NO	ACTION	COMMENTS
Oil Spills					
5	Are the necessary oil spill clean-up kits on site?				
6	Have any oil or diesel spills occurred on site?				
7	Have oil spills been reported to the Environmental Specialist via a flash report within 24 hours of the spills occurring?				
8	Have oil spills been managed according to the Standard for Oil Spill Clean-Up and Rehabilitation – ESKASABTO				
9	Is there a stock of oil remediation chemicals on site?				

	AUDIT QUESTION	YES	NO	ACTION	COMMENTS
Erosion					
10	Have any complaints been received from CapeNature staff or adjoining property owners regarding occurrence of damage or erosion on their roads or properties as a result of construction activities?				
11	Were any signs of erosion visible during the audit?				
Topsoil Management					
12	Has all the topsoil been backfilled or levelled on site?				
Fire Management					
13	Are the emergency numbers available on site?				
14	Have any incidents of veld fires occurred?				

	AUDIT QUESTION	YES	NO	ACTION	COMMENTS
15	Is the sufficient fire fighting equipment on site? (usually this will be provided by CapeNature on reserves managed by us)				
Water Management					
16	Had any incidents of soil or water pollution occurred?				
17	If yes, was report issued within 24hrs to the ECO and reserve manager and CapeNature Ecological Planner?				
18	Was the incident investigated and recommendations implemented?				
19	Is there sufficient potable water available?				
20	Are there sufficient portable toilets available?				

	AUDIT QUESTION	YES	NO	ACTION	COMMENTS
Social Issues					
21	Were any public complaints registered and actioned?				
Waste Management					
22	Are there sufficient waste bins on site?				
23	Does the waste bin have lids to prevent waste from blowing off?				
24	Was litter noted during site inspection?				
Use of cement and/or concrete					
25 a	Was any excess cement of concrete noted during the site inspection?				

	AUDIT QUESTION	YES	NO	ACTION	COMMENTS
25 b	Was there any evidence of site contamination by washing of cement or concrete equipment?				
Environmental Records					
26	Is a copy of Environmental Management Programme (EMP) available on site?				

ANNEXURE 2 - KEY SITE RULES DURING CONSTRUCTION

A copy of these rules must be posted at the site office and explained to all on-site staff by the ECO in addition to the more general conditions and procedures detailed above.

To ensure compliance with environmental best practise, as well as environmental legislation requirements, the following rules apply on site:

Demarcated work /construction areas

All construction staff and vehicles must stay within demarcated working areas at all times to prevent damage to natural habitats. These areas are shown on the map (pg XX) in the site office and by danger tape or fencing on the site.

Use of Cement or Concrete

Concrete has a large and permanent impact on soils in natural habitat and **concrete contamination will cause very high negative environmental impact**, therefore:

- Concrete and cement must only be mixed on existing concrete slabs demarcated for mixing or, or on edged mortar boards or in a suitable container;
- No spilling of concrete off of mixing areas may happen
- Concrete may not be mixed or stored directly on the ground under any circumstances;
- Any remains of the batch and concrete, either solid, or from washings, must be physically removed immediately and disposed of as hazardous waste.
- Washing of equipment must be done in a container away from the construction area to prevent any runoff of contaminated washing water. Extreme care must be taken to limit the amount of water contaminated by washing equipment to the minimum required. Water from concrete washing must either be re-used in concrete mixes or must be stored in drums, then removed from the site and disposed of at a licensed municipal dump site.

Water Quality and Wetland Habitat Protection

Under no circumstances must surface or ground water be polluted (oil, petrol, cleaning materials, incorrect herbicides usage, etc).

Fire safety, Air Quality

No fires may be made at all, including burning of waste material or any vegetation, may take place

Waste Management

No littering or illegal dumping of any waste material is to take place, especially plastics on site;

Provision must be made for the collection of all waste materials on site in suitable containers

If existing flush toilets are not available on site, temporary ablution facilities (i.e. Chemical toilets) must be made available and used. These should be placed at least 50m from any wetland or drainage line. Abluting anywhere other than in the toilet facilities available shall not be permitted (i.e. no abluting in the veld);

All recyclable material should (where economically viable) be re-used, returned or sold as scrap;

Servicing and cleaning of vehicles on site is strictly prohibited; and

During construction operations, no surplus cement or concrete may not be dumped on site, but shall be disposed of at a registered waste disposal site.

Prevention of road, fauna and habitat damage by vehicles

Drive at moderate speeds (slower than 15 km/hr) on access roads

Nature Reserve Protection

No animals, including mammals, birds, snakes, and invertebrates may be harmed or killed.

No plants outside of demarcated work areas may be damaged. No firewood may be collected.

No fences or gates of property owners must be damaged. Gates must be kept closed at any times specified by the reserve manger;

Soil erosion must be prevented at all times along access road. Vehicle movement should be kept to a minimum during rain to avoid damage to access roads;

No fires may be made anywhere in a Nature Reserve or on adjoining properties.

Other

Members of the public visiting the Nature Reserve and surrounding property owners or occupiers must be treated with respect and courtesy at all times;

ANNEXURE 3: NATIONAL ENVIRONMENTAL MANAGEMENT ACT PRINCIPLES

The NEMA Principles states that sustainable development requires the consideration of all relevant factors including the following:

- *Disturbance of ecosystems and loss of biological diversity must be prevented, or, where they cannot be altogether avoided, must be minimised and remedied;*
- *Pollution and degradation of the environment must be avoided, or, where they cannot be altogether avoided, must be minimised and remedied;*
- *Disturbance of landscapes and sites that constitute the nation's cultural heritage must be avoided, or where it cannot be altogether avoided, must be minimised and remedied;*
- *Waste must be avoided, or where it cannot be altogether avoided, minimised and re-used or recycled where possible and otherwise dispose of in a responsible manner;*
- *Use and exploitation of non-renewable natural resources must be responsible and equitable, and take into account the consequences of the depletion of the resource;*
- *Development, use and exploitation of renewable resources and the ecosystems of which they are part must not exceed the level beyond which their integrity is jeopardised;*
- *A risk-averse and cautious approach must be applied, that takes into account the limits of current knowledge about the consequences of decisions and actions; and*
- *Negative impacts on the environment and on people's environmental rights must be anticipated and prevented, and where they cannot be altogether prevented, must be minimised and remedied.*