

<b>TENDER DOCUMENT GOODS AND SERVICES</b>		 CITY OF CAPE TOWN ISIXEKO SASEKAPA STAD KAAPSTAD
<b>SUPPLY CHAIN MANAGEMENT</b>		
SCM - 542	Approved by Branch Manager: February 2024	Version: 10

**TENDER NO: 2G/2026/27**

**TENDER DESCRIPTION:[TERM TENDER OF THE SUPPLY AND DELIVERY, INSTALLATION OF NEW OUTDOOR EXERCISE EQUIPMENT AND THE REPAIRS TO EXISTING OUTDOOR EXERCISE EQUIPMENT]**

**CONTRACT PERIOD: [36] MONTHS FROM THE COMMENCEMENT DATE OF THE CONTRACT**

**CLOSING DATE** **7 August 2026**

**CLOSING TIME** **10:00 am**

**TENDER BOX NUMBER** **243**

**TENDER FEE** **R200.00**

Non – refundable tender fee payable to the City of Cape Town (CCT) for a hard copy of the tender document. This fee is not applicable to website downloads of the tender document.

<b>TENDERER</b>	
<b>NAME of Company/Close Corporation or Partnership / Joint Venture/ Consortium or Sole Proprietor /Individual (hereinafter the "Tenderer")</b>	
<b>TRADING AS (if different from above)</b>	
<b>Registration number of Tenderer</b>	
<b>Physical address and chosen domicilium citandi et executandi of Tenderer</b>	

<b>NATURE OF TENDER OFFER (please indicate below)</b>	
<b>Main Offer (see clause 2.2.11.1)</b>	
<b>Alternative Offer (see clause 2.2.11.1)</b>	

<b>TENDER SERIAL NO.:</b>
<b>SIGNATURES OF CCT OFFICIALS AT TENDER OPENING</b>
<b>1</b>
<b>2</b>
<b>3</b>

## TABLE OF CONTENTS

<b>THE TENDER</b> .....	<b>3</b>
T.1 GENERAL TENDER INFORMATION .....	3
T.2 CONDITIONS OF TENDER .....	4
2.1 General.....	4
2.2 Tenderer’s obligations .....	8
2.3 The CCT’s undertakings.....	15
<b>THE CONTRACT</b> .....	<b>22</b>
C.1 DETAILS OF TENDERER/SUPPLIER .....	23
C.2 FORM OF OFFER AND ACCEPTANCE .....	24
C.2.1 OFFER (TO BE COMPLETED BY THE TENDERER AS PART OF TENDER SUBMISSION).....	24
C.2.2 ACCEPTANCE (TO BE COMPLETED BY THE CCT) .....	25
C.2.3 SCHEDULE OF DEVIATIONS (TO BE COMPLETED BY THE CCT UPON ACCEPTANCE) .....	26
C.2.4 CONFIRMATION OF RECEIPT (TO BE COMPLETED BY SUPPLIER UPON ACCEPTANCE).....	27
C.3 OCCUPATIONAL HEALTH AND SAFETY AGREEMENT .....	28
C.4 PRICE SCHEDULE .....	29
C.5 SPECIFICATION(S).....	50
C.6 SPECIAL CONDITIONS OF CONTRACT .....	73
C.7 GENERAL CONDITIONS OF CONTRACT .....	84
C.8 ANNEXURES .....	94
ANNEXURE A – PRO FORMA INSURANCE BROKER’S WARRANTY .....	94
ANNEXURE B – MONTHLY PROJECT LABOUR REPORT .....	95
ANNEXURE C - PRO FORMA PERFORMANCE SECURITY/ GUARANTEE .....	97
ANNEXURE D - PRO FORMA ADVANCE PAYMENT GUARANTEE .....	100
ANNEXURE F - TENDER RETURNABLE DOCUMENTS.....	103
<i>Schedule F.1: Contract Price Adjustment and/or Rate of Exchange Variation.....</i>	<i>103</i>
<i>Schedule F.2: Certificate of Authority for Partnerships/ Joint Ventures/ Consortiums .....</i>	<i>113</i>
<i>Schedule F.3: Declaration for Procurement above R10 million.....</i>	<i>114</i>
<i>Schedule F.4: Preference Points Claim Form In Terms Of the Preferential Procurement Regulations 2022 .....</i>	<i>115</i>
<i>Schedule F.5: Declaration of Interest – State Employees (MBD 4 amended).....</i>	<i>125</i>
<i>Schedule F.6: Conflict of Interest Declaration .....</i>	<i>127</i>
<i>Schedule F.7: Declaration of Tenderer’s Past Supply Chain Management Practices (MBD 8).....</i>	<i>128</i>
<i>Schedule F.8: Authorisation for the Deduction of Outstanding Amounts Owed to the CCT .....</i>	<i>130</i>
<i>Schedule F.9: Certificate of Independent Tender Determination.....</i>	<i>131</i>
<i>Schedule F.10: Proposed Deviations And Qualifications By Tenderer.....</i>	<i>132</i>
<i>Schedule F.11: List of Other Documents Attached By Tenderer.....</i>	<i>133</i>
<i>Schedule F.12: Record of Addenda to Tender Documents .....</i>	<i>134</i>
<i>Schedule F.13: Information to Be Provided With the Tender.....</i>	<i>135</i>
<i>Schedule F13.1 : Quality Control Procedure.....</i>	<i>136</i>
<i>Schedule F13.2 : Gym Equipment Drawings and Sample Examples.....</i>	<i>137</i>
<i>Schedule F13.3 : Schedules .....</i>	<i>145</i>
F13.3 SCHEDULE 1: SUPPLY OF OUTDOOR GYM EQUIPMENT.....	146
F13.3 SCHEDULE 2 INSTALLATION OF OUTDOOR GYM EQUIPMENT .....	148
F13.3 SCHEDULE 3 REPAIRING OF OUTDOOR GYM EQUIPMENT .....	150
<i>Schedule F13.4 : Evaluation Criteria .....</i>	<i>154</i>
<i>Schedule F13.5 : Regional Diagram .....</i>	<i>155</i>
<i>Schedule F13.6 : Region Tendering for.....</i>	<i>156</i>
<i>Schedule F.14 : Appeal Application Form.....</i>	<i>157</i>

## THE TENDER

<b>T.1 GENERAL TENDER INFORMATION</b>
---------------------------------------

<b>TENDER ADVERTISED</b>	:	<b>03 July 2026</b>
<b>SITE VISIT/CLARIFICATION MEETING</b>	:	Time: <b>10h00am</b> on Date <b>13 July 2026</b> (Not compulsory, but strongly recommended)
<b>VENUE FOR SITE VISIT/CLARIFICATION MEETING</b>	:	<b>Parow Committee Room, 12 Tallent Road, Parow or via Teams:</b> <a href="https://teams.microsoft.com/meet/351762665797208?p=yQX7bYbk1MVfLqsv9x">https://teams.microsoft.com/meet/351762665797208?p=yQX7bYbk1MVfLqsv9x</a> <b>Meeting ID: 360 048 352 214 095</b> <b>Passcode: 9c6Pa6sC</b>
<b>TENDER BOX &amp; ADDRESS</b>	:	<b>Tender Box as per front cover</b> at the <b>Tender &amp; Quotation Boxes Office</b> , 2 <sup>nd</sup> Floor (Concourse Level), Civic Centre, 12 Hertzog Boulevard, Cape Town.
	:	The Tender Document (which includes the Form of Offer and Acceptance) completed and signed in all respects, plus any additional supporting documents required, must be submitted in a sealed envelope with the name and address of the tenderer, the endorsement " <b>TENDER NO. [2G/2026/27: - TENDER DESCRIPTION: [TERM TENDER OF THE SUPPLY AND DELIVERY, INSTALLATION OF NEW OUTDOOR EXERCISE EQUIPMENT AND THE REPAIRS TO EXISTING OUTDOOR EXERCISE EQUIPMENT]</b> ", the tender box number. and the closing date indicated on the envelope. The sealed envelope must be inserted into the appropriate official tender box before closing time. If the tender offer is too large to fit into the abovementioned box or the box is full, please enquire at the public counter (Tender Distribution Office) for alternative instructions. It remains the tenderer's responsibility to ensure that the tender is placed in either the original box or as alternatively instructed.
<b>CCT TENDER REPRESENTATIVE</b>	:	Email: [ <b>SCM.Tenders25@capetown.gov.za</b> ]

**TENDERERS MUST NOTE THAT WHEREVER THIS DOCUMENT REFERS TO ANY PARTICULAR TRADE MARK, NAME, PATENT, DESIGN, TYPE, SPECIFIC ORIGIN OR PRODUCER, SUCH REFERENCE SHALL BE DEEMED TO BE ACCOMPANIED BY THE WORDS "OR EQUIVALENT"**

## T.2 CONDITIONS OF TENDER

### 2.1 General

#### 2.1.1 Actions

**2.1.1.1** The City of Cape Town (hereafter referred to as the "CCT") and each tenderer submitting a tender offer (hereinafter referred to as the "tenderer" or the "supplier") shall comply with item T.2 of this Tender Document Goods and Services (hereinafter referred to as these "Conditions of Tender"). The tenderer and the CCT shall collectively hereinafter be referred to as the "Parties" and individually a "Party"). In their dealings with each other, the Parties shall discharge their duties and obligations as set out in these Conditions of Tender, timeously and with integrity, and behave equitably, honestly and transparently, and shall comply with all legal obligations imposed on the Parties herein and in accordance with all applicable laws.

**The Parties agree that this tender Tender Document Goods and Services (hereinafter referred to as the "Tender" / "Tender Document"), its evaluation and acceptance and any resulting contract shall also be subject to the CCT's Supply Chain Management Policy ('SCM Policy') that was applicable on the date the bid was advertised and as amended from time to time. If the CCT adopts a new SCM Policy which contemplates that any clause therein would apply to the Contract emanating from this tender (hereinafter referred to as the "Contract"), such clause shall also be applicable to that Contract. Please refer to this document contained on the CCT's website.**

**Abuse of the supply chain management system is not permitted and may result, inter alia, (1) in the tender being rejected; (2) cancellation of the contract; (3) restriction of the supplier, and/or (4) the exercise by the CCT of any other remedies available to it as provided for in the SCM Policy and/or the the Contract and/or this tender and/or any applicable laws .**

**2.1.1.2** The CCT, the tenderer and their agents and employees involved in the tender process shall avoid conflicts of interest and where a conflict of interest is perceived or known, declare any such conflict of interest, indicating the nature of such conflict. Tenderers shall declare any potential conflict of interest in their tender submissions. Employees, agents and advisors of the CCT shall declare any conflict of interest to the CCT at the start of any deliberations relating to the procurement process or as soon as they become aware of such conflict, and abstain from any decisions where such conflict exists or recuse themselves from the procurement process, as appropriate.

**2.1.1.3** The CCT shall not seek, and a tenderer shall not submit a tender, without having a firm intention and capacity to proceed with the contract.

#### 2.1.2 Interpretation

**2.1.2.1** The additional requirements contained in Annexure F to the contract (hereinafter referred to as the "returnable documents" / "Returnable Schedules") are part of these Conditions of Tender and are specifically hereby incorporated into these Conditions of Tender.

**2.1.2.2** These Conditions of Tender and returnable Documents which are required for CCT's tender evaluation purposes herein, shall form part of the Contract arising from the CCT's corresponding invitation to tender.

#### 2.1.3 Communication during tender process

Verbal or any other form of communication, from the CCT, its employees, agents or advisors during site visits/clarification meetings or at any other time prior to the award of the Contract, will not be regarded as binding on the CCT, unless communicated by the CCT in writing to suppliers / tenderers by its Director: Supply Chain Management or his nominee. Similarly, any communication of the tenderer / supplier that is not reduced to writing by the tenderer / supplier, its employees, agents or advisors, shall not be regarded as binding on the CCT, unless communicated to the CCT in writing by the suppliers / tenderers, or their duly authorised representatives.

**2.1.4 The CCT’s right to accept or reject any tender offer**

**2.1.4.1** The CCT may accept or reject any tender offer and may cancel the corresponding tender process or reject all tender offers at any time before the formation of a contract. The CCT may, prior to the award of the tender, cancel a tender if:

- (a) due to changed circumstances, there is no longer a need for the services, works or goods requested; or
- (b) funds are no longer available to cover the total envisaged expenditure; or
- (c) no acceptable tenders are received;
- (d) there is a material irregularity in the tender process; or
- (e) the Parties are unable to negotiate market related pricing.

The CCT shall not accept or incur any liability to a tenderer for such cancellation or rejection, but will give written reasons for such action upon receiving a written request to do so.

**2.1.5 Procurement procedures**

**2.1.5.1 General**

[Unless otherwise stated in the Conditions of Tender, a contract will be concluded with the tenderer who scores the highest number of tender adjudication points.

The CCT intends to appoint one tenderer (the highest ranked responsive tenderer (“the winner”) in a Region and in addition one (“alternative tenderer” – the next highest ranked responsive tenderer) for the allocation of work. If insufficient responsive bids are received, the CCT reserves the right to appoint fewer tenderers, or not to appoint any tenderers at all.

Suppliers, once appointed and subject to operational requirements, will be invited to deliver the goods or services on a “winner-takes-all” basis, whereby the order will always be offered and, if accepted, allocated to the highest ranked tenderer (“the winner”), and only if he refuses will the work be offered to the next highest ranked tenderer from the alternative tenderers).

**Regions and Areas Defined**

<b>Region 1</b>	<b>Region 2</b>
Blaauwberg, Northern, Table Bay, Tygerberg	Southern, Cape Flats, Mitchells Plain/Khayelitsha, Helderberg

- In cases of ordinary work and emergencies, orders will be placed in the first instance with the highest ranked tenderer (Winner), and if they are not willing to accept the works or confirm acceptance of works within 5 working days, then the order will be placed with the second highest ranked tenderer (Alternative Tenderer)
- The City reserves a right to award one or more regions per contractor.

The contract period shall be for a period of [ 36 ] months from the commencement date of the contract.]

**2.1.5.2 Proposal procedure using the two stage-system**

A two-stage system [will not] be followed.

**2.1.5.2.1** Tenderers shall submit in the first stage only technical proposals. The CCT shall invite all responsive tenderers to submit tender offers in the second stage, following the issuing of applicable procurement documents.

**2.1.5.2.2** The CCT shall evaluate tenders received during the second stage in terms of the method of evaluation stated in the Conditions of Tender, and award the contract in terms of these Conditions of Tender.

**2.1.5.3 Nomination of Standby Bidder**

“Standby Bidder” means a bidder, identified by the CCT at the time of awarding a bid that will be considered for award should the contract be terminated for any reason whatsoever. In the event that a contract is terminated during the execution thereof, the CCT may consider the award of the contract, or non-award, to the Standby Bidder in terms of the procedures included its SCM Policy, as amended from time to time.

**2.1.6 Objections, complaints, queries and disputes/ Appeals in terms of Section 62 of the Systems Act/ Access to court**

**2.1.6.1 Disputes, objections, complaints and queries**

In terms of Regulations 49 and 50 of the Local Government: Municipal Finance Management Act, 56 of 2003 Municipal Supply Chain Management Regulations (Board Notice 868 of 2005):

- a) Persons aggrieved by decisions or actions taken by the CCT in the implementation of its supply chain management system, may lodge within 14 days of the decision or action, a written objection or complaint or query or dispute against the decision or action.

**2.1.6.2 Appeals**

- a) In terms of Section 62 of the Local Government: Municipal Systems Act, 32 of 2000 a person whose rights are affected by a decision taken by the CCT, may appeal against that decision by giving written notice of the appeal and reasons to the City Manager within 21 days of the date of the notification of the decision.
- b) An appeal must contain the following:
- i. Must be in writing
  - ii. It must set out the reasons for the appeal
  - iii. It must state in which way the Appellant’s rights were affected by the decision;
  - iv. It must state the remedy sought; and
  - v. It must be accompanied with a copy of the notification advising the person of the decision
- c) The relevant CCT appeal authority must consider the appeal and **may confirm, vary or revoke** the decision that has been appealed, but no such revocation of a decision may detract from any rights that may have accrued as a result of the decision.

**2.1.6.3 Right to approach the courts and rights in terms of Promotion of Administrative Justice Act, 3 of 2000 and Promotion of Access to Information Act, 2 of 2000**

The sub- clauses above do not influence any affected person’s rights to approach the High Court at any time or its rights in terms of the Promotion of Administrative Justice Act (PAJA) and Promotion of Access to Information Act (PAIA).

- 2.1.6.4** All requests referring to sub clauses 2.1.6.1 and 2.1.6.2 must be submitted in writing to:  
**The City Manager** - C/o the Manager: Legal Compliance Unit, Legal Services Department, Office of the City Manager

**Via hand delivery at:** 20<sup>th</sup> Floor, Tower Block, 12 Hertzog Boulevard, Cape Town 8001

**Via post at:** Private Bag X918, Cape Town, 8000

**Via email at:** [MSA.Appeals@capetown.gov.za](mailto:MSA.Appeals@capetown.gov.za)

- 2.1.6.5** All requests referring to clause 2.1.6.3 must be submitted in writing to:  
**The City Manager** - C/o the Manager: Access to Information Unit, Legal Service Department, Office of the City Manager

**Via hand delivery at:** 20<sup>th</sup> Floor, Tower Block, 12 Hertzog Boulevard, Cape Town 8001

**Via post at:** Private Bag X918, Cape Town, 8000

**Via email at:** [Access2info.Act@capetown.gov.za](mailto:Access2info.Act@capetown.gov.za)

**2.1.6.6 The minimum standards regarding accessing and 'processing' of any personal information belonging to another in terms of Protection of Personal Information Act, 2013 (POPIA).**

For purposes of this clause 2.1.6.6, the contract and these Conditions of Tender, the terms “data subject”, “Personal Information” and “Processing” shall have the meaning as set out in section 1 of POPIA, and “Process” shall have the corresponding meaning.

The CCT, its employees, representatives and sub-contractors may, from time to time, Process the tenderer's and/or its employees', representatives' and/or sub-contractors' Personal Information, for

purposes of, and/or relating to, the tender, the contract and these Conditions of Tender, for research purposes, and/or as otherwise may be envisaged in the CCT's Privacy Notice and/or in relation to the CCT's Supply Chain Management Policy or as may be otherwise permitted by law. This includes the Processing of the latter Personal Information by the CCT's due diligence assurance provider, professional advisors and the Appeal Authority as applicable. The CCT's justification for the processing of such aforesaid Personal Information is based on section 11(1)(b) of POPIA, i.e., in terms of which the CCT's Processing of the said Personal Information is necessary to carry out actions for the conclusion and/or performance of the contract, to which the applicable data subject (envisaged in this clause 2.1.6.6 above) is a party.

All requests relating to data protection must be submitted in writing to:  
The City Manager - C/o the Information Officer, Office of the City Manager  
Via hand delivery at: 20th Floor, Tower Block, 12 Hertzog Boulevard, Cape Town 8001  
Via post at: Private Bag X9181, Cape Town, 8000  
Via email at: Popia@capetown.gov.za.

#### **2.1.6.7 Compliance to the CCTs Appeals Policy.**

In terms of the CCT's Appeals Policy, a fixed upfront administration fee will be charged. In addition, a surcharge may be imposed for vexatious and frivolous or otherwise manifestly inappropriate tender related appeals.

The current approved administration fee is R300.00 and may be paid at any of the Municipal Offices or at the Civic Centre in Cape Town using the GL Data Capture Receipt attached as Annexure F.14: Appeal Application Form. Alternatively, via EFT into the CCT's NEDBANK Account: CITY OF CAPE TOWN and using Reference number: 198158966. You are required to send proof of payment when lodging your appeal.

The current surcharge for vexatious and frivolous or otherwise manifestly inappropriate tender related appeals will be calculated as  $\frac{1}{2}$  (Administrative cost of the tender appeal) + 0.25 % (Appellant's tender price).

Should the payment of the administration fee of R300.00 or the surcharge not be received, such fee or surcharge will be added as a Sundry Tariff to the bidder's municipal account.

In the event where the bidder does not have a Municipal account with the CCT, the fee or surcharge may be recovered in terms of the CCT's Credit Control and Debt Collection By-law, 2006 (as amended) and its Credit Control and Debt Collection Policy.

#### **2.1.7 CCT Supplier Database Registration**

Tenderers are required to be registered on the CCT Supplier Database as a service provider. Tenderers must register as such upon being requested to do so in writing and within the period contained in such a request, failing which no orders can be raised or payments processed from the resulting contract. In the case of Joint Venture partnerships this requirement will apply individually to each party of the Joint Venture.

Tenderers who wish to register on the CCT's Supplier Database may collect registration forms from the Supplier Management Unit located within the Supplier Management / Registration Office, 2<sup>nd</sup> Floor (Concourse Level), Civic Centre, 12 Hertzog Boulevard, Cape Town (Tel 021 400 9242/3/4/5). Registration forms and related information are also available on the CCT's website [www.capetown.gov.za](http://www.capetown.gov.za) (follow the Supply Chain Management link to Supplier registration).

It is each tenderer's responsibility to keep all the information on the CCT Supplier Database updated.

#### **2.1.8 National Treasury Web Based Central Supplier Database (CSD) Registration**

Tenderers are required to be registered on the National Treasury Web Based Central Supplier Database (CSD) as a service provider. Tenderers must register as such upon being requested to do so in writing and within the period contained in such a request, failing which no orders can be raised or payments processed from the resulting contract. In the case of Joint Venture partnerships this requirement will apply individually to each party of the Joint Venture.

Tenderers who wish to register on the National Treasury Web Based Central Supplier Database (CSD) may

do so via the web address <https://secure.csd.gov.za>.

It is each tenderer's responsibility to keep all the information on the National Treasury Web Based Central Supplier Database (CSD) updated.

## 2.2 Tenderer's obligations

### 2.2.1 Eligibility Criteria

**2.2.1.1 Tenderers are obligated to submit a tender offer that complies in all aspects to the conditions as detailed in this tender document and the Conditions of Tender. An 'acceptable tender must "COMPLY IN ALL" aspects with the tender, Conditions of Tender, all Specifications (i.e., item C.5 below, hereinafter the "Specifications"), pricing instructions herein and the Contract including its conditions.**

#### 2.2.1.1.1 Submit a tender offer

Only those tender submissions from which it can be established, *inter alia* that a clear, irrevocable and unambiguous offer has been made to CCT, by whom the offer has been made and what the offer constitutes, will be declared responsive.

#### 2.2.1.1.2 Compliance with requirements of CCT SCM Policy and procedures

Only those tenders that are compliant with the requirements below will be declared responsive:

- a) A completed **Details of Tenderer** to be provided (applicable schedule below to be completed);
- b) A completed **Certificate of Authority for Partnerships/ Joint Ventures/ Consortiums** to be provided authorising the tender to be made and the signatory to sign the tender on the partnership /joint venture/consortium's (applicable schedule below to be completed);
- c) A copy of the partnership / joint venture / consortium agreement to be provided, where applicable.
- d) A completed **Declaration of Interest – State Employees** to be provided and which does not indicate any non-compliance with the legal requirements relating to state employees (applicable schedule below to be completed);
- e) A completed **Declaration – Conflict of Interest and Declaration of Bidders' past Supply Chain Management Practices** to be provided and which does not indicate any conflict or past practises that renders the tender non-responsive based on the conditions contained thereon (applicable schedules below to be completed);
- f) A completed **Certificate of Independent Bid Determination** to be provided and which does not indicate any non-compliance with the requirements of the schedule (applicable schedule below to be completed);
- g) The tenderer (including any of its representatives, directors or members), has not been restricted in terms of abuse of the Supply Chain Management Policy,
- h) The tenderer's tax matters with SARS are in order, or the tenderer is a foreign supplier that is not required to be registered for tax compliance with SARS;
- i) The tenderer is not an advisor or consultant contracted with the CCT whose prior or current obligations creates any conflict of interest or unfair advantage;
- j) The tenderer is not a person, advisor, corporate entity or a director of such corporate entity, who is directly or indirectly involved or associated with the bid specification committee;
- k) A completed **Authorisation for the Deduction of Outstanding Amounts Owed to the CCT** to be provided and which does not indicate any details that renders the tender non-responsive based on the conditions contained thereon (applicable schedules below to be completed);
- l) The tenderer (including any of its representatives, directors or members), has not been found guilty of contravening the Competition Act 89 of 1998, as amended from time to time;
- m) The tenderer (including any of its representatives, directors or members), has not been found guilty on any other basis listed in the Supply Chain Management Policy.

**2.2.1.1.4 Minimum score for functionality**

Only those tenders submitted by tenderers who achieve the minimum score for functionality as stated below will be declared responsive.

The description of the functionality criteria and the maximum possible score for each is shown in the table below. The score achieved for functionality will be the sum of the scores achieved, in the evaluation process, for the individual criteria.

Description of functionality criteria	Maximum possible score
1. Demonstrated experience of the tendering entity with respect to a comparable project <b>Supplying of Outdoor Gym Equipment (See Schedule F13.1):</b> 0 projects .....0 points 1 - 2 projects ..... 10 points 3 - 4 projects ..... 25 points 5 or more projects .....35 points	35
2. Demonstrated experience of the tendering entity with respect to a comparable project in <b>Installation of Outdoor Gym Equipment (See Schedule F13.2):</b> 0 projects .....0 points 1 - 2 projects ..... 10 points 3 - 4 projects ..... 25 points 5 or more projects .....35 points	35
3. Demonstrated experience of the tendering entity with respect to a comparable project in <b>Repairing Outdoor Gym Equipment (See Schedule F13.3):</b> 0 projects .....0 points 1 - 2 projects ..... 10 points 3 - 4 projects ..... 20 points 5 or more projects .....30 points	30
<b>Maximum possible score for Functionality</b> <b>Minimum possible score for Functionality</b>	<b>100</b> <b>60</b>

The minimum qualifying score for functionality is [ 60 ] out of a maximum of [100].

Where the entity tendering is a Joint Venture, the tenderer’s tender response must be accompanied by a statement describing exactly what aspects of the work will be undertaken by each party to the joint venture.

Tenderers shall ensure that all relevant information has been submitted with the tender offer in the prescribed format to ensure optimal scoring of functionality points for each Evaluation Criteria. Failure to provide all information **IN THIS TENDER SUBMISSION** could result in the tenderer not being able to achieve the specified minimum scoring.

A more detailed explanation of the functionality criteria is given below:

[  
 Tenderers are to submit the relevant information required to obtain points for each of the criterion listed in the table above. Tenderers to complete the Schedules 1 – 3 in F13.3 in the spaces provided. Where the word Project is stated, this is to apply for Completed Projects and not works in progress.

Do note that the Job Completion Certificates and/or Invoices would be deemed viable with the submission of your project/s.

**2.2.1.1.7 Provision of samples**

Not Applicable.

**2.2.2 Cost of tendering**

The CCT will not be liable for any costs incurred in the preparation and submission of a tender offer, including the costs of any testing necessary to demonstrate that aspects of the offer complies with requirements.

**2.2.3 Check documents**

The documents issued by the CCT for the purpose of a tender offer are listed in the index of this tender document.

Before submission of any tender, the tenderer should check the number of pages, and if any are found to be missing or duplicated, or the figures or writing is indistinct, or if the Price Schedule contains any obvious errors, the tenderer must apply to the CCT at once to have the same rectified.

**2.2.4 Confidentiality and copyright of documents**

The tenderer shall treat as strictly confidential all matters arising in connection with the tender. Use and copy the documents issued by the CCT only for the purpose of preparing and submitting a tender offer in response to the invitation.

**2.2.5 Reference documents**

The tenderer shall obtain, as necessary for submitting a tender offer, copies of the latest versions of standards, specifications, Conditions of Contract and other publications, which are not attached but which are incorporated into the tender document(s) by reference.

**2.2.6 Acknowledge and comply with notices**

The tenderer shall acknowledge receipt of notices to the tender documents, which the CCT may issue, and shall fully comply with all instructions issued in the said notices, and if necessary, apply for an extension of the closing time stated on the front page of the tender document, in order to take the notices into account. Notwithstanding any requests for confirmation of receipt of the said notices issued, the tenderer shall be deemed to have received such notices if the CCT can show proof of transmission thereof via electronic mail, facsimile, or registered post or other lawful means.

**2.2.7 Clarification meeting**

The tenderer shall attend, where required, a clarification meeting at which tenderers may familiarise themselves with aspects of the proposed work, services or supply and pose questions. Details of the meeting(s) are stated in the General Tender Information (i.e., in item T.1 above).

Tenderers should be represented at the site visit/clarification meeting by a duly authorised person who is suitably qualified and experienced to comprehend the implications of the work involved.

**2.2.8 Seek clarification**

The tenderer shall request clarification of the tender documents, if necessary, by notifying the CCT at least one week before the closing time stated in the General Tender Information (i.e., in item T.1 above), where possible.

**2.2.9 Pricing the tender offer**

**2.2.9.1** The tenderer shall comply with all pricing instructions as stated on the Price Schedule.

**2.2.10 Alterations to documents**

The tenderer shall not make any alterations or additions to the tender documents, except to comply with instructions issued by the CCT in writing, or necessary to correct errors made by the tenderer. All signatories to the tender offer shall initial all such alterations.

**2.2.11 Alternative tender offers**

**2.2.11.1** Unless otherwise stated in the Conditions of Tender, the tenderers may submit alternative tender offers only if a main tender offer, strictly in accordance with all the requirements of the tender documents, is also submitted.

If a tenderer wishes to submit an alternative tender offer, he/she/it shall do so as a separate offer on a complete set of tender documents. The alternative tender offer shall be submitted in a separate sealed envelope clearly marked "Alternative Tender" in order to distinguish it from the main tender offer.

Only the alternative of the highest ranked acceptable main tender offer (that is, submitted by the same tenderer) will be considered, and if appropriate, recommended for award.

Alternative tender offers of any but the highest ranked main tender offer will not be considered.

An alternative tender offer to the highest ranked acceptable main tender offer that is priced higher than the main tender offer may be recommended for award, provided that the ranking of the alternative tender offer is higher than the ranking of the next ranked acceptable main tender offer.

The CCT will not be bound to consider alternative tenders and shall have sole discretion in this regard.

In the event that the alternative is accepted, the tenderer warrants that the alternative offer complies in all respects with the CCT's standards and requirements as set out in the tender document.

**2.2.11.2** Acceptance of an alternative tender offer by the CCT may be based only on the criteria stated in the Conditions of Tender or applicable criteria otherwise acceptable to the CCT.

**2.2.12 Submitting a tender offer**

**2.2.12.1** The tenderer is required to submit one tender offer only on the original tender documents as issued by the CCT, either as a single tendering entity or as a member in a joint venture to provide the whole of the works, services or supply identified in the Conditions of Contract and described in the Specifications. Only those tenders submitted on the tender documents as issued by the CCT together with all Tender Returnable Documents duly completed and signed will be declared responsive.

**2.2.12.2** The tenderer shall return the entire tender document to the CCT after completing it in its entirety, either electronically (if they were issued in electronic format) or by writing legibly in non-erasable ink.

**2.2.12.3** The tenderer shall sign the original tender offer where required in terms of the Conditions of Tender. The tender shall be signed by a person duly authorised by the tenderer to do so. Tenders submitted by joint ventures of two or more firms shall be accompanied by the document of formation / founding document of the joint venture or any other document signed by all Parties, in which is defined precisely the conditions under which the joint venture will function, its period of duration, the persons authorised to represent and obligate it, the participation of the several firms forming the joint venture, and any other information necessary to permit a full appraisal of its functioning. Signatories for tenderers proposing to contract as joint ventures shall state which of the signatories is the lead partner.

**2.2.12.4** Where a two-envelope system is required in terms of the Conditions of Tender, place and seal the returnable documents listed in the Conditions of Tender in an envelope marked "financial proposal" and place the remaining returnable documents in an envelope marked "technical proposal". Each envelope shall state on the outside the CCT's address and identification details stated in the General Tender Information (i.e., item T.1 above), as well as the tenderer's name and contact address.

- 2.2.12.5** The tenderer shall seal the original tender offer and copy packages together in an outer package that states on the outside only the CCT's address and identification details as stated in the General Tender Information. . If it is not possible to submit the original tender and the required copies (see 2.2.12.3) in a single envelope, then the tenderer must seal the original and each copy of the tender offer as separate packages marking the packages as "ORIGINAL" and "COPY" in addition to the aforementioned tender submission details.
- 2.2.12.6** The CCT shall not assume any responsibility for the misplacement or premature opening of the tender offer if the outer package is not sealed and marked as stated.
- 2.2.12.7** Tender offers submitted by facsimile or e-mail will be rejected by the CCT, unless stated otherwise in the Conditions of Tender.
- 2.2.12.8** By signing the offer part of the Form of Offer (**Section 5, Part A hereto**) the tenderer warrants and agrees that all information provided in the tender submission is true and correct.
- 2.2.12.9** Tenderers shall properly deposit its bid in the designated tender box (as detailed on the front page of this tender document) on or before the closing date and before the closing time, in the relevant tender box at the Tender & Quotation Boxes Office situated on the 2nd floor, Concourse Level, Civic Centre, 12 Hertzog Boulevard, Cape Town. If the tender submission is too large to fit in the allocated box, please enquire at the public counter for assistance.
- 2.2.12.10** The tenderer must record and reference all information submitted contained in other documents for example cover letters, brochures, catalogues, etc. in the Returnable Schedule titled **List of Other Documents Attached by Tenderer**.

### **2.2.13 Information and data to be completed in all respects**

Tender offers, which do not provide all the data or information requested completely and in the form required, may be regarded by the CCT as non-responsive.

### **2.2.14 Closing time**

- 2.2.14.1** The tenderer shall ensure that the CCT receives the tender offer, together with all applicable documents specified herein, at the address specified in the General Tender Information herein prior to the closing time stated on the front page of the tender document.
- 2.2.14.2** If the CCT extends the closing time stated on the front page of the tender document for any reason, the requirements of these Conditions of Tender apply equally to the extended deadline.
- 2.2.14.3** The CCT shall not consider tenders that are received after the closing date and time for such a tender (late tenders).

### **2.2.15 Tender offer validity and withdrawal of tenders**

- 2.2.15.1** The tenderer shall warrant that the tender offer(s) remains valid, irrevocable and open for acceptance by the CCT at any time for a period of 120 days after the closing date stated on the front page of the tender document.
- 2.2.15.2** Notwithstanding the period stated in clause 2.2.15.1 above, bids shall remain valid for acceptance for a period of twelve (12) months after the expiry of the original validity period, unless the CCT is notified in writing of anything to the contrary by the bidder. The validity of bids may be further extended by a period of not more than six months subject to mutual agreement by the parties, administrative processes and upon approval by the City Manager, unless the required extension is as a result of an appeal process or court ruling.

In circumstances where the validity period of a tender has expired, and the tender has not been awarded, the tender process is considered "completed", despite there being no decision (award or cancellation) made. This anomaly does not fall under any of the listed grounds of cancellation and should be treated as a "non award". A "non award" is supported as a recommendation to the CCT's

Bod Adjudication Committee ("BAC") for noting.

**2.2.15.3** A tenderer may request in writing, after the closing date, that its tender offer be withdrawn. Such withdrawal will be permitted or refused at the sole discretion of the CCT after consideration of the reasons for the withdrawal, which shall be fully set out by the tenderer in such written request for withdrawal. Should the tender offer be withdrawn in contravention hereof, the tenderer agrees that:

- a) it shall be liable to the CCT for any additional expense incurred or losses suffered by the CCT in having either to accept another tender or, if new tenders have to be invited, the additional expenses incurred or losses suffered by the invitation of new tenders and the subsequent acceptance of any other tender;
- b) the CCT shall also have the right to recover such additional expenses or losses by set-off against monies which may be due or become due to the tenderer under this or any other tender or contract or against any guarantee or deposit that may have been furnished by the tenderer or on its behalf for the due fulfilment of this or any other tender or contract. Pending the ascertainment of the amount of such additional expenses or losses, the CCT shall be entitled to retain such monies, guarantee or deposit as security for any such expenses or loss, without prejudice to the CCT's other rights and/or remedies available to it in accordance with any applicable laws.

**2.2.16 Clarification of tender offer, or additional information, after submission**

Tenderer's shall promptly provide clarification of its tender offer, or additional information, in response to a written request to do so from the CCT during the evaluation of tender offers within the time period stated in such request. No change in the competitive position of tenderers or substance of the tender offer is sought, offered, or permitted.

Note: This clause does not preclude the negotiation of the final terms of the contract with a preferred tenderer following a competitive selection process, should the CCT elect to do so.

Failure, or refusal, to provide such clarification or additional information within the time for submission stated in the CCT's written request may render the tender non-responsive.

**2.2.17 Provide other material**

**2.2.17.1** Tenderer's shall promptly provide, upon request by the CCT, any other material that has a bearing on the tender offer, the tenderer's commercial position (including joint venture agreements), preferencing arrangements, or samples of materials, considered necessary by the CCT for the purpose of the evaluation of the tender. Should the tenderer not provide the material, or a satisfactory reason as to why it cannot be provided, by the time for submission stated in the CCT's request, the CCT may regard the tender offer as non-responsive.

**2.2.17.2** The tenderer shall provide, on written request by the CCT, where the transaction value inclusive of VAT **exceeds R 10 million**:

- a) audited annual financial statement for the past 3 years, or for the period since establishment if established during the past 3 years, if required by law to prepare annual financial statements for auditing;
- b) a certificate signed by the tenderer certifying that the tenderer has no undisputed commitments for municipal services towards a municipality or other service provider in respect of which payment is overdue for more than 30 days;
- c) particulars of any contracts awarded to the tenderer by an organ of state during the past five years, including particulars of any material non-compliance or dispute concerning the execution of such contract;
- d) a statement indicating whether any portion of the goods or services are expected to be sourced from outside the Republic, and, if so, what portion and whether any portion of payment from the municipality or municipal entity is expected to be transferred out of the Republic.

Each entity to a Consortium/Joint Venture bid shall submit separate certificates/statements in the above regard.

**2.2.17.3** Tenderers shall be required to undertake to fully cooperate with the CCT's external service provider appointed to perform a due diligence review and risk assessment upon receipt of such written instruction from the CCT.

### **2.2.18 Samples, Inspections, tests and analysis**

Tenderers shall provide access during working hours to premises for inspections, tests and analysis as provided for in the Conditions of Tender or Specifications.

If the Specifications requires the tenderer to provide samples, these shall be provided strictly in accordance with the instructions set out in the Specification.

If such samples are not submitted as required in the bid documents or within any further time stipulated by the CCT in writing, then the bid concerned may be declared non-responsive.

The samples provided by all successful bidders will be retained by the CCT for the duration of any subsequent contract. Bidders are to note that samples are requested for testing purposes therefore samples submitted to the CCT may not in all instances be returned in the same state of supply and in other instances may not be returned at all. Unsuccessful bidders will be advised by the Project Manager or dedicated CCT Official to collect their samples, save in the aforementioned instances where the samples would not be returned.

### **2.2.19 Certificates**

The tenderer must provide the CCT with all certificates as stated below:

#### **2.2.19.1. Preference Points for Specific Goals**

In order to qualify for preference points for Specific Goals, it is the responsibility of the tenderer to submit sufficient, relevant and verifiable documentary proof in support of any claim for preference points. Failure to submit adequate and verifiable evidence may result in the non-awarding of preference points claimed.

Tenderers are further referred to the Preference Schedule for the detailed methodology, scoring criteria, and conditions applicable to the allocation of preference points for Specific Goals.

#### **2.2.19.2 Evidence of tax compliance**

Tenderers shall be registered with the South African Revenue Service (SARS) and their tax affairs must be in order and they must be tax compliant subject to the requirements of clause 2.2.1.1.2.h. In this regard, it is the responsibility of the Tenderer to submit evidence in the form of a valid Tax Compliance Status PIN issued by SARS to the CCT at the Supplier Management Unit located within the Supplier Management / Registration Office, 2<sup>nd</sup> Floor (Concourse Level), Civic Centre, 12 Hertzog Boulevard, Cape Town (Tel 021 400 9242/3/4/5), or included with this tender. The tenderer must record its Tax Compliance Status PIN number on the **Details of Tenderer** pages of the tender submission.

Each party to a Consortium/Joint Venture shall submit a separate Tax Compliance Status Pin.

Before making an award the CCT must verify the bidder's tax compliance status. Where the recommended bidder is not tax compliant, the bidder should be notified of the non-compliant status and be requested to submit to the CCT, within 7 working days, written proof from SARS that they have made arrangement to meet their outstanding tax obligations. The proof of tax compliance submitted by the bidder must be verified by the CCT via CSD or e-Filing. The CCT should reject a bid submitted by the bidder if such bidder fails to provide proof of tax compliance within the timeframe stated herein.

Only foreign suppliers who have answered "NO" to all the questions contained in the Questionnaire to Bidding Foreign Suppliers section on the **Details of Tenderer** pages of the tender submission, are not required to register for a tax compliance status with SARS.

#### **2.2.20 Compliance with Occupational Health and Safety Act, 85 of 1993**

Tenderers are to note the requirements of the Occupational Health and Safety Act, 85 of 1993. The Tenderer shall be deemed to have read and fully understood the requirements of the above Act and Regulations and to

have allowed for all costs in compliance therewith.

In this regard the Tenderer shall submit **upon written request to do so by the CCT**, a Health and Safety Plan in sufficient detail to demonstrate the necessary competencies and resources to deliver the goods or services all in accordance with the Act, Regulations and Health and Safety Specification.

### **2.2.21 Claims arising from submission of tender**

By responding to the tender herein, the tenderer warrants that it has:

- a) Inspected the Specifications and read and fully understood the Conditions of Contract.
- b) Read and fully understood the whole text of the Specifications and Price Schedule and thoroughly acquainted himself with the nature of the goods or services proposed and generally of all matters which may influence the Contract.
- c) visited the site(s) where delivery of the proposed goods will take place, carefully examined existing conditions, the means of access to the site(s), the conditions under which the delivery is to be made, and acquainted himself with any limitations or restrictions that may be imposed by the Municipal or other Authorities in regard to access and transport of materials, plant and equipment to and from the site(s) and made the necessary provisions for any additional costs involved thereby.
- d) requested the CCT to clarify the actual requirements of anything in the Specifications and Price Schedule, the exact meaning or interpretation of which is not clearly intelligible to the Tenderer.
- e) Received any notices to the tender documents which have been issued in accordance with the CCT's Supply Chain Management Policy.

The CCT will therefore not be liable for the payment of any extra costs or claims arising from the submission of the tender.

### **2.2.22 Collection and issuing of tender documents**

The CCT will only issue tender documents through its Tender Distribution Office and/or the official CCT tender portal. Bidders who obtain documents through any means other than described herein, will not be known to the CCT and may thus not receive tender notices and addendums. Tenderers are not allowed to distribute tender documents to other potential bidders.

It is the responsibility of bidders who obtain documents through any means other than described herein, to notify the CCT tender representative thereof that they are participating in the tender. The CCT accepts no liability for any tender notices or addendums not reaching any bidders, who obtained documents through any means other than described herein or who provided incorrect contact details to the CCT.

## **2.3 The CCT's undertakings**

### **2.3.1 Respond to requests from the tenderer**

**2.3.1.1** Unless otherwise stated in the Conditions of Tender, the CCT shall respond to a request for clarification received up to one week (where possible) before the tender closing time stated on the front page of the tender document.

**2.3.1.2** The CCT's duly authorised representative for the purpose of this tender is stated on the General Tender Information page above.

### **2.3.2 Issue Notices**

If necessary, the CCT may issue addenda in writing that may amend or amplify the tender documents to each tenderer during the period from the date the tender documents are available until one week before the tender closing time stated in the Tender Data. The CCT reserves its rights to issue addenda less than one week before the tender closing time in exceptional circumstances. If, as a result a tenderer applies for an extension to the closing time stated on the front page of the tender document, the CCT may grant such extension and, shall then notify all tenderers who drew documents.

Notwithstanding any requests for confirmation of receipt of notices issued, the tenderer shall be deemed to have received such notices if the CCT can show proof of transmission thereof via electronic mail, facsimile or registered post.

**2.3.3 Opening of tender submissions**

**2.3.3.1** Unless the two-envelope system is to be followed, CCT shall open tender submissions in the presence of tenderers' agents who choose to attend at the time and place stated in the Conditions of Tender.

Tenders will be opened immediately after the closing time for receipt of tenders as stated on the front page of the tender document, or as stated in any Notice extending the closing date and at the closing venue as stated in the General Tender Information.

**2.3.3.2** Announce at the meeting held immediately after the opening of tender submissions, at the closing venue as stated in the General Tender Information, the name of each tenderer whose tender offer is opened and, where possible, the prices indicated.

**2.3.3.3** Make available a record of the details announced at the tender opening meeting on the CCT's website (<http://www.capetown.gov.za/en/SupplyChainManagement/Pages/default.aspx>.)

**2.3.4 two-envelope system**

**2.3.4.1** Where stated in the Conditions of Tender that a two-envelope system is to be followed, the CCT shall open only the technical proposal of tenders in the presence of tenderers' agents who choose to attend at the time and place stated in the Conditions of Tender and announce the name of each tenderer whose technical proposal is opened.

**2.3.4.2** The CCT shall evaluate the quality of the technical proposals offered by tenderers, then advise tenderers who have submitted responsive technical proposals of the time and place when the financial proposals will be opened. The CCT shall open only the financial proposals of tenderers, who have submitted responsive technical proposals in accordance with the requirements as stated in the Conditions of Tender, and announce the total price and any preference claimed. Return unopened financial proposals to tenderers whose technical proposals were non responsive.

**2.3.5 Non-disclosure**

The CCT shall not disclose to tenderers, or to any other person not officially concerned with such processes, information relating to the evaluation and comparison of tender offers and recommendations for the award of a contract, until after the award of the contract to the successful tenderer.

**2.3.6 Grounds for rejection and disqualification**

The CCT shall determine whether there has been any effort by a tenderer to influence the processing of tender offers and instantly disqualify a tenderer (and his tender offer) if it is established that he engaged in corrupt or fraudulent practices.

**2.3.7 Test for responsiveness**

**2.3.7.1** Appoint a Bid Evaluation Committee and determine after opening whether each tender offer properly received:

- a) complies with the requirements of these Conditions of Tender,
- b) has been properly and fully completed and signed, and
- c) is responsive to the other requirements of the tender documents.

**2.3.7.2** A responsive tender is one that conforms to all the terms, conditions, and specifications of the tender documents without material deviation or qualification. A material deviation or qualification is one which, in the CCT's opinion, would:

- a) Detrimentially affect the scope, quality, or performance of the goods, services or supply identified in the Specifications,
- b) Significantly change the CCT's or the tenderer's risks and responsibilities under the contract,
- or
- c) affect the competitive position of other tenderers presenting responsive tenders, if it were to

be rectified.

Reject a non-responsive tender offer, and not allow it to be subsequently made responsive by correction or withdrawal of any material deviation or qualification.

The CCT reserves the right to accept a tender offer which does not, in the CCT's opinion, materially and/or substantially deviate from the terms, conditions, and specifications of the tender documents.

### **2.3.8 Arithmetical errors, omissions and discrepancies**

#### **2.3.8.1** Check the responsive tenders for:

- a) The gross misplacement of the decimal point in any unit rate;
- b) Omissions made in completing the Price Schedule; or
- c) Arithmetic errors in:
  - i) line item totals resulting from the product of a unit rate and a quantity in the Price Schedule; or
  - ii) The summation of the prices; or
  - iii) Calculation of individual rates.

#### **2.3.8.2** The CCT must correct the arithmetical errors in the following manner:

- a) Where there is a discrepancy between the amounts in words and amounts in figures, the amount in words shall govern.
- b) If pricing schedules apply and there is an error in the line item total resulting from the product of the unit rate and the quantity, the line item total shall govern and the rate shall be corrected. Where there is an obviously gross misplacement of the decimal point in the unit rate, the line item total as tendered shall govern, and the unit rate shall be corrected.
- c) Where there is an error in the total of the prices either as a result of other corrections required by this checking process or in the tenderer's addition of prices, the total of the prices shall govern and the tenderer will be asked to revise selected item prices (and their rates if Price Schedules apply) to achieve the tendered total of the prices.

Consider the rejection of a tender offer if the tenderer does not correct or accept the correction of the arithmetical error in the manner described above.

#### **2.3.8.3** In the event of tendered rates or lump sums being declared by the CCT to be unacceptable to it because they are not priced, either excessively low or high, or not in proper balance with other rates or lump sums, the tenderer may be required to produce evidence and advance arguments in support of the tendered rates or lump sums objected to. If, after submission of such evidence and any further evidence requested, the CCT is still not satisfied with the tendered rates or lump sums objected to, it may request the tenderer to amend these rates and lump sums along the lines indicated by it.

The tenderer will then have the option to alter and/or amend the rates and lump sums objected to and such other related amounts as are agreed on by the CCT, but this shall be done without altering the tender offer in accordance with this clause.

Should the tenderer fail to amend his tender in a manner acceptable to and within the time stated by the CCT, the CCT may declare the tender as non-responsive.

### **2.3.9 Clarification of a tender offer**

The CCT may, after the closing date, request additional information or clarification from tenderers, in writing on any matter affecting the evaluation of the tender offer or that could give rise to ambiguity in a contract arising from the tender offer, which written request and related response shall not change or affect their competitive position or the substance of their offer. Such request may only be made in writing by the Director: Supply Chain Management using any means as appropriate.

## 2.3.10 Evaluation of tender offers

### 2.3.10.1 General

**2.3.10.1.1** The CCT may reduce each responsive tender offer to a comparative price and evaluate them using the tender evaluation methods and associated evaluation criteria and weightings that are specified in the Conditions of Tender.

**2.3.10.1.2** For evaluation purposes only, the effects of the relevant contract price adjustment methods will be considered in the determination of comparative prices as follows:

- a) If the selected method is based on bidders supplying rates or percentages for outer years, comparative prices would be determined over the entire contract period based on such rates or percentages.
- b) If the selected method is based on a formula, indices, coefficients, etc. that is the same for all bidders during the contract period, comparative prices would be the prices as tendered for year one.
- c) If the selected method is based on a formula, indices, coefficients, etc. that varies between bidders, comparative prices would be determined over the entire contract period based on published indices relevant during the 12 months prior to the closing date of tenders.
- d) If the selected method includes an imported content requiring rate of exchange variation, comparative prices would be determined based on the exchange rates tendered for the prices as tendered for year one. The rand equivalent of the applicable currency 14 days prior to the closing date of tender will be used (the CCT will check all quoted rates against those supplied by its own bank).
- e) If the selected method is based on suppliers' price lists, comparative prices would be the prices as tendered for year one.
- f) If the selected method is based on suppliers' price lists and / or rate of exchange, comparative prices would be determined as tendered for year one whilst taking into account the tendered percentage subject to rate of exchange (see sub clause (d) for details on the calculation of the rate of exchange).

**2.3.10.1.3** Where the scoring of functionality forms part of a bid process, each member of the Bid Evaluation Committee must individually score functionality. The individual scores must then be interrogated and calibrated if required where there are significant discrepancies. The individual scores must then be added together and averaged to determine the final score.

### 2.3.10.2 Decimal places

Score financial offers, preferences and functionality, as relevant, to two decimal places.

### 2.3.10.3 Scoring of tenders (price and preference)

**[2.3.10.3.1** Points for price will be allocated in accordance with the formula set out in this clause based on the price per item / rates as set out in the **Price Schedule (Section 7)**:

- Based on the sum of the prices/rates in relation to a typical project/job.]

**2.3.10.3.2** Points for preference will be allocated in accordance with the provisions of **Preference Schedule** and the table in this clause.

**2.3.10.3.3** The terms and conditions of **Preference Schedule** as it relates to preference shall apply in all respects to the tender evaluation process and any subsequent contract.

**2.3.10.3.4** Applicable formula:

The 90/10 price/preference points system will be applied to the evaluation of responsive tenders above a Rand value of R50'000'000 (all applicable taxes included), whereby the order(s) will be placed with the tenderer(s) scoring the highest total number of adjudication points.

Price shall be scored as follows:

$$P_s = 90 \times \left(1 - \frac{(P_t - P_{min})}{P_{min}}\right)$$

Where: Ps is the number of points scored for price;  
 Pt is the price of the tender under consideration;  
 Pmin is the price of the lowest responsive tender.

Preference points shall be based on the Specific Goal as per below:

**Table B2: Awards above R50 mil (VAT Inclusive)**

#	Specific goals allocated points	Preference Points (90/10)
	<b>Reconstruction and Development Programme (RDP) as published in Government Gazette</b>	
1	<b>Promotion of Micro and Small Enterprises</b> <b>Micro with a turnover up to R20million and Small with a turnover up to R80 million as per National Small Enterprise Act, 1996 (Act No.102 of 1996)</b> <b>SME partnership, sub-contracting, joint venture or consortiums</b>	4
2	<b>Enterprise Supplier Development and Socio Economic Development</b>  > 15% of total expenditure = 3 points > 10% up to 15% of total expenditure = 2 points >= 5% up to 10% of total expenditure = 1 points < 5% of total expenditure = 0 points	3
3	<b>Skills Development OR Employee Share Scheme</b> <b>Skills Development</b> > 5% of total profit = 3 points > 3% up to 5% of total profit = 2 points >= 1% up to 3% of total profit = 1 points < 1% of total profit = 0 points  <b>OR Employee Share Scheme</b> > 15% employee ownership = 3 points > 10% up to 15% employee ownership = 2 point >= 5% up to 10% employee ownership = 1 point < 5% employee ownership = 0 point	3
	<b>Total points</b>	<b>10</b>

**2.3.10.5 Risk Analysis**

Notwithstanding compliance with regard to any requirements of the tender, the CCT will perform a risk analysis in respect of the following:

- a) reasonableness of the financial offer
- b) reasonableness of unit rates and prices
- c) the tenderer's ability to fulfil its obligations in terms of the tender document, that is, that the tenderer can demonstrate that he/she possesses the necessary professional and technical qualifications, professional and technical competence, financial resources, equipment and other physical facilities, managerial capability, reliability, capacity, experience, reputation, personnel to perform the contract, etc.; the CCT reserves the right to consider a tenderer's existing contracts with the CCT in this regard
- d) any other matter relating to the submitted bid, the tendering entity, matters of compliance, verification of submitted information and documents, etc.

The conclusions drawn from this risk analysis will be used by the CCT in determining the acceptability of the tender offer.

No tenderer will be recommended for an award unless the tenderer has demonstrated to the satisfaction of the CCT that he/she has the resources and skills required.

**2.3.11 Negotiations with preferred tenderers**

The CCT may negotiate the final terms of a contract with tenderers identified through a competitive tendering process as preferred tenderers provided that such negotiation:

- a) Does not allow any preferred tenderer a second or unfair opportunity;
- b) Is not to the detriment of any other tenderer; and
- c) Does not lead to a higher price than the tender as submitted.

If negotiations fail to result in acceptable contract terms, the City Manager (or his delegated authority) may terminate the negotiations and cancel the tender, or invite the next ranked tenderer for negotiations. The original preferred tenderer should be informed of the reasons for termination of the negotiations. If the decision is to invite the next highest ranked tenderer for negotiations, the failed earlier negotiations may not be reopened by the CCT.

Minutes of any such negotiations shall be kept for record purposes.

The provisions of this clause will be equally applicable to any invitation to negotiate with any other tenderers.

In terms of the CCT's SCM Policy, tenders must be cancelled in the event that negotiations fail to achieve a market related price with any of the three highest scoring tenderers.

**2.3.12 Acceptance of tender offer**

Notwithstanding any other provisions contained in the tender document, the CCT reserves the right to:

**2.3.12.1** Accept a tender offer(s) which does not, in the CCT's opinion, materially and/or substantially deviate from the terms, conditions, and specifications of the tender document.

**2.3.12.2** Accept the whole tender or part of a tender or any item or part of any item or items from multiple manufacturers, or to accept more than one tender (in the event of a number of items being offered), and the CCT is not obliged to accept the lowest or any tender.

**2.3.12.3** Accept the tender offer(s), if in the opinion of the CCT, it does not present any material risk and only if the tenderer(s):

- a) is not under restrictions, has any principals who are under restrictions, or is not currently a supplier to whom notice has been served for abuse of the supply chain management system, preventing participation in the CCT's procurement,
- b) can, as necessary and in relation to the proposed contract, demonstrate that he or she possesses the professional and technical qualifications, professional and technical

competence, financial resources, equipment and other physical facilities, managerial capability, reliability, experience and reputation, expertise and the personnel, to perform the contract,

- c) has the legal capacity to enter into the contract,
- d) is not insolvent, in receivership, under Business Rescue as provided for in chapter 6 of the Companies Act, 2008, bankrupt or being wound up, has his affairs administered by a court or a judicial officer, has suspended his business activities, or is subject to legal proceedings in respect of any of the foregoing, complies with the legal requirements, if any, stated in the tender data, and
- e) is able, in the opinion of the CCT, to perform the contract free of conflicts of interest.

If an award cannot be made in terms of anything contained herein, the CCT reserves the right to consider the next ranked tenderer(s).

**2.3.12.4** The CCT reserves the right not to make an award, or revoke an award already made, where the implementation of the contract may result in reputational risk or harm to the CCT as a result of (inter alia):

- a) reports of poor governance or unethical behaviour, or both;
- b) association with known notorious individuals and family of notorious individuals;
- c) poor performance issues, known to the CCT;
- d) negative media reports, including negative social media reports;
- e) adverse assurance (e.g. due diligence) report outcomes; and
- f) circumstances where the relevant vendor has employed, or is directed by, anyone who was previously employed in the service of the state (as defined in clause 1.53 of the SCM Policy), where the person is or was negatively implicated in any SCM irregularity.

**2.3.12.5** The CCT reserves the right to nominate a Standby Bidder at the time when an award is made and in the event that a contract is terminated during the execution thereof, the CCT may consider the award of the contract, or non-award, to the Standby Bidder in terms of the procedures included in its SCM Policy.

### **2.3.13 Prepare contract documents**

**2.3.13.1** If necessary, revise documents that shall form part of the contract and that were issued by the CCT as part of the tender documents to take account of:

- a) Notices issued during the tender period,
- b) Inclusion of some of the returnable documents, and
- c) Other revisions agreed between the CCT and the successful tenderer.

**2.3.13.2 Complete** the schedule of deviations attached to the form of offer and acceptance, if any.

### **2.3.14 Notice to successful and unsuccessful tenderers**

**2.3.14.1** Before accepting the tender of the successful tenderer the CCT shall notify the successful tenderer in writing of the decision of the CCT's Bid Adjudication Committee to award the tender to the successful tenderer. No rights shall accrue to the successful tenderer in terms of this notice

**2.3.14.2** The CCT shall, at the same time as notifying the successful tenderer of the Bid Adjudication Committee's decision to award the tender to the successful tenderer, also give written notice to the other tenderers informing them that they have been unsuccessful.

### **2.3.15 Provide written reasons for actions taken**

Provide upon request written reasons to tenderers for any action that is taken in applying these Conditions of Tender, but withhold information which is not in the public interest to be divulged, which is considered to prejudice the legitimate commercial interests of tenderers or might prejudice fair competition between tenderers.

<b>TENDER DOCUMENT GOODS AND SERVICES</b>		 CITY OF CAPE TOWN ISIXEKO SASEKAPA STAD KAAPSTAD
<b>SUPPLY CHAIN MANAGEMENT</b>		
SCM - 542	Approved by Branch Manager: February 2024	Version: 10   Page 22 of 80

<p><b>TENDER NO: 2G/2026/27</b></p> <p><b>TENDER DESCRIPTION: [TERM TENDER OF THE SUPPLY AND DELIVERY, INSTALLATION OF NEW OUTDOOR EXERCISE EQUIPMENT AND THE REPAIRS TO EXISTING OUTDOOR EXERCISE EQUIPMENT]</b></p> <p><b>CONTRACT PERIOD: [36] MONTHS FROM THE COMMENCEMENT DATE OF THE CONTRACT</b></p>
---

**THE CONTRACT**

<b>THE CITY OF CAPE TOWN</b>	
A metropolitan municipality, established in terms of the Local Government: Municipal Structures Act, 117 of 1998 read with the Province of the Western Cape: Provincial Gazette 5588 dated 22 September 2000, as amended ("the Purchaser") herein represented by	
<b>AUTHORISED REPRESENTATIVE</b>	

AND

<b>SUPPLIER</b>	
<b>NAME of Company/Close Corporation or Partnership / Joint Venture/ Consortium or Sole Proprietor /Individual (The "Supplier" / "tenderer")</b>	
<b>TRADING AS</b> (if different from above)	
<b>REGISTRATION NUMBER</b>	
<b>PHYSICAL ADDRESS / CHOSEN DOMICILIUM CITANI ET EXECTUANDI OF THE SUPPLIER</b>	
<b>AUTHORISED REPRESENTATIVE</b>	
<b>CAPACITY OF AUTHORISED REPRESENTATIVE</b>	

(HEREINAFTER COLLECTIVELY REFERRED TO AS "THE PARTIES" AND INDIVIDUALLY A "PARTY")

<b>NATURE OF TENDER OFFER</b> (please indicate below)	
<b>Main Offer</b> (see clause 2.2.11.1)	
<b>Alternative Offer</b> (see clause 2.2.11.1)	



**C.2 FORM OF OFFER AND ACCEPTANCE**

**TENDER [2G/2026/27 : TERM TENDER OF THE SUPPLY AND DELIVERY, INSTALLATION OF NEW OUTDOOR EXERCISE EQUIPMENT AND THE REPAIRS TO EXISTING OUTDOOR EXERCISE EQUIPMENT]**

**C.2.1 Offer (To Be Completed by the Tenderer as Part of Tender Submission)**

The tenderer, identified in the offer signature table below,

**HEREBY AGREES THAT** by signing the *Form of Offer and Acceptance*, the tenderer:

1. confirms that it has examined the documents listed in the Index (including Schedules and Annexures) and has accepted all the Conditions of Tender;
2. confirms that it has received and incorporated any and all notices issued to tenderers issued by the CCT;
3. confirms that it has satisfied itself as to the correctness and validity of the tender offer; that the price(s) and rate(s) offered cover all the goods and/or services specified in the tender documents; that the price(s) and rate(s) cover all its obligations and accepts that any mistakes regarding price(s), rate(s) and calculations will be at its own risk;
4. offers to supply all or any of the goods and/or render all or any of the services described in the tender document to the CCT in accordance with the:
  - 4.1 terms and conditions stipulated in this tender document;
  - 4.2 specifications stipulated in this tender document; and
  - 4.3 at the prices as set out in the **Price Schedule**.
5. accepts full responsibility for the proper execution and fulfilment of all obligations and conditions devolving on it in terms of the Contract.

SIGNED AT \_\_\_\_\_ (PLACE) ON THE \_\_\_\_ (DAY) OF \_\_\_\_\_ (MONTH AND YEAR)

\_\_\_\_\_  
 For and on behalf of the Supplier  
 (Duly Authorised)  
 Name and Surname:

\_\_\_\_\_  
 Witness 1 Signature  
 Name and Surname:

\_\_\_\_\_  
 Witness 2 Signature  
 Name and Surname:

INITIALS OF CCT OFFICIALS		
1	2	3

<b>FORM OF OFFER AND ACCEPTANCE (continued)</b>
---

**TENDER [2G/2026/27 : TERM TENDER OF THE SUPPLY AND DELIVERY,  
INSTALLATION OF NEW OUTDOOR EXERCISE EQUIPMENT AND THE  
REPAIRS TO EXISTING OUTDOOR EXERCISE EQUIPMENT]**

**C.2.2 Acceptance (To Be Completed by the CCT)**

By signing this part of this *Form of Offer and Acceptance*, the CCT accepts the tenderer's (if awarded the Supplier's) offer. In consideration thereof, the CCT shall pay the Supplier the amount due in accordance with the conditions of contract. Acceptance of the Supplier's offer shall form an agreement between the CCT and the Supplier upon the terms and conditions contained in this document.

The terms of the agreement are contained in the Contract (as defined) including drawings and documents or parts thereof, which may be incorporated by reference.

Deviations from and amendments to the documents listed in the tender data and any addenda thereto as listed in the *Tender Returnable Documents* as well as any changes to the terms of the offer agreed by the tenderer and the CCT during this process of offer and acceptance, are contained in the *Schedule of Deviations* attached to and forming part of this *Form of Offer and Acceptance*. No amendments to or deviations from said documents are valid unless contained in the *Schedule of Deviations*.

The Supplier shall within 2 (two) weeks after receiving a complete, copy of the Contract, including the *Schedule of Deviations* (if any), contact the CCT to arrange the delivery of any securities, bonds, guarantees, proof of insurance and any other documents to be provided in terms the *Special Conditions of Contract*. Failure to fulfil any of these obligations in accordance with those terms shall constitute a repudiation / breach of the agreement.

Notwithstanding anything contained herein, this agreement comes into effect on the Commencement Date, being the date upon which the Supplier confirms receipt from the CCT of 1 (one) complete, signed copy of the Contract, including amendments or deviations contained in the *Schedule of Deviations* (if any).

\_\_\_\_\_  
For and on behalf of the City of Cape Town  
(Duly Authorised)  
Name and Surname:

\_\_\_\_\_  
Witness 1 Signature  
Name and Surname:

\_\_\_\_\_  
Witness 2 Signature  
Name and Surname:

**FORM OF OFFER AND ACCEPTANCE (continued)**

**TENDER [2G/2026/27 : TERM TENDER OF THE SUPPLY AND DELIVERY, INSTALLATION OF NEW OUTDOOR EXERCISE EQUIPMENT AND THE REPAIRS TO EXISTING OUTDOOR EXERCISE EQUIPMENT]**

**C.2.3 Schedule of Deviations (To be Completed by the CCT upon Acceptance)**

**Notes:**

1. The extent of deviations from the tender documents issued by the CCT before the tender closing date, is limited to those permitted in terms of the conditions of tender.
2. A tenderer's covering letter shall not be included in the final Contract document. Should any matter in such letter, which constitutes a deviation as aforesaid, become the subject of agreements reached during the process of offer and acceptance, the outcome of such agreement shall be recorded here.
3. Any other matter arising from the process of offer and acceptance either as a confirmation, clarification or change to the tender documents and which it is agreed by the Parties to become an obligation of the Contract, shall be recorded here.
4. Any change or addition to the tender documents arising from the above agreements and recorded here, shall form part of the Contract.

1 Subject .....

Details .....

.....

.....

.....

2 Subject .....

Details .....

.....

.....

.....

3 Subject .....

Details .....

.....

.....

.....

4 Subject .....

Details .....

.....

.....

.....

By the duly authorised representatives signing this agreement, the CCT and the tenderer agree to and accept the foregoing schedule of deviations as the only deviations from and amendments to this tender document and addenda thereto as listed in the *Tender Returnable Documents*, as well as any confirmation, clarification or changes to the terms of the offer agreed by the tenderer and the CCT during this process of offer and acceptance.

It is expressly agreed that no other matter whether in writing, oral communication or implied during the period between the issue of the tender documents and the Commencement Date, shall have any meaning or effect between the Parties arising from the agreement.

**FORM OF OFFER AND ACCEPTANCE (continued)**

**TENDER [2G/2026/27 : TERM TENDER OF THE SUPPLY AND DELIVERY, INSTALLATION OF NEW OUTDOOR EXERCISE EQUIPMENT AND THE REPAIRS TO EXISTING OUTDOOR EXERCISE EQUIPMENT]**

**C.2.4 Confirmation of Receipt (To be Completed by Supplier upon Acceptance)**

The Supplier identified in the offer part of the Contract hereby confirms receipt from the CCT of 1 (one) complete, signed copy of the Contract, including the *Schedule of Deviations* (if any) on:

The..... (Day)

Of..... (Month)

20..... (year)

At..... (Place)

For the Supplier: Signature(s) .....

Name(s) .....

Capacity .....

Signature and name of witness:

Signature ..... Name .....

**C.3 OCCUPATIONAL HEALTH AND SAFETY AGREEMENT**

**AGREEMENT MADE AND ENTERED INTO BETWEEN THE CCT (HEREINAFTER CALLED THE "CCT")  
AND**

.....  
(Supplier/Mandatory/Company/CC Name)

**IN TERMS OF SECTION 37(2) OF THE OCCUPATIONAL HEALTH AND SAFETY ACT, 85 OF 1993 AS AMENDED.**

I, ....., representing

....., as an employer in its own right in its own right, do hereby undertake to ensure, as far as is reasonably practicable, that all work will be performed, and all equipment, machinery or plant used in such a manner as to comply with the provisions of the Occupational Health and Safety Act ( hereafter "OHSA") and the Regulations promulgated thereunder.

I furthermore confirm that I am/we are registered with the Compensation Commissioner and that all registration and assessment monies due to the Compensation Commissioner have been fully paid or that I/We are insured with an approved licensed compensation insurer.

COID ACT Registration Number: .....

OR Compensation Insurer: ..... Policy No.: .....

I undertake to appoint, where required, suitable competent persons, in writing, in terms of the requirements of OHSA and the Regulations and to charge him/them with the duty of ensuring that the provisions of OHSA and Regulations as well as the Council's Special Conditions of Contract, Way Leave, Lock-Out and Work Permit Procedures are adhered to as far as reasonably practicable.

I further undertake to ensure that any subcontractors employed by me will enter into an occupational health and safety agreement separately, and that such subcontractors comply with the conditions set.

I hereby declare that I have read and understand the Occupational Health and Safety Specifications contained in this tender and undertake to comply therewith at all times.

I hereby also undertake to comply with the Occupational Health and Safety Specification and Plan submitted and approved in terms thereof.

Signed at .....on the.....day of.....20....

\_\_\_\_\_  
**Witness**

\_\_\_\_\_  
**Mandatory**

Signed at..... on the.....day of.....20 ....

\_\_\_\_\_  
Witness

\_\_\_\_\_  
for and on behalf of  
CCT

<b>C.4 PRICE SCHEDULE</b>
---------------------------

Bid specifications may not make any reference to any particular trade mark, name, patent, design, type, specific origin or producer, unless there is no other sufficiently precise or intelligible way of describing the characteristics of the work, in which case such reference must be accompanied by the words "or equivalent".

**TENDERERS MUST NOTE THAT WHEREVER THIS DOCUMENT REFERS TO ANY PARTICULAR TRADE MARK, NAME, PATENT, DESIGN, TYPE, SPECIFIC ORIGIN OR PRODUCER, SUCH REFERENCE SHALL BE DEEMED TO BE ACCOMPANIED BY THE WORDS 'OR EQUIVALENT'**

TERM TENDER OF THE SUPPLY AND DELIVERY, INSTALLATION OF NEW OUTDOOR EXERCISE EQUIPMENT AND THE REPAIRS TO EXISTING OUTDOOR EXERCISE EQUIPMENT				
Item No.	Item	Description	Unit of Measure	Rate (Exclusive Vat)
<b>GYM EQUIPMENT SUPPLY AND INSTALL SECTION</b>				
1.1	<i>Twin Walker : According to Drawing No. 01 and item 6.15 under specification)</i>	a) Supply and delivery of equipment	each	
		b) Installation of equipment, only	each	
1.3	<i>Double Walker: According to Drawing No. 02 and item 6.15 under specification)</i>	a) <i>Supply and delivery of equipment</i>	<i>each</i>	
		b) <i>Installation of equipment, only</i>	<i>each</i>	
1.4	<i>Push Up Frame: According to Drawing No. 03 and item 6.15 under specification</i>	a) Supply and delivery of equipment	each	
		b) Installation of equipment, only	each	
1.6	<i>Double Twister: According to Drawing No. 04 and item 6.15 under specification</i>	a) Supply and delivery of equipment	each	
1.7		b) Installation of equipment, only]	each	
1.8	<i>Twin Tai-chi Wheel: According to Drawing No. 05 and item 6.15 under specification)</i>	a) Supply and delivery of equipment	each	
1.9		b) Installation of equipment, only]	each	
1.10	<i>Twin Push Chair: According to Drawing No. 06 and item 6.15 under specification)</i>	a) Supply and delivery of equipment	each	
1.11		b) Installation of equipment, only]	each	

1.12	Twin Pull Up Chair: <i>According to Drawing No. 07 and item 6.11 under specification)</i>	a) Supply and delivery of equipment	each	
1.13		b) Installation of equipment, only]	each	
1.14	Twin Side Twister: <i>According to Drawing No. 08 and item 6.11 under specification)</i>	a) Supply and delivery of equipment	each	
1.15		b) Installation of equipment, only]	each	
1.16	Bicycle: <i>According to Drawing No. 9 and item 6.11 under specification)</i>	a) Supply and delivery of equipment	each	
1.17		b) Installation of equipment, only]	each	
1.18	Elliptical Cross Trainer: <i>According to Drawing No. 10 and item 6.11 under specification)</i>	a) Supply and delivery of equipment	each	
1.19		b) Installation of equipment, only]	each	
1.20	Rowing Machine: <i>According to Drawing No. 11 and item 6.11 under specification)</i>	a) Supply and delivery of equipment	each	
1.21		b) Installation of equipment, only]	each	
1.22	Monkey Frame: <i>According to Drawing No. 12 and item 6.15 under specification)</i>	a) Supply and delivery of equipment	each	
1.23		b) Installation of equipment, only]	each	
1.24	Balancing Beam: <i>According to Drawing No. 13 and item 6.15 under specification)</i>	a) Supply and delivery of equipment	each	
1.25		b) Installation of equipment, only]	each	
1.26	Sit Up Frame: <i>According to Drawing No. 14 and item 6.11 under specification)</i>	a) Supply and delivery of equipment	each	
1.27		b) Installation of equipment, only]	each	
1.28	4-in1 Machine: <i>According to Drawing No. 15 and item 6.11 under specification)</i>	a) Supply and delivery of equipment	each	
1.29		b) Installation of equipment, only]	each	
1.30	Circuit information board	All outdoor exercise equipment must be supplied in accordance with specification ref drawing	each	

		no.09		
1.31	Instruction panel	All outdoor exercise equipment must be supplied in accordance with specification ref drawing no.01 to 14	each	
1.32	Quality Control report.	Quality assurance report by external independent party for each projects which will include all items of the project.	each	
1.33	Professional Services	Structural Engineer	Per Hr	
1.34	Professional Services	Civil Engineer	Per Hr	
1.35	Professional Services	Mechanical Engineer	Per Hr	
1.36	Professional Services	Landscape Architech	Per Hr	
1.37	Professional Services	Geotechnical Engineer	Per Hr	
1.38	Professional Services	Contractors Mark-up on Professional Services	%	
1.39	Professional Services	Provide recommendations for remedial actions based on the COC technical assessment of the engineer	Sum	
1.40	Professional Services	Furnished offices	Sum	
1.41	Professional Services	Telephone	Sum	
1.42	Professional Services	Nameboards and monthly progress photos	Sum	
1.43	Professional Services	Detail Designed of Drawing No 1 – 15 (as required)	Per Hr	
<b>GYM EQUIPMENT REPAIR AND MAINTENANCE SECTION</b>				
2.1	Item 1: Twin Walker	Removal & Re-Installation	each	
2.2		Replacement of Baseplates (price per plate)	each	

2.3		Replacement of footplate (price per plate)	each		
2.4		Replacement of Pipe (48.50mm) (price per meter)	each		
2.5		Replacement of Shaft	each		
2.6		Replacement of Pipe (60mm) (price per meter)	each		
2.7		Replacement of 165mm post	each		
2.8		Refurbishment	each		
2.9		Stripping and Painting	each		
2.10		Replacement of 165mm end cover	each		
2.11		Replacement of hinge support	each		
2.12		Replacement of pivot nut	each		
2.13		Replacement of stiffener	each		
2.14		Replacement of collar base twister	each		
2.15		Replacement of bearings	each		
2.16		Replacement of bearing cover	each		
2.17		Replacement of foot stiffener	each		
2.18		Servicing of Items 2.1 – 2.17	each		
3.1		Item 2: Double Walker	Removal & Re-Installation	each	
3.2			Replacement of Baseplates (price per plate)	each	
3.3	Replacement of footplate (price per plate)		each		

3.4		Replacement of foot beam	each		
3.5		Replacement of pipe(42,30mm)price per meter	each		
3.6		Replacement of Pipe (60mm) (price per meter)	each		
3.7		Replacement of pivot bush	each		
3.8		Replacement of spacer	each		
3.9		Stripping and Painting	each		
3.10		Replacement of lower pivot shaft	each		
3.11		Replacement of bearings	each		
3.12		Replacement of bearing cover	each		
3.13		Replacement of 165mm end cover	each		
3.14		Replacement of top pivot shaft	each		
3.15		Replacement of end washer	each		
3.16		Replacement of lower bearing ends	each		
3.17		Replacement of pivot support	each		
3.18		Replacement of lower pivot shaft	each		
3.19		Servicing of Items 3.1 – 3.18	each		
4.1		Item 3: Twin Push Up Frame	Removal & Re-Installation	each	
4.2			Replacement of Base Plate	each	
4.3			Replacement of Pipe (165 x 4,5 mm) (price per meter)	each	

4.4		Replacement of instruction panel	each		
4.5		replacement of hand base	each		
4.6		Replacement of Pipe (50mm) (price per meter)	each		
4.7		Replacement of collar brace	each		
4.8		Refurbishment	each		
4.9		Stripping and Painting	each		
4.10		Replacement of 165mm end cover	each		
4.11		Replacement of M10 hex nuts	each		
4.12		Powder Coating	each		
4.13		Wooden Seat / Back Support	each		
4.14		Fibreglass Seat / Back Support	each		
4.15		Servicing of Items 4.1 – 4.14	each		
5.1		Item 4: Double Twister	Removal & Re-Installation	each	
5.2			Replacement of Baseplate	each	
5.3			Replacement of Tapered Roller Bearing (price per bearing)	each	
5.4	Replacement of Pipe (48.50mm) (price per meter)		each		
5.5	Replacement of Circular plate (price per plate)		each		
5.6	Replacement of Pipe (60mm) (price per meter)		each		
5.7	Replacement of Rubber Discs (price per Disc)		each		

5.8		Refurbishment	each	
5.9		Stripping and Painting	each	
5.10		Replacement of 165mm post	each	
5.11		Replacement of twister base collar	each	
5.12		replacement of 165mm end cover	each	
5.13		Replacement of twisting shaft mechanism	each	
5.14		Replacement of top collar	each	
5.15		Replacement of arm brace	each	
5.16		Replacement of M10 hex nuts	each	
5.17		Powder Coating	each	
5.18		Servicing of Items 5.1 – 5.17	each	
6.1	Item 5: Twin Tai-chi Wheel	Removal & Re-Installation	each	
6.2		Replacement of Baseplate	each	
6.3		Replacement of 165mm post	each	
6.4		Replacement of Pipe (42.30mm) (price per meter)	each	
6.5		Replacement of Tai-chi wheels(price per wheel)	each	
6.6		Replacement of Pipe (50mm) (price per meter)	each	
6.7		Replacement of Rubber Discs (price per Disc)	Each	
6.8		Refurbishment	Each	

6.9		Stripping and Painting	Each	
6.10		Replacement of 165mm end cover replacement of handle	Each	
6.11		Replacement of arm brace	Each	
6.12		Replacement of support bars	Each	
6.13		Replacement of stiffener	Each	
6.14		Replacement of support brace	Each	
6.15		Replacement of bearings	Each	
6.16		Replacement of Plastic / Rubber handle	Each	
6.17		Replacement of bearing holder	Each	
6.18		Powder Coating	Each	
6.19		Servicing of Items 6.1 – 6.18	Each	
7.1		Item 6: Twin Push Chair	Removal & Re-Installation	Each
7.2	Replacement of Base Plate		Each	
7.3	Replacement of Pipe (165 x 4,5 mm) (price per meter)		Each	
7.4	Replacement of Pipe (42.30mm) (price per meter)		Each	
7.5	Replacement of wooden seat/back(price per seat/ back )		each	
7.6	Replacement of Pipe (50mm) (price per meter)		each	
7.7	Replacement of Pipe (60mm) (price per meter)		each	
7.8	Refurbishment		each	

7.9		Stripping and Painting	each	
7.10		Replacement of 165mm end covers	each	
7.11		Replacement of pivot support plate	each	
7.12		Replacement of pivot plate	each	
7.13		Replacement of top collar	each	
7.14		Replacement of foot cross piece	each	
7.15		Replacement of stopper pipe	each	
7.16		Replacement of foot support	each	
7.17		Replacement of 60mm rubber ends	each	
7.18		Replacement of footplates	each	
7.19		Replacement of collar stiffener	each	
7.20		Replacement of seat support	each	
7.21		Wooden Seat / Back Support	each	
7.22		Fibreglass Seat / Back Support	each	
7.23		Replacement of foot brace	each	
7.24		Replacement of seat stiffener	each	
7.25		Replacement of 60mm end covers	each	
7.26		replacement of bearing housing	each	
7.27		Replacement of bearings	each	

7.28		Replacement of seat ends	each	
7.29		Replacement of M10 hex nuts	each	
7.30		Replacement of 34mm end covers	each	
7.31		Replacement of 2" Collar T	each	
7.32		Powder Coating	each	
7.33		Servicing of Items 7.1 – 7.32	Each	
8.1		Item 7: Twin pull up chair	Removal & Re-Installation	each
8.2	Replacement of Baseplate		each	
8.3	Replacement of 165mm post		each	
8.4	Replacement of Pipe (42.30mm) (price per meter)		each	
8.5	Replacement of 60mm pipe		each	
8.6	Replacement of chair holder		each	
8.7	Replacement of chair pivot		each	
8.8	Replacement of chair mount		each	
8.9	Stripping and Painting		each	
8.10	Replacement of clamping block		each	
8.11	Replacement of wooden seat/back(price per seat/back)		each	
8.12	Replacement of short shaft		each	
8.13	Replacement of top collar		each	

8.14		Replacement of collar stiffener	each	
8.15		Replacement of seat ends	each	
8.16		Replacement of seat support	each	
8.17		Replacement of seat stiffener	each	
8.18		Replacement of chair post	each	
8.19		Replacement of 165mm end cover	each	
8.20		Replacement of M10 hex nuts	each	
8.21		Replacement of 2" collar T	each	
8.22		Replacement of 60mm end cover	each	
8.23		Replacement of head support	each	
8.24		Replacement of head cross	each	
8.25		Replacement of collar head stiffener	each	
8.26		Replacement of pivot stiffener	each	
8.27		Replacement of bearings	each	
8.28		Replacement of bearing housing	each	
8.29		Replacement of 2" hinge top	each	
8.30		Replacement of rubber foot ends	each	
8.31		Powder Coating	each	
8.32		Wooden Seat / Back Support	each	

8.33		Fibreglass Seat / Back Support	each	
8.34		Servicing of Items 8.1 – 8.33	each	
9.1	Item 8: Twin Side Twister	Removal & Re-Installation	each	
9.2		Replacement of Baseplate	each	
9.3		Replacement of 165mm post	each	
9.4		Replacement of Pipe (48.50mm) (price per meter)	each	
9.5		Replacement of Pipe (60mm) (price per meter)	each	
9.6		Replacement of handle collar	each	
9.7		Replacement of hinge support plate	each	
9.8		Replacement of hinge support	each	
9.9		Stripping and Painting	each	
9.10		replacement of TS pivot shaft	each	
9.11		Replacement of 165mm end cover	each	
9.12		Replacement of collar stiffener	each	
9.13		Replacement of arm brace	each	
9.14		Replacement of foot plate	each	
9.15		Replacement of foot stiffener	each	
9.16	Replacement of bearings	each		
9.17	Replacement of bearing shaft	each		

9.18		Replacement of bearing housing	each	
9.19		Powder Coating	each	
9.20		Servicing of Items 9.1 – 9.19	each	
10.1	Item 9: Bicycle	Removal & Re-Installation	each	
10.2		Replacement of Baseplate	each	
10.3		Replacement of Pipe (48.50mm) (price per meter)	each	
10.4		Replacement of Pipe (60mm) (price per meter)	each	
10.5		Replacement of handle collar	each	
10.6		Replacement of hinge support plate	each	
10.7		Replacement of hinge support	each	
10.8		Stripping and Painting	each	
10.9		replacement of TS pivot shaft	each	
10.10		Replacement of collar stiffener	each	
10.11		Replacement of arm brace	each	
10.12		Replacement of foot plate	each	
10.13		Replacement of foot stiffener	each	
10.14		Replacement of bearings	each	
10.15		Replacement of bearing shaft	each	
10.16		Replacement of bearing housing	each	

10.17		Powder Coating	each	
10.18		Replacement of 32mm pipe (price per meter)	each	
10.19		Wooden Seat / Back Support	each	
10.20		Fibreglass Seat / Back Support	each	
10.21		Replacement of pivot bush	each	
10.22		Servicing of Items 10.1 – 10.21	each	
11.1	Item 10: Elliptical Cross Trainer	Removal & Re-Installation	each	
11.2		Replacement of Baseplate	each	
11.3		Replacement of Pipe (48.50mm) (price per meter)	each	
11.4		Replacement of Pipe (60mm) (price per meter)	each	
11.5		Replacement of handle collar	each	
11.6		Replacement of hinge support plate	each	
11.7		Replacement of hinge support	each	
11.8		Stripping and Painting	each	
11.9		replacement of TS pivot shaft	each	
11.10		Replacement of collar stiffener	each	
11.11		Replacement of arm brace	each	
11.12		Replacement of foot plate	each	
11.13		Replacement of foot stiffener	each	

11.14		Replacement of bearings	each	
11.15		Replacement of bearing shaft	each	
11.16		Replacement of bearing housing	each	
11.17		Powder Coating	each	
11.18		Replacement of 32mm pipe (price per meter)	each	
11.19		Replacement of pivot bush	each	
11.20		Replacement of footplate (price per plate)	each	
11.21		Replacement of hand base	each	
11.22		Servicing of Items 11.1 – 11.21	each	
12.1		Item 11: Rowing Machine	Removal & Re-Installation	each
12.2	Replacement of Baseplate		each	
12.3	Replacement of Pipe (48.50mm) (price per meter)		each	
12.4	Replacement of Pipe (60mm) (price per meter)		each	
12.5	Replacement of handle collar		each	
12.6	Replacement of hinge support plate		each	
12.7	Replacement of hinge support		each	
12.8	Stripping and Painting		each	
12.9	replacement of TS pivot shaft		each	
12.10	Replacement of collar stiffener		each	

12.11		Replacement of arm brace	each	
12.12		Replacement of foot plate	each	
12.13		Replacement of foot stiffener	each	
12.14		Replacement of bearings	each	
12.15		Replacement of bearing shaft	each	
12.16		Replacement of bearing housing	each	
12.17		Powder Coating	each	
12.18		Replacement of 32mm pipe (price per meter)	each	
12.19		Wooden Seat / Back Support	each	
12.20		Fibreglass Seat / Back Support	each	
12.21		Replacement of pivot bush	each	
12.22		replacement of hand base	each	
12.23		Servicing of Items 12.1 – 12.22	each	
13.1	Item 12. Monkey Frame	Removal & Re-Installation	each	
13.2		Replacement of Baseplates (price per plate)	each	
13.3		Replacement of pipe 60mm (price per meter)	each	
13.4		Replacement of 32mm pipe (price per meter)	each	
13.5		Replacement of pipe covers	each	
13.6		Refurbishment	each	

13.7		Stripping and Painting	each	
13.8		Powder Coating	each	
14.1	Item 13. Balancing Beam	Removal & Re-Installation	each	
14.2		Replacement of Base Plates (price per plate)	each	
14.3		Replacement of pipe 60mm(price per meter)	each	
14.4		Replacement of 60mm pipe covers	each	
14.5		Replacement of 52mm joiner	each	
14.6		Refurbishment	each	
14.7		Stripping and Painting	each	
14.8		Powder Coating	each	
15.1	Item 14. Sit Up Frame	Removal & Re-Installation	each	
15.2		Replacement of Base Plates (price per plate)	each	
15.3		Replacement of pipe 60mm(price per meter)	each	
15.4		Replacement of foot support	each	
15.5		Replacement of body support	each	
15.6		Replacement of foot support covers	each	
15.7		Replacement of wooden slats	each	
15.8		Refurbishment	each	
15.9		Stripping and Painting	each	

15.10		Powder Coating	each	
16.1	Item 15. 4-in-1 Machine	Removal & Re-Installation	each	
16.2		Replacement of base frame	each	
16.3		Replacement of pipe 165mm x 4,5mm	each	
16.4		Replacement of pipe 60mm	each	
16.5		Replacement of pipe 48mm	each	
16.6		Replacement of 40mmx10mm flat tubing	each	
16.7		Replacement of footplates	each	
16.8		Replacement of foot support	each	
16.9		Stripping and Painting	each	
16.10		Replacement of rubber footplates	each	
16.11		Replacement of head support	each	
16.12		Replacement of head cross	each	
16.13		Replacement of head collar stiffener	each	
16.14		Replacement of 2" collar T	each	
16.15		Replacement of collar stiffener	each	
16.16		Replacement of pivot plate	each	
16.17		Replacement of pivot support plate	each	
16.18		Replacement of twist support	each	

16.19		Replacement of rear stiffener	each	
16.20		Replacement of chair hinge plate	each	
16.21		Replacement of chair holder	each	
16.22		Replacement of chair post	each	
16.23		Replacement of chair base	each	
16.24		Replacement of seat support bracket	each	
16.25		Replacement of bearing shaft	each	
16.26		Replacement of bearings	each	
16.27		Replacement of bearing housing	each	
16.28		Replacement of 2" hinge top	each	
16.29		Replacement of seat bottom plates	each	
16.30		Replacement of 60mm top end covers	each	
16.31		Replacement of 60mm rubber ends	each	
16.32		Replacement of 165mm end covers	each	
16.33		Replacement of end washers	each	
16.34		Replacement of safety frame	each	
16.35		Replacement of safety mesh	each	
16.36		Replacement of twisting shaft	each	
16.37		Replacement of M10+M12 nuts	each	

16.38		Servicing of Items 16.1 – 16.37	each	
<b>GYM EQUIPMENT ASPHALT, BASE AND HARDENING SECTION</b>				
17	Concrete Base around Outdoor Gym Item. (Refer item 13.5 under specification)	Concrete Base	m <sup>2</sup>	
18	Tarmac Base around Outdoor Gym Item. (Refer item 13.6 under specification)	Tarmac Base	m <sup>2</sup>	
19	Expose aggregate stone surface around Outdoor Gym Item. (Refer item 13.11 under specification)	Expose aggregate stone surface	m <sup>2</sup>	
20.1	Black and all other colours(Oxide) Rubbing Matting around Outdoor Gym Item. (Refer item 13.10 under specification )	3.4.1 Rubber mating (10mm)	m <sup>2</sup>	
20.2		3.4.2 Rubber mating (20mm)	m <sup>2</sup>	
20.3		3.4.3 Rubber mating (30mm)	m <sup>2</sup>	
21	Synthetic surface around Outdoor Gym Item. Refer item 13.12 under specification)	Synthetic surface	m <sup>2</sup>	
22	E1 Curb Edging to be used around harden surface Refer item 13.6 under specification)	E1 Curb Edging	m <sup>2</sup>	
23	Clay- brick Edging to be used around harden surface Refer item 13.6 under specification)	Clay- brick Edging	m <sup>2</sup>	

**Pricing Instructions:**

- 5.1 State the rates and prices in Rand unless instructed otherwise in the Conditions of Tender.
- 5.2 Include in the rates, prices, and the tendered total of the prices (if any) all duties, taxes (except Value Added Tax (VAT), and other levies payable by the successful tenderer, such duties, taxes and levies being those applicable 14 days before the closing time stated in the General Tender Information.
- 5.3 All prices tendered must include all expenses, disbursements and costs (e.g. transport, accommodation etc.) that may be required for the execution of the tenderer's obligations in terms of the Contract, and shall cover the cost of all general risks, liabilities and obligations set forth or implied in the Contract as well as overhead charges and profit (in the event that the tender is successful). All prices tendered will be final and binding.
- 5.4 All prices shall be tendered in accordance with the units specified in this schedule.
- 5.5 Where a value is given in the Quantity column, a Rate and Price (the product of the Quantity and Rate) is

required to be inserted in the relevant columns.

- 5.6 The successful tenderer is required to perform all tasks listed against each item. The tenderer must therefore tender prices/rates on all items as per the section in the Price Schedule. **An item against which no rate is/are entered, or if anything other than a rate or a nil rate (for example, a zero, a dash or the word “included” or abbreviations thereof) is entered against an item, it will also be regarded as a nil rate having been entered against that item, i.e. that there is no charge for that item. The Tenderer may be requested to clarify nil rates, or items regarded as having nil rates; and the CCT may also perform a risk analysis with regard to the reasonableness of such rates.**
- 5.7 Provide fixed rates and prices for the duration of the contract that are not subject to adjustment except as otherwise provided for in clause 17 of the Conditions of Contract and as amplified in the Special Conditions of Contract.

INITIALS OF CCT OFFICIALS		
1	2	3

## C.5 SPECIFICATION(S)

### 6.1. GENERAL

#### 6.1.1 Introduction and Background

The City of Cape Town invites tenders for the supply, delivery, installation and repair of Outdoor Gym Equipment for various parks and facilities within the directorate community services & health in the City of Cape Town. This service will be required on an as and when required basis or when the need arises. The various areas indicated below has been divided into two (2) Regions; Region 1 and Region 2 as reflected in the table below. A map illustrating areas in a Zone is attached as Annexure 7. It is the intension of the City to award the tender per Schedule (Schedule 1,2 and 3)per Zone as indicated in the Pricing Instructions.

Region 1	Region 2
Blaauwberg, Northern, Table Bay, Tygerberg	Southern, Cape Flats, Mitchells Plain/Khayelitsha, Helderberg

This section of the tender document will discuss general specification and technical specifications for each item. General Specifications must be read in conjunction with the relevant specification for each item and also in accordance with the drawings. Tenderers shall comply with these specifications unless otherwise directed.

**All drawings are sketches only and are not to scale.**

#### 6.1.2 Scope

This specification covers the City of Cape Town's requirements for the supply, delivery, installation and repair of outdoor gym equipment.

The following is envisaged:

- 6.1.2.1 Supply of plant and equipment
- 6.1.2.2 Supply of labour and resources, welding, machining etc.
- 6.1.2.3 Fabrication of standard steelwork infrastructure:
- 6.1.2.4 Supply of various standard steel profiles
- 6.1.2.5 Corrosion protection of steelwork:
  - Hot dipped galvanising
  - Painting of steel
  - Powder coating of steel
- 6.1.2.6 Consumables and other:
  - Fasteners
  - Bearings,
  - Etc.
- 6.1.2.7 Minor civil works (installation of concrete foundations, grouting, paving)
- 6.1.2.8 Repairs to existing equipment

#### 6.1.3 Standards

Apart from the various material-specific codes references below, all equipment should comply to the requirements set out in SANS 51176 — equipment and surfacing, Parts 1-11.

#### 6.1.4 Hold Point Inspections and Quality Control

The following hold point inspection procedure should be followed. Fabrication can only move onto the next phase once the previous phase has been signed off by both the Tenderer and the CCT Representative. Where the CCT representative cannot do the holding point inspections, the onus is on the company to make use of a registered sub contractor to verify each check point on The City of Cape Town's behalf. These check points/holding points will be signed off and accompanied by a report to validate the authentication thereof. This will only be required for Schedule 1, the supply and installation of new outdoor gym equipment. Bidders to complete item 1.32 on page 32 in the pricing schedule for this service. This Quality assurance report will be per project and information will provider will be for each item of the project.

Phase	Hold point inspection and Quality Control	Responsibility
1	Preparation of steelwork, measuring and cutting at the manufacturers workshop	As per manufacturers procedures
2	Welding	As per manufacturers welding procedures
3	Preparation for coating	As per manufacturers procedures
4	<b>Hold Point Inspection 1</b>	<b>CCT Workshop fabrication inspection (QCP 1)</b>
5	Coating	As per manufacturers coating procedures
6	<b>Hold Point Inspection 2</b>	<b>CCT Coating inspection prior to delivery to site (QCP2)</b>
7	Delivery, Preparation and Installation on Site	As per manufacturers installation procedures
8	<b>Hold Point Inspection 3</b>	<b>CCT Site installation inspection and snagging (QCP 3)</b>
9	Address Snags	As per manufacturers installation procedures
10	<b>Hold Point Inspection 4</b>	<b>CCT Final inspection, handover and acceptance (QCP 4)</b>

The Quality Control Procedure (QCP) forms are available in Annexure F.13.1, and must be used for all equipment.

## 6.2 STEELWORK

It is the responsibility of the Tenderer to ensure that all equipment is safe, secure and stable once installed. The wall thicknesses and weld sizes shown below are minimum sizes and the Tender must ensure that a thicker wall or thicker weld is provided if deemed necessary. Any discrepancies in the specifications or drawings should be pointed out to the CCT representative.

### 6.2.1 Material Properties

All steelwork shall conform to the requirements of SANS 657 Part 1: 2011 and SANS 50025: 2009, unless specified otherwise.

All steelwork to have wall a minimum wall thickness of 3mm, unless otherwise shown.

#### Circular hollow sections (CHS)

Unless otherwise specified, all circular hollow sections (also referred to as pipes in this document) shall be made of hot-dip galvanized steel pipes. Steel pipes shall have a minimum yield strength and ultimate tensile strength as shown in the table below:

Outside diameter [mm]	Wall thickness [mm]	Minimum yield strength [MPa]	Ultimate tensile strength [MPa]
< 60.3	All thicknesses	200*	Not specified
60.3	< 3	200*	Not specified
60.3	≥ 3	355**	470
> 60.3	All thicknesses	355**	470

\*"commercial quality steel", sometimes referred to as mild steel

\*\*"structural steel"

#### Square / Rectangular hollow sections (RHS)

Unless otherwise specified, all square / rectangular pipework shall be made of hot-dip galvanized steel tubing. Steel tubing shall have a minimum yield strength and ultimate tensile strength as shown in the table below:

Wall thickness [mm]	Minimum yield strength [MPa]	Ultimate tensile strength [MPa]
< 3	200	Not specified
≥ 3	355	470

#### Base plates and endplates

Unless otherwise specified, all steel used for base plates and end plates shall have a minimum yield strength of 355 MPa and a minimum ultimate tensile strength of 470 MPa.

#### Other steel

Unless otherwise specified, all other steel sections not mentioned above shall have a minimum yield strength of 200 MPa.

## 6.2.2 Hot-dip galvanizing

All steelwork shall be hot dip galvanized in accordance with the requirements of SANS 121: 2011. All galvanizing shall take place after manufacturing (e.g. connections shall be welded and holes drilled prior to the steelwork being hot dip galvanized). No pre-galvanized steel shall be used

Minimum coating thicknesses shall be as per the table below (taken from SANS 121):

Article and its thickness	Local coating thickness (minimum) [μm]	Local coating mass (minimum) [g/m <sup>2</sup> ]	Mean coating thickness (minimum) [μm]	Local coating mass (minimum) [g/m <sup>2</sup> ]
Steel > 6 mm	70	505	85	610
Steel > 3 to ≤ 6 mm	55	395	70	505
Steel > 1.5 to ≤ 3 mm	45	325	55	395
Steel < 1.5 mm	35	250	45	325

Before galvanising all surfaces of the metalwork shall be thoroughly cleaned of all scale and rust by shot-blasting in accordance with SANS 10064: 2011 or by pickling and then fluxed ready for galvanizing.

The zinc coating shall be even and continuous over all surfaces, free of bare spots, dull or rough patches, blisters or other imperfections. The zinc coating shall show no signs of peeling and shall be uniform in thickness.

Sufficient venting and drainage holes should be provided on all manufactured steel to allow an even coating on the insides of members and to reduce costs. The Hot Dip Galvanizers Association of South Africa can be contacted for guidelines on the size and extent of drainage and venting holes.

Drainage and vent hole sized should preferably be 25% of the internal diameter for sections yielding a maximum cross-sectional area of 180cm<sup>2</sup>. This percentage can be dependant on the shape of the fabrication and consultation with the galvanizer is advised.

Where repairs to the galvanizing are required, the total uncoated areas for renovation shall not exceed 0,5 % of the total surface area of the component. Each uncoated area for renovation shall not exceed 10 cm<sup>2</sup>. If uncoated areas are larger, the article containing such areas shall be regalvanized, unless otherwise agreed between the purchaser and the galvanizer.

Only zinc-rich epoxies, such as Galvpatch, Zincfix, or similar approved two component zinc rich epoxy products, shall be used for repairs. The coating thickness on the renovated areas shall be a minimum of 100 μm unless the purchaser advises the galvanizer otherwise, for example, when the galvanized surface is to be over-coated and the thickness for renovated areas is to be the same as for the hot dip galvanized coating. The coating on the renovated areas shall be capable of giving sacrificial protection to the steel to which it is applied. Zinc rich sprays shall not be used.

## 6.2.3 Painting & Powder coating

### Packaging

All coating materials shall be delivered in the manufacturer's original, sealed containers of maximum 25 litre capacity, clearly marked with the following:

- 6.2.3.1 Manufacturer's name.
- 6.2.3.2 Product Brand and Reference Number.
- 6.2.3.3 Batch Number, which may incorporate the date of manufacture.
- 6.2.3.4 Date of manufacture, unless already incorporated in the batch number.
  - Abbreviated instructions for storage and use of the material, which shall include mixing ratios of components for multi-component materials, minimum temperature of application, method of application, and minimum and maximum over coating times where applicable.

All materials in a paint system shall be purchased from one paint manufacturer.

### Surface preparation

Preparation and application of organic coatings on hot-dip galvanizing shall be done in accordance with the Hot Dip Galvanizers Association Southern Africa's Code of Practice for Surface Preparation and Application of Organic Coatings.

Hot-dip galvanized surfaces to be painted shall not be passivated and shall be free from white rust and shall be cleaned with an approved water based galvanizing cleaner using non-metallic abrasive pads until a "water break free" surface is obtained. The surface shall then be thoroughly rinsed with clean potable water to remove all residues and dried immediately prior to painting. Where necessary to obtain adhesion a sweep blast of the surface shall be done after cleaning.

**Primer**

Hot-dip galvanized surfaces shall be painted with one coat of a two part suitable epoxy with a minimum dry film thickness (dft) of 75 µm.

**Stripe coats**

All edges and welds shall be provided with at least one stripe coat. This coat shall, preferably, be the same as the primer but can be the same as the intermediate coat.

**Painting**

Paints shall be applied strictly in accordance with the manufacturer's instructions by tradesmen skilled in this class of work. At least two final high gloss finish coats (each with a minimum DFT of 40 µm) shall be applied to the colour specified for each item. The primer coat and one coating of the final colour shall be applied in the workshop with the final coating being applied on site. Final coating shall be approved high gloss enamel paint, tenderer to state products and brands.

**Protection on Site**

Proper and adequate use of cover sheets and other means shall be made to protect the existing paintwork from damage and from metal dust and sparks when welding, grinding, and wire brushing on site. Similarly, effective steps shall be taken to prevent spillage or splashing or other damage to floors, walls and equipment when painting on site and any damage or mess caused shall be corrected at the Contractor's cost.

**Optional request: Powder coating**

Powder coating for various pieces of equipment can be requested by the Client from time to time.

The minimum thickness of powder coatings must be 60 µm of porous-free coating on corners and edges. On visible surfaces it must have an average coating thickness of at least 70 µm. All coat thicknesses must be measured according to ISO 2360. Powder coatings will be in one colour only as requested by the client.

**6.2.4 Welding and manufacturing****Standards**

Standards complying with good modern practice, and acceptable to the Engineer, shall be adopted. These include the following:

- BS EN 1011 - Arc welding carbon and carbon manganese steelwork.
- BS 4677 - Arc welding austenitic stainless steel pipework.
- BS 2633 - Class 1 Arc welding of steel pipework.
- BS 2971 - Class II Arc welding of steel pipework.
- BS 806 - Design and construction of ferrous piping in connection with land boilers (used for arc welding specification of all pipe flanges)
- BS EN 16630 – Safety Requirements for Outdoor Fitness Equipment

Welders shall be coded welders and experienced competent artisans approved in accordance with BS 4872. Welding procedures and welder's performance qualifications must be submitted in writing to the CCT representative and approved prior to the start of welding.

**Continuous welding and elimination of crevices**

Welding shall be continuous on all sides of any joint. All crevices, including those arising from welding on one side only, shall be eliminated. This requirement applies to the welding of all metals and, in this respect, it should be noted that welding deformation results from incorrect welding procedure rather than from continuous welding.

In special cases only, non-continuous welding might be approved in writing by the CCT representative. The resulting crevices shall be sealed with either a coal tar product which can be applied at thicknesses of up to 1 000 µm such as Carboline Bitumastic 50 or equivalent; or a two-part solvent free epoxy which can be applied at thicknesses of up to 600 µm such as Sigmaline 523 or equivalent.

**Weld appearance**

Welding shall be free of blowholes, projections, pinholes, splatter and undercuts and all welding flux shall be removed. All weld spatter and other sharp imperfections shall be removed prior to abrasive blasting. Prior to hot dip galvanizing, weld beads with a surface irregularity exceeding 3 mm or with sharp crests having a radius under 2 mm shall be ground.

### Site welding

Site welding shall be avoided as far as possible and shall only be undertaken with the approval of the CCT representative.

### Inspections

Equipment shall be inspected by the CCT representative after fabrication, but prior to hot-dip galvanizing.

### Testing

The CCT representative may at his discretion identify welds for non-destructive testing by an approved authority the cost of which will be borne by the supplier

### Weld size and type

All welds to be full penetration welds. Minimum weld sizes shall be as shown in the table below:

Base metal thickness [mm]	Minimum size of weld [mm]
$T < 6$	3
$6 < T < 12$	5
$12 < T < 20$	6

### General

Welding after hot-dip galvanizing is not acceptable.

Closed sections must never be incorporated in any fabrication. Sections should be interconnected using open mitred joints. Alternatively interconnected holes should be drilled before fabrication.

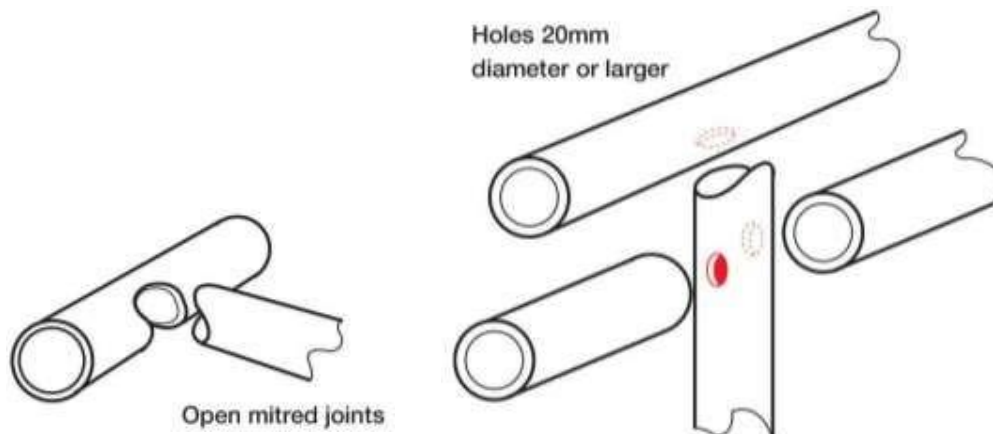

All open pipes ends shall be fully closed, either by steel capping or sealed crumpling and shall be ground smooth. Joints between all pipework shall be mitred. A slight degree of flattening the ends is allowable but should not exceed 10mm out of round when measured end on. The intent must be to ensure a profiled end on any pipe which allows a small (+ - 2mm) acceptable gap for welding when placed in position with its mating component. Multiple welds to fill gaps is not acceptable.

### 6.3 TIMBER

Any timber used shall be well seasoned, flat Meranti free from knots, cracks or splinters and shall have been treated with raw Linseed oil or equivalent. Timber used for the slide side guides shall be planed smooth.

### 6.4 FASTENERS AND ANCHOR BOLTS

#### Corrosion Protection

All anchor bolts, bolts, nuts and washers utilised in the construction of any item of equipment shall be hot dip galvanized in accordance with SANS 121: 2011.

Minimum coating thicknesses shall be as per the table below (taken from SANS 121):

Articles with threads and its thickness	Local coating thickness (minimum) [μm]	Local coating mass (minimum) [g/m <sup>2</sup> ]	Mean coating thickness (minimum) [μm]	Local coating mass (minimum) [g/m <sup>2</sup> ]
> 6 mm diameter	40	285	50	360
≤ 6 mm diameter	20	145	25	180

## Anchor Bolts

All anchor bolts shall have a minimum yield stress of 200 MPa. Only L-shaped anchor bolts shall be used. Anchor bolts shall be embedded into concrete by a minimum of 250mm, have a minimum hook length of 50mm and have a minimum diameter of 16mm, unless otherwise stated. No anchor bolts shall be welded onto steel reinforcing.



**EXAMPLE OF ANCHOR BOLT**  
SCALE 1: NTS

Only one washer shall be fitted under each anchor nut. No washers, wedges or distance pieces shall be fitted between the concrete base and steel base plate of any item. All base plate holes shall be drilled as specified on the individual play equipment plans.

While casting and curing the concrete base, anchor bolts must be held in place using a template.



**EXAMPLE OF ANCHOR BOLTS WITH TEMPLATE**  
SCALE 1: NTS

## Bolts

Where connection sare to be made on site, bolted connections shall be used as far as possible. All bolts and nuts shall be grade 8.8. **Bolts are to be welded onto endplates after tightening. All areas around the welds should be adequately cleaned and treated with a zinc rich epoxy, as specified in Section 13.2.2.**

## Base plates

Base plates may be installed directly onto the concrete foundations for all equipment, with the exception of the following, where a layer of grout is required:

Where no grout is used, the concrete surface must be smooth and level. Where

grout is required beneath the base plates, the following shall apply:

- Only non-shrink free-flowing grout shall be used;
- The grout shall have a minimum 1 day compressive strength of 30 MPa;
- Grout shall be a minimum 30mm thick;
- The edges of the grout shall be chamfered at 45°.

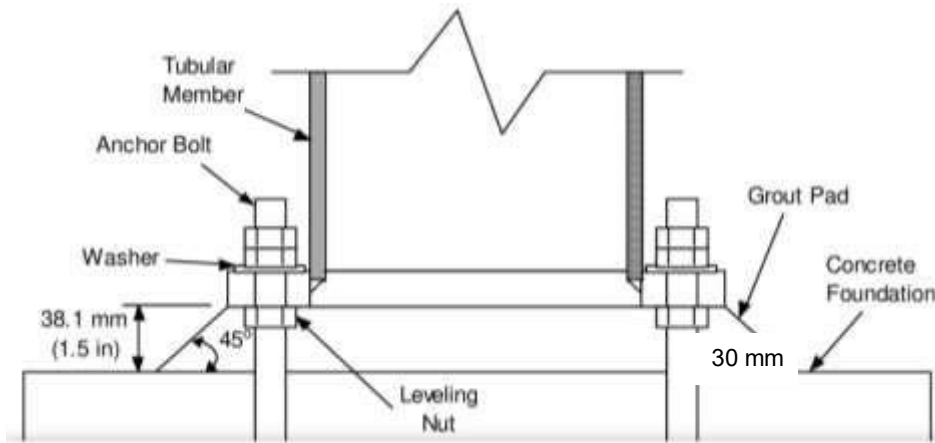

Bolt threads shall pass completely through the nut. After bolting tight, no bolt anywhere on the structure shall protrude more than two thread pitches above the nut. **Bolts are to be welded onto baseplates after tightening. All areas around the welds should be adequately cleaned and treated with a zinc rich epoxy, as specified in Section 13.2.2.**

The bolt holes in base plates should exceed the diameter of the anchor bolt by 6mm.

Holding down bolts for bearing pedestals shall each be fitted with a lock washer.

## 6.5 CONCRETE SURFACE BEDS AND FOUNDATIONS

### Excavations

Box cutting refers to excavating of bases including the labour thereof and the removal of the excavated material.

Excavate to a depth of 225mm. After removal of the soil for the concrete base, the excavated base area shall be treated with a soil sterilant to reduce the growth of weeds.

Thereafter a sub base of G5 gravel, compacted to 125mm thick, shall be laid and rolled smooth. Tenderers shall ensure that any concrete applied shall not cover the steel base plates.

A layer of 100mm thickness concrete shall be mixed and poured to create the surface (as per the mixing properties below). A Steel mesh (Ref 100, 4mm thickness) shall be inserted for additional strength.

All concrete bases shall be edged with 73mm red Clay face-brick pavers or E1 Kerbing, set in cement and level with the finished surface. Pavers are to be set 100mm concrete bed and haunched on both sides to satisfaction of Council's representative.

Tenderers shall note that any soil excavated for concrete bases shall be removed by the Tenderer unless permission is given to leave it on site.

### Material properties

All concrete foundations and surface beds shall have a minimum 28 day compressive strength of 20MPa. A concrete mixing ratio of 1:3:3 (cement:sand:stone) (by volume) can be used as a guideline. All concrete foundations shall be given a setting period of 7 days in summer and 14 days in winter before the installation of any play equipment. The size of the stone aggregate used shall be 19mm.

### Reinforcement

Concrete foundations shall be reinforced with steel reinforcing bars as per the drawings. All reinforcement shall be high tensile with a minimum yield strength of 450MPa. No reinforcement shall be welded.

Cover to reinforcing bars should be minimum 75 mm from the bottom and 50 mm from the top and sides. Plastic cover (spacing) blocks shall be used to ensure adequate cover.

### Curing

All wet cast concrete shall be cured by wetting the exposed concrete and covering with a plastic sheet for 3 days.

### General

For concrete surface bed the final surface shall be level with the surroundings and foundation blocks. The steel base plates **shall not be covered.**

## TENDER NO 2G/2026/27

All surface beds shall be edged with 73mm red Clay face-brick pavers, or e1 edging, set in cement and level with the finish concrete surface.

On surface beds with any dimension larger than 4.5 m (such as for swings) saw-cut joints must be provided at spacings of maximum 4.5 m or 30 times the slab thickness, whichever is smaller. Saw-cuts shall be ¼ the depth of the surface bed.

**The Tenderer to provide all materials required to do the work inclusive of their own water supply.**

### 6.6 ASPHALT BASES

Box cutting refers to excavating of bases including the labour thereof and the removal of the excavated material.

Where the Tenderer is required to provide a ASPHALT base he shall construct it to the size specified and to the following specifications:

Excavate to a depth of 155mm. After removal of the soil for the asphalt base, the excavated base area shall be treated with a soil sterilant to reduce the growth of weeds.

Thereafter a sub base of G5 gravel, compacted to 125mm thick, shall be laid and rolled smooth. Tenderers shall ensure that any asphalt applied shall not cover the steel base plates.

Sub base to be treated with a prime coat (Invert Bitumen emulsion).

Asphalt base of 30mm shall be hand applied and rolled, continuously graded, fine asphalt surfacing.

All asphalt bases shall be edged with 73mm red Clay face-brick pavers or E1 Kerbing, set in cement and level with the finished tarmac surface. Pavers are to be set 100mm concrete bed and haunched on both sides to satisfaction of Council's representative.

Tenderers shall note that any soil excavated for asphalt bases shall be removed by the Tenderer unless permission is given to leave it on site.

**The Tenderer to provide all materials required to do the work inclusive of their own water supply.**

### 6.7 SITE CLEARANCE

All waste material shall be removed offsite by the Tenderer and disposed of at an approved council dumpsite. This refers to any material e.g. rubble, debris, soil, plant material etc. that needs to be removed. This may also include the levelling of the site in preparation.

### 6.8 General specification:

The general specification must be read in conjunction with the relevant specification for each item as listed on the attached schedule. Tenderers shall comply with these general conditions unless otherwise directed. **All drawings are sketches and are not to scale. The responsibilities lies with the tenderer to familiarise him/herself with what have been installed previously at various City facilities and must ensure that the equipment supplied is of the same or better standard and quality. The following sites and or facilities display equipment that can be used as reference:**

- 6.8.1 Penlyn POS, Dolomite Avenue, Penlyn Estate, Athlone
- 6.8.2 Smuts Road Park, Rondebosch East
- 6.8.3 Zoo Park, Stanley Road, Kraaifontein
- 6.8.4 Tananbarus Sportfield, Tananbarus Road, off Yusuf Drive, Bo Kaap
- 6.8.5 Yeiville Sportsfield, Yoeville Road, Vredehoek
- 6.8.6 Queens Park, Queenspark Road, Woodstock
- 6.8.7 Jack Muller Park, Bellville
- 6.8.8 Nantes Park, Athlone
- 6.8.9 Green Point Park, Green Point
- 6.8.10 Tableview Beach Front, Cnr Marine Circle, Tableview

All new equipment and metal parts used for the supply and installation of new items to be powder coated (as per item 13.2.3.) after galvanizing.

Equipment must be protected with a layer UV3 or equivalent for ultraviolet protection.

Tenderers shall note that prior to painting of the finish coat, all iron and steel work, be it galvanized, or black, shall be pre-treated with Calcium Plumbate, weld able primer (NS4) or equal approved (equivalent) primer and in accordance with SABS 064/1979 (latest amended edition). At least two final high gloss finish coats (each with a DFT of 30 micron) shall be applied to the colour specified for each item. The primer coat and one coating of the final colour shall be applied in the workshop with the final coat being applied on site. Final coating shall be approved high gloss enamel paint, tenderer to state products and brand.

All open pipe ends shall be fully closed, either by steel capping or sealed crimping and shall be ground smooth. Joints between all pipework shall be mitred. A slight degree of flattening the ends is allowable but this should not exceed 10 mm out of round when measured end on. The intent must be to ensure a profiled end on any pipe which allows a small (+ - 2

mm) acceptable gap for welding when placed in position with its mating component. Multiple welds to fill gaps is not acceptable.

All seats and stepping platforms where applicable must be fabricated of 5 or more layers of **fiberglass**.

All pedals must be in a socket design to better secure the foot.

The moving pedals/parts and the main frame must be adequately spaced to avoid potential injuries.

**Equipment joints (Bearings)** must be stainless steel with cast steel rollers, must not require lubrication and must be protected against dust, sand and water.

## **6.9 INSPECTION OF WORK**

The Tenderer must contact the project manager, or his representative and give him 48 hours notification of intention to commence work on site. The Council reserves the right to inspect any item of equipment at any stage of fabrication or erection at either the Tenderer's works or at the playground concerned. For outdoor gym equipment which gets manufactured and assembled outside the borders of the City of Cape Town, the tenderer must make use of an independent service provider that is qualified to provide the City of Cape Town with a quality control procedure and report for each project. Tenderer must ensure that the information supplied is detailed. No invoices will be processed by any project manager without this information.

The Tenderer must provide a triplicate book for the manufacturing history of Council playground assets. One copy is for the supplier, one for the technical official from Council and one must be attached to the delivery note or invoice. The serial number must be reflected on all copies.

Each asset shall be marked legibly, permanently and in a position visible from the ground level with at least the following:

- **name, address and telephone number of manufacturer**
- **equipment reference and year of manufacture**

The Tenderer shall notify the project manager, or his representative – Technical Support Services once an item has been completely welded prior to hot dip galvanising and before the painting process.

All equipment must be inspected by an appointed Council Inspector prior to any finish coats being applied, If items are manufactured outside of the City of Cape Town the vendor will be responsible to provide proof of galvanising as well as picture to be supplied to ensure that process was done correctly to specification, and after final coating prior to installation. The book must be signed off by the official undertaking the inspection to the painting. Any technical concerns raised as to the quality for the work will be noted in the book. In such a case, the Tenderer must contact the official to arrange for further inspection of the particular item after completion of manufacture prior to installation. No delivery will be accepted without a certificate from the representative or technical support representative certifying that the work has been undertaken correctly.

**No payment will be made without such certificate. After installation of the play equipment, the official must sign off the equipment as acceptable. The official is entitled to contact the City's EMB Department to inspect items before installation and/or sign off of works.**

Tenderers may view the various equipment already erected at Council Sites and shall ensure that their standard of workmanship, and construction of each item conforms to it, or is better than that of the such equipment. For directions to Council sites, please contact your representative.

The Tenderer shall take precautions to safeguard from injury whilst the equipment is being erected and shall provide a night watchman/guard until such time as the equipment is safe for use, when and where needed.

Should the vendor be concerned regarding the safety of themselves or anyone with their employ at the Council site while on official duty, they need to contact the relevant regional manager.

## **6.10 SCOPE OF SERVICE FOR RUBBER AROUND GYM EQUIPMENT**

Tenderers are expected to supply, delivery and install shock absorbent, porous free draining safety matting, around outdoor exercise equipment. The extent of the surfacing is to be indicated on a plan or as agreed and pegged on site. All work done by tenderer must be to best practice methods and the implementation precautionary measures to safeguard the environment

### **6.10.1 APLICATION OF SERVICES**

The safety matting, are to be supplied and or installed in the thicknesses as indicated in the pricing schedules.

The bottom layer shall consist of an appropriately bounded low density rubber fiber layer for cushioning and an 8mm heavy duty rubber fiber protective layer on top.

The matting, must be colour impregnated using oxides or pigmentation and must be available in various colours including blue, green, yellow and black.

Any other colour requirements by the client must be discussed and agreed upon by the tenderer and client. The rubber matting must be laid as a continuous pour (not in panels or tiles) using a wet pour application with a suitable waterproof bond or connection or splice applicable where the pour of rubber matting has been stopped and start again.

Where required in hard wearing areas a single topcoat of colour impregnated Duthane (or equivalent) must be leveled or screed over the surface. Where only a 10mm thickness is required, the heavy duty, protective top layer, must be provided in the specified colour (oxide or pigmented).

#### **6.10.2 CONSTRUCTION AND EXCAVATION FOR RUBBER SURFACING**

The rubber matting, must be installed on to a suitable hard surface (i.e. concrete, tar or paving).

The tenderer must make provisions as per pricing schedule to provide a quotation to clear and level the site as well as the removal of the excavated material: Where the surface is not suitable due to excessive rubble, nature and condition of soil structure, or any obstruction being man-made or natural, this must be agreed between the tenderer and the client before rubber work commences. Only where the area or site is not suitable for normal levelling, will this apply.

Where there is no hard surface or surface available for the installation of pavers, tiles or pouring of rubber, the tenderer must provide a quotation for laying a suitable concrete or applicable surface prior to installation of the safety matting, rubber pavers or tiles.

The concrete base shall be constructed to the required size and to the following specifications to include E1 edging or paving with concrete backing and bedding where applicable. The following minimum guidelines are necessary and applicable to construct the parameters with E1 edging and or pavers to pour or lay the concrete foundation or crushed dust base for pavers.

The tenderer must do site clearing and grubbing as per pricing schedule The tenderer must set, peg and level the area

The tenderer must excavate for edging or paving or required levels, along with roadbed preparation with suitable materials identified in quotation and pricing schedule (filling for leveling sand and or stone)

The tenderer must excavate the soil or ground to a minimum of 100mm below existing natural ground level. Where concrete bases are cast above ground level and impedes the natural movement of the equipment, the tenderer must remove and recast the concrete base at their cost. Over large surfaces, expansion joints and are to be cut or placed at appropriate intervals.

The tenderer must apply an herbicide to the area to kill and curb of any weeds/vegetation and underlying seeds to germinate, this must be done by a suitable qualified and registered person holding a pest control operator certification. Other subbase required will be identified in pricing schedule.

The tenderer must lay plastic sheet layer before concrete pouring.

The tenderer to install E1 edging and pavers with concrete bedding and backing: bedding minimum 25mm \* 150mm and 106mm of minimum 45degree backing (can go to 50mm-75mm).

The tenderer to pour concert slab according to the needs identified in quotation with or without wire reinforce meshed identified. Concrete should be given the required setting or bonding or hardening period. A minimum of 48hours, a 7day period to obtain a minimum 70% hardening stage for the applicable rubber mat pouring or tile adhesive and applying the tiles. The concrete strength must be a minimum of 20MPA and shall be laid on a well compacted base.

The final surface shall be level with the surroundings or natural ground level. Any steel base plates for the play and exercise equipment shall not be covered. All concrete bases shall be edged with face brick (73 mmx 108 mm soldier course) or with E1 concrete kerning set in cement hunching (as per the diagram) and be from 10mm up to 50mm above the finished concrete surface. Where rubber matting is more than 20mm thick, the brick edging will be laid to make allowance for the required thickness of the rubber matting. In all instances the finished product must be level with the surrounding ground level. Brick edging must not protrude above the ground level.

Tenderer should construct or prepare a similar surface and framework as referred to above to install or lay rubber pavers. Crusher dust must be leveled compacted to depth and thickness required by the client. A layer of cement must be spread over the final level of compacted crusher dust as a bonding agent, it will be watered in and compacted if need be before pavers are to be laid according need. All final paved surfaces must be compacted as per standard to even out areas.

The tenderer as per pricing schedule; must provide a quotation for the removal and disposal of existing or old pavers, tiles and rubber pavers. This also including surface preparation for the new tiles, rubber pavers and rubber matting

Site clearance to be done prior and post construction phases; site rehabilitation must be done upon handing it over to the client for the operational phase. Site clearance will be done to construct the surfaces of foundations; either concrete, screed or compacted surface with edging to apply rubber matting, tiles or pavers.

The tenderer must remove all spillage and spoilage created as a direct or indirect cause or impact of its operations on site and the environment. The disposal of this must be done at approved waste disposal site. (On termination of the project and leave the site in a neat, tidy condition)

## 6.11 EXPOSED AGGREGATE CONCRETE SURFACING DESCRIPTION

This work shall consist of the construction of a SABS approved Quality Concrete surfacing with an exposed aggregate finish. All work shall be in accordance with approved Building Standard

### 6.11.1 MATERIALS

Materials shall meet minimum standards requirements and SABS approved.

PPC 42,5R or equivalent

Pre-moulded Resilient Joint Filler

Wire Fabric for Concrete Reinforcement

Water: sullied by appointed contractor.

Additional:

A. Concrete:

1. Concrete shall meet the minimum requirements for use in concrete casting works

B. Coarse Aggregate:

1. Coarse aggregate shall be Brown coloured Mix Stone of average 13mm in size. Samples must be submitted to the Project Manager for inspection and written approval prior to construction.

C. Welded Mesh Fabric: 6.0M X 2.4M X 4.0MM

D. Retarding Agent: Retarding agent shall comply with the requirements of SABS. Documentation must be submitted to the Project Manager for approval prior to construction.

### 6.11.2 CONSTRUCTION DETAILS

The general construction details for manufacturing, transporting and placing concrete shall meet the requirements of the manufacturer and the SABS. Layout and design of surface to be marked out and approved by Project Manager before any excavation can start. Excavation to be done as per agreed depth. Sub-Soil to be compacted as per minimum standards. The exposed aggregate concrete surfacing shall be constructed by a method employing a retarding agent. The concrete shall be poured in one course to the full depth shown on the plans, screeded and finished. The concrete shall not be vibrated. Curing procedures shall begin immediately upon finishing the surface. Within one hour after the concrete is placed, the retarding agent shall be sprayed on the concrete surface according to the manufacturer's recommendation. The surfacing shall be wet-cured, then the aggregate shall be exposed by washing off the cement paste using a high pressure water hose and hard bristle broom. The finished surface shall be completely covered with aggregate with a uniform appearance, to the satisfaction of the Project Manager. The aggregate exposed shall have a minimum of 20mm depth of exposure. The depth of exposure shall be measured by laying a straight edge across the plane of the surface and measuring down to the concrete matrix. The concrete surface shall be scored at intervals as indicated by the Project Manager on site. Wire fabric for concrete reinforcement shall be embedded at mid-depth in the slab, unless otherwise agreed. A pre-moulded resilient joint filler shall be installed at all joints between surfacing and curb, pavement, building, etc. Joint intervals shall be agreed on and approved by Project Manager.

### 6.11.3 METHOD OF MEASUREMENT

Exposed aggregate concrete surfacing will be measured as the number of surface square meters measured in place.

### 6.11.4 ADDITIONAL REQUIREMENTS

Contractor will be responsible to supply own water on site. All reasonable measures will be taken to prevent environmental pollution and any concrete spills will be removed immediately and area made good. Construction staff will be issued with minimum required personal protective clothing, clean drinking water and ablution facilities will be provided on site for the duration of construction. Removal, disposal of rubble and excavated materials and repair of any damages caused to existing infrastructure will be for the account of the appointed contractor

## 6.12 SYNTHETIC TURF SURFACING

### 6.12.1 SCOPE

This section covers the furnishing of materials and equipment for construction of synthetic surface around the outdoor gym equipment, ordered by the CCT Representative, or specified by the approved supplier/manufacturer. Construction of the surfacing shall be according to this section. Construction and preparation of the earthwork layers and ancillary work shall be according to, and measured under, the relevant sections of the Standard Specifications.

### 6.12.2 STANDARDS AND REFERENCES

All materials, workmanship and procedures shall comply with the relevant requirements of all current Standards, Codes of Practice and Specifications promulgated by South African National Standards (SANS). All testing shall be executed as per ASTM standards.

### 6.12.3 EXECUTION OF WORK

#### 6.12.3.1 SITE EXAMINATION

A thorough geotechnical investigation of the site soil must be undertaken before any construction or design commences. The testing of the site soils shall determine the types of soil and their variability, the soil strength, composition, water content, potential for drainage and its potential for shrinkage/swelling through drying/wetting and other characteristics.

**6.12.3.2 EARTHWORK LAYERS**

The Contractor, the CCT Representative and Synthetic Turf Subcontractor (if applicable) shall attend a joint inspection of the completed sub-base assembly for the purpose of determining the acceptability of that surface prior to installing the synthetic turf product and to confirm actual site dimensions.

The inspection shall include a check for planarity. The finished surface level shall not vary from true plane more than 10 mm in 3 m in any direction. The Contractor shall provide all required tools and materials for conducting the planarity check. The Contractor shall correct any deviations to the satisfaction of the CCT Representative and Synthetic Pitch Installer.

The Contractor shall have a registered surveyor conduct an elevation survey of the field to determine and verify that subgrade elevations and slopes are within specified tolerance.

When any or all corrective procedures have been completed, the finished sub-base surface shall be re-inspected with the same representatives present as the initial inspection.

Once the sub-base has been deemed acceptable and approved by the CCT Representative, the Contractor shall submit a written certificate indicating the acceptance of:

6.12.3.2.1 The sub-base construction finished surface as totally suitable for the application of the selected synthetic turf system, and

6.12.3.2.2 The sub-base construction as totally suitable for work to proceed with the final installation and fully warrant the surface installation for the period and conditions specified hereafter.

Commencement of the installation of the synthetic turf shall constitute acceptance of the work completed by the Contractor, acceptance of dimensions, and hence no claims for extra work based upon these conditions shall be permitted.

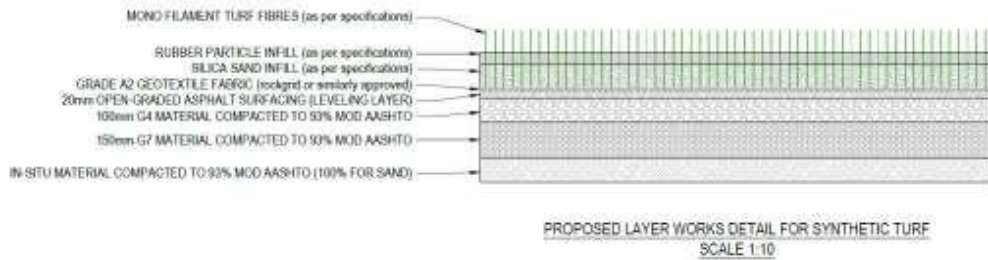

**6.12.3.3 ENVIRONMENTAL CONDITIONS**

Synthetic turf installation shall only be permitted when ambient air temperature is above 2°C and the relative humidity is below 35% or as specified by the product manufacturer. Installation shall not commence when rain is imminent.

The product shall only be installed once the prepared base is suitably free from dirt, dust, and petroleum products, is moisture free and sufficiently secured to prevent vehicular and pedestrian access.

**6.12.3.4 MAINTENANCE**

The synthetic turf installer shall provide detailed written maintenance instructions, suggested guidelines for the system. Maintenance of the systems typically consists of cleaning, stain removal, minor seam repair, dragging or redistribution of any infill material, and management of infill compaction. A primary goal of grooming maintenance is to keep the fibres standing in an upright position, which minimizes wear and UV degradation and can have a beneficial effect on performance, playing characteristics and longevity of the surface.

The equipment specified by the turf manufacturer and/or installer shall be supplied to site by the Contractor.

**6.13.1 MATERIAL**

**a) Turf:**

**i. 11 mm Yarn**

The turf fibre shall be LSR fibrillated yarn, 100% thiolon. The turf fibre shall be from a single source and the same dye lot. The pile height shall be 11 mm with a minimum 6.500/1 dtex. The backing weight shall be a minimum of 160 g/m<sup>2</sup>.

The turf fibres shall be guaranteed for a period of 8 years not to fade or fail (as distinguished from a change in texture) or have a pile height decrease of 50% of pile height as result of UV degradation.

**ii. 40 mm Yarn**

The turf fibre shall be monofilament, 100% polyethylene and non-abrasive with a minimum thickness of 300 microns. The turf fibre shall be from a single source and the same dye lot. The yarn weight shall be a minimum of 1,100 g/m<sup>2</sup>. The pile height shall be 40 mm with a minimum dtex of 14,000. The backing weight shall be a minimum of 260 g/m<sup>2</sup>.

The turf fibres shall be guaranteed for a period of 8 years not to fade or fail (as distinguished from a change in texture) or have a pile height decrease of 50% of pile height as result of UV degradation.

**iii. 50 mm Yarn**

The turf fibre shall be monofilament, 100% polyethylene and non-abrasive with a minimum thickness of 350 microns. The turf fibre shall be from a single source and the same dye lot. The yarn weight shall be a minimum of 1,400 g/m<sup>2</sup>. The pile height shall be 50 mm with a minimum dtex of 13,200.

The turf fibres shall be guaranteed for a period of 8 years not to fade or fail (as distinguished from a change in texture) or have a pile height decrease of 50% of pile height as result of UV degradation.

**b) Infill**

100% new infill shall be used.

A combination of sand and rubber shall be used and applied as per the manufacturer's specifications. Sand:

Quartz sand, colour: tan, 80% round, 0.2 — 0.8 mm in size and heavy metal safe.

Rubber infill: Styrene butadiene rubber (SBR), colour: black, 0.7 – mm in size, heavy metal safe and 99% fibre free.

**6.13.2 SUBMITTALS, TESTING AND QUALITY CONTROL**

The contractor shall engage the service of an approved independent testing laboratory for the testing of materials and the quality testing of layer works, to ensure that his work conforms to the specifications.

No separate payment will be made for such testing by an approved independent laboratory, the costs of which will be deemed to be included in the contractor's tendered rates for the various items of work requiring testing in accordance with the specifications.

The Contractor shall submit the following for approval and/or administration purposes prior to commencing with construction:

- 6.13.2.1 Product Literature: Submit two (2) copies of manufacturer's recommended installation and maintenance information, including any technical criteria for evaluation of the installed product;
- 6.13.2.2 Descriptions of all equipment recommended for the maintenance and repair of turf product, as well as a list of any activities not recommended relative to the warranty;
- 6.13.2.3 A letter and specification sheet certifying that the products to be used meet or exceed the specified requirements;
- 6.13.2.4 Certified copies of independent (third-party) laboratory reports on ASTM tests indicating material compliance with specifications;
- 6.13.2.5 The Contractor shall provide evidence that the turf system does not violate any other manufacturer's patents, patents allowed or patents pending;
- 6.13.2.6 The Contractor shall provide complete information on its warranty/insurance policy and coverage, as noted in 13.9.6;
- 6.13.2.7 Provide a complete sample copy of all warranty documentation.

**6.13.3 PERFORMANCE TESTING**

New synthetic surface shall be designed to perform to certain standards. The Contractor shall construct the synthetic surface strictly to the design of the CCT Representative.

The performance tests shall measure the following key aspects of the turf:

- 6.13.3.1 User/surface interaction;
- 6.13.3.2 Durability.

**6.13.4 FINAL ACCEPTANCE**

Prior to Final Acceptance, the Contractor shall submit to the Owner:

- Two (2) copies of Maintenance Manuals, which will include all necessary instructions for the proper care and preventative maintenance of the synthetic turf system, including painting and markings. Also address remedial measures for graffiti removal;
- Project Record Documents: Record actual locations of seams, drains or other pertinent information;

### 6.13.5 CLEANING AND COMPLETION

During construction, the Contractor shall protect all installed work from other construction activities as the installation progresses. The Contractor shall keep the area clean throughout the construction period.

Upon completion of the installation, the Contractor shall thoroughly clean all surfaces and site of all refuse resulting from the installation process. Any damage to existing fixtures or facilities resulting from the installation of the synthetic surface system shall be repaired to original condition at the Contractor's expense prior to Substantial Completion and commencement of the Warranty Period.

A snag list will be produced by the CCT Representative at the conclusion of the project. All installation project deficiencies not in dispute must be remedied by the Contractor prior to the issuance of a certificate of Substantial Completion.

6.14 When each of the items below 6.11, has been manufacture and assemble, hot dipped galvanise all items to be powder coated as indicate in 6.2.4 and concreted with anchor bolts as illustrated in 6.3 and 6.4, the exercise items shall be finished in a colour specified by the client.

### 6.15 INSTALLATION.

- 6.15.1 Item 1. Twin Walker: Concrete pedestals (concrete base) to be 600mm(L) x 900mm (W) x 600 (D)
- 6.15.2 Item 2. Double Walker: Concrete pedestals (concrete base) to be 750mm(L) x 600mm x600mm
- 6.15.3 Item 3. Twin Push-Up Frame.: Concrete pedestal (concrete base) to be 1000mm x 600mm x 600mm.
- 6.15.4 Item 4. Double Twister: Concrete pedestal (concrete base) to be 1000mm x 700mm x 600mm.
- 6.15.5 Item 5. Tai-Chi Wheel: Concrete pedestal (concrete base) to be 800mm x 800mm x 600mm.
- 6.15.6 Item 6. Twin-Push Chair: Concrete pedestal (concrete base) to be 1000mmx800mm 600mm.
- 6.15.7 Item 7. Twin – Pull – Up – Chair: Concrete pedestal (concrete base) to be 1000mm x 700mm x 800mm.
- 6.15.8 Item 8. Twin-Side-Twister.: Concrete pedestal (concrete base) to be 700mm 600mm x 600mm.
- 6.15.9 Item 9. Bicycle: Concrete pedestal (concrete base) to be 600mm x 600mm x 600mm.
- 6.15.10 Item 10. Elliptical Cross Trainer: Concrete pedestal (concrete base) to be 600mm x 600mm x 600mm.
- 6.15.11 Item 11. Rowing Machine: Concrete pedestal (concrete base) to be 600mm x 600mm x 600mm.
- 6.15.12 Item 12. Monkey Frame.: Concrete pedestals (concrete base) to be 400mm x 400mm x 400mm.
- 6.15.13 Item 13. Balancing Beam.: Concrete pedestals (concrete base) to be 400mm x 400mm x 400mm.
- 6.15.14 Item 14. Sit – Up- Frame: concrete pedestals (concrete base) to be 400mm x 400mm x 400mm.
- 6.15.15 Item 15 4– in- One Machine.: Concrete pedestal (concrete base) to be 1500mm x 1500mm x 900mm.

### 6.16 OTHER REQUIREMENTS

- 6.16.1 The appointed contractor shall adhere to Supply, delivery and repairs instructions by the Project Manager or his/her delegated official for the use of specific machines as determined by site conditions
- 6.16.2 The contractor shall ensure that suitable equipment and staff are available at all times to provide the required service.**
- 6.16.3 The contractor shall ensure that all staff is fully conversant with all aspects of the Health and Safety regulations. (also see Health and Safety Plan process flow). Adherence to Health and Safety regulations should be applied and it is advisable that a proper HIRA for each tasks listed above should be followed.
- 6.16.4 The contractor's staff shall wear distinctive protective clothing whilst on site. The contractor is responsible for behaviour and work performance of staff whilst on site.
- 6.16.5 In the contexts of Local Labour or EPWP staff used, the contractor would be responsible for all the above items mentioned under 4.1 to 4.3
- 6.16.6 The main contractors are not allowed to sub-contract any part/whole of this contract without prior approval from the City of Cape Town. If and when permission has been granted, all sub-contractors will make use of the same list of equipment and all conditions of this tender will apply to the sub-contractor.
- 6.16.7 Installation Period:**  
The Period for the supply and final installation for any installation signage project, will not exceed 21 days from date of purchase order, unless otherwise agreed upon between the Service Provider and responsible City Official.

### 6.17 HEALTH AND SAFETY SPECIFICATIONS

All work shall be carried out in accordance with the regulations of the Occupational Health and Safety Act (85 of 1993). Any liability arising out of the activities of the contract shall be the Contractor's responsibility.

**TENDER NO 2G/2026/27**

**OVERVIEW OF HAZARD IDENTIFICATION AND RISK ASSESSMENT – E1**

**Establish HIRA Team**

- Multidisciplinary in composition.
- Members should be familiar with activities / processes assessed.
- Define scope of the HIRA:
  - Baseline – conducted prior to new projects;
  - Continuous – integral part of day-to-day activities.
  - Health RA – intended for health surveillance.



**Identify Hazards**

- Utilise the following sources for hazard identification:
  - ✓ Document Reviews: (Inspection reports, Audit Reports, Incident Statistics, HIRA reports);
  - ✓ Walk-through Inspections
  - ✓ Informal Employee Interviews
- Classify into health or safety hazards.
- Consider routine and non-routine activities.
- Consider vulnerable groups (pregnant women, disabled persons, youth).

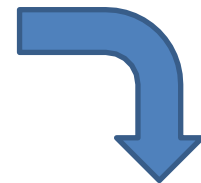
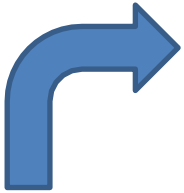

**Report, Review and Monitor Risks**

- Compile a Risk Focus Areas:  
(Dept. / Risk / Owner / Controls / Date)
- HIRA to be reviewed:
  - ✓ At least once every 2 years;
  - ✓ Changes to process, equipment;
  - ✓ New substances are considered.Monitor changes to risk rating levels
- Communicate risks to all stakeholders

**Assess and Analyse Risks**

- Determine consequences/ impact:
  - ✓ Minor / major / critical
  - ✓ Reversible / irreversible
  - ✓ Significant / Catastrophic
- Determine Exposure:
  - ✓ Continuous / Intermittent
  - ✓ Frequent / Seldom
- Determine Likelihood / Probability:
  - ✓ Likely / Unlikely
  - ✓ Rare / Possible / Almost Certain



**Treat Risks**

- Treat unacceptable risks;
- Employ hierarchy of controls:
  - ✓ Elimination – get rid of the source;
  - ✓ Substitution – introduce less hazardous alternatives;
  - ✓ Engineering controls – more effective;
  - ✓ Administrative controls – less effective;
  - ✓ PPE – generally poor

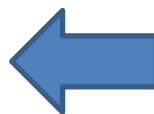

**Evaluate Risks**

- Determine Risk Rating Level  
(severity of consequence x likelihood)
- Categorise risks into:
  - ✓ Low Risk – no action
  - ✓ Moderate Risk – treat as soon as possible
  - ✓ High and Very High Risks – immediate action
- Assess effectiveness of controls

**[6.18] TRADE NAMES OR PROPRIETARY PRODUCTS**

Tenderers/Suppliers must note that wherever this document refers to any particular trade mark, name, patent, design, type, specific origin or producer, such reference shall be deemed to be accompanied by the words “or equivalent”.

**[6.19] EMPLOYMENT OF SECURITY PERSONNEL**

All security staff employed by the Supplier on behalf of the CCT or at any CCT property must be registered with Private Security Industry Regulatory Authority (PSiRA). Proof of such registration must be made available to the CCT or its agent, upon request.

**[6.20] FORMS FOR CONTRACT ADMINISTRATION**

The Supplier shall complete, sign and submit with each invoice, the following:

- a) Monthly Project Labour Report (described below)

The Monthly Project Labour Report must include details of all labour (including that of sub-contractors) that are South African citizens earning less than **[R450.00]** per day, as adjusted from time to time (excluding any benefits), who are employed on a temporary or contract basis on this contract in the month in question.

In addition to the Monthly Project Labour Report the Supplier shall simultaneously furnish the CCT’s Agent with copies of the employment contracts entered into with such labour, together with certified copies of identification documents, proof of attendance in the form of attendance register or timesheets as well as evidence of payments to such labour in the form of copies of payslips or payroll runs. If the worker is paid in cash or by cheque, this information must be recorded on the envelope and the worker must acknowledge receipt of payment by signing for it and proof of such acknowledgement shall be furnished to the CCT’s Agent.

**6.21 PLAY EQUIPMENT: DRAWINGS**

**Note that the drawing below isn’t according to scale and is a representation of what has been installed within the City of Cape Town, responsibility is with the tenderer to inspect what has been installed and ensure that the quality provided is of the same high standart/quality or better.**

Item 1: Twin Walker

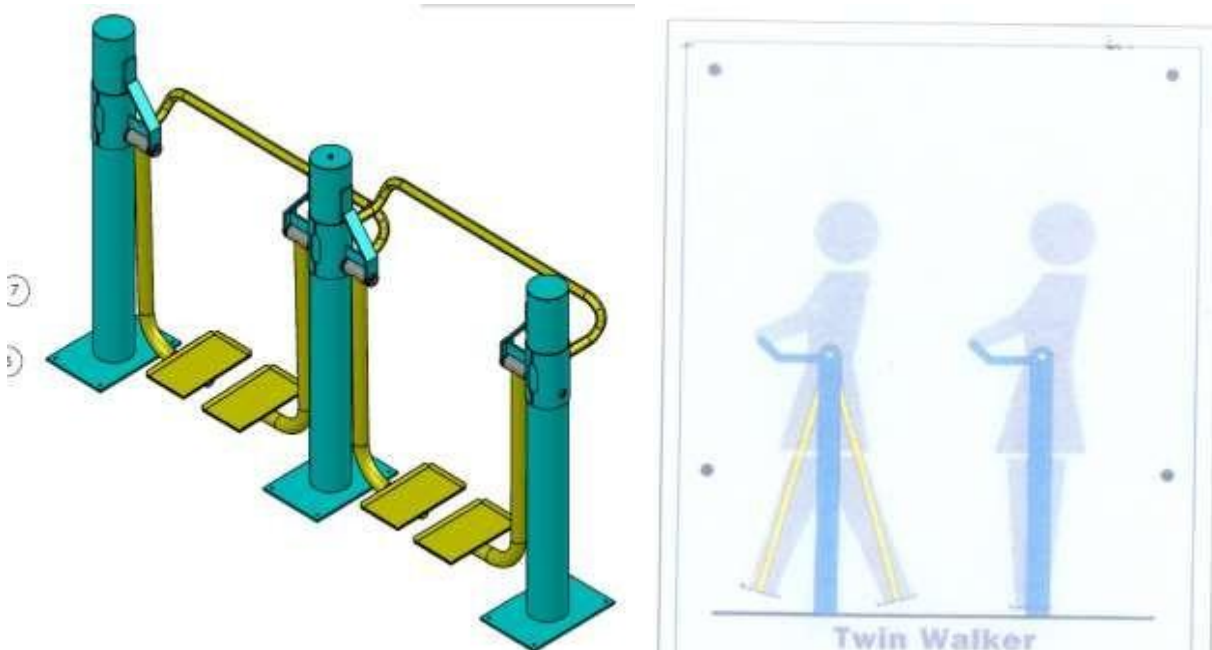

Item 2: Double Walker



Item 3: Twin Push-up frame:

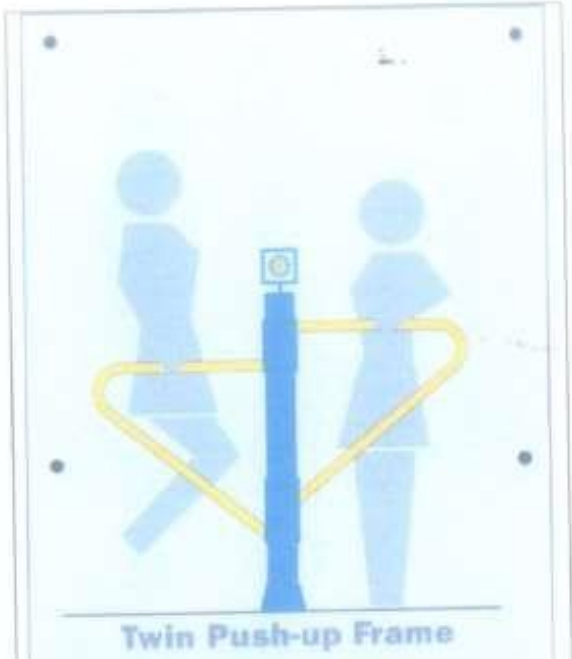
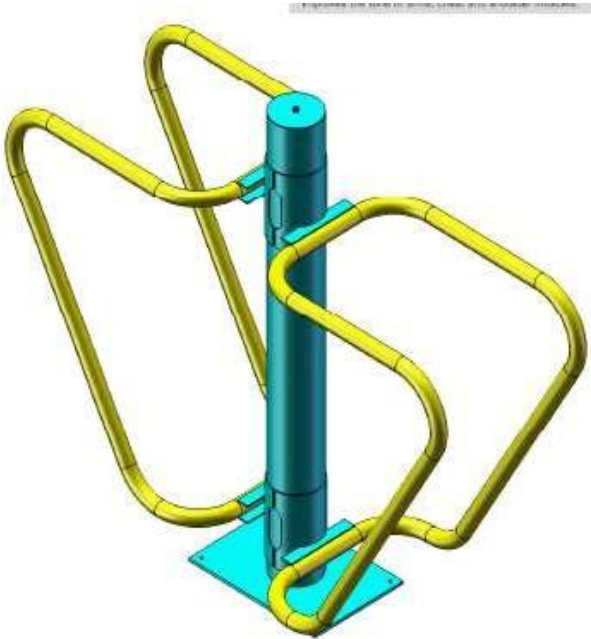

Item 4: Double twister:

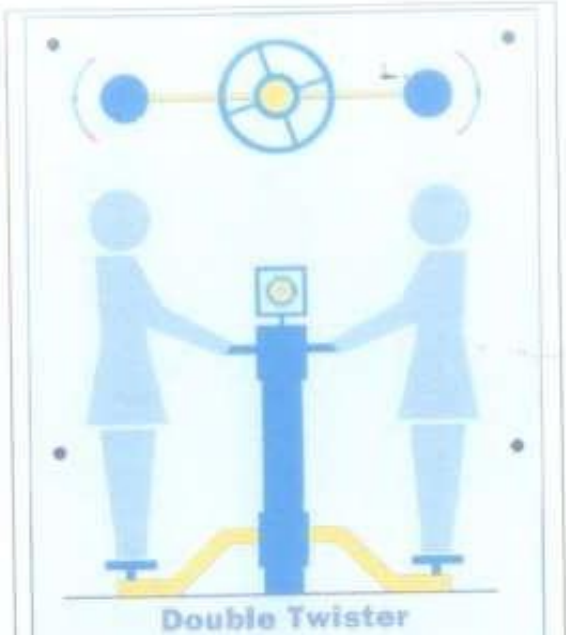

Item 5: Twin Tai – Chi wheel

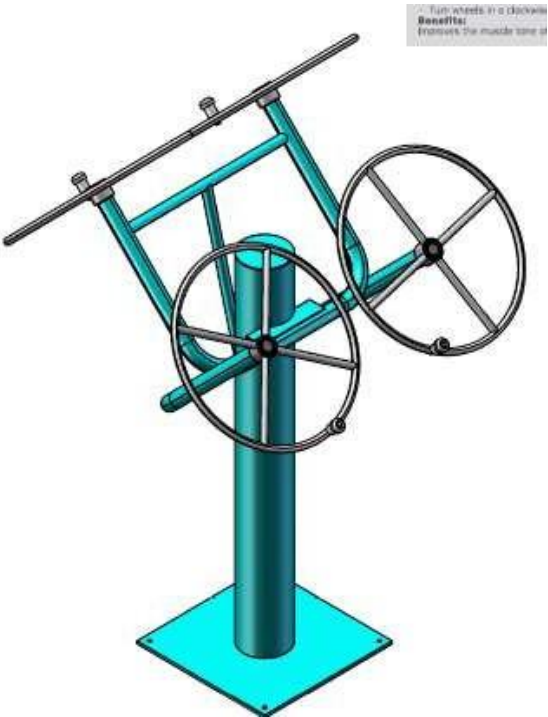

Item 6: Twin push chair

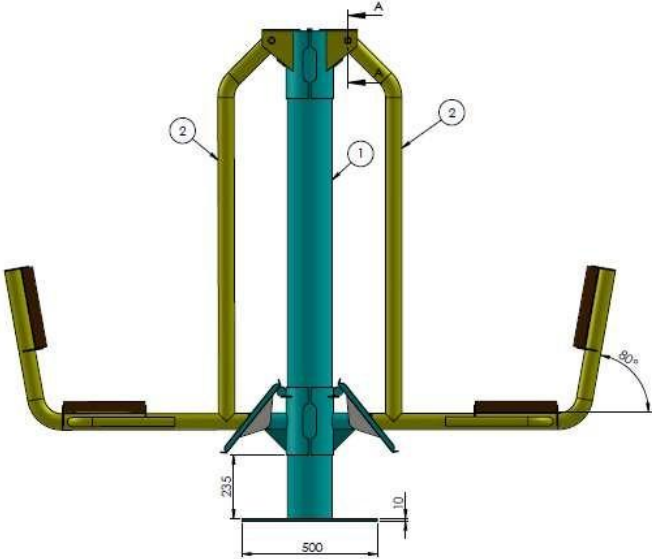

Item 7: Twin pull up chair

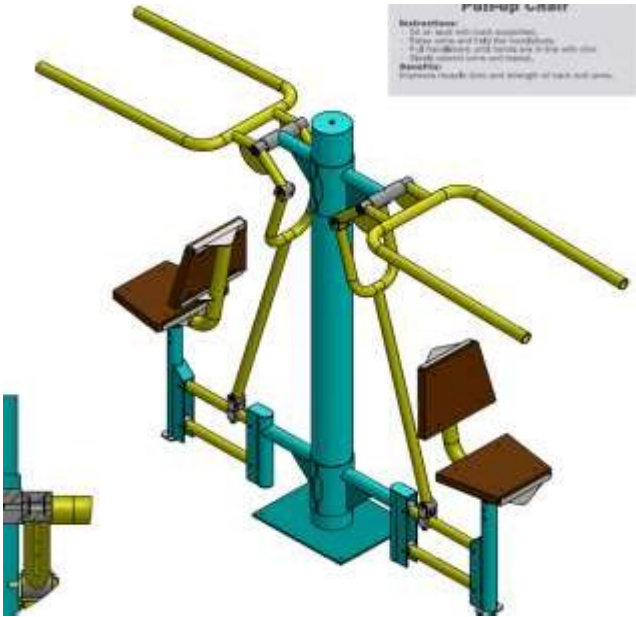

Item 8: Twin side twister

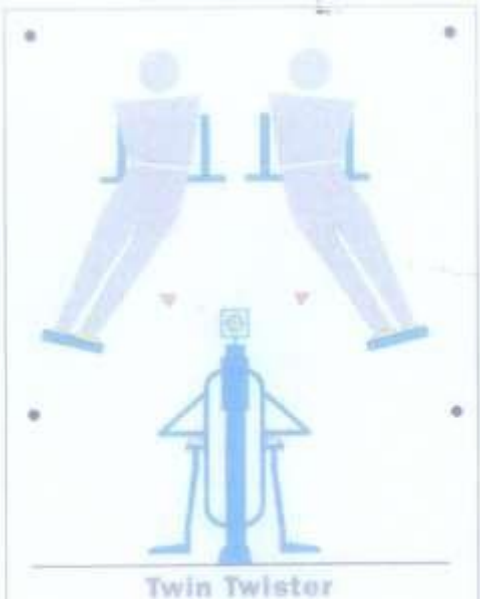
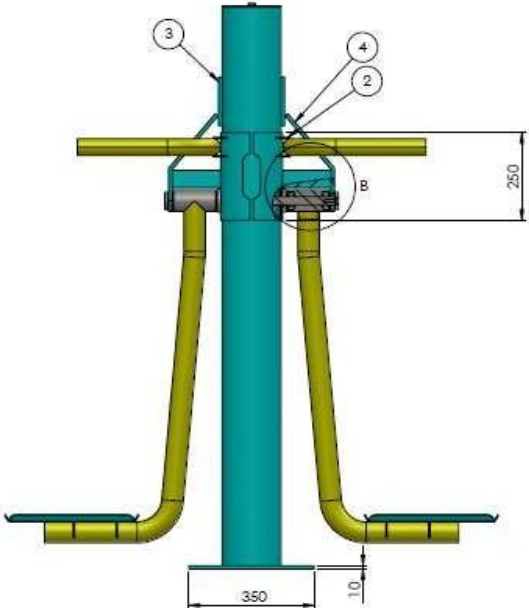

Item 9: Bicycle



Item 10: Elliptical Cross Trainer



Item 11: Rowing



Item 12: Monkey frame

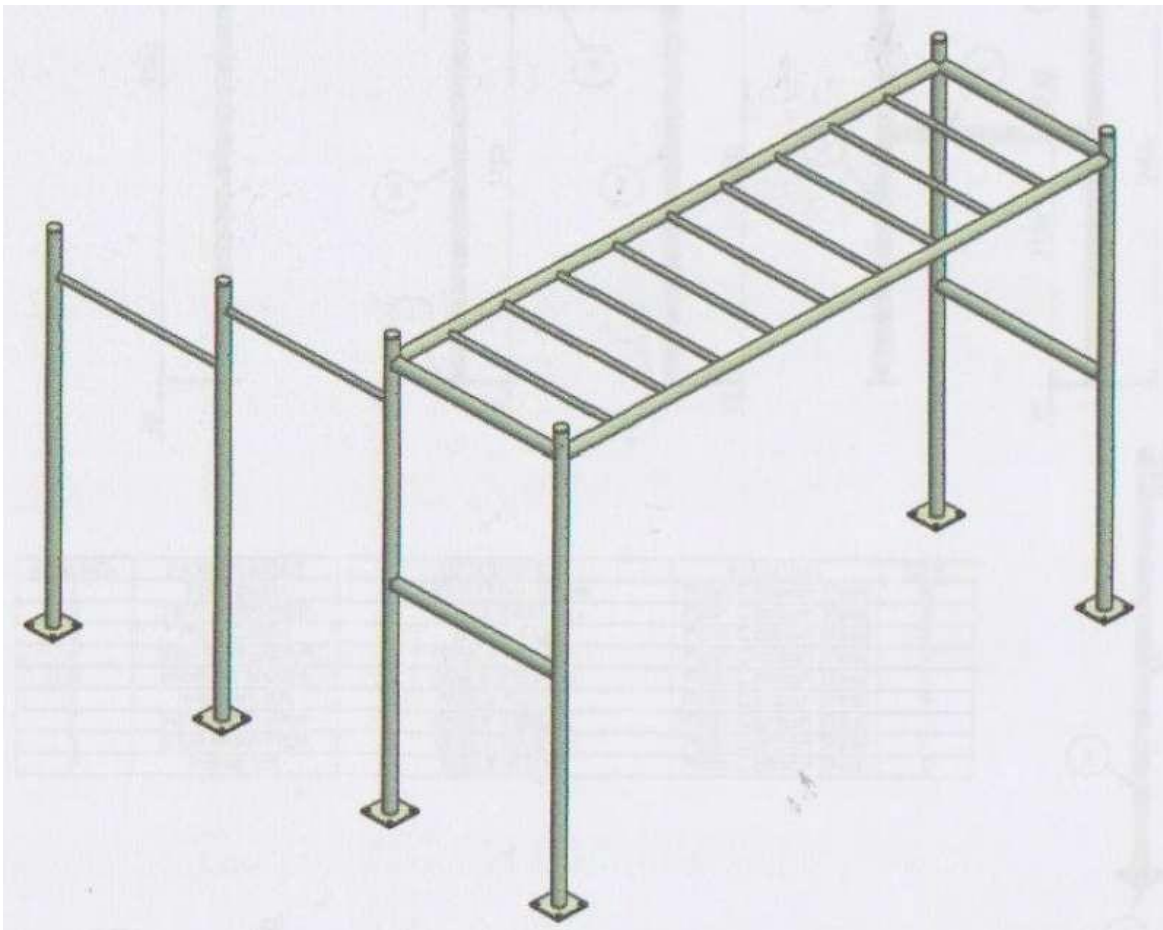

Item 13: Balancing beam



Item 14: Sit up frame



Item 15: 4 in 1 machine

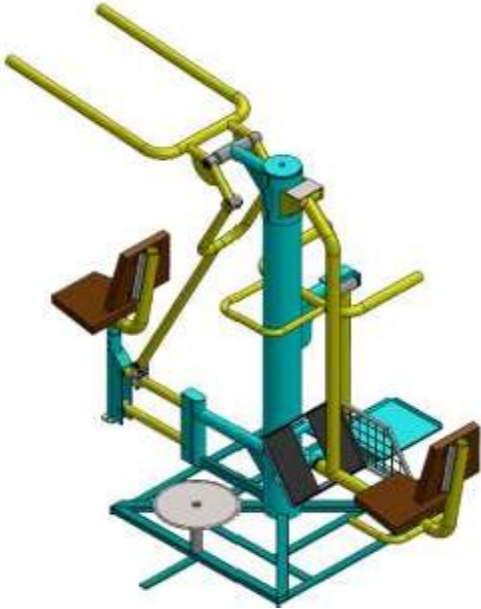

## C.6 SPECIAL CONDITIONS OF CONTRACT

The following Special Conditions of Contract, referring to the National Treasury – Conditions of Contract (revised July 2010), are applicable to this agreement.

### 1. Definitions

*Insert new clause 1.1A with the following:*

- 1.1A “Commencement Date” means the date the Supplier confirms receipt from the Purchaser of 1 (one) complete, signed copy of the Contract, the *Schedule of Deviations* (if any).
- 1.1B “Conditions of Contract” means the general conditions of contract and special conditions of contract including all other contract data incorporated by reference.

*Delete Clause 1.15 and substitute with the following*

- 1.15 The word ‘Goods’ is to be replaced everywhere it occurs in the GCC with the phrase ‘Goods and / or Services’ which means all of the equipment, machinery, materials, services, products, consumables, etc. that the Supplier is required to deliver to the Purchaser under the agreement. This definition shall also be applicable, as the context requires, anywhere where the words “supplies” and “services” occurs in the GCC.

*Delete Clause 1.19 and substitute with the following*

- 1.19 The word ‘Order’ is to be replaced everywhere it occurs in the GCC with the words ‘Purchase Order’ which means the official purchase order authorised and released on the Purchaser’s SAP System.

*Delete Clause 1.21 and substitute with the following:*

- 1.21 ‘Purchaser’ means the City of Cape Town. The address of the Purchaser is 12 Hertzog Boulevard, Cape Town, 8001 (chosen domicilium citandi et executandi).

*Add the following after Clause 1.25:*

- 1.26 ‘Supplier’ means the provider of Goods and / or Services with whom the Contract is concluded also referred to as “contractor” in the GCC.
- 1.27 "Intellectual Property" means any and all intellectual property rights of any nature anywhere in the world whether registered, registerable or otherwise, including patents, trademarks, registered designs and domain names, applications for any of the foregoing, trade or business names, copyright and rights in the nature of copyright, design rights, rights in databases, know-how, trade secrets and any other intellectual property rights which subsist in computer software, computer programs, websites, documents, information, techniques, business methods, drawings, logos, instruction manuals, lists and procedures and particulars of customers, marketing methods and procedures and advertising literature, including the "look and feel" of any websites
- 1.28 “Working Day” means Monday to Friday excluding weekends and Public Holidays (in the Republic of Sotuh Africa).

### 3. General Obligations

*Delete Clause 3.2 in its entirety and replace with the following clauses.*

- 3.2 The Parties will be liable to each other arising out of or in connection with any breach of the obligations detailed or implied in this contract, subject to clause 28.
- 3.3 If the Supplier is a joint venture, all parties in a joint venture or consortium shall be jointly and severally liable to the Purchaser in terms of the Contract and shall carry individually the minimum levels of insurance stated in the Contract, if any.

- 3.4 The Parties shall comply with all laws, regulations and bylaws of local or other authorities having jurisdiction regarding the Delivery of the Goods and/or Services and give all notices and pay all charges required by such authorities.
- 3.4.1 The Parties agree that this Contract shall also be subject to the CCT's Supply Chain Management Policy ("SCM Policy") that was applicable on the date the bid was advertised as amended from time to time. If the Purchaser adopts a new SCM Policy which contemplates that any clause therein would apply to the Contract emanating from this tender, such clause shall also be applicable to the Contract. Please refer to this document contained on the CCT's website.
- 3.4.2 Abuse of the supply chain management system is not permitted and may result in termination of the Contract, restriction of the Supplier, and/or the exercise by the CCT of any other remedies available to it as described in the SCM Policy or in law.
- 3.5 The Supplier shall:
- 3.5.1 Arrange for the documents listed below to be provided to the Purchaser prior to the issuing of the Purchase Order by the Purchaser and no later than the periods as set out in the Contract:
- a) Proof of Insurance (Refer to Clause 11) or Insurance Broker's Warrantee,
  - b) Letter of good standing from the Compensation Commissioner, or a licensed compensation insurer (Refer to Clause 11),
  - c) Initial delivery programme, and
  - d) Other requirements as detailed in the Contract.
- 3.5.2 Only when notified of the acceptance of the bid on the Date of Commencement of Contract, the Supplier shall commence with and carry out the Delivery of the Goods and/or Services in accordance with the Contract, to the satisfaction, of the Purchaser.
- 3.5.3 Provide all of the necessary materials, labour, plant and equipment required for the delivery of the Goods and/or Services including any temporary services that may be required.
- 3.5.4 Insure his workmen and employees against death or injury arising out of the delivery of the Goods.
- 3.5.5 Be continuously represented during the Delivery of the Goods and/or Services by a competent representative duly authorised to execute instructions.
- 3.5.6 In the event of a loss resulting in a claim against the insurance policies stated in clause 11, pay the first amount (excess) as required by the insurance policy.
- 3.5.7 Comply with all written instructions from the Purchaser subject to clause 18.
- 3.5.8 Complete and Deliver the goods within the period stated in clause 10, or any extensions thereof in terms of clause 21.
- 3.5.9 Make good at his own expense, all incomplete and defective Goods during the warranty period.
- 3.5.10 Pay to the Purchaser any penalty for delay as due on demand by the Purchaser. The Supplier hereby consents to such amounts being deducted from any payment due to the Supplier.
- 3.5.11 Comply with the provisions of the OHAS Act & all relevant regulations.
- 3.5.12 Comply with all laws relating to wages and conditions generally governing the employment of labour in the Cape Town area and any applicable Bargaining Council agreements.
- 3.5.13 Deliver the Goods in accordance with the Contract and with all reasonable care, diligence and skill in accordance with generally accepted professional techniques and standards.
- 3.6 The Purchaser shall:
- 3.6.1 Issue Purchaser Orders for the Goods and/or Services required under this Contract. No liability for payment will ensue for arising out of the Delivery of the Goods and/or Services, unless a Purchase Order

has been issued to the Supplier.

- 3.6.2 Make payment to the Supplier for the Goods and/or Services as set out herein.
- 3.6.3 Take possession of the Goods and /or Services upon Delivery by the Supplier.
- 3.6.4 Regularly inspect the Goods to establish that it is being delivered in compliance with the Contract.
- 3.6.5 Give any instructions and/or explanations and/or variations to the Supplier including any relevant advice to assist the Supplier to understand the Contract.
- 3.6.6 Grant or refuse any extension of time requested by the Supplier of the period stated in clause 10.
- 3.6.7 Inspect the Goods and/or Services to determine if, in the opinion of the Purchaser, it has been delivered in compliance with the Contract, alternatively in such a state that it can be properly used for the purpose for which it was intended.
- 3.6.8 Brief the Supplier and issue all documents, information, etc. in accordance with the contract.

**5. Use of contract documents and information; inspection, copyright, confidentiality, etc.**

*Add the following after clause 5.4:*

- 5.5 Copyright of all documents prepared by the Supplier in accordance with the relevant provisions of the Copyright Act (Act 98 of 1978) relating to the Contract shall be vested in the Purchaser. Where copyright is vested in the Supplier, the Purchaser shall be entitled to use the documents or copy them only for the purposes for which they are intended in regard to the agreement and need not obtain the Supplier's permission to copy it for such use. Where copyright is vested in the Purchaser, the Supplier shall not be liable in any way for the use of any of the information other than as originally intended in terms of the agreement and the Purchaser hereby indemnifies the Supplier against any claim which may be made against it by any person / entity, arising from the use of such documentation for other purposes.

The ownership of data and factual information collected by the Supplier and paid for by the Purchaser shall, after payment, vest with the Purchaser.

- 5.6 **Publicity and publication**  
The Supplier shall not release public or media statements or publish material related to the services or agreement within two (2) years of Delivery of the Goods, without the written approval of the Purchaser, which approval shall not be unreasonably withheld.
- 5.7 **Confidentiality**  
Both Parties shall keep all information obtained by them in the context of the agreement, confidential and shall not divulge it without the written approval of the other Party.
- 5.8 **Intellectual Property**
  - 5.8.1 The Supplier acknowledges that it shall not acquire any right, title or interest in or to the Intellectual Property of the Purchaser.
  - 5.8.2 The Supplier hereby assigns to the Purchaser, all Intellectual Property created, developed or otherwise brought into existence by it for the purposes of the agreement, unless the Parties expressly agree otherwise in writing.
  - 5.8.3 The Supplier shall, and warrants that it shall:
    - 5.8.3.1 Not be entitled to use the Purchaser's Intellectual Property for any purpose other than as contemplated in the agreement;
    - 5.8.3.2 not modify, add to, change or alter the Purchaser's Intellectual Property, or any information or data related thereto, nor may the Supplier produce any product as a result of, including and/or arising from any such information, data and Intellectual Property, and in the event that it does produce any such product, the product shall be, and be deemed in law to be, owned by the Purchaser;

- 5.8.3.3 Not apply for or obtain registration of any domain name, trademark or design which is similar to any Intellectual Property of the Purchser;
- 5.8.3.4 Comply with all reasonable directions or instructions given to it by the Purchaser in relation to the form and manner of use of the CCT Intellectual Property, including without limitation, any brand guidelines which the Purchaser may provide to the Supplier from time to time;
- 5.8.3.5 Ensure that its employees, directors, members and contractors comply strictly with the provisions of this Clause 5.5.8.4 above unless the Purchaser expressly agrees to the contrary, in writing and only after obtaining due internal authority for such agreement.
- 5.8.4 The Supplier represents and warrants to the Purchaser that, in providing Goods and/or Services for the duration of the agreement it will not infringe or make unauthorised use of the Intellectual Property rights of any third party and hereby indemnifies the Purchaser from any claims, liability, loss, damages, costs, and expenses arising from the infringement or unauthorised use by the Supplier of any third party's Intellectual Property rights.
- 5.8.5 Upon expiry of the contract period and in the event that the Contract is terminated, ended or is declared void, any and all of the Purchaser's Intellectual Property, and any and all information and data related thereto, shall be immediately handed over to the Purchaser by the Supplier and no copies thereof shall be retained by the Supplier unless the Purchaser expressly and in writing, after obtaining due internal authority, agrees otherwise.

*Add the following after clause 5.8:*

**5.9 Protection of Personal Information Act of 2013**

By submitting a tender to the Purchaser, (and by concluding any ensuing related agreement with the City of Cape Town, if applicable), the Tenderer thereby acknowledges and unconditionally agrees:

- 5.9.1 that the tenderer has been informed of the purpose of the collection and processing of its personal information as defined in the Protection of Personal Information Act of 2013 ("POPIA"), which, for the avoidance of doubt is for, and in relation to, the tender process and the negotiation, conclusion, performance and enforcement of the ensuing agreement, if applicable, as well as for the City of Cape Town's reporting purposes;
- 5.9.2 to the collection and processing of the tenderer's personal information by the City of Cape Town and agrees to make available to the City of Cape Town, all information reasonably required by the City of Cape Town for the above purposes;
- 5.9.3 that the personal information the City of Cape Town collects from the tenderer or about the tenderer may be further processed for other activities and/or purposes which are lawful, reasonable, relevant and not excessive in relation to the purposes set out above, for which it was originally collected;
- 5.9.4 that, the tenderer indemnifies the City of Cape Town and its officials, employees, and directors and undertakes to keep the City of Cape Town and its officials, employees, and directors indemnified in respect of any claim, loss, demands, liability, costs and expenses of whatsoever nature which may be made against the City of Cape Town (including the costs incurred in defending or contesting any such claim) in relation to the tenderer or the tenderer's employees', representatives' and/or sub-Suppliers' non-compliance with POPIA and/or the City of Cape Town's failure to obtain the tenderer's consent or to notify the tenderer of the reason for the processing of the tenderer's personal information;
- 5.9.5 to the disclosure of the tenderer's personal information by the City of Cape Town to any third party, where the City of Cape Town has a legal or contractual obligation to disclose such personal information to the third party (or a legitimate interest exists therein);
- 5.9.6 that, under POPIA, the tenderer may request to access, confirm, request the correction, destruction, or deletion of, or request a description of, personal information held by the City of Cape Town in relation to you, subject to applicable law; and

that under POPIA, subject to applicable law, the tenderer also has the right to be notified of a personal information breach and the right to object to, or restrict, the City of Cape Town's processing of its personal information.

## 5.10 **PERFORMANCE MONITORING**

5.10.1 As required by section 116(2)(b) of the Local Government: Municipal Financial Management Act 56 of 2003, the CCT shall monitor the performance of the Supplier on at least a monthly basis, and the Supplier agrees to provide the CCT with its full cooperation in this regard.

### **7. Performance Security**

Not Applicable. Tenderers must disregard the **Pro Forma Performance Security/ Guarantee** and are not required to furnish same.

### **8. Inspections, tests and analyses**

*Delete Clause 8.2 and substitute with the following:*

8.2 If it is a bid condition that Goods and/or Services to be produced or services to be rendered should at any stage during production or execution or on completion be subject to inspection, the premises of the bidder or Supplier shall be open, at all reasonable hours, for inspection by a representative of the Purchaser or an organisation acting on behalf of the Purchaser.

### **10. Delivery and documents**

*Delete clauses 10.1 and 10.2 and replace with the following:*

10.1 Delivery of the goods shall be made by the Supplier in accordance with the terms specified in the contract. The time for Delivery of the goods shall be the date as stated on the Purchase Order. In the case of agreements for Delivery of goods in terms of framework or panel agreements, Purchase Orders for the supply and delivery of goods may be raised up until the expiry of a framework or panel agreement, provided that the goods can be delivered within 30 (thirty) days of expiry of the framework or panel agreement. In this context, the "goods" does not include services and carries its ordinary meaning. All Purchase Orders other than for the supply and Delivery of goods (i.e. supply of services, professional services or constructions works), must be completed prior to the expiry of the contract period.

10.2 The Purchaser shall determine, in its sole discretion, whether the Goods and/or Services have been delivered in compliance with the Contract, alternatively in such a state that it can be properly used for the purpose for which it was intended. When the Purchaser determines that the Goods and/or Services have been satisfactorily delivered, the Purchaser must issue an appropriate certification, or written approval, to that effect. Invoicing may only occur, and must be dated, on or after the date of such written acceptance of the Goods.

### **11. Insurance**

*Add the following after clause 11.1:*

11.2 Without limiting the obligations of the Supplier in terms of this Contract, the Supplier shall effect and maintain the following additional insurances:

11.2.1 Public liability insurances, in the name of the Supplier, covering the Supplier and the Purchaser against liability for the death of or injury to any person, or loss of or damage to any property, arising out of or in the course of this Contract, in an amount not less than **[R20 million]** for any single claim;

11.2.2 Motor Vehicle Liability Insurance, in respect of all vehicles owned and / or leased by the Supplier, comprising (as a minimum) "Balance of Third Party" Risks including Passenger Liability Indemnity;

11.2.3 Registration / insurance in terms of the Compensation for Occupational Injuries and Disease Act, Act 130 of 1993. This can either take the form of a certified copy of a valid Letter of Good Standing issued by the Compensation Commissioner, or proof of insurance with a licenced compensation insurer, from either the Supplier's broker or the insurance company itself (see the Pro Forma Insurance Broker's Warranty).

[11.2.4 In the case of Contracts for delivery of professional services, Professional indemnity insurance providing cover in an amount of not less than **[R5 million]** in respect of each and every claim during the contract period.]

11.2.5 In the event of under insurance or the insurer's repudiation of any claim for whatever reason, the Purchaser will retain its right of recourse against the Supplier.

11.3 The Supplier shall be obliged to furnish the Purchaser with proof of such insurance as the Purchaser may require from time to time for the duration of this Contract. Evidence that the insurances have been effected in terms of this clause, shall be either in the form of an insurance broker's warranty worded precisely as per the pro forma version contained in the Pro forma Insurance Broker's Warranty or copies of the insurance policies.

## 15. Warranty

*Add to Clause 15.2:*

15.2 The warranty for this Contract shall remain valid for six (6) months from date of Delivery of the Goods and/or Services.

## 16. Payment

*Delete Clause 16.1 in its entirety and replace with the following:*

16.1 Payment of invoices will be made:

16.1.1 Within 30 (thirty) days of receiving the relevant invoice or statement from the Supplier, unless otherwise prescribed for certain categories of expenditure or specific contractual requirements in accordance with any other applicable policies of the Purchaser.

16.1.2 Notwithstanding anything contained above, the Purchaser shall not be liable for payment of any invoice that pre-dates the date of delivery of any Goods and/or Services.

*Delete Clause 16.2 in its entirety and replace with the following:*

16.2 The Supplier shall furnish the purchaser's Accounts Payable Department with an original tax invoice, clearly showing the amount due in respect of each and every claim for payment.

*Add the following after clause 16.4*

16.5 Notwithstanding any amount stated on the Purchase Order, the Supplier shall only be entitled to payment for Goods and/or Services actually delivered in terms of the Specification and Drawings, or any variations thereof made in accordance with clause 18. Any contingency sum included shall be for the sole use, and at the discretion, of the Purchaser.

16.6 The Purchaser will only make advanced payments to the Supplier in strict compliance with the terms and conditions as contained in the Pro forma Advanced Payment Guarantee and only once the authenticity of such guarantee has been verified by the Purchaser's Treasury Department.

## 17. Prices

*Add the following after clause 17.1*

17.2 If as a result of an award of a contract beyond the original tender validity period, the contract execution will be completed beyond a period of twelve (12) months from the expiry of the original tender validity period, then the contract may be subject to contract price adjustment for that period beyond such twelve (12) months. An appropriate contract price adjustment formula will be determined by the Purchaser delegated authority if such was not included in the bid documents.

17.3 If as a result of any extension of time granted, the contract execution will be completed beyond a period of twelve (12) months from the expiry of the original tender validity period, then contract price adjustment may apply to that period beyond such twelve (12) months. An appropriate contract price adjustment formula will be determined by the Director: Supply Chain Management if such was not included in the bid documents.

- 17.4 The prices for the goods and/or Services delivered and services performed shall be subject to contract price adjustment in terms of **Schedule F.1 Contract Price Adjustment and/or Rate of Exchange Variations** .

### **18. Contract Amendments**

*Delete the heading of clause 18 and replace with the following:*

### **18. Contract Amendments and Variations**

*Add the following to clause 18.1:*

Variations means changes to the Goods and/or Services, extension of the contract period or increases in the value of the Contract as a result of written instructions issued by the Purchaser to the Supplier. Such changes are subject to prior approval by the Purchaser's delegated authority. Should the Supplier deliver any Goods not described in a written instruction from the Purchaser, the Purchaser's liability for payment shall no arise until such time as the change has been duly approved and such approval communicated to the Purchaser.

### **20. Subcontracts**

*Add the following after clause 20.1:*

- 20.2 The Supplier shall be liable for the acts, defaults and negligence of any subcontractor, his agents or employees as fully as if they were the acts, defaults or negligence of the Supplier.
- 20.3 Any appointment of a subcontractor shall not amount to a contract between the Purchaser and the subcontractor, or a responsibility or liability on the part of the Purchaser to the subcontractor and shall not relieve the Supplier from any liability or obligation under the Contract.

### **21. Delays in the supplier's performance**

*Delete Clause 21.2 in its entirety and replace with the following:*

- 21.2 If at any time during the performance of obligations contained in the Contract the Supplier or its subcontractors should encounter conditions beyond their reasonable control which impede the timely delivery of the Goods and/or Services, the Supplier shall notify the Purchaser in writing, within 7 (seven) days of first having become aware of these conditions, of the facts of the delay, its cause(s) and its probable duration. As soon as practicable after receipt of the Supplier's notice, the Purchaser shall evaluate the situation, and may at his discretion extend the time for Delivery.

Where additional time is granted, the Purchaser shall also determine whether or not the Supplier is entitled to payment for additional costs in respect thereof. The principle to be applied in this regard is that where the Purchaser or any of its agents are responsible for the delay, reasonable costs shall be paid. In respect of delays that were beyond the reasonable control of both the Supplier and the Purchaser, additional time only (no costs) will be granted.

The Purchaser shall notify the Supplier in writing of his decision(s) in the above regard.

- 21.3 No provision in this Contract shall be deemed to prohibit the obtaining of Goods and/or Services from a national department, provincial department, or a local authority.

**22. Penalties**

**Delete clause 22.1 and replace with the following:**

- 22.1 Subject to GCC Clause 25, if the Supplier fails to deliver any or all of the Goods and/or Services within the period(s) specified in the Contract, the Purchaser shall, without prejudice to its other remedies under the Contract, deduct from amounts payable, as a penalty, a sum as stated herein for each day of the delay until actual Delivery or performance.

The penalty for this contract shall be 5% (per day per purchase order) or part thereof of the value of the overdue goods and service will be imposed.

*The contractor must make contact with the Project Manager / City Official within 72 hours from receiving the purchase order/s. At the site meeting a programme to determine the commencement of the work will be determined and agreed to. Should, after agreement of the delivery period, challenges to meet the agreed delivery period is experienced, it is incumbent on the successful tenderer, to engage the City Project Manager / City Official to sensitize CCT as to the nature of the delay. Any delay to the agreed upon delivery period, will be subject to the agreement and approval by the Project Manager / City Official. Should the work not be completed within the specified timeframe agreed to, penalties as contained in Clause 22 of the special conditions of contract and/or the City of Cape Town's approved dispute resolution process will be implemented.*

- 22.2 The Purchaser shall, without prejudice to its other remedies under the contract, deduct from amounts payable, financial penalties as contained on the Preference Schedule for breaches of the conditions upon which preference points were awarded.

**23. Termination for default**

*Delete the heading of clause 23 and replace with the following:*

**23. Termination**

*Add the following to the end of clause 23.1:*

If the Supplier fails to remedy the breach in terms of such notice.

*Add the following after clause 23.7:*

- 23.8 In addition to the grounds for termination due to default by the Supplier, the Contract may also be terminated:
- 23.8.1 Upon the death of the Supplier who was a Sole Proprietor, or a sole member of a Close Corporation, in which case the contract will terminate forthwith.
- 23.8.2 If the Parties, by mutual agreement, terminate the Contract.
- 23.8.3 If a material irregularity vitiates the procurement process leading to the conclusion of the Contract, rendering the procurement process and the conclusion of the resulting Contract unfair, inequitable, non-transparent, uncompetitive or not cost-effective the Contract may be terminated by the Purchaser (upon conclusion of applicable processes by the City Manager as described in the Purchaser's SCM Policy).
- 23.8.4 Reputational risk or harm to the Purchaser

The Purchaser, without prejudice to any other remedy for breach of contract, by written notice of default sent to the Supplier, may terminate the contract if the implementation of the contract may result in reputational risk or harm to the Purchaser as a result of (inter alia):

- a) reports of poor governance and/or unethical behaviour;
- b) association with known notorious individuals and family of notorious individuals;

- c) poor performance issues, known to the Purchaser
- d) negative social media reports;
- e) adverse assurance (e.g. due diligence) report outcomes; or
- f) circumstances where the relevant vendor has employed, or is directed by, anyone who was previously employed in the service of the state (as defined in clause 1.53), where the person is or was negatively implicated in any SCM irregularity.

By or in relation to the Supplier, the Contract may be terminated by the Purchaser after providing notice to the Supplier.

- 23.9 If the Contract is terminated in terms of clause 23.8, all obligations that were due and enforceable prior to the date of the termination, must be performed by the relevant Party.

**26. Termination for insolvency**

*Delete clause 26.1 and replace with the following:*

- 26.1 In the event of the Supplier becoming bankrupt or otherwise insolvent the Purchaser may elect to:
- 26.1.1 At any time, terminate the Contract by giving written notice to the Supplier; or
  - 26.1.2 Accept a Supplier’s proposal (via the liquidator) to render delivery utilising the appropriate contractual mechanisms or takes steps to ensure its rights are protected and any negative impact on service delivery is mitigated.
- 26.2 In the event of the Purchaser electing to cancel the Contract in accordance with clause 26.1.1 above, the Purchaser shall make payment of all verified and signed off invoices. In the event of there being any dispute in respect of any outstanding invoices such dispute shall be dealt with in accordance with the dispute resolution mechanism in the Contract.

**27. Settlement of Disputes**

*Amend clause 27.1 as follows:*

- 27.1 If any dispute or difference of any kind whatsoever, with the exception of termination in terms of clause 23 arises between the Purchaser and the Supplier in connection with or arising out of the Contract, the Parties shall make every effort to resolve such dispute or difference amicably, by mutual consultation.

*Delete Clause 27.2 in its entirety and replace with the following:*

- 27.2 Should the Parties fail to resolve any dispute by way of mutual consultation, either party shall be entitled to refer the matter for mediation before an independent and impartial person appointed by the City Manager in accordance with Regulation 50(1) of the Local Government: Municipal Finance Management Act, 56 of 2003 – Municipal Supply Chain Management Regulations (Notice 868 of 2005). Such referral shall be done by either party giving written notice to the other of its intention to commence with mediation. No mediation may be commenced unless such notice is given to the other party.

Irrespective whether the mediation resolves the dispute, the Parties shall bear their own costs concerning the mediation and share the costs of the mediator and related costs equally.

The mediator shall agree the procedures, representation and dates for the mediation process with the Parties. The mediator may meet the Parties together or individually to enable a settlement.

Where the Parties reach settlement of the dispute or any part thereof, the mediator shall record such agreement and on signing thereof by the Parties the agreement shall be final and binding.

Save for reference to any portion of any settlement or decision which has been agreed to be final and binding on the Parties, no reference shall be made by or on behalf of either party in any subsequent court proceedings, to any outcome of an amicable settlement by mutual consultation, or the fact that any particular evidence was given, or to any submission, statement or admission made in the course of amicable settlement by mutual consultation or mediation.

**28. Limitation of Liability**

*Delete clause 28.1 (b) and replace with the following:*

- (b) the aggregate liability of the Supplier to the Purchaser, whether under the Contract, in tort or otherwise, shall not exceed the sums insured in terms of clause 11 in respect of insurable events, or where no such amounts are stated, to an amount equal to twice the Contract price, provided that this limitation shall not apply to the cost of repairing or replacing defective equipment.

*Add the following after clause 28.1:*

28.2 Without detracting from, and in addition to, any of the other indemnities in this Contract, the Supplier shall be solely liable for and hereby indemnifies and holds harmless the Purchaser against all claims, charges, damages, costs, actions, liability, demands and/or proceedings and expense in connection with:

- a) personal injury or loss of life to any individual;  
b) loss of or damage to property;

arising from, out of, or in connection with the performance by the Supplier in terms of this Contract, save to the extent caused by the gross negligence or wilful misconduct of the Purchaser.

28.3 The Supplier and/or its employees, agents, concessionaires, suppliers, sub-contractors or customers shall not have any claim of any nature against the purchaser for any loss, damage, injury or death which any of them may directly or indirectly suffer, whether or not such loss, damages, injury or death is caused through negligence of the Purchaser or its agents or employees.

28.4 Notwithstanding anything to the contrary contained in this Contract, under no circumstances whatsoever, including as a result of its negligent (including grossly negligent) acts or omissions or those of its servants, agents or contractors or other persons for whom in law it may be liable, shall any party or its servants (in whose favour this constitutes a *stipulatio alteri*) be liable for any indirect, extrinsic, special, penal, punitive, exemplary or consequential loss or damage of any kind whatsoever, whether or not the loss was actually foreseen or reasonably foreseeable), sustained by the other party, its directors and/or servants, including but not limited to any loss of profits, loss of operation time, corruption or loss of information and/or loss of contracts.

28.5 Each party agrees to waive all claims against the other insofar as the aggregate of compensation which might otherwise be payable exceeds the aforesaid maximum amounts payable.

**31. Notices**

*Delete clauses 31.1 and 31.2 and replace with the following:*

31.1 Any notice, request, consent, approvals or other communications made between the Parties pursuant to the Contract shall be in writing and forwarded to the addresses specified in the Contract and may be given as set out hereunder and shall be deemed to have been received when:

- a) hand delivered – on the day delivery of delivery or the next Working Day,  
b) sent by registered mail – five (5) Working Days after mailing,  
c) sent by email or telefax – one (1) Working Day after transmission.

**32. Taxes and Duties**

*Delete the final sentence of 32.3 and replace with the following:*

. In this regard, it is the responsibility of the Tenderer to submit evidence in the form of a valid Tax Compliance Status PIN issued by SARS to the CCT at the Supplier Management Unit located within the Supplier Management / Registration Office, 2nd Floor (Concourse Level), Civic Centre, 12 Hertzog Boulevard, Cape Town (Tel 021 400 9242/3/4/5), or included with this tender.

*Add the following after clause 32.3:*

32.4 The VAT registration number of the CCT is 4500193497.

**ADDITIONAL CONDITIONS OF CONTRACT**

*Add the following Clause after Clause 34:*

**35. Reporting Obligations**

35.1 The Supplier shall complete, sign and submit with each delivery note, all the documents as required in the Specifications including Monthly Project Labour Reports (Annexure B). Any failure in this regard may result in a delay in the processing of payments.

<b>C.7 GENERAL CONDITIONS OF CONTRACT</b>
---

(National Treasury - General Conditions of Contract (revised July 2010))

**TABLE OF CLAUSES**

1. Definitions
2. Application
3. General
4. Standards
5. Use of contract documents and information; inspection
6. Patent rights
7. Performance security
8. Inspections, tests and analysis
9. Packing
10. Delivery and documents
11. Insurance
12. Transportation
13. Incidental services
14. Spare parts
15. Warranty
16. Payment
17. Prices
18. Contract amendments
19. Assignment
20. Subcontracts
21. Delays in the supplier's performance
22. Penalties
23. Termination for default
24. Dumping and countervailing duties
25. Force majeure
26. Termination for insolvency
27. Settlement of disputes
28. Limitation of liability
29. Governing language
30. Applicable law
31. Notices
32. Taxes and duties
33. National Industrial Participation Programme (NIPP)
34. Prohibition of restrictive practices

**1. Definitions**

1. The following terms shall be interpreted as indicated:

1.1 'Closing time' means the date and hour specified in the bidding documents for the receipt of bids.

1.2 'Contract' means the written agreement entered into between the purchaser and the supplier, as recorded in the contract form signed by the Parties, including all attachments and appendices thereto and all documents incorporated by reference therein.

1.3 'Contract price' means the price payable to the supplier under the contract for the full and proper performance of his or her contractual obligations.

1.4 'Corrupt practice' means the offering, giving, receiving, or soliciting of anything of value to influence the action of a public official in the procurement process or in contract execution.

1.5 'Countervailing duties' are imposed in cases in which an enterprise abroad is subsidised by its government and encouraged to market its products internationally.

- 1.6 'Country of origin' means the place where the goods were mined, grown or produced or from which the services are supplied. Goods are produced when, through manufacturing, processing or substantial and major assembly of components, a commercially recognised new product results that is substantially different in basic characteristics or in purpose or utility from its components.
- 1.7 'Day' means calendar day.
- 1.8 'Delivery' means delivery in compliance with the conditions of the contract or order.
- 1.9 'Delivery ex stock' means immediate delivery directly from stock actually on hand.
- 1.10 'Delivery into consignee's store or to his site' means delivered and unloaded in the specified store or depot or on the specified site in compliance with the conditions of the contract or order, the supplier bearing all risks and charges involved until the supplies are so delivered and a valid receipt is obtained.
- 1.11 'Dumping' occurs when a private enterprise abroad markets its goods on its own initiative in the RSA at lower prices than that of the country of origin, and which action has the potential to harm the local industries in the RSA.
- 1.12 'Force majeure' means an event beyond the control of the supplier, not involving the supplier's fault or negligence, and not foreseeable. Such events may include, but are not restricted to, acts of the purchaser in its sovereign capacity, wars or revolutions, fires, floods, epidemics, quarantine restrictions and freight embargoes.
- 1.13 'Fraudulent practice' means a misrepresentation of facts in order to influence a procurement process or the execution of a contract to the detriment of any bidder, and includes collusive practice among bidders (prior to or after bid submission) designed to establish bid prices at artificial, non-competitive levels and to deprive the bidder of the benefits of free and open competition.
- 1.14 'GCC' means the General Conditions of Contract.
- 1.15 'Goods' means all of the equipment, machinery, and/or other materials that the supplier is required to supply to the purchaser under the contract.
- 1.16 'Imported content' means that portion of the bidding price represented by the cost of components, parts or materials which have been or are still to be imported (whether by the supplier or his subcontractors) and which costs are inclusive of the costs abroad, plus freight and other direct importation costs such as landing costs, dock dues, import duty, sales duty or other similar tax or duty at the South African place of entry as well as transportation and handling charges to the factory in the Republic where the supplies covered by the bid will be manufactured.
- 1.17 'Local content' means that portion of the bidding price which is not included in the imported content, provided that local manufacture does take place.
- 1.18 'Manufacture' means the production of products in a factory using labour, materials, components and machinery, and includes other, related value-adding activities.
- 1.19 'Order' means an official written order issued for the supply of goods or works or the rendering of a service.
- 1.20 'Project site', where applicable, means the place indicated in bidding documents.
- 1.21 'Purchaser' means the organisation purchasing the goods.
- 1.22 'Republic' means the Republic of South Africa.
- 1.23 'SCC' means the Special Conditions of Contract.

1.24 'Services' means those functional services ancillary to the supply of the goods, such as transportation and any other incidental services, such as installation, commissioning, provision of technical assistance, training, catering, gardening, security, maintenance, and other such obligations of the supplier covered under the contract.

1.25 'Written' or 'in writing' means handwritten in ink or any form of electronic or mechanical writing.

## **2. Application**

2.1 These general conditions are applicable to all bids, contracts and orders, including bids for functional and professional services, sales, hiring, letting and the granting or acquiring of rights, but excluding immovable property, unless otherwise indicated in the bidding documents.

2.2 Where applicable, special conditions of contract are also laid down to cover specific supplies, services or works.

2.3 Where such special conditions of contract are in conflict with these general conditions, the special conditions shall apply.

## **3. General**

3.1 Unless otherwise indicated in the bidding documents, the purchaser shall not be liable for any expense incurred in the preparation and submission of a bid. Where applicable, a non-refundable fee for documents may be charged.

3.2 With certain exceptions, invitations to bid are only published in the Government Tender Bulletin. The Government Tender Bulletin may be obtained directly from the Government Printer, Private Bag X85, Pretoria 0001, or accessed electronically from [www.treasury.gov.za](http://www.treasury.gov.za).

## **4. Standards**

4.1 The goods supplied shall conform to the standards mentioned in the bidding documents and specifications.

## **5. Use of contract documents and information; inspection.**

5.1 The supplier shall not, without the purchaser's prior written consent, disclose the contract, or any provision thereof, or any specification, plan, drawing, pattern, sample, or information furnished by or on behalf of the purchaser in connection therewith, to any person other than a person employed by the supplier in the performance of the contract. Disclosure to any such employed person shall be made in confidence and shall extend only as far as may be necessary for the purposes of such performance.

5.2 The supplier shall not, without the purchaser's prior written consent, make use of any document or information mentioned in GCC clause 5.1, except for purposes of performing the contract.

5.3 Any document, other than the contract itself, mentioned in GCC clause 5.1 shall remain the property of the purchaser and shall be returned (all copies) to the purchaser on completion of the supplier's performance under the contract if so required by the purchaser.

5.4 The supplier shall permit the purchaser to inspect the supplier's records relating to the performance of the supplier and to have them audited by auditors appointed by the purchaser, if so required by the purchaser.

## **6. Patent rights**

6.1 The supplier shall indemnify the purchaser against all third-party claims of infringement of patent, trademark, or industrial design rights arising from the use of the goods or any part thereof by the purchaser.

## **7. Performance Security**

7.1 Within 30 (thirty) days of receipt of the notification of contract award, the successful bidder shall furnish to the purchaser the performance security of the amount specified in the SCC.

- 7.2 The proceeds of the performance security shall be payable to the purchaser as compensation for any loss resulting from the supplier's failure to complete his obligations under the contract.
- 7.3 The performance security shall be denominated in the currency of the contract or in a freely convertible currency acceptable to the purchaser, and shall be in one of the following forms:
- a) a bank guarantee or an irrevocable letter of credit issued by a reputable bank located in the purchaser's country or abroad, acceptable to the purchaser, in the form provided in the bidding documents or another form acceptable to the purchaser; or
  - b) A cashier's or certified cheque.
- 7.4 The performance security will be discharged by the purchaser and returned to the supplier not later than 30 (thirty) days following the date of completion of the supplier's performance obligations under the contract, including any warranty obligations, unless otherwise specified in the SCC.

## 8. Inspections, tests and analyses

- 8.1 All pre-bidding testing will be for the account of the bidder.
- 8.2 If it is a bid condition that supplies to be produced or services to be rendered should at any stage during production or execution or on completion be subject to inspection, the premises of the bidder or contractor shall be open, at all reasonable hours, for inspection by a representative of the Department or an organisation acting on behalf of the Department.
- 8.3 If there are no inspection requirements indicated in the bidding documents and no mention of such is made in the contract, but during the contract period it is decided that inspections shall be carried out, the purchaser shall itself make the necessary arrangements, including payment arrangements with the testing authority concerned.
- 8.4 If the inspections, tests and analyses referred to in clauses 8.2 and 8.3 show the supplies to be in accordance with the contract requirements, the cost of the inspections, tests and analyses shall be defrayed by the purchaser.
- 8.5 Where the supplies or services referred to in clauses 8.2 and 8.3 do not comply with the contract requirements, irrespective of whether such supplies or services are accepted or not, the cost in connection with these inspections, tests or analyses shall be defrayed by the supplier.
- 8.6 Supplies and services which are referred to in clauses 8.2 and 8.3 and which do not comply with the contract requirements may be rejected.
- 8.7 Any contract supplies may on or after delivery be inspected, tested or analysed and may be rejected if found not to comply with the requirements of the contract. Such rejected supplies shall be held at the cost and risk of the supplier, who shall, when called upon, remove them immediately at his own cost and forthwith substitute them with supplies which do comply with the requirements of the contract. Failing such removal, the rejected supplies shall be returned at the suppliers cost and risk. Should the supplier fail to provide the substitute supplies forthwith, the purchaser may, without giving the supplier further opportunity to substitute the rejected supplies, purchase such supplies as may be necessary at the expense of the supplier.
- 8.8 The provisions of clauses 8.4 to 8.7 shall not prejudice the right of the purchaser to cancel the contract on account of a breach of the conditions thereof, or to act in terms of Clause 23 of the GCC.

## 9. Packing

- 9.1 The supplier shall provide such packing of the goods as is required to prevent their damage or deterioration during transit to their final destination, as indicated in the contract. The packing shall be sufficient to withstand, without limitation, rough handling during transit and exposure to extreme temperatures, salt and precipitation during transit, and open storage. Packing, case size and weights shall take into consideration, where appropriate, the remoteness of the goods' final destination and the absence of heavy handling facilities at all points in transit.

9.2 The packing, marking, and documentation within and outside the packages shall comply strictly with such special requirements as shall be expressly provided for in the contract, including additional requirements, if any, specified in the SCC, and in any subsequent instructions ordered by the purchaser.

## **10. Delivery and documents**

10.1 Delivery of the goods shall be made by the supplier in accordance with the terms specified in the contract. The details of shipping and/or other documents to be furnished by the supplier are specified in the SCC.

10.2 Documents to be submitted by the supplier are specified in the SCC.

## **11. Insurance**

11.1 The goods supplied under the contract shall be fully insured, in a freely convertible currency, against loss or damage incidental to manufacture or acquisition, transportation, storage and delivery in the manner specified in the SCC.

## **12. Transportation**

12.1 Should a price other than an all-inclusive delivered price be required, this shall be specified in the SCC.

## **13. Incidental Services**

13.1 The supplier may be required to provide any or all of the following services, including additional services (if any) specified in the SCC:

- (a) performance or supervision of on-site assembly, and/or commissioning of the supplied goods;
- (b) furnishing of tools required for the assembly and/or maintenance of the supplied goods;
- (c) furnishing of a detailed operations and maintenance manual for each appropriate unit of the supplied goods;
- (d) performance or supervision or maintenance and/or repair of the supplied goods, for a period of time agreed by the Parties, provided that this service shall not relieve the supplier of any warranty obligations under this contract; and
- (e) training of the purchaser's personnel, at the supplier's plant and/or on-site, in assembly, start-up, operation, maintenance, and/or repair of the supplied goods.

13.2 Prices charged by the supplier for incidental services, if not included in the contract price for the goods, shall be agreed upon in advance by the Parties and shall not exceed the prevailing rates charged to other Parties by the supplier for similar services.

## **14. Spare parts**

14.1 As specified in the SCC, the supplier may be required to provide any or all of the following materials, notifications, and information pertaining to spare parts manufactured or distributed by the supplier:

- (a) such spare parts as the purchaser may elect to purchase from the supplier, provided that this election shall not relieve the supplier of any warranty obligations under the contract; and
- (b) in the event of termination of production of the spare parts:
  - (i) Advance notification to the purchaser of the pending termination, in sufficient time to permit the purchaser to procure needed requirements; and
  - (ii) following such termination, furnishing at no cost to the purchaser, the blueprints, drawings, and specifications of the spare parts, if requested.

## **15. Warranty**

15.1 The supplier warrants that the goods supplied under the contract are new, unused, of the most recent or current models, and that they incorporate all recent improvements in design and materials unless provided otherwise in the contract. The supplier further warrants that all goods supplied under this contract shall have no defect arising from design, materials, or workmanship (except when the design and/or material is required by the purchaser's specifications), or from any act or omission of the supplier, that may develop under normal use of the supplied goods in the conditions prevailing in the country of final destination.

15.2 This warranty shall remain valid for 12 (twelve) months after the goods, or any portion thereof, as the case may be, have been delivered to and accepted at the final destination indicated in the contract, or for 18 (eighteen) months after the date of shipment from the port or place of loading in the source country, whichever period concludes earlier, unless specified otherwise in the SCC.

15.3 The purchaser shall notify the supplier promptly, in writing, of any claims arising under this warranty.

15.4 Upon receipt of such notice, the supplier shall, within the period specified in the SCC and with all reasonable speed, repair or replace the defective goods or parts thereof, without costs to the purchaser.

15.5 If the supplier, having been notified, fails to remedy the defect(s) within the period specified in the SCC, the purchaser may proceed to take such remedial action as may be necessary, at the supplier's risk and expense and without prejudice to any other rights which the purchaser may have against the supplier under the contract.

## **16. Payment**

16.1 The method and conditions of payment to be made to the supplier under this contract shall be specified in the SCC.

16.2 The supplier shall furnish the purchaser with an invoice accompanied by a copy of the delivery note and upon fulfilment of any other obligations stipulated in the contract.

16.3 Payments shall be made promptly by the purchaser, but in no case later than 30 (thirty) days after submission of an invoice or claim by the supplier.

16.4 Payment will be made in Rand unless otherwise stipulated in the SCC.

## **17. Prices**

17.1 Prices charged by the supplier for goods delivered and services performed under the contract shall not vary from the prices tendered by the supplier in his bid, with the exception of any price adjustments authorized in the SCC or in the purchaser's request for bid validity extension, as the case may be.

## **18. Contract Amendments**

18.1 No variation in or modification of the terms of the contract shall be made except by written amendment signed by the Parties concerned.

## **19. Assignment**

19.1 The supplier shall not assign, in whole or in part, its obligations to perform under the contract, except with the purchaser's prior written consent.

## **20. Subcontracts**

20.1 The supplier shall notify the purchaser in writing of all subcontracts awarded under this contract if not already specified in the bid. Such notification, in the original bid or later, shall not relieve the supplier from any liability or obligation under the contract.

## **21. Delays in the supplier's performance**

21.1 Delivery of the goods and performance of services shall be made by the supplier in accordance with the time schedule prescribed by the purchaser in the contract.

21.2 If at any time during the performance of the contract, the supplier or its subcontractor(s) should encounter conditions impeding timely delivery of the goods and performance of services, the supplier shall promptly notify the purchaser in writing of the fact of the delay, its likely duration and its cause(s). As soon as practicable after receipt of the supplier's notice, the purchaser shall evaluate the situation and may at his or her discretion extend the supplier's time for performance, with or without the imposition of penalties, in which case the extension shall be ratified by the Parties by amendment of contract.

- 21.3 No provision in a contract shall be deemed to prohibit the obtaining of supplies or services from a national department, provincial department, or a local authority.
- 21.4 The right is reserved to procure, outside of the contract, small quantities of supplies; or to have minor essential services executed if an emergency arises, or the supplier's point of supply is not situated at or near the place where the supplies are required, or the supplier's services are not readily available.
- 21.5 Except as provided under GCC Clause 25, a delay by the supplier in the performance of its delivery obligations shall render the supplier liable to the imposition of penalties, pursuant to GCC Clause 22, unless an extension of time is agreed upon pursuant to GCC Clause 21.2 without the application of penalties.
- 21.6 Upon any delay beyond the delivery period in the case of a supplies contract, the purchaser shall, without cancelling the contract, be entitled to purchase supplies of a similar quality and up to the same quantity in substitution of the goods not supplied in conformity with the contract and to return any goods delivered later at the supplier's expense and risk, or to cancel the contract and buy such goods as may be required to complete the contract and, without prejudice to his other rights, be entitled to claim damages from the supplier.

## **22. Penalties**

- 22.1 Subject to GCC Clause 25, if the supplier fails to deliver any or all of the goods or to perform the services within the period(s) specified in the contract, the purchaser shall, without prejudice to its other remedies under the contract, deduct from the contract price, as a penalty, a sum calculated on the delivered price of the delayed goods or unperformed services, using the current prime interest rate, calculated for each day of the delay until actual delivery or performance. The purchaser may also consider termination of the contract pursuant to GCC Clause 23.

## **23. Termination for default**

- 23.1 The purchaser, without prejudice to any other remedy for breach of contract, by written notice of default sent to the supplier, may terminate this contract in whole or in part:
- (a) if the supplier fails to deliver any or all of the goods within the period(s) specified in the contract, or within any extension thereof granted by the purchaser pursuant to GCC Clause 21.2;
  - (b) if the supplier fails to perform any other obligation(s) under the contract; or
  - (c) if the supplier, in the judgment of the purchaser, has engaged in corrupt or fraudulent practices in competing for or in executing the contract.
- 23.2 In the event the purchaser terminates the contract in whole or in part, the purchaser may procure, upon such terms and in such manner as it deems appropriate, goods, works or services similar to those undelivered, and the supplier shall be liable to the purchaser for any excess costs for such similar goods, works or services. However, the supplier shall continue performance of the contract to the extent not terminated.
- 23.3 Where the purchaser terminates the contract in whole or in part, the purchaser may decide to impose a restriction penalty on the supplier by prohibiting such supplier from doing business with the public sector for a period not exceeding 10 years.
- 23.4 If a purchaser intends imposing a restriction on a supplier or any person associated with the supplier, the supplier will be allowed a time period of not more than 14 (fourteen) days to provide reasons why the envisaged restriction should not be imposed. Should the supplier fail to respond within the stipulated 14 (fourteen) days the purchaser may regard the intended penalty as not objected against and may impose it on the supplier.
- 23.5 Any restriction imposed on any person by the Accounting Officer/Authority will, at the discretion of the Accounting Officer/Authority, also be applicable to any other enterprise or any partner, manager, director or other person who wholly or partly exercises or exercised or may exercise control over the enterprise of the first-mentioned person, and with which enterprise or person the first-mentioned person is or was, in the opinion of the Accounting Officer/Authority, actively associated.

- 23.6 If a restriction is imposed, the purchaser must, within 5 (five) working days of such imposition, furnish the National Treasury with the following information:
- (i) the name and address of the supplier and/or person restricted by the purchaser;
  - (ii) the date of commencement of the restriction;
  - (iii) the period of restriction; and
  - (iv) the reasons for the restriction.

These details will be loaded in the National Treasury's central database of suppliers or persons prohibited from doing business with the public sector.

- 23.7 If a court of law convicts a person of an offence as contemplated in sections 12 or 13 of the Prevention and Combating of Corrupt Activities Act, Act 12 of 2004, the court may also rule that such person's name be endorsed on the Register for Tender Defaulters. When a person's name has been endorsed on the Register, the person will be prohibited from doing business with the public sector for a period of not less than five years and not more than 10 years. The National Treasury is empowered to determine the period of restriction, and each case will be dealt with on its own merits. According to section 32 of the Act the Register must be open to the public. The Register can be perused on the National Treasury website.

#### **24. Anti-dumping and countervailing duties and rights**

- 24.1 When, after the date of bid, provisional payments are required, or anti-dumping or countervailing duties are imposed, or the amount of a provisional payment or anti-dumping or countervailing right is increased in respect of any dumped or subsidised import, the State is not liable for any amount so required or imposed, or for the amount of any such increase. When, after the said date, such a provisional payment is no longer required or any such anti-dumping or countervailing right is abolished, or where the amount of such provisional payment or any such right is reduced, any such favourable difference shall, on demand, be paid forthwith by the contractor to the State, or the State may deduct such amounts from moneys (if any) which may otherwise be due to the contractor in regard to supplies or services which he or she delivered or rendered, or is to deliver or render in terms of the contract or any other contract or any other amount which may be due to him or her.

#### **25. Force majeure**

- 25.1 Notwithstanding the provisions of GCC Clauses 22 and 23, the supplier shall not be liable for forfeiture of its performance security, damages, or termination for default if, and to the extent that, his delay in performance or other failure to perform his obligations under the contract is the result of an event of force majeure.
- 25.2 If a force majeure situation arises, the supplier shall notify the purchaser promptly, in writing, of such condition and the cause thereof. Unless otherwise directed by the purchaser in writing, the supplier shall continue to perform its obligations under the contract as far as is reasonably practical, and shall seek all reasonable alternative means for performance not prevented by the force majeure event.

#### **26. Termination for insolvency**

- 26.1 The purchaser may at any time terminate the contract by giving written notice to the supplier if the supplier becomes bankrupt or otherwise insolvent. In this event, termination will be without compensation to the supplier, provided that such termination will not prejudice or affect any right of action or remedy which has accrued or will accrue thereafter to the purchaser.

#### **27. Settlement of Disputes**

- 27.1 If any dispute or difference of any kind whatsoever arises between the purchaser and the supplier in connection with or arising out of the contract, the Parties shall make every effort to resolve such dispute or difference amicably, by mutual consultation.
- 27.2 If, after 30 (thirty) days, the Parties have failed to resolve their dispute or difference by such mutual consultation, then either the purchaser or the supplier may give notice to the other party of his intention to commence with mediation. No mediation in respect of this matter may be commenced unless such notice is given to the other party.
- 27.3 Should it not be possible to settle a dispute by means of mediation, it may be settled in a South African court of law.

27.4 Mediation proceedings shall be conducted in accordance with the rules of procedure specified in the SCC.

27.5 Notwithstanding any reference to mediation and/or court proceedings herein,

- (a) the Parties shall continue to perform their respective obligations under the contract unless they otherwise agree; and
- (b) the purchaser shall pay the supplier any monies due to the supplier.

## **28. Limitation of Liability**

28.1 Except in cases of criminal negligence or wilful misconduct, and in the case of infringement pursuant to Clause 6:

- (a) the supplier shall not be liable to the purchaser, whether in contract, tort, or otherwise, for any indirect or consequential loss or damage, loss of use, loss of production, or loss of profits or interest costs, provided that this exclusion shall not apply to any obligation of the supplier to pay penalties and/or damages to the purchaser; and
- (b) the aggregate liability of the supplier to the purchaser, whether under the contract, in tort or otherwise, shall not exceed the total contract price, provided that this limitation shall not apply to the cost of repairing or replacing defective equipment.

## **29. Governing language**

29.1 The contract shall be written in English. All correspondence and other documents pertaining to the contract that is exchanged by the Parties shall also be written in English.

## **30. Applicable Law**

30.1 The contract shall be interpreted in accordance with South African laws, unless otherwise specified in the SCC.

## **31. Notices**

31.1 Every written acceptance of a bid shall be posted to the supplier concerned by registered or certified mail, and any other notice to him shall be posted by ordinary mail, to the address furnished in his bid or to the address notified later by him in writing; and such posting shall be deemed to be proper service of such notice.

31.2 The time mentioned in the contract documents for performing any act after such aforesaid notice has been given, shall be reckoned from the date of posting of such notice.

## **32. Taxes and Duties**

32.1 A foreign supplier shall be entirely responsible for all taxes, stamp duties, licence fees, and other such levies imposed outside the purchaser's country.

32.2 A local supplier shall be entirely responsible for all taxes, duties, licence fees, etc., incurred until delivery of the contracted goods to the purchaser.

32.3 No contract shall be concluded with any bidder whose tax matters are not in order. Prior to the award of a bid the Department must be in possession of a tax clearance certificate submitted by the bidder. This certificate must be an original issued by the South African Revenue Services.

## **33. National Industrial Participation (NIP) Programme**

33.1 The NIP Programme administered by the Department of Trade and Industry shall be applicable to all contracts that are subject to the NIP obligation.

## **34 Prohibition of Restrictive practices**

34.1 In terms of section 4 (1) (b) (iii) of the Competition Act, Act 89 of 1998, as amended, an agreement between or concerted practice by firms, or a decision by an association of firms, is prohibited if it is between Parties in a horizontal relationship and if a bidder(s) is/are or a contractor(s) was/were involved in collusive bidding (or bid rigging).

- 34.2 If a bidder(s) or contractor(s), based on reasonable grounds or evidence obtained by the purchaser, has/have engaged in the restrictive practice referred to above, the purchaser may refer the matter to the Competition Commission for investigation and possible imposition of administrative penalties as contemplated in the Competition Act, Act 89 of 1998.
- 34.3 If a bidder(s) or contractor(s) has/have been found guilty by the Competition Commission of the restrictive practice referred to above, the purchaser may, in addition and without prejudice to any other remedy provided for, invalidate the bid(s) for such item(s) offered, and/or terminate the contract in whole or part, and/or restrict the bidder(s) or contractor(s) from conducting business with the public sector for a period not exceeding 10 (ten) years and/or claim damages from the bidder(s) or contractor(s) concerned.

**C.8 ANNEXURES**

**Annexure A – Pro Forma Insurance Broker’s Warranty**



*Letterhead of supplier’s Insurance Broker*

Date \_\_\_\_\_

CCT  
City Manager  
Civic Centre  
12 Hertzog Boulevard  
Cape Town  
8000

Dear Sir

**TENDER NO.:** 2026/27

**TENDER DESCRIPTION:**

**NAME OF SUPPLIER:** \_\_\_\_\_

*I, the undersigned, do hereby confirm and warrant that all the insurances required in terms of the abovementioned contract have been issued and/or in the case of blanket/umbrella policies, have been endorsed to reflect the interests of the CCT with regard to the abovementioned contract, and that all the insurances and endorsements, etc., are all in accordance with the requirements of the contract.*

*I furthermore confirm that all premiums in the above regard have been paid.*

*Yours faithfully*

Signed: \_\_\_\_\_

For: \_\_\_\_\_ (Supplier’s Insurance Broker)

# Annexure B – Monthly Project Labour Report

## ANNEX 1

### CITY OF CAPE TOWN MONTHLY PROJECT LABOUR REPORT



#### Instructions for completing and submitting forms

##### General

- 1 The Monthly Project Labour Reports must be completed in full, using typed, proper case characters; alternatively, should a computer not be available, handwritten in black ink.
- 2 Incomplete / incorrect / illegible forms will not be accepted.
- 3 Any conditions relating to targeted labour stipulated in the Contract (in the case of contracted out services or works) shall apply to the completion and submission of these forms.
- 4 This document is available in Microsoft Excel format upon request from the City's EPWP office, tel 021 400 9406, email EPWPLR@capetown.gov.za.

##### Project Details

- 5 If a field is not applicable insert the letters: NA
- 6 Only the Project Number supplied by the Corporate EPWP Office must be inserted.  
The Project Number can be obtained from the Coordinator or Project Manager or from the e-mail address in point 4 above.
- 7 On completion of the contract or works project the anticipated end date must be updated to reflect the actual end date.

##### Beneficiary Details and Work Information

- 8 Care must be taken to ensure that beneficiary details correspond accurately with the beneficiary's ID document.

- 9 A new beneficiary is one in respect of which a new employment contract is signed in the current month. A certified ID copy must accompany this labour report on submission.
- 10 Was the beneficiary sourced from the City's job seeker database?
- 11 The contract end date as stated in the beneficiary's employment contract.
- 12 Where a beneficiary has not worked in a particular month, the beneficiary's name shall not be reflected on this form at all for the month in question.
- 13 Training will be recorded separately from normal working days and together shall not exceed the maximum of 23 days per month
- 14 Workers earning more than the maximum daily rate (currently R450 excluding any benefits) shall not be reflected on this form at all.

##### Submission of Forms

- 15 Signed hardcopy forms must be scanned and submitted to the City's project manager in electronic (.pdf) format, together with the completed form in Microsoft Excel format.
- 16 Scanned copies of all applicable supporting documentation must be submitted along with each monthly project labour report. Copies of employment contracts and ID documents are only required in respect of new beneficiaries.
- 17 If a computer is not available hardcopy forms and supporting documentation will be accepted.

#### PROJECT DETAILS

Numbers in cells below e.g (6) refer to the relevant instruction above for completing and submitting forms

CONTRACT OR WORKS PROJECT NAME: (6)		EPWP SUPPLIED PROJECT NUMBER: (6)										
DIRECTORATE:		DEPARTMENT:										
CONTRACTOR OR VENDOR NAME:		CONTRACTOR OR VENDOR E-MAIL ADDRESS:										
CONTRACTOR OR VENDOR CONTACT PERSON:		CONTRACTOR OR VENDOR TEL. NUMBER:	CELL WORK									
PROJECT LABOUR REPORT CURRENT MONTH (mark with "X")												
JAN	FEB	MAR	APR	MAY	JUN	JUL	AUG	SEP	OCT	NOV	DEC	YEAR

ACTUAL START DATE (yyyy/mm/dd)						ANTICIPATED / ACTUAL END DATE (yyyy/mm/dd) (7)					
TOTAL PROJECT EXPENDITURE / VALUE OF WORK DONE TO-DATE (INCLUDING ALL COSTS, BUT EXCLUDING VAT)											
R											

ANNEX 1 (continued)

MONTHLY PROJECT LABOUR REPORT

BENEFICIARY DETAILS AND WORK INFORMATION



<b>CONTRACT OR WORKS PROJECT NUMBER:</b>		<b>Year</b>	<b>Month</b>	<b>Sheet</b>		
				1	of	

No.	(8) First name	(8) Surname	(8) ID number	(9) New Beneficiary (Y/N)	Gender (M/F)	Disabled (Y/N)	(10) Job seeker database (Y/N)	Contract start date (DDMMYY)	(11) Contract end date (DDMMYY)	(12) No. days worked this month (excl. training)	(13) Training days	(14) Rate of pay per day (R - c)
1												
2												
3												
4												
5												
6												
7												
8												
9												
10												
11												
12												
13												
14												
15												
16												
17												
18												
19												
20												

0 0 R -

<b>Declared by Contractor or Vendor to be true and correct:</b>	<b>Name</b>		<b>Signature</b>	
	<b>Date</b>			

<b>Received by Employer's Agent / Representative:</b>	<b>Name</b>		<b>Signature</b>	
	<b>Date</b>			

## Annexure C - Pro Forma Performance Security/ Guarantee

### GUARANTEE PERFORMANCE SECURITY

#### GUARANTOR DETAILS AND DEFINITIONS

"Guarantor" means: .....

Physical address of Guarantor: .....

"Supplier" means: .....

"Contract Sum" means: The accepted tender amount (INCLUSIVE OF VAT) of R .....

Amount in words: .....

"Guaranteed Sum" means: The maximum amount of R .....

Amount in words: .....

"Contract" means: The agreement made in terms of the Form of Offer and Acceptance for tender no ...and such amendments or additions to the contract as may be agreed in writing between the Parties.

#### PERFORMANCE GUARANTEE

1. The Guarantor's liability shall be limited to the amount of the Guaranteed Sum.
2. The Guarantor's period of liability shall be from and including the date of issue of this Guarantee/Performance Security up to and including the termination of the Contract or the date of payment in full of the Guaranteed Sum, whichever occurs first.
3. The Guarantor hereby acknowledges that:
  - 3.1 any reference in this Guarantee/Performance to "Contract" is made for the purpose of convenience and shall not be construed as any intention whatsoever to create an accessory obligation or any intention whatsoever to create a suretyship;
  - 3.2 Its obligation under this Guarantee/Performance Security is restricted to the payment of money.
4. Subject to the Guarantor's maximum liability referred to in 1, the Guarantor hereby undertakes to pay the CCT the sum due and payable upon receipt of the documents identified in 4.1 to 4.2:
  - 4.1 A copy of a first written demand issued by the CCT to the Supplier stating that payment of a sum which is due and payable has not been made by the Supplier in terms of the Contract and failing such payment within seven (7) calendar days, the CCT intends to call upon the Guarantor to make payment in terms of 4.2;
  - 4.2 A first written demand issued by the CCT to the Guarantor at the Guarantor's physical address with a copy to the Supplier stating that a period of seven (7) days has elapsed since the first written demand in terms of 4.1 and the sum has still not been paid.
5. Subject to the Guarantor's maximum liability referred to in 1, the Guarantor undertakes to pay to the CCT the Guaranteed Sum or the full outstanding balance upon receipt of a first written demand from the CCT to the Guarantor at the Guarantor's physical address calling up this Guarantee / Performance Security, such demand stating that:
  - 5.1 The Contract has been terminated due to the Supplier's default and that this Guarantee/Performance Security is called up in terms of 5; or
  - 5.2 a provisional or final sequestration or liquidation court order has been granted against the

Supplier and that the Guarantee/Performance Guarantee is called up in terms of 5; and

- 5.3 The aforesaid written demand is accompanied by a copy of the notice of termination and/or the provisional/final sequestration and/or the provisional liquidation court order.
- 6. It is recorded that the aggregate amount of payments required to be made by the Guarantor in terms of 4 and 5 shall not exceed the Guarantor's maximum liability in terms of 1.
- 7. Where the Guarantor has made payment in terms of 5, the CCT shall upon the termination date of the Contract, submit an expense account to the Guarantor showing how all monies received in terms of this Guarantee/Performance Security have been expended and shall refund to the Guarantor any resulting surplus. All monies refunded to the Guarantor in terms of this Guarantee/Performance Security shall bear interest at the prime overdraft rate of the CCT's bank compounded monthly and calculated from the date payment was made by the Guarantor to the CCT until the date of refund.
- 8. Payment by the Guarantor in terms of 4 or 5 shall be made within seven (7) calendar days upon receipt of the first written demand to the Guarantor.
- 9. The CCT shall have the absolute right to arrange its affairs with the Supplier in any manner which the CCT may deem fit and the Guarantor shall not have the right to claim his release from this Guarantee /Performance Security on account of any conduct alleged to be prejudicial to the Guarantor.
- 10. The Guarantor chooses the physical address as stated above for the service of all notices for all purposes in connection herewith.
- 11. This Guarantee/Performance Security is neither negotiable nor transferable and shall expire in terms of 2, where after no claims will be considered by the Guarantor. The original of this Guarantee / Performance Security shall be returned to the Guarantor after it has expired.
- 12. This Guarantee/Performance Security, with the required demand notices in terms of 4 or 5, shall be regarded as a liquid document for the purposes of obtaining a court order.
- 13. Where this Guarantee/Performance Security is issued in the Republic of South Africa the Guarantor hereby consents in terms of Section 45 of the Magistrate's Courts Act No 32 of 1944, as amended, to the jurisdiction of the Magistrate's Court of any district having jurisdiction in terms of Section 28 of the said Act, notwithstanding that the amount of the claim may exceed the jurisdiction of the Magistrate's Court.

Signed at .....

Date .....

Guarantor's signatory (1) .....

Capacity .....

Guarantor's signatory (2) .....

Capacity .....

Witness signatory (1) .....

Witness signatory (2) .....

**Approved Financial Institution as at 13 August 2025**

**1.1 National Banks**

ABSA Bank Limited  
Firststrand Bank Limited  
Investec Bank Limited  
Nedbank Limited  
Standard Bank of South Africa Limited

**1.2 International Banks (with branches in South Africa)**

Barclays Bank PLC Citibank NA  
Credit Agricole Corporate and Investment Bank HSBC Bank PLC  
JPMorgan Chase Bank Societe Generale Standard Chartered Bank

**1.3 Insurance Companies**

American International Group Inc (AIG)  
Bryte Insurance Company Limited Coface SA  
Compass Insurance Company Limited  
Credit Guarantee Insurance Corporation of Africa Limited  
Guardrisk Insurance Company Limited  
Hollard Insurance Company Limited  
Infiniti Insurance Limited  
Lombard Insurance Company Limited  
Old Mutual Alternative Risk Transfer Insure Limited (OMART Insure)  
New National Assurance Company Limited  
PSG Konsult Ltd (previously Absa Insurance)  
Regent Insurance Company Limited  
Renasa Insurance Company Limited  
Santam Limited

## Annexure D - Pro Forma Advance Payment Guarantee

### ADVANCE PAYMENT GUARANTEE

#### GUARANTOR DETAILS AND DEFINITIONS

"Guarantor" means: .....

Physical address of guarantor: .....

"Supplier" means: .....

"Contract Sum" means: The accepted tender amount (INCLUSIVE of VAT) of R .....

Amount in words: .....

"Contract" means: The agreement made in terms of the Form of Offer and Acceptance and such amendments or additions to the Contract as may be agreed in writing between the Parties.

"Plant and materials" means: The Plant and materials in respect of which an advance payment prior to manufacture is required, which the CCT has agreed may be subject to advance payment, such Plant and materials being listed in the Schedule of Plant and materials.

"Schedule of Plant and materials" means: A list of Plant and materials which shows the value thereof to be included in the Guaranteed Advance Payment Sum.

"Guaranteed Advance Payment Sum" means: The maximum amount of R.....

Amount in words: .....

1. The Guarantor's liability shall be limited to the amount of the Guaranteed Advance Payment Sum.
2. The Guarantor's period of liability shall be from and including the date of issue of this Advance Payment Guarantee and up to and including the termination of the Contract or the date of payment in full of the Guaranteed Advance Payment Sum, whichever occurs first.
3. The Guarantor hereby acknowledges that:
  - 3.1 any reference in this Advance Payment Guarantee to the Contract is made for the purpose of convenience and shall not be construed as any intention whatsoever to create an accessory obligation or any intention whatsoever to create a suretyship;
  - 3.2 Its obligation under this Advance Payment Guarantee is restricted to the payment of money.
4. Subject to the Guarantor's maximum liability referred to in 1, the Guarantor hereby undertakes to pay the CCT the sum advanced to the Supplier upon receipt of the documents identified in 4.1 to 4.2:
  - 4.1 A copy of a first written demand issued by the CCT to the Supplier stating that payment of a sum advanced by the CCT has not been repaid by the Supplier in terms of the Contract ("default") and failing such payment within seven (7) calendar days, the CCT intends to call upon the Guarantor to make payment in terms of 4.2;
  - 4.2 A first written demand issued by the CCT to the Guarantor at the Guarantor's physical address with a copy to the Supplier stating that a period of seven (7) calendar days has elapsed since the first written demand in terms of 4.1 and the sum advanced has still not been repaid by the Supplier.
5. Subject to the Guarantor's maximum liability referred to in 1, the Guarantor undertakes to pay to the CCT the Guaranteed Advance Payment Sum or the full outstanding balance not repaid upon receipt of a first written demand from the CCT to the Guarantor at the Guarantor's physical address calling up this Advance Payment Guarantee, such demand stating that:

- 5.1 *the Contract has been terminated due to the Supplier's default and that this Advance Payment Guarantee is called up in terms of 5; or*
- 5.2 *a provisional or final sequestration or liquidation court order has been granted against the Supplier and that the Advance Payment Guarantee is called up in terms of 5; and*
- 5.3 *The aforesaid written demand is accompanied by a copy of the notice of termination and/or the provisional/final sequestration and/or the provisional liquidation court order.*
- 6. *It is recorded that the aggregate amount of payments required to be made by the Guarantor in terms of 4 and 5 shall not exceed the Guarantor's maximum liability in terms of 1.*
- 7. *Payment by the Guarantor in terms of 4 or 5 shall be made within seven (7) calendar days upon receipt of the first written demand to the Guarantor.*
- 9. *The CCT shall have the absolute right to arrange its affairs with the Supplier in any manner which the CCT may deem fit and the Guarantor shall not have the right to claim his release from this Advance Payment Guarantee on account of any conduct alleged to be prejudicial to the Guarantor.*
- 10. *The Guarantor chooses the physical address as stated above for the service of all notices for all purposes in connection herewith.*
- 11. *This Advance Payment Guarantee is neither negotiable nor transferable and shall expire in terms of 2, where after no claims will be considered by the Guarantor. The original of this Guarantee shall be returned to the Guarantor after it has expired.*
- 12. *This Advance Payment Guarantee, with the required demand notices in terms of 4 or 5, shall be regarded as a liquid document for the purposes of obtaining a court order.*
- 13. *Where this Guarantee/Performance Security is issued in the Republic of South Africa the Guarantor hereby consents in terms of Section 45 of the Magistrate's Courts Act No 32 of 1944, as amended, to the jurisdiction of the Magistrate's Court of any district having jurisdiction in terms of Section 28 of the said Act, notwithstanding that the amount of the claim may exceed the jurisdiction of the Magistrate's Court.*

Signed at .....

Date .....

Guarantor's signatory (1) .....

Capacity .....

Guarantor's signatory (2) .....

Capacity .....

Witness signatory (1) .....

Witness signatory (2) .....

**Approved Financial Institution as at 13 August 2025**

**1.1 National Banks**

ABSA Bank Limited  
Firststrand Bank Limited  
Investec Bank Limited  
Nedbank Limited  
Standard Bank of South Africa Limited

**1.2 International Banks (with branches in South Africa)**

Barclays Bank PLC Citibank NA  
Credit Agricole Corporate and Investment Bank HSBC Bank PLC  
JPMorgan Chase Bank Societe Generale Standard Chartered Bank

**1.3 Insurance Companies**

American International Group Inc (AIG)  
Bryte Insurance Company Limited Coface SA  
Compass Insurance Company Limited  
Credit Guarantee Insurance Corporation of Africa Limited  
Guardrisk Insurance Company Limited  
Hollard Insurance Company Limited  
Infiniti Insurance Limited  
Lombard Insurance Company Limited  
Old Mutual Alternative Risk Transfer Insure Limited (OMART Insure)  
New National Assurance Company Limited  
PSG Konsult Ltd (previously Absa Insurance)  
Regent Insurance Company Limited  
Renasas Insurance Company Limited  
Santam Limited

## Annexure F - Tender Returnable Documents

### Schedule F.1: Contract Price Adjustment and/or Rate of Exchange Variation

**1. TENDER CONDITIONS**

1. The Contract Price Adjustment (CPA) mechanism and/or provisions relating to Rate of Exchange (RoE) Variation, contained in this schedule is compulsory and binding on all Tenderers/Suppliers and this schedule (the parts relevant to the particular tender) must be completed by all Tenderers / Suppliers.
2. Tenderers/Suppliers are not permitted to amend, vary, alter or delete this schedule or any part thereof unless otherwise stated in this schedule.
3. Tenderers are not permitted to offer fixed and firm prices except as provided for in the Price Schedule.

**2. CPA PROVISIONS SELECTION**

1. The prices stipulated on the Price Schedule are subject to adjustment as set out below.
2. Tenderer to indicate the specific CPA and/or RoE provisions applicable to their bid by marking the relevant checkboxes below. Tenderers to note that the CPA and/or RoE provisions are not exclusive and multiple CPA Types can exist if the bid contains both local and foreign exchange based pricing. In such cases the CPA and/or ROE provision applies only to that particular portion of the tendered price.
3. The CPA and/or RoE provisions applicable to this tender and resulting contract are to be indicated below by checking the relevant boxes (with multiple selections only where indicated permissible):

**Indicate option CPA Type**



**Period**

**Refer to Section**

A	N/A	FIRM PRICES as per Pricing Schedule	Annual	<i>Pricing Schedule C.4 and Schedule F.1 (A)</i>
---	-----	-------------------------------------	--------	--

**LOCAL (RSA) TENDER CONTENT:**

**EITHER**

B	N/A	SEIFSA Index based CPA	Monthly / Quarterly	<i>Schedule F.1 (B)</i>
---	-----	------------------------	---------------------	-------------------------

**OR**

C	N/A	Pricelist / Quotation Based CPA	Ad-Hoc	<i>Schedule F.1 (C)</i>
---	-----	---------------------------------	--------	-------------------------

**OR**

D		STATS SA CPI Index Based CPA	Annually	<i>Schedule F.1 (D)</i>
---	--	------------------------------	----------	-------------------------

**OR/AND**

E	N/A	Sectorial Determination 1: Contract Cleaning Sector	Annually	<i>Schedule F.1 (E)</i>
---	-----	---	----------	-------------------------

**OR**

E	N/A	Sectorial Determination 6: Private Security Sector	Annually	<i>Schedule F.1 (E)</i>
---	-----	--	----------	-------------------------

**IMPORTED GOODS AND / OR COMPONENTS (IF APPLICABLE**

F	N/A	ROE based CPA	Ad-Hoc	<i>Schedule F.1 (F)</i>
---	-----	---------------	--------	-------------------------

**AND (IF REQUIRED), EITHER**

G		Pricelist / Quotation based CPA	Ad-Hoc / Periodic	/ Schedule F.1 (G)
<b>OR</b>				
H	N/A	Overseas CPI / PPI index based CPA	Ad-Hoc / Periodic	/ Schedule F.1 (H)

2.4 CPA and/or RoE provisions marked as **not applicable** is not relevant and will not apply to this tender and resulting contract.

### 3. CONTRACT CPA APPLICATIONS AND ADMINISTRATION

3.1 Any claim for variation in the contract price (either CPA or RoE adjustments) must be submitted in writing:

- i. By letter to: Director Chantal Michaels, Community Services and Health, Recreation and Parks, Nabeel Bassadien, City of Cape Town,  
P O Box 655, Cape Town, 8000 or
- ii. By email to: **RecreationandParks@capetown.gov.za**

**at least 14 days prior** to the month upon which the adjustment would become effective in the case of prices being set in advance, and as soon as relevant indices are available and no later than 60 days after the date of delivery of goods or the completion of the project (i.e. date of issue of the Taking-Over Certificate, if applicable) in the case of adjustments being claimed retrospectively for Goods or Services. The latter case is only applicable where specifically provided for in the CPA provisions.

2. When submitting a request for CPA and/or RoE adjustment the Supplier shall indicate the Rand Value claimed for each item listed on C.4 - Price Schedule, clearly indicating the item number as per C.4 - Price Schedule. Percentage increases will not be considered. A mere notification of a request for CPA without stating the new price claimed for each item shall, for the purpose of this clause, not be regarded as a valid request.
3. The CCT reserves the right to request the Supplier to submit auditor's certificates or such other documentary proof as it may require in order to verify a claim for CPA or RoE adjustments. Price adjustments will not be processed until such time as the Supplier submits such auditor's certificates or other documentary proof to the CCT. Should the Supplier fail to submit the auditor's certificates or other documentary proof to the CCT within 30 days from the written request, it shall be presumed that the Supplier has abandoned his request.
4. The CCT reserves the right to withhold payment of any claim for adjustment while only provisional figures are available and until such time as the final (revised) figures are issued by the relevant authority.
5. The CCT will confirm in writing once processing of the CPA or RoE adjustments have been completed including the effective date of the adjustments.
6. Where pricelist-based and other non-index based CPA requests are investigated and found to be not reasonable and market related, the CCT reserves the right to reject such requests. Where disputes arise with respect to such rejected requests the CCT reserves the right to procure the Goods from other available Suppliers until such time as the dispute is resolved.
7. Unless indicated otherwise in the relevant schedule below, all Purchase Orders issued on or after the effective date of the adjustment shall be issued at, and the Goods or Services supplied, invoiced and paid for at the adjusted prices. The relevant adjustment will not be applied to Purchase Orders issued prior to the effective date.

**F.1 (A) – FIRM PRICES**

***NOT APPLICABLE***

**F.1 (B) LOCAL SOUTH AFRICAN CONTENT – SEIFSA INDICES**

***NOT APPLICABLE***

**F.1 (C) LOCAL SOUTH AFRICAN CONTENT - SUPPLIER/ MANUFACTURER PRICE LIST/QUOTATIONS**

***NOT APPLICABLE***

## F.1 (D) LOCAL SOUTH AFRICAN CONTENT - STATS SA CONSUMER PRICE INDEX

1. Applicable where the Tenderer/Suppliers has indicated their tendered prices are subject to adjustment based on changes in the Statistics South Africa (STATS SA) Consumer Price Indices.
2. A minimum of 10% of the tender price as per C.4 Pricing Schedule shall be fixed and free of variation for the duration of the contract.
3. A total of 90% of the tender price as per C.4 Pricing Schedule shall be adjusted annually in accordance with clause 5 below.
4. The Contract Price(s) shall remain FIRM for the first 12 calendar months from date of Commencement Date of Contract and Suppliers are not permitted to requests CPA during this period.
5. The Contract Price(s) will thereafter be subject to adjustment annually based on the average percentage of change over 12 months as published by STATS SA: Consumer Price Index (P0141– Table B2 – CPI headline year-on-year rates) as follows:
  - 5.1 CPA applicable from the start of the 13<sup>th</sup> month to the end of the 24<sup>th</sup> month calculated as follows:
    - a. The base month for the price adjustment being three (3) calendar months prior to Commencement Date of Contract; and
    - b. The end month shall be three (3) calendar months prior to the 12<sup>th</sup> month.
  - 5.2 CPA applicable from the start of the 25<sup>th</sup> month to end of the 36<sup>th</sup> month calculated as follows:
    - a. The base month for the price adjustment shall be three (3) calendar months prior to the 13<sup>th</sup> month; and
    - b. The end month shall be three (3) calendar months prior to 24<sup>th</sup> month.
  - 5.3 The average CPI percentage will be calculated using the base month to the end month (both included) divided by the number of months. (12 months totalled/12 to achieve the average CPI)
6. 6 Subject to prior approval by the CCT delegated authority, in the event of any extension of the contract period, the CPA applicable beyond month 36<sup>th</sup> of the contract will follow the same principle in determining the base month (i.e. 3 calendar months prior to 25<sup>th</sup> month) and end date (3 calendar months prior to 36<sup>th</sup> month) as outlined above.

**F.1. (E) LOCAL SOUTH AFRICAN CONTENT – SECTORIAL DETERMINATION**

*NOT APPLICABLE*

**F.1. (F) GOODS AND/OR COMPONENTS IMPORTED FROM OUTSIDE OF SOUTH AFRICA  
RATE OF EXCHANGE PRICE VARIATIONS**

*NOT APPLICABLE*

**F.1. (G) GOODS AND/OR COMPONENTS IMPORTED FROM OUTSIDE OF SOUTH AFRICA -  
MANUFACTURER/SUPPLIER PRICE/QUOTATION LIST**
**1. Manufacturer's / Supplier's Pricelist / Quotation Based CPA – Imported Goods or Components:**

- 1.1 Tenderers with imported Goods or Components may claim contract price adjustment based on the overseas SUPPLIER'S / MANUFACTURER'S PRICE LISTS/ QUOTATION from the supplier or manufacturer of the tendered items.
- 1.2 In such cases the Tenderer is required to submit with his tender a copy of the original overseas Supplier / Manufacturer Pricelist / Quotation upon which his tender prices are based. Such pricelist / Quotation is required to be on the Letterhead of the Supplier / Manufacture, is to be dated, referenced and signed, and is to provide clear reference to the tender number or unambiguously indicate the relevant component.
- 1.3 The Tenderer is required to clearly reference each item quoted to the respective Tender Item Number indicated in C.4 Price Schedule by completing Table F.1 (G).1 below.

**Table F.1 (G).1: Price Schedule information for Imported Goods or Components - Manufacturers/Suppliers Price List(s)/Quotation**

Manufacturer/ Supplier Name	Price List Information		
	Price List/Quotation Date.	Price List/Quotation Reference Number	Pricelist applicable to Items as per C.4 Price Schedule

- 1.4 During the contract period, the Tenderer (now Supplier) must submit the request for price adjustment based on increases in pricelists of manufacturers/suppliers prior to the effective date of the increase in the pricelist.
- 1.5 The effective date of any price adjustment granted will be the first day of the month following the month during which the fully substantiated application for contract price adjustment is submitted or, by agreement between the Tenderer/Supplier and the CCT, a subsequent date on which the price adjustment will become effective.
- 1.6 In instances where the Supplier's price adjustment claimed is less than entitled, the lesser price will be accepted.
- 1.7 Only the difference in source supplier / manufacturer pricelist (actual cost, not percentage) may be adjusted and under no circumstances may the Tenderer/Supplier increase their profit margin.
- 1.8 The Tenderer/Supplier shall, when submitting claims for contract price adjustment, submit all of the documentation indicated below a minimum of two weeks prior to the effective date of the contract price adjustment:
- a) Copies of price lists upon which original tender prices were based (refer to Clause 1.2, Table F.1 (G).1 above) clearly indicating the item(s) according to C.4 Price Schedule.
  - b) The new price list (*from the same Supplier / Manufacturer as originally tendered*) on the relevant manufacturer/suppliers letterhead (with pamphlets, brochures and e-mail communication) clearly indicating the item(s) according to C.4 Price Schedule.

- c) Submit detailed calculations indicating how the “new” price is calculated. The calculations must be submitted in Excel, together with a signed, “PDF” version of the Excel spreadsheet. The example below – Table F.1(G).2, is what is required.
  - d) A covering letter on the Supplier’s letterhead requesting the CPA with the effective date of the claim.
- 1.9 The CCT will consider the request and either refer the request back for correction or additional information or approve the request.
- 1.10 The CCT will assess such pricelist based CPA claims and will only approve such claims that are confirmed to be reasonable and market related with reference to the source pricing information provided with the tender and with the CPA application
- 1.11 Approval of the CPA request including confirmation of the effective date, will be communicated to the Supplier in writing. The effective date will be as per clause 1.3 above.
- 1.12 The successful Tenderer/Supplier shall immediately upon notification of the commencement date of contract submit written application for approval of any adjusted unit prices for the Goods that may have been notified by the Supplier / Manufacturer of the Goods, together with the required supporting documentation. This application will be assessed in accordance with the process laid out above in order to determine approved contract prices at the commencement of the contract.
- 1.13 Failure to submit such application within two working weeks of commencement of contract shall result in the tendered unit prices being applied for initial orders placed following commencement of the contract.
- 1.14 In the event of a Supplier changing their Supplier / Manufacturer during the tenure of the contract, no request for price variations will be considered unless the Supplier has obtained prior approval from the City for the change of Supplier / Manufacturer. Such approval shall include technical approval by the Engineer of the goods supplied by the replacement Supplier / Manufacturer. Technical approval by the Engineer shall be a prerequisite for any change of Supplier / Manufacturer.

**Table F.1(G).2 – Pro Forma Table for Adjustments in price for Imported Goods or Components - Manufacturers/Suppliers Price List(s)/Quotation**

C.4 Price Schedule Item No.	Original Tender Price  (A)	Previous and New Price List Information					New Contract Price (Excl. VAT)  (A)+(D)
		Manufacturer/Supplier	Material no.	Price as per previous Manufacturer/Supplier Price List (Excl. Vat)  Price List Date: _____  (B)	Price as per new Supplier/Manufacturer Price List (Excl. Vat)  Price List Date: _____  (C)	Difference between the previous and new manufacturer Price list (C)-(B)  (D)	

OR

**2. Supplier Price List Variations for Suppliers Supplying Goods Imported by Another Party**

- 2.1 The Tenderers (now Supplier) that are not the director importer of the manufactured goods/components, and intend to purchase the goods from another supplier who in turn is importing the goods, may apply for Supplier / Manufacturer Pricelist / Quotation based CPA imported by a another Party.
- 2.2 In such cases the Tenderer is required to submit with his tender a copy of the original Supplier / Manufacturer Pricelist / Quotation upon which his tender prices are based. Such pricelist / Quotation is required to be on the Letterhead of the Supplier / Manufacture, is to be dated, referenced and signed, and is to provide clear reference to the tender number, exchange rate on which the quote is based and is required to clearly reference each item quoted to the respective Tender Item Number indicated in C.4 Price Schedule.
- 2.3 The tenderer shall further confirm the Manufacturer / supplier, Quotation date, exchange rate at date of quote and reference number and applicable tender Items by completing Table F.1(G).3 below.

**Table F.1 (G).3: Price Schedule information for Imported Goods or Components, imported by Another Party Manufacturers/Suppliers Price List(s)/Quotation**

Manufacturer/ Supplier Name	Price List Information			Pricelist applicable to Items as per C.4 Price Schedule
	Price List/Quotation Date.	Price List/Quotation Reference Number	Exchange Rate on which quote is based	
			_____ 1 : Rand _____	
			_____ 1 : Rand _____	
			_____ 1 : Rand _____	
			_____ 1 : Rand _____	

- 2.4 During the contract period, the Tenderer (now Supplier) must submit the request for price adjustment based on increases in pricelists of manufacturers/suppliers within seven calendar days of the date of the purchase order date.
- 2.5 The price adjustment claim will be fully substantiated and the approval will be limited to the relevant Purchase Order.
- 2.6 In instances where the Supplier's price adjustment claimed is less than entitled, the lesser price will be accepted.
- 2.7 Only the difference in source supplier / manufacturer pricelist (actual cost, not percentage) may be adjusted and under no circumstances may the Tenderer/Supplier increase their profit margin.
- 2.8 The Tenderer/Supplier shall, when submitting claims for contract price adjustment, submit all of the documentation indicated below a minimum of seven (7) days from date of purchase order:
- Copies of price lists upon which original tender prices were based (refer to Clause 2.2, Table 2 above) clearly indicating the item(s) according to C.4 Price Schedule.
  - The new price list (*from the same Supplier / Manufacturer as originally tendered*) on the relevant manufacturer/suppliers letterhead (with pamphlets, brochures and e-mail communication) clearly indicating the item(s) according to C.4 Price Schedule.

- c) Submit detailed calculations indicating how the “new” price is calculated.
- d) A covering letter on the Supplier’s letterhead requesting the CPA with the effective date of the claim.

- 2.9 The CCT will consider the request and either refer the request back for correction or additional information or approve the request.
- 2.10 The CCT will assess such pricelist based CPA claims and will only approve such claims that are confirmed to be reasonable and market related with reference to the source pricing information provided with the tender and with the CPA application
- 2.11 Approval of the CPA request for the relevant Purchase Order (refer to clause 2.5 above), will be communicated to the Supplier in writing.

**F.1. (H) GOODS AND/OR COMPONENTS IMPORTED FROM OUTSIDE OF SOUTH AFRICA -  
BASED ON FOREIGN INDICES**

***NOT APPLICABLE***

**Schedule F.2: Certificate of Authority for Partnerships/ Joint Ventures/ Consortiums**

**This schedule is to be completed if the tender is submitted by a partnership/joint venture/ consortium.**

1. We, the undersigned, are submitting this tender offer as a partnership/ joint venture/ consortium and hereby authorize Mr/Ms \_\_\_\_\_, of the authorised entity \_\_\_\_\_, acting in the capacity of Lead Partner, to sign all documents in connection with the tender offer and any contract resulting from it on the partnership/joint venture/ consortium’s behalf.
2. By signing this schedule the partners to the partnership/joint venture/ consortium:
  - 2.1 warrant that the tender submitted is in accordance with the main business and objectives of the partnership/joint venture/ consortium;
  - 2.2 agree that the CCT shall make all payments in terms of this Contract into the following bank account of the Lead Partner:  
 Account Holder: \_\_\_\_\_  
 Financial Institution: \_\_\_\_\_  
 Branch Code: \_\_\_\_\_  
 Account No.: \_\_\_\_\_
  - 2.3 agree that in the event that there is a change in the partnership/ joint venture/ consortium and/or should a dispute arise between the partnership/joint venture/ consortium partners, that the CCT shall continue to make any/all payments due and payable in terms of the Contract into the aforesaid bank account until such time as the CCT is presented with a Court Order or an original agreement (signed by each and every partner of the partnership/joint venture/ consortium) notifying the CCT of the details of the new bank account into which it is required to make payment.
  - 2.4 agree that they shall be jointly and severally liable to the CCT for the due and proper fulfilment by the successful tenderer/supplier of its obligations in terms of the Contract as well as any damages suffered by the CCT as a result of breach by the successful tenderer/supplier. The partnership/joint venture/ consortium partners hereby renounce the benefits of excussion and division.

SIGNED BY THE PARTNERS OF THE PARTNERSHIP/ JOINT VENTURE/ CONSORTIUM		
NAME OF FIRM	ADDRESS	DULY AUTHORISED SIGNATORY
Lead partner		Signature..... Name..... Designation.....
		Signature..... Name..... Designation.....
		Signature..... Name..... Designation.....
		Signature..... Name..... Designation.....

**Note: A copy of the Joint Venture Agreement shall be appended to *List of Other Documents Attached by Tenderer Schedule*.**

**Schedule F.3: Declaration for Procurement above R10 million**

If the value of the transaction is expected to exceed R10 million (VAT included) the tenderer shall complete the following questionnaire, attach the necessary documents and sign this schedule:

1. Are you by law required to prepare annual financial statements for auditing? **(Please mark with X)**

YES		NO	
-----	--	----	--

If YES, submit audited annual financial statements:

- (i) For the past three years, or
- (ii) Since the date of establishment of the tenderer (if established during the past three years)

By attaching such audited financial statements to **List of Other Documents Attached by Tenderer Schedule**.

2. Do you have any outstanding undisputed commitments for municipal services towards the CCT or other municipality in respect of which payment is overdue for more than 30 (thirty) days? **(Please mark with X)**

YES		NO	
-----	--	----	--

2.1 If NO, this serves to certify that the tenderer has no undisputed commitments for municipal services towards any municipality for more than three (3) (three) months in respect of which payment is overdue for more than 30 (thirty) days.

2.2 If YES, provide particulars:

3. Has any contract been awarded to you by an organ of state during the past five (5) years? **(Please mark with X)**

YES		NO	
-----	--	----	--

If YES, insert particulars in the table below including particulars of any material non-compliance or dispute concerning the execution of such contract. Alternatively attach the particulars to **List of Other Documents Attached by Tenderer** schedule in the same format as the table below:

Organ of State	Contract Description	Contract Period	Non-compliance/dispute (if any)

4. Will any portion of the goods or services be sourced from outside the Republic, and if so, what portion and whether any portion of payment from the CCT is expected to be transferred out of the Republic? **(Please mark with X)**

YES		NO	
-----	--	----	--

If YES, furnish particulars below

The tenderer hereby certifies that the information set out in this schedule and/or attached hereto is true and correct, and acknowledges that failure to properly and truthfully complete this schedule may result in steps being taken against the tenderer, the tender being disqualified, and/or (in the event that the tenderer is successful) the cancellation of the contract, restriction of the tenderer or the exercise by the CCT of any other remedies available to it.

\_\_\_\_\_  
Signature  
Print name:  
On behalf of the tenderer (duly authorised)

\_\_\_\_\_  
Date

## Schedule F.4: Preference Points Claim Form In Terms Of the Preferential Procurement Regulations 2022

### 1. GENERAL CONDITIONS

- 1.1 The following preference point systems are applicable to invitations to tender:
- the 80/20 system for requirements with a Rand value of up to R50 000 000 (all applicable taxes included); and
  - the 90/10 system for requirements with a Rand value above R50 000 000 (all applicable taxes included).

- 1.2 **To be completed by the organ of state**  
*[Delete whichever is not applicable for this tender]*

The applicable preference point system for this tender is the 90/10 preference point system.

- 1.3 Points for this tender (even in the case of a tender for income-generating contracts) shall be awarded for:
- (a) Price; and
  - (b) Specific Goals.

- 1.4 **To be completed by the organ of state:**

The maximum points for this tender are allocated as follows:

	<b>POINTS</b>
<b>PRICE</b>	90
<b>SPECIFIC GOALS</b>	10
<b>Total points for Price and SPECIFIC GOALS</b>	<b>100</b>

- 1.5 Failure on the part of a tenderer to submit proof or documentation required in terms of this tender to claim points for specific goals with the tender, will be interpreted to mean that preference points for specific goals are not claimed.
- 1.6 The organ of state reserves the right to require of a tenderer, either before a tender is adjudicated or at any time subsequently, to substantiate any claim in regard to preferences, in any manner required by the organ of state.

### 2. DEFINITIONS

The following definitions shall apply to this schedule:

- (a) "tender" means a written offer in the form determined by an organ of state in response to an invitation to provide goods or services through price quotations, competitive tendering process or any other method envisaged in legislation;
- (b) "price" means an amount of money tendered for goods or services, and includes all applicable taxes less all unconditional discounts;
- (c) "rand value" means the total estimated value of a contract in Rand, calculated at the time of bid invitation, and includes all applicable taxes;
- (d) "tender for income-generating contracts" means a written offer in the form determined by an organ of state in response to an invitation for the origination of income-generating contracts through any method envisaged in legislation that will result in a legal agreement between the organ of state and a third party that produces revenue for the organ of state, and includes, but is not limited to, leasing and disposal of assets and concession contracts, excluding direct sales and disposal of assets through public auctions; and
- (e) "The Act" means the Preferential Procurement Policy Framework Act, 2000 (Act No. 5 of 2000).

**3. FORMULAE FOR PROCUREMENT OF GOODS AND SERVICES****POINTS AWARDED FOR PRICE****THE 80/20 OR 90/10 PREFERENCE POINT SYSTEMS**

A maximum of 80 or 90 points is allocated for price on the following basis:

80/20 or 90/10

Or

Where

Ps = Points scored for price of tender under consideration

Pt = Price of tender under consideration

Pmin = Price of lowest acceptable tender

**4. FORMULAE FOR DISPOSAL OR LEASING OF STATE ASSETS AND INCOME GENERATING PROCUREMENT****POINTS AWARDED FOR PRICE**

A maximum of 80 or 90 points is allocated for price on the following basis:

80/20 or 90/10

Or

Where:

Ps = Points scored for price of tender under consideration

Pt = Price of tender under consideration

Pmax = Price of highest acceptable tender

**5. POINTS AWARDED FOR SPECIFIC GOALS**

5.1 In terms of Regulation 4(2); 5(2); 6(2) and 7(2) of the Preferential Procurement Regulations, preference points must be awarded for specific goals stated in the tender. For the purposes of this tender the tenderer will be allocated points based on the goals stated in table 1 below as may be supported by proof/documentation stated in the conditions of this tender:

5.2 In cases where organs of state intend to use Regulation 3(2) of the Regulations, which states that, if it is unclear whether the 80/20 or 90/10 preference point system applies, an organ of state must, in the tender documents, stipulate in the case of—

- (a) an invitation for tender for income-generating contracts, that either the 80/20 or 90/10 preference point system will apply and that the highest acceptable tender will be used to determine the applicable preference point system; or
- (b) any other invitation for tender, that either the 80/20 or 90/10 preference point system will apply and that the lowest acceptable tender will be used to determine the applicable preference point system,

then the organ of state must indicate the points allocated for specific goals for both the 90/10 and 80/20 preference point system.

**Table 1: Specific Goals (SG) – Points Allocated and Claimed**

Tenderers must indicate the preference points claimed for each specific goal applicable to them, for the purposes of this tender.

(Note to organs of state: Where either the 90/10 preference point system is applicable, corresponding points must also be indicated as such.)

The specific goals allocated points in terms of this tender	To be Completed by the Organ of State	To be Completed by the Tenderer
	Number of points Allocated (90/10 system)	Number of points claimed (90/10 system)
Promotion of Micro and Small Enterprises	4	
Enterprise Supplier Development and Socio-Economic Development	3	
Skills Development <u>OR</u> Employee Share Scheme	3	

DECLARATION WITH REGARD TO COMPANY/FIRM

5.3 Name of company/firm.....

5.4 Company registration number: .....

5.5 TYPE OF COMPANY/ FIRM

- Partnership/Joint Venture / Consortium
- One-person business/sole propriety
- Close corporation
- Public Company
- Personal Liability Company
- (Pty) Limited
- Non-Profit Company
- State Owned Company

[Tick applicable box]

5.6 I, the undersigned, who is duly authorised to do so on behalf of the company/firm, certify that the points claimed, based on the specific goals as advised in the tender, qualifies the company/ firm for the preference(s) shown and I acknowledge that:

- i) The information furnished is true and correct;
- ii) The preference points claimed are in accordance with the General Conditions as indicated in paragraph 1 of this form;
- iii) In the event of a contract being awarded as a result of points claimed as shown in paragraphs 4.1 and 4.2, the Supplier may be required to furnish documentary proof to the satisfaction of the organ of state that the claims are correct;
- iv) If the specific goals have been claimed or obtained on a fraudulent basis or any of the conditions of contract have not been fulfilled, the organ of state may, in addition to any other remedy it may have –
  - (a) disqualify the person from the tendering process;
  - (b) recover costs, losses or damages it has incurred or suffered as a result of that person's conduct;
  - (c) cancel the contract and claim any damages which it has suffered as a result of having to make less favourable arrangements due to such cancellation;
  - (d) recommend that the tenderer or Supplier, its shareholders and directors, or only the shareholders and directors who acted on a fraudulent basis, be restricted from obtaining business from any organ of state for a period not exceeding 10 years, after the audi alteram partem (hear the other side) rule has been applied; and
  - (e) forward the matter for criminal prosecution, if deemed necessary.

<i>Signature of Tenderer</i>	<i>Date</i>	<i>Name and Surname</i>	<i>Address</i>

For official use.		
<b>SIGNATURE OF CCT OFFICIALS AT TENDER OPENING</b>		
1.	2.	3.

**Table 2: Specific Goals – Declaration by the Tenderer**

Tenderers must complete this table to declare the amounts and percentages applicable to the specific goals they are claiming.

NB: In completing Table 2 below, please consult **Notes for Verification** below

The specific goals allocated points in terms of this tender	To be Completed by the Tenderer	
	Refer to “Notes for verification”	Amount Declared (excluding VAT)
<b><u>SG1</u></b> Promotion of Micro and Small Enterprises	(i) Total Turnover	
<b><u>SG2</u></b> Enterprise Supplier Development and Socio Economic Development	(ii) Total Enterprise Supplier Development Expenditure	
	(iii) Total Socio Economic Development Expenditure	
	(iv) Total Expenditure	
<b><u>SG3.1</u></b> Skills Development	(v) Total Skills Development Expenditure	
	(vi) Total Profit	
OR <b><u>SG3.2</u></b> Employee Share Scheme	(vii) Employee Share Scheme Ownership %	

**Tenderer Confirmation:**

I confirm that the amounts declared in Table 2 above are accurate and in accordance with the *‘The Broad-Based Black Economic Empowerment (B-BBEE) Act 53 of 2003, as amended.* .

<b>Signature of Tenderer (Authorised to represent the tenderer)</b>	<b>Date</b>	<b>Name and Surname</b>	<b>Address</b>

**Notes for Verification:**

All amounts disclosed should be as per the most recent Annual Financial Statements (not older than 12 months) and defined as per the B-BBEE Act

- SG1 – Specific Goal 1  
**Promotion of Micro and Small Enterprises**  
 (i) Total Turnover  
 Micro enterprises with a turnover of up to R20million and Small enterprises with a turnover up to R80 million, as per National Small Enterprise Act, 1996 (Act No.102 of 1996)
- SG2 – Specific Goal 2  
**Enterprise Supplier Development and Socio-Economic Development**  
 (ii) Total Enterprise Supplier Development Expenditure  
 Qualifying expenditure as defined in the B-BBEE Act: Statement 400 "THE GENERAL PRINCIPLES FOR MEASURING ENTERPRISE AND SUPPLIER DEVELOPMENT"  
  
 (iii) Total Enterprise Socio Economic Development Expenditure  
 Qualifying expenditure as defined in the B-BBEE Act: Statement 500 "THE GENERAL PRINCIPLES FOR MEASURING THE SOCIO - ECONOMIC DEVELOPMENT ELEMENT"  
  
 (iv) Total Expenditure  
 Total Expenditure as per the most recent Annual Financial Statements (not older than 12 months)
- SG3.1 – Specific Goal 3  
**Skills Development**  
 (v) Total Skills Development Expenditure  
 Qualifying expenditure as defined in the B-BBEE Act: Statement 300 "THE GENERAL PRINCIPLES FOR MEASURING SKILLS DEVELOPMENT"  
  
 (vi) Total Profit  
 Total Profit as per the most recent Annual Financial Statements (not older than 12 months)
- SG3.2 – Specific Goal 3  
**Employee Share Scheme**  
 (vii) Employee Share Scheme Ownership %  
 Total employee ownership as per employee share certificate at the date of tender closing.

The below table (Table 3) must be completed by a B-BBEE Verification Agency (\*Note 1) **OR** Commissioner of Oaths  
 (Refer to \*Note 3.2 for the detailed declaration):

**Table 3:**

<b>Signature and Stamp</b>	<b>Date</b>	<b>Name and Surname</b>	<b>Address</b>

**\*Note 1**

1.1 Tendering entity that undergoes B-BBEE verification

- Where a tendering entity undergoes B-BBEE verification, a B-BBEE certificate valid as at the date of tender closing, must be attached to the bid submission or must be made available upon request within the specified period.
- All amounts disclosed in Table 2, should be amounts used in the B-BBEE verification process undergone by the tendering entity
- The B-BBEE verification agency must complete Table 3 above, to confirm the following amounts disclosed by the bidder in Table 2:
  - (ii) Total Enterprise Supplier Development Expenditure;
  - (iii) Total Socio Economic Development Expenditure;
  - (v) Total Skills Development Expenditure
- Where the tendering entity is a Joint Venture/ Consortium, the amounts in Table 2 must be consolidated, with an accompanying consolidated B-BBEE certificate valid as at the date of tender closing must be attached to the bid submission or must be made available upon request within the specified period.

1.2 If the tendering entity does not undergo B-BBEE verification and qualifies as a B-BBEE Qualifying Small Enterprise (QSE) and Exempted Micro-Enterprises (EME)

- Table 3 must be completed by a Commissioner of Oaths to confirm the following amounts disclosed by the bidder in Table 2:
  - (ii) Total Enterprise Supplier Development Expenditure;
  - (iii) Total Socio Economic Development Expenditure;
  - (v) Total Skills Development Expenditure

**\*Note 2**

2.1 The tendering entity must attach with the bid submission or must be made available upon request within the specified period; the most recent (where applicable) audited financial statements to enable validation of the following amounts disclosed by the bidder in Table 2:

- (i) Total Turnover
- (iv) Total Expenditure
- (vi) Total Profit

2.2 Companies who are required to be audited by legislation, must submit audited financial statements, not older than 12 months with the bid submission or must be made available upon request within the specified period.

**\*Note 3**

Sworn affidavit to be deposited by the Commissioner of Oaths to the QSE or EME.

I, the undersigned,

<b>Full Name and Surname</b> <i>(Authorised to represent the tenderer)</i>	
<b>Identity Number</b>	

Hereby declare under oath as follows

3.1 The contents of this statement are to the best of my knowledge a true reflection of facts.

3.2 I am a Member/ Director/ Owner of the following enterprise and am duly authorised to act on its behalf.

<b>Enterprise Name:</b>	
<b>Trading Name (If Applicable):</b>	
<b>Registration Number:</b>	
<b>Enterprise Physical Address:</b>	
<b>Type of Entity (CC, Pty (Ltd), Sole Prop etc):</b>	
<b>Nature of Business:</b>	

3.3 I hereby declare under oath that based on the Financial Statements / Management Accounts and information available on the latest financial year end \_\_\_\_\_

3.3.1 The annual Total Revenue was less than R50 000 000.00 (Fifty Million Rand);

3.3.2 The following amounts disclosed in Table 2 are accurate, complete, consistent with the BBBEE Act (see Notes for Verification) and based on the Financial Statements / Management Accounts and information available on the latest financial year end \_\_\_\_\_

<b>As per Table 2</b>	<b>Amount Declared (excluding VAT)</b>
(ii) Total Enterprise Supplier Development Expenditure	
(iii) Total Socio Economic Development Expenditure	
(iv) Total Expenditure	
(v) Total Skills Development Expenditure	

As per Table 2	Amount Declared (excluding VAT)
(vi) Total Profit	
(vii) Employee Share Scheme Ownership %	

3.4 I know and understand the contents of this affidavit and I have no objection to take the prescribed oath and consider the oath binding on my conscience and on the owners of the enterprise which I represent I this matter.

3.5 The sworn affidavit will be valid for a period of 12 months from the date signed by the commissioner.

Commissioner of Oaths  
Signature, Date and Stamp

Deponent Signature and Date

3.6 KEY NOTES OF DETERMINING VALIDITY OF SWORN AFFIDAVITS

<p><b>BBBEE Certificates/ Sworn Affidavits</b></p>	<p>Returnable for declaration requirement must be attached with the bid submission or must be made available upon request within the specified period</p> <ul style="list-style-type: none"> <li>- Certified and Valid copy of BBBEE Certificate issued by a SANAS Accredited Verification Agent, or</li> <li>- Certified and Valid copy of Sworn Affidavit for either EME or QSE (see key notes below to determine Validity of a Sworn Affidavit); or</li> <li>- Valid copy of BBBEE Certificate issued by CIPC for EME's only</li> </ul> <p><b>KEY NOTES OF DETERMINING VALIDITY OF SWORN AFFIDAVITS</b></p> <p><b>Tenderers submitting Sworn Affidavits must ensure that the affidavits meet the following key pointers to ensure their validity:</b></p> <p>(a) Name/s of deponent as they appear in the identity document and the identity number.</p> <p>(b) Designation of the deponent as the Director/ Member must be indicated in order to know that person is duly authorised to depose of an affidavit <b>(mark the applicable</b></p>
--	--

	<p><b>option).</b></p> <p>(c) Name of enterprise as per enterprise registration documents issued by CIPC, where applicable, and enterprise business address.</p> <p>(d) Amounts as per Table 2 must be inserted <b>(No blank spaces to be left).</b></p> <p>(e) Indicate total revenue for the year under review and whether it is based on audited financial statements or management accounts <b>(mark the applicable option).</b></p> <p>(f) Financial year end as per the enterprise's registration documents, which was used to determine the total revenue (financial year end to be stipulated by day/ month/ year).</p> <p>(g) Date deponent signed and date of Commissioner of Oath must be the same. (The sworn affidavit must be signed in the presence of the Commissioner of Oath. Furthermore the Commissioner must also sign ad stamp).</p> <p>(h) Commissioner of Oath cannot be an employee or ex officio of the enterprise because, a person cannot by law, commission a sworn affidavit in which they have an interest.</p> <p>If the relevant documentation/ information as stipulated in the enquiry is not submitted and/or does not meet the above requirements; tenderers will be disqualified.</p>
--	---

For official use.		
<b>SIGNATURE OF CCT OFFICIALS AT TENDER OPENING</b>		
1.	2.	3.

<b>Schedule F.5: Declaration of Interest – State Employees (MBD 4 amended)</b>
--

1. No bid will be accepted from:
  - 1.1 persons in the service of the state<sup>1</sup>, or
  - 1.2 if the person is not a natural person, of which any director, manager or principal shareholder or stakeholder is in the service of the state, or
  - 1.3 from persons, or entities of which any director, manager or principal shareholder or stakeholder, has been in the service of the City of Cape Town (CCT) during the previous twelve (12) months, or
  - 1.4 from an entity who has employed a former CCT employee who was at a level of T14 or higher at the time of leaving the CCT's employ and involved in any of the CCT's bid committees for the bid submitted, if:
    - 1.4.1 the CCT employee left the CCT's employment voluntarily, during the previous twelve (12) months;
  - 1.5 a person who was a CCT employee, or an entity that employs a CCT employee, if
    - 1.5.1 the CCT employee left the CCT's employment whilst under investigation for alleged misconduct, or
    - 1.5.2 was facing disciplinary action or potential disciplinary action by the CCT, or
    - 1.5.3 was involved in a dispute against the CCT during the previous thirty six (36) months.
  
2. Any person, having a kinship with persons in the service of the state, including a blood relationship, may make an offer or offers in terms of this invitation to bid. In view of possible allegations of favouritism, should the resulting bid, or part thereof, be awarded to persons connected with or related to persons in service of the state, it is required that the tenderer or their authorised representative declare their position in relation to the evaluating/adjudicating authority.
  
3. In order to give effect to the above, the following questionnaire must be completed and submitted with the bid.
  - 3.1 Full Name of tenderer or his or her representative: \_\_\_\_\_
  - 3.2 Identity Number: \_\_\_\_\_
  - 3.3 Position occupied in the Company (director, trustee, shareholder<sup>2</sup>): \_\_\_\_\_
  - 3.4 Company or Close Corporation Registration Number: \_\_\_\_\_
  - 3.5 Tax Reference Number: \_\_\_\_\_
  - 3.6 VAT Registration Number: \_\_\_\_\_
  - 3.7 The names of all directors / trustees / shareholders members, their individual identity numbers and state employee numbers must be indicated in paragraph 4 below.
  - 3.8 Are you presently in the service of the state? **YES / NO**
    - 3.8.1 If yes, furnish particulars: \_\_\_\_\_
  - 3.9 Have you been in the service of the state for the past twelve months? **YES / NO**
    - 3.9.1 If yes, furnish particulars: \_\_\_\_\_
  - 3.10 Do you have any relationship (family, friend, other) with persons in the service of the state and who may be involved with the evaluation and or adjudication of this bid? **YES / NO**
    - 3.10.1 If yes, furnish particulars: \_\_\_\_\_
  - 3.11 Are you, aware of any relationship (family, friend, other) between any other tenderer and any persons in the service of the state who may be involved with the evaluation and or adjudication of this bid? **YES / NO**
    - 3.11.1 If yes, furnish particulars: \_\_\_\_\_
  - 3.12 Are any of the company's directors, trustees, managers, principle shareholders or stakeholders in service of the state? **YES / NO**
    - 3.12.1 If yes, furnish particulars: \_\_\_\_\_

- 3.13 Are any spouse, child or parent of the company's directors, trustees, managers, principle shareholders or stakeholders in service of the state? **YES / NO**  
 3.13.1 If yes, furnish particulars: \_\_\_\_\_
- 3.14 Do you or any of the directors, trustees, managers, principle shareholders, or stakeholders of this company have any interest in any other related companies or business whether or not they are bidding for this contract? **YES / NO**  
 3.14.1 If yes, furnish particulars: \_\_\_\_\_
- 3.15 Have you, or any of the directors, trustees, managers, principle shareholders, or stakeholders of this company been in the service of the CCT in the past twelve months? **YES / NO**  
 3.15.1 If yes, furnish particulars: \_\_\_\_\_
- 3.16 Do you have any employees who was in the service of the CCT at a level of T14 or higher at the time they left the employ of the CCT, and who was involved in any of the CCT's bid committees for this bid? **YES / NO**  
 3.16.1 If yes, furnish particulars: \_\_\_\_\_

4. Full details of directors / trustees / members / shareholders

Full Name	Identity Number	State Employee Number

If the above table does not sufficient to provide the details of all directors / trustees / shareholders, please append full details to the tender submission.

The tenderer hereby certifies that the information set out in this schedule and/or attached hereto is true and correct, and acknowledges that failure to properly and truthfully complete this schedule may result in steps being taken against the tenderer, the tender being disqualified, and/or (in the event that the tenderer is successful) the cancellation of the contract, restriction of the tenderer or the exercise by the CCT of any other remedies available to it.

\_\_\_\_\_  
 Signature  
 Print name:  
 On behalf of the tenderer (duly authorised)

\_\_\_\_\_  
 Date

**'MSCM Regulations: "in the service of the state" means to be –**

- (a) a member of –
  - (i) any municipal council;
  - (ii) any provincial legislature; or
  - (iii) the national Assembly or the national Council of provinces;
- (b) a member of the board of directors of any municipal entity;
- (c) an official of any municipality or municipal entity;
- (d) an employee of any national or provincial department, national or provincial public entity or constitutional institution within the meaning of the Public Finance Management Act, 1999 (Act No.1 of 1999);
- (e) an executive member of the accounting authority of any national or provincial public entity; or
- (f) an employee of Parliament or a provincial legislature.

<sup>2</sup> Shareholder" means a person who owns shares in the company and is actively involved in the management of the company or business and exercises control over the company.

**Schedule F.6: Conflict of Interest Declaration**

1. The tenderer shall declare whether it has any conflict of interest in the transaction for which the tender is submitted. **(Please mark with X)**

YES		NO	
-----	--	----	--

1.1 If yes, the tenderer is required to set out the particulars in the table below:

2. The tenderer shall declare whether it has directly or through a representative or intermediary promised, offered or granted:

2.1 Any inducement or reward to the CCT for or in connection with the award of this contract; or

2.2 Any reward, gift, favour or hospitality to any official or any other role player involved in the implementation of the supply chain management policy. **(Please mark with X)**

YES		NO	
-----	--	----	--

If yes, the tenderer is required to set out the particulars in the table below:

***Should the tenderer be aware of any corrupt or fraudulent transactions relating to the procurement process of the CCT, please contact the following:***

***The CCT's anti-corruption hotline at 0800 32 31 30 (toll free)***

The tenderer hereby certifies that the information set out in this schedule and/or attached hereto is true and correct, and acknowledges that failure to properly and truthfully complete this schedule may result in steps being taken against the tenderer, the tender being disqualified, and/or (in the event that the tenderer is successful) the cancellation of the contract, restriction of the tenderer or the exercise by the CCT of any other remedies available to it.

\_\_\_\_\_  
 Signature  
 Print name:  
 On behalf of the tenderer (duly authorised)

\_\_\_\_\_  
 Date

## Schedule F.7: Declaration of Tenderer's Past Supply Chain Management Practices (MBD 8)

Where the entity tendering is a partnership/joint venture/consortium, each party to the partnership/joint venture/consortium must sign a declaration in terms of the Municipal Finance Management Act, Act 56 of 2003, and attach it to this schedule.

- 1 The tender offer of any tenderer may be rejected if that tenderer or any of its directors/members have:**
- a) abused the municipality's / municipal entity's supply chain management system or committed any fraudulent conduct in relation to such system;
  - b) been convicted for fraud or corruption during the past five years;
  - c) willfully neglected, reneged on or failed to comply with any government, municipal or other public sector contract during the past five years; or
  - d) been listed in the Register for Tender Defaulters in terms of section 29 of the Prevention and Combating of Corrupt Activities Act (No 12 of 2004) or Database of Restricted Suppliers.
- 2 In order to give effect to the above, the following questionnaire must be completed and submitted with the bid.**

Item	Question	Yes	No
2.1	<p><b>Is the tenderer or any of its directors/members listed on the National Treasury's Database of Restricted Suppliers as companies or persons prohibited from doing business with the public sector?</b></p> <p>(Companies or persons who are listed on this Database were informed in writing of this restriction by the Accounting Officer/Authority of the institution that imposed the restriction after the <i>audi alteram partem</i> rule was applied).</p> <p><b>The Database of Restricted Suppliers now resides on the National Treasury's website (<a href="http://www.treasury.gov.za">www.treasury.gov.za</a>) and can be accessed by clicking on its link at the bottom of the home page.</b></p>	Yes <input type="checkbox"/>	No <input type="checkbox"/>
2.1.1	If so, furnish particulars:		
2.2	<p>Is the tenderer or any of its directors/members listed on the Register for Tender Defaulters in terms of section 29 of the Prevention and Combating of Corrupt Activities Act (No 12 of 2004) or Database of Restricted Suppliers?</p> <p><b>The Register for Tender Defaulters can be accessed on the National Treasury's website (<a href="http://www.treasury.gov.za">www.treasury.gov.za</a>) by clicking on its link at the bottom of the home page.</b></p>	Yes <input type="checkbox"/>	No <input type="checkbox"/>
2.2.1	If so, furnish particulars:		
2.3	<p>Was the tenderer or any of its directors/members convicted by a court of law (including a court of law outside the Republic of South Africa) for fraud or corruption during the past five years?</p>	Yes <input type="checkbox"/>	No <input type="checkbox"/>
2.3.1	If so, furnish particulars:		

Item	Question	Yes	No
2.4	Does the tenderer or any of its directors owe any municipal rates and taxes or municipal charges to the municipality / municipal entity, or to any other municipality / municipal entity, that is in arrears for more than three months?	Yes <input type="checkbox"/>	No <input type="checkbox"/>
2.4.1	If so, furnish particulars:		
2.5	Was any contract between the tenderer and the municipality / municipal entity or any other organ of state terminated during the past five years on account of failure to perform on or comply with the contract?	Yes <input type="checkbox"/>	No <input type="checkbox"/>
2.5.1	If so, furnish particulars:		

The tenderer hereby certifies that the information set out in this schedule and/or attached hereto is true and correct, and acknowledges that failure to properly and truthfully complete this schedule may result in steps being taken against the tenderer, the tender being disqualified, and/or (in the event that the tenderer is successful) the cancellation of the contract,, restriction of the tenderer or the exercise by the CCT of any other remedies available to it.

\_\_\_\_\_  
 Signature  
 Print name:  
 On behalf of the tenderer (duly authorised)

\_\_\_\_\_  
 Date

**Schedule F.8: Authorisation for the Deduction of Outstanding Amounts Owed to the CCT**

To: THE CITY MANAGER, City of Cape Town

From: \_\_\_\_\_  
(Name of tenderer)

**RE: AUTHORISATION FOR THE DEDUCTION OF OUTSTANDING AMOUNTS OWED TO THE CCT**

The tenderer:

- a) hereby acknowledges that according to SCM Regulation 38(1)(d)(i) the City Manager may reject the tender of the tenderer if any municipal rates and taxes or municipal service charges owed by the tenderer (or any of its directors/members/partners) to the CCT, or to any other municipality or municipal entity, are in arrears for more than 3 (three) months; and
- b) therefore hereby agrees and authorises the CCT to deduct the full amount outstanding by the Tenderer or any of its directors/members/partners from any payment due to the tenderer; and
- c) confirms the information as set out in the tables below for the purpose of giving effect to b) above;

Physical Business address(es) of the tenderer	Municipal Account number(s)	Inside the CCT municipal boundary (Yes/No)

If there is not enough space for all the names, please attach the information to **List of other documents attached by tenderer** schedule in the same format:

Name of Director / Member / Partner	Identity Number	Physical residential address of Director / Member / Partner	Municipal Account number(s)	Inside the CCT municipal boundary (Yes/No)

The tenderer hereby certifies that the information set out in this schedule and/or attached hereto is true and correct, and acknowledges that failure to properly and truthfully complete this schedule may result in steps being taken against the tenderer, the tender being disqualified, and/or (in the event that the tenderer is successful) the cancellation of the contract, restriction of the tenderer or the exercise by the CCT of any other remedies available to it.

\_\_\_\_\_  
Signature  
Print name:  
On behalf of the tenderer (duly authorised)

\_\_\_\_\_  
Date

<b>Schedule F.9: Certificate of Independent Tender Determination</b>
--

I, the undersigned, in submitting this tender number [2G/2026/27 and tender description: **TERM TENDER OF THE SUPPLY AND DELIVERY, INSTALLATION OF NEW OUTDOOR EXERCISE EQUIPMENT AND THE REPAIRS TO EXISTING OUTDOOR EXERCISE EQUIPMENT** in response to the tender invitation made by THE CCT, do hereby make the following statements, which I certify to be true and complete in every respect:

I certify, on behalf of: \_\_\_\_\_ (Name of tenderer) that:

1. I have read and I understand the contents of this Certificate;
2. I understand that this tender will be disqualified if this Certificate is found not to be true and complete in every respect;
3. I am authorised by the tenderer to sign this Certificate, and to submit this tender, on behalf of the tenderer;
4. Each person whose signature appears on this tender has been authorised by the tenderer to determine the terms of, and to sign, the tender on behalf of the tenderer;
5. For the purposes of this Certificate and this tender, I understand that the word 'competitor' shall include any individual or organisation other than the tenderer, whether or not affiliated with the tenderer, who:
  - (a) has been requested to submit a tender in response to this tender invitation;
  - (b) could potentially submit a tender in response to this tender invitation, based on their qualifications, abilities or experience; and
  - (c) provides the same goods and services as the tenderer and/or is in the same line of business as the tenderer.
6. The tenderer has arrived at this tender independently from and without consultation, communication, agreement or arrangement with any competitor. However, communication between partners in a joint venture or consortium<sup>1</sup> will not be construed as collusive price quoting.
7. In particular, without limiting the generality of paragraphs 5 and 6 above, there has been no consultation, communication, agreement or arrangement with any competitor regarding:
  - (a) prices;
  - (b) geographical area where product or service will be rendered (market allocation);
  - (c) methods, factors or formulas used to calculate prices;
  - (d) the intention or decision to submit or not to submit a tender;
  - (e) the submission of a tender which does not meet the specifications and conditions of the tender; or
  - (f) tendering with the intention not to win the contract.
8. In addition, there have been no consultations, communications, agreements or arrangements with any competitor regarding the quality, quantity, specifications and conditions or delivery particulars of the products or services to which this tender invitation relates.
9. The terms of this tender have not been and will not be disclosed by the tenderer, directly or indirectly, to any competitor, prior to the date and time of the official tender opening or of the awarding of the contract.
10. I am aware that, in addition and without prejudice to any other remedy provided to combat any restrictive practices related to tenders and contracts, tenders that are suspicious will be reported to the Competition Commission for investigation and possible imposition of administrative penalties in terms of section 59 of the Competition Act, Act 89 of 1998, and/o/r may be reported to the National Prosecuting Authority (NPA) for criminal investigation, and/or may be restricted from conducting business with the public sector for a period not exceeding 10 (ten) years in terms of the Prevention and Combating of Corrupt Activities Act, Act 12 of 2004, or any other applicable legislation.

\_\_\_\_\_  
Signature

Print name:

On behalf of the tenderer (duly authorised)

\_\_\_\_\_  
Date

**(<sup>1</sup> Consortium: Joint venture or Consortium means an association of persons for the purpose of combining their expertise, property, capital, efforts, skill and knowledge in an activity for the**



**Schedule F.11: List of Other Documents Attached By Tenderer**

The tenderer has attached to this schedule, the following additional documentation:

	<b>Date of Document</b>	<b>Title of Document or Description (refer to clauses / schedules of this tender document where applicable)</b>
1.		
2.		
3.		
4.		
5.		
6.		
7.		
8.		
9.		
10.		
11.		
12.		
13.		
14.		
15.		
16.		
17.		

Attach additional pages if more space is required.

\_\_\_\_\_  
Signature  
Print name:  
On behalf of the tenderer (duly authorised)

\_\_\_\_\_  
Date

**Schedule F.12: Record of Addenda to Tender Documents**

We confirm that the following communications received from the CCT before the submission of this tender offer, amending the tender documents, have been taken into account in this tender offer:

	<b>Date</b>	<b>Title or Details</b>
1.		
2.		
3.		
4.		
5.		
6.		
7.		
8.		
9.		
10.		

Attach additional pages if more space is required.

\_\_\_\_\_  
Signature  
Print name:  
On behalf of the tenderer (duly authorised)

\_\_\_\_\_  
Date

**Schedule F13: Information to Be Provided With the Tender**

The following information shall be provided with the Tender:

1. Quality Control Procedures to be Utilised. – See Schedule F.13.1: Quality Control Procedure
2. Drawings and Sample Examples – See Schedule F.13.2: Gym Equipment Drawings and Sample Examples  
Quality Control Procedure
3. Schedules to be returned – See and complete Schedule F.13.3: Schedule F13.3 : Schedules
4. Evaluation Criteria – See Schedule F.13.4: Schedule F13.4 : Evaluation Criteria
5. Region Diagram – See Schedule F.13.5: Schedule F13.5 : Region Diagram
6. Indication of Region (Area) Tendering for – See and complete Schedule F.13.6: Schedule F13.6 : Indication of  
Region (Area) Tendering for

\_\_\_\_\_  
Signature  
Print name:  
On behalf of the tenderer (duly authorised)

\_\_\_\_\_  
Date

**Schedule F13.1 : Quality Control Procedure**

**ANNEXURE 1: Quality Control Procedures**

<b>QUALITY CONTROL PROCEDURE</b>		<b>WORKSHOP FABRICATION INSPECTIONS</b>		 CITY OF CAPE TOWN ISIXEKO SASEKAPA STAD KAAPSTAD
<b>QCP 1</b>		<b>RECREATION AND PARKS</b>	Version: 1	Page 136 of 156
<b>COMPILED BY: C3PM, ESU</b>			<b>APPROVED BY:</b>	

WORKSHOP FABRICATION INSPECTION

INSPECTION CHECKS	YES	NO
Workshop has a copy of the Works Project details and all drawings		
All steel work appears to be supplied as per specifications.		
Service provider confirms all dimensions have been checked		
Steel cutting was done cleanly and steelwork properly prepared before welding		
Surface preparation was carried out correctly before any welding		
Tack welding was done on the structure to ensure alignment		
Welding appears good quality and free of pin holes, weld splatter and flux		
Grinding of welds has taken place to improve finish without compromising weld		
For galvanising, sufficient size hole in the top so no air can get trapped - if in doubt make more holes (imagine how it will be hung and dipped)		
For galvanising, sufficient size hole at the bottom to allow the zinc to flow		
There are no stickers, sticker glue, oil, koki, paint and boiler maker yellow chalk?		
There are no sealed air pockets/butt welded corners		
Any white chalk or tippex?		
Fabrication is in order and ready to proceed to coating		
<b>COMMENTS</b>		

DETAILS	
WORKSHOP FABRICATION	
Date	
Project / Works Package Ref	
CCT Rep - Name & Signature	
Contractor Company	
Contractor Rep - Name & Signature	

\_\_\_\_\_  
 Signature  
 Print name:  
 On behalf of the tenderer (duly authorised)

\_\_\_\_\_  
 Date

**Schedule F13.2 : Gym Equipment Drawings and Sample Examples**

Item 1: Twin Walker

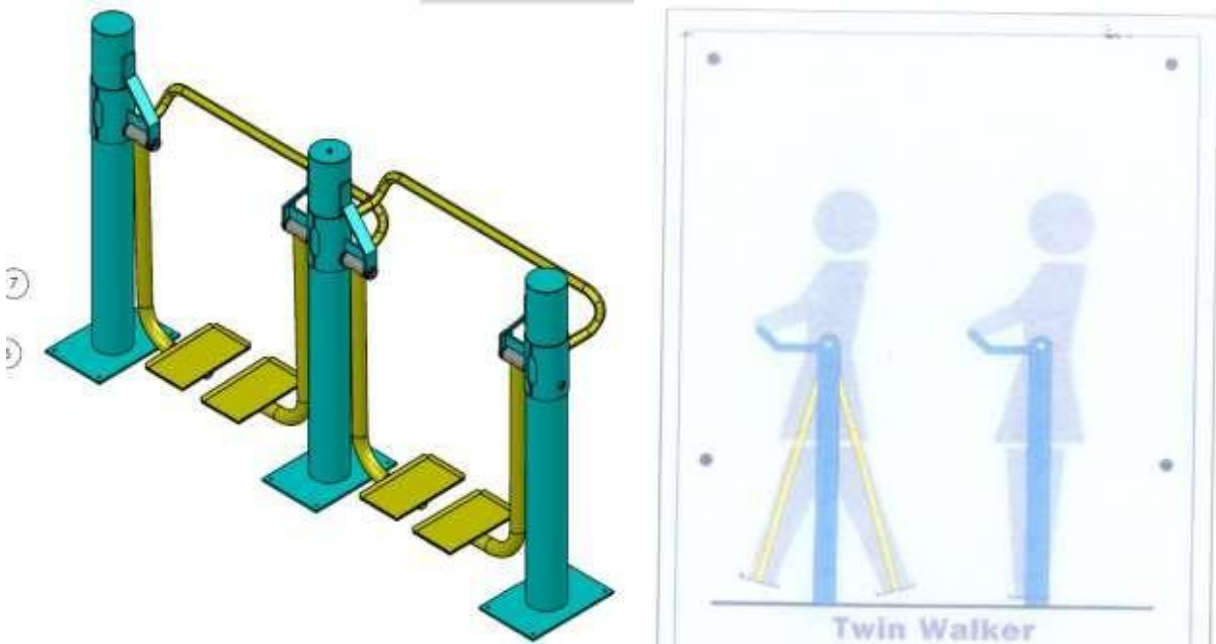

Item 2: Double Walker

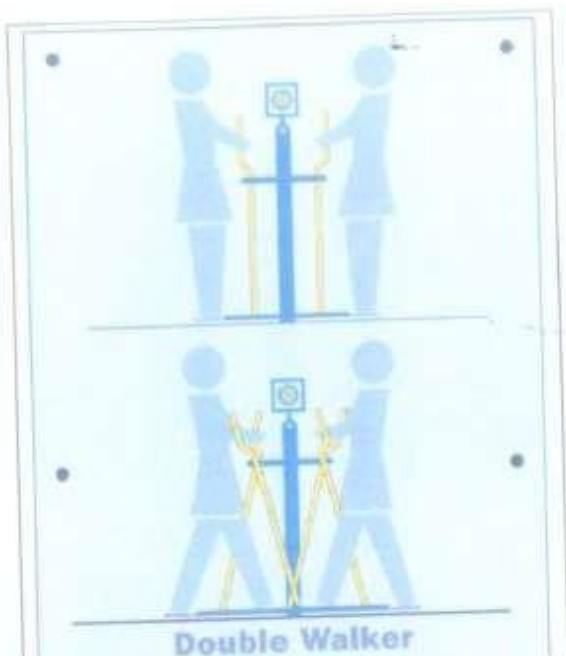

Item 3: Twin Push-up frame:

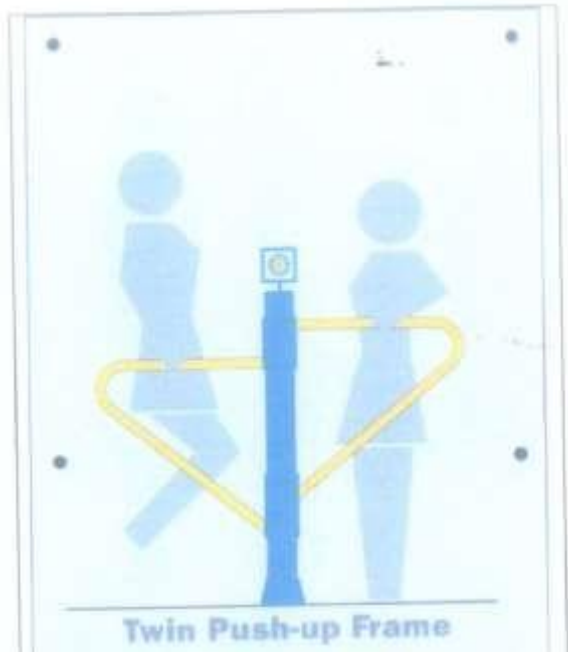
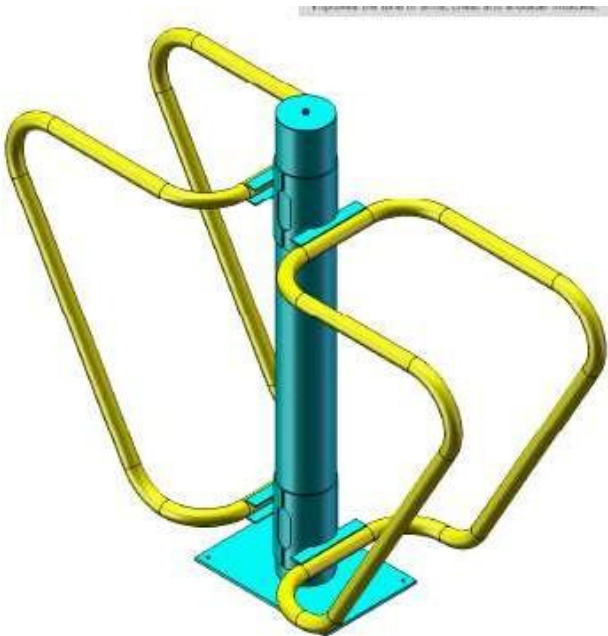

Item 4: Double twister:



Item 5: Twin Tai – Chi wheel

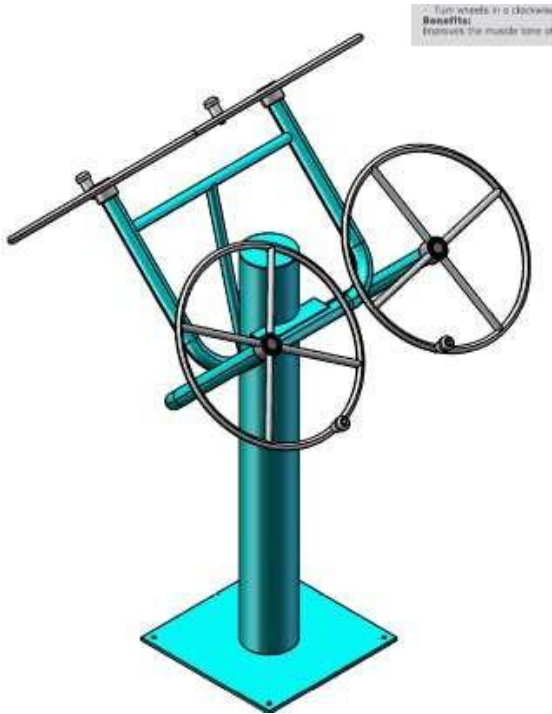

Item 6: Twin push chair

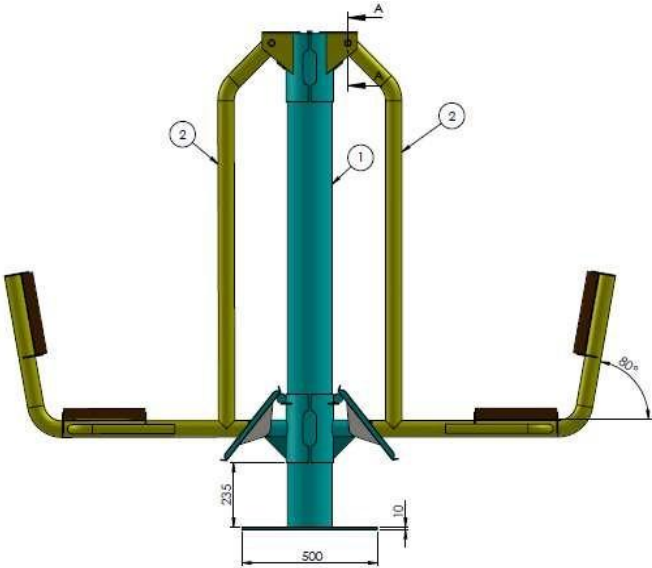

Item 7: Twin pull up chair

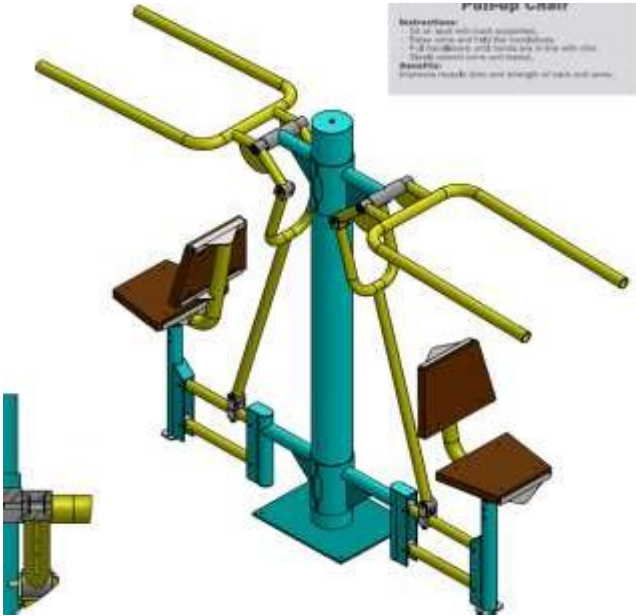

Item 8: Twin side twister

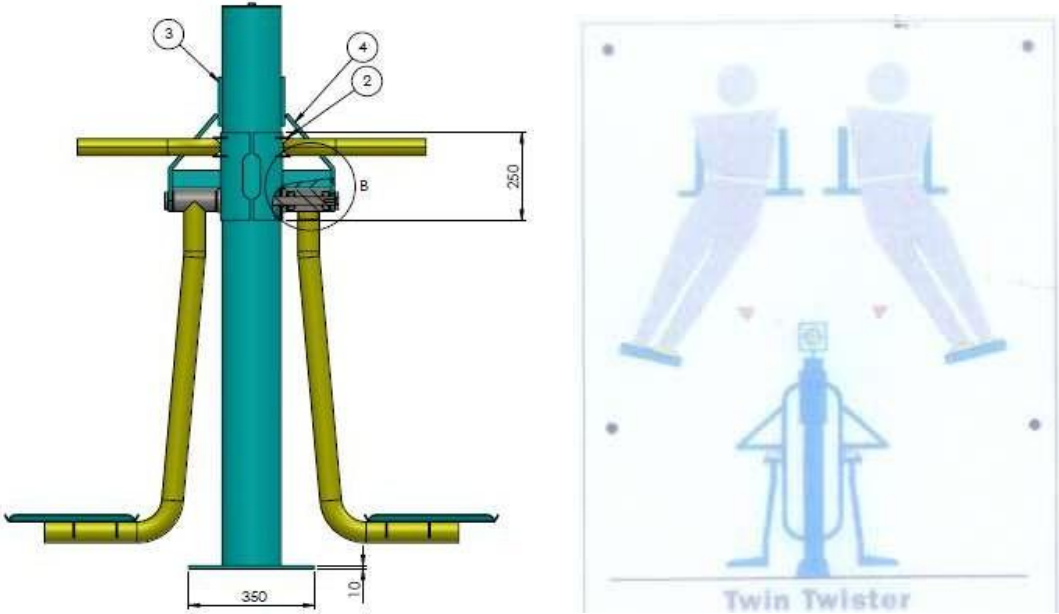

Item 9: Bicycle



Item 10: Elliptical Cross Trainer



Item 11: Rowing



Item 12: Monkey frame

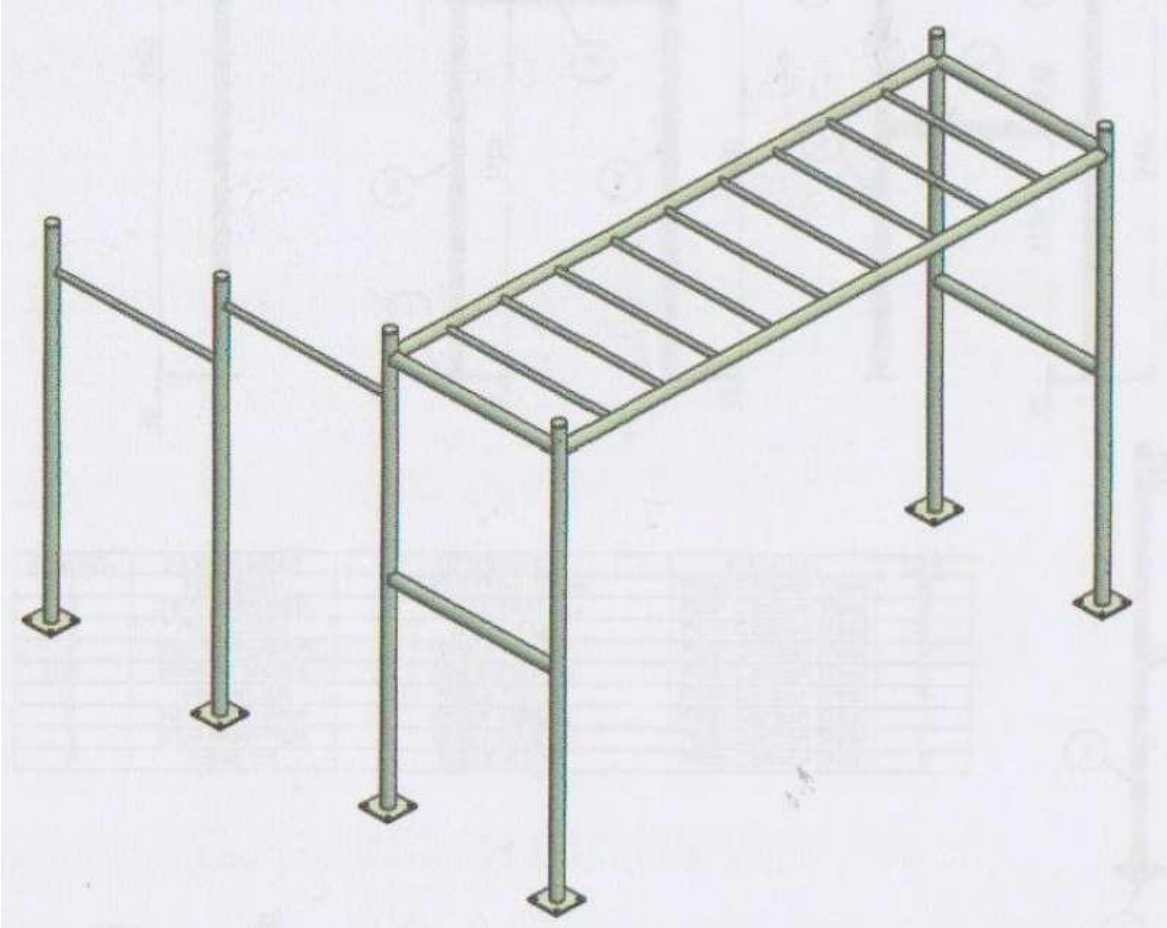

Item 13: Balancing beam



Item 14: Sit up frame



Item 15: 4 in 1 machine

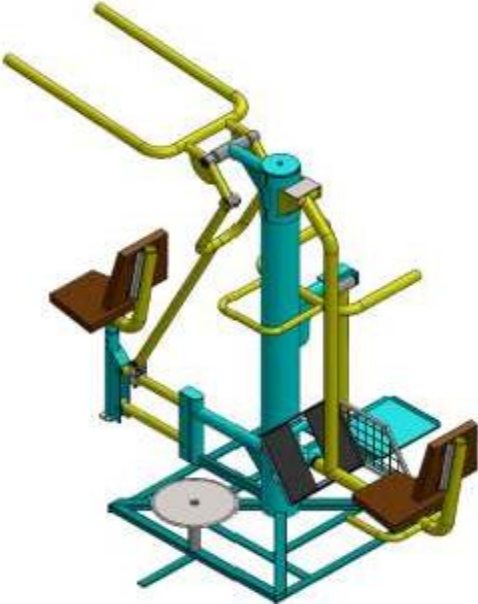

---

Signature  
Print name:  
On behalf of the tenderer (duly authorised)

---

Date

**Schedule F13.3 : Schedules**

Please complete the Schedule listed below for Evaluation Purposes –

Schedule 1: Supply of Outdoor Gym Equipment.

Schedule 2: Installation of Outdoor Gym Equipment

Schedule 3: Repairing Outdoor Gym Equipment

\_\_\_\_\_  
Signature  
Print name:  
On behalf of the tenderer (duly authorised)

\_\_\_\_\_  
Date

**F13.3 SCHEDULE 1: SUPPLY OF OUTDOOR GYM EQUIPMENT.**

**SCHEDULE 13.3.1 – COMPLETED PROJECTS**

**NUMBER OF YEARS EXPERIENCE IN SIMILAR WORK**

COMPANY / ORGANISATION NAME (TENDERED COMPANY)	YEAR STARTED	YEARS EXPERIENCE

**PROJECTS COMPLETED**

COMPANY / ORGANISATION NAME (WHOM SERVICES RENDERED FOR)	PROJECT NO / REFERENCE NO / PURCHASE ORDER NO / JOB COMPLETION CERTIFICATE	DETAILED PROJECT DESCRIPTION	PROJECT VALUE	CONTACT PERSON	CONTACT NUMBER / EMAIL

TENDER NO: 2G/2026/27

\_\_\_\_\_  
Signature  
Print name:  
On behalf of the tenderer (duly authorised)

\_\_\_\_\_  
Date

**F13.3 SCHEDULE 2 INSTALLATION OF OUTDOOR GYM EQUIPMENT**

**SCHEDULE 13.3.2 – COMPLETED PROJECTS**

**NUMBER OF YEARS EXPERIENCE IN SIMILAR WORK**

COMPANY / ORGANISATION NAME (TENDERED COMPANY)	YEAR STARTED	YEARS EXPERIENCE

**PROJECTS COMPLETED**

COMPANY / ORGANISATION NAME (WHOM SERVICES RENDERED FOR)	PROJECT NO / REFERENCE NO / PURCHASE ORDER NO / JOB COMPLETION CERTIFICATE	DETAILED PROJECT DESCRIPTION	PROJECT VALUE	CONTACT PERSON	CONTACT NUMBER / EMAIL

\_\_\_\_\_  
Signature  
Print name:  
On behalf of the tenderer (duly authorised)

\_\_\_\_\_  
Date

**F13.3 SCHEDULE 3 REPAIRING OF OUTDOOR GYM EQUIPMENT**

**SCHEDULE 13.3.3 – COMPLETED PROJECTS**

**NUMBER OF YEARS EXPERIENCE IN SIMILAR WORK**

COMPANY / ORGANISATION NAME (TENDERED COMPANY)	YEAR STARTED	YEARS EXPERIENCE

**PROJECTS COMPLETED**

COMPANY / ORGANISATION NAME (WHOM SERVICES RENDERED FOR)	PROJECT NO / REFERENCE NO / PURCHASE ORDER NO / JOB COMPLETION CERTIFICATE	DETAILED PROJECT DESCRIPTION	PROJECT VALUE	CONTACT PERSON	CONTACT NUMBER / EMAIL



**Schedule F13.4 : Evaluation Criteria**

Description of functionality criteria	Maximum possible score
<p>1. Demonstrated experience of the tendering entity with respect to a comparable project <b>Supplying of Outdoor Gym Equipment (See Schedule F13.1):</b></p> <p>0 projects .....0 points                      1 - 2 projects ..... 10 points                      3 - 4 projects ..... 25 points                      5 or more projects .....35 points</p>	35
<p>2. Demonstrated experience of the tendering entity with respect to a comparable project in <b>Installation of Outdoor Gym Equipment (See Schedule F13.2):</b></p> <p>0 projects .....0 points                      1 - 2 projects ..... 10 points                      3 - 4 projects ..... 25 points                      5 or more projects .....35 points</p>	35
<p>3. Demonstrated experience of the tendering entity with respect to a comparable project in <b>Repairing Outdoor Gym Equipment (See Schedule F13.3):</b></p> <p>0 projects .....0 points                      1 - 2 projects ..... 10 points                      3 - 4 projects ..... 20 points                      5 or more projects .....30 points</p>	30
<b>Maximum possible score for Functionality</b>	<b>100</b>
<b>Minimum possible score for Functionality</b>	<b>60</b>

The minimum qualifying score for functionality is [ 60 ] out of a maximum of [100].

\_\_\_\_\_  
 Signature  
 Print name:  
 On behalf of the tenderer (duly authorised)

\_\_\_\_\_  
 Date

**Schedule F13.5 : Regional Diagram**



\_\_\_\_\_  
Signature  
Print name:  
On behalf of the tenderer (duly authorised)

\_\_\_\_\_  
Date

<b>Schedule F13.6 : Region Tendering for</b>
--

Please indicate which Region you are tendering for with an X

<b>Region 1</b>	
<b>Region 2</b>	
<b>Both Regions</b>	

**NB.** Tenders are allowed to tender for both Regions but CCT will ultimately decide, as per ranking, which Tenderers will be allocated in which Region.

**CCT has the sole discretion to appoint the Suppliers/Service Providers per region as per the award methodology – Clause 2.1.5.1**

\_\_\_\_\_  
 Signature  
 Print name:  
 On behalf of the tenderer (duly authorised)

\_\_\_\_\_  
 Date

## Schedule F.14 : Appeal Application Form

**OFFICIAL RECEIPT**  
(Valid only if printed  
by official cash  
receiving machine)

**IRISITI ESESIKWENI**  
(Isemthethweni kuphela  
xa ishicilelwe  
ngumatshini wokukhupa  
irisiti osesikweni.)

**AMPTELIKE KWITANSIE**  
(Geldig alleenlik indien deur  
amptelike kontantvangs  
masjien gedruk.)

**GL DATA CAPTURE RECEIPT  
(CASHIER TO RETAIN A COPY)**

RECEIPT NO: \_\_\_\_\_

DATE: \_\_\_\_\_

SAP GL:

8 1 0 1 0 0

PROFIT CENTRE:

1 3 0 5 0 0 0 1

NAME/COMPANY NAME:

AMOUNT:

R 3 0 0 - 0 0

SERVICE DEPARTMENT DETAILS-

DEPARTMENT: LEGAL SERVICES; APPEALS UNIT

EMAIL: [MSA.Appeals@capetown.gov.za](mailto:MSA.Appeals@capetown.gov.za)

**OFFICIAL RECEIPT**  
(Valid only if printed  
by official cash  
receiving machine)

**IRISITI ESESIKWENI**  
(Isemthethweni kuphela  
xa ishicilelwe  
ngumatshini wokukhupa  
irisiti osesikweni.)

**AMPTELIKE KWITANSIE**  
(Geldig alleenlik indien deur  
amptelike kontantvangs  
masjien gedruk.)

**GL DATA CAPTURE RECEIPT  
(CASHIER TO RETAIN A COPY)**

RECEIPT NO: \_\_\_\_\_

DATE: \_\_\_\_\_

SAP GL:

8 1 0 1 0 0

PROFIT CENTRE:

1 3 0 5 0 0 0 1

NAME/COMPANY NAME:

AMOUNT:

R 3 0 0 - 0 0

SERVICE DEPARTMENT DETAILS-

DEPARTMENT: LEGAL SERVICES; APPEALS UNIT

EMAIL: [MSA.Appeals@capetown.gov.za](mailto:MSA.Appeals@capetown.gov.za)