

Title: **DISTRIBUTION CLASS METAL  
OXIDE SURGE ARRESTERS  
WITHOUT SPARK GAPS  
SPECIFICATION**

Unique Identifier: **240-56062768**

Alternative Reference  
Number: **34-417**

Area of Applicability: **Engineering**

Documentation Type: **Standard**

Revision: **2**

Total Pages: **46**

Next Review Date: **February 2030**

Disclosure  
Classification: **Controlled Disclosure**

**Compiled by**



**Shabnum Behari**  
**Senior Engineer –**  
**Standards Implementation**

Date: 2025/01/31

**Approved by**



**Vuyani Masuku**  
**Chief Engineer – T&E**

Date: 31/01/2025

**Authorized by**

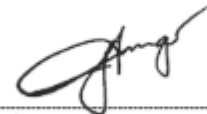

**Mfundu Songo**  
**Senior Manager – T&E**

Date: 31 January 2025

**Supported by SCOT/SC**

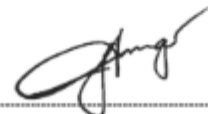

**Mfundu Songo**  
**Dx SCOT Chairperson**

Date: 31 January 2025

## Content

	Page
1. Introduction .....	4
2. Supporting clauses .....	4
2.1 Scope .....	4
2.1.1 Purpose .....	4
2.1.2 Applicability .....	4
2.2 Normative/informative references .....	4
2.2.1 Normative .....	4
2.2.2 Informative .....	4
2.3 Definitions .....	4
2.3.1 General .....	4
2.3.2 Disclosure classification .....	4
2.4 Abbreviations .....	5
2.5 Roles and responsibilities .....	5
2.6 Process for monitoring .....	5
2.7 Related/supporting documents .....	5
3. Requirements .....	5
3.1 Operating Conditions .....	5
3.2 General .....	5
3.3 Ratings .....	6
3.4 Arrester housing .....	6
3.5 Mounting .....	7
3.6 Terminals .....	7
3.7 Ground leads .....	7
3.8 Ground lead disconnecter .....	7
3.9 Documentation .....	8
3.9.1 Drawings .....	8
3.9.2 Characteristic curves .....	8
4. Testing .....	8
4.1 General .....	8
4.2 Type tests .....	9
4.2.1 Insulation withstand tests on the arrester housing .....	9
4.2.2 Insulation wet withstand test on insulated mounting bracket .....	9
4.2.3 Residual voltage test .....	9
4.2.4 Long duration current impulse withstand test .....	9
4.2.5 Operating duty tests .....	9
4.2.6 Power frequency voltage versus time characteristic .....	9
4.2.7 Short-circuit test .....	9
4.2.8 Internal partial discharge test .....	9
4.2.9 Water immersion test .....	9
4.2.10 Weather ageing and pollution performance test .....	9
4.2.11 Tests on ground lead disconnecter .....	10
4.3 Routine tests .....	11
4.3.1 Measure reference voltage (Uref) .....	11
4.3.2 Residual voltage test .....	11

**ESKOM COPYRIGHT PROTECTED**

---

4.3.3	Internal partial discharge test.....	11
4.3.4	Leakage check.....	11
5.	Marking, assembly and packaging.....	11
5.1	Marking.....	11
5.2	Assembly and packaging.....	12
6.	Authorization.....	12
7.	Revisions.....	13
8.	Development team.....	13
9.	Acknowledgements.....	13
	Annex A – Drawings.....	14
	Annex B - Technical schedules A & B.....	18

**Figures**

Figure A.1:	- Physical dimensions of distribution class arresters.....	15
Figure A.2:	- Main terminal, minimum conductor clamping arrangement.....	16
Figure A.3:	- Details of surge arrester bracket supplied with transformer.....	16
Figure A.4:	- Mounting assembly.....	17

**Tables**

Table 1:	Main arrester parameters.....	6
Table 2:	Minimum creepage requirements for Inland and Coastal applications.....	6
Table 3:	Insulation levels.....	7

## **1. Introduction**

This document consists of technical requirements for Distribution Class metal oxide surge arresters without spark gaps to be supplied to Eskom.

## **2. Supporting clauses**

### **2.1 Scope**

This specification sets out requirements for the manufacture, testing, supply and delivery of polymer distribution class, non-linear metal-oxide surge arresters without spark-gaps for installation on 11 kV, 22 kV, 33 kV and 19 kV SWER distribution systems.

#### **2.1.1 Purpose**

None

#### **2.1.2 Applicability**

This document shall apply throughout Eskom Holdings Limited Divisions.

## **2.2 Normative/informative references**

Parties using this document shall apply the most recent edition of the documents listed in the following paragraphs.

### **2.2.1 Normative**

- [1] ISO 9001 Quality Management Systems.
- [2] IEC 60099-4, Surge arresters Part 4: Metal-oxide surge arresters without gaps for a.c. systems.
- [3] IEC 60815-3, Guide for the selection of insulators in respect of polluted conditions. Polymer insulators for ac systems.
- [4] ISO/IEC 17025, General requirements for the competence of testing and calibration laboratories
- [5] 34-215, KIPTS natural ageing and pollution performance test procedure for outdoor insulator products. Section 3 - Particular requirements for surge arresters.
- [6] SANS 121, Hot-dip galvanized coatings on fabricated iron and steel articles – Specifications and test methods.
- [7] 240-170000774, INTERIM Insulation pollution standards required in PLACE of KIPTS.
- [8] 240-171000134, Issuing of Insulation Test Certificates Until KIPTS Is Operational

### **2.2.2 Informative**

None

## **2.3 Definitions**

### **2.3.1 General**

The definitions as contained in IEC60099 apply to this specification.

### **2.3.2 Disclosure classification**

**Controlled disclosure:** controlled disclosure to external parties (either enforced by law, or discretionary).

**ESKOM COPYRIGHT PROTECTED**

## 2.4 Abbreviations

Abbreviation	Description
A	Ampere
GLD	Ground Lead Disconnecter
HVH	Heavy to Very Heavy
kA	kilo- Ampere
kV	kilo-Volt
LM	Light to Medium
MCOV	Maximum Continues Operating Voltage
GLD	Ground Lead Disconnecter
SCD	Specific Creepage Distance
USCD	Unified Specific Creepage Distance

## 2.5 Roles and responsibilities

Not applicable

## 2.6 Process for monitoring

Not applicable

## 2.7 Related/supporting documents

Not applicable

## 3. Requirements

### 3.1 Operating Conditions

The surge arresters shall be able to operate under the conditions as stipulated in Schedule A in the annexures.

### 3.2 General

- 3.2.1 The Schedule A in the annexures details Eskom's requirements. The Supplier shall complete the Schedule B in full. The completed Schedule B, with the respective supporting documentation, will form the basis of evaluation of any issued tender.
- 3.2.2 The physical dimensions of arresters shall be within the limits specified in A.1.
- 3.2.3 Internal components shall be dry at the time of assembly and arresters shall be permanently sealed.
- 3.2.4 If elastomer gaskets or seals are used, precautions shall be taken to ensure adequate compression and that such gaskets or seals do not deteriorate in service as a result of exposure to the environment or electrical stresses.
- 3.2.5 All ferrous, non-current carrying components exposed to the atmosphere shall be hot-dip galvanized in accordance with SANS 121.
- 3.2.6 If dissimilar metals are used for the arrester terminals and conductor clamping arrangements, proof shall be provided of the galvanic compatibility of these materials.
- 3.2.7 Arresters shall withstand short-circuit currents without violent shattering and shall have the ability to self-extinguish any fire caused by the arc.

**ESKOM COPYRIGHT PROTECTED**

- 3.2.8** Any design changes shall be verified by testing and shall be subject to Eskom's written approval.
- 3.2.9** One sample per design, equipped as for service, shall be available for inspection at the premises of the supplier.
- 3.2.10** A unique product code shall be assigned per arrester rating. The product codes shall also distinguish between arresters intended for inland or coastal applications.

### 3.3 Ratings

The main arrester parameters are specified in 1.

**Table 1: Main arrester parameters**

1	2	3	4	5	6	7	8
System parameters				Specified arrester parameters			
Un	Um	BIL	Earthing	MCOV (min)	① U <sub>res</sub> (max)	I	Class
11 kV	12 kV	95 kV	non-effective	10 kV	40 kV	10 kA	1
22 kV	24 kV	150 kV	non-effective	19.5 kV	80 kV	10 kA	1
33 kV	36 kV	200 kV	non-effective	29 kV	120 kV	10 kA	1
② 33 kV	36 kV	200 kV	effective	23.5 kV	100 kV	10 kA	1

NOTES:  
 ① - U<sub>res</sub> at 10 kA for a 8/20 μs      ② - 19 kV SWER (phase-to-ground)

### 3.4 Arrester housing

- 3.4.1** The arresters housing shall consist of silicone based polymer. Arresters with ceramic housings are not acceptable.
- 3.4.2** The Specific Creepage Distance (SCD) of the arrester housing shall be in accordance with 2.

**Table 2: Minimum creepage requirements for Inland and Coastal applications**

1	2	3
Application	Inland	Coastal & Industrial
Pollution level	Light to Medium (LM)	Heavy to Very Heavy (HVH)
Specific Creepage Distance (SCD)	20 mm/kV	31 mm/kV

NOTE 1: Specific Creepage Distance = Creepage distance [mm] / U<sub>m</sub> [kV]  
 NOTE 2: SCD is specified and not USCD.

- 3.4.3** The arrester housing profile characteristics shall comply with the guidelines of IEC 60815-3.
- 3.4.4** The rated power frequency withstand voltage of the surge arrester housing shall be as specified in 3.

Table 3: Insulation levels

1	2
Nominal system voltage (Un)	Power frequency wet withstand
11 kV	28 kV
22 kV	50 kV
33 kV	70 kV

### 3.5 Mounting

3.5.1 Arresters shall be supplied with an insulated mounting arm for direct attachment onto the arrester mounting bracket provided on auxiliary equipment. Details of the bracket provided on auxiliary equipment are shown in A.3.

3.5.2 The insulated mounting arm shall have a mounting hole of 14 mm diameter and a minimum length (C) of 130 mm, but less than 200mm, see A.1.

3.5.3 The mounting arm shall be supplied with a M12 mounting bolt, nut, serrated washer and three flat washers. The M12 mounting bolt shall have a minimum length of 50 mm.

3.5.4 The mounting arm shall be insulated to ensure that the arrester shall pass a wet power frequency withstand test as specified in clause 4.2.2 of this document.

### 3.6 Terminals

3.6.1 On arresters equipped for service there shall be no visible permanent deformation of the terminals of the arrester when a perpendicular force of 100N is applied for 1 min to the tip of the terminal.

3.6.2 A bolted connector shall be provided on the line terminal, that can accommodate compression lugs.

3.6.3 The bolted connector shall be suitable for the standard conductor of type and dimension as specified in schedule A.

3.6.4 The bolted connector shall be such that all the strands of the conductor are positively captured, ensuring maximum contact surface between the conductor and the terminal. A.2 illustrates the minimum acceptable arrangement.

### 3.7 Ground leads

3.7.1 Arresters shall be supplied with flexible ground leads attached to the earth terminal. Braided ground leads are preferred.

3.7.2 The flexibility of the ground leads shall be such as to allow the GLD to operate correctly, isolating the arrester permanently from the ground lead.

3.7.3 Ground leads shall be bare. Insulated or covered leads are not acceptable, because the coverings tend to become hard, hampering the GLD operation.

3.7.4 Ground leads shall be a minimum of 300 mm long and shall have a current carrying capability equal to or greater than that of 16 mm<sup>2</sup> copper conductor.

3.7.5 A lug shall be provided on the free end of the flexible ground lead which can accommodate a M12 bolt.

### 3.8 Ground lead disconnecter

3.8.1 A disconnecting device shall be provided in accordance with IEC 60099-4. In the event of arrester failure the ground lead disconnecter (GLD) shall disconnect the earth tail in order to isolate the arrester electrically from the system and to give a visible indication of the failure.

**3.8.2** The GLD is required to only operate once the arrester failed. The GLD's withstand capability must therefore correlate with the withstand capability of the arrester for any impulse wave shape, even though the withstand capability of the GLD is only tested at a limited number of specified impulse wave shapes.

**3.8.3** In addition to the requirements of IEC 60099-4, the GLD shall be capable of clearing a current of 5 ampere (r.m.s. value) within 3 seconds. The test in clause 4.2.11.1 is specified to confirm compliance with this requirement.

**3.8.4** The GLD shall also be capable of withstanding two consecutive 30/80 current impulses with a peak value of 30 kA. The test in clause 4.2.11.4 is specified to confirm compliance with this requirement.

**3.8.5** In GLD designs which incorporate electronic circuit resistors in parallel to a spark gap the use of carbon composition resistors are preferred. The test in clause 4.2.11.5 simulates typical conditions which the device will be subjected to during its service life.

**3.8.6** The external housing of the GLD shall be UV stable and precautions shall be taken to ensure that the GLD do not deteriorate in service as a result of exposure to the environment.

**3.8.7** GLDs shall be permanently sealed to prevent moisture ingress. The test in clause 4.2.11.6 is specified to confirm compliance with this requirement.

**3.8.8** The GLD shall be suitably robust to withstand the mechanical shocks that can be expected during transport and installation. The operating characteristics of the GLD shall not be affected by the torque that is applied on the earth terminal when installing the flexible earth lead.

## **3.9 Documentation**

### **3.9.1 Drawings**

Drawings shall be submitted that clearly indicate the following detail per item:

- a) Dimensions A, B and C as specified in A.1.
- b) Mounting details
- c) Line terminal and ground terminal.
- d) A drawing indicating the position of the arrester markings and the detail of the markings that are provided on the rating plate.
- e) GLD constructions, detailing all internal components

### **3.9.2 Characteristic curves**

The following characteristic curves shall be submitted per item:

- a) V-I characteristic curve, AC and DC.
- b) Temporary overvoltage withstand capability curve in per unit of MCOV, with and without prior duty.

**Note:** These curves shall be submitted as drawings that contain the manufacturers name, logo and a unique drawing number. Curves submitted as part of a test report and/or data sheet are not acceptable.

## **4. Testing**

### **4.1 General**

**4.1.1** Type testing shall be conducted by an accredited testing laboratory as defined in IEC17025.

**4.1.2** Type and routine tests on arresters or pro-rated sections, identical to those offered in technical schedule B of an enquiry document, shall be conducted in accordance with IEC 60099-4.

**4.1.3** Single copies of type test reports, in English, shall be submitted with a tender. If all the required type test reports are not submitted the tender will be rated incomplete and shall not be considered.

**4.1.4** Type test reports shall contain the complete range of tests required, with the tests appropriately labelled and testing methodology fully described. Eskom reserves the right to demand test reports from an accredited testing laboratory. An accredited testing laboratory is defined as a laboratory that holds valid certification issued by ILAC (International Laboratory Accreditation Corporation) or one of its members as per IEC17025.

**4.1.5** Eskom reserves the right to appoint a representative to inspect the arresters at any stage of manufacture and to witness and sanction any tests.

## **4.2 Type tests**

The following type tests shall be performed in accordance with IEC60099-4:

### **4.2.1 Insulation withstand tests on the arrester housing**

The tests shall be conducted in accordance with IEC60099-4, clause 10.8.2.

### **4.2.2 Insulation wet withstand test on insulated mounting bracket**

In addition to the requirements of IEC 60099-4, all arresters shall have a 10 s power frequency wet withstand of 1,5 x MCOV, applied between the earth terminal and the mounting bolt in the insulated mounting arm. The test protocol shall conform to IEC60060-1.

### **4.2.3 Residual voltage test**

The tests shall be conducted in accordance with IEC60099-4, clause 10.8.3

### **4.2.4 Long duration current impulse withstand test**

The tests shall be conducted in accordance with IEC60099-4, clause 10.8.4

### **4.2.5 Operating duty tests**

The tests shall be conducted in accordance with IEC60099-4, clause 10.8.5

### **4.2.6 Power frequency voltage versus time characteristic**

### **4.2.7 Short-circuit test**

The tests shall be conducted in accordance with IEC60099-4, clause 10.8.7

### **4.2.8 Internal partial discharge test**

The tests shall be conducted in accordance with IEC60099-4, clause 10.8.8

### **4.2.9 Water immersion test**

The tests shall be conducted in accordance with IEC60099-4, clause 10.8.9.3.2

### **4.2.10 Weather ageing and pollution performance test**

Arresters shall be tested in accordance with the KIPTS natural ageing and pollution performance test procedure for outdoor insulator products, Section 3 – Particular requirements for surge arresters, 34-215.

Alternatively, testing and evidence of testing as per 240-170000774 [INTERIM Insulation pollution standards required in PLACE of KIPTS] and 240-171000134 [Issuing of Insulation Test Certificates Until KIPTS Is Operational] will be accepted.

#### 4.2.11 Tests on ground lead disconnecter

The tests shall be conducted in accordance with IEC60099-4, clause 8.6 and include the following;

##### 4.2.11.1 Long duration current impulse withstand test

In addition to the specified test procedure of IEC 60099-4, clause 8.6.2.1, the ohmic resistance of each GLD, measured across its terminals, shall be recorded before and after the test.

In order to ensure that the GLD is still in a working condition after being subjected to the long duration current impulse withstand test the operating time shall be obtained for a symmetrically initiated current level of 5 A r.m.s.  $\pm 5\%$ .

The GLD has passed the test if on all three samples:

- the GLD withstood the impulses without operating or showing any visible signs of damage;
- the GLD resistance measured before and after the test has not changed by more than 5 % and
- the operating time of the GLD at 5 A is less than 3 s.

##### 4.2.11.2 Operating duty test

In addition to the specified test procedure of IEC 60099-4, clause 8.6.2.2, the ohmic resistance of each GLD, measured across its terminals, shall be recorded before and after the test.

In order to ensure that the GLD is still in a working condition after being subjected to the operating duty test the operating time shall be obtained for a symmetrically initiated current level of 5 A r.m.s.  $\pm 5\%$ .

The GLD has passed the test if on all three samples:

- the GLD withstood the impulses without operating or showing any visible signs of damage;
- the GLD resistance measured before and after the test has not changed by more than 5 % and
- the operating time of the GLD at 5 A is less than 3 s.

##### 4.2.11.3 Time versus current curve test

In addition to the requirements of IEC 60099-4, clause 8.6.3, the operating time shall also be obtained for a symmetrically initiated current level of 5 A r.m.s.  $\pm 5\%$ .

A time versus current curve, plotting the measured r.m.s. value of the current through the GLD versus the measured duration to clear the current for the four specified current levels, shall be submitted.

##### 4.2.11.4 High lightning duty current impulse withstand test

The tests shall be conducted in accordance with IEC60099-4, clause 8.5.4

##### 4.2.11.5 Repetitive surge withstand ability test

GLDs shall be subjected to a thousand consecutive voltage impulses. The amplitude of the impulses shall exceed the spark over value of the GLD's internal gap by 120%. The impulses shall have virtual front time of 5  $\mu$ s to 10  $\mu$ s, the tail time shall be long enough to ensure that sparkover occur across the

GLD's internal gap. The source impedance of the impulse generator shall be less than 100 ohm and also 5 times smaller than the value of the GLDs internal resistor. The thousand impulses shall be applied consecutively with a 50 s to 60 s interval between impulses.

This test should be conducted on the GLD only, i.e. not connected to the arrester.

The ohmic resistance of each GLD, measured across its terminals, shall be recorded before and after the application of the impulses.

In order to ensure that the GLD is still in a working condition after being subjected to the repetitive surge withstand test the operating time shall be obtained for a symmetrically initiated current level of 5 A r.m.s.  $\pm 5$  %.

The GLD has passed the test if on all three samples:

- the GLD withstood the impulses without operating or showing any visible signs of damage;
- the GLD resistance measured before and after the test has not changed by more than 5 % and
- the operating time of the GLD at 5 A is the operating time of the GLD at 5 A is less than 3 s.

#### **4.2.11.6 Thermal pre-conditioning and water immersion test**

The thermal pre-conditioning and water immersion tests shall be conducted in accordance to IEC60099 clauses **10.8.9.3.1.3** and clause 10.9.3.1.2, respectively.

#### **4.2.11.7 Mechanical test(s)**

Test not yet established. The aim of the mechanical tests are to confirm that the GLD is suitably robust to withstand the mechanical shocks that can be expected during transport and installation and that the operating characteristics of the GLD are not affected by the torque that is applied on the earth terminal when installing the flexible earth lead.

Submit details of mechanical tests that have been conducted on the GLD.

### **4.3 Routine tests**

The following routine tests shall be conducted in accordance with IEC60099-4;

#### **4.3.1 Measure reference voltage ( $U_{ref}$ )**

The test shall be conducted in accordance with IEC60099-4, clause 9.1.a.

#### **4.3.2 Residual voltage test**

The test shall be conducted in accordance with IEC60099-4, clause 9.1.b.

#### **4.3.3 Internal partial discharge test**

The tests shall be conducted in accordance with IEC60099-4, clause 9.1.c.

#### **4.3.4 Leakage check**

The tests shall be conducted in accordance with IEC60099-4, clause 9.1.d.

## **5. Marking, assembly and packaging**

### **5.1 Marking**

The arrester shall contain the following indelible markings:

- a) manufacturer's name and trademark;
- b) product code;
- c) year of manufacture;
- d) maximum continuous operating voltage r.m.s, MCOV ( $U_c$ );
- e) rated voltage;
- f) nominal lightning discharge current;

**ESKOM COPYRIGHT PROTECTED**

g) In addition to the above markings, the GLD's product code shall be indicated on the GLD.

## **5.2 Assembly and packaging**

**5.2.1** Each arrester shall be fully assembled with the mounting bracket, GLD, flexible earth lead, line terminal hardware and mounting bolt hardware in place, ready for service as indicated in A.4.

**5.2.2** The fully assembled arresters shall be individually packed.

**5.2.3** A mounting assembly drawing, showing the detail of A.4 as a minimum, shall be supplied with each arrester.

**5.2.4** The packaging shall be such as to protect the arrester and its components against corrosion and damage during normal handling, transportation and storage.

**5.2.5** Marking of packaging shall be such as to permit easy identification of the components without their removal from the packing.

**5.2.6** Each container shall bear the following information on the outside of the container:

**5.2.6.1** product description;

**5.2.6.2** product code or part number;

**5.2.6.3** name of manufacturer and contact details;

**5.2.6.4** number of components of each type in the container;

**5.2.6.5** address of the destination;

**5.2.6.6** Eskom's purchase order number;

**5.2.6.7** Eskom's material SAP number(s).

**5.2.7** If the product is supplied by a third party supplier (e.g. importers, agents, etc.) the container shall also bear the following information on the outside of the container:

**5.2.7.1** name of the supplier;

**5.2.7.2** contact details of the supplier.

## **6. Authorization**

This document has been seen and accepted by:

<b>Name and surname</b>	<b>Designation</b>
Kevin Kleinhans	Chief Engineer - Insulation
Willem Dirkse van Schalkwyk	Chief Engineer North West OU
Chris Van Der Merwe	Corporate Consultant
Hendri Geldenhuys	Corporate Consultant
Mohammed Khan	Senior Engineer KZN OU
Rieghard Vermaak	Field Services Engineer West OU
Thavi Govender	Chief Engineer - Insulation

## 7. Revisions

Date	Rev.	Compiler	Remarks
Feb 2025	2	S Behari	<ul style="list-style-type: none"><li>Updated Normative references to include items 5 and 6</li><li>Fixed all reference errors</li><li>Updated clause 4.2.10 to reference latest EIs.</li></ul>
May 2014	1	F Witbooi	<ul style="list-style-type: none"><li>Formatting of specification to conform to new document standard.</li><li>Added references to specific IEC clauses</li><li>Minor text changes and corrections</li></ul>

## 8. Development team

The following people were involved in the development of this document:

- F Witbooi
- Thavi Govender
- Kevin Kleinhans
- S Behari (update to rev 2)
- Vuyani Masuku (update to rev 2)

## 9. Acknowledgements

Not applicable

## Annex A – Drawings

A.1

A.2

A.3

A.4

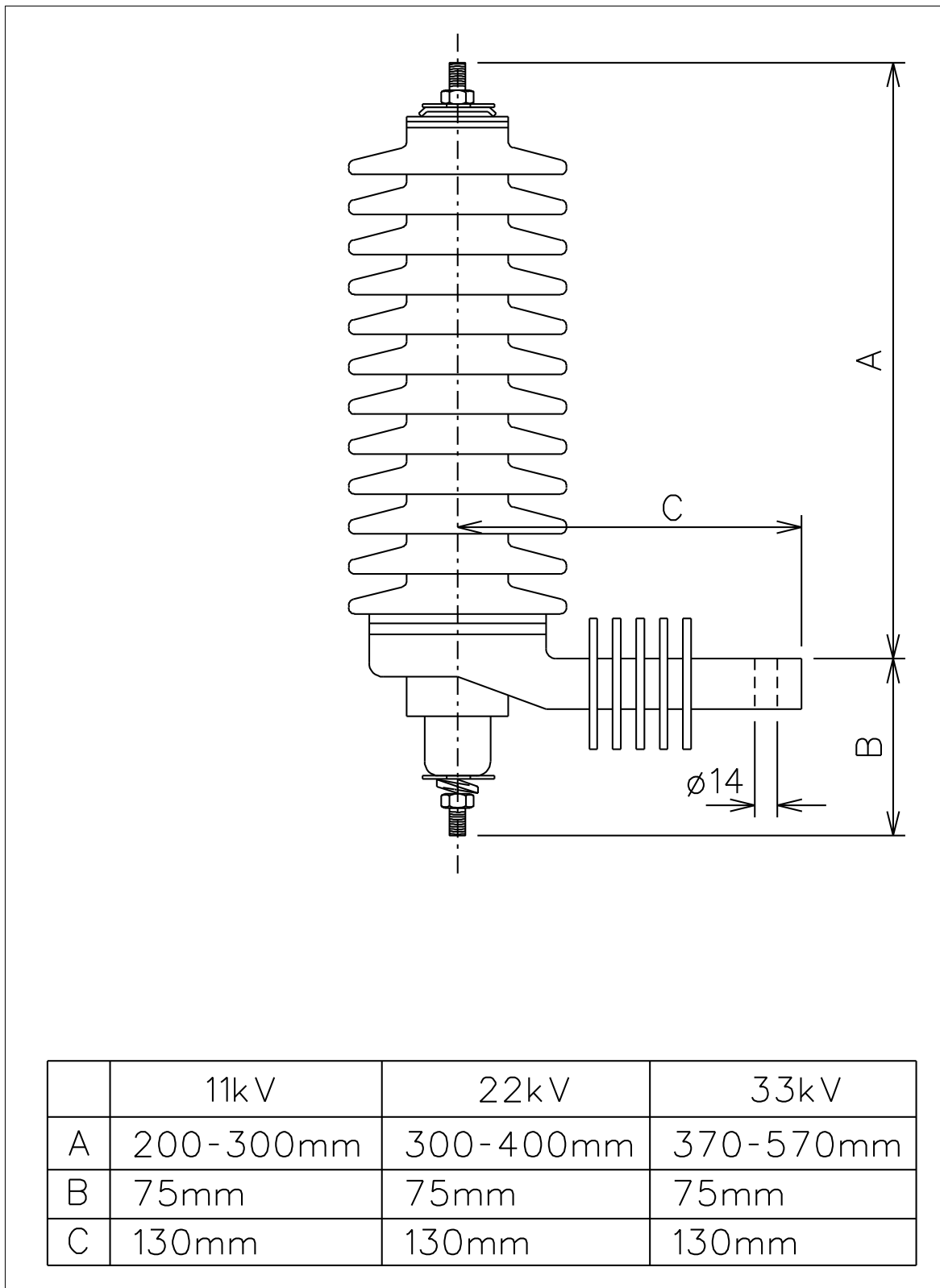

Figure A.1: - Physical dimensions of distribution class arresters

**ESKOM COPYRIGHT PROTECTED**

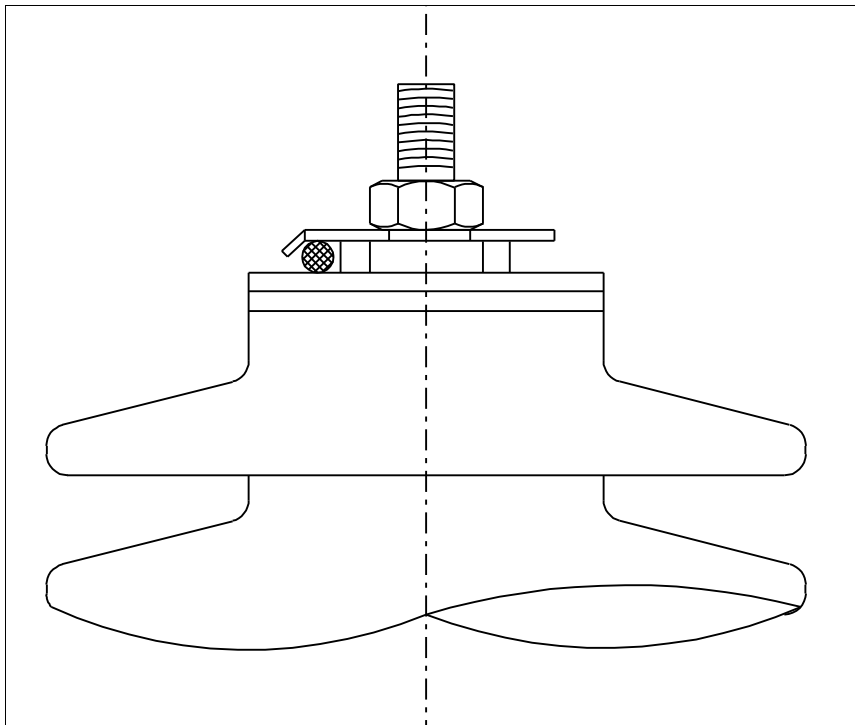

Figure A.2: - Main terminal, minimum conductor clamping arrangement

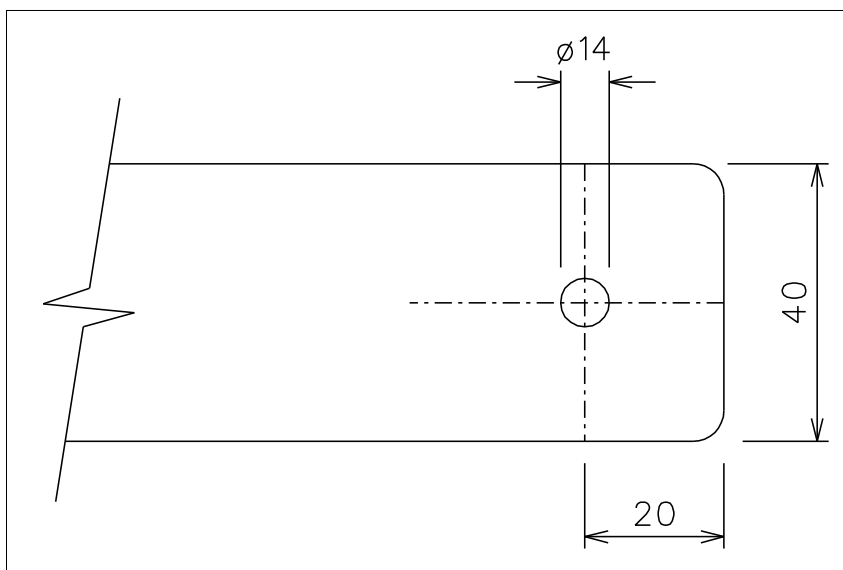

Figure A.3: - Details of surge arrester bracket supplied with transformer

**ESKOM COPYRIGHT PROTECTED**

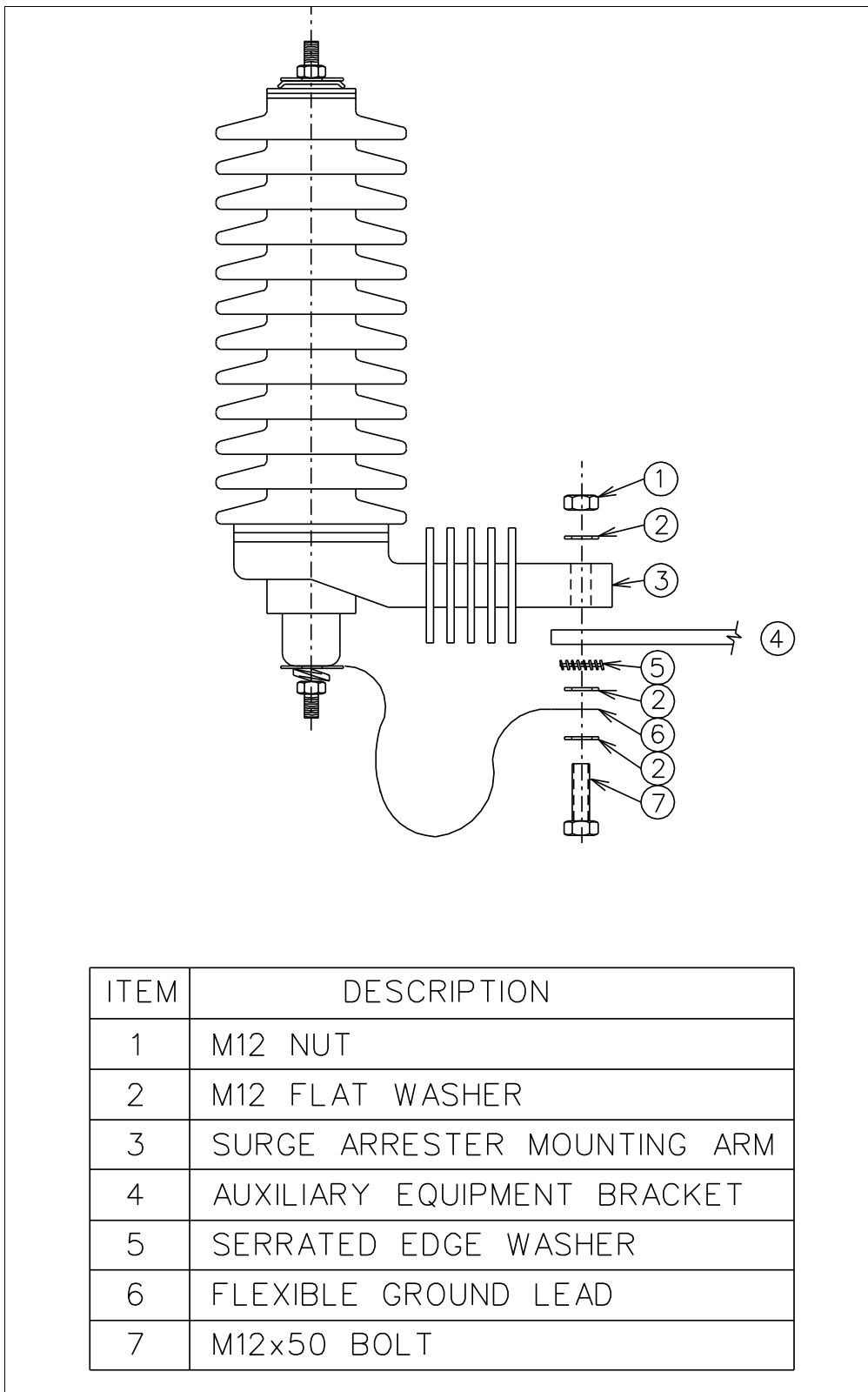

Figure A.4: - Mounting assembly

**ESKOM COPYRIGHT PROTECTED**

**Annex B - Technical schedules A & B**

	<b>Title</b>
Schedule 1	Distribution class surge arresters for 11 kV systems Item 1 – Inland application and Item 2 – Coastal application
Schedule 2	Distribution class surge arresters for 22 kV systems Item 3 – Inland application and Item 4 – Coastal application
Schedule 3	Distribution class surge arresters for 33 kV systems Item 5 – Inland application and Item 6 – Coastal application
Schedule 4	Distribution class surge arresters for 19 kV SWER systems Item 7 – Inland application and Item 8 – Coastal application

**Schedule 1 Distribution class surge arresters for 11 kV systems Item 1 – Inland application and Item 2 – Coastal application**

Schedule A: Purchaser's specific requirements

Schedule B: Particulars of equipment to be supplied

Sub clause	Description	Schedule A	Schedule B
	<ul style="list-style-type: none"> <li><b>Surge arrester identification</b></li> </ul>		
	a) Supplier	xxxxxxxxx	
	b) Manufacturer	xxxxxxxxx	
	c) MOV block manufacturer	xxxxxxxxx	
	d) Product code: Item 1 (Inland)	xxxxxxxxx	
	Item 2 (Coastal)	xxxxxxxxx	
3.1	<ul style="list-style-type: none"> <li><b>Operating conditions</b></li> </ul>		
	a) Altitude	m	up to 1800
	b) Average humidity	%	30 to 90
	c) Minimum ambient temperature	°C	-10
	Maximum ambient temperature	°C	40
	Maximum diurnal variation	°C	30
	d) Intensity of solar radiation	kW/m <sup>2</sup>	1,1
	e) IEC pollution level: Item 1 (Inland)	mm/kV	20
	Item 2 (Coastal)	mm/kV	31
	f) Lightning activity	High	xxxxxxxxxxx
	g) System earthing	Non-effective	xxxxxxxxxxx
	h) System configuration	3-phase, 3-wire	xxxxxxxxxxx
	i) Nominal system voltage ( $U_n$ )	kV	11
	j) Maximum system voltage ( $U_m$ )	kV	12
	k) Supply frequency	Hz	50
	l) BIL of equipment to be protected	kV peak	95
3.3	<ul style="list-style-type: none"> <li><b>Electrical characteristics of arrester</b></li> </ul>		
	a) Arrester classification		Distribution class
	b) IEC line discharge class		1
	c) Nominal lightning discharge current (8/20 $\mu$ s)	kA	10
	d) Energy in per unit of $U_r$ , with two high current impulses (4/10, 100kA) as tested in the operating duty test	kJ/kV	xxxxxxxxx
	e) Arrester rated voltage ( $U_r$ )	kV	xxxxxxxxx
	f) MCOV ( $U_c$ )	kV	10
	g) Maximum residual voltage ( $U_{res}$ ) at 10kA (8/20 $\mu$ s)	kV	40

Sub clause	Description	Schedule A		Schedule B	
		Item 1	Item 2	Item 1	Item 2
3.4	<ul style="list-style-type: none"> <li><b>Arrester housing</b></li> </ul>				
	a) Housing material	xxxxxxx			
	b) Colour of housing	xxxxxxx			
	c) Minimum external creepage distance:	240	372		
	d) Rated power frequency withstand voltage kV	28			
3.4.3	<ul style="list-style-type: none"> <li><b>Arrester housing profile design</b></li> </ul>				
	IEC 60815 parameters:			Item 1	Item 2
	a) c	1.	2. $\geq 20$		
	b) s/p	3.	4. $\geq 0,65$		
	c) $L_d/d$	5.	6. $\leq 5$		
	d) P1 – P2	7.	8. $\geq 15$		
	e) CF	9.	10. $\leq 3,5$		
	f) PF	11.	12. $\geq 0,7$		
3.5	<ul style="list-style-type: none"> <li><b>Arrester mounting details</b></li> </ul>				
	a) Orientation		Vertical	xxxxxxx	
	b) Method of mounting		Insulated mounting arm	xxxxxxx	
	c) Diameter of mounting hole in bracket mm		14		
	d) Minimum bracket length, i.e. dimension C mm		>130		
	e) Supplied M12 x 50 mounting bolt, nut, serrated washer and three flat washers		Yes		
3.6	<ul style="list-style-type: none"> <li><b>Terminals</b></li> </ul>				
	a) Diameter of terminals mm		xxxxxxx		
	b) Material: Line terminal		xxxxxxx		
	Earth terminal		xxxxxxx		
	c) Bolted connector on line terminal shall be suitable for clamping the following conductors:				
	Material		ACSR	xxxxxxxxxxx	
	Type		Squirrel to Hare	xxxxxxxxxxx	
	Diameter mm		6 to 14		
3.7	<ul style="list-style-type: none"> <li><b>Ground leads</b></li> </ul>				
	a) Supplied flexible ground lead		Yes		
	b) Minimum length mm		300		
	c) Diameter of hole on free end mm		14		
	d) Type (e.g. flat strip, braid etc.)		xxxxxxx		
	e) Material		xxxxxxx		

Sub clause	Description	Schedule A	Schedule B
	f) Outline dimensions	xxxxxxxxxx	
3.8	<ul style="list-style-type: none"> <li><b>Ground lead disconnecter</b></li> </ul>		
	a) Product code	xxxxxxxxxx	
	b) Resistance of internal resistor $\Omega$	xxxxxxxxxx	
3.9.1	<ul style="list-style-type: none"> <li><b>Drawings to be submitted with tender</b></li> </ul>		
	Single copies of drawings shall be submitted as part of the original tender showing the following detail:		
	a) Dimensions A, B and C as specified in A.1	Reference number	
	b) Mounting details	Reference number	
	c) Line terminal and ground terminal	Reference number	
	d) Marking details	Reference number	
	e) GLD construction	Reference number	
3.9.2	<ul style="list-style-type: none"> <li><b>Arrester characteristic data required</b></li> </ul>		
	a) V-I characteristic curve, AC	Reference number	
	b) V-I characteristic curve, DC	Reference number	
	c) Temporary overvoltage withstand capability curve in per unit of MCOV, with and with-out prior duty.	Reference number	
	<ul style="list-style-type: none"> <li><b>Arrester temporary overvoltage capability, with prior duty.</b> (prior duty as defined in annex D, IEC 60099-4)</li> </ul>		
	a) Overvoltage applied for 1 s <span style="float: right;">pu of MCOV</span>	xxxxxxxxxx	
	b) Overvoltage applied for 5 s <span style="float: right;">pu of MCOV</span>	xxxxxxxxxx	
	c) Overvoltage applied for 10 s <span style="float: right;">pu of MCOV</span>	xxxxxxxxxx	
	<ul style="list-style-type: none"> <li><b>Physical dimensions of arresters</b></li> </ul>		Item 1    Item 2
	a) Dimension A <span style="float: right;">mm</span>	200 to 300	
	b) Dimension B <span style="float: right;">mm</span>	75	
	c) External flashover distance <span style="float: right;">mm</span>	xxxxxxxxxx	
	d) External diameter of arrester housing <span style="float: right;">mm</span>	xxxxxxxxxx	
	<ul style="list-style-type: none"> <li><b>MOV elements</b></li> </ul>		
	a) Diameter of elements <span style="float: right;">mm</span>	xxxxxxxxxx	_____
	b) Thickness of elements <span style="float: right;">mm</span>	xxxxxxxxxx	_____
	c) Number of elements per arrester	xxxxxxxxxx	_____

Sub clause	Description	Schedule A	Schedule B
	<ul style="list-style-type: none"> <li><b>Miscellaneous</b></li> </ul>		
	a) Total mass of assembled unit kg	xxxxxxxxxx	_____
	b) Minimum expected life of arrester at 40 °C and MCOV yrs	25	_____
	c) Sample available for inspection	Yes	_____
4.2.1	<ul style="list-style-type: none"> <li><b>Insulation withstand test</b></li> </ul>		
	a) Reference number of test report	xxxxxxxxxx	_____
	b) Lightning impulse (1,2/50µs) withstand level [(1,3/0,82) × $U_{res}$ ] kV	63.5	_____
	c) 60 s wet power frequency withstand r.m.s kV	28	_____
4.2.2	<ul style="list-style-type: none"> <li><b>Insulation withstand test on insulated mounting bracket</b></li> </ul>		
	a) Provide reference number of test report	xxxxxxxxxx	_____
	b) 10 s wet withstand from earth terminal to earthed mounting bracket [1,5 x MCOV] kV	15	_____
4.2.3	<ul style="list-style-type: none"> <li><b>Residual voltage test</b></li> </ul>		
	a) Reference number of test report	xxxxxxxxxx	_____
	b) Maximum residual voltage for a 10 kA steep current impulse (1/20µs) [4 x $U_r$ ] kV	50	_____
	c) Maximum residual voltage for a lightning current impulse (8/20µs) of magnitude:		
	5 kA kV	xxxxxxxxxx	_____
	10 kA kV	40	_____
	20 kA kV	xxxxxxxxxx	_____
4.2.4	<ul style="list-style-type: none"> <li><b>Long duration current impulse withstand test</b></li> </ul>		
	a) Reference number of test report	xxxxxxxxxx	_____
	b) Charging voltage pu of $U_r$	3,2	_____
	or		
	charging current A	xxxxxxxxxx	_____
	c) Virtual duration of peak µs	2000	
	d) Number of discharge operations	18	
	e) Number of grouped operations	6	
	f) Operations per group	3	
	g) Maximum interval between operations s	60	
	h) Interval between groups	Cool to ambient	
	i) Maximum permitted change in residual voltage after long duration current impulse withstand test %	5	
4.2.5	<ul style="list-style-type: none"> <li><b>Operating duty test</b></li> </ul>		
	a) Reference number of test report	xxxxxxxxxx	
	<b>Conditioning part 1:</b>		

Sub clause	Description		Schedule A	Schedule B
	b) 10 kA current impulse (8/20µs), energized at 1,2 x MCOV	kV	12	
	c) Number of discharge operations		20	
	d) Number of grouped operations		4	
	e) Operations per group		5	
	f) Interval between operations	s	60	
	g) Intervals between groups	min	30	
	<b>Conditioning part 2:</b>			
	h) High current impulse (4/10µs)	kA	100	
	i) Number of applications		2	
	j) Starting temperature for first impulse	°C	20	
	k) Starting temperature for second impulse	°C	60	
	<b>Conditions for power frequency test at elevated levels as in IEC 60099-4, 7.5.2:</b>			
	l) Interval between last long duration current impulse and power frequency test	ms	100	
	m) Elevated rated voltage ( $U_r^*$ ) applied for 10 s	kV	xxxxxxxxxx	
	n) Elevated continuous operating voltage ( $U_c^*$ ) applied for 30 min	kV	xxxxxxxxxx	
	o) Maximum permitted change in residual voltage after long duration current impulse withstand test	%	5	
4.2.6	• <b>Power frequency voltage versus time characteristic</b>			
	a) Reference number of test report		xxxxxxxxxx	
4.2.7	• <b>Short-circuit test</b>			
	a) Reference number of test report		xxxxxxxxxx	
	b) High current	kA r.m.s.	20	
	c) Low current	kA r.m.s.	0,6 ± 0,2	
4.2.10	• <b>Natural ageing and pollution performance test</b>			
	a) Reference number of test report		xxxxxxxxxx	
4.2.8	• <b>Internal partial discharge test</b>			
	a) Reference number of test report		xxxxxxxxxx	
	b) Power frequency voltage applied [1,05 x MCOV]	kV	10.5	
	c) Maximum partial discharge	pC	10	
4.2.9	• <b>Water Immersion test</b>			
	a) Reference number of test report		xxxxxxxxxx	
4.2.11.1	• <b>GLD long duration current impulse withstand test</b>			
	a) Provide reference number of test report		xxxxxxxxxx	
4.2.11.2	<b>27. GLD time versus current curve test</b>			

Sub clause	Description	Schedule A	Schedule B
	a) Provide reference number of test report	XXXXXXXXXX	
4.2.11.3	<b>28. GLD operating duty test</b>		
	a) Provide reference number of test report	XXXXXXXXXX	
	b) Disconnecter operating time at current levels:		
	5 A r.m.s. s	< 3	
	20 A r.m.s. s	XXXXXXXXXX	
	200 A r.m.s. s	XXXXXXXXXX	
	800 A r.m.s.	XXXXXXXXXX	
4.2.11.4	<b>• GLD high lightning duty current impulse withstand test</b>		
	a) Provide reference number of test report	XXXXXXXXXX	
4.2.11.5	<b>• GLD repetitive surge withstand ability test</b>		
	a) Provide reference number of test report	XXXXXXXXXX	
4.2.11.6	<b>• GLD water immersion test</b>		
	a) Provide reference number of test report	XXXXXXXXXX	
4.2.11.7	<b>• GLD mechanical test</b>		
	a) Provide reference number of test report	XXXXXXXXXX	

### Deviation schedule

Any deviations from this specification shall be listed below with reasons for deviation. In addition, evidence shall be provided that the proposed deviation will at least be more cost-effective than that specified by Eskom.

Item	Clause	Proposed deviation

**Schedule 2 Distribution class surge arresters for 22 kV systems Item 3 – Inland application and Item 4 – Coastal application**

Schedule A: Purchaser's specific requirements

Schedule B: Particulars of equipment to be supplied

Sub clause	Description	Schedule A	Schedule B
	• <b>Surge arrester identification</b>		
	e) Supplier	XXXXXXXXXX	
	f) Manufacturer	XXXXXXXXXX	
	g) MOV block manufacturer	XXXXXXXXXX	
	h) Product code: Item 1 (Inland)	XXXXXXXXXX	
	Item 2 (Coastal)	XXXXXXXXXX	
3.1	• <b>Operating conditions</b>		
	m) Altitude	m	up to 1800
	n) Average humidity	%	30 to 90
	o) Minimum ambient temperature	°C	-10
	Maximum ambient temperature	°C	40
	Maximum diurnal variation	°C	30
	p) Intensity of solar radiation	kW/m <sup>2</sup>	1,1
	q) IEC pollution level: Item 1 (Inland)	mm/kV	20
	Item 2 (Coastal)	mm/kV	31
	r) Lightning activity	High	XXXXXXXXXXXX
	s) System earthing	Non-effective	XXXXXXXXXXXX
	t) System configuration	3-phase, 3-wire	XXXXXXXXXXXX
	u) Nominal system voltage ( $U_n$ )	kV	22
	v) Maximum system voltage ( $U_m$ )	kV	24
	w) Supply frequency	Hz	50
	x) BIL of equipment to be protected	kV peak	150
3.3	• <b>Electrical characteristics of arrester</b>		
	h) Arrester classification		Distribution class
	i) IEC line discharge class		1
	j) Nominal lightning discharge current (8/20 $\mu$ s)	kA	10
	k) Energy in per unit of $U_r$ , with two high current impulses (4/10, 100kA) as tested in the operating duty test	kJ/kV	XXXXXXXXXX
	l) Arrester rated voltage ( $U_r$ )	kV	XXXXXXXXXX
	m) MCOV ( $U_c$ )	kV	19.5
	n) Maximum residual voltage ( $U_{res}$ ) at 10kA (8/20 $\mu$ s)	kV	80

Sub clause	Description	Schedule A		Schedule B	
		Item 1	Item 2	Item 1	Item 2
3.4	<ul style="list-style-type: none"> <li><b>Arrester housing</b></li> </ul>			Item 1	Item 2
	e) Housing material	xxxxxxxxxx			
	f) Colour of housing	xxxxxxxxxx			
	g) Minimum external creepage distance:	480	744		
	h) Rated power frequency withstand voltage kV	50			
3.4.3	<ul style="list-style-type: none"> <li><b>Arrester housing profile design</b></li> </ul>			Item 1	Item 2
	IEC 60815 parameters:				
	g) c	13.	14. $\geq 20$		
	h) s/p	15.	16. $\geq 0,65$		
	i) $L_d/d$	17.	18. $\leq 5$		
	j) P1 – P2	19.	20. $\geq 15$		
	k) CF	21.	22. $\leq 3,5$		
	l) PF	23.	24. $\geq 0,7$		
3.5	<ul style="list-style-type: none"> <li><b>Arrester mounting details</b></li> </ul>				
	f) Orientation	Vertical		xxxxxxxxxx	
	g) Method of mounting	Insulated mounting arm		xxxxxxxxxx	
	h) Diameter of mounting hole in bracket mm	14			
	i) Minimum bracket length, i.e. dimension C mm	$>130$			
	j) Supplied M12 x 50 mounting bolt, nut, serrated washer and three flat washers	Yes			
3.6	<ul style="list-style-type: none"> <li><b>Terminals</b></li> </ul>				
	d) Diameter of terminals mm	xxxxxxxxxx			
	e) Material: Line terminal	xxxxxxxxxx			
	Earth terminal	xxxxxxxxxx			
	f) Bolted connector on line terminal shall be suitable for clamping the following conductors:				
	Material	ACSR		xxxxxxxxxxxxxx	
	Type	Squirrel to Hare		xxxxxxxxxxxxxx	
	Diameter mm	6 to 14			
3.7	<ul style="list-style-type: none"> <li><b>Ground leads</b></li> </ul>				
	g) Supplied flexible ground lead	Yes			
	h) Minimum length mm	300			
	i) Diameter of hole on free end mm	14			
	j) Type (e.g. flat strip, braid etc.)	xxxxxxxxxx			
	k) Material	xxxxxxxxxx			

Sub clause	Description	Schedule A	Schedule B	
	l) Outline dimensions	xxxxxxxxxx		
3.8	<ul style="list-style-type: none"> <li><b>Ground lead disconnecter</b></li> </ul>			
	c) Product code	xxxxxxxxxx		
	d) Resistance of internal resistor $\Omega$	xxxxxxxxxx		
3.9.1	<ul style="list-style-type: none"> <li><b>Drawings to be submitted with tender</b></li> </ul>			
	Single copies of drawings shall be submitted as part of the original tender showing the following detail:			
	f) Dimensions A, B and C as specified in A.1	Reference number		
	g) Mounting details	Reference number		
	h) Line terminal and ground terminal	Reference number		
	i) Marking details	Reference number		
	j) GLD construction	Reference number		
3.9.2	<ul style="list-style-type: none"> <li><b>Arrester characteristic data required</b></li> </ul>			
	d) V-I characteristic curve, AC	Reference number		
	e) V-I characteristic curve, DC	Reference number		
	f) Temporary overvoltage withstand capability curve in per unit of MCOV, with and with-out prior duty.	Reference number		
	<ul style="list-style-type: none"> <li><b>Arrester temporary overvoltage capability, with prior duty.</b> (prior duty as defined in annex D, IEC 60099-4)</li> </ul>			
	d) Overvoltage applied for 1 s	pu of MCOV xxxxxxxxxx		
	e) Overvoltage applied for 5 s	pu of MCOV xxxxxxxxxx		
	f) Overvoltage applied for 10 s	pu of MCOV xxxxxxxxxx		
	<ul style="list-style-type: none"> <li><b>Physical dimensions of arresters</b></li> </ul>		Item 1	Item 2
	e) Dimension A	mm	300 to 400	
	f) Dimension B	mm	75	
	g) External flashover distance	mm	xxxxxxxxxx	
	h) External diameter of arrester housing	mm	xxxxxxxxxx	
	<ul style="list-style-type: none"> <li><b>MOV elements</b></li> </ul>			
	d) Diameter of elements	mm	xxxxxxxxxx	_____
	e) Thickness of elements	mm	xxxxxxxxxx	_____
	f) Number of elements per arrester		xxxxxxxxxx	_____

Sub clause	Description	Schedule A	Schedule B
	<ul style="list-style-type: none"> <li><b>Miscellaneous</b></li> </ul>		
	d) Total mass of assembled unit kg	xxxxxxxxxx	_____
	e) Minimum expected life of arrester at 40 °C and MCOV yrs	25	_____
	f) Sample available for inspection	Yes	_____
4.2.1	<ul style="list-style-type: none"> <li><b>Insulation withstand test</b></li> </ul>		
	d) Reference number of test report	xxxxxxxxxx	_____
	e) Lightning impulse (1,2/50µs) withstand level [(1,3/0,82) × $U_{res}$ ] kV	127	_____
	f) 60 s wet power frequency withstand r.m.s kV	50	_____
4.2.2	<ul style="list-style-type: none"> <li><b>Insulation withstand test on insulated mounting bracket</b></li> </ul>		
	c) Provide reference number of test report	xxxxxxxxxx	_____
	d) 10 s wet withstand from earth terminal to earthed mounting bracket [1,5 x MCOV] kV	29	_____
4.2.3	<ul style="list-style-type: none"> <li><b>Residual voltage test</b></li> </ul>		
	d) Reference number of test report	xxxxxxxxxx	_____
	e) Maximum residual voltage for a 10 kA steep current impulse (1/20µs) [4 x $U_r$ ] kV	100	_____
	f) Maximum residual voltage for a lightning current impulse (8/20µs) of magnitude:		
	5 kA kV	xxxxxxxxxx	_____
	10 kA kV	80	_____
	20 kA kV	xxxxxxxxxx	_____
4.2.4	<ul style="list-style-type: none"> <li><b>Long duration current impulse withstand test</b></li> </ul>		
	j) Reference number of test report	xxxxxxxxxx	_____
	k) Charging voltage pu of $U_r$	3,2	_____
	or		
	charging current A	xxxxxxxxxx	_____
	l) Virtual duration of peak µs	2000	
	m) Number of discharge operations	18	
	n) Number of grouped operations	6	
	o) Operations per group	3	
	p) Maximum interval between operations s	60	
	q) Interval between groups	Cool to ambient	
	r) Maximum permitted change in residual voltage after long duration current impulse withstand test %	5	
4.2.5	<ul style="list-style-type: none"> <li><b>Operating duty test</b></li> </ul>		
	p) Reference number of test report	xxxxxxxxxx	
	<b>Conditioning part 1:</b>		

Sub clause	Description		Schedule A	Schedule B
	q) 10 kA current impulse (8/20µs), energized at 1,2 x MCOV	kV	23.5	
	r) Number of discharge operations		20	
	s) Number of grouped operations		4	
	t) Operations per group		5	
	u) Interval between operations	s	60	
	v) Intervals between groups	min	30	
	<b>Conditioning part 2:</b>			
	w) High current impulse (4/10µs)	kA	100	
	x) Number of applications		2	
	y) Starting temperature for first impulse	°C	20	
	z) Starting temperature for second impulse	°C	60	
	<b>Conditions for power frequency test at elevated levels as in IEC 60099-4, 7.5.2:</b>			
	aa) Interval between last long duration current impulse and power frequency test	ms	100	
	bb) Elevated rated voltage ( $U_r^*$ ) applied for 10 s	kV	xxxxxxxxxx	
	cc) Elevated continuous operating voltage ( $U_c^*$ ) applied for 30 min	kV	xxxxxxxxxx	
	dd) Maximum permitted change in residual voltage after long duration current impulse withstand test	%	5	
4.2.6	• <b>Power frequency voltage versus time characteristic</b>			
	b) Reference number of test report		xxxxxxxxxx	
4.2.7	• <b>Short-circuit test</b>			
	d) Reference number of test report		xxxxxxxxxx	
	e) High current	kA r.m.s.	20	
	f) Low current	kA r.m.s.	0,6 ± 0,2	
4.2.10	• <b>Natural ageing and pollution performance test</b>			
	b) Reference number of test report		xxxxxxxxxx	
4.2.8	• <b>Internal partial discharge test</b>			
	d) Reference number of test report		xxxxxxxxxx	
	e) Power frequency voltage applied [1,05 x MCOV]	kV	20.5	
	f) Maximum partial discharge	pC	10	
4.2.9	• <b>Water Immersion test</b>			
	b) Reference number of test report		xxxxxxxxxx	
4.2.11.1	• <b>GLD long duration current impulse withstand test</b>			
	b) Provide reference number of test report		xxxxxxxxxx	
4.2.11.2	<b>28. GLD time versus current curve test</b>			

Sub clause	Description	Schedule A	Schedule B
	b) Provide reference number of test report	XXXXXXXXXX	
4.2.11.3	<b>29. GLD operating duty test</b>		
	c) Provide reference number of test report	XXXXXXXXXX	
	d) Disconnecter operating time at current levels:		
	5 A r.m.s. s	< 3	
	20 A r.m.s. s	XXXXXXXXXX	
	200 A r.m.s. s	XXXXXXXXXX	
	800 A r.m.s.	XXXXXXXXXX	
4.2.11.4	<b>• GLD high lightning duty current impulse withstand test</b>		
	b) Provide reference number of test report	XXXXXXXXXX	
4.2.11.5	<b>• GLD repetitive surge withstand ability test</b>		
	b) Provide reference number of test report	XXXXXXXXXX	
4.2.11.6	<b>• GLD water immersion test</b>		
	b) Provide reference number of test report	XXXXXXXXXX	
4.2.11.7	<b>• GLD mechanical test</b>		
	b) Provide reference number of test report	XXXXXXXXXX	

### Deviation schedule

Any deviations from this specification shall be listed below with reasons for deviation. In addition, evidence shall be provided that the proposed deviation will at least be more cost-effective than that specified by Eskom.

Item	Clause	Proposed deviation

**Schedule 3 Distribution class surge arresters for 33 kV systems Item 5 – Inland application and Item 6 – Coastal application**

Schedule A: Purchaser's specific requirements

Schedule B: Particulars of equipment to be supplied

Sub clause	Description	Schedule A	Schedule B
	<b>1. Surge arrester identification</b>		
	i) Supplier	xxxxxxxxxx	
	j) Manufacturer	xxxxxxxxxx	
	k) MOV block manufacturer	xxxxxxxxxx	
	l) Product code: Item 1 (Inland)	xxxxxxxxxx	
	Item 2 (Coastal)	xxxxxxxxxx	
3.1	<b>2. Operating conditions</b>		
	y) Altitude	m	up to 1800
	z) Average humidity	%	30 to 90
	aa) Minimum ambient temperature	°C	-10
	Maximum ambient temperature	°C	40
	Maximum diurnal variation	°C	30
	bb) Intensity of solar radiation	kW/m <sup>2</sup>	1,1
	cc) IEC pollution level: Item 1 (Inland)	mm/kV	20
	Item 2 (Coastal)	mm/kV	31
	dd) Lightning activity		High
	ee) System earthing		Non-effective
	ff) System configuration		3-phase, 3-wire
	gg) Nominal system voltage ( $U_n$ )	kV	33
	hh) Maximum system voltage ( $U_m$ )	kV	36
	ii) Supply frequency	Hz	50
	jj) BIL of equipment to be protected	kV peak	200
3.3	<b>• Electrical characteristics of arrester</b>		
	o) Arrester classification		Distribution class
	p) IEC line discharge class		1
	q) Nominal lightning discharge current (8/20 $\mu$ s)	kA	10
	r) Energy in per unit of $U_r$ , with two high current impulses (4/10, 100kA) as tested in the operating duty test	kJ/kV	xxxxxxxxxx
	s) Arrester rated voltage ( $U_r$ )	kV	xxxxxxxxxx
	t) MCOV ( $U_c$ )	kV	29
	u) Maximum residual voltage ( $U_{res}$ ) at 10kA (8/20 $\mu$ s)	kV	120

Sub clause	Description	Schedule A		Schedule B	
		Item 1	Item 2	Item 1	Item 2
3.4	<ul style="list-style-type: none"> <li><b>Arrester housing</b></li> </ul>			Item 1	Item 2
	i) Housing material	xxxxxxxxxx			
	j) Colour of housing	xxxxxxxxxx			
	k) Minimum external creepage distance:	720	1116		
	l) Rated power frequency withstand voltage kV	70			
3.4.3	<ul style="list-style-type: none"> <li><b>Arrester housing profile design</b></li> </ul>			Item 1	Item 2
	IEC 60815 parameters:				
	m) c	25.	26. $\geq 20$		
	n) s/p	27.	28. $\geq 0,65$		
	o) $L_d/d$	29.	30. $\leq 5$		
	p) P1 – P2	31.	32. $\geq 15$		
	q) CF	33.	34. $\leq 3,5$		
	r) PF	35.	36. $\geq 0,7$		
3.5	<ul style="list-style-type: none"> <li><b>Arrester mounting details</b></li> </ul>				
	k) Orientation	Vertical		xxxxxxxxxx	
	l) Method of mounting	Insulated mounting arm		xxxxxxxxxx	
	m) Diameter of mounting hole in bracket mm	14			
	n) Minimum bracket length, i.e. dimension C mm	$>130$			
	o) Supplied M12 x 50 mounting bolt, nut, serrated washer and three flat washers	Yes			
3.6	<ul style="list-style-type: none"> <li><b>Terminals</b></li> </ul>				
	g) Diameter of terminals mm	xxxxxxxxxx			
	h) Material: Line terminal	xxxxxxxxxx			
	Earth terminal	xxxxxxxxxx			
	i) Bolted connector on line terminal shall be suitable for clamping the following conductors:				
	Material	ACSR		xxxxxxxxxxxxxx	
	Type	Squirrel to Hare		xxxxxxxxxxxxxx	
	Diameter mm	6 to 14			
3.7	<ul style="list-style-type: none"> <li><b>Ground leads</b></li> </ul>				
	m) Supplied flexible ground lead	Yes			
	n) Minimum length mm	300			
	o) Diameter of hole on free end mm	14			
	p) Type (e.g. flat strip, braid etc.)	xxxxxxxxxx			
	q) Material	xxxxxxxxxx			

Sub clause	Description	Schedule A	Schedule B	
	r) Outline dimensions	xxxxxxxxxx		
3.8	<ul style="list-style-type: none"> <li><b>Ground lead disconnecter</b></li> </ul>			
	e) Product code	xxxxxxxxxx		
	f) Resistance of internal resistor $\Omega$	xxxxxxxxxx		
3.9.1	<ul style="list-style-type: none"> <li><b>Drawings to be submitted with tender</b></li> </ul>			
	Single copies of drawings shall be submitted as part of the original tender showing the following detail:			
	k) Dimensions A, B and C as specified in A.1	Reference number		
	l) Mounting details	Reference number		
	m) Line terminal and ground terminal	Reference number		
	n) Marking details	Reference number		
	o) GLD construction	Reference number		
3.9.2	<ul style="list-style-type: none"> <li><b>Arrester characteristic data required</b></li> </ul>			
	g) V-I characteristic curve, AC	Reference number		
	h) V-I characteristic curve, DC	Reference number		
	i) Temporary overvoltage withstand capability curve in per unit of MCOV, with and with-out prior duty.	Reference number		
	<ul style="list-style-type: none"> <li><b>Arrester temporary overvoltage capability, with prior duty.</b> (prior duty as defined in annex D, IEC 60099-4)</li> </ul>			
	g) Overvoltage applied for 1 s	pu of MCOV xxxxxxxxxx		
	h) Overvoltage applied for 5 s	pu of MCOV xxxxxxxxxx		
	i) Overvoltage applied for 10 s	pu of MCOV xxxxxxxxxx		
	<ul style="list-style-type: none"> <li><b>Physical dimensions of arresters</b></li> </ul>		Item 1	Item 2
	i) Dimension A	mm	370 to 57-	
	j) Dimension B	mm	75	
	k) External flashover distance	mm	xxxxxxxxxx	
	l) External diameter of arrester housing	mm	xxxxxxxxxx	
	<ul style="list-style-type: none"> <li><b>MOV elements</b></li> </ul>			
	g) Diameter of elements	mm	xxxxxxxxxx	_____
	h) Thickness of elements	mm	xxxxxxxxxx	_____
	i) Number of elements per arrester		xxxxxxxxxx	_____

Sub clause	Description	Schedule A	Schedule B
	<ul style="list-style-type: none"> <li><b>Miscellaneous</b></li> </ul>		
	g) Total mass of assembled unit kg	xxxxxxxxxx	_____
	h) Minimum expected life of arrester at 40 °C and MCOV yrs	25	_____
	i) Sample available for inspection	Yes	_____
4.2.1	<ul style="list-style-type: none"> <li><b>Insulation withstand test</b></li> </ul>		
	g) Reference number of test report	xxxxxxxxxx	_____
	h) Lightning impulse (1,2/50µs) withstand level [(1,3/0,82) × U <sub>res</sub> ] kV	190	_____
	i) 60 s wet power frequency withstand r.m.s kV	70	_____
4.2.2	<ul style="list-style-type: none"> <li><b>Insulation withstand test on insulated mounting bracket</b></li> </ul>		
	e) Provide reference number of test report	xxxxxxxxxx	_____
	f) 10 s wet withstand from earth terminal to earthed mounting bracket [1,5 x MCOV] kV	43.5	_____
4.2.3	<ul style="list-style-type: none"> <li><b>Residual voltage test</b></li> </ul>		
	g) Reference number of test report	xxxxxxxxxx	_____
	h) Maximum residual voltage for a 10 kA steep current impulse (1/20µs) [4 x U <sub>r</sub> ] kV	145	_____
	i) Maximum residual voltage for a lightning current impulse (8/20µs) of magnitude:		
	5 kA kV	xxxxxxxxxx	_____
	10 kA kV	120	_____
	20 kA kV	xxxxxxxxxx	_____
4.2.4	<ul style="list-style-type: none"> <li><b>Long duration current impulse withstand test</b></li> </ul>		
	s) Reference number of test report	xxxxxxxxxx	_____
	t) Charging voltage pu of U <sub>r</sub>	3,2	_____
	or		
	charging current A	xxxxxxxxxx	_____
	u) Virtual duration of peak µs	2000	
	v) Number of discharge operations	18	
	w) Number of grouped operations	6	
	x) Operations per group	3	
	y) Maximum interval between operations s	60	
	z) Interval between groups	Cool to ambient	
	aa) Maximum permitted change in residual voltage after long duration current impulse withstand test %	5	
4.2.5	<ul style="list-style-type: none"> <li><b>Operating duty test</b></li> </ul>		
	ee) Reference number of test report	xxxxxxxxxx	
	<b>Conditioning part 1:</b>		

Sub clause	Description		Schedule A	Schedule B
	ff) 10 kA current impulse (8/20 $\mu$ s), energized at 1,2 x MCOV	kV	35	
	gg) Number of discharge operations		20	
	hh) Number of grouped operations		4	
	ii) Operations per group		5	
	jj) Interval between operations	s	60	
	kk) Intervals between groups	min	30	
	<b>Conditioning part 2:</b>			
	ll) High current impulse (4/10 $\mu$ s)	kA	100	
	mm) Number of applications		2	
	nn) Starting temperature for first impulse	$^{\circ}$ C	20	
	oo) Starting temperature for second impulse	$^{\circ}$ C	60	
	<b>Conditions for power frequency test at elevated levels as in IEC 60099-4, 7.5.2:</b>			
	pp) Interval between last long duration current impulse and power frequency test	ms	100	
	qq) Elevated rated voltage ( $U_r^*$ ) applied for 10 s	kV	xxxxxxxxxx	
	rr) Elevated continuous operating voltage ( $U_c^*$ ) applied for 30 min	kV	xxxxxxxxxx	
	ss) Maximum permitted change in residual voltage after long duration current impulse withstand test	%	5	
4.2.6	<b>• Power frequency voltage versus time characteristic</b>			
	c) Reference number of test report		xxxxxxxxxx	
4.2.7	<b>• Short-circuit test</b>			
	g) Reference number of test report		xxxxxxxxxx	
	h) High current	kA r.m.s.	20	
	i) Low current	kA r.m.s.	0,6 $\pm$ 0,2	
4.2.10	<b>• Natural ageing and pollution performance test</b>			
	c) Reference number of test report		xxxxxxxxxx	
4.2.8	<b>• Internal partial discharge test</b>			
	g) Reference number of test report		xxxxxxxxxx	
	h) Power frequency voltage applied [1,05 x MCOV]	kV	30.5	
	i) Maximum partial discharge	pC	10	
4.2.9	<b>• Water Immersion test</b>			
	c) Reference number of test report		xxxxxxxxxx	
4.2.11.1	<b>• GLD long duration current impulse withstand test</b>			
	c) Provide reference number of test report		xxxxxxxxxx	
4.2.11.2	<b>29. GLD time versus current curve test</b>			

Sub clause	Description	Schedule A	Schedule B
	c) Provide reference number of test report	XXXXXXXXXX	
4.2.11.3	<b>3. GLD operating duty test</b>		
	e) Provide reference number of test report	XXXXXXXXXX	
	f) Disconnecter operating time at current levels:		
	5 A r.m.s. s	< 3	
	20 A r.m.s. s	XXXXXXXXXX	
	200 A r.m.s. s	XXXXXXXXXX	
	800 A r.m.s.	XXXXXXXXXX	
4.2.11.4	<b>• GLD high lightning duty current impulse withstand test</b>		
	c) Provide reference number of test report	XXXXXXXXXX	
4.2.11.5	<b>• GLD repetitive surge withstand ability test</b>		
	c) Provide reference number of test report	XXXXXXXXXX	
4.2.11.6	<b>• GLD water immersion test</b>		
	c) Provide reference number of test report	XXXXXXXXXX	
4.2.11.7	<b>• GLD mechanical test</b>		
	c) Provide reference number of test report	XXXXXXXXXX	

### Deviation schedule

Any deviations from this specification shall be listed below with reasons for deviation. In addition, evidence shall be provided that the proposed deviation will at least be more cost-effective than that specified by Eskom.

Item	Clause	Proposed deviation

**ESKOM COPYRIGHT PROTECTED**

**Schedule 4 Distribution class surge arresters for 19 kV SWER systems Item 7 – Inland application and Item 8 – Coastal application**

Schedule A: Purchaser's specific requirements

Schedule B: Particulars of equipment to be supplied

Sub clause	Description	Schedule A	Schedule B
	• <b>Surge arrester identification</b>		
	m) Supplier	XXXXXXXXXX	
	n) Manufacturer	XXXXXXXXXX	
	o) MOV block manufacturer	XXXXXXXXXX	
	p) Product code: Item 1 (Inland)	XXXXXXXXXX	
	Item 2 (Coastal)	XXXXXXXXXX	
3.1	• <b>Operating conditions</b>		
	kk) Altitude	m	up to 1800
	ll) Average humidity	%	30 to 90
	mm) Minimum ambient temperature	°C	-10
	Maximum ambient temperature	°C	40
	Maximum diurnal variation	°C	30
	nn) Intensity of solar radiation	kW/m <sup>2</sup>	1,1
	oo) IEC pollution level: Item 1 (Inland)	mm/kV	20
	Item 2 (Coastal)	mm/kV	31
	pp) Lightning activity		High
	qq) System earthing		Non-effective
	rr) System configuration		3-phase, 3-wire
	ss) Nominal system voltage ( $U_n$ )	kV	33
	tt) Maximum system voltage ( $U_m$ )	kV	36
	uu) Supply frequency	Hz	50
	vv) BIL of equipment to be protected	kV peak	200
3.3	• <b>Electrical characteristics of arrester</b>		
	v) Arrester classification		Distribution class
	w) IEC line discharge class		1
	x) Nominal lightning discharge current (8/20 $\mu$ s)	kA	10
	y) Energy in per unit of $U_r$ , with two high current impulses (4/10, 100kA) as tested in the operating duty test	kJ/kV	XXXXXXXXXX
	z) Arrester rated voltage ( $U_r$ )	kV	XXXXXXXXXX
	aa) MCOV ( $U_c$ )	kV	23.5
	bb) Maximum residual voltage ( $U_{res}$ ) at 10kA (8/20 $\mu$ s)	kV	100

Sub clause	Description	Schedule A		Schedule B	
		Item 1	Item 2	Item 1	Item 2
3.4	<ul style="list-style-type: none"> <li><b>Arrester housing</b></li> </ul>			Item 1	Item 2
	m) Housing material	xxxxxxxxxx			
	n) Colour of housing	xxxxxxxxxx			
	o) Minimum external creepage distance:	720	1116		
	p) Rated power frequency withstand voltage kV	70			
3.4.3	<ul style="list-style-type: none"> <li><b>Arrester housing profile design</b></li> </ul>			Item 1	Item 2
	IEC 60815 parameters:				
	s) c	37.	38. $\geq 20$		
	t) s/p	39.	40. $\geq 0,65$		
	u) $L_d/d$	41.	42. $\leq 5$		
	v) P1 – P2	43.	44. $\geq 15$		
	w) CF	45.	46. $\leq 3,5$		
	x) PF	47.	48. $\geq 0,7$		
3.5	<ul style="list-style-type: none"> <li><b>Arrester mounting details</b></li> </ul>				
	p) Orientation	Vertical		xxxxxxxxxx	
	q) Method of mounting	Insulated mounting arm		xxxxxxxxxx	
	r) Diameter of mounting hole in bracket mm	14			
	s) Minimum bracket length, i.e. dimension C mm	$>130$			
	t) Supplied M12 x 50 mounting bolt, nut, serrated washer and three flat washers	Yes			
3.6	<ul style="list-style-type: none"> <li><b>Terminals</b></li> </ul>				
	j) Diameter of terminals mm	xxxxxxxxxx			
	k) Material: Line terminal	xxxxxxxxxx			
	Earth terminal	xxxxxxxxxx			
	l) Bolted connector on line terminal shall be suitable for clamping the following conductors:				
	Material	ACSR		xxxxxxxxxxxxxx	
	Type	Squirrel to Hare		xxxxxxxxxxxxxx	
	Diameter mm	6 to 14			
3.7	<ul style="list-style-type: none"> <li><b>Ground leads</b></li> </ul>				
	s) Supplied flexible ground lead	Yes			
	t) Minimum length mm	300			
	u) Diameter of hole on free end mm	14			
	v) Type (e.g. flat strip, braid etc.)	xxxxxxxxxx			
	w) Material	xxxxxxxxxx			

Sub clause	Description	Schedule A	Schedule B	
	x) Outline dimensions	xxxxxxxxxx		
3.8	<ul style="list-style-type: none"> <li><b>Ground lead disconnecter</b></li> </ul>			
	g) Product code	xxxxxxxxxx		
	h) Resistance of internal resistor $\Omega$	xxxxxxxxxx		
3.9.1	<ul style="list-style-type: none"> <li><b>Drawings to be submitted with tender</b></li> </ul>			
	Single copies of drawings shall be submitted as part of the original tender showing the following detail:			
	p) Dimensions A, B and C as specified in A.1	Reference number		
	q) Mounting details	Reference number		
	r) Line terminal and ground terminal	Reference number		
	s) Marking details	Reference number		
	t) GLD construction	Reference number		
3.9.2	<ul style="list-style-type: none"> <li><b>Arrester characteristic data required</b></li> </ul>			
	j) V-I characteristic curve, AC	Reference number		
	k) V-I characteristic curve, DC	Reference number		
	l) Temporary overvoltage withstand capability curve in per unit of MCOV, with and with-out prior duty.	Reference number		
	<ul style="list-style-type: none"> <li><b>Arrester temporary overvoltage capability, with prior duty.</b> (prior duty as defined in annex D, IEC 60099-4)</li> </ul>			
	j) Overvoltage applied for 1 s	pu of MCOV xxxxxxxxxx		
	k) Overvoltage applied for 5 s	pu of MCOV xxxxxxxxxx		
	l) Overvoltage applied for 10 s	pu of MCOV xxxxxxxxxx		
	<ul style="list-style-type: none"> <li><b>Physical dimensions of arresters</b></li> </ul>		Item 1	Item 2
	m) Dimension A	mm	200 to 300	
	n) Dimension B	mm	75	
	o) External flashover distance	mm	xxxxxxxxxx	
	p) External diameter of arrester housing	mm	xxxxxxxxxx	
	<ul style="list-style-type: none"> <li><b>MOV elements</b></li> </ul>			
	j) Diameter of elements	mm	xxxxxxxxxx	_____
	k) Thickness of elements	mm	xxxxxxxxxx	_____
	l) Number of elements per arrester		xxxxxxxxxx	_____

Sub clause	Description	Schedule A	Schedule B
	<ul style="list-style-type: none"> <li><b>Miscellaneous</b></li> </ul>		
	j) Total mass of assembled unit kg	xxxxxxxxxx	_____
	k) Minimum expected life of arrester at 40 °C and MCOV yrs	25	_____
	l) Sample available for inspection	Yes	_____
4.2.1	<ul style="list-style-type: none"> <li><b>Insulation withstand test</b></li> </ul>		
	j) Reference number of test report	xxxxxxxxxx	_____
	k) Lightning impulse (1,2/50µs) withstand level [(1,3/0,82) × $U_{res}$ ] kV	151	_____
	l) 60 s wet power frequency withstand r.m.s kV	70	_____
4.2.2	<ul style="list-style-type: none"> <li><b>Insulation withstand test on insulated mounting bracket</b></li> </ul>		
	g) Provide reference number of test report	xxxxxxxxxx	_____
	h) 10 s wet withstand from earth terminal to earthed mounting bracket [1,5 x MCOV] kV	35	_____
4.2.3	<ul style="list-style-type: none"> <li><b>Residual voltage test</b></li> </ul>		
	j) Reference number of test report	xxxxxxxxxx	_____
	k) Maximum residual voltage for a 10 kA steep current impulse (1/20µs) [4 x $U_r$ ] kV	120	_____
	l) Maximum residual voltage for a lightning current impulse (8/20µs) of magnitude:		
	5 kA kV	xxxxxxxxxx	_____
	10 kA kV	100	_____
	20 kA kV	xxxxxxxxxx	_____
4.2.4	<ul style="list-style-type: none"> <li><b>Long duration current impulse withstand test</b></li> </ul>		
	bb) Reference number of test report	xxxxxxxxxx	_____
	cc) Charging voltage pu of $U_r$	3,2	_____
	or		
	charging current A	xxxxxxxxxx	_____
	dd) Virtual duration of peak µs	2000	_____
	ee) Number of discharge operations	18	_____
	ff) Number of grouped operations	6	_____
	gg) Operations per group	3	_____
	hh) Maximum interval between operations s	60	_____
	ii) Interval between groups	Cool to ambient	_____
	jj) Maximum permitted change in residual voltage after long duration current impulse withstand test %	5	_____
4.2.5	<ul style="list-style-type: none"> <li><b>Operating duty test</b></li> </ul>		
	tt) Reference number of test report	xxxxxxxxxx	_____
	<b>Conditioning part 1:</b>		

Sub clause	Description		Schedule A	Schedule B
	uu) 10 kA current impulse (8/20 $\mu$ s), energized at 1,2 x MCOV	kV	28.5	
	vv) Number of discharge operations		20	
	ww) Number of grouped operations		4	
	xx) Operations per group		5	
	yy) Interval between operations	s	60	
	zz) Intervals between groups	min	30	
	<b>Conditioning part 2:</b>			
	aaa) High current impulse (4/10 $\mu$ s)	kA	100	
	bbb) Number of applications		2	
	ccc) Starting temperature for first impulse	°C	20	
	ddd) Starting temperature for second impulse	°C	60	
	<b>Conditions for power frequency test at elevated levels as in IEC 60099-4, 7.5.2:</b>			
	eee) Interval between last long duration current impulse and power frequency test	ms	100	
	fff) Elevated rated voltage ( $U_r^*$ ) applied for 10 s	kV	xxxxxxxxxx	
	ggg) Elevated continuous operating voltage ( $U_c^*$ ) applied for 30 min	kV	xxxxxxxxxx	
	hhh) Maximum permitted change in residual voltage after long duration current impulse withstand test	%	5	
4.2.6	<b>• Power frequency voltage versus time characteristic</b>			
	d) Reference number of test report		xxxxxxxxxx	
4.2.7	<b>• Short-circuit test</b>			
	j) Reference number of test report		xxxxxxxxxx	
	k) High current	kA r.m.s.	20	
	l) Low current	kA r.m.s.	0,6 $\pm$ 0,2	
4.2.10	<b>• Natural ageing and pollution performance test</b>			
	d) Reference number of test report		xxxxxxxxxx	
4.2.8	<b>• Internal partial discharge test</b>			
	j) Reference number of test report		xxxxxxxxxx	
	k) Power frequency voltage applied [1,05 x MCOV]	kV	10.5	
	l) Maximum partial discharge	pC	10	
4.2.9	<b>• Water Immersion test</b>			
	d) Reference number of test report		xxxxxxxxxx	
4.2.11.1	<b>• GLD long duration current impulse withstand test</b>			
	d) Provide reference number of test report		xxxxxxxxxx	
4.2.11.2	<b>30. GLD time versus current curve test</b>			

Sub clause	Description	Schedule A	Schedule B
	d) Provide reference number of test report	XXXXXXXXXX	
4.2.11.3	<b>4. GLD operating duty test</b>		
	g) Provide reference number of test report	XXXXXXXXXX	
	h) Disconnecter operating time at current levels:		
	5 A r.m.s. s	< 3	
	20 A r.m.s. s	XXXXXXXXXX	
	200 A r.m.s. s	XXXXXXXXXX	
	800 A r.m.s.	XXXXXXXXXX	
4.2.11.4	<b>• GLD high lightning duty current impulse withstand test</b>		
	d) Provide reference number of test report	XXXXXXXXXX	
4.2.11.5	<b>• GLD repetitive surge withstand ability test</b>		
	d) Provide reference number of test report	XXXXXXXXXX	
4.2.11.6	<b>• GLD water immersion test</b>		
	d) Provide reference number of test report	XXXXXXXXXX	
4.2.11.7	<b>• GLD mechanical test</b>		
	d) Provide reference number of test report	XXXXXXXXXX	

### Deviation schedule

Any deviations from this specification shall be listed below with reasons for deviation. In addition, evidence shall be provided that the proposed deviation will at least be more cost-effective than that specified by Eskom.

Item	Clause	Proposed deviation