



TDR147/2025/2026

**CONSTRUCTION OF NEW OFFICES FOR THE K9 DOG UNIT ON ERF 2001,
EXTENSION 23, MOSSEL BAY MUNICIPALITY**

CLOSING DATE: 17 JULY 2026	CLOSING TIME: 12h00
NAME OF BIDDER* (Registered name)	
TRADING NAME*(if different from above)	
ADDRESS*	
TELEPHONE NUMBER*	
CELLPHONE NUMBER*	
E-MAIL ADDRESS*	
CENTRAL SUPPLIER DATABASE REGISTRATION NR*	
B-BBEE LEVEL OF CONTRIBUTION*	
LOCALITY (Municipal Area/Province where Business is Located) *	
CIDB REGISTRATION NR* (if applicable)	
TENDER AMOUNT (VAT included) *	

(* - TO BE COMPLETED BY BIDDER)

Prepared by:
Mossel Bay Municipality
PO Box 25
Mossel Bay
6500

INDEX

SECTION 1		PAGE nr
1.1	INVITATION TO TENDER	3
1.2	TENDER CONDITIONS AND INFORMATION	5
1.3	GENERAL CONDITIONS OF CONTRACT	14
1.4	SPECIAL CONDITIONS OF TENDER	20
1.5	FUNCTIONALITY	22
SECTION 2		
2.1	SCOPE OF WORK	33
2.2	CONDITIONS OF CONTRACT	29
2.2	BILL OF QUANTITIES	38
SECTION 3		
3.1	MBD1: BID REQUIREMENTS OF THE MOSSEL BAY MUNICIPALITY	41
SECTION 4		
4.1	MBD4: DECLARATION OF INTEREST	44
4.2	MBD5: DECLARATION FOR PROCUREMENT ABOVE R10 MILLION	47
4.3	MBD6.1: PREFERENCE POINTS CLAIM FORM IN TERMS OF THE PREFERENTIAL PROCUREMENT REGULATIONS, 2022	48
4.4	MUNICIPAL RATES AND TAXES	52
4.5	AUTHORISED SIGNATORY	54
4.6	MBD8: DECLARATION OF BIDDER'S PAST SUPPLY CHAIN MANAGEMENT PRACTICES	56
4.7	MBD9: CERTIFICATE OF INDEPENDENT BID DETERMINATION	58
SECTION 5	DECLARATION	61
SECTION 6	CONTRACT FORM	62
	FORM OF OFFER & ACCEPTANCE	63
	JOINT VENTURE AGREEMENT	66
	OHS SPECIFICATIONS	69
SECTION 6	TENDER DRAWINGS & NOTES	100

SECTION 1.1: INVITATION TO TENDER

CLOSING TIME: 12h00

CLOSING DATE: 17 JULY 2026

TDR147/2025/2026: CONSTRUCTION OF NEW OFFICES FOR THE K9 DOG UNIT ON ERF 2001, EXTENSION 23, MOSSEL BAY MUNICIPALITY

Tenders are hereby invited from Contractors with a CIDB grading of 3GB or higher for New Offices for the K9 Dog Unit.

A set of fully completed tender documents must be submitted on the original documents and remain valid for 90 days after the closing date of the tender. Enquiries about the tender can be addressed to Mr D Zwiendelaar at telephone (044) 606 5150 or e-mail dzwiendelaar@mosselbay.gov.za or Mr W Molashe at telephone (044) 606 5145 or e-mail wmolashe@mosselbay.gov.za Enquiries pertaining to the completion of the documents can be addressed to Mr. Deslin Kohler at telephone (044) 606-5192 or e-mail to dkohler@mosselbay.gov.za.

A compulsory site and information meeting will take place at 11h00 on **Wednesday, 24 JUNE 2026** at the Committee Room of the Building Maintenance Department, Montagu Place, Montagu Street (GPS Co-Ordinates 34° 11' 0.61" S 022° 08' 32.05"E).

ALL BIDDERS, including ALL THE PARTNERS OF A JOINT VENTURE MUST BE CIDB REGISTERED AND ATTEND THIS COMPULSORY MEETING.

BIDDERS (including all partners of a Joint Venture) WHO DID NOT ATTEND THE COMPULSORY SITE AND INFORMATION MEETING AND SUBMIT A BID, WILL BE SEEN AS SUBMITTING A NON-RESPONSIVE BID.

Please note: The Municipality prefer that Senior Company Staff members or Contract Managers attend the compulsory site meeting as the Scope of Works, the Design and the Tender Specifications will be discussed in detail along with the Execution phase expectations and possible amendments. It remains the Bidder's responsibility to familiarise themselves with and fully understand the tender specifications to be able to submit a responsive tender.

Prospective bidders that arrive 15 minutes or more after the advertised time the meeting started will not be allowed to attend the meeting or to sign the attendance register. If a prospective bidder is delayed, he/she must inform the contact person before the meeting commence and he/she will only be allowed to attend the meeting if the chairperson of the meeting, as well as all the other bidders attending the meeting, give permission to do so.

A set of tender documents can be obtained at a non-refundable cost of R394.00 per set from Mr. Deslin Kohler who may be contacted at telephone (044) 606-5192 or e-mail at dkohler@mosselbay.gov.za **OR** it can be obtained on our website at www.mosselbay.gov.za free of charge. If you require a hard copy of the tender document, payments must be made at the cashiers at the **Mossel Bay Municipality's Main Building, 101 Marsh Street on the Lower Ground Floor (seaside)** or EFT (Banking details and Reference Nr can be obtained from esnyders@mosselbay.gov.za), prior to collecting and proof of payment must be provided when collecting the tender document from the Supply Chain Management Offices, 101 Marsh Street, Mossel Bay.

Fully completed tender documents must be placed in a sealed envelope and placed in the tender box at the Entrance of the Mossel Bay Town Hall, 101 Marsh Street, Mossel Bay by not later than **12h00 on Friday, 17 JULY 2026**, 6500 before the specified closing date and time. The envelopes must be endorsed clearly with the number, title and closing date of the tender as above.

Bids will be pre-evaluated on the following functionality criteria and bids that score less than **60 out of 75** points will be considered as non-responsive:

Functionality criteria and weight:

1. Company (or JV) Experience carrying a weight of 30 points.
2. References related to experience carrying a weight of 15 points.
3. Key Site Staff and Personnel carrying a weight of 30 points.

Responsive bids will be evaluated on the 80/20 or 90/10 Preference Points System. A maximum of 20 points (80/20 preference point system) or 10 points (90/10 preference point system) will be allocated for specific goals. 50% of the 20/10 points will be allocated in terms of a bidder's B-BBEE scorecard and other 50% of the 20/10 points will be for a bidder's locality.

The tender box will be emptied just after 12h00 on the closing date as above, hereafter all bids will be opened in public. Late tenders or tenders submitted by e-mail or fax will under no circumstances be accepted.

The Municipality reserves the right to withdraw any invitation to tender and/or to re-advertise or to reject any tender or to accept a part of it. The Municipality does not bind itself to accepting the lowest tender or award a contract to the bidder scoring the highest number of points.

It is expected of all Bidders who are not yet registered on the Central Supplier Database to register without delay on the prescribed form. The Municipality reserves the right not to award tenders to Bidders who are not registered on this Database.

MR C PUREN
MUNICIPAL MANAGER

SECTION 1.2: TENDER CONDITIONS AND INFORMATION

1.2.1 General and Special Conditions of Contract

The General Conditions of Contract (GCC) available on the National Treasury website <http://www.treasury.gov.za/divisions/ocpo/sc/GeneralConditions/> will be applicable to this tender as well as Special Conditions of Contract (SCC) (if applicable) forming part of this set of tender documents in addition to the conditions and information. Where the GCC and SCC are in conflict with one another, the stipulations of the SCC will prevail.

1.2.2 Acceptance or Rejection of a Tender

The Municipality reserves the right to withdraw any invitation to tender and/or to re-advertise or to reject any tender or to accept a part of it. The Municipality does not bind itself to accepting the lowest tender or the tender scoring the highest points.

1.2.3 Validity Period

Bids shall remain valid for **one-hundred and twenty (120) days** after the tender closure date.

1.2.4 Cost of Tender Documents

A set of tender documents can be obtained at a non-refundable cost of R394.00 per set from Mr. Deslin Kohler who may be contacted at telephone (044) 606-5192 or e-mail at dkohler@mosselbay.gov.za **OR** it can be obtained on our website at www.mosselbay.gov.za free of charge. If you require a hard copy of the tender document, payments must be made at the cashiers at the **Mossel Bay Municipality's Main Building, 101 Marsh Street on the Lower Ground Floor (seaside)** or EFT (Banking details and Reference Nr can be obtained from esnyders@mosselbay.gov.za), prior to collecting and proof of payment must be provided when collecting the tender document from the Supply Chain Management Offices, 101 Marsh Street, Mossel Bay.

1.2.5 Registration on the Central Supplier Database

It is expected of all prospective service providers who are not yet registered on the Central Supplier Database to register without delay on the prescribed form. The Municipality reserves the right not to award tenders to prospective suppliers who are not registered on this Database.

1.2.6 Completion of Tender Documents

- (a) The original tender document must be fully completed and originally signed in black ink and signed by the authorised signatory to validate the tender. Section 5: DECLARATION must be completed and signed by the authorised signatory and returned. Failure to do so will result in the disqualification of the tender and will not be evaluated.
- (b) Tender documents may not be retyped. Retyped documents will result in the disqualification of the tender and will not be evaluated.
- (c) The complete original tender document must be returned. Material pages that are omitted from the tender document may result in the disqualification of the tender and the bidder will not be evaluated. The Municipality reserves the right to request immaterial pages that were omitted.

- (d) No unauthorised alteration of this set of tender documents will be allowed. Any unauthorised alteration will disqualify the tender automatically. Any ambiguity has to be cleared with contact person for the tender before the tender closure.
- (e) The tender document as provided by the Municipality's Supply Chain Management Section will be the prevailing document in the event of an inconsistency between the completed submitted tender document by a bidder and the tender document provided by the Municipality.

1.2.7 Compulsory Documentation

1.2.7.1 Tax Clearance Certificate

- (a) A copy of a Tax Compliance Status Pin, printed from the South African Revenue Service (SARS) website, must accompany the bid documents. The onus is on the bidder to ensure that their tax matters with SARS are in order.
- (b) In the case of a Consortium/Joint Venture every member must submit a separate Tax Compliance Status Pin, printed from the SARS website, with the bid documents.
- (c) If a bid is not supported by a Tax Compliance Status Pin as an attachment to the bid documents, the Municipality reserves the right to obtain such documents after the closing date to verify that the bidder's tax matters are in order. If no such document can be obtained within a period as specified by the Municipality, the bid will be disqualified.
- (d) The Tax Compliance Status Pin will be verified by the Municipality on the SARS website.

1.2.8 Other Documentation

1.2.8.1 Construction Industry Development Board (CIDB) (If applicable)

When applicable, the bidder's CIDB registration number must be included with the tender. The Municipality will verify the bidder's CIDB registration during the evaluation process.

- (a) The conditions of tender are the Standard Conditions of Tender as contained in Annexure F of the CIDB Standard of Uniformity in Construction in Procurement (May 2010) as published in Government Gazette No 31823, Board Notice 11 of 2009 of 30 January 2009. (See www.cidb.org.za)
- (b) Only those tenderers who are registered with the CIDB, or are capable of being so prior to the evaluation of submissions, in a contractor grading designation equal to or higher than the contractor grading designation determined in accordance with the sum tendered, or a value determined in accordance with Regulation 25 (1B) or 25 (7A) of the Construction Industry Development Regulations, for a **3GB** or higher class of construction work, are eligible to have their tenders evaluated.
- (c) Joint Ventures are eligible to submit tenders provided that;
 - Every member of the joint venture is registered with the CIDB;
 - The lead partner has a contractor grading designation in the **3GB** or higher class of construction work; and
- (d) The combined contractor grading designation calculated in accordance with the Construction Industry Development Regulations is equal or higher than a contractor grading designation determined in accordance with the sum tendered for a **3GB** or higher class of construction work or a value determined in accordance with Regulation 25 (1B) or 25 (7A) of the Construction Industry Development Regulations.

Tender offers will only be accepted if:

- (e) The Bidder is registered with the Construction Industry Development Board (CIDB) in the appropriate CIDB Contractor grading designation before the tender closing date/time;
- (f) The Bidder or any of its directors is not listed in the Register of Tender Defaulters in terms of the Prevention and Combating of Corrupt Activities Act of 2004 as a person prohibited from doing business with the public sector;
- (g) The Bidder has not:
 - (i) Abused the Employer's Supply Chain Management System; or
 - (ii) Failed to perform on any previous contract and has been given a written notice to this effect.
- (h) The Bidder has completed the Compulsory Enterprise Questionnaire and there are no conflicts of interest which may impact on the bidder's ability to perform the contract in the best interests of the Employer or potentially compromise the tender process and persons in the employ of the State are permitted to submit bids or participate in the contract;
- (i) The Bidder is registered and in good standing with the compensation fund or with licensed compensation insurer;
- (j) The Employer is reasonably satisfied that the bidder has in terms of the Construction Regulations, 2014, issued in terms of the Occupational Health and Safety Act, 1993, the necessary competencies and resources to carry out the work safely.

1.2.8.2 Municipal Rates, Taxes and Charges

- (a) A copy of the bidder's and those of its director's/members municipal accounts (for the Municipality where the bidder and its director's/members pay their account) for the month preceding the tender closure date must accompany the tender documents. If such a copy does not accompany the bid document of the successful bidder, the Municipality reserves the right to obtain such documents after the closing date to verify that their municipal accounts are in order.
- (b) Any bidder which is or whose directors are in arrears with their municipal rates and taxes or municipal charges due to any Municipality or any of its entities for more than three months and have not made an arrangement for settlement of same before the bid closure date will be unsuccessful. The arrangement for settlement for the outstanding amount (which were done before the closing date of the bid), must also be submitted with the tender document.
- (c) If a bidder and its director's/members rent their premises, the current lease agreement must be submitted with the tender document, which indicates that the rental includes their municipal rates and taxes. If the lease agreement indicates that the bidder or its director's/members are responsible to pay the municipal rates and taxes, the Municipal Account of the leased premises indicated must also be submitted.
- (d) If a bidder and its director's/members, do not own any property, they must submit the following:
 - (i) Affidavit from the bidder and its director's/members, that they do not own any property;
 - (ii) Affidavit from the owner of the property where business is situated/director's/members reside, that the bidder and its director's/members are not liable for the municipal rates and taxes.
- (e) If a bidder or its director's/members, lives outside of South Africa, an affidavit by the Company must be submitted.

1.2.9 Authorised Signatory

- (a) A copy of the recorded Resolution taken by the Board of Directors, members, partners or trustees authorising the representative to submit this bid on the bidder's behalf must be attached to the Bid Document on submission of same.
- (b) A bid shall be eligible for consideration only if it bears the signature of the bidder or of some person duly and lawfully authorised to sign it for and on behalf of the bidder.
- (c) If such a copy of the Resolution does not accompany the bid document of the successful bidder, the Municipality reserves the right to obtain such document after the closing date to verify that the signatory is in order. If no such document can be obtained within a period as specified by the Municipality, the bid will be disqualified and will not be evaluated.
- (d) If a bidder is a sole proprietor, no such documentation is required, provided that the document was completed and signed by the owner.

1.2.10 Site / Information Meetings

- (a) Site or information meetings, if specified (in the advert), are **compulsory**. Bids will not be accepted from bidders who have not attended the compulsory site or information or online briefing meetings. Bidders that arrive or log in 15 minutes or more after the advertised time the meeting starts will not be allowed to attend the meeting or to sign the attendance register. If a bidder is delayed/have connection problems, he/she must inform the contact person before the meeting commence and will only be allowed to attend the meeting if the chairperson of the meeting as well as all the other bidders attending the meeting, give permission to do so.
- (b) All bidders, including **ALL THE PARTNERS OF A JOINT VENTURE** must attend the compulsory site or information or online briefing meeting.

1.2.11 Samples

Samples, if requested, are to be provided to the Municipality with the tender document or as stipulated.

1.2.12 Quantities of Specific Items

If tenders are called for a specific number of items, the Municipality reserves the right to change the number of such items to be higher/more or lower/less. If the successful bidder does not accept the new scenario, it will be offered to the second-placed bidder.

1.2.13 Submission of Tender

- (a) The tender must be placed in a sealed envelope, or envelopes when the two-envelope system is specified, clearly marked with the tender number, title as well as closing date and time and placed in the **tender box at the Entrance of the Mossel Bay Town Hall, 101 Marsh Street, Mossel Bay Municipality by not later than 12h00 on Friday, 17 JULY 2026.**
- (b) Faxed, e-mailed and late tenders will not be accepted. Tenders may be delivered by hand, by courier, or posted at the bidder's risk and must be received by the deadline specified above, irrespective of how they are sent or delivered.

1.2.14 Expenses Incurred in Preparation of Tender

The Municipality shall not be liable for any expenses incurred in the preparation and submission of the tender.

1.2.15 Contact with Municipality after Tender Closure Date

Bidders shall not contact the Mossel Bay Municipality on any matter relating to their bid from the time of the opening of the bid to the time the contract is awarded. If a bidder wishes to bring additional information to the notice of the Mossel Bay Municipality, it should do so in writing to the Mossel Bay Municipality. Any effort by the firm to influence the Mossel Bay Municipality in the bid evaluation, bid comparison or contract award decisions may result in the rejection of the bid.

1.2.16 Opening, Recording and Publications of Tenders Received

(a) Tenders will be opened on the closing date immediately after the closing time specified in the tender documents. If requested by any bidder present, the names of the bidders, and if practical, the total amount of each bid and of any alternative offers will be read out aloud.

(b) Details of tenders received in time will be recorded in a register which is open to public inspection.

1.2.17 Evaluation of Tenders

Tenders will be evaluated in terms of their responsiveness to the tender specifications and requirements as well as such additional criteria as set out in this set of tender documents.

1.2.18 Procurement Policy

Bids will be awarded in accordance with the Preferential Procurement Regulations, 2007 pertaining to the Preferential Procurement Policy Framework Act, No 5 of 2000 and its amendments as well as the Municipality's Supply Chain Management and the current Municipal Preferential Procurement Policy.

1.2.19 Contract

The successful bidder will be expected to sign the agreement in Section 6 of this bid document. The signing of both Parts of Section 6 of this bid document signifies the conclusion of the contract. The Municipality, at its discretion, may request the signing of an additional Service Level Agreement which, together with the signed tender document, will constitute the full agreement between the Municipality and the successful bidder.

1.2.20 Subcontracting

(a) The Contractor shall not subcontract the whole of the Contract.

(b) Except where otherwise provided by the Contract, the Contractor shall not subcontract any part of the Contract without the prior written consent of the Municipality, which consent shall not be unreasonably withheld.

(c) The contractual relationship between the Contractor and any subcontractors selected by the Contractor in consultation with the Municipality in accordance with the requirements of and a procedure contained within the Scope of Work, shall be the same as if the Contractor had appointed the subcontractor in terms of paragraph (b) above.

- (d) Any consent granted in accordance with paragraph (b) or appointment of a subcontractor in accordance with paragraph (c) shall not imply a contract between the Municipality and the subcontractor, or a responsibility or liability on the part of the Municipality to the subcontractor and shall not relieve the Contractor from any liability or obligation under the Contract and he shall be liable for the acts, defaults and neglects of any subcontractor, his agents or employees as fully as if they were the acts, defaults or neglects of the Contractor, his agents or employees.
- (e) The Contractor shall not be required to obtain such consent for –
 - (i) the provision of labour, or
 - (ii) the purchase of materials which are in accordance with the Contract, or
 - (iii) the purchase or hire of Construction Equipment.

1.2.21 Language of Contract

The contract documents will be compiled in English and the English versions of all referred documents will be taken as applicable.

1.2.22 Extension of Contract

The Municipality reserves the right to negotiate the extension or expansion of a contract with the successful bidder should additional funds become available. This prescribed process in terms of legislation must be followed prior to any agreement being concluded and the vesting of any rights.

1.2.23 Stamp and Other Duties

The successful bidder will be liable for all duties and costs on legal documents resulting in the establishment of a contract and for the surety, guarantees and retentions.

1.2.24 Wrong Information Furnished

Where a contract has been awarded on the strength of the information furnished by the bidder which, after the conclusion of the relevant agreement, is proved to have been incorrect, the Municipality may, in addition to any other legal remedy it may have, recover from the contractor all costs, losses or damages incurred or sustained by the Municipality as a result of the award of the contract.

1.2.25 Past Practices

- (a) The bid of any bidder may be rejected if that bidder or any of its directors have abused the municipality's supply chain management system or committed any improper conduct in relation to such system.
- (b) The bid of any bidder may be rejected if it is or has been found that that bidder or any of its directors influenced or tried to influence any official or councillor with this or any past tender.
- (c) The bid of any bidder may be rejected if it is or has been found that that bidder or any of its directors offered, promised or granted any official or any of his/her close family members, partners or associates any reward, gift, favour, hospitality or any other benefit in any improper way, with this or any past tender.

1.2.26 DOCUMENTATION REQUIRED TO CLAIM POINTS FOR SPECIFIC GOALS

1.2.26.1 Proof of B-BBEE Status Level of Contributor:

- (a) A sworn affidavit as prescribed by the B-BBEE Codes of Good Practice; or
- (b) Any other requirement prescribed in terms of the Broad-Based Black Economic Empowerment Act, as indicated below:

- **If the certificate was issued by a verification agency the following must be on the face of the certificate:**

SANAS logo, unique BVA number, must be an original certificate or certified copy of the original, the name and physical location of the bidder, the registration number and, where applicable, the VAT number of the bidder, the date of issue and date of expiry of the certificate, the certificate number for identification and reference, the scorecard that was used (for example EME, QSE or Generic), the name and / or logo of the Verification Agency, the certificate must be signed by the authorized person from the Verification Agency and the B-BBEE Status Level of Contribution obtained by the bidder.

- **If certificate was issued by an Auditor/ Accounting Officers:**

The Accounting Officer's or Registered Auditor's letter head with full contact details, the Accounting Officer's or Registered Auditor's practice numbers, the name and the physical location of the bidder, the registration number and, where applicable, the VAT number of the bidder, the date of issue and date of expiry, the B-BBEE Status Level of Contribution obtained by the measured entity, the total black shareholding and total black female shareholding, the B-BBEE Status Level of Contribution obtained by the bidder and must be an original certificate or certified copy of the original.

- **If the certificate was issued by registered auditors approved by IRBA**

Clearly identify the B-BBEE approved registered auditor by the auditor's individual registration number with IRBA and the auditor's logo, clearly record an approved B-BBEE Verification Certificate identification reference in the format required by the SASAE, reflect relevant information regarding the identity and location of the measured entity, identify the Codes of Good Practice or relevant Sector Codes applied in the determination of the scores, record the weighting points (scores) attained by the measured entity for each scorecard element, where applicable, and the measured entity's overall B-BBEE Status Level of Contribution, reflect that the B-BBEE Verification Certificate and accompanying assurance report issued to the measured entity is valid for 12 months from the date of issuance and reflect both the issuance and expiry date, and the B-BBEE Status Level of Contribution obtained by the bidder and must be an original certificate or certified copy of the original.

1.2.26.2 Proof of Locality in a Specific Province, Region and Municipal Area

- (a) Points for specific goals to promote suppliers or service providers located in a province, district or municipal area / (hereafter referred to as locality).
- (b) Each tender must specify in the invitation to tender that a maximum of 50% of the 20/10 points will be allocated to promote the specific goal of locality.
- (c) Only one of the points as set out below that best describes the enterprise's locality may be awarded if applicable.

No	Requirement	Points for enterprises within Mossel Bay municipal area	Points for enterprises within Garden Route District region	Points for enterprises within the Western Cape Province and other Provinces
1	Procurement under the 80/20 preference points system where the supplier or service provider is located in:	10	6	4
2	Procurement under the 90/10 preference points system where the supplier or service provider is located in:	5	3	2

(d) Bidders must submit one of the following in order to receive points for the abovementioned criterion.

- (i) Municipal Account of bidder's address as indicated in bid document;
- (ii) If the address as indicated in bid document is not in the name of the bidder, the latest lease agreement for this address or sworn affidavit from the registered owner of the property stating occupancy by the bidder is required.
- (iii) The business address of the bidder as indicated in the MBD6.1 of the bid document as the business premises should be established/leased prior to the advertisement date.
- (iv) Only fully operational business premises will be accepted. All vacant erven, storage units and postal addresses do not qualify as a business premises.

1.2.28 Letter of Good Standing from the Commissioner of Compensation

- (a) A valid AND relevant Letter of Good Standing from the Compensation Commissioner or a copy thereof, must accompany the bid documents.
- (b) In the case of a Consortium/Joint Venture every member must submit a separate valid AND relevant Letter of Good Standing from the Compensation Commissioner or a copy thereof with the bid documents.
- (c) If a bid is not supported by a valid AND relevant Letter of Good Standing from the Compensation Commissioner or a copy thereof, as an attachment to the bid documents, the Municipality reserves the right to obtain such document after the closing date. If no such document can be obtained within a period as specified by the Municipality, the bid will be disqualified.
- (d) If a bid is accompanied by proof of application for valid AND relevant Letter of Good Standing from the Compensation Commissioner, the original or copy thereof must be submitted on/or before the final date of award.
- (e) Should a bidder's Letter of Good Standing from the Compensation Commissioner expire during the contract period, a valid AND relevant certificate must be submitted within an agreed upon time.
- (f) The right is reserved to not award a tender if a valid AND relevant Letter of Good Standing from the Compensation Commissioner or a certified copy thereof is not submitted within the requested time.

1.2.29 Negotiations

Should the tender prices be higher than the available funds of the client, the client reserves the right to negotiate with the successful bidder to limit the work in accordance with the tender specifications in order not to exceed the available budget. These negotiations can be done prior or after the final award.

1.2.30 Joint Ventures

The Joint venture agreement must be submitted as part of the bid documents;

- (a) No amendments to Joint venture agreement may be made without the prior approval of the Municipality; if not accepted by the Municipality and the Joint venture continue without approval the Joint venture contract can be cancelled as if poor performance had taken place;
- (b) Joint venture will only qualify for points for their B-BBEE status level as a legal entity, provided that the entity submits, together with the submission of the bid, their B-BBEE status level certificate issued in the name of the Joint venture.
- (c) Joint venture will only qualify for points for Locality as a legal entity, provided that the entity submits the address of the Lead Partner as per the Joint Venture agreement.
- (d) If the joint venture division is 50/50 the points will be allocated according to the closest address.
- (e) All members of the Joint venture must submit, with the bid documents:
 - a valid SARS tax pin, individually;
 - an agreement that clearly provides clarity of Profit and liability sharing; and
 - a resolution taken by the board of directors of the Joint venture and other information that agrees with the Joint venture agreement as detailed on pages **64-66**.
- (f) For the evaluation of functionality regarding a Joint venture refer to the functionality section.

1.2.31 Enquiries

Enquiries in connection with this tender, prior to the tender closure date, may be addressed to Mr D Zwiigelaar at telephone (044) 606 5150 or e-mail dzwiigelaar@mosselbay.gov.za or Mr W Molashe at telephone (044) 606 5145 or e-mail wmolashe@mosselbay.gov.za

oooOOOooo

1.3 GENERAL CONDITIONS OF CONTRACT

1. Definitions

1. The following terms shall be interpreted as indicated:

- 1.1 "Closing time" means the date and hour specified in the bidding documents for the receipt of bids.
- 1.2 "Contract" means the written agreement entered into between the purchaser and the supplier, as recorded in the contract form signed by the parties, including all attachments and appendices thereto and all documents incorporated by reference therein.
- 1.3 "Contract price" means the price payable to the supplier under the contract for the full and proper performance of his contractual obligations.
- 1.4 "Corrupt practice" means the offering, giving, receiving, or soliciting of anything of value to influence the action of a public official in the procurement process or in contract execution.
- 1.5 "Countervailing duties" are imposed in cases where an enterprise abroad is subsidized by its government and encouraged to market its products internationally.
- 1.6 "Country of origin" means the place where the goods were mined, grown or produced or from which the services are supplied. Goods are produced when, through manufacturing, processing or substantial and major assembly of components, a commercially recognized new product results that is substantially different in basic characteristics or in purpose or utility from its components.
- 1.7 "Day" means calendar day.
- 1.8 "Delivery" means delivery in compliance of the conditions of the contract or order.
- 1.9 "Delivery ex stock" means immediate delivery directly from stock actually on hand.
- 1.10 "Delivery into consignees store or to his site" means delivered and unloaded in the specified store or depot or on the specified site in compliance with the conditions of the contract or order, the supplier bearing all risks and charges involved until the goods are so delivered and a valid receipt is obtained.
- 1.11 "Dumping" occurs when a private enterprise abroad market its goods on own initiative in the RSA at lower prices than that of the country of origin and which have the potential to harm the local industries in the RSA.
- 1.12 "Force majeure" means an event beyond the control of the supplier and not involving the supplier's fault or negligence and not foreseeable. Such events may include, but is not restricted to, acts of the purchaser in its sovereign capacity, wars or revolutions, fires, floods, epidemics, quarantine restrictions and freight embargoes.
- 1.13 "Fraudulent practice" means a misrepresentation of facts in order to influence a procurement process or the execution of a contract to the detriment of any bidder, and includes collusive practice among bidders (prior to or after bid submission) designed to establish bid prices at artificial non-competitive levels and to deprive the bidder of the benefits of free and open competition.
- 1.14 "GCC" means the General Conditions of Contract.
- 1.15 "Goods" means all of the equipment, machinery, and/or other materials that the supplier is required to supply to the purchaser under the contract.
- 1.16 "Imported content" means that portion of the bidding price represented by the cost of components, parts or materials which have been or are still to be imported (whether by the supplier or his subcontractors) and which costs are inclusive of the costs abroad, plus freight and other direct importation costs such as landing costs, dock dues, import duty, sales duty or other similar tax or duty at the South African place of entry as well as transportation and handling charges to the factory in the Republic where the goods covered by the bid will be manufactured.
- 1.17 "Local content" means that portion of the bidding price, which is not included in the imported content provided that local manufacture does take place.
- 1.18 "Manufacture" means the production of products in a factory using labour, materials, components and machinery and includes other related value-adding activities.
- 1.19 "Order" means an official written order issued for the supply of goods or works or the rendering of a service.
- 1.20 "Project site," where applicable, means the place indicated in bidding documents.
- 1.21 "Purchaser" means the organization purchasing the goods.
- 1.22 "Republic" means the Republic of South Africa.
- 1.23 "SCC" means the Special Conditions of Contract.
- 1.24 "Services" means those functional services ancillary to the supply of the goods, such as transportation and any other incidental services, such as installation, commissioning, provision of technical assistance, training, catering, gardening, security, maintenance and other such obligations of the supplier covered under the contract.
- 1.25 "Supplier" means the successful bidder who is awarded the contract to maintain and administer the required and specified service(s) to the State.
- 1.26 "Tort" means in breach of contract.
- 1.27 "Turnkey" means a procurement process where one service provider assumes total responsibility for all aspects of the project and delivers the full end product / service required by the contract.
- 1.28 "Written" or "in writing" means hand-written in ink or any form of electronic or mechanical writing.

2. Application

- 2.1 These general conditions are applicable to all bids, contracts and orders including bids for functional and professional services (excluding professional services related to the building and construction industry), sales, hiring, letting and the granting or acquiring of rights, but excluding immovable property, unless otherwise indicated in the bidding documents.
- 2.2 Where applicable, special conditions of contract are also laid down to cover specific goods, services or works.
- 2.3 Where such special conditions of contract are in conflict with these general conditions, the special conditions shall apply.

3. General

- 3.1 Unless otherwise indicated in the bidding documents, the purchaser shall not be liable for any expense incurred in the preparation and submission of a bid. Where applicable a non-refundable fee for documents may be charged.
- 3.2 Invitations to bid are usually published in locally distributed news media and on the municipality/municipal entity website.

4. Standards

4.1 The goods supplied shall conform to the standards mentioned in the bidding documents and specifications.

5. Use of contract documents and information inspection

5.1 The supplier shall not, without the purchaser's prior written consent, disclose the contract, or any provision thereof, or any specification, plan, drawing, pattern, sample, or information furnished by or on behalf of the purchaser in connection therewith, to any person other than a person employed by the supplier in the performance of the contract. Disclosure to any such employed person shall be made in confidence and shall extend only so far as may be necessary for purposes of such performance.

5.2 The supplier shall not, without the purchaser's prior written consent, make use of any document or information mentioned in GCC clause 5.1 except for purposes of performing the contract.

5.3 Any document, other than the contract itself mentioned in GCC clause 5.1 shall remain the property of the purchaser and shall be returned (all copies) to the purchaser on completion of the supplier's performance under the contract if so required by the purchaser.

5.4 The supplier shall permit the purchaser to inspect the supplier's records relating to the performance of the supplier and to have them audited by auditors appointed by the purchaser, if so required by the purchaser.

6. Patent Rights

6.1 The supplier shall indemnify the purchaser against all third-party claims of infringement of patent, trademark, or industrial design rights arising from use of the goods or any part thereof by the purchaser.

6.2 When a supplier developed documentation / projects for the municipality / municipal entity, the intellectual, copy and patent rights or ownership of such documents or projects will vest in the municipality / municipal entity.

7. Performance security

7.1 Within thirty (30) days of receipt of the notification of contract award, the successful bidder shall furnish to the purchaser the performance security of the amount specified in SCC.

7.2 The proceeds of the performance security shall be payable to the purchaser as compensation for any loss resulting from the supplier's failure to complete his obligations under the contract.

7.3 The performance security shall be denominated in the currency of the contract, or in a freely convertible currency acceptable to the purchaser and shall be in one of the following forms: (a) a bank guarantee or an irrevocable letter of credit issued by a reputable bank located in the purchaser's country or abroad, acceptable to the purchaser, in the form provided in the bidding documents or another form acceptable to the purchaser; or (b) a cashier's or certified cheque.

7.4 The performance security will be discharged by the purchaser and returned to the supplier not later than thirty (30) days following the date of completion of the supplier's performance obligations under the contract, including any warranty obligations, unless otherwise specified.

8. Inspections, tests and analyses

8.1 All pre-bidding testing will be for the account of the bidder.

8.2 If it is a bid condition that goods to be produced or services to be rendered should at any stage be subject to inspections, tests and analyses, the bidder or contractor's premises shall be open, at all reasonable hours, for inspection by a representative of the purchaser or organization acting on behalf of the purchaser.

8.3 If there are no inspection requirements indicated in the bidding documents and no mention is made in the contract, but during the contract period it is decided that inspections shall be carried out, the purchaser shall itself make the necessary arrangements, including payment arrangements with the testing authority concerned.

8.4 If the inspections, tests and analyses referred to in clauses 8.2 and 8.3 show the goods to be in accordance with the contract requirements, the cost of the inspections, tests and analyses shall be defrayed by the purchaser.

8.5 Where the goods or services referred to in clauses 8.2 and 8.3 do not comply with the contract requirements, irrespective of whether such goods or services are accepted or not, the cost in connection with these inspections, tests or analyses shall be defrayed by the supplier.

8.6 Goods and services which are referred to in clauses 8.2 and 8.3 and which do not comply with the contract requirements may be rejected.

8.7 Any contract goods may on or after delivery be inspected, tested or analysed and may be rejected if found not to comply with the requirements of the contract. Such rejected goods shall be held at the cost and risk of the supplier who shall, when called upon, remove them immediately at his own cost and forthwith substitute them with goods, which do comply with the requirements of the contract. Failing such removal, the rejected goods shall be returned at the suppliers cost and risk. Should the supplier fail to provide the substitute goods forthwith, the purchaser may, without giving the supplier further opportunity to substitute the rejected goods, purchase such goods as may be necessary at the expense of the supplier.

8.8 The provisions of clauses 8.4 to 8.7 shall not prejudice the right of the purchaser to cancel the contract on account of a breach of the conditions thereof, or to act in terms of Clause 22 of GCC.

9. Packing

9.1 The supplier shall provide such packing of the goods as is required to prevent their damage or deterioration during transit to their final destination, as indicated in the contract. The packing shall be sufficient to withstand, without limitation, rough handling during transit and exposure to extreme temperatures, salt and precipitation during transit, and open storage. Packing, case size weights shall take into consideration, where appropriate, the remoteness of the goods' final destination and the absence of heavy handling facilities at all points in transit.

9.2 The packing, marking, and documentation within and outside the packages shall comply strictly with such special requirements as shall be expressly provided for in the contract, including additional requirements, if any, and in any subsequent instructions ordered by the purchaser.

- 10. Delivery and documents**
- 10.1 Delivery of the goods and arrangements for shipping and clearance obligations, shall be made by the supplier in accordance with the terms specified in the contract.
- 11. Insurance**
- 11.1 The goods supplied under the contract shall be fully insured in a freely convertible currency against loss or damage incidental to manufacture or acquisition, transportation, storage and delivery in the manner specified.
- 12. Transportation**
- 12.1 Should a price other than an all-inclusive delivered price be required, this shall be specified.
- 13. Incidental Services**
- 13.1 The supplier may be required to provide any or all of the following services, including additional services, if any:
- (a) performance or supervision of on-site assembly and/or commissioning of the supplied goods;
 - (b) furnishing of tools required for assembly and/or maintenance of the supplied goods;
 - (c) furnishing of a detailed operations and maintenance manual for each appropriate unit of the supplied goods;
 - (d) performance or supervision or maintenance and/or repair of the supplied goods, for a period of time agreed by the parties, provided that this service shall not relieve the supplier of any warranty obligations under this contract; and
 - (e) training of the purchaser's personnel, at the supplier's plant and/or on-site, in assembly, start-up, operation, maintenance, and/or repair of the supplied goods.
- 13.2 Prices charged by the supplier for incidental services, if not included in the contract price for the goods, shall be agreed upon in advance by the parties and shall not exceed the prevailing rates charged to other parties by the supplier for similar services.
- 14. Spare parts**
- 14.1 As specified, the supplier may be required to provide any or all of the following materials, notifications, and information pertaining to spare parts manufactured or distributed by the supplier:
- (a) such spare parts as the purchaser may elect to purchase from the supplier, provided that this election shall not relieve the supplier of any warranty obligations under the contract; and;
 - (b) in the event of termination of production of the spare parts: (i) advance notification to the purchaser of the pending termination, in sufficient time to permit the purchaser to procure needed requirements; and (ii) following such termination, furnishing at no cost to the purchaser, the blueprints, drawings, and specifications of the spare parts, if requested.
- 15. Warranty**
- 15.1 The supplier warrants that the goods supplied under the contract are new, unused, of the most recent or current models, and that they incorporate all recent improvements in design and materials unless provided otherwise in the contract. The supplier further warrants that all goods supplied under this contract shall have no defect, arising from design, materials, or workmanship (except when the design and/or material is required by the purchaser's specifications) or from any act or omission of the supplier, that may develop under normal use of the supplied goods in the conditions prevailing in the country of final destination.
- 15.2 This warranty shall remain valid for twelve (12) months after the goods, or any portion thereof as the case may be, have been delivered to and accepted at the final destination indicated in the contract, or for eighteen (18) months after the date of shipment from the port or place of loading in the source country, whichever period concludes earlier, unless specified otherwise.
- 15.3 The purchaser shall promptly notify the supplier in writing of any claims arising under this warranty.
- 15.4 Upon receipt of such notice, the supplier shall, within the period specified and with all reasonable speed, repair or replace the defective goods or parts thereof, without costs to the purchaser.
- 15.5 If the supplier, having been notified, fails to remedy the defect(s) within the period specified, the purchaser may proceed to take such remedial action as may be necessary, at the supplier's risk and expense and without prejudice to any other rights which the purchaser may have against the supplier under the contract.
- 16. Payment**
- 16.1 The method and conditions of payment to be made to the supplier under this contract shall be specified.
- 16.2 The supplier shall furnish the purchaser with an invoice accompanied by a copy of the delivery note and upon fulfillment of other obligations stipulated in the contract.
- 16.3 Payments shall be made promptly by the purchaser, but in no case later than thirty (30) days after submission of an invoice or claim by the supplier.
- 16.4 Payment will be made in Rand unless otherwise stipulated.
- 17. Prices**
- 17.1 Prices charged by the supplier for goods delivered and services performed under the contract shall not vary from the prices quoted by the supplier in his bid, with the exception of any price adjustments authorized or in the purchaser's request for bid validity extension, as the case may be.
- 18. Variation orders**
- 18.1 In cases where the estimated value of the envisaged changes in purchase does not vary more than 15% of the total value of the original contract, the contractor may be instructed to deliver the goods or render the services as such. In cases of measurable

quantities, the contractor may be approached to reduce the unit price, and such offers may be accepted provided that there is no escalation in price.

19. Assignment

19.1 The supplier shall not assign, in whole or in part, its obligations to perform under the contract, except with the purchaser's prior written consent.

20. Subcontracts

20.1 The supplier shall notify the purchaser in writing of all subcontracts awarded under this contracts if not already specified in the bid. Such notification, in the original bid or later, shall not relieve the supplier from any liability or obligation under the contract.

21. Delays in the supplier's performance

21.1 Delivery of the goods and performance of services shall be made by the supplier in accordance with the time schedule prescribed by the purchaser in the contract.

21.2 If at any time during performance of the contract, the supplier or its subcontractor(s) should encounter conditions impeding timely delivery of the goods and performance of services, the supplier shall promptly notify the purchaser in writing of the fact of the delay, its likely duration and its cause(s). As soon as practicable after receipt of the supplier's notice, the purchaser shall evaluate the situation and may at his discretion extend the supplier's time for performance, with or without the imposition of penalties, in which case the extension shall be ratified by the parties by amendment of contract.

21.3 The right is reserved to procure outside of the contract small quantities or to have minor essential services executed if an emergency arises, the supplier's point of supply is not situated at or near the place where the goods are required, or the supplier's services are not readily available.

21.4 Except as provided under GCC Clause 25, a delay by the supplier in the performance of its delivery obligations shall render the supplier liable to the imposition of penalties, pursuant to GCC Clause 22, unless an extension of time is agreed upon pursuant to GCC Clause 22.2 without the application of penalties.

21.5 Upon any delay beyond the delivery period in the case of a goods contract, the purchaser shall, without cancelling the contract, be entitled to purchase goods of a similar quality and up to the same quantity in substitution of the goods not supplied in conformity with the contract and to return any goods delivered later at the supplier's expense and risk, or to cancel the contract and buy such goods as may be required to complete the contract and without prejudice to his other rights, be entitled to claim damages from the supplier.

22. Penalties

22.1 Subject to GCC Clause 25, if the supplier fails to deliver any or all of the goods or to perform the services within the period(s) specified in the contract, the purchaser shall, without prejudice to its other remedies under the contract, deduct from the contract price, as a penalty, a sum calculated on the delivered price of the delayed goods or unperformed services using the current prime interest rate calculated for each day of the delay until actual delivery or performance. The purchaser may also consider termination of the contract pursuant to GCC Clause 23.

23. Termination for default

23.1 The purchaser, without prejudice to any other remedy for breach of contract, by written notice of default sent to the supplier, may terminate this contract in whole or in part:

(a) if the supplier fails to deliver any or all of the goods within the period(s) specified in the contract, or within any extension thereof granted by the purchaser pursuant to GCC Clause 21.2; (b) if the supplier fails to perform any other obligation(s) under the contract; or (c) if the supplier, in the judgement of the purchaser, has engaged in corrupt or fraudulent practices in competing for or in executing the contract.

23.2 In the event the purchaser terminates the contract in whole or in part, the purchaser may procure, upon such terms and in such manner, as it deems appropriate, goods, works or services similar to those undelivered, and the supplier shall be liable to the purchaser for any excess costs for such similar goods, works or services. However, the supplier shall continue performance of the contract to the extent not terminated.

23.3 Where the purchaser terminates the contract in whole or in part, the purchaser may decide to impose a restriction penalty on the supplier by prohibiting such supplier from doing business with the public sector for a period not exceeding 10 years.

23.4 If a purchaser intends imposing a restriction on a supplier or any person associated with the supplier, the supplier will be allowed a time period of not more than fourteen (14) days to provide reasons why the envisaged restriction should not be imposed. Should the supplier fail to respond within the stipulated fourteen (14) days the purchaser may regard the supplier as having no objection and proceed with the restriction.

23.5 Any restriction imposed on any person by the purchaser will, at the discretion of the purchaser, also be applicable to any other enterprise or any partner, manager, director or other person who wholly or partly exercises or exercised or may exercise control over the enterprise of the first-mentioned person, and with which enterprise or person the first-mentioned person, is or was in the opinion of the purchaser actively associated.

23.6 If a restriction is imposed, the purchaser must, within five (5) working days of such imposition, furnish the National Treasury, with the following information:

(i) the name and address of the supplier and / or person restricted by the purchaser;

(ii) the date of commencement of the restriction

(iii) the period of restriction; and

(iv) the reasons for the restriction. These details will be loaded in the National Treasury's central database of suppliers or persons prohibited from doing business with the public sector.

23.7 If a court of law convicts a person of an offence as contemplated in sections 12 or 13 of the Prevention and Combating of Corrupt Activities Act, No. 12 of 2004, the court may also rule that such person's name be endorsed on the Register for Tender Defaulters. When a person's name has been endorsed on the Register, the person will be prohibited from doing business with the public sector

for a period not less than five years and not more than 10 years. The National Treasury is empowered to determine the period of restriction and each case will be dealt with on its own merits. According to section 32 of the Act the Register must be open to the public. The Register can be perused on the National Treasury website

24. Antidumping and countervailing duties and rights

24.1 When, after the date of bid, provisional payments are required, or anti-dumping or countervailing duties are imposed, or the amount of a provisional payment or anti-dumping or countervailing right is increased in respect of any dumped or subsidized import, the State is not liable for any amount so required or imposed, or for the amount of any such increase. When, after the said date, such a provisional payment is no longer required or any such anti-dumping or countervailing right is abolished, or where the amount of such provisional payment or any such right is reduced, any such favourable difference shall on demand be paid forthwith by the supplier to the purchaser or the purchaser may deduct such amounts from moneys (if any) which may otherwise be due to the supplier in regard to goods or services which he delivered or rendered, or is to deliver or render in terms of the contract or any other contract or any other amount which may be due to him.

25. Force Majeure

25.1 Notwithstanding the provisions of GCC Clauses 22 and 23, the supplier shall not be liable for forfeiture of its performance security, damages, or termination for default if and to the extent that his delay in performance or other failure to perform his obligations under the contract is the result of an event of force majeure. 25.2 If a force majeure situation arises, the supplier shall promptly notify the purchaser in writing of such condition and the cause thereof. Unless otherwise directed by the purchaser in writing, the supplier shall continue to perform its obligations under the contract as far as is reasonably practical, and shall seek all reasonable alternative means for performance not prevented by the force majeure event.

26. Termination for insolvency

26.1 The purchaser may at any time terminate the contract by giving written notice to the supplier if the supplier becomes bankrupt or otherwise insolvent. In this event, termination will be without compensation to the supplier, provided that such termination will not prejudice or affect any right of action or remedy, which has accrued or will accrue thereafter to the purchaser.

27. Settlement of Disputes

27.1 If any dispute or difference of any kind whatsoever arises between the purchaser and the supplier in connection with or arising out of the contract, the parties shall make every effort to resolve amicably such dispute or difference by mutual consultation.

27.2 If, after thirty (30) days, the parties have failed to resolve their dispute or difference by such mutual consultation, then either the purchaser or the supplier may give notice to the other party of his intention to commence with mediation. No mediation in respect of this matter may be commenced unless such notice is given to the other party.

27.3 Should it not be possible to settle a dispute by means of mediation, it may be settled in a South African court of law.

27.4 Notwithstanding any reference to mediation and/or court proceedings herein, (a) the parties shall continue to perform their respective obligations under the contract unless they otherwise agree; and (b) the purchaser shall pay the supplier any monies due the supplier for goods delivered and / or services rendered according to the prescripts of the contract.

28. Limitation of Liability

28.1 Except in cases of criminal negligence or wilful misconduct, and in the case of infringement pursuant to Clause 6; (a) the supplier shall not be liable to the purchaser, whether in contract, tort, or otherwise, for any indirect or consequential loss or damage, loss of use, loss of production, or loss of profits or interest costs, provided that this exclusion shall not apply to any obligation of the supplier to pay penalties and/or damages to the purchaser; and (b) the aggregate liability of the supplier to the purchaser, whether under the contract, in tort or otherwise, shall not exceed the total contract price, provided that this limitation shall not apply to the cost of repairing or replacing defective equipment.

29. Governing language

29.1 The contract shall be written in English. All correspondence and other documents pertaining to the contract that is exchanged by the parties shall also be written in English.

30. Applicable law

30.1 The contract shall be interpreted in accordance with South African laws, unless otherwise specified.

31. Notices

31.1 Every written acceptance of a bid shall be posted to the supplier concerned by registered or certified mail and any other notice to him shall be posted by ordinary mail to the address furnished in his bid or to the address notified later by him in writing and such posting shall be deemed to be proper service of such notice.

31.2 The time mentioned in the contract documents for performing any act after such aforesaid notice has been given, shall be reckoned from the date of posting of such notice.

32. Taxes and duties

32.1 A foreign supplier shall be entirely responsible for all taxes, stamp duties, license fees, and other such levies imposed outside the purchaser's country.

32.2 A local supplier shall be entirely responsible for all taxes, duties, license fees, etc., incurred until delivery of the contracted goods to the purchaser.

32.3 No contract shall be concluded with any bidder whose tax matters are not in order. Prior to the award of a bid SARS must have certified that the tax matters of the preferred bidder are in order.

32.4 No contract shall be concluded with any bidder whose municipal rates and taxes and municipal services charges are in arrears.

33. Transfer of contracts

33.1 The contractor shall not abandon, transfer, cede assign or sublet a contract or part thereof without the written permission of the purchaser

34. Amendment of contracts

34.1 No agreement to amend or vary a contract or order or the conditions, stipulations or provisions thereof shall be valid and of any force unless such agreement to amend or vary is entered into in writing and signed by the contracting parties. Any waiver of the requirement that the agreement to amend or vary shall be in writing, shall also be in writing.

35. Prohibition of restrictive practices

35.1 In terms of section 4 (1) (b) (iii) of the Competition Act No. 89 of 1998, as amended, an agreement between, or concerted practice by, firms, or a decision by an association of firms, is prohibited if it is between parties in a horizontal relationship and if a bidder(s) is / are or a contractor(s) was / were involved in collusive bidding.

35.2 If a bidder(s) or contractor(s) based on reasonable grounds or evidence obtained by the purchaser has / have engaged in the restrictive practice referred to above, the purchaser may refer the matter to the Competition Commission for investigation and possible imposition of administrative penalties as contemplated in section 59 of the Competition Act No 89 Of 1998. 35.3 If a bidder(s) or contractor(s) has / have been found guilty by the Competition Commission of the restrictive practice referred to above, the purchaser may, in addition and without prejudice to any other remedy provided for, invalidate the bid(s) for such item(s) offered, and / or terminate the contract in whole or part, and / or restrict the bidder(s) or contractor(s) from conducting business with the public sector for a period not exceeding ten (10) years and / or claim damages from the bidder(s) or contractor(s) concerned.

SECTION 1.4: SPECIAL CONDITIONS OF TENDER

1.4.1 COMPANY AND ARTISAN REGISTRATIONS

1.4.1.1 Only contractors registered with NHBRC (National Home Builders Registration Council) will be considered. Proof of registration to be submitted. **Failure to submit proof with the tender document may be seen as submitting a non-responsive bid.**

1.4.1.2 Only CIDB 3GB Grading and higher Contractors are to be considered

1.4.2 QUOTATION AND PRICING

1.4.2.1 It will be expected from the Successful bidder to provide a quote on required work before any work commences, in the case of non-emergency work. All rates quoted should be in line with the offered rates but can't exceed the original quoted amount.

1.4.2.2 All prices should include supply, delivery, construction and installation and VAT (Value Added Tax).

1.4.2.3 Service Providers to allow for all indirect costs including Indemnity-, risk- and liability-insurances, cost of Foreman, admin and other supervision, cost of plant and equipment hire etc., and other Preliminary and General cost not listed.

1.4.3 PRODUCTS, MATERIALS AND COMPLIANCE

1.4.3.1 Indicating any similar approved products. If similar products to be used, it must be specified by the Contractor in the quotation document, failure to comply can lead to the elimination as preferred bidder.

1.4.3.2 All materials used to be SABS approved and installed according to the supplier specification and for the intended use only.

1.4.3.3 All works carried out or material supplied to conform to the South African National Standards.

1.4.4 PAYMENTS

1.4.4.1 Employer shall only pay the Contractor for works completed and in terms of the provision of the Contract.

1.4.4.2 The Contractor shall need to provide documentation for proof of ownership for any claim for Material on Site.

1.4.4.3 The Contractor needs to provide a statement which he/she considers due to him/her. The Employer Representative will issue a Payment Certificate and Payment Summary for Work completed if in agreement with the Contractor.

1.4.4.4 The original and signed Payment Certificate and Payment Summary must be handed in to Creditors section together with the Contractor invoice reflecting the amount as on the Payment Certificate. Documentation can be submitted via e-mail to creditors@mosselbay.gov.za or per hard copy at 101 Marsh Street, Mossel Bay.

1.4.4.5 Invoices will not be approved for payment if the Payment Certificate and Payment Summary are not provided and it remains the responsibility of the Contractor to ensure correct information is provided.

1.4.4.6 Payment of services/items will be done within thirty (30) days, after receipt of an official invoice or monthly statement.

- 1.4.5 A preferred and alternative bidder to be appointed depending on the responsiveness of bidders.
- 1.4.5.1 The successful bidder (preferred bidder) must confirm, in writing, within 48 hours after receipt of the order, that the required services can be rendered. Failure to respond or to make alternative arrangements with the relevant municipal official will result in cancellation of the order and the alternative bidder will be used.
- 1.4.5.2 The alternative bidder must confirm, in writing, within 48 hours after receipt of the order, that the required services can be rendered. Failure to respond or to make alternative arrangements with the relevant municipal official will result in cancellation of the order and will be deemed that the service cannot be rendered, and the relevant SCM process will be followed.

1.4.6 HEALTH AND SAFETY REQUIREMENTS

- 1.4.6.1 The Contractor to submit a Health and Safety Plan, as per the Occupational Health and Safety Act No. 85 of 1993, to the Municipal Health and Safety Officer for consideration for approval before work commences.
- 1.4.6.2 Pro Forma Risk Assessment form to be completed by the Contractor before work commences and kept on site at all times while carrying out the Contract Works, this form must be submitted to the Employer's Representative.
- 1.4.6.3 Penalty Fee for OHS Non-Compliance will amount to 10% of the Contract Value to the maximum of R2 000.00 including VAT. OHS Penalty Fee will be applicable per incident, per site, per day, per area, per works, per non-compliance incident. Penalty Fee issued by the Health and Safety Officer of the Client, will be deducted from the Payment Certificate issued for work completed.

1.4.7 SITE ESTABLISHMENT AND PROTECTION OF THE PUBLIC

- 1.4.7.1 No danger tape shall be used for barricading. Construction Signage must be visible to the public at all times. Construction Site and all excavations to be fenced off with rigid orange nylon netting.

1.4.8 SITE CLEARANCE AND CARTING AWAY

- 1.4.8.1 On Completion of the Works the Contractor shall clear away and remove from the Site all Construction Equipment, surplus material, rubbish and Temporary Works.
- 1.4.8.2 All building rubble to carted away to a legal dumping site.

1.4.9 NON- OR POOR PERFORMANCE

- 1.4.9.1 In the event of Non- or Poor Performance of Service Providers/Suppliers, it will be dealt with in terms of Section 43 of the SCM Policy.

1.4.10 Key Performance indicators

The following key performance indicators will be applicable to the successful bidder/s and will be measured after each order, to assess the performance:

- **Supplied in Terms of Specifications**

Standard	Service/product delivered complies with specifications set out in the tender document.
Target	Monthly
Proof of evidence	Site inspection reports

1.5 TENDER FUNCTIONALITY

- (a) Tenders will be pre-evaluated on the criteria as set out below. Bidders that score less than **60 out of 75 points** for this criterion will be regarded as non-responsive and will not be evaluated on price, B-BBEE and locality. Unclear, vague, fragmented or incomplete information provided will result in no points being allocated.
- (b) Bidders must ensure that relevant information is submitted. If information is not submitted or referred to as an attachment, no points will be awarded.
- (c) No information or documentary proof, relating to the tender functionality, will be requested after closure of the tender.
- (d) The following criteria will be used to calculate points for the functionality of tenders and bidders should ensure that they submit all information in order to be pre-evaluated on the criteria mentioned below:

Nr	CRITERIA	MAXIMUM POINTS
1	Company (or JV) Experience	20
2	References Related to that Experience	15
3	Key Site Staff & Personnel allocated/ reserved for this tender	20
4	Plant, Equipment, Tools & Machinery allocated/ reserved for this tender	20
TOTAL		75

Functionality criteria are further divided as follows and points will be awarded as indicated below:

Criterion 1: Company (or JV) Experience

- (a) A maximum of **20** points will be awarded at the sole discretion of the Municipality's Bid Evaluation Committee based on the information provided. Please note that this section refers to the Company's and its legacy firms past experience. Meaning this section takes into consideration that the company as an entity has gained relevant experience in the past and showcase that the company is in the business of said Scope of Works.
- (b) Relevant experience is defined as the accumulation of knowledge or skill that results from direct participation in relevant/similar events or activities and/or as determined by the Mossel Bay Municipality and/or professional consulting engineer where applicable.

Experience required: Successfully completed projects related to the Construction of buildings	Maximum points
A minimum 1 year but up to 2 years total relevant experience of the company	5
More than 2 years, but up to 5 years total relevant experience of the company.	10
More than 5 years total relevant experience of the company.	20

- (c) In order to claim points for the above, bidders must submit sufficient information as well as documentary proof of experience relating to **the construction of buildings by means of appointment letters and completion certificates-**
- (d) Points will only be awarded for relevant & completed experience obtained relevant to the Tender Scope of Works. To be able to gain points the Tenderer must submit proof that the company has obtained the relevant experience for this Tender's Scope of Works & Specifications, and not only parts thereof. If experience is listed, please ensure it is applicable and relevant to the whole of this Tender and not only to parts thereof, otherwise the Bidder will not be awarded the necessary points. **Bidders to provide enough experience to score the total points.**

NB: If no information is provided below OR referred to as an additional attachment NO POINTS WILL BE AWARDED.

Criterion 2: References related to Experience

Please note that this section refers to the Company's and its legacy firms' references related to the experience. It also takes into account that the references are related & relevant to the **Construction of Buildings**. Bidders must provide their references with the attached questionnaire (see attachment A), which have to be completed and signed by the references in order to obtain points.

Please note that points will not overlap, meaning points are awarded only once per reference/company/entity *per project experience*. Please refrain from submitting multiple references from the same company on the same project. Please note it is the duty of the Bidder to ensure that the references given are relevant to the Scope of Works.

Reference Scoring: A maximum of **15** points will be awarded at the sole discretion of the Municipality's Bid Evaluation Committee based on the information provided and will be split as follows:

- In order to claim points, bidders must submit, with the tender document, three questionnaires to which similar work has been provided.
- These questionnaires must be current/most recent, relevant and related to the Experience submitted.
- It is the bidder's responsibility to ensure that the details provided are correct, before submitting his tender, and that the references will be available and be able to provide additional feedback, if necessary.
- If the references are unable to validate, verify or provide additional information on the projects, no points will be awarded for that particular reference.
- 5 points will be awarded for each questionnaire, which is positive and relevant to the Scope of Works of this contract, subject to the final discretion of the Bid Evaluation Committee.

NB: If no reference questionnaires are attached NO POINTS WILL BE AWARDED. COMPLETION CERTIFICATES AND/OR APPOINTMENT LETTERS WILL NOT BE ACCEPTED FOR THIS CRITERIA.

ATTACHMENT A

Question to Reference	Reference's Response
1. Detail of the work that have been successfully completed (similar to this scope of work) Construction of Buildings (1 point)
2. Was the work completed within the contractual time frame? (1 point)	Yes No If No, please state why:
3. Was the work completed within the contract amount? (1 point)	Yes No If No, please state why:
4. Did the contractor comply with the Occupational Health & Safety regulations on site? (1 point)	Yes No If No, please state why:
5. In general were you satisfied with their performance - thus would you recommend them for this Tender considering all of above? (1 point)	Yes No If No, please state why:

.....
NAME OF REFERENCE

.....
SIGNATURE

.....
CONTACT PERSON & TELEPHONE NUMBER

.....
DATE

STAMP OF REFERENCE (if available)

Criterion 3: KEY SITE STAFF & PERSONNEL

- (a) A maximum of **20 points** will be awarded at the sole discretion of the Municipality's Bid Evaluation Committee based on the information provided and will be split as follows. Points will only be awarded once for each staff/personnel allocated to this Tender, no multiple scoring per person.
- (b) **NB: Please provide name of staff member in the space provided below. If no name is provided NO POINTS WILL BE AWARDED.**

Site Staff & Personnel Required:	Max points	Name of Staff member
<p>Contract Manager (min 8 hours per week)</p> <ul style="list-style-type: none"> Personally, responsible for the contract management of the project Must be allocated to this project and be overall responsible for the execution of the works and all associated project management. Must manage the Contract as a whole Must inspect and approve all works Responsible for Payment Certificates, and overall general Admin and all correspondence Must attend Project meetings and submit information timely as requested 	<p>1-5y = 1 points</p> <p>More than 5 -10y = 3 points</p> <p>More than 10y =5 points</p>	
<p>General Foreman: Construction Manager & Supervisor (min 40 hours / 5 days per week / full time on site)</p> <ul style="list-style-type: none"> Must be suitably skilled and have CV verifiable experience as foreman on Building projects. Must supervise the works full-time on site, the team / the workers and the correct use of all plant/machinery. Must be able to work with local labour. Must ensure all Codes & Standards specifications are met and carried out. Must be able to do setting-out & levelling. 	<p>1-5y = 2 points</p> <p>More than 5 -10y = 6 points</p> <p>More than 10y =10 points</p>	
<p>Skilled Artisan - Bricklayers (min 40 hours / 5 days per week / full time on site)</p> <ul style="list-style-type: none"> Must be suitably skilled and have CV verifiable experience working with building projects. must supervise the team / the workers and the correct use of all plant/machinery. must be able to work with local labour and assist with skills transfer. must ensure all remedial specifications are met and carried out. must be on site at all times. 	<p>1-5y = 1 points</p> <p>More than 5 -10y = 3 points</p> <p>More than 10y = 5 points</p>	
<p>Skilled Artisan - Carpenters (min 40 hours / 5 days per week / full time on site)</p> <ul style="list-style-type: none"> Must be suitably skilled and have CV verifiable experience working with building projects. must supervise the team / the workers and the correct use of all plant/machinery. must be able to work with local labour and assist with skills transfer. must ensure all remedial specifications are met and carried out. must be on site at all times. 	<p>1-5y = 1 points</p> <p>More than 5 -10y = 3 points</p> <p>More than 10y = 5 points</p>	
TOTAL	20	

- (c) In order to claim points for the above bidders must submit detailed Curriculum Vitae (CV) of each key personnel to be used/allocated for this Tender. **The staff or personnel listed above must currently be employed by the Bidder company, if not then a letter stating such intent to employ this person, including this person's signature of willingness & acceptance for the intended duration of the project.** CV experience listed of key staff must be relevant and current. Points can only be allocated once, meaning one-person-one-score, no multiple scoring. Please note the staff allocated to this Tender must be on-site and used for this Tender. If the person is unavailable during time of execution, he/she must be replaced with someone of equal or better value and experience and proof as per CV submitted.
- (d) NB: Relevant experience is defined as the accumulation of knowledge or skill that results from direct participation in relevant similar events or activities and/or as determined by the Mossel Bay Municipality and/or professional consulting engineer where applicable.

Criterion 4: PLANT, EQUIPMENT, TOOLS & MACHINERY

If the Bidder intend to use plant / tools / equipment other than those stipulated in the Tender Specifications the Bidder must qualify/declare this in their tender document, for the evaluation process. If nothing is qualified or declared, then those stipulated in the Tender Specifications are applicable to this Tender.

A maximum of **20 points** will be awarded based on the information provided.

	Equipment	Owned/ Intent to Rent / Hire (Maximum Points)
1.	LDV / Bakkie or truck	5
2.	Concrete mixer	5
3.	Compactor (Whacker)	5
4.	Wheelbarrows	1
5.	Levels	1
6.	Profiles	1
7.	Trowels	1
8.	Ray wood	1
	TOTAL	20

- (a) If the vehicle, LDV/ Bakkie or Truck, is owned by the bidder, proof of ownership (vehicle registration documentation) must be submitted.
- (b) If the vehicle, LDV/ Bakkie or Truck, will be rented, proof of the intention to lease it from the supplier, for the duration of the contract, must be submitted with the tender document.
- (c) This vehicle must be available for inspection at any given time or point. Roadworthy tests may be requested if vehicle is not in satisfactory condition.
- (d) Photos or insurance policy or any type of proof of ownership for the following equipment to be provided to score points:
 - Concrete Mixer
 - Compactor (Whacker)
 - Wheelbarrows, levels, profiles, trowels and ray wood.

- (e) Proof of the intention to lease it from the supplier, for the duration of the contract, must be submitted with the tender document for the equipment as mentioned in (d) above to be provided to score points

The documentation as required as stipulated under (a) - (e) above, must be submitted with the tender document. No points will be awarded if this documentation is not submitted.

The tenderer shall state below what vehicle will be available specifically for this Contract. The tenderer shall differentiate, if applicable, between vehicle immediately available, vehicle will be acquired or hired for the work should he be awarded the tender.

The tenderer shall state below what vehicle will be available specifically for this Contract. The tenderer shall differentiate, if applicable, between vehicle immediately available, vehicle will be acquired or hired for the work should he be awarded the tender.

If no information is provided below or referred to as an additional attachment **NO POINTS WILL BE AWARDED.**

PLANT / TOOLS / EQUIPMENT AVAILABLE AND ALLOCATED FOR THIS PROJECT

<p style="text-align: center;">DESCRIPTION (type, size, capacity and year of registration)</p>	<p style="text-align: center;">QUANTITY</p>	<p style="text-align: center;">REGISTRATION NUMBER (Applicable for plant/vehicles/trailers etc.)</p>

EQUIPMENT THAT ARE OWNED

DESCRIPTION (type, size, capacity etc)	QUANTITY	OWNED

EQUIPMENT THAT WILL BE HIRED

DESCRIPTION (type, size, capacity etc)	QUANTITY	SOURCE HIRE

1.6 JOINT VENTURES

The evaluation of functionality regarding a Consortium or Joint venture, will be performed as follows:

For company experience the evaluation is based on the experience of the partner with the highest/longest experience record.

For the evaluation of the project team, if applicable, at least one of the Project leaders must be an employee with the leading partner of the consortium or joint venture. The leading partner of the consortium or joint venture is determined by the shareholding regarding the liability, which is included in the consortium or joint venture agreement.

If required for the evaluation of the financial ratings, if not issued for the consortium or joint venture specifically, the rating of the leading partner will be use in the assessment.

The designated Project leaders, if applicable, may not be changed without the prior approval of the accounting officer or his/her nominated person once the bid was awarded.

SECTION 2.1: SCOPE OF WORK

- 2.1.1 The Municipality of Mossel Bay has identified the need for New Offices for the K9 Dog Unit on erf 2001, Extension 23, Mossel Bay Municipality
- 2.1.2 The exact extend of the work is indicated on the architectural drawings.
- 2.1.3 Storage of tools and material must be arranged with Mossel Bay Municipality after awarding of the contract.
- 2.1.4 The project will be implemented in the financial year 2025/2026 and will be funded by Grant funding

2.1.5 SITE LOCATION

Location of site as per below indicated with the yellow arrow: 34° 10' 51.87"S 022° 05' 58.04"E



2.1.6 DESCRIPTION OF SITE AND ACCESS

The project is in Extension 23, Mossel Bay at the SPCA premises. Work will mostly be conducted within the existing Dog Unit premises. Access to the site is at the entrance to the SPCA grounds.

2.1.7 PROJECT SCOPE OF WORK

- 2.1.7.1 The scope of work to be covered by this project is understood to comprise of the following:
- Civil works for site clearance and site establishment
 - Construction of a new brick-build office building of 135m², complete with pitched roof, internal dry walling and kitchen/toilet facilities.

2.1.7.2 The description of the scope of works of the contract must be viewed as merely an outline scope and shall not limit or bound the works to be performed under the contract

2.1.7.3 The tenderer shall refer to the tender drawings and notes for specific detail:

1.5.4.3.1	3260-B-01	Site Plan
1.5.4.3.2	3260-B-02	Ground Storey Plan
1.5.4.3.3	3260-B-03	Electrical Layout Plan
1.5.4.3.4	3260-B-04	Electrical Layout Plan
1.5.4.3.5	3260-B-05	Drainage and Sanitary Layout Plan
1.5.4.3.6	3260-B-06	Sections
1.5.4.3.7	3260-B-07	Elevations, Windows and Door Schedules
1.5.4.3.8	3260_B_05	Roof Plan

2.1.8 CONSTRUCTION PROGRAMME AND METHODS

The Contractor will be required to develop and maintain for the full duration of the contract, a works programme whose purpose will be to ensure the work is carried out and controlled in such a way that the contract is completed within the time stated in the tender or in the time extended by the Engineer in writing.

This programme shall be in the form of a bar chart or other time/activity form acceptable to the Engineer.

2.1.9 SITE FACILITIES AVAILABLE

2.1.9.1 SOURCE OF WATER SUPPLY AND SEWERAGE CONNECTION

The Contractor shall make his own arrangements with the relevant authorities and pay all cost involved in the provision of temporary water and sewerage connections.

2.1.9.2 SOURCE OF POWER SUPPLY

The Contractor must make all his own arrangements with the relevant authorities and pay all cost involved in the provision of temporary electrical connections.

2.1.9.3 LOCATION OF CAMP

The location of the Contractor's camp including the material storage areas must be in accordance with the EMP and will be subject to the Engineer's approval.

2.1.9.4 HOUSING FOR CONTRACTOR'S EMPLOYEES

No housing for labourers will be permitted on site. The Contractor is responsible for the housing and transporting of his employees.

2.1.10 SITE FACILITIES REQUIRED

2.1.10.1 No housing or site office is required for the Engineer

2.1.10.2 A triplicate site instruction book supplied by the Contractor to be used for site instructions shall at all times be kept on site

2.1.11 FEATURES REQUIRING SPECIAL ATTENTION

2.1.11.1 DEALING WITH WATER

The contractor is responsible for the control of stormwater from adjoining areas, the site and groundwater.

2.1.11.2 SECURITY

The Contractor shall take every precaution to ensure safety and to protect the works from theft and vandalism. The Contractor will be responsible for the safety and security of his personnel, materials on site and the works in general at all times.

2.1.12 MINIMUL DISTURBANCE TO ENVIRONMENT

2.1.12.1 GENERAL

The site and surrounding area to be kept clean from building rubble, waste etc. throughout the duration of the contract. Roads for transporting material shall be kept clean and dirt free on a daily basis.

2.1.12.2 POLLUTION

The Contractor shall at all times during the contract period take reasonable precautions to avoid pollution, noise or any other nuisance. The Contractor shall abide by the relevant regulations of the Local Authority.

It is imperative that the Contractor shall ensure that dust pollution is kept to an absolute minimum.

2.1.12.3 ACCESS TO PROPERTY

The Contractor shall organize the work and transport of construction plant and material in such a manner as to cause the least possible inconvenience to the occupants of the property affected by the construction.

2.1.12.4 SITE MAINTENANCE

Progressive and systematic finishing and tidying will form an essential part of this contract. Under no circumstances shall spoil, rubble, materials, equipment or unfinished operations be allowed to accumulate unnecessarily and in the event of this occurring, the Engineer shall have the right to withhold payment for as long is necessary with respect of the relevant works in the area concerned.

2.1.12.5 TESTING AND QUALITY CONTROL

The Contractor shall engage the services of an independent testing laboratory for the testing of materials and the quality testing of layer works, to ensure his work conforms to the specifications.

2.1.12.6 MAINTENANCE AND PROTECTION OF EXISTING SERVICES

During the works, all existing services including water mains, sewers and storm water, electricity transmission, telephone lines, cables and conduits whether in service or not shall be protected, supported and maintained to the satisfaction of the service authority or department concerned and the Engineer.

Hydrants under pressure, water main valve covers and manholes shall be kept unobstructed and accessible at all times.

2.1.13 EXTENSION OF TIME ARISING FROM ABNORMAL CLIMATIC CONDITIONS

The Contractor shall keep daily rainfall records and submit them to the Employer at every site meeting.

Delays on working days only (based on a five-day working week) will be taken into account for the extension of time, but the Contractor shall make provision in his programme of work for an expected delay of working days in caused by normal inclement weather, for which he will not receive any extension of time.

Extension of time during working days will be granted to the degree to which actual delays, as defined above, exceed the number of working days as mentioned above.

Should the Contractor wish to submit a claim for extension of time for the completion of the works due to the works being delayed by reason of exceptionally inclement weather he shall do so in writing and with the following details:

- The times work was stopped and recommended
- A motivation for the reason's construction could not continue, with reference to the agreed construction programme activities
- The circumstances surrounding any instruction by a third party to stop work due to inclement weather
- The Contractor shall submit to the Engineer claims for all times lost due to inclement weather within 21 working days of he claims day.
- A record of inclement weather will be kept and recorded at site meetings on a regular basis.

2.1.14 CONTACT DETAILS EMPLOYER REPRESENTATIVES

Asset Manager: Buildings: Dawie Zwiendelaar
Contact Number Office - 044 606 5150
Contact Number Cell phone – 082 419 2747
E-mail Address - dzwiendelaar@mosselbay.gov.za

Technician: Investment Properties: Wonga Malashe
Contact Number Office - 044 606 5145
Contact Number Cell phone – 078 992 9940
E-mail Address - wmalashe@mosselbay.gov.za

SECTION 2.2: CONDITIONS OF CONTRACT

2.2.1 Building agreement

Guidelines: The General Conditions of Contract for Construction Works, Third Edition (2025) published by the South African Institution of Civil Engineering, Private Bag X200, Halfway House, 1685, is applicable to this Contract and is Obtainable from www.saice.org.za.

The contractor is deemed to have referred to the above-mentioned documents for the full intent and meaning of each clause.

General: These clauses are hereinafter referred to by clause number and heading only. Where standard clauses or alternatives are not entirely applicable to this agreement such modifications, corrections or supplements as will apply are given under each relevant clause heading and such modifications, corrections or supplements shall take precedence notwithstanding anything contrary contained in the above-mentioned documents.

2.2.2 Contract specific data

The following contract specific data, referring to the General Conditions of Contract of Construction Works, Third Edition (2025) are applicable to this Contract:

2.2.2.1 Compulsory Data

- a) Clause 1.1.1.26 - The Pricing Strategy is Re-Measurement.
- b) Clause 5.1.1 and 5.8.1 - Working hours are only permitted on weekdays, Monday - Friday between 07h45 - 16h15. Non-Working days are on Saturday, Sundays and public holidays.
- c) Clause 5.3.1 - The documentation required before commencing with the works are:
 1. Health and Safety Plan | Health and Safer Risk Assessment (Refer to Clause 4.3).
 2. Initial Programme (Refer to Clause 5.6).
- d) Clause 5.3.2 - The time to submit the documentation required before commencement of Works is 14 days. Failure to provide acceptable documentation or any documentation within in the stipulated time, the Employer may terminate the Contract in terms of Clause 9.2, alternatively a reasonable penalty fee, determined by the Employer Representative, can be imposed on the Contractor.
- e) Clause 5.13.1 - The penalty for failing to complete the whole of works are 5% of the Contract Value per day.
- f) Clause 5.14.1 - The requirements for achieving Practical Completion are to be fit for the intended purpose and occupation without danger or undue inconvenience to the Employer.
- g) Clause 5.16.3 - The latent defects period is 12 months.

2.2.2.2 Optional data

- a) Clause 4.4.1 The Contractor shall not Subcontract more than 25% of the total Contract, unless approval is provided by the Employer.
- b) Clause 6.3 - Variation or Expansion of Works Orders shall be limited to 20% of the Contract Value to increase or decrease in any work included in this Contract.
- c) Clause 2.2.1 - The Contractor shall only take instructions from the Employer Representative for this Contract Works to carry out additional work.

SECTION 2.3: PRICING DATA (Bill of Quantities)

- 2.3.1** All items listed in the BOQ are in accordance with the proposed plan and are only for Tender purpose. It remains the sole responsibility of the prospective Bidder to familiarize himself with this tender and the work required before he prices.
- 2.3.2** The bill of quantities refers to the architects' plans, drawing nr 3260_B_01 to 3260_B_07.
- 2.3.3** Only a total amount for the complete project to be included.
- 2.3.4** The total price submitted in the Bill of Quantities must include supply, delivery, construction, installation and 15% VAT.
- 2.3.5** The bid will be evaluated based on the total cost of contract as indicated under the TOTAL AMOUNT.
- 2.3.6** Bidders are required to comply with the prescribed pricing schedule below. No pricing schedules other than the pricing schedule as stated will be accepted and failure to adhere to this section will be seen as submitting a non-responsive bid.
- 2.3.7** Bidders MUST submit a price for each line item in the pricing schedule to be considered for evaluation. Should the bidder fail to submit a price for each line item as stated, the bid will be seen as non-responsive. If no rate will be charged, please indicate it as N/A or R0.

BILL OF QUANTITIES FOR NEW OFFICES FOR THE K9 DOG UNIT

NO	DESCRIPTION	UNIT	QUANTITY	RATE	TOTAL PRICE (INCLUDING VAT)
1	SITE PREPARATION				R
1.1	Clear the site area, site establishment	site	1		
2	HEALTH AND SAFETY				R
2.1	Health and Safety Plan for Project	plan	1		
3	FOUNDATIONS				R
	Concrete foundations and foundation walls as per architect's plans	foundations	1		
4	SURFACE BED CONSTRUCTION / SLAB CONSTRUCTION				R
	Surface bed and concrete floors as per architect's plans	floor	1		
5	EXTERNAL FACADE				R
5.1	270mm Brick cavity wall	cavity walls	1		
5.2	External wall finishes	wall finishes	1		
5.3	Windows as per architect's plans	windows	13		
5.4	External Door as per architect's plans	door	1		
6	ROOF				R
6.1	Structural roof timbers, Metal Roof Sheeting, Insulation as per architect's plans	roof	1		

NO	DESCRIPTION	UNIT	QUANTITY	RATE	TOTAL PRICE (INCLUDING VAT)
6.2	Rainwater disposal - gutters and downpipes, fascias, barge boards as per architect's plans	rainwater disposal	1		
7	INTERNAL DIVISIONS				R
7.1	Walls, Dry Wall Partitions	walls	1		
7.2	Internal Doors	doors	8		
8	FLOOR FINISHES				R
	Floor finishes as per architect's plans	floor	1		
9	CEILINGS				R
	Ceilings as per architect's plans	ceiling	1		
10	FITTINGS AND FIXED FURNITURE				R
10.1	Kitchen as per architect's plans	kitchen	1		
TOTAL (EXCL VAT)					R
11	PLUS 10% CONTINGENCY ALLOWANCE (EXCL VAT)				R
TOTAL (EXCL VAT)					R
PLUS 15% VAT					R
TOTAL PRICE INCLUDING VAT					R

SECTION 3.1: MBD1: BID REQUIREMENTS FOR MOSSEL BAY MUNICIPALITY

PART A – INVITATION TO BID

INVITATION TO BID FOR REQUIREMENTS OF THE MOSSEL BAY MUNICIPALITY					
BID NUMBER	TDR147/2025/2026	CLOSING DATE	17 JULY 2026	CLOSING TIME	12h00
DESCRIPTION	CONSTRUCTION OF NEW OFFICES FOR THE K9 DOG UNIT ON ERF 2001, EXTENSION 23, MOSSEL BAY MUNICIPALITY				
THE SUCCESSFUL BIDDER WILL BE REQUIRED TO FILL IN AND SIGN A WRITTEN CONTRACT FORM (MBD7)					

ORIGINAL COMPLETED BID DOCUMENTS MAY BE **POSTED** TO REACH THE TENDER BOX BY CLOSING DATE TO:

**The Tender Box
Mossel Bay Municipality
P O Box 25
MOSSEL BAY
6500**

OR

ORIGINAL COMPLETED BID DOCUMENTS MAY BE **DEPOSITED** IN THE TENDER BOX BY CLOSING DATE AT:

**The Entrance of the Mossel Bay Municipality’s Town Hall
101 Marsh Street
MOSSEL BAY**

SUPPLIER INFORMATION	
NAME OF BIDDER	
POSTAL ADDRESS AND CODE	
STREET ADDRESS	
TELEPHONE NUMBER	
ALTERNATIVE NUMBER	
E-MAIL ADDRESS	

VAT REGISTRATION NUMBER			
TAX COMPLIANCE STATUS PIN			
CIDB REGISTRATION NUMBER (if applicable)			
A B-BBEE STATUS LEVEL VERIFICATION CERTIFICATE/SWORN AFFIDAVIT (FOR EME'S & QSE'S) MUST BE SUBMITTED IN ORDER TO QUALIFY FOR PREFERENCE POINTS FOR B-BBEE)			
B-BBEE STATUS LEVEL VERIFICATION CERTIFICATE	YES	NO	
B-BBEE STATUS LEVEL SWORN AFFIDAVIT	YES	NO	
ARE YOU THE ACCREDITED REPRESENTATIVE IN SOUTH AFRICA FOR THE GOODS/SERVICES/WORK OFFERED?	YES/NO (If YES, enclose proof)		
ARE YOU'RE A FOREIGN BASED SUPPLIER FOR THE GOODS/SERVICES/WORK OFFERED?	YES/NO (If YES, answer Part B)		
TOTAL NUMBER OF ITEMS OFFERED			
TOTAL BID PRICE	R		
SIGNATURE OF BIDDER			
DATE			
CAPACITY UNDER WHICH THIS BID IS SIGNED			
BIDDING PROCEDURE ENQUIRIES MAY BE DIRECTED TO:		TECHNICAL ENQUIRIES MAY BE DIRECTED TO:	
DEPARTMENT	SCM	DEPARTMENT	Planning and Economic Development
CONTACT PERSON	Mr Deslin Kohler	CONTACT PERSON	Mr Dawie Zwiendelaar
TELEPHONE NUMBER	(044) 606-5192	TELEPHONE NUMBER	606-5000 (Ext. 5150)
E-MAIL ADDRESS	dkohler@mosselbay.gov.za	E-MAIL ADDRESS	dzwiendelaar@mosselbay.gov.za

PART B – TERMS AND CONDITIONS FOR BIDDING

1. BID SUBMISSION:	
<p>1.1. BIDS MUST BE DELIVERED BY THE STIPULATED TIME TO THE CORRECT ADDRESS. LATE BIDS WILL NOT BE ACCEPTED FOR CONSIDERATION.</p> <p>1.2. ALL BIDS MUST BE SUBMITTED ON THE OFFICIAL FORMS PROVIDED – (NOT TO BE RE-TYPED) OR ONLINE</p> <p>1.3. THIS BID IS SUBJECT TO THE PREFERENTIAL PROCUREMENT POLICY FRAMEWORK ACT, THE PREFERENTIAL PROCUREMENT REGULATIONS AND ANY APPROPRIATE MUNICIPAL POLICY. THE GENERAL CONDITIONS OF CONTRACT (GCC) AND, IF APPLICABLE, ANY OTHER SPECIAL CONDITIONS OF CONTRACT.</p>	
2. TAX COMPLIANCE REQUIREMENTS	
<p>2.1 BIDDERS MUST ENSURE COMPLIANCE WITH THEIR TAX OBLIGATIONS.</p> <p>2.2 BIDDERS ARE REQUIRED TO SUBMIT THEIR UNIQUE PERSONAL IDENTIFICATION NUMBER (PIN) ISSUED BY SARS TO ENABLE THE ORGAN OF STATE TO VIEW THE TAXPAYER'S PROFILE AND TAX STATUS.</p> <p>2.3 APPLICATION FOR THE TAX COMPLIANCE STATUS (TCS) CERTIFICATE OR PIN MAY ALSO BE MADE VIA E-FILING. IN ORDER TO USE THIS PROVISION, TAXPAYERS WILL NEED TO REGISTER WITH SARS AS E-FILERS THROUGH THE WEBSITE WWW.SARS.GOV.ZA.</p> <p>2.4 FOREIGN SUPPLIERS MUST COMPLETE THE PRE-AWARD QUESTIONNAIRE IN PART B:3.</p> <p>2.5 BIDDERS MAY ALSO SUBMIT A PRINTED TCS CERTIFICATE TOGETHER WITH THE BID.</p> <p>2.6 IN BIDS WHERE CONSORTIA / JOINT VENTURES / SUB-CONTRACTORS ARE INVOLVED; EACH PARTY MUST SUBMIT A SEPARATE TCS CERTIFICATE / PIN / CSD NUMBER.</p> <p>2.7 WHERE NO TCS IS AVAILABLE BUT THE BIDDER IS REGISTERED ON THE CENTRAL SUPPLIER DATABASE (CSD), A CSD NUMBER MUST BE PROVIDED.</p>	
3. QUESTIONNAIRE TO BIDDING FOREIGN SUPPLIERS	
3.1. IS THE ENTITY A RESIDENT OF THE REPUBLIC OF SOUTH AFRICA (RSA)?	<input type="checkbox"/> YES <input type="checkbox"/> NO
3.2. DOES THE ENTITY HAVE A BRANCH IN THE RSA?	<input type="checkbox"/> YES <input type="checkbox"/> NO
3.3. DOES THE ENTITY HAVE A PERMANENT ESTABLISHMENT IN THE RSA?	<input type="checkbox"/> YES <input type="checkbox"/> NO
3.4. DOES THE ENTITY HAVE ANY SOURCE OF INCOME IN THE RSA?	<input type="checkbox"/> YES <input type="checkbox"/> NO
3.5. IS THE ENTITY LIABLE IN THE RSA FOR ANY FORM OF TAXATION?	<input type="checkbox"/> YES <input type="checkbox"/> NO
<p>IF THE ANSWER IS "NO" TO ALL OF THE ABOVE, THEN IT IS NOT A REQUIREMENT TO REGISTER FOR A TAX COMPLIANCE STATUS SYSTEM PIN CODE FROM THE SOUTH AFRICAN REVENUE SERVICE (SARS) AND IF NOT REGISTER AS PER 2.3 ABOVE.</p>	

SIGNATURE OF BIDDER:

CAPACITY UNDER WHICH THIS BID IS SIGNED:

DATE:

SECTION 4.1: MBD4: DECLARATION OF INTEREST

1. No bid will be accepted from persons in the service of the state*.
2. Any person, having a kinship with persons in the service of the state, including a blood relationship, may make an offer or offers in terms of this invitation to bid. In view of possible allegations of favoritism, should the resulting bid, or part thereof, be awarded to persons connected with or related to persons in service of the state, it is required that the bidder or their authorised representative declare their position in relation to the evaluating/adjudicating authority.
3. **In order to give effect to the above, the following questionnaire must be completed and submitted with the bid.**
4. **Bidders are required to declare any change in directorship or membership during the term of this tender should it have had an influence on the award of the bid.**

4.1	Full Name of Bidder OR his OR her representative	
4.2	Identity Number	
4.3	Position occupied in the Company (director, trustee, shareholder ²)	
4.4	Company Registration Number	
4.5	Tax Reference Number	
4.6	VAT Registration Number	
4.7 The names of all directors/trustees/shareholder's/member, their individual identity numbers and state employee numbers must be indicated in number 4, below.		
4.8 Are you presently in service of the state		YES/NO
4.8.1 If so, furnish particulars		
4.9 Have you been in the service of the state for the past twelve months?		YES/NO
4.9.1 If so, furnish particulars		
4.10 Do you have any relationship (family, friend, other) with persons in service of the state and who may be involved with the evaluation and or adjudication of this bid?		YES/NO
4.10.1 If so, furnish particulars		

4.11 Are you, aware of any relationship (family, friend, other) between a bidder and any persons in the service of the state and who may be involved with the evaluation and or adjudication of this bid?	YES/NO
4.11.1 If so, furnish particulars	
4.12 Are any of the company's directors, managers, principal shareholders, or stakeholders in service of the state?	YES/NO
4.12.1 If so, furnish particulars	
4.13 Are any spouse, child or parent of the company's directors, managers, principal shareholders, or stakeholders in service of the state?	YES/NO
4.13.1 If so, furnish particulars	
4.14 Do you or any of the directors, trustees, managers, principle shareholders, or stakeholders of this company have any interest in any other related companies or business whether or not they are bidding for this contract?	YES/NO
4.14.1 If so, furnish particulars	

*MSCM Regulations: "in the service of the state" means to be –

- (a) a member of –
 - (i) any municipal council;
 - (ii) any provincial legislature; or
 - (iii) the national Assembly or the national Council of provinces;
- (b) a member of the board of directors of any municipal entity;
- (c) an official of any municipality or municipal entity;
- (d) an employee of any national or provincial department, national or provincial public entity or constitutional institution within the meaning of the Public Finance Management Act, 1999 (Act No.1 of 1999);
- (e) a member of the accounting authority of any national or provincial public entity; or
- (f) an employee of Parliament or a provincial legislature.

SECTION 4.2: MBD5: DECLARATION FOR PROCUREMENT ABOVE R10 MILLION

For all procurement expected to exceed R10 million (VAT included), bidders must complete the following questionnaire:

4.2.1 Are you by law required to prepare annual financial statements for auditing?	YES/NO
4.2.1.1 If yes , submit audited annual financial statements for the past three years or since the date of establishment during the past three years.	
4.2.2 Do you have any outstanding undisputed commitments for municipal services towards a municipality or any service provider in respect of which payment is overdue for more than 30 days?	YES/NO
4.2.2.1 If no , this serves to certify that the bidder has no undisputed commitments for municipal services towards a municipality or other service provider in respect of which payment is overdue for more than 30 days.	
4.2.2.2 If yes , furnish particulars:	
4.2.3 Has any contract been awarded to you by an organ of state during the past five years, including particulars of any material non-compliance or dispute concerning the execution of such contract?	YES/NO
4.2.3.1 If yes , furnish particulars:	
4.2.4 Will any portion of goods or services to be sourced from outside the Republic and, if so, what portion and whether any portion of payment from the municipality is expected to be transferred out of the Republic?	YES/NO
4.2.3.1 If yes , furnish particulars:	

SECTION 4.3: MBD6.1: PREFERENCE POINTS CLAIM FORM IN TERMS OF THE PREFERENTIAL PROCUREMENT REGULATIONS, 2022.

This preference form must form part of all tenders invited. It contains general information and serves as a claim form for preference points for specific goals.

NB: BEFORE COMPLETING THIS FORM, TENDERERS MUST STUDY THE GENERAL CONDITIONS, DEFINITIONS AND DIRECTIVES APPLICABLE IN RESPECT OF THE TENDER AND PREFERENTIAL PROCUREMENT REGULATIONS, 2022

1. GENERAL CONDITIONS

1.1 The following preference point systems are applicable to invitations to tender:

- the 80/20 system for requirements with a Rand value of up to R50 000 000 (all applicable taxes included); and
- the 90/10 system for requirements with a Rand value above R50 000 000 (all applicable taxes included).

1.2 To be completed by the organ of state

- (a) The 90/10 or 80/20 preference point system will be applicable in this tender. The lowest (goods and services) / highest (sales and leases) acceptable tender will be used to determine the accurate system once tenders are received.

1.3 Points for this tender (even in the case of a tender for income-generating contracts) shall be awarded for:

- (a) Price; and
- (b) Specific Goals.

1.4 To be completed by the organ of state:

The maximum points for this tender are allocated as follows:

	POINTS	POINTS
PRICE	80	90
SPECIFIC GOALS	20	10
Total points for Price and SPECIFIC GOALS	100	100

1.5 Failure on the part of a tenderer to claim points for specific goals with the tender, will be interpreted to mean that preference points for specific goals are not claimed. The tenderer is however required to submit the proof or documentation required in terms of this specific goals. That documentation may be requested by the municipality.

1.6 The organ of state reserves the right to require of a tenderer, either before a tender is adjudicated or at any time subsequently, to substantiate any claim in regard to preferences, in any manner required by the organ of state.

2. DEFINITIONS

- (a) “**tender**” means a written offer in the form determined by an organ of state in response to an invitation to provide goods or services through price quotations, competitive tendering process or any other method envisaged in legislation;
- (b) “**price**” means an amount of money tendered for goods or services, and includes all applicable taxes less all unconditional discounts;
- (c) “**rand value**” means the total estimated value of a contract in Rand, calculated at the time of bid invitation, and includes all applicable taxes;
- (d) “**tender for income-generating contracts**” means a written offer in the form determined by an organ of state in response to an invitation for the origination of income-generating contracts through any method envisaged in legislation that will result in a legal agreement between the organ of state and a third party that produces revenue for the organ of state, and includes, but is not limited to, leasing and disposal of assets and concession contracts, excluding direct sales and disposal of assets through public auctions; and
- (e) “**the Act**” means the Preferential Procurement Policy Framework Act, 2000 (Act No. 5 of 2000).

3. FORMULAE FOR PROCUREMENT OF GOODS AND SERVICES

3.1. POINTS AWARDED FOR PRICE

3.1.1 THE 80/20 OR 90/10 PREFERENCE POINT SYSTEMS

A maximum of 80 or 90 points is allocated for price on the following basis:

$$\begin{array}{ccc} 80/20 & \text{or} & 90/10 \\ P_s = 80 \left(1 - \frac{P_t - P_{min}}{P_{min}} \right) & \text{or} & P_s = 90 \left(1 - \frac{P_t - P_{min}}{P_{min}} \right) \end{array}$$

Where

P_s = Points scored for price of tender under consideration

P_t = Price of tender under consideration

P_{min} = Price of lowest acceptable tender

3.2. FORMULAE FOR DISPOSAL OR LEASING OF STATE ASSETS AND INCOME GENERATING PROCUREMENT

3.2.1. POINTS AWARDED FOR PRICE

A maximum of 80 or 90 points is allocated for price on the following basis:

$$\begin{array}{ccc} 80/20 & \text{or} & 90/10 \\ P_s = 80 \left(1 + \frac{P_t - P_{max}}{P_{max}} \right) & \text{or} & P_s = 90 \left(1 + \frac{P_t - P_{max}}{P_{max}} \right) \end{array}$$

Where

P_s = Points scored for price of tender under consideration

- Pt = Price of tender under consideration
Pmax = Price of highest acceptable tender

4. POINTS AWARDED FOR SPECIFIC GOALS

4.1. In terms of Mossel Bay Preferential Procurement Policy, preference points must be awarded for specific goals stated in the tender. For the purposes of this tender the tenderer will be allocated points based on the goals stated in table 1 below as may be supported by proof/ documentation stated in the conditions of this tender:

4.2. In cases where organs of state intend to use Regulation 3(2) of the Regulations, which states that, if it is unclear whether the 80/20 or 90/10 preference point system applies, an organ of state must, in the tender documents, stipulate in the case of—

(a) an invitation for tender for income-generating contracts, that either the 80/20 or 90/10 preference point system will apply and that the highest acceptable tender will be used to determine the applicable preference point system; or

(b) any other invitation for tender, that either the 80/20 or 90/10 preference point system will apply and that the lowest acceptable tender will be used to determine the applicable preference point system,

then the organ of state must indicate the points allocated for specific goals for both the 90/10 and 80/20 preference point system.

Table 1: Specific goals for the tender and points claimed are indicated per the table below.

(Note to organs of state: Where either the 90/10 or 80/20 preference point system is applicable, corresponding points must also be indicated as such.

Note to tenderers: The tenderer must indicate how they claim points for each preference point system.

4.3. 50% of the 20/10 points will be allocated to promote this goal and points will be allocated in terms of the B-BBEE scorecard as follows.

B-BBEE Status Level of Contributor	Number of Points for Preference (80/20)	50% of Points for Preference
1	20	10
2	18	9
3	14	7
4	12	6
5	8	4
6	6	3
7	4	2
8	2	1
Non-compliant contributor	0	0

B-BBEE Status Level of Contributor	Number of Points for Preference (90/10)	50% of Points for Preference
1	10	5
2	9	4.50
3	6	3
4	5	2.50
5	4	2
6	3	1.50
7	2	1
8	1	0.50
Non-compliant contributor	0	0

- (a) A tenderer must submit proof of its B-BBEE status level contributor [scorecard].
(b) A tenderer failing to submit proof of B-BBEE status level of contributor may only score in terms of the 80/90-point formula for price; and scores 0 points for B-BBEE status level of contributor.

4.3.1 B-BBEE STATUS LEVEL OF CONTRIBUTOR CLAIMED IN TERMS OF PARAGRAPHS 4.1

B-BBEE Status Level of Contributor :

(Only indicate your B-BBEE Status Level of Contributor – the points will be calculated by the Municipality)

4.4. Points for specific goals to promote suppliers or service providers located in a province, district, or municipal area / (hereafter referred to as locality)

- (a) Each tender must specify in the invitation to tender that a maximum of 50% of the 20/10 points will be allocated to promote the specific goal of locality.
(b) Only one of the points as set out below that best describes the enterprise’s locality may be awarded if applicable.

No	Requirement	Points for enterprises within the Mossel Bay municipal area	Points for enterprises within the Garden Route District region	Points for enterprises within the Western Cape Province and other Provinces
1	Procurement under the 80/20 preference points system where the supplier or service provider is located in:	10	6	4

2	Procurement under the 90/10 preference points system where the supplier or service provider is located in:	5	3	2
---	--	---	---	---

- (c) Bidders must submit one of the following in order to receive points for the abovementioned criterion.
- (i) Municipal Account of bidder's address as indicated in bid document;
 - (ii) If the address as indicated in bid document is not in the name of the bidder, the latest lease agreement for this address or sworn affidavit from the registered owner of the property stating occupancy by the bidder is required.
 - (iii) The business address of the bidder as indicated in the MBD6.1 of the bid document as the business premises should be established/leased prior to the advertisement date.
 - (iv) Only fully operational business premises will be accepted. All vacant erven, storage units and postal addresses do not qualify as a business premises.

4.4.1 LOCALITY CLAIMED IN TERMS OF PARAGRAPHS 4.4

Locality (indicate as per table above) :

(The address provided in 4.5 below, will be used to determine the locality as per 4.4 above)

4.5. MUNICIPAL INFORMATION

Municipality where business is situated :

Registered Account Number :

Stand Number :

DECLARATION WITH REGARD TO COMPANY/FIRM

4.6. Name of company/firm.....

4.7. Company registration number:

4.8. TYPE OF COMPANY/ FIRM

- Partnership/Joint Venture / Consortium
- One-person business/sole propriety
- Close corporation
- Public Company
- Personal Liability Company
- (Pty) Limited
- Non-Profit Company
- State Owned Company

[TICK APPLICABLE BOX]

4.9. I, the undersigned, who is duly authorised to do so on behalf of the company/firm, certify that the points claimed, based on the specific goals as advised in the tender, qualifies the company/ firm for the preference(s) shown and I acknowledge that:

- i) The information furnished is true and correct;
- ii) The preference points claimed are in accordance with the General Conditions as indicated in paragraph 1 of this form;
- iii) In the event of a contract being awarded as a result of points claimed as shown in paragraphs 1.4 and 4.2, the contractor may be required to furnish documentary proof to the satisfaction of the organ of state that the claims are correct;
- iv) If the specific goals have been claimed or obtained on a fraudulent basis or any of the conditions of contract have not been fulfilled, the organ of state may, in addition to any other remedy it may have –
 - (a) disqualify the person from the tendering process;
 - (b) recover costs, losses or damages it has incurred or suffered as a result of that person's conduct;
 - (c) cancel the contract and claim any damages which it has suffered as a result of having to make less favourable arrangements due to such cancellation;
 - (d) recommend that the tenderer or contractor, its shareholders, and directors, or only the shareholders and directors who acted on a fraudulent basis, be restricted from obtaining business from any organ of state for a period not exceeding 10 years, after the *audi alteram partem* (hear the other side) rule has been applied; and
 - (e) forward the matter for criminal prosecution, if deemed necessary.

WITNESSES	
1.
2.

.....	
SIGNATURE(S) OF BIDDERS(S)	
DATE:
ADDRESS:

SECTION 4.4: MUNICIPAL RATES AND TAXES

Names of Directors/Partners/Senior Managers	Physical residential address of the Directors/Partners/Senior Managers	Residential Municipal Account number(s)	Name of Municipality

*Documentation as indicated in Section 1.2.8.2 must be submitted with the tender document.

DECLARATION

I, THE UNDERSIGNED (NAME and SURNAME)

CERTIFY THAT THE INFORMATION FURNISHED ABOVE IS CORRECT. I ACCEPT THAT THE STATE MAY ACT AGAINST ME SHOULD THIS DECLARATION PROVE TO BE FALSE.

.....
Signature

.....
Date

.....
Position

.....
Name of Bidder

SECTION 4.5: AUTHORITY FOR SIGNATORY

We, the undersigned, hereby authorize Mr/Mrs.....
acting in his/her capacity as
of the business trading as
to sign all documentation in connection with

NAME OF MEMBERS/DIRECTORS	SIGNATURE	DATE

Note: If bidders attach a copy of their Authorised Signatory as per Section 1.2.9 of the tender document, it is not necessary to complete this form.

“If a bidder is a sole proprietor, it is not required to complete this form, provided that the tender document was completed and signed by the owner.”

SECTION 4.6: MBD8: DECLARATION OF BIDDER'S PAST SUPPLY CHAIN MANAGEMENT PRACTICES

1. This Municipal Bidding Document must form part of all bids invited.
2. It serves as a declaration to be used by municipalities and municipal entities in ensuring that when goods and services are being procured, all reasonable steps are taken to combat the abuse of the supply chain management system.
3. The bid of any bidder may be rejected if that bidder, or any of its directors have:
 - a. abused the municipality's / municipal entity's supply chain management system or committed any improper conduct in relation to such system;
 - b. been convicted for fraud or corruption during the past five years;
 - c. wilfully neglected, reneged on, or failed to comply with any government, municipal or other public sector contract during the past five years; or
 - d. been listed in the Register for Tender Defaulters in terms of section 29 of the Prevention and Combating of Corrupt Activities Act (No 12 of 2004).
4. In order to give effect to the above, the following questionnaire must be completed and submitted with the bid.

Item	Question	Yes	No
4.1	<p>Is the bidder or any of its directors listed on the National Treasury's database as a company or person prohibited from doing business with the public sector?</p> <p>(Companies or persons who are listed on this database were informed in writing of this restriction by the National Treasury after the audi alteram partem rule was applied).</p> <p>The Database of Restricted Suppliers now resides on the National Treasury's website(www.treasury.gov.za) and can be accessed by clicking on its link at the bottom of the home page.</p>	Yes <input type="checkbox"/>	No <input type="checkbox"/>
4.1.1	If so, furnish particulars:		
4.2	<p>Is the bidder or any of its directors listed on the Register for Tender Defaulters in terms of section 29 of the Prevention and Combating of Corrupt Activities Act (No 12 of 2004)?</p> <p>The Register Tender Defaulters can be accessed on the National Treasury's website (www.treasury.gov.za) by clicking on its link at the bottom of the home page.</p>	Yes <input type="checkbox"/>	No <input type="checkbox"/>
4.2.1	If so, furnish particulars:		
4.3	Was the bidder or any of its directors convicted by a court of law (including a court of law outside the Republic of South Africa) for fraud or corruption during the past five years?	Yes <input type="checkbox"/>	No <input type="checkbox"/>

4.3.1	If so, furnish particulars:		
4.4	Does the bidder or any of its directors owe any municipal rates and taxes or municipal charges to the municipality / municipal entity, or to any other municipality / municipal entity, that is in arrears for more than three months?	Yes <input type="checkbox"/>	No <input type="checkbox"/>
4.4.1	If so, furnish particulars:		
4.5	Was any contract between the bidder and the municipality / municipal entity or any other organ of state terminated during the past five years on account of failure to perform on or comply with the contract?	Yes <input type="checkbox"/>	No <input type="checkbox"/>
4.5.1	If so, furnish particulars:		

CERTIFICATION

I, THE UNDERSIGNED (FULL NAME)CERTIFY THAT THE INFORMATION FURNISHED ON THIS DECLARATION FORM TRUE AND CORRECT.

I ACCEPT THAT, IN ADDITION TO CANCELLATION OF A CONTRACT, ACTION MAY BE TAKEN AGAINST ME SHOULD THIS DECLARATION PROVE TO BE FALSE.

.....
Signature

.....
Date

.....
Position

.....
Name of Bidder

SECTION 4.7: MBD9: CERTIFICATE OF INDEPENDENT BID DETERMINATION

1. This Municipal Bidding Document (MBD) must form part of all bids¹ invited.
2. Section 4 (1) (b) (iii) of the Competition Act No. 89 of 1998, as amended, prohibits an agreement between, or concerted practice by, firms, or a decision by an association of firms, if it is between parties in a horizontal relationship and if it involves collusive bidding (or bid rigging). ² Collusive bidding is a *pe se* prohibition meaning that it cannot be justified under any grounds.
3. Municipal Supply Regulation 38 (1) prescribes that a supply chain management policy must provide measures for the combating of abuse of the supply chain management system, and must enable the accounting officer, among others, to:
 - a. take all reasonable steps to prevent such abuse;
 - b. reject the bid of any bidder if that bidder or any of its directors has abused the supply chain management system of the municipality or municipal entity or has committed any improper conduct in relation to such system; and
 - c. cancel a contract awarded to a person if the person committed any corrupt or fraudulent act during the bidding process or the execution of the contract.
4. This MBD serves as a certificate of declaration that would be used by institutions to ensure that, when bids are considered, reasonable steps are taken to prevent any form of bid-rigging.
5. In order to give effect to the above, the attached Certificate of Bid Determination (MBD9) must be completed and submitted with the bid:

¹ Includes price quotations, advertised competitive bids, limited bids and proposals.

² Bid rigging (or collusive bidding) occurs when businesses, that would otherwise be expected to compete, secretly conspire to raise prices or lower the quality of goods and / or services for purchasers who wish to acquire goods and / or services through a bidding process. Bid rigging is, therefore, an agreement between competitors not to compete.

CERTIFICATE OF INDEPENDENT BID DETERMINATION

I, the undersigned, in submitting the accompanying bid:

**TDR147/2025/2026: CONSTRUCTION OF NEW OFFICES FOR THE K9 DOG UNIT ON ERF 2001, EXTENSION 23,
MOSSEL BAY MUNICIPALITY**

in response to the invitation for the bid made by:

MOSSEL BAY MUNICIPALITY

(Name of Municipality / Municipal Entity)

do hereby make the following statements that I certify to be true and complete in every respect:

I certify, on behalf of: _____ that:

(Name of Bidder)

1. I have read and I understand the contents of this Certificate;
2. I understand that the accompanying bid will be disqualified if this Certificate is found not to be true and complete in every respect;
3. I am authorized by the bidder to sign this Certificate, and to submit the accompanying bid, on behalf of the bidder;
4. Each person whose signature appears on the accompanying bid has been authorized by the bidder to determine the terms of, and to sign, the bid, on behalf of the bidder;
5. For the purposes of this Certificate and the accompanying bid, I understand that the word "competitor" shall include any individual or organization, other than the bidder, whether or not affiliated with the bidder, who:
 - (a) has been requested to submit a bid in response to this bid invitation;
 - (b) could potentially submit a bid in response to this bid invitation, based on their qualifications, abilities or experience; and
 - (c) provides the same goods and services as the bidder and/or is in the same line of business as the bidder
6. The bidder has arrived at the accompanying bid independently from, and without consultation, communication, agreement or arrangement with any competitor. However, communication between partners in a joint venture or consortium³ will not be construed as collusive bidding.
7. In particular, without limiting the generality of paragraphs 6 above, there has been no consultation, communication, agreement or arrangement with any competitor regarding:
 - (a) prices;
 - (b) geographical area where product or service will be rendered (market allocation)
 - (c) methods, factors or formulas used to calculate prices;

- (d) the intention or decision to submit or not to submit, a bid;
- (e) the submission of a bid which does not meet the specifications and conditions of the bid; or
- (f) bidding with the intention not to win the bid.

8. In addition, there have been no consultations, communications, agreements or arrangements with any competitor regarding the quality, quantity, specifications and conditions or delivery particulars of the products or services to which this bid invitation relates.
9. The terms of the accompanying bid have not been, and will not be, disclosed by the bidder, directly or indirectly, to any competitor, prior to the date and time of the official bid opening or of the awarding of the contract.
10. I am aware that, in addition and without prejudice to any other remedy provided to combat any restrictive practices related to bids and contracts, bids that are suspicious will be reported to the Competition Commission for investigation and possible imposition of administrative penalties in terms of section 59 of the Competition Act No. 89 of 1998 and or may be reported to the National Prosecuting Authority (NPA) for criminal investigation and or may be restricted from conducting business with the public sector for a period not exceeding ten (10) years in terms of the Prevention and Combating of Corrupt Activities Act No. 12 of 2004 or any other applicable legislation.

.....
Signature

.....
Date

.....
Position

.....
Name of Bidder

³ Joint venture or Consortium means an association of persons for the purpose of combining their expertise, property, capital, efforts, skill and knowledge in an activity for the execution of a contract.

SECTION 5: DECLARATION

1. I hereby declare that I have read, understood, agree and comply with all of the sections below, if included, that it shall be deemed to form and be construed as part of this agreement:

- (i) Bidding documents, viz
 - Invitation to bid;
 - Tax Compliance Status Pin;
 - Pricing schedule(s);
 - Technical Specification(s);
 - Preference claims for Broad Based Black Economic Empowerment Status Level of Contribution in terms of the Preferential Procurement Regulations;
 - Points claims in terms of specific goals for locality;
 - Declaration of interest;
 - Declaration of bidder's past SCM practices;
 - Certificate of Independent Bid Determination
 - Special Conditions of Contract;
- (ii) General Conditions of Contract; and
- (iii) Other (specify)

2. I confirm that I am duly authorised to sign this document.

NAME (PRINT)

CAPACITY

SIGNATURE

NAME OF FIRM

DATE

WITNESSES	
1
2.
DATE:

SECTION 6.1: MBD7.1: CONTRACT FORM: PART 1 (TO BE COMPLETED BY THE BIDDER)

BOTH THE SERVICE PROVIDER/SUPPLIER (PART 1) AND THE PURCHASER/LESSEE (PART 2) MUST FILL THIS FORM IN DUPLICATE. BOTH FORMS MUST BE SIGNED IN THE ORIGINAL SO THAT THE SERVICE PROVIDER/SUPPLIER AND THE PURCHASER/LESSEE WOULD BE IN POSSESSION OF ORIGINALLY SIGNED CONTRACTS FOR THEIR RESPECTIVE RECORDS.

1. The following documents shall be deemed to form and be read and construed as part of this agreement:

- (i) Bidding documents, viz
 - Invitation to bid;
 - Tax Compliance Status Pin;
 - Pricing schedule(s);
 - Technical Specification(s);
 - Preference claims for Broad Based Black Economic Empowerment Status Level of Contribution in terms of the Preferential Procurement Regulations;
 - Points claims in terms of specific goals for locality;
 - Declaration of interest;
 - Declaration of bidder's past SCM practices;
 - Certificate of Independent Bid Determination
 - Special Conditions of Contract;
- (ii) General Conditions of Contract; and
- (iii) Other (specify)

2. I confirm that I have satisfied myself as to the correctness and validity of my bid; that the price(s) and rate(s) quoted cover all the goods and/or works specified in the bidding documents; that the price(s) and rate(s) cover all my obligations and I accept that any mistakes regarding price(s) and rate(s) and calculations will be at my own risk.

I accept full responsibility for the proper execution and fulfilment of all obligations and conditions devolving on me under this agreement as the principal liable for the due fulfilment of this contract.

3. I declare that I have no participation in any collusive practices with any bidder or any other person regarding this or any other bid.

4. I confirm that I am duly authorised to sign this contract.

NAME (PRINT)

CAPACITY

SIGNATURE

NAME OF FIRM

DATE

WITNESSES	
1
2.
DATE:	

SECTION 6.2: FORM OF OFFER AND ACCEPTANCE

OFFER

The Employer, identified in the Acceptance signature block, has solicited offers to enter into a contract in respect of the following works:

TDR147/2025/2026: CONSTRUCTION OF NEW OFFICES FOR THE K9 DOG UNIT ON ERF 2001, EXTENSION 23, MOSSEL BAY MUNICIPALITY

The Tenderer, identified in the Offer signature block, below has examined the documents listed in the Tender Data and addenda thereto as listed in the Tender Schedules, and by submitting this Offer has accepted the Conditions of Tender.

By the representative of the Tenderer, deemed to be duly authorised, signing this part of this Form of Offer and Acceptance, the Tenderer offers to perform all of the obligations and liabilities of the Contractor under the Contract including compliance with all its terms and conditions according to their true intent and meaning for an amount to be determined in accordance with the Conditions of Contract identified in the Contract Data.

THE OFFERED TOTAL OF THE PRICES INCLUSIVE OF VALUED ADDED TAX IS:

R.....Various rates.....(in figures);

.....Various rates(in words).

This Offer may be accepted by the Employer by signing the Acceptance part of this Form of Offer and Acceptance and returning one copy of this document to the Tenderer before the end of the period of validity stated in the Tender Data, whereupon the Tenderer becomes the party named as the Contractor in the Conditions of Contract identified in the Contract Data.

Signature(s).....

Name(s).....

Capacity.....

For the tenderer.....

.....
(Name and address of organisation)

Name & signature of witness..... Date.....

ACCEPTANCE

By signing this part of this Form of Offer and Acceptance, the Employer identified below accepts the bidder’s Offer. In consideration thereof, the Employer shall pay the Contractor the amount due in accordance with the conditions of contract identified in the Contract Data. Acceptance of the bidder’s Offer shall form an agreement between the Employer and the bidder upon the terms and conditions contained in this agreement and in the contract that is the subject of this agreement

The terms of the contract, are contained in:

- Part C1 Agreements and Contract Data, (which includes this Form of Offer and Acceptance)
- Part C2 Pricing Data
- Part C3 Scope of Work: Works Information

and drawings and documents (or parts thereof), which may be incorporated by reference into the above listed Parts.

Deviations from and amendments to the documents listed in the Tender Data and any addenda thereto listed in the Returnable Schedules as well as any changes to the terms of the Offer agreed by the bidder and the Employer during this process of offer and acceptance, are contained in the Schedule of Deviations attached to and forming part of this Form of Offer and Acceptance. No amendments to or deviations from said documents are valid unless contained in this Schedule.

Deviations from and amendments to the draft contract as well as any changes to the terms of the Offer agreed by the bidder and the Employer during this process of offer and acceptance, are contained in the Schedule of Deviations attached to and forming part of this Form of Offer and Acceptance. No amendments to or deviations from said documents are valid unless contained in this Schedule.

Notwithstanding anything contained herein, this agreement comes into effect on the date when the bidder receives one fully completed original copy of this document, including the Schedule of Deviations (if any). Unless the bidder (now **contractor**) within five working days of the date of such receipt notifies the Employer in writing of any reason why he cannot accept the contents of this agreement, this agreement shall constitute a binding contract between the Parties.

Signature(s)

Name(s)

Capacity

for the employer

Name and address of organisation.....

.....

Name and signature of witness Date.....

Schedule of Deviations

The extent of deviations from the tender documents issued by the Employer prior to the tender closing date is limited to those permitted in terms of the Tender Data and the Conditions of Tender.

A Bidder's covering letter will not necessarily be included in the final contract document. Should any matter in such letter, which constitutes a deviation as aforesaid becomes the subject of agreements reached during the process of offer and acceptance; the outcome of such agreement shall be recorded here.

Any other matters arising from the process of offer and acceptance either as a confirmation, clarification or change to the tender documents and which it is agreed by the Parties becomes an obligation of the contract shall also be recorded here.

Any change or addition to the tender documents arising from the above agreements and recorded here shall also be incorporated into the final draft of the Contract.

- 1 Subject
- Details
-
- 2 Subject
- Details
-
- 3 Subject
- Details
-
- 4 Subject
- Details
-
- 5 Subject
- Details
-

By the duly familiarized representatives signing this agreement, the Employer and the bidder agree to and accept the foregoing schedule of deviations as the only deviations from and amendments to the documents listed in the tender data and addenda thereto as listed in the tender schedules, as well as any confirmation, clarification or changes to the terms of the offer agreed by the bidder and the employer during this process of offer and acceptance.

It is expressly agreed that no other matter whether in writing, oral communication or implied during the period between the issue of the tender documents and the receipt by the bidder of a completed signed copy of this Agreement shall have any meaning or effect in the contract between the parties arising from this agreement.

SECTION 6.4: THE RESOLUTION TAKEN BY THE BOARD OF DIRECTORS OF A JOINT VENTURE

RESOLUTION of a meeting of the Board of Directors / Members / Partners of

NAME OF TENDERER (Must agree with bidder details)

Held at _____ on _____
(Place) (Date)

RESOLVED THAT:

1. The enterprise submits a Tender to Mossel Bay Municipality in respect of the following:

TDR147/2025/2026: CONSTRUCTION OF NEW OFFICES FOR THE K9 DOG UNIT ON ERF 2001, EXTENSION 23, MOSSEL BAY MUNICIPALITY

(list all the legally correct full names and registration numbers, if applicable, of the Enterprises forming the Joint Venture).

_____ and

_____ and

_____ and

_____ and

_____ and

_____ and

2. Mr./Mrs./Ms. _____

In his/her capacity as _____

and who will sign as follows: _____

(SPECIMEN SIGNATURE)

be, and is hereby, authorised to sign the Tender and all other documents and/or correspondence in connection with and relating to the Tender, as well as to sign any contract, and or all documentation resulting from the award of the Tender to the **Joint Venture** enterprise mentioned above.

3. The enterprise in the form of a joint venture accept jointly and several liability, with parties under item 1 above for the fulfilment of the obligations of the joint venture deriving from, and in any way connected with the contract to be entered with the Mossel Bay Municipality in respect of the project described above under item 1.
4. The **Joint Venture** enterprise chooses as its domicilium citandi et executandi for all purposes arising from the joint venture agreement and contract with the Mossel Bay Municipality in respect of the project under item 1:

(Physical Address) _____

Note: The resolution **must be signed by all directors or members / partners** of the bidding enterprise. Should the space provided below not be enough for all the directors to sign, please provide a separate sheet in the same format below:

NB: **COMPULSARY TO BE COMPLETED** IN CASE OF JOINT VENTURE

	NAME	ID NUMBER	DIRECTORS/OWNERS PERSONAL TAX NO	SIGNATURE
1				
2				
3				
4				
5				
6				
7				
8				
9				
10				

Name of Joint Venture	
Names of Each Enterprise:	
(1) Name and Address of Enterprise:	
(2) Name and Address of Enterprise:	
(3) Name and Address of Enterprise:	
Has an original valid Tax Clearance Certificate been submitted for each enterprise:	Yes <input type="checkbox"/> No <input type="checkbox"/>
CIDB Registration Number(s), if applicable:	

Submit your Joint Venture Agreement together with this tender document. If no Joint Venture Agreement is submitted, the tender will be seen as non-responsive.

SIGNED ON BEHALF OF JOINT VENTURE _____



Mossel Bay
M U N I C I P A L I T Y
MOSSSEL BAY | HARTENBOS | GREAT BRAK RIVER | HERBERTSDALE

CONSTRUCTION HEALTH AND SAFETY SPECIFICATION

Issued in terms of -

Occupational Health and Safety Act, 85 of 1993
and
Construction Regulations, 2014

Contents

1. Definitions	71
2. Introduction to the Construction Health and Safety Specification	72
3. Limitation of liability	72
4. Purpose of the Construction Health and Safety Specification	72
5. Implementation of the Construction Health and Safety Specification	73
6. Scope	73
7. Compensation of Occupational Injuries and Diseases Act	73
8. Application for Construction Work Permit	74
9. Notification of Intention to Commence Construction Work	74
10. Risk Assessment for Construction Work	74
11. Principal Contractor's Health & Safety Plan	75
12. Health & Safety File	75
13. Cost of occupational health and safety	76
14. Induction	76
15. Health and Safety Training	76
16. General Inspection, Monitoring and Reporting	77
17. Incidents	77
18. Audits / Compliance Management and Monitoring	77
19. Fire Precautions and Fire Fighting Equipment	78
20. Personal Protective Equipment (PPE) and Clothing	78
21. Occupational Health and Safety Signage	78
22. Contractors	79
23. Fall Protection	79
24. Excavation Work	79
25. Explosives and Blasting	80
26. Demolition Work	80
27. Asbestos Work	81
28. Underground Services	81
29. Temporary Works	81
30. Ladders – GSR 13A	82
31. Piling / Drilling (Rig)	82
32. Construction Vehicles and Mobile Plant (including Hired Plant)	83
33. Electrical Installations and Machinery	83
34. Public Health and Safety	84

35. Night Work	85
36. Storage of flammable liquids	85
37. Hazardous Chemical Agent Management	86
38. Emergency and First Aid Management	86
39. Facilities for employees	87
40. COVID-19 Management	87
41. Penalties	87
Annexure 1 - CHSS Acknowledgement	88
Annexure 2 - CHSS Acknowledgement	89
Annexure 3 - Signed Mandatory Agreement S37(2)	90
Annexure 4 – Health and Safety File Index	92
Annexure 5 – Health and Safety Plan Index	93
Annexure 6 – List of Appointments	94
Annexure 7 – Baseline Risk Table	96
Annexure 8 – EMERGENCY NUMBERS	99

1. Definitions

For the purpose of this Construction Health and Safety Specification, the abbreviations or definitions given hereunder shall apply: (other as per legal definition will apply)

- “CR” Construction Regulations, 2014
- “CHSS” this document, the Construction Health & Safety Specification
- “OHSA” the Occupational Health & Safety Act of 1993
- “S” a Section in the Occupational Health & Safety Act of 1993
- “HIRA” – Hazard Identification and Risk Assessment
- “H&S” Health and Safety
- “Agent” occupational health and safety practitioner, appointed by the Municipality to act on its behalf, and who is appointed in writing.
- “Client” the Mossel Bay Municipality.
- “Regulations” the Regulations issued under the Occupational Health & Safety Act;
- “SSHSS” means Site Specific Health and Safety Specifications as per the CR
- “Site” the lands and other places, made available by the MBM for the purposes of the Contract, on, under, over, in, or through which the construction work is to be executed or carried out.
- “Principal Contractor” means an employer appointed by the client to perform construction work;
- “Contractor” means an employer who performs construction work.
- “MBM” means the Mossel Bay Municipality

2. Introduction to the Construction Health and Safety Specification

- This Construction Health & Safety Specification (CHSS) is published in terms of the Occupational Health & Safety Act of 1993 (OHSA), Construction Regulations 2014, Regulation 5.
- The CHSS does not replace the Construction Regulations, 2014, but is a supplementary specification as required in terms of the Regulations. Partial references to or quotes from the Regulations do not imply that the sections not referred to or quoted from are of lesser importance or are not applicable.
- The Principal Contractor is, at all times required to and will remain responsible to fully address all requirements and standards of the Occupational Health and Safety Act, Regulations, other relevant applicable regulations and or standards as may apply and the approved Health and Safety Plan, and then ensure the implementation thereof.
- The MBM is committed to ensuring that the highest standards of health and safety prevail at the Municipality.
- It shall be known within the MBM as the Construction Health & Safety Specification or CHSS.
- This CHSS must be included in all tender documents for construction work.
 - It may be supplemented on various projects by a Site-Specific Health & Safety Specification which deals with health & safety issues relevant to that specific project only; and
- The MBM may appoint an Agent who will (inter alia) be responsible for the approval of all Principal Contractors' H&S Plans based on the CHSS or the SSHSS, for the auditing of the Principal Contractors' implementation thereof, and for maintaining the document control associated with the CHSS / SSHSS.

3. Limitation of liability

- The MBM shall not be responsible for any acts or omissions of any Contractor which may directly or indirectly result from the application of the CHSS or any project specific version thereof.
- Contractors must always ensure that equipment, machinery, plant, and work practices are compliant to the legal requirements as these apply.
- Any other potential responsibility or alternative arrangement shall be dealt with in a Mandatory Agreement, as defined in Section 37(2) of the Act, or the contract.

4. Purpose of the Construction Health and Safety Specification

- The purpose of the CHSS is for the specification to be used as the standard on which a Contractors' H&S Plans must be based. The CHSS will be applicable on any construction project for the MBM.
- This CHSS shall be incorporated and considered when a SSHSS is developed.

5. Implementation of the Construction Health and Safety Specification

- This CHSS forms an integral part of the Contract, and Principal Contractors are required to make it an integral part of their contracts with their contractors and suppliers. It will be disseminated by the MBM to persons responsible for the design of infrastructure, projects and SCM, who will ensure that it is included in the Tender Document(s) issued to prospective Principal Contractors.
- The prospective Principal Contractors shall allow in their tenders for the cost of Health and Safety and complying with the requirements of the OHS Act and regulations, other legal requirements, this CHSS or additional SSHSS or other agreements.
- This CHSS shall be incorporated and considered when a SSHSS is developed.
- The Principal Contractor must provide the CHSS to their contractors.
- The Principal Contractor must **sign Annexure 1** of this CHSS.
- The (an) Contractor must **sign Annexure 2** of this CHSS. This would include a contractor of a principal contractor, and a contractor of a contractor. (a.k.a. sub-contractors)

6. Scope

- This CHSS covers the general requirements for addressing and mitigating Occupational Health and Safety related risks, problems, incidents, and injuries on projects constructed or executed for the MBM.
- The scope addresses legal compliance, hazard identification and risk assessment, promoting a health and safety culture amongst those working on MBM projects and those affected by the activities taking place in and around them.
- This CHSS serves as a guide and is not limited, i.e., the contractor must add as may be necessary to ensure safety and compliance based on their scope and associated risk and site / conditions.
- The CHSS contains clauses that are generally applicable to building and construction and imposes controls associated with activities that impact on human health and safety.
- The Principal Contractor is required to comply with the provisions of the OHSA, all applicable Regulations (in particular the CR), other relevant legislation and associated standards, this CHSS or additional SSHSS or additional agreements made.
- The MBM or its agent will monitor the Principal Contractor's legal compliance and the requirements of the CHSS / SSHSS their H&S Plan.

7. Compensation of Occupational Injuries and Diseases Act

- The Principal Contractor shall submit proof of registration as an employer, and proof of Good Standing with the COID Fund, prior to starting the work.
- A copy of the valid Letter of Good Standing with the COID Fund must be included in the H&S Plan and an updated copy kept in the H&S File.

8. Application for Construction Work Permit

- When required, this shall be managed as per CR 3 by an appointed Pr. CHSA.
- A copy of the permit must be placed in the H&S File and
- The permit number must be displayed on site.

9. Notification of Intention to Commence Construction Work

- After receipt of the Letter of Acceptance from the MBM the Principal Contractor shall notify the Provincial Director of the Department of Labour of a notifiable project, 7 days before work commences as per CR 4(1).
- The notification shall be similar in format to Annexure 2 of the Construction Regulations.
- The acknowledgement letter from DoEL and a copy of the notification to the Provincial Director must form part of the H&S File.
- Should the project go past the planned end-date the principal contractor must apply for extension of the notification and place such proof in the H&S File.

10. Risk Assessment for Construction Work

- The contractor shall ensure that a risk assessment as per CR 9 is in place
 - Conducted by a competent person.
 - in terms of an acceptable and documented methodology.
 - Site specific based on the scope of works, site, method statements and anticipated plant, machinery, and equipment.
 - Consider other applicable regulations as and where required.
- Risk assessments of all activities shall form an integral part of the Health and Safety plan and the foundation on which control measures and safe work procedures are based to effectively manage risk and ensure the health and safety of all persons.
- The HIRA, as performed by the appointed competent risk assessor is always kept up to date and on site and revised should there be a change in scope of work, an incident occurs or the request of the client or a DoEL inspector.
- As part of the risk management process ensure a competent person conduct DSTI's (daily safe task instructions) and consider the daily conditions, planned work and related hazards, and ensure the necessary controls are in place. This must be communicated to the team present on site.
- Our **Baseline Risk Table, Annexure 7**, is attached for your information.

11. Principal Contractor's Health & Safety Plan

- The Principal Contractor shall submit a site and scope specific health and safety plan, in accordance with the legal requirements, prior to work starting.
- This plan must be presented and approved by the MBM OHS Department or its agent prior to the site being handed over to the Principal Contractor.
- Besides the legal requirements, the health and safety plan **shall be structured as Per Annexure 5**.
 - a. The front page shall allow place for signature of the CEO or assistant (OHSA 16.1 / 16.2), Construction Manager (CR 8.1), Construction Supervisor (CR8.7)
 - b. Scope and site specific
 - c. Additional documents as may be required may be added at the end.

12. Health & Safety File

- The Principal Contractor shall provide and maintain on the construction site, a H&S File, containing all the documents as proscribed in the OHSA and Regulations and all documents referred to in the H&S plan and require the same of their contractors.
- The H&S File shall be available for inspection by the MBM, its Agent, or a Department of Employment and Labour Inspector.
- The H&S File shall be structured **as Per Annexure 4**.
 - a. Additional documents as may be required may be added at the end.

Consolidated H&S File: At Project Completion in terms of CR 7(1)(e)

- The Principal contractor shall compile a consolidated H&S File and hand this to The Client's Project Manager at the end of the construction work project that include a record of the drawings, designs, materials use and other similar information concerning the completed structure.
- The consolidated H&S File shall be in soft-copy format (USB)
The consolidated H&S File shall include:
 - 1) A list of all responsible persons appointed in statutory positions for the duration of the project.
 - 2) The comprehensive list of all the contractors on site accountable to the Principal Contractor, including a list of the agreements between the parties and the type of work being done.
 - 3) A copy of the approved H&S Documentation such as:
 - a. H&S Plan of the Principal Contractor.
 - b. Fall Protection Plan
 - c. Risk Register and Risk assessments
 - 4) Designer inspections/assessments and confirmation of conformance.
 - 5) A reference record of all drawings, designs and materials used
 - 6) A reference record of H&S statutory certificates required by the owner; this reference record shall indicate the designated person of the Principal Contractor who is responsible for the document and The Client-designated person to whom the document has been handed.

Reference records applicable to this project may include, but not limited to:

- a. Electrical certificate of compliance
 - b. Plumbing certificate
 - c. Structural certificate / design etc
- 7) A list / reference of all safety meetings held and related agenda.
 - 8) A list of any concerns raised, or urgent matters recorded in the site diary.
 - 9) Records of Site Inspections / Audits
 - 10) All documents relating to any reportable injury or disease during the construction work, as defined in Section 24 and 25, of the Occupational Health and Safety Act.
 - 11) Employee list and proof of inductions, SA ID document and Medical certificate of fitness.

13. Cost of occupational health and safety

- The budgeted cost of resources specifically aimed at Health and Safety compliance with this project must be documented in the Health and Safety Plan.
- Budgeting estimates must, amongst other, reflect:
 - Cost of training for statutorily defined Health and Safety appointees and competency's as may be required.
 - Cost of safety equipment / processes / procedures
 - Cost of Personal Protective Equipment
 - Cost for medical surveillance and medical certificates of fitness as per CR 7(8)

14. Induction

- The Principal Contractor must develop and conduct induction training pertaining to the hazards prevalent to their site / scope.
- The Principal Contractor shall ensure that all employees have gone through the induction training before commencing duties on site and that is relevant to the hazards present at the time of entry.
- The Principal Contractor shall place and keep an updated a copy of the attendance register in the H&S file.

15. Health and Safety Training

- See CR 1 Definitions: Competent Person
 - a. where required training shall be Unit Standard Accredited, and
 - b. that the competent persons be familiar with the OHSA and applicable regulations.
 - i. It is advised that all persons be made familiar with the act and applicable regulations so that they may better understand the requirements posed.
- Employees must be trained:
 - a. Relevant to their scope and identified hazards
 - b. On relevant specific method statements
 - c. On relevant specific safe work procedures / safe work instructions etc.

- Employees must receive communication of:
 - a. The H&S plan and other relevant plans e.g., Fall Protection Plan, traffic management plan etc.
 - b. The site risk assessment (identified hazards and associated controls)
 - c. Site induction
 - d. Site emergency procedures.
 - e. Other site / company procedures
 - f. Anything that may impact the Health and safety of the employees or others (including public) that may be affected by the actions of the contractor or because of the scope of work of the contract.
- Toolbox talks or similar are considered general awareness and is recommended for continual safety reminders.
- The Principal Contractor shall ensure that daily pre-task health and safety instructions are given to all employees.

16. General Inspection, Monitoring and Reporting

- The Principal Contractor must appoint the relevant persons as may be required to ensure that they shall carry out daily safety inspections on the site (or more frequent, where so required in the Regulations), and shall take steps to rectify any unsafe condition of which he is aware.
 - a. No “make-shift” / “sub-standard” repairs on equipment / tools / machinery or plant shall be allowed.
- The Construction Manager must ensure that continuous competent supervision and monitoring of work takes place.
- Report any incident to the MBM OHS Department or our agent.

17. Incidents

- All incidents must be reported to the MBM OHS Department or our appointed agent on the same day.
 - a. Telephone call and followed up with an email.
- All incidents must be recorded and investigated and reported on email, to the MBM OHS Department or our appointed agent.
- A competent person with sufficient knowledge, training and experience must investigate any serious incident, or where more than 7 days man-hours are lost, or if otherwise requested by MBM OHS Department or our appointed agent, or DoEL.
- A record of all incidents and investigations shall be kept in the H&S File.
- The Contractor shall ensure to maintain compliance and communication with Compensation Assurance (e.g., DoEL / FEM) regarding the necessary incident management.

18. Audits / Compliance Management and Monitoring

- Should the need arise (e.g., as in the case of the Principal contractor appointing another contractor) the Principal Contractor shall ensure that internal audits are conducted in terms of CR 7(1)(c)(vii)
- As required in terms of CR 5 duties we, MBM OHS Department or our appointment H&S Agent, shall conduct regular health & safety audits (at least once a month) to ensure compliance with the OHSA, its regulations and the approved H&S Plan.
- Records of audits must be kept, and non-conformance reported, investigated and corrective action must be taken to prevent re-occurrence.

19. Fire Precautions and Fire Fighting Equipment

- In compliance with CR 29 manage fire risk appropriately and therefore must be included in the risk assessment.
- Monitor and inspect a workplace prior to assess for fire / explosion risk and if required contact the MBM OHS department for assistance.
- Open fires are not allowed on site unless permission obtained from the MBM OHS Department / Fire Department and or our Agent.
- Smoking is prohibited unless in a designated area.
- The Principal Contractor shall provide and maintain suitable fire extinguishers, which shall be serviced regularly, in accordance with the manufacturer's recommendations.
 - a. And ensure that persons are available on site trained in the use and operation of a fire extinguishing equipment.
- Safety signage shall be prominently displayed in all areas where fire extinguishers are located.
- Combustible materials may not accumulate on site.
- Hot work done only after necessary pre-cautions have been taken.
 - a. At times a hot work permit may apply.
- An evacuation plan is available with clear egress routes to an assembly-point and a means of siren/fire alarm.
- The monthly fire extinguisher inspection register must form part of the H&S File.

20. Personal Protective Equipment (PPE) and Clothing

- The Principal Contractor shall ensure that every employee is issued with and wear SABS-approved PPE, based on associated risks, consisting of, at least: a hard Hat, steel-capped safety boots, a reflective vest and an overall.
- Clothing must show the company name of the contractor.
- Other specific PPE that may apply must be listed in the H&S plan according to the scope of works and risk assessment.
- The contractor must ensure that each person is familiar with the use and limits of each PPE item issued to them.
- Ensure to monitor the use of PPE by the employees.

21. Occupational Health and Safety Signage

- The Principal Contractor shall display and maintain quality safety signage.
- The signage shall include, but not be limited to:
 - a. A Site construction safety board / sign
 - i. warning on construction activities.
 - ii. Access restrictions.
 - iii. Emergency phone number(s)
 - iv. Minimum PPE to be worn.
 - v. Where falling objects may occur, relevant warning signs must be displayed.
 - b. Any other such signage as may be determined in the risk assessment

22. Contractors

- As per CR 7 - The Principal Contractor shall ensure that all contractors under his control comply with their own approved H&S Plans, based on the CHSS, the requirements of the OHSA and all other relevant legislation.
- Monthly audits of all Contractors must be conducted, and records filed in the H&S file, and made available to the MBM or our Agent.
- The principal contractor to ensure that the contractor is competent to perform the work and that they have the means for necessary OHS compliance.
- Ensure that competent supervision is present.
- The principal contractor to bring to the attention of the client / MBM OHS Department or our agent of any incident, non-compliance and or challenges that they might experience from a contractor.
- Provide the contractor with this specification and ensure they sign Acknowledgement of the Specification. Attachment 4.

23. Fall Protection

Should there be any fall risk:

- The Principal Contractor shall submit the name and the curriculum vitae of the competent person who has been appointed to prepare a fall protection plan, in terms of CR 10.
- The signed appointment letter and proof of competency must be included in the H&S File and submitted with the H&S Plan approval.
- The fall protection plan shall be as per the requirements set out in the regulations and be site and scope specific.

24. Excavation Work

Should there be any excavations:

- The Principal Contractor shall submit the name and the curriculum vitae of the competent person who has been appointed to supervise all excavation work, in terms of CR 13.

- Should there be any uncertainty regarding the stability of the soil, the opinion of a professional engineer or professional technologist be sought, the Principal Contractor shall submit the name and the curriculum vitae of the said professional.
- And include that where required / applicable a Geotech report be made available.
- Proof of competency and the appointment letters must form part of the H&S File.
- The records of the inspections contemplated in CR 13(2)(h) shall be maintained in the health and safety file.
- The Principal Contractor shall be responsible to and ensure that:
 - a. Provision is made in his tender for all shoring, dewatering or drainage of any excavation unless otherwise stipulated elsewhere in the Contract.
 - b. The excavations are inspected before the shift starts and that a record is kept.
 - c. There are no unguarded excavations, regardless of depth.
 - d. The safe working instruction has been communicated to the workers; and is enforced and always maintained by the Principal Contractor.
 - e. all excavated faces are maintained in a safe condition to protect any person and related works and to prevent injury or delays caused by slope failure.
 - f. No excavation shall be left open during the Contractor's holiday (December and January) and long weekends or other extended no-work periods.
 - g. All excavations which have not been finally backfilled and compacted at the commencement of the said holiday period shall be temporarily backfilled and compacted to a standard which shall:
 - i. Prevent damage occurring to the excavations or any other part of the Works.
 - ii. Prevent damage to or physical loss to property of any persons; and
 - iii. Eliminate the risk of injury to any person.

25. Explosives and Blasting

- The Principal Contractor shall ensure that the use of explosives and blasting (where required) be undertaken in accordance with the Explosive Regulations, 2002. by a competent specialist, with proven track record in the type of work to be performed.
- The letter of appointment and proof of competency must be included in the H&S file after prior submission to the MBM OHS Department or our agent for review.
- This includes explosive actuated fastening devices
 - a. Ensure compliance to CR21
- Prior notification and approval to the MBM OHS department and our agent is required should any form of explosive be used.

26. Demolition Work

Prior to any demolition work being carried out, the Principal Contractor shall submit the following as part of his H&S Plan:

- The name, letter of appointment and the curriculum vitae of the competent person who has been appointed to supervise all demolition work, in terms of CR 14.
- A safe working procedure and a detailed engineering survey of the structures to be demolished
- The Principal Contractor shall ensure that demolition work always complies with CR 14.

27. Asbestos Work

The Principal Contractor shall for any Asbestos Related work (during the dismantling and removal of asbestos containing material, including all asbestos fibre-cement products) ensure:

- Compliance with the Asbestos Abatement Regulations, 2020.
- Determine if it is type 1, 2 or 3 asbestos work and comply accordingly.
 - a. Not perform any asbestos related work of which they are not permitted / compliant.
- That all asbestos waste is disposed of only on sites specifically designated for the purpose of Asbestos in terms of the Environment Conservation Act, 1989, and the National Environmental Management: Waste Act, 2008; and
- A certificate(s) of disposal is provided to the client MBM OHS Department or our agent.
- Asbestos work might require an additional safety specification.

28. Underground Services

- The Principal Contractor shall prior to any form of digging / excavation / piling / drilling etc ensure that all reasonably possible means have been used to assess and determine if there are any underground electrical / other services.
- The Principal Contractor shall not allow or permit any of his personnel to manhandle any exposed electrical cable, unless directly authorised or instructed / requested to.
- All electrical cables shall be assumed to be “live”, and the Principal Contractor shall take adequate steps to ensure that members of the public are prevented for accessing any electrical cables.

29. Temporary Works

- Temporary Works includes all as per the Construction Regulations 1 definition. – compliance with each type shall be as per the applicable regulation or a combination thereof.
- Compliant to CR12 - The Principal Contractor shall submit the necessary appointment letters and proof of competency for the appointed / designated competent persons. *e.g.*
 - a. Temporary works Designer / Inspector*
 - b. Temporary works Supervisor*
 - c. Scaffolding Erector / Inspector*
 - d. Excavation Supervisor*
- A method statement shall be included in the H&S plan, addressing all aspects of safety management of erection, dismantling, and working on and around scaffolding.
 - a. The Principal Contractor shall ensure that all scaffolding complies with the legal requirements and safety standards.
- A method statement shall be included in the H&S plan, addressing all aspects of safety management during erection, use of and dismantling of false work, form work and support work.
- A method statement shall be included in the H&S plan, addressing all aspects of safety management during erection, use of and dismantling of any temporary structures / temporary works.

30. Ladders – GSR 13A

- The Principal Contractor must develop and communicate a safe work procedure to all their applicable workers.
- All ladders used to be fit for purpose, and
 - only be used for the purpose for which they are designed
- All ladders shall be maintained in a good and safe condition.
 - No “make-shift” / “sub-standard” repairs shall be allowed.
- Ladders shall be compliant to the statutory requirements / safety standard as may apply.
- Ladders shall be inspected visually before use and monthly recorded on a register kept in the H&S File.
- Ladders shall extend at least 90 cm above any level or opening accessed with the ladder.
- No vertical ladders shall be accessed by any person unless firmly attached at the bottom and top or held in place by a fixed installation or a buddy.
 - A drop-zone or similar be identified under and around the ladder work.

31. Piling / Drilling (Rig)

- The Principal Contractor shall ensure that where rig operations for piling or drilling is undertaken, it is done so by a competent specialist contractor or a Contractor with proven record in the type of work to be performed.
- Based on the Risk assessment, task and area specific method statements and safe work procedures shall be submitted as part of the H&S Plan and must be communicated to all person before start of activity.
- Recent (not older than 6 months) service records of equipment must be provided in the H&S File.

32. Construction Vehicles and Mobile Plant (including Hired Plant)

- The Principal Contractor shall ensure that all construction vehicles and mobile plant, whether owned or hired, complies with the applicable legislation and requirements of the OHS&A and applicable regulations.
- Use and operation there-of shall be done only within the legal limits and standards by a competent person.
- The Principal Contractor shall inspect and keep records of inspections of Construction Vehicles and Mobile Plant and equipment used on site.
- Operated by a competent operator - Only competent and authorised persons (appointed) with a valid competency and a valid medical certificate of fitness are to operate Construction Vehicles / Plant and Machinery, and as may be required under competent supervision.
- Appropriate safety equipment and clothing shall be provided for the operators and always maintained in good condition.

33. Electrical Installations and Machinery

- The principal contractor shall always ensure compliance to CR24.
- The Principal Contractor shall survey and identify the work area for any services. This may include underground, surface or overhead, and
 - a. shall appoint a competent person to (in the vicinity of or related to the work area)
 - b. identify and inspect all underground cables, overhead cables, and any electrical installations such as transformers or distribution boxes, to ensure that these are not a hazard to employees or to members of the public.
- The Principal Contractor shall develop and implement a method statement for the identification and safeguarding of all electrical services during the construction work.
- The Principal Contractor shall appoint a competent electrician who shall ensure zero potential of all electrical reticulations worked on and who shall ensure that dedicated power sources are safely installed for the use during the construction.
- The Competent electrician shall also be responsible to ensure safe and compliant electrical installations in the sections of scope of the project and issue a required CoC.
- The letters of appointment, proof of competency and inspection registers shall be included in the H&S File.

- All electrical cables shall be assumed “live” and, where applicable, the Principal Contractor shall take adequate steps to ensure that employees and members of the public are prevented from accessing any electrical cables and or installations.
- The Principal Contractor shall calculate and plan and include a method statement on the safe use of electrical reticulations of the MBM and avoid any overloading or shorting of the system.
- No live energy work shall be performed without prior acknowledgment from the MBM responsible person.
- Contractors must ensure that all energy is brought to zero potential, that residual energy is purged, that energy sources are switched off and locked out by all employees working in the danger zone and are tagged, prior to any work being performed on the energy source, reticulation or machinery.
- The contractor shall include a zero Potential, Lock Out and Tag Out method statement and safe work instruction(s) in the H&S File.
- No electrical machinery / tools shall be allowed to have any unsafe joined leads.
- The principal Contractor shall ensure that all electrical testing equipment to be used on site has a valid calibration and that the calibration sticker is affixed to the equipment, clearly indicating the calibration date and the next due date.
- Any unsafe condition shall immediately be reported to the MBM OHS Department, MBM responsible person or our agent and the contractor shall take immediate steps to prevent employees or members of the public from gaining access to the dangerous installation and the area surrounding it.
- The Principal Contractor shall appoint a competent person to inspect all portable electrical tools, including leads.
- The letter of appointment and template of the inspection register shall be included in the H&S File.
- The Principal Contractor shall include a method statement for the safe use of portable electrical tools, including the management of the hazards of extension leads and temporary electrical installations.
- A COC for all installations shall be provided; for temporary installations, the COC shall be placed in the H&S File on site.

34. Public Health and Safety

- The contractor is informed that the MBM at time may have certain scope of work / contract / tender or project that directly exposes public and or our staff.
- There are frequent visitors (as public) to our municipal premises or facilities (including use of infrastructure, services, facilities) and the contractor must ensure to assess and safeguard any person or property that may be exposed in any manner due to the scope of work given.
- Contractors are in their own entity as an employer obligated under the OHS Act Section 9 to ensure that persons are not exposed to hazards that may harm their health or safety.
 - a. MBM takes pride in ensuring to maintain a top-class construction site that always promotes good health and safety practices and aim to achieve this, thus requiring each contractor to do the same.

- Public are at times inquisitive and the contractors must therefore plan, apply and maintain:
 - a. Appropriate health and safety signage / lights / warning at all times.
 - b. Effective and physical access restriction to the construction site, in particular any drop / fall risk areas and moving plant / vehicles / machinery at all times;
 - c. Effective risk management – e.g., consider traffic, pedestrians, daily operations, weather etc.
 - d. Competent supervision
- When work needs to be conducted on public roads, the Principal Contractor must ensure effective traffic management in accordance with the South African Road Traffic Signs Manuel, in particularly Volume 2, Chapter 13.
- The Principal Contractor shall ensure that each person visiting the site (with the necessary reason / authority) shall be inducted to the site and such induction shall outline the hazards likely to arise from on-site activities and the precautions to be observed to avoid or minimise those risks.
- Even though environmental laws apply, in the context of public health & safety your actions / activities that may affect the environment must also be accounted for. E.g., Illegal disposal of waste / rubble shall not be tolerated.
- Consider noise pollution to those in the vicinity and manage accordingly.

35. Night Work

- Night work (after 18:00 and before 06:00 the next day) may not be performed, unless authorised by the MBM relevant project manager or our Agent.
- Ensure a suitable specific risk assessment is conducted for performing the task at night and that adequate controls are in place.
- The Principal Contractor shall ensure that adequate lighting is provided for all night work.
- It shall be discussed with the employees and determined if the employees are medically fit to perform night work.
 - a. And manage fatigue accordingly.
- All persons shall be issued with the required PPE for night work.
- Consider noise pollution to those in the vicinity and manage accordingly.
- Consider low light conditions
- Consider traffic management

36. Storage of flammable liquids

- Ensure compliance to GSR 4 and CR 25 and 29
- Flammable substances must be stored, used, and applied in such a manner that it does not create a fire or explosion hazard and that the workplace is properly ventilated.
- Ensure that as may be required every person involved are provided with suitable PPE.
- No smoking around any flammable substances.

- The H&S Plan shall include a method statement detailing the safe use, storage, decanting and spill controls for all flammable liquids used or stored on site.
- No excessive amounts of a flammable substance may be kept on site. I.e., no more than what is necessary at a particular time.
- Storage management must also comply with Environmental legislation.

37. Hazardous Chemical Agent Management

- Ensure compliance with Regulations for Hazardous Chemical Agents, 2021
- With respect to Hazardous Chemical Agents used, the contractor shall ensure that:
 - All SDS are included in the H&S file.
 - The safe use, storage, emergency procedures and safe disposal of hazardous agent are addressed in a method statement/s, included in the H&S Plan.
 - Proof of competency and signed letters of appointment of the person responsible for chemical handling, is included in the H&S file.
 - That first aiders are made aware of first aid procedures
- Any hazardous chemical agent intended to be applied on site during the project (i.e., after approval of the H&S Plan) shall be subject to an issue-based risk assessment and method statement, which must be presented to the MBM or our agent prior to the substance being introduced on site.
- No excessive amounts of an HCA be kept on site. I.e., no more than what is necessary at a particular time.

38. Emergency and First Aid Management

- The Principal Contractor shall ensure that adequately trained first aiders are on site at all times when construction employees are on site; this applies even if less than 10 employees are on site.
- First aiders shall be identifiable and shall have immediate access to a comprehensively stocked first aid box.
 - Such first aid box shall be stocked to include all first aid equipment as per the minimum requirements listed under General Safety Regulation 3, and any additional items identified in the risk assessment, for the area and scope of work.
- The Principal Contractor shall ensure that first aid employees are familiar with the rescue procedures from anticipated incidents and accidents.
 - E.g., may include technical rescues, fall rescues, confined spaces, water environments etc.
- The Principal Contractor shall assess the types and likelihood of incidents / emergency that may occur and ensure that adequately trained competent persons are available to assist with such emergencies.
 - E.g., may include technical rescues, fall rescues, confined spaces, water environments etc.

- Unless a unique or uncommon risk / scope and type of emergency is anticipated the contractor may not by default rely on the emergency services of the municipality.
 - Should the assistance of the MBM emergency Services be anticipated it must be requested, discussed, and agreed to in writing and the right remains reserved.
- The MBM OHS Department and MBM Emergency Services, must be notified of any anticipated high-risk scope of work and possible serious emergencies.
- All the above controls shall be documented in the H&S Plan.

39. Facilities for employees

- The Principal Contractor shall ensure compliance to CR 30 and the Facility Regulations as may apply and,
 - a. Provide facilities for safekeeping, e.g., lockers etc. for each employee;
 - b. Ensure that employees requiring to change on site can do so in privacy;
 - c. Ensure drinking water is available
 - d. Provide shade and
 - e. sheltered suitable eating area
 - f. Soap and a place to wash and dry hands
- The principal Contractor shall provide and maintain sufficient sanitary facilities on site in ratio as per CR 30(1)(b)
- And ensure that all is kept in a clean and hygienic condition.
- Ensure that good housekeeping is maintained, and the waste does not accumulate, and it is removed at regular intervals.

40. COVID-19 Management

- The Principal Contractor and its contractors must confirm to comply with the Code of practice Managing exposure to SARS-Cov-2 in the Workplace, and aid to assist us in best managing the SARS-COV-2 (COVID-19) spread by following requirements as may apply.
- At all times as best possible practices safe social distancing
- Educate and enforce mutual respect for the health of others. E.g., do not come to work if you are sick.
- Ensure all you workers are provided with and wear required PPE.
- Ensure to provide your employees with the required sanitisers.
- Manage COVID-19 according to the National Health Act (NHA), the Code of practice: Managing exposure to SARS-Cov-2 in the Workplace, and applicable regulations in conjunction with all other relevant legislation.
- Immediately notify the MBM OHS department should you have an employee that (has been to any of our “municipal areas”) show COVID-19 like symptoms or test positive for COVID-19.

41. Penalties

- Penalty Fee for OHS Non-Compliance will amount to R2000.00 per incident to the maximum of 10% of the total Contract Value including VAT.
- OHS Penalty Fee of R2000.00 will be applicable per incident, per site, per day, per area, per works, per non-compliance incident.
- Penalty Fee issued by the MBM OHS Department Officer, will be deducted from the Payment Certificate issued for work completed.

Annexure 1 - CHSS Acknowledgement

Acknowledgement by Principal Contractor

Construction Health and Safety Specification

issued in terms of the Occupational Health and Safety Act, 1993

Principle Contractor: _____

Project / Contract name: _____

Project / Contract number: _____

I, _____ (Name and Surname),

representing _____ (The Principal Contractor)

have satisfied myself with the content of this Construction Health and Safety Specification and shall ensure that we and any Contractor / supplier comply with it.

Principal Contractor
16(1) / 16(2)

Date

[Annexure 2 - CHSS Acknowledgement](#)

**Acknowledgement by
subcontractor**

Construction Health and Safety Specification

issued in terms of the Occupational Health and Safety Act, 1993

Contractor: _____

Project / Contract name: _____

Project / Contract number: _____

I, _____ (Name and Surname),
representing _____ (subcontractor name)

have satisfied myself with the content of this Construction Health and Safety Specification and shall ensure that we and any subcontractor / supplier comply with it.

Contractor
16(1) / 16(2)

Date

Annexure 3 - Signed Mandatory Agreement S37(2)

MANDATORY AGREEMENT

In terms of Section 37 (1) (2)
of the
Occupational Health and Safety Act (85 of 1993)

AGREEMENT BETWEEN:

Mossel Bay Municipality (MBM) & _____ MANDATORY
(Contractor)

WITH Compensation Fund Policy Number: _____

FOR the following Project / Contract / Tender: _____

1. Whenever an employee does or omits to do any act which it would be an offence in terms of this Act for the employer of such employee or a user to do or omit to do, then, unless it is proved that-
 - a. in doing or omitting to do that act the employee was acting without the connivance or permission of the employer or any such user.
 - b. it was not under any condition or in any circumstance within the scope of the authority of the employee to do or omit to do an act, whether lawful or unlawful, of the character of the act or omission charged; and
 - c. all reasonable steps were taken by the employer or any such user to prevent any act or omission of the kind in question,
2. The employer or any such user himself shall be presumed to have done or omitted to do that act and shall be liable to be convicted and sentenced in respect thereof; and the fact that he issued instructions forbidding any act or omission of the kind in question shall not, in itself, be accepted as sufficient proof that he took all reasonable steps to prevent the act or omission.
3. The provisions of subsection (1) shall "mutatis mutandis" apply in the case of a mandatory of any employer or user, except if the parties have agreed in writing to the arrangements and procedures between them to ensure compliance by the mandatory with the provisions of this Act.

Definition of Mandatory (OHS Act S1)

Includes an agent, a contractor or Contractor for work, but without derogating from his status in his own right as an employer or user.

AGREEMENT

In terms of the provisions of section 37(2) of the Occupational Health and Safety Act (85 of 1993)

I, _____ (name) representing / acting for and on behalf of

_____ (Mandatory) undertake to ensure that the requirements and provisions of the Act and all applicable regulations, the safety specification issued, and other agreements made are complied with.

Signature of Mandatory

Date

Signature of MBM

Date

NB: Signature of this Agreement means that the Mandatory has read and understands the "Requirements of Mandatories" addendum attached.

**REQUIREMENTS FOR MANDATORY / PRINCIPAL CONTRACTORS
ADDENDUM TO THE PRO FORMA "MANDATORY AGREEMENT"**

As we are fully committed to the Health and Safety of persons, and to as far as is reasonably practicable comply with the requirements of the Occupational Health and Safety Act (85 of 1993) (OHS Act) and any other applicable OHS (Occupational Health & Safety) legislation and standards, we require of our Mandatories / Principal Contractors to:

1. Sign a written "Agreement with Mandatory" as required by Sect 37(1)(2) of the Act before commencing any work on site.
2. Ensure that all your employees receive the necessary Induction Training and have proof thereof in your OHS File.

Note: You must ensure that all employees under your control are informed, instructed and trained by a competent person regarding any hazard and the related work procedures before any work commences.

3. Provide the MBM OHS Department with your H&S File – *Note: You are responsible for providing your own legal safety documents and registers to comply with the requirements.*
4. Ensure that Method Statements, Risk Assessments and Safe Work Procedures are done and available specific to the scope and your employees are informed of the content.
5. Provide the MBM OHS Department with written appointment of the person who is going to Supervise the Work. As per OHS 8(2)(i)
6. If required - Provide the MBM OHS Department with written designation of your nominated Health and Safety Representative as per Section 17(1).
7. If you employ more than five (5) persons, you are required to provide your own First Aid Box (GSR 3(2)).
8. If you employ more than ten (10) persons, you are required to provide your own qualified First Aider as per GSR 3(4)
9. When working with Hazardous Chemicals, comply with Regulations for Hazardous Chemical Agents, 2021. *Note: Asbestos and Lead dealt with separately.*
10. Construction work is excluded and shall be dealt with separately in compliance with Construction Regulations, 2014.
11. When using Lifting Machines and Lifting Tackle, comply with DMR 18 *Note: You may be required to appoint a Banksman to control Lifting/Slinging operations*
12. When installing / repairing air-conditioning, comply with DMR 16.
13. When accessing fall risk areas – ensure to compliance with GSR 6 and 13A. Scaffolding comply with the requirements of SANS-10085 “Access Scaffolding”
14. When doing Electrical work, comply with the requirements of EIR and EMR Construction *Note: Provide copy of registration as required*
15. When working over or near (in close proximity to) Water, comply with Construction Reg. 26
16. Ensure that good Housekeeping, Stacking and Storage principles are applied.
17. Ensure that appropriate measures are taken to avoid the risk of Fire/Explosion.
18. If you are going to work at heights a Fall Protection Plan must be submitted (roof work included) as per requirements of Construction Reg. 10
19. When using Explosive Powered Tools, comply with Construction Reg 21
20. When Welding, Flame Cutting/Soldering, comply with GSR 9
21. When working in Confined Spaces, comply with GSR 5
22. You are required to comply with General Safety Regulations 2 and provide your employees with: personal protective equipment which will allow them to carry out their work in a safe manner.
23. Reporting, Recording and Investigations of Incidents or Occupational Diseases shall be done as per General Admin. Regulation 8 / 9 (Also see Sect 24 of the Act) – none the less always be reported to the MBM OHS Department.
24. You are required to provide proof of registration with the Compensation Commissioner/ Federated Employer(s) Mutual when signing this agreement. If you are not registered, we may deduct the necessary amounts from your progress payments and pay it over to the Commissioner to ensure that you are insured. See Section 80 and 89 of the COID Act.
25. Manage SARS-COV-2 (COVID-19) as per the latest current legislation and comply with the requirements posed by the MBM.

Annexure 4 – Health and Safety File Index

- Cover Page (Contract Award Letter / Appointment Letter) Project details – Name Company details etc)
 - Index of the H&S File (*This Annexure 4*)
1. Notification of Construction Work (annexure2) and proof of delivery or if required Construction work Permit
 2. Letter of good standing COIDA
 3. Occupational Health and Safety Policy
 4. Relevant drawings / designs
 5. Risk Management
 - a. Issue Based Risk Assessments, & DSTI Template
 - b. Risk monitoring and review records
 6. H&S Plan (*Annexure 5*) - Including Plan Approval Letter from MBM.
 7. Fall Protection Plan

8. Method Statements / SWI
9. Permission / agreement letters (for when special permission required from client) e.g., night work.
10. HR Management
 - a. Organogram
 - b. List of Appointments (*Annexure 6*) & signed letters of appointments
 - c. Evidence of competency (registrations, qualifications, and other proof of competency)
 - d. Employee lists
 - e. Medical Certificates of Fitness
11. Contractor Management
 - a. List of Contractors
 - b. Their appointment letters
 - c. Their H&S File / Plan Approvals
12. Training Management
 - a. Competency Training Matrix
 - b. Training records / Certificates (other than for specific appointments)
 - c. Risk Assessment, H&S Plan, Fall Protection etc. communication
 - d. Training registers of Method statements, SWP's / SWI's etc
13. CH&S Induction (Staff and Visitors)
 - a. Induction Content
 - b. Records of inductions (Staff & Visitors)
14. Emergency, Accident, and Incident Management Plan
 - a. Emergency Plan / Incident Management
 - b. Incident Register
 - c. First aid treatment (this can be in the first aid kit)
 - d. Investigation reports & COIDA
15. H&S Inspection & Maintenance Registers
16. PPE Management
 - a. Issue Register
 - b. Training records
 - c. Inspection records
17. Audits & Including Corrective / Preventive Action plans for audits
 - a. Internal Audits
 - b. Contractor Audits
 - c. Client Audits
 - d. DoEL Audits
18. Signed Section 37(2) agreements (*Annexure 3*)
 - a. Agreement between The Client and the Principal Contractor
 - b. Agreement between the Principal Contractor and each Contractor
19. HCA Management
 - a. List of Hazardous Chemicals / Agent or Products that contain HCA's and their SDS's
 - b. Communication records
 - c. First aider familiarisations records
20. Waste Management
 - a. Plan / Process / Procedure
 - b. Disposal Records
21. This CHSS & Signed Acknowledgement of CHSS (*Annexure 1 or Annexure 2* for contractors)
22. Toolbox talks
23. Records of site safety meetings
24. Other

Annexure 5 – Health and Safety Plan Index

- Cover Page
 - Index of the H&S Plan (*This Annexure 5*)
- A. Scope of work & activities, equipment, machinery, plant, hazardous articles, and selected contractors to be used in the project
 - B. Project-specific baseline hazard identification and risk assessment & risk register
 - C. Health and Safety Resources and Budget
 - D. Competency of Principal Contractor
 - 1) List of 5 Previous similar projects / construction activities
 - 2) OHS competency
 - E. Organisational chart including list of employees

- F. Safety officer: duties, responsibility, authority, document control, communication
- G. Principal Contractor H&S management processes:
 - 1) Risk Management: such as the issue-based risk-, risk review- and risk monitoring
 - 2) H&S Induction, training, and H&S competency management (including OHS Induction and applicable safe work instruction templates)
 - 3) General record keeping management
 - 4) Contractor and Sub-contractor management
 - 5) Site communication management
 - 6) Fatigue management
 - 7) First aid, accident & incident, and emergency management
 - 8) Fire prevention and equipment & hot work management
 - 9) Safety signage management
 - 10) Access & on-site traffic and public H&S management
 - 11) Fall Risk Work Management
 - 12) Temporary work management
 - 13) Scaffolding management
 - 14) Ladder safety
 - 15) Demolition management
 - 16) Electrical management
 - 17) Delivery, offloading, stacking, storage, and housekeeping management
 - 18) Hazardous chemical substances management
 - 19) Construction plant and machinery management
 - 20) Hired plant and machinery management
 - 21) Lifting and rigging management
 - 22) Employee facilities management
 - 23) PPE management
 - 24) Safety Inspections and Inspection Register management
 - 25) Internal Audit management
 - 26) Waste management
 - 27) Other

Annexure 6 – List of Appointments

CONSTRUCTION APPOINTMENTS (Not limited)

#	Designation	Legal reference	Name and proof of competence
1.	Assigned Responsibility Designation	OHSA S16(2)	
2.	Construction Manager	CR 8(1)	
3.	Construction Supervisor	CR 8(7)	
4.	Construction Supervisor Assistant	CR 8(8)	
5.	Traffic controller	S 8(2)(i)	
6.	Contractor of principal contractor	CR 7(1)(c)(v)	
7.	Sub- Contractor of contractor of principal contractor	CR 7(1)(c)(v)	
8.	Emergency / Fire Co-Ordinator	OHSA S8	
9.	Fire Extinguisher Inspector	CR 29(h)– PER 19	
10.	First Aider	GSR 3	
11.	Safety Officer - CHSO	CR 8(5)	
12.	Incident Investigator	GAR 9	
13.	Risk Assessor	CR 9(1)	
14.	Risk Assessor (on-site)	CR 9(1)	
15.	Demolition Supervisor	CR 14	
16.	Excavation Supervisor	CR 13	
17.	Fall Protection Plan Developer	CR 10(1)(a)	
18.	Temporary works designer	CR 12(1)	
19.	Temporary works supervisor	CR 12(2)	
20.	Construction Vehicle & Mobile Plant Inspector	CR 23(1)(k)	
21.	Construction Vehicle & Mobile Plant Operators	CR 23(1)(d)	
22.	Registered electrician	EIR 5(4,5)	
23.	Electrical contractor	EIR 6	
24.	Electrical Installation Controller	CR 24(c)	
25.	Electrical Installation Inspector	CR 24(d)	
26.	Ladder Inspector	GSR 13A	
27.	Lifting Machine Operator	DMR 18	
28.	Portable Electrical Equipment Inspector	EMR 9	
29.	Scaffold designer	CR 12(1)	
30.	Scaffold Erector / Inspector	SANS 10085	
31.	Scaffolding Supervisor	CR 16(1)	
32.	Stacking & Storage Supervisor, including chemicals	CR 28	
33.	Responsible for housekeeping	CR 27	
34.	Person Responsible for HCS	HCS	

Annexure 7 – Baseline Risk Table

BASELINE RISK ASSESSMENT

Scope of the works (as indicated on the drawings or by alternative instruction) and scope of work issued

Hazardous events

- (1) The Client identifies the following hazardous events specific for this construction project:
 - a) The Client employees, visitors, public or other services may possibly access the site and get injured.
 - b) Electrical works - may pose a risk of fire, electrocution and electrical shorting;
 - c) Demolition work may cause a fall and collapse risk
 - d) Brick / concrete works may pose dust-, fall-, drop-, and collapse risks.
 - e) Height work with a risk of falling.
 - f) Traffic Risk -transporting, delivery etc of material, persons, and equipment inclusive but not limited
 - g) Damage to client /public property or infrastructure
- (2) General construction activities from which hazards and risks emanate, which are universal for this type of construction work include:
 - a) Transport of persons, equipment, and articles to and from the site with associated transport and road-risks
 - b) Off-loading and loading of equipment and articles with associated rigging, lifting and mechanical risks (crushing of persons, crushing of limbs, hand injuries)
 - c) Use of small power (electrical and combustion) plant on site with associated health risks (diesel-, dust- inhalation, noise, whole body vibration, prolonged sitting work) and safety risks (mechanical risk of cutting, crushing, running out of control and operator fitness, training & competency)
 - d) Material handling with the ergonomic hazards of repeated bending, lifting, and carrying heavy objects.
 - e) Crush hazards during lifting, carrying, and placing of heavy objects
 - f) Manual handling with the ergonomic hazards of using hand tools, power tools (grinder, concrete cutter, jackhammer, drill etc), heavy objects lifting or torquing of the body
 - g) Hazards associated with a demolition-dust, cement-dust, and concrete dust exposure during, respectively, demolition, concrete- and dagga-mixing, concrete cutting or grinding, painting and glues
 - h) Lacerations from sharp objects such as metal objects
 - i) Work at a fall risk position
 - j) Exposure to HCS, and possibly HBA – posing some health and safety risks
- (3) Table C (following page) lists the tasks, machinery or installation exposure which may cause the health and safety hazards and associated risks during this project.





TABLE C

Hazard	Task-machinery-installation exposure	Safety risk	Health risk
Noise	Grinders / breakers	Acoustic trauma, Communication error leading to accidents	Noise induced hearing loss
Hand Arm Vibration	Grinders, jackhammer-operator		Work related upper limb disorders
Electricity	Existing or new services Electrical reticulation & portable machinery Unknown services	Electrocution Fire	
Construction dusts (demolition, cement, sanding, paint)	Dust from works	Bronchospasm – skin–eye irritation	Asthma – dermatitis - conjunctivitis
Paints, glues, thinners	Painting		Irritation Neurological effects
Lifting/bending	All manual work	Acute muscular strain	Chronic muscular strain
Repetitive actions	Most laborer’s manual work		Chronic muscular synovial –skeletal damage
Prolonged standing	Most laborer’s manual work		Venous stasis, oedema, backache
Impact strain	Work with hammer, pick, spade		Headaches, muscular pain neck and shoulders
Working at heights	Access and egress at heights and work at fall risk position	Falls – serious injury / death	Muscular strain
Fitness for duty	Intoxication by employees- drugs/alcohol/medication	Accidents leading to injury	
Employee wellness	Personal – social –financial professional-health	Accident	Negative knock-on affecting work culture
Fatigue	Monotonous work, overtime, work rostering, personal issues	Lacerations, fractures, caught in machine or traffic	No-care mindset
Dangerous work	Fall Risk Handling sharp objects Excavations and work in excavations Scaffold erection Work with electrical installation Installation / commissioning of new installation	Falling Lacerations, fractures, crush injuries and death Falling objects injuries Electrical shock Pinch, crush and drop	
Dangerous equipment	Small plant, Mobile construction plant, Compactors	All sorts of accident-risks	
Dangerous Actions	Unauthorised work at heights or in drop zones Unauthorised demolitions, slips, trips, falls Live electrical connections	All sorts of accident-risks	All sorts of disease- risks
Lifting and rigging	Unsafe lifting and Using unsafe equipment	Various serious and possible fatal results.	

HEALTH AND SAFETY BASELINE RISK ASSESSMENT

Construction work	Hazardous Event	Health & Safety Risk
Access and transport on and to site	Transportation, traffic control	Motor vehicle accident and fatalities
Site establishment	Rigging – off loading- placement of containers and machinery	Falling objects - Sliding objects Cuts and lacerations – crush injuries
Off-loading equipment, machinery, materials	Manual rigging and possible crane operations- rigging- movement of equipment	Falling and moving objects or machinery Ergonomic strain, crush, death
Storage & stacking	Moving storage or stacks (bricks, sheets etc.)- picking off stacks	Falling objects or machinery- crush injuries
Chemicals and fuels	off-loading into bulk storage, decanting – refueling - spills	Fire, explosion, health, and safety of persons – chemical burns etc.
Members of the public in construction area	Public close to works in progress exposed to hazards	Injuries- death
Unidentified services	Electrocution, water leaks	Shock, burns, death, flooding, death
Electrical services and installation	Electrocution	Shock, burns, death, electrical explosion, death
Brick -and concrete works	Handling cement, concrete, heavy objects Falling structure- especially where retarding mortar is used	Skin, eye chemical insult, ergonomic strain
General construction work	Hand tools- small portable electrical tools- manual handling- sharp articles – electricity	Hand-, eye injuries, crush injuries, noise exposure, dust exposure – ergonomic strain –electrical shock - fire
Ladder –scaffold work	Collapsing –fall -drop	Severe injury- death
Chemical substances	Cement-dust- glues-paints- thinners, other HCS	HCS-specific illness
Lifting, rigging operations	Lifting articles	Falling articles- severe injury, death
Manual lifting and repeated movement	Ergonomic stress	Back and other muscular injury or disease
Manual work	Use of hands – strain on muscles and back	Lacerations, crush injury, back injury, muscle injury
Installation work at heights	Fall risk – drop risk, Ergonomic strain	Serious injury, death, musculoskeletal strain
Temporary works	Fall risk – drop risk Collapsing structure	Serious injury, death, musculoskeletal strain
Installation of fittings	Manual work- small power tool work- awkward positions – sharp objects	Lacerations – eye injury - musculoskeletal strain
Carpentry – shop fitting – flooring	Manual work- small power tool work- awkward positions – sharp objects	Lacerations – eye injury - musculoskeletal strain
Demolition	Structural collapse- impact tools- unidentified services-	Crush-, eye-, skin-, hand and shoulder injuries- severe to death

Annexure 8 – EMERGENCY NUMBERS

EMERGENCY NUMBERS		
FIRE, RESCUE & DISASTER MANAGEMENT SERVICES		MBM <u>044 691 3722</u> 044 606 5107 / 5121
AMBULANCE		By Grace EMS 063 675 1936
		ER24 084 124
HOSPITAL		Life Bay View 044 691 3718 044 601 1956
		Provincial 044 691 2011
		Great Brak Clinic 044 620 2288
POLICE (SAPS)		Mossel Bay 044 606 2805
		Da Gamaskop 044 606 2200/2201
		Kwanonqaba 044 606 5600
		Great Brak 044 620 8300
TRAFFIC DEPT (GENERAL)		MBM 044 606 5201
ELECTRICAL		MBM 044 606 5114
WATER		MBM 044 606 5278
GENERAL		MBM 044 606 5000
MBM OHS		L Mzekandaba 044 606 6261

COPYRIGHT NOTICE

This drawing is the confidential property of BNM ARCHITECTS and may not be disclosed to a third party, copied or reproduced in whole or in part without the permission of BNM ARCHITECTS

The contractor is to keep a full set of drawings on site. contractor is responsible for the correct setting out of the building on site with particular reference to boundaries and building lines, contractor to verify all levels and dimensions on site and check same against architects and engineers drawings before commencing work. Figured dimensions to be used in preference to scaled dimensions, large scale details to be used where available, errors, discrepancies or omissions are to be reported to the architect immediately for clarification before work is undertaken.

These drawings are to be read in conjunction with structural engineer's, civil engineer's, mechanical engineer's or plumbing consultant's drawings where specified.

All work and material used to comply with SABS standards and NATIONAL BUILDING REGULATIONS ACT 103 of 1977 and amendments thereto as well as the by-laws of the relevant local authority.

ALL WORK TO BE IN STRICT COMPLIANCE WITH SANS 10400
All new construction HEALTH AND SAFETY Regulations to be strictly complied with. A comprehensive Health & Safety Plan to be submitted to the Principal Agent/ Project Manager for review and monitoring.

All fire installations and equipment to be according to SANS 10400 regulations.

For all drainage, stormwater and site works refer to engineers drawings details and specifications

For service connections refer to engineers drawings

date	rev	description

notes
The contractor is to verify all dimensions on site before commencing any part of the work. Errors, discrepancies or omissions are to be reported for clarification.

BNM architects accept no responsibility for any construction proceeding prior to the granting of approval from the relevant local authority and / or interested party/ies.

BNM ARCHITECTS PROJECT MANAGERS
 19 milner street, uitenhage
 po box 686, uitenhage 6230

(Pty) Ltd 2020/775519/07
 tel: +27 41 992 5433
 fax: +27 41 922 7124
 email: bnmud@ud.bnm.co.za
 web: www.bnm.co.za

client

Mossel Bay MUNICIPALITY

drawing name
SITE PLAN

project details
PROPOSED NEW OFFICE BUILDING FOR SPCA K9 UNIT ON LEASE AREA NO 3 OVER THE REMAINDER OF ERF 2001 MOSSEL BAY

drawing number
3260-B-01

revision
-

drawn	checked	scale	date
Marais	J.J. LOMBARD SACAP 6334 PROF. ARCH.	AS SHOWN	2026-04-10

PROFESSIONAL ARCHITECT
JACOBUS JOHANNES LOMBARD

0826 AM (Africa/Johannesburg) on 21 May 2025

client signature **architects signature**

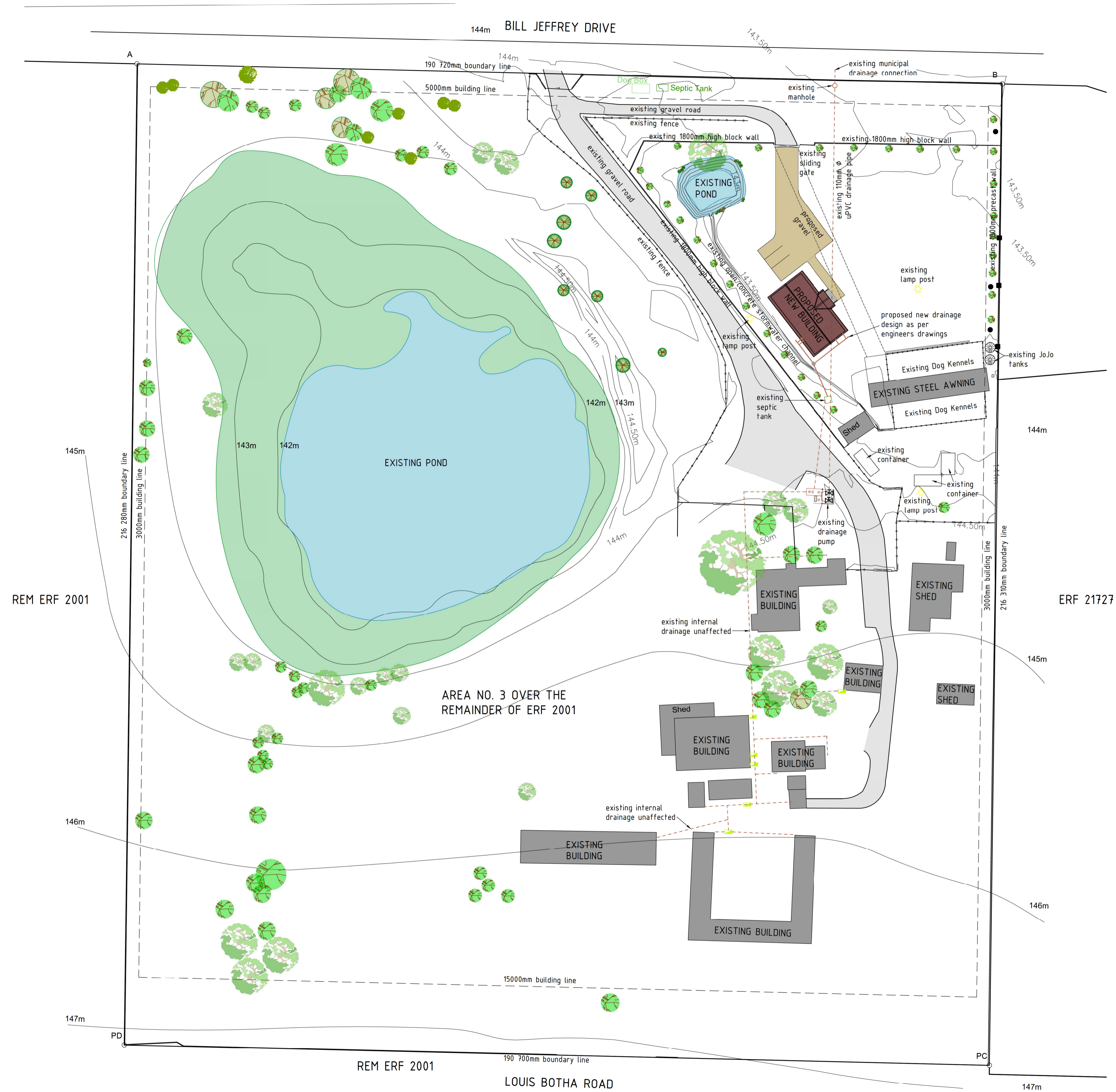

SITE PLAN
SCALE 1 : 500

NOT FOR CONSTRUCTION, INFORMATION PURPOSES ONLY.

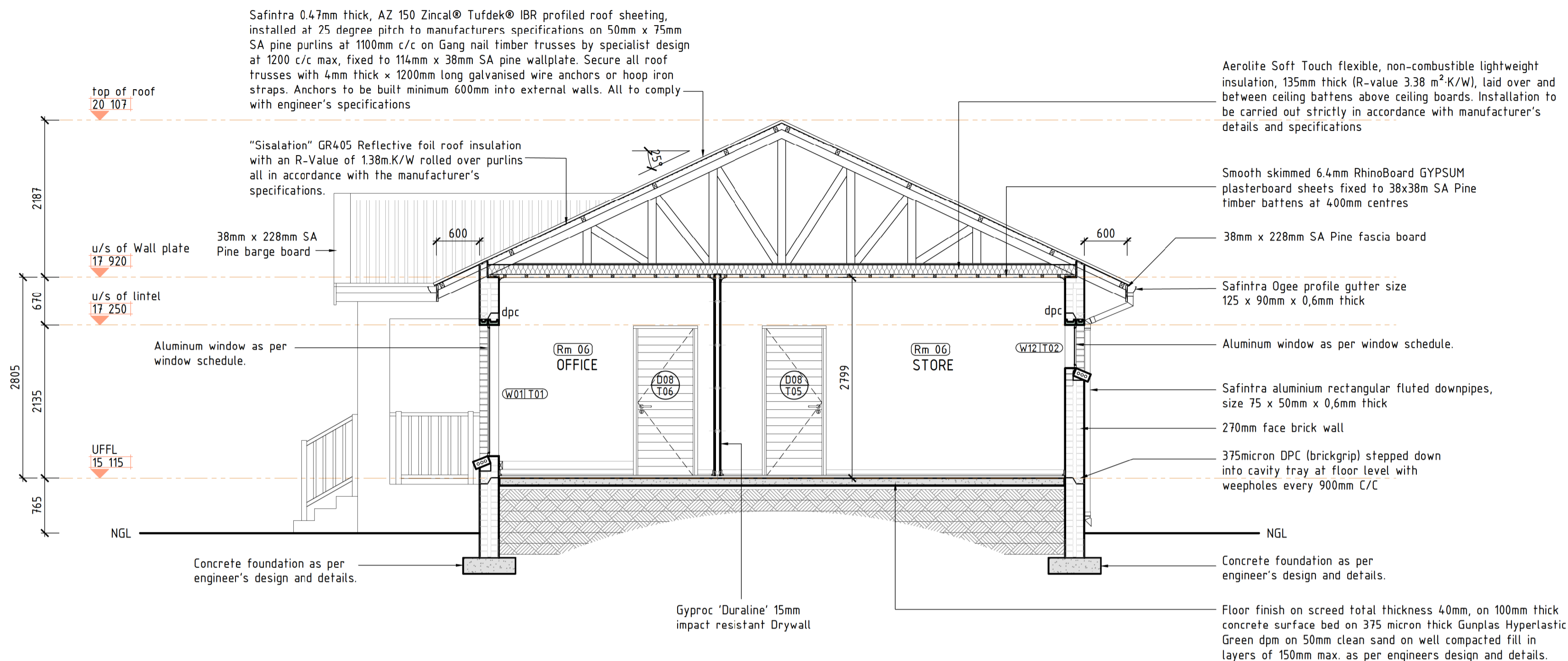

SECTION AA
SCALE 1 : 50

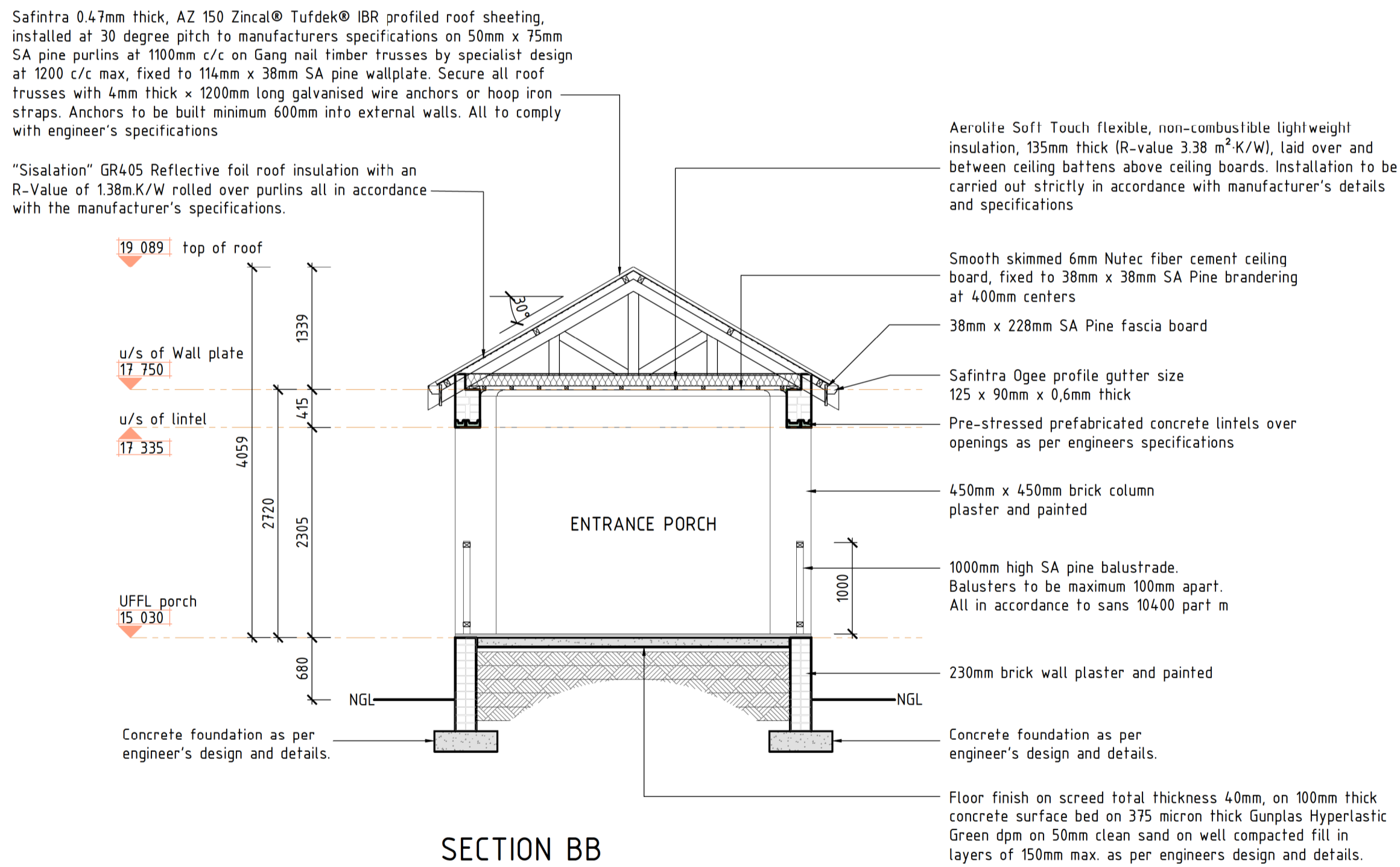

SECTION BB
SCALE 1 : 50

ROOF CONSTRUCTION:

- All roofs to be designed and signed off by engineer.
- Safintra 0.47mm thick, AZ 150 Zincol® Tufdek® IBR profiled roof sheeting, installed at 30 and 25 degree pitches (as indicated on roof plan) to manufacturers specifications on 50mm x 75mm SA pine purlins at 1100mm c/c on Gang nail timber trusses by specialist design, at 1200 c/c max, fixed to 114mm x 38mm SA pine wallplate. Secure all roof trusses with 4mm thick x 1200mm long galvanised wire anchors or hoop iron straps. Anchors to be built minimum 600mm into external walls. All to comply with engineer's specifications
- With "Sisalation" GR405 Reflective foil roof insulation with an R-Value of 1.38mK/W rolled over purlins all in accordance with the manufacturer's specifications.
- Install ridge flashings and barge boards to all areas required as per manufacturers specs.
- Install valley gutter as per manufacturers specifications.

RAINWATER GOODS:

- Safintra Ogee profile pre-coated Aluminium-Zinc seamless gutter, size 125 x 90 x 0,6mm thick in colour Light Grey including matching rivet-fixed mitres and end caps internally sealed using Silicon Mastic, hung by nail fixed internal aluminium hangers at 800mm centres, with Safintra aluminium rectangular fluted downpipes, size 75 x 50 x 0,6mm thick in colour Light Grey fixed to walls with pre-painted downpipe cleats using nail-in anchor fixings.

WALL FINISH:
EXTERNAL WALLS

Face brick
"Corobrik" Kathu Red Travertine Face Brick.

Paintwork:
As indicated on elevations - Prepare and apply one coat Plascon Merit plaster primer (thinned 20% with mineral turpentine) and apply two full coats Plascon MicaTex colour as per architect.

INTERNAL WALLS

Paintwork:
Prepare and apply one coat Plascon plaster acrylic filler coat, fill with interior Polyfilla, sand and touch up filler coat and apply two full coats Plascon Wall and All - colour as per architect.

WINDOWS & DOORS - GLAZING:

- TO COMPLY WITH SANS 10400 PART 'N'
- All sections and powdercoating for windows and doors as per AAAMSA specifications for coastal conditions.
- Where ordinary glass is installed the nominal thickness will be 6mm.
- Glazed areas exceeding 1m² to be safety glass.
- Glazing within 500mm above floor to be safety glazed.
- All glass used in doors to be safety glazed.

CEILINGS:

Ceilings
• Smooth skimmed 6.4mm RhinoBoard GYPSUM plasterboard sheets fixed to 38x38mm SA Pine timber battens at 400mm centres, joints covered with 63mm wide wire mesh strips, the whole ceiling finished with CreteStone skimmed level and smooth and painted, all as per manufacturer specifications.

Paintwork: Prepare and apply one coat plaster acrylic filler coat, fill with interior Polyfilla, sand and touch up filler coat and apply two coats Acrylic PVA. Colour : as per Architect

Entrance Porch

- 9mm Nutec fibre cement ceiling boards (or approved equivalent) fixed to 38x38mm timber bracing at maximum 400mm centres, fixed with 25mm corrosion-resistant bands at maximum 150mm centres, joints taped with RhinoTape and flush plastered with 6mm RhinoLite / CreteStone to a smooth finish. Prepare and apply one (1) coat Universal Undercoat, sand and touch up undercoat and apply two (2) coats Velvagio Satin Enamel paint. Colour: white.

CEILINGS - INSULATION:

- Aerolite
• Provide and install Aerolite Soft Touch flexible, non-combustible lightweight insulation, 135mm thick (R-value 3.38 m²K/W), laid over and between ceiling battens above ceiling boards. Installation to be carried out strictly in accordance with manufacturer's details and specifications

CORNICES:

Internal Ceiling
"Summit" XPS008 poly-styrene cornices - 65x65mm Coved - installed and finished as per manufacturers specifications

Entrance Porch

75mm Nutec Nucornice installed and finished as per manufacturers specifications.

SKIRTING:

- 76mm x 19mm selected wrot Meranti skirting, slightly rounded on top leading edge, screwed to walls at 400mm centres. The skirting is to have splayed header joints and mitred angles, complete with 19mm quarter round. Skirting's to be stop, properly sand down, cleaned and finish with 3 coats clear Eggshell Polyurethane Varnish. All to manufacturers specifications and recommendation

- Note: All linear jointing to skirting to be vertically right angled butt jointed. All wall painting and floor finish to be complete prior to skirting fixing. Floor finish to be masked during final coat of skirting varnish.

GENERAL:

- Contractor shall be deemed to have acquainted themselves with site conditions and make allowances in their tenders for all site development work.
- Any deviation from the plans has to be reported to the ARCHITECT before such deviation is applied, and a new altered plan has to be acquired before any deviation may be made.
- All work to be in accordance with the national building regulations (NHBR) and the standards act SANS 10400, SANS XA & SANS 204.
- All work to be in accordance to Local Authorities regulations and by-laws.
- Figured dimensions to be taken in preference to scaled dimensions.
- All dimensions and levels to be verified on site. Any discrepancies to be reported and rectified before any building work commences or continues.
- Stepped DPC to be built in as per SANS 10400 & NHBR regulations above all openings and between all internal floors & external walls
- DPC to be built in to all horizontal openings as per SANS 10400 & NHBR regulations.
- All foundations to be min 400mm below virgin soil.
- All precast lintels to be laid in accordance with engineers specifications with min 230mm overlap per side.
- All doors leading to the outside to have a threshold / weather step.

HEALTH & SAFETY

- The Contractor is to ensure that, in terms of the Occupational Health and Safety Act, Act 85 of 1993, with specific reference to the Construction Regulations, they do comply with the minimum requirements.

SETTING OUT OF BUILDING / REMOVAL OF TREES:

- The building to be laid out and erected in the position as indicated on the site layout plan.
- Where large tree, tree stumps and stones are to be removed in the area, the hole must be filled with suitable material and well compacted in layers of max 150mm before being built or paved upon.

GENERAL FIRE SAFETY NOTES:

- All fire installations to be as per SANS regulation
- Fire Hose Reels to be installed as indicated on the drawing.
- Hose reels to comply with SANS 543 with 30m long 20mm diameter light rubber hose with fixed base and fitted with couplings, connection, and branch pipe. Water supply to be sufficient ensuring flow rates and pressures as follows: Hosereels - 0,5 litre /second @ 300kPa.
- Water supply pipe to Hosereels to be not less than 32 mm (Copper or Galvanized Pipe) All fire hose reels must be fitted with a service label.
- The Hose reel installation to done as per engineers design and specifications.
- Fire Extinguishers to be installed as indicated on drawing.
- Portable fire extinguisher to comply with the requirements contained in SANS 810, SANS 889 or SABS 1151, as the case may be, and shall be installed, maintained and serviced in accordance with SANS 0105.
- All fire extinguishers must be fitted with a service label in compliance with SANS 1475.
- All fire extinguishers to be installed on a wooden backing board unless specified otherwise.
- All fire-fighting equipment, fire escape routes to be indicated by photo-luminescent symbolic safety signs that comply with SANS 1186-5.

GENERAL DRAINAGE NOTES:

- All sewer lines to be min 110mm diameter pvc at min fall of 1:60 and max. fall of 1:10 laid in accordance with SANS 10400 with min cover of 450mm.
- Install RE's & IE's at all bends and junctions with marked covers at ground level.
- No length of sewer pipe longer than 20m to be installed without a RE.
- Min 1 gully to be installed per sewer line lower than the first fitting on the line.
- Closed sewer system to enter at 45 degree junction.
- All pipes seals and materials used to comply with SANS standards
- All drainage must be tested that it is leak free
- All sewer lines to be laid in accordance with SANS 10400 part P sections 4.22
- All sewer installations to be carried out by a registered plumber. A certificate of compliance in accordance with SANS regulations to be issued to the Architect

GENERAL ELECTRICITY:

- All electrical work to be done by a certified electrician.
- All electrical cables and wires in walls, floors, concrete soffits and ceilings to run in SABS approved conduits and / or trunking and / or cable trays.
- A certificate of compliance to be issued to the architect.

FOUNDATIONS:

- TO COMPLY WITH SANS 10400 PART 'H'
- EXCAVATIONS TO COMPLY WITH SANS 10400 PART 'G'
- All foundation to Engineer's design and Specifications.
- All foundation trenches to be inspected by the engineer and building inspector, and approved before foundations are cast

FLOOR CONSTRUCTION:

- TO COMPLY WITH SANS 10400 PART 'J'
- Floor finish as per tiling layout, on screed total thickness 40mm screed, on 100mm thick RC concrete surface bed, on 375 micron thick Gynplas Hyperlastic Green dpm on 50mm clean sandbed on well compacted fill in layers of 150mm max. as per engineers design and details.

WALL CONSTRUCTION:

- TO COMPLY WITH SANS 10400 PART 'K'
- General
• Brickwork sample panels to be built on site for approval before commencing with the work.
- Moisture content of walls to be measured before the application of any paint finishes, and not to exceed 5%.
- The surfaces of all plastered walls and concrete as well as all other surfaces to be prepared in accordance with the specifications and requirements as per the paint manufacturers.

Cavity walls

- Cavities in foundation walls to be filled with grade 10 concrete as per engineer detail and specifications.
- 375micron DPC to all walls.
- All cavity walls to have 375micron DPC (brickgrip) stepped down into cavity tray at floor level with weepholes every 900mm C/C and above precast concrete lintels. All opening to have DPC all around as per NHBR
- 375 micron 300mm wide DPC to be built in around all door and window openings.
- DPC to be SABS approved
- Wall ties built in every third brick course, wall ties spaced in staggered pattern at 2½ ties per m².
- Close the cavity at the top of the wall with two courses of solid brickwork.
- Return the inner leaf to stop unbonded against the outer leaf at sills, reveals and lintels.
- All internal window and door reveals to be plastered and painted.
- Precast concrete lintels over all door and window openings for up to 2m as to engineers specifications with 4 courses of brickwork over.
- Lintels to have end bearing of 230mm min. on each side
- Keep the cavity free of mortar droppings.

Drywall

- Gyproc 'Duraline' 15mm impact resistant Drywall consisting of stud and track system with 63,5mm Donn Drywall UltraSteel studs positioned at 600mm centres fixed into 63,5mm wide top and bottom track clad on both sides with 15mm thick Taper-edge Rhino-Plasterboard fixed with 4mm Drywall screws at 220mm centres and all corners fixed with 25 x 25mm corner beads and all joints to be taped with RhinoTape and as per manufacturer's specifications. Paintwork: Prepare and apply one coat Plascon plaster acrylic filler coat, fill with interior Polyfilla, sand and touch up filler coat and apply two full coats Plascon Wall and All - colour as per Architect

110mm and 230 Internal walls

- Provide and construct a new 230mm and 110mm brick wall as indicated on plan. The walls shall be built in approved clay stock bricks. Upon completion, apply 15mm cement plaster to all exposed faces, finished smooth to match adjacent wall surfaces. Apply One Coat Plascon Professional Plaster Primer (PP 700). Two Coats Plascon Wall and All Colour: as per Architect

COPYRIGHT NOTICE

This drawing is the confidential property of BNM ARCHITECTS and may not be disclosed to a third party, copied or reproduced in whole or in part without the permission of BNM ARCHITECTS

The contractor is to keep a full set of drawings on site. contractor is responsible for the correct setting out of the building on site with particular reference to boundaries and building lines, contractor to verify all levels and dimensions on site and check same against architects and engineers drawings before commencing work. Figured dimensions to be used in preference to scaled dimensions. large scale details to be used where available. errors, discrepancies or omissions are to be reported to the architect immediately for clarification before work is undertaken.

These drawings are to be read in conjunction with structural engineer's, civil engineer's, mechanical engineer's or plumbing consultant's drawings where specified.

All work and material used to comply with SABS standards and NATIONAL BUILDING REGULATIONS ACT 103 of 1977 and amendments thereto as well as the by-laws of the relevant local authority.

ALL WORK TO BE IN STRICT COMPLIANCE WITH SANS 10400

All new construction HEALTH AND SAFETY Regulations to be strictly complied with. A comprehensive Health & Safety Plan to be submitted to the Principal Agent/ Project Manager for review and monitoring.

date rev description

date	rev	description

notes

The contractor is to verify all dimensions on site before commencing any part of the work. Errors, discrepancies or omissions are to be reported for clarification.

BNM architects accept no responsibility for any construction proceeding prior to the granting of approval from the relevant local authority and / or interested party/ies.

BNM ARCHITECTS
PROJECT MANAGERS
19 milner street, utenhage
po box 686, utenhage 6230

(Pty) Ltd 2020/775519/07
tel: +27 41 992 5433
fax: +27 41 922 7124
email: bnmud@ud.bnm.co.za
web: www.bnm.co.za

Mossel Bay MUNICIPALITY

drawing name
SECTIONS

project details
PROPOSED NEW OFFICE BUILDING FOR SPCA K9 UNIT ON LEASE AREA NO 3 OVER THE REMAINDER OF ERF 2001 MOSSEL BAY

drawing number	revision
3260_B_06	

drawn	checked	scale	date
Marais	J.J. LOMBARD SACAP 6334 PROF. ARCH.	AS SHOWN	2026-04-10

PROFESSIONAL ARCHITECT
JACOBUS JOHANNES LOMBARD
0826 AM (Africa/Johannesburg) on 21 May 2025

client signature	architects signature

NOT FOR CONSTRUCTION, INFORMATION PURPOSES ONLY.

WINDOW SCHEDULE:	Window Type T1
	Quantity: 5
	Window description 900mm x 1825mm 'Wispeco' CREALCO "Swift 30.5" powder coated aluminium top hung with fixed bottom panel window.
	Colour: White
glazing	Smartglass "SolarVue Neutral HL" 6.38mm thick laminated safety glass (U Value 5.8 and SHGC 0.54).
ironmongery	as per manufacturer
Glazing shall be executed strictly in conformance with glass manufacturer's recommendations and all in accordance with National Building Regulations Parts B, N, T, SANS 10137, SANS 10400 and SANS 1263.	

WINDOW SCHEDULE:	Window Type T2
	Quantity: 8
	Window description 600mm x 600mm 'Wispeco' CREALCO "Swift 30.5" powder coated aluminium top hung window.
	Colour: White
glazing	Smartglass "SolarVue Neutral HL" 6.38mm thick laminated safety glass (U Value 5.8 and SHGC 0.54).
ironmongery	as per manufacturer
Glazing shall be executed strictly in conformance with glass manufacturer's recommendations and all in accordance with National Building Regulations Parts B, N, T, SANS 10137, SANS 10400 and SANS 1263.	

All Windows and Door to be in accordance with AAAMSA.
All Windows and Door to comply with:
SANS 10400 Part B,N and T
SANS 613 - Fenestration products: Mechanical/Structural performance criteria
SANS 10137 - The installation of glazing in buildings
SANS 1263 - Safety and security glazing materials for buildings

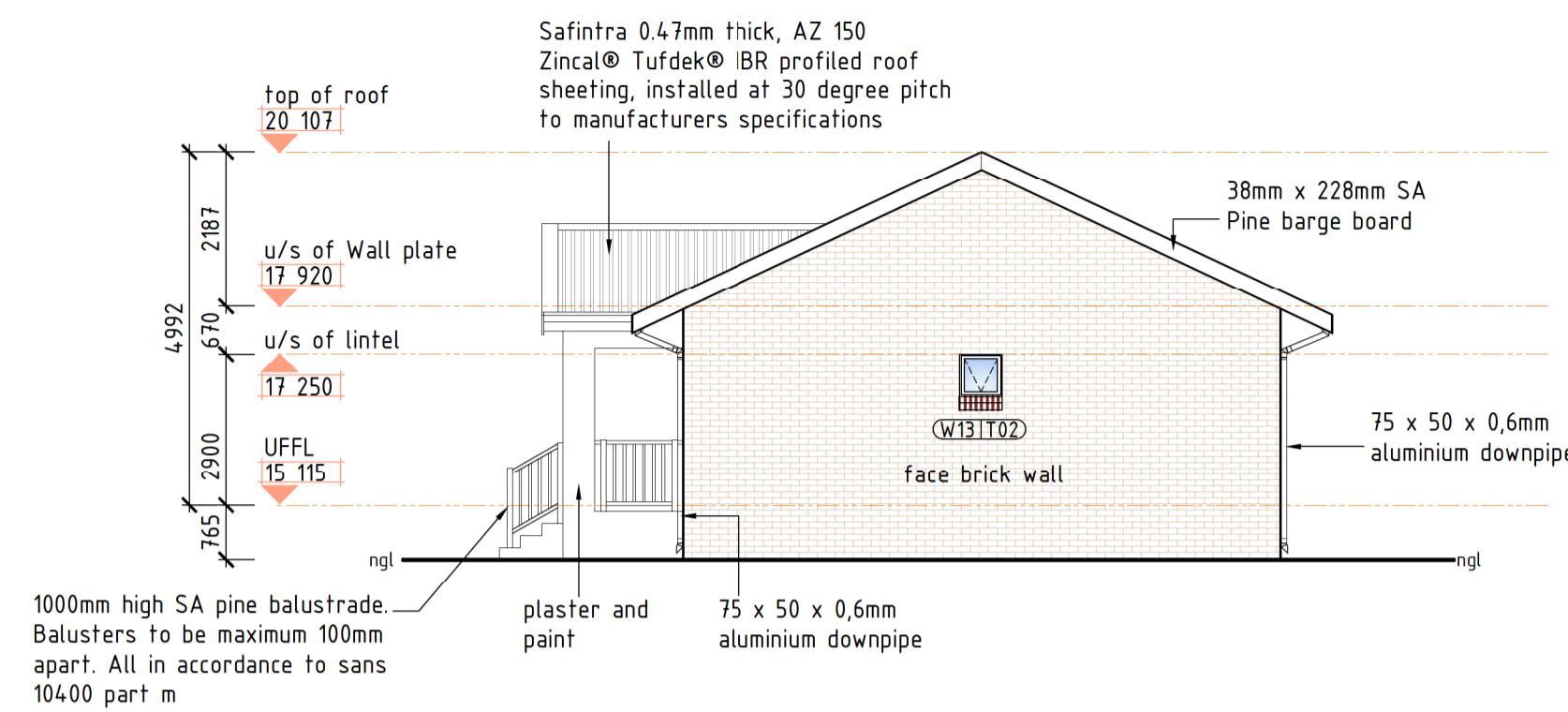

SOUTH EAST ELEVATION
SCALE 1 : 100

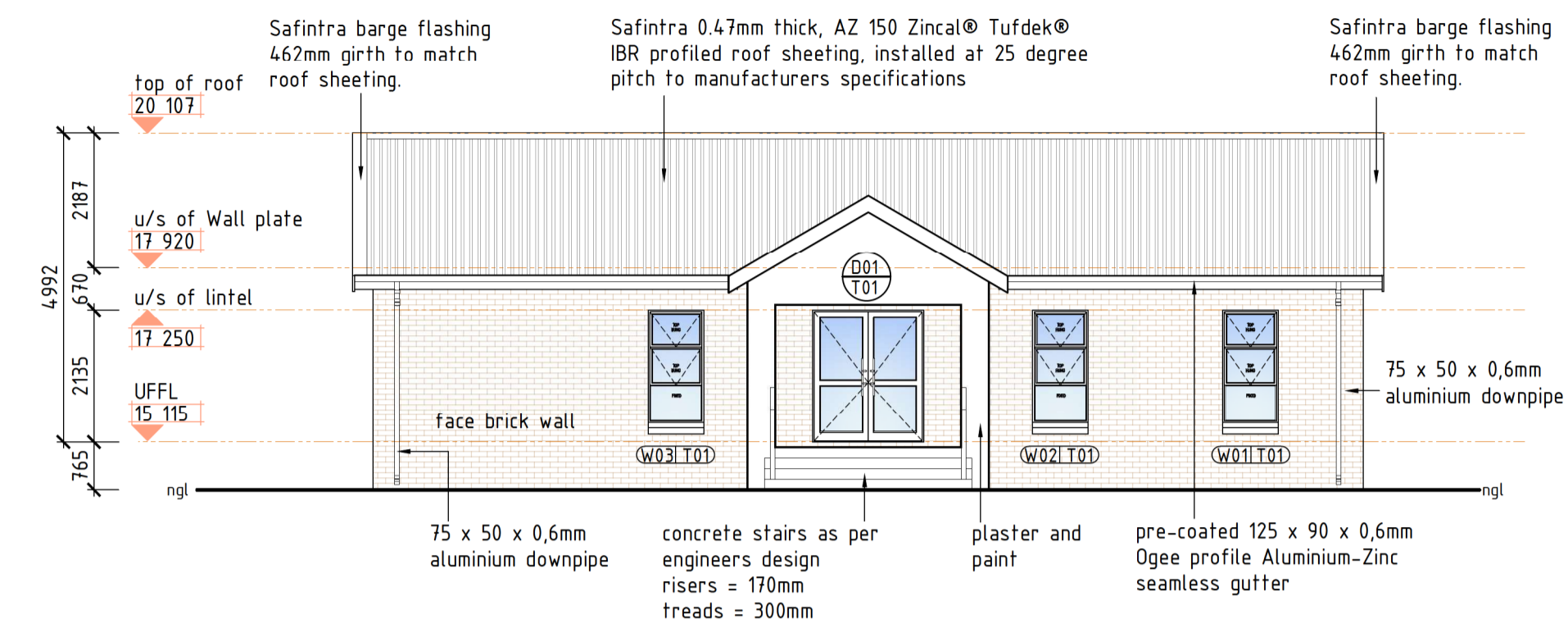

SOUTH WEST ELEVATION
SCALE 1 : 100

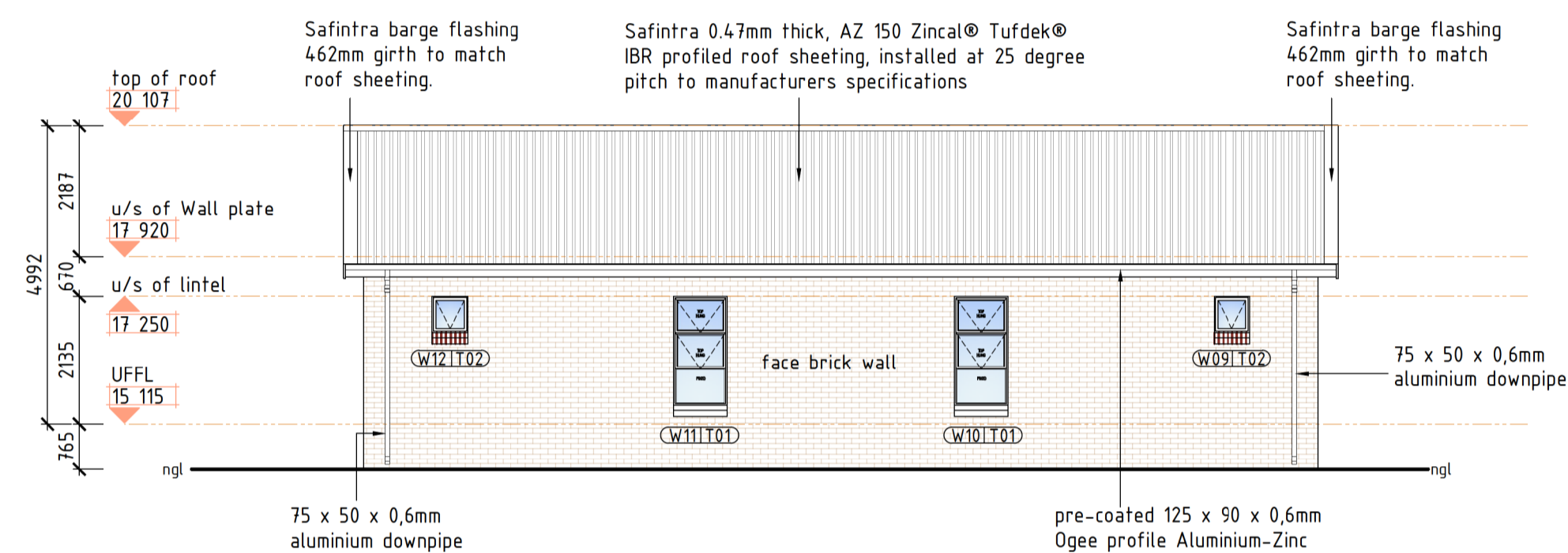

NORTH EAST ELEVATION
SCALE 1 : 100

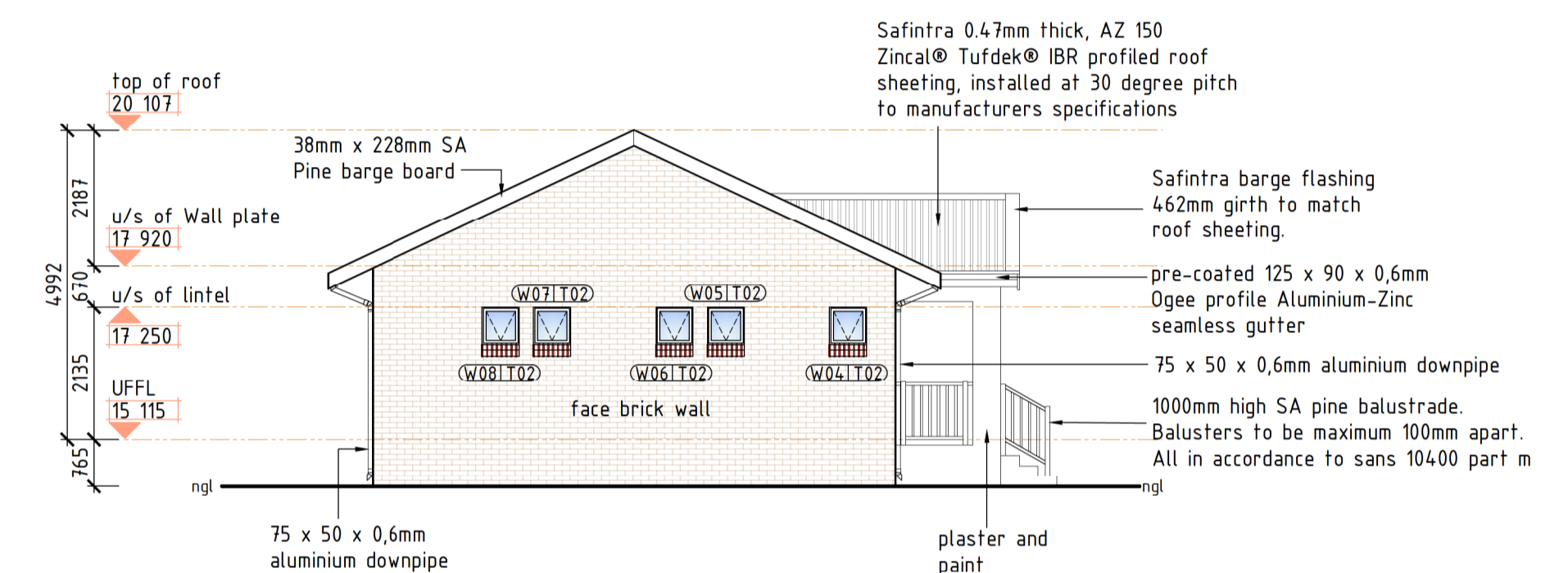

NORTH WEST ELEVATION
SCALE 1 : 100

NOTE: ALL ALUMINIUM SECTIONS SIZED AS APPROPRIATE BY GLAZED PARTITION MANUFACTURER / INSTALLER. ALL SETTING OUT MEASUREMENTS TO BE CONFIRMED BY CONTRACTOR / SUB-CONTRACTOR TO ACCURATE MANUFACTURE.

NOTE: SHOP DRAWINGS TO BE SUBMITTED FOR DISCUSSION AND APPROVAL, BEFORE MANUFACTURE COMMENCES. ANY DISCREPANCY OF LAYOUT TO BE BROUGHT TO THE ATTENTION OF THE ARCHITECT.

DOOR SCHEDULE:	Door Type T1
	Quantity: 1
	door description 1800 x 2125mm 'Wispeco' CREALCO "Clip 44" anodized (colour: natural) extruded aluminium hinged double door, with 90mm stiles and 85mm bottom and top rails.
	door frame and finish 'Wispeco' CREALCO "Clip44" anodized (colour: natural) extruded aluminium 75mm deep door frame profiles.
ironmongery	refer to ironmongery schedule
glazing	Smartglass "SolarVue Neutral HL" 6.38mm thick laminated safety glass (U Value 5.8 and SHGC 0.54).
Glazing shall be executed strictly in conformance with glass manufacturer's recommendations and all in accordance with National Building Regulations Parts B, N, T, SANS 10137, SANS 10400 and SANS 1263.	

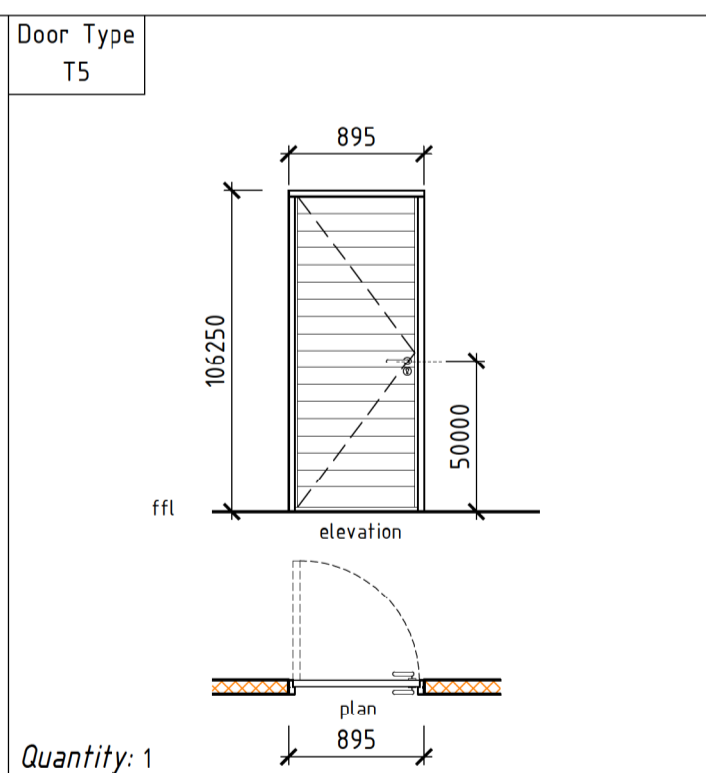
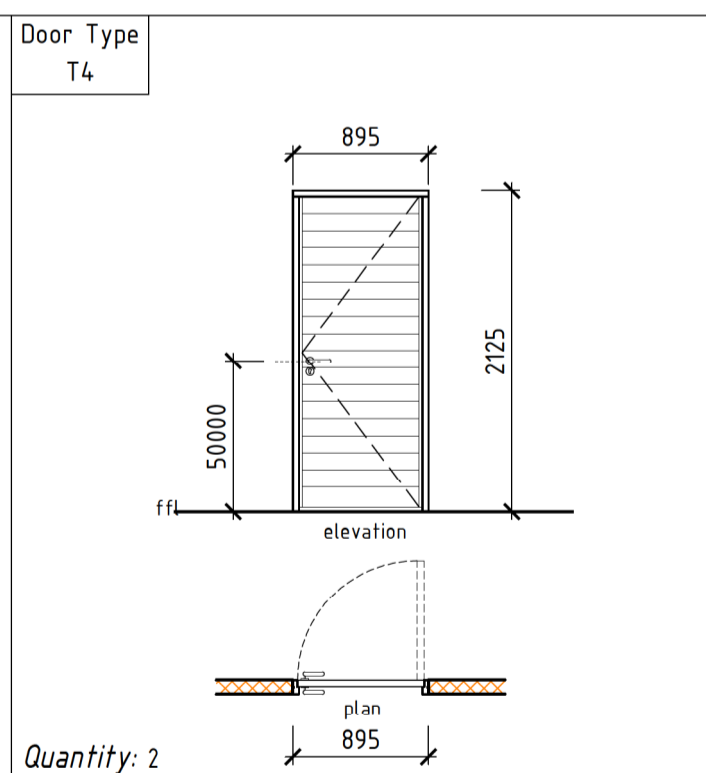
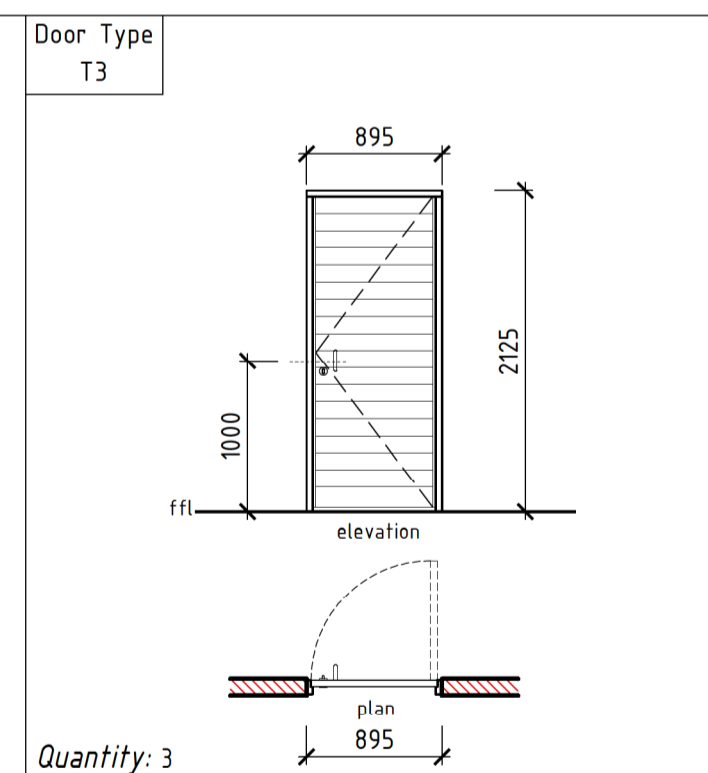
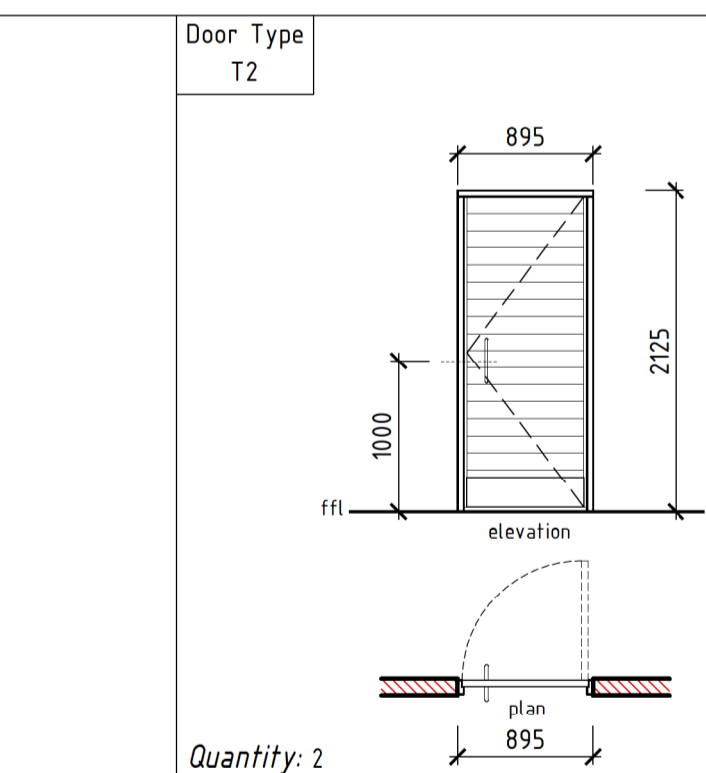

EXTERNAL WALLS	
Required specification	R≥0.60
Actual specification	270 face brick wall R≥0.60

FENESTRATION COMPLIANCE WITH SANS 10400-XA (2021)			
City	Mossel bay	Storey	1
Latitude	34.13	Total storey net internal floor area (m²)	122.00

BUILDING & FENEST'R N	FENESTRATION AREAS				
	ORIENTATION	window width	window vertical	number (quantity)	window area m²
T2	W,NW,N,NE,E sector	600	600	7	2.52
T1	W,NW,N,NE,E	900	1825	2	3.29
Total W,NW,N,NE,E orientated fenest'n area					5.81
D1	SW,S,SE	1800	2125	1	3.83
T1	SW,S,SE	900	1825	3	4.93
T2	SW,S,SE	600	600	1	0.36
Storey total fenestration area					14.92
Storey net internal floor area b / f					122.00
%					12.23
Fenestration Compliant IF % > 20%					Compliant

All opening dimensions to be verify on-site prior to starting manufacturing.

NOT FOR CONSTRUCTION, INFORMATION PURPOSES ONLY.

COPYRIGHT NOTICE

This drawing is the confidential property of BNM ARCHITECTS and may not be disclosed to a third party, copied or reproduced in whole or in part without the permission of BNM ARCHITECTS

The contractor is to keep a full set of drawings on site, contractor is responsible for the correct setting out of the building on site with particular reference to boundaries and building lines, contractor to verify all levels and dimensions on site and check same against architects and engineers drawings before commencing work. Figured dimensions to be used in preference to scaled dimensions, large scale details to be used where available, errors, discrepancies or omissions are to be reported to the architect immediately for clarification before work is undertaken.

These drawings are to be read in conjunction with structural engineer's, civil engineer's, mechanical engineer's or plumbing consultant's drawings where specified.

All work and material used to comply with SABS standards and NATIONAL BUILDING REGULATIONS ACT 103 of 1977 and amendments thereto as well as the by-laws of the relevant local authority.

ALL WORK TO BE IN STRICT COMPLIANCE WITH SANS 10400

All new construction HEALTH AND SAFETY Regulations to be strictly complied with. A comprehensive Health & Safety Plan to be submitted to the Principal Agent/ Project Manager for review and monitoring.

date rev description

date	rev	description

notes

The contractor is to verify all dimensions on site before commencing any part of the work. Errors, discrepancies or omissions are to be reported for clarification.

BNM architects accept no responsibility for any construction proceeding prior to the granting of approval from the relevant local authority and / or interested party/ies.

BNM ARCHITECTS PROJECT MANAGERS (Pty)Ltd 2020/775519/07
19 milner street, uitenhage po box 686, uitenhage 6230
tel: +27 41 992 5433 fax: +27 41 922 7124 email: bnmud@ud.bnm.co.za web: www.bnm.co.za

Mossel Bay MUNICIPALITY

drawing name
ELEVATIONS, WINDOW AND DOOR SCHEDULES

project details
PROPOSED NEW OFFICE BUILDING FOR SPCA K9 UNIT ON LEASE AREA NO 3 OVER THE REMAINDER OF ERF 2001 MOSSSEL BAY

drawing number		revision	
3260_B_07			
drawn	checked	scale	date
Marais	J.J. LOMBARD	AS SHOWN	2026-04-10
SACAP 6334		PROF. ARCH	

PROFESSIONAL ARCHITECT
JACOBUS JOHANNES LOMBARD
0826 AM (Africa/Johannesburg) on 21 May 2025

client signature architects signature