

# NEC3 Supply Contract (SC3)

Between **ESKOM ROTEK INDUSTRIES SOC Ltd**  
(Reg No. 1990/006897/30)

and -----  
(-----)

for **THE SUPPLY AND MANUFACTURE OF COUPLING,  
JIG PLATES AND ACCESSORIES**

---

| <b>Contents:</b>                   | <b>No of pages</b> |
|------------------------------------|--------------------|
| Part C1 Agreements & Contract Data | [•]                |
| Part C2 Pricing Data               | [•]                |
| Part C3 Scope of Work              | [•]                |

---

**CONTRACT No. [Insert at award stage]**

---

## PART C1: AGREEMENTS & CONTRACT DATA

---

| <b>Contents:</b>  | <b>No of pages</b> |
|---|--------------------|
| <b>C1.1 Form of Offer and Acceptance</b>                    | <b>[•]</b>         |
| [to be inserted from Returnable Documents at award stage]   |                    |
| <b>C1.2a Contract Data provided by the <i>Purchaser</i></b> | <b>[•]</b>         |
| <b>C1.2b Contract Data provided by the <i>Supplier</i></b>  | <b>[•]</b>         |
| [to be inserted from Returnable Documents at award stage]   |                    |
| <b>C1.3 Proforma Guarantees</b>                             | <b>[•]</b>         |

---

# C1.1 Form of Offer & Acceptance

## Offer

The Purchaser, identified in the Acceptance signature block, has solicited offers to enter into a contract for the procurement of:

### THE SUPPLY AND MANUFACTURE OF COUPLING, JIG PLATES AND ACCESSORIES

The tenderer, identified in the Offer signature block, has

|               |   |
|---------------|---|
| <i>either</i> | examined the documents listed in the Tender Data and addenda thereto as listed in the Returnable Schedules, and by submitting this Offer has accepted the Conditions of Tender. |
| <i>or</i>     | examined the draft contract as listed in the Acceptance section and agreed to provide this Offer.   |

By the representative of the tenderer, deemed to be duly authorised, signing this part of this Form of Offer and Acceptance the tenderer offers to perform all of the obligations and liabilities of the *Supplier* under the contract including compliance with all its terms and conditions according to their true intent and meaning for an amount to be determined in accordance with the *conditions of contract* identified in the Contract Data.

|  |  |  |
|--|--|--|
|  | The offered total of the Prices exclusive of VAT is                  |  |
|  | Value Added Tax @ 15% is   |  |
|  | The offered total of the amount due inclusive of VAT is <sup>1</sup> |  |
|  | <b>including VAT.</b>  |  |

This Offer may be accepted by the Purchaser by signing the Acceptance part of this Form of Offer and Acceptance and returning one copy of this document including the Schedule of Deviations (if any) to the tenderer before the end of the period of validity stated in the Tender Data, or other period as agreed, whereupon the tenderer becomes the party named as the *Supplier* in the *conditions of contract* identified in the Contract Data.

Signature(s)

Name(s)

Capacity

**For the tenderer:**

(Insert name and address of organisation)

Name & signature of witness

Date

<sup>1</sup> This total is required by the *Purchaser* for budgeting purposes only. Actual amounts due will be assessed in terms of the *conditions of contract*.

## Acceptance

By signing this part of this Form of Offer and Acceptance, the Purchaser identified below accepts the tenderer's Offer. In consideration thereof, the Purchaser shall pay the Supplier the amount due in accordance with the *conditions of contract* identified in the Contract Data. Acceptance of the tenderer's Offer shall form an agreement between the Purchaser and the tenderer upon the terms and conditions contained in this agreement and in the contract that is the subject of this agreement.

The terms of the contract, are contained in:

- Part C1            Agreements and Contract Data, (which includes this Form of Offer and Acceptance)
- Part C2            Pricing Data
- Part C3            Scope of Work: Goods Information including Supply Requirements

and drawings and documents (or parts thereof), which may be incorporated by reference into the above listed Parts.

Deviations from and amendments to the documents listed in the Tender Data and any addenda thereto listed in the Returnable Schedules as well as any changes to the terms of the Offer agreed by the tenderer and the Purchaser during this process of offer and acceptance, are contained in the Schedule of Deviations attached to and forming part of this Form of Offer and Acceptance. No amendments to or deviations from said documents are valid unless contained in this Schedule.

The tenderer shall within two weeks of receiving a completed copy of this agreement, including the Schedule of Deviations (if any), contact the Purchaser's agent (whose details are given in the Contract Data) to arrange the delivery of any securities, bonds, guarantees, proof of insurance and any other documentation to be provided in terms of the *conditions of contract* identified in the Contract Data at, or just after, the date this agreement comes into effect. Failure to fulfil any of these obligations in accordance with those terms shall constitute a repudiation of this agreement.

Notwithstanding anything contained herein, this agreement comes into effect on the date when the tenderer receives one fully completed and signed original copy of this document, including the Schedule of Deviations (if any).

Signature(s)

Name(s)

Capacity

for the  
Purchaser

**Eskom Rotek Industries SOC Ltd**  
**Lower Germiston Road,**  
**Cleveland**  
**Johannesburg**  
**2022**

*(Insert name and address of organisation)*

Name &  
signature of  
witness

Date

Note: If a tenderer wishes to submit alternative tenders, use another copy of this Form of Offer and Acceptance.

**Schedule of Deviations to be completed by the *Purchaser* prior to contract award**

Note:

1. This part of the Offer & Acceptance would not be required if the contract has been developed by negotiation between the Parties and is not the result of a process of competitive tendering.
2. The extent of deviations from the tender documents issued by the Purchaser prior to the tender closing date is limited to those permitted in terms of the Conditions of Tender.
3. A tenderer's covering letter must not be included in the final contract document. Should any matter in such letter, which constitutes a deviation as aforesaid be the subject of agreement reached during the process of Offer and Acceptance, the outcome of such agreement shall be recorded here and the final draft of the contract documents shall be revised to incorporate the effect of it.

| No. | Subject | Details |
|-----|---------|---------|
| 1   | [•]     | [•]     |
| 2   | [•]     | [•]     |
| 3   | [•]     | [•]     |
| 4   | [•]     | [•]     |
| 5   | [•]     | [•]     |
| 6   | [•]     | [•]     |
| 7   | [•]     | [•]     |

By the duly authorised representatives signing this Schedule of Deviations below, the Purchaser and the tenderer agree to and accept this Schedule of Deviations as the only deviations from and amendments to the documents listed in the Tender Data and any addenda thereto listed in the Tender Schedules, as well as any confirmation, clarification or changes to the terms of the Offer agreed by the tenderer and the Purchaser during this process of Offer and Acceptance.

It is expressly agreed that no other matter whether in writing, oral communication or implied during the period between the issue of the tender documents and the receipt by the tenderer of a completed signed copy of this Form shall have any meaning or effect in the contract between the parties arising from this Agreement.

**For the tenderer:**

**For the Purchaser**

|  |  |
|--|--|
| Signature _____<br>Name _____<br>Capacity _____<br>On behalf of _____<br>Name & signature of witness _____<br>Date _____ | _____<br>_____<br>_____<br><b>Eskom Rotek Industries SOC Ltd</b><br><b>Lower Germiston Road,</b><br><b>Cleveland</b><br><b>Johannesburg</b><br><b>2022</b><br>_____<br>_____ |
|--|--|

# C1.2 SC3 Contract Data

## Part one - Data provided by the *Purchaser*.

[Instructions to the contract compiler: (delete these two notes in the final draft of a contract)]

1. Please read the relevant clauses in the conditions of contract before you enter data. The number of the clause which requires the data is shown in the left hand column for each statement however other clauses may also use the same data.
2. Some SC3 options are always selected by Eskom Holdings SOC Ltd. The remaining SC3 options are identified by shading in the left hand column. In the event that the option is not required select and delete the whole row. Where the following symbol is used “[●]” - data is required to be inserted relevant to the specific option selected.]

Completion of this data in full, according to the Options chosen, is essential to create a complete contract.

| Cla use | Statement  | Data  |
|---------|--|---|
| 1       | <b>General</b>   |   |
|         | <p>The <i>conditions of contract</i> are the core clauses and the clauses for Options</p> <p>of the NEC3 Supply Contract (April 2013) <sup>2</sup></p> | <p><b>X1: Price adjustment for inflation</b></p> <p><b>X2 Changes in the law</b></p> <p><b>X3: Multiple currencies</b></p> <p><b>X7: Delay damages</b></p> <p><b>X17: Low performance damages</b></p> <p><b>X20: Key Performance Indicators</b></p> <p><b>Z: Additional conditions of contract</b></p> <p>(If the December 2009 edition is to be used delete April 2013 and replace by December 2013)</p> |
| 10.1    | <p>The <i>Purchaser</i> is (name):</p> <p>Address</p> <p>Tel No.</p>   | <p><b>Eskom Rotek Industries SOC Ltd</b><br/> <b>(Reg no: 1990/006897/30), a state owned company</b><br/> <b>incorporated in terms of the company laws of the</b><br/> <b>Republic of South Africa</b></p> <p><b>Lower Germiston Road</b><br/> <b>Rosherville</b><br/> <b>Cleveland</b><br/> <b>Johannesburg</b><br/> <b>2022</b></p> <p><b>011 629 4000</b></p>  |
| 10.1    | The <i>Supply Manager</i> is (name):   | [●]   |

<sup>2</sup> Available from Engineering Contract Strategies Tel 011 803 3008 Fax 086 539 1902, www.ecs.co.za.

|          |  |  |
|----------|--|--|
|          | Address  | [•]  |
|          | Tel  | [•]  |
|          | Fax  | [•]  |
|          | e-mail   | [•]  |
| 11.2(13) | The <i>goods</i> are   | <b>Supply and manufacture of coupling , jig plate and accessories as described in the SOW Part 3 of this document</b>  |
| 11.2(13) | The <i>services</i> are  | <b>The supply and manufacture of coupling , jig plate and accessories</b>  |
| 11.2(14) | The following matters will be included in the Risk Register  | <b>Not applicable</b>  |
| 11.2(15) | The Goods Information is in  | <b>Part 3: Scope of Work and all documents and drawings to which it makes reference.</b>   |
| 11.2(15) | The Supply Requirements as part of the Goods Information is in   | <b>Annexure A to this Contract Data</b>  |
| 12.2     | The <i>law of the contract</i> is the law of   | <b>the Republic of South Africa</b>  |
| 13.1     | The <i>language of this contract</i> is  | <b>English</b>   |
| 13.3     | The <i>period for reply</i> is   | <b>8 Hours to acknowledge receipt of communication and 2 days to respond</b>   |
| <b>2</b> | <b>The <i>Supplier's</i> main responsibilities</b>   | <b>Data required by this section of the core clauses is provided by the <i>Supplier</i> in Part 2 and terms in italics used in this section are identified elsewhere in this Contract Data.</b>                        |
| <b>3</b> | <b>Time</b>  |  |
| 30.1     | The <i>starting date</i> is.   | <b>Date of Signature of contract and issue of the official order.<br/>The individual Task order dates will stipulate start and end dates, this will apply per SOW and must be mutually agreed between both parties</b> |
| 30.1     | The <i>delivery date</i> of the <i>goods</i> is:   | <b>On receipt of official order.<br/>To be mutually agreed by both parties</b>   |
| 30.2     | The <i>Supplier</i> does not bring the <i>goods</i> to the Delivery Place more than one week before the Delivery Date. | <b>DDP ex works Rosherville</b>  |
| 31.1     | The <i>Supplier</i> is to submit a first programme for acceptance within   | <b>[1] weeks of the Contract Date.</b>   |
| 32.2     | The <i>Supplier</i> submits revised programmes at intervals no longer than   | <b>2 days</b>  |
| <b>4</b> | <b>Testing and defects</b>   |  |
| 42       | The <i>defects date</i> is   | <b>52 weeks after the completion of each task order.<br/>The time to respond to a defect's notification will be</b>  |

|           |  |   |
|-----------|--|---|
|           |  | <b>2 calendar days.</b>   |
| 43.2      | The <i>defect correction period</i> is   | <b>Not Applicable</b>   |
| 42.2      | The <i>defects access period</i> is  | <b>Not Applicable</b>   |
| <b>5</b>  | <b>Payment</b>   |   |
| 50.1      | The <i>assessment interval</i> is  | <p><b>As stated on each individual Task Order.</b></p> <p><b>It must be noted that payment will be made on actual delivery completed. The assessment certificate must be signed by the relevant Project Manager and the Contractor’s representative, upon agreement. This certificate must accompany the tax invoice.</b></p>   |
| 51.1      | The <i>currency of this contract</i> is the                                      | <b>South African Rand</b>   |
| 51.2      | The period within which payments are made is                                     | <b>Within 60 days of receipt of the Contractor’s tax compliant invoice</b>  |
| 51.4      | The <i>interest rate</i> is  | <b>Zero percent above the publicly quoted prime rate of interest (calculated on a 365 day year) charged by from time to time by the Standard Bank of South Africa Limited (as certified, in the event of any dispute, by any manager of such bank, whose appointment it shall not be necessary to prove) for amounts due in</b> |
| <b>6</b>  | <b>Compensation events</b>   | <b>Any additional scope that was not catered for in the tender.</b>   |
| <b>7</b>  | <b>Title</b>   | <b>There is no reference to Contract Data in this section of the core clauses and terms in italics used in this section are identified elsewhere in this Contract Data.</b>   |
| <b>80</b> | <b>Risks and Insurance</b>   |   |
| 80.1      | These are additional <i>Purchaser’s</i> risks                                    | <b>None</b>   |
| 83.1      | The <i>Employer</i> provides the insurances stated in the Insurance Table below. |   |
|           | <b>INSURANCE TABLE</b>   |   |
|           | <b>Insurance against</b>   | <b>Minimum amount of cover or minimum limit of indemnity as stated for “Format TSC3” available on</b>   |
|           | Assets All Risk  | As per the insurance policy document.   |
|           | Project insurance  | As per the insurance policy document.   |
|           | General and Public Liability   | As per the insurance policy document.   |
|           | Environmental Liability  | As per the insurance policy document.   |
|           | Transport (Marine)   | As per the insurance policy document.   |
|           | Motor Fleet and Mobile Plant   | As per the insurance policy document.   |
|           | Terrorism  | As per the insurance policy document.   |
|           | Cyber Liability  | As per the insurance policy document.   |

83.1 The *Contractor* provides the insurances stated in the Insurance Table

The insurances provide cover for events which are at the *Contractor's* risk from the *starting date* until the end of the *service period* or a termination certificate has been issued

**INSURANCE TABLE**

| <b>Insurance against</b>  | <b>Minimum amount of cover or minimum limit of indemnity</b>   |
|---|--|
| Loss of or damage caused by the <i>Contractor</i> to the <i>Employer's</i> property   | The replacement cost where not covered by the <i>Employer's</i> insurance.<br><br>The <i>Employer's</i> policy deductible as at contract date, where covered by the <i>Employer's</i> insurance. |
| Loss of or damage to Plant and Materials  | The replacement cost where not covered by the <i>Employer's</i> insurance.<br><br>The <i>Employer's</i> policy deductible as at contract date, where covered by the <i>Employer's</i> insurance. |
| Loss of or damage to Equipment  | The replacement cost where not covered by the <i>Employer's</i> insurance.<br><br>The <i>Employer's</i> policy deductible as at contract date, where covered by the <i>Employer's</i> insurance. |
| The <i>Contractor's</i> liability for loss of or damage to property (except the <i>Employer's</i> property, Plant and Materials and Equipment) and liability for bodily injury to or death of a person (not an employee of the <i>Contractor</i> ) arising from or in connection with the <i>Contractor's</i> Providing the Service | <b><u>Loss of or damage to property</u></b><br>The replacement cost<br><br><b><u>Bodily injury to or death of a person</u></b><br>The amount required by the applicable law.                     |
| Liability for death of or bodily injury to employees of the <i>Contractor</i> arising out of and in the course of their employment in connection with this contract   | The amount required by the applicable law  |

**9 Termination**

|             |   |
|-------------|---|
| <b>90.1</b> | The Employer may terminate the Contract for any reason suffice that the reason given by the Employer complies with this contract and is in terms of clause 90.1." |
| <b>90.2</b> | In terms of clause 90.2 of the <i>conditions of contract</i> , the <i>Employer</i> may terminate for any reason other than R1-R21.                                |
| <b>90.3</b> | Will apply in respect of payment.<br>All outstanding invoices and Delivery notes will be required by the Employer.  |

94.1 The *Adjudicator* is **the person selected from the ICE-SA Division (or its successor body) of the South African Institution of Civil Engineering Panel of Adjudicators by the Party intending to refer a dispute to him. (see [www.ice-sa.org.za](http://www.ice-sa.org.za)). If the Parties do not agree on an Adjudicator the Adjudicator will be appointed by the Arbitration Foundation of Southern Africa**

|           |   |   |                     |   |
|-----------|---|---|---------------------|---|
|           |   | (AFSA).   |                     |   |
|           | Address   | [•]   |                     |   |
|           | Tel No.   | [•]   |                     |   |
|           | Fax No.   | [•]   |                     |   |
|           | e-mail  | [•]   |                     |   |
| 94.2(3)   | The <i>Adjudicator nominating body</i> is:                                  | the Chairman of ICE-SA, a Division of the South African Institution of Civil Engineering, or its successor body (See <a href="http://www.ice-sa.org.za">www.ice-sa.org.za</a> ) |                     |   |
| 94.4(2)   | The <i>tribunal</i> is:   | arbitration   |                     |   |
| 94.4(5)   | The <i>arbitration procedure</i> is   | the latest edition of Rules for the Conduct of Arbitrations published by The Association of Arbitrators (Southern Africa) or its successor body.                                |                     |   |
| 94.4(5)   | The place where arbitration is to be held is                                | [•] South Africa  |                     |   |
|           | The person or organisation who will choose an arbitrator                    |   |                     |   |
|           | - if the Parties cannot agree a choice or                                   |   |                     |   |
|           | - if the arbitration procedure does not state who selects an arbitrator, is |   |                     | the Chairman for the time being or his nominee of the Association of Arbitrators (Southern Africa) or its successor body. |
| <b>10</b> | <b>Data for Option clauses</b>  |   |                     |   |
| <b>X1</b> | <b>Price adjustment for inflation</b>                                       |   |                     |   |
| X1.1      | The <i>base date</i> for indices is   | [•].  |                     |   |
|           | The proportions used to calculate the Price Adjustment Factor are:          | proportion  | linked to index for | Index prepared by   |
|           |   | 0.  | [•]                 | [•]   |
|           |   | 0.  | [•]                 | [•]   |
|           |   | 0.  | [•]                 | [•]   |
|           |   | 0.  | [•]                 | [•]   |
|           |   | 0.  | [•]                 | [•]   |
|           |   | [•]   | non-adjustable      |   |
|           |   | 1.00  |                     |   |
| <b>X2</b> | <b>Changes in the law</b>   |   |                     |   |
| X2.1      | A change in the law of  | [•] is a compensation event if it occurs after the Contract Date  |                     |   |
| <b>X3</b> | <b>Multiple currencies</b>  |   |                     |   |
| X3.1      | The <i>Purchaser</i> will pay for these items in the currencies stated      | Items   | Other               | Total maximum payment in the  |

|  |  |  |   |  |
|--|--|--|---|--|
| X3.1   | The <i>exchange rates</i> are those published in   | <p>[•]<br/>[•]<br/>[•]<br/>[•] on [•] (date)</p> <p>The items will be paid in the other currency<br/>- to a foreign Bank account nominated by the <i>Supplier</i><br/>- to a valid SARB approved CFC account in South Africa<br/>- in accordance with an alternative payment method agreed with the <i>Purchaser</i> before the Contract Date.</p> <p>(select one of the three methods as agreed with the successful tenderer prior to contract award and delete the others and this note)</p> | currency                                | currency   |
| <b>X7 Delay damages</b>  |  |  |   |  |
| X7.1   | Delay damages for Delivery are   | <p><b>Delivery of Tools</b></p> <p>5 % of the Task Order value</p>   | amount per day                          | <p>1 % per day to a maximum of 5% of the Task Order value</p>  |
| <b>X17 Low performance damages</b>                                       |  |  |   |  |
| X17.1  | The amounts for low performance damages are:   | <p>amount</p> <p>R [•]<br/>R [•]<br/>R [•]<br/>R [•]</p>   | performance level                       | <p>1 % per day to a maximum of 5% of the Task Order value</p> <p>for [•]<br/>for [•]<br/>for [•]</p> |
| <b>X20 Key Performance Indicators (not used when Option X12 applies)</b> |  |  |   |  |
| X20.1  | The <i>incentive schedule</i> for Key Performance Indicators is in                         | Annexure [•] to this Contract Data   |   |  |
| X20.2  | A report of performance against each Key Performance Indicator is provided at intervals of | [•] months   |   |  |
| <b>Z</b>   | <b>The <i>additional conditions of contract</i> are</b>                                    |  | <b>Z1 to Z12 always apply for Eskom</b> |  |

**Z1 Cession delegation and assignment**

- Z1.1 The *Supplier* does not cede, delegate or assign any of its rights or obligations to any person without the written consent of the *Purchaser*.
- Z1.2 Notwithstanding the above, the *Purchaser* may on written notice to the *Supplier* cede and delegate its rights and obligations under this contract to any of its subsidiaries or any of its present divisions or operations which may be converted into separate legal entities as a result of the restructuring of the Electricity Supply Industry.

**Z2 Joint ventures**

- Z2.1 If the *Supplier* constitutes a joint venture, consortium or other unincorporated grouping of two or more persons or organisations then these persons or organisations are deemed to be jointly and severally liable to the *Purchaser* for the performance of this contract.
- Z2.2 Unless already notified to the *Purchaser*, the persons or organisations notify the *Supply Manager* within two weeks of the Contract Date of the key person who has the authority to bind the *Supplier* on their behalf.
- Z2.3 The *Supplier* does not alter the composition of the joint venture, consortium or other unincorporated grouping of two or more persons without the consent of the *Purchaser* having been given to the *Supplier* in writing.

**Z3 Change of Broad Based Black Economic Empowerment (B-BBEE) status**

- Z3.1 Where a change in the *Supplier's* legal status, ownership or any other change to his business composition or business dealings results in a change to the *Supplier's* B-BBEE status, the *Supplier* notifies the *Purchaser* within seven days of the change.
- Z3.2 The *Supplier* is required to submit an updated verification certificate and necessary supporting documentation confirming the change in his B-BBEE status to the *Supply Manager* within thirty days of the notification or as otherwise instructed by the *Supply Manager*.
- Z3.3 Where, as a result, the *Supplier's* B-BBEE status has decreased since the Contract Date the *Purchaser* may either re-negotiate this contract or alternatively, terminate the *Supplier's* obligation to Provide the Goods and Services.
- Z3.4 Failure by the *Supplier* to notify the *Purchaser* of a change in its B-BBEE status may constitute a reason for termination. If the *Purchaser* terminates in terms of this clause, the procedures on termination are P1, P2 and P3 as stated in clause 92, and the amount due is A1 and A3 as stated in clause 93.

**Z4 Ethics**

- Z4.1 Any offer, payment, consideration, or benefit of any kind made by the *Supplier*, which constitutes or could be construed either directly or indirectly as an illegal or corrupt practice, as an inducement or reward for the award or in execution of this contract constitutes grounds for terminating the *Supplier's* obligation to Provide the Goods and Services or taking any other action as appropriate against the *Supplier* (including civil or criminal action).
- Z4.2 The *Purchaser* may terminate the *Supplier's* obligation to Provide the Goods and Services if the *Supplier* (or any member of the *Supplier* where the *Supplier* constitutes a joint venture, consortium or other unincorporated grouping of two or more persons or organisations) is found guilty by a competent court, administrative or regulatory body of participating in illegal or corrupt practices.

Such practices include making of offers, payments, considerations, or benefits of any kind or otherwise, whether in connection with any procurement process or contract with the *Purchaser* or other people or organisations and including in circumstances where the *Supplier* or any such member is removed from

the an approved vendor data base of the *Purchaser* as a consequence of such practice.

- Z4.3 Notwithstanding the provisions of core clause 90.2, the procedures on termination in terms of this clause are P1, P2 and P3 as stated in the core clause 92 and the amount due is A1 and A3 as stated in core clause 93.

## Z5 Confidentiality

- Z5.1 The *Supplier* does not disclose or make any information arising from or in connection with this contract available to Others. This undertaking does not, however, apply to information which at the time of disclosure or thereafter, without default on the part of the *Supplier*, enters the public domain or to information which was already in the possession of the *Supplier* at the time of disclosure (evidenced by written records in existence at that time). Should the *Supplier* disclose information to Others in terms of clause 23.1, the *Supplier* ensures that the provisions of this clause are complied with by the recipient.
- Z5.2 If the *Supplier* is uncertain about whether any such information is confidential, it is to be regarded as such until notified otherwise by the *Supply Manager*.
- Z5.3 In the event that the *Supplier* is, at any time, required by law to disclose any such information which is required to be kept confidential, the *Supplier*, to the extent permitted by law prior to disclosure, notifies the *Purchaser* so that an appropriate protection order and/or any other action can be taken if possible, prior to any disclosure. In the event that such protective order is not, or cannot, be obtained, then the *Supplier* may disclose that portion of the information which it is required to be disclosed by law and uses reasonable efforts to obtain assurances that confidential treatment will be afforded to the information so disclosed.
- Z5.4 The taking of images (whether photographs, video footage or otherwise) of the *goods* or any portion thereof, in the course of Providing the Goods and Services and after Delivery, requires the prior written consent of the *Supply Manager*. All rights in and to all such images vests exclusively in the *Purchaser*.
- Z5.5 The *Supplier* ensures that all his subcontractors abide by the undertakings in this clause.

## Z6 Waiver and estoppel: Add to core clause 12.3:

- Z6.1 Any extension, concession, waiver or relaxation of any action stated in this contract by the Parties, the *Supply Manager* or the *Adjudicator* does not constitute a waiver of rights, and does not give rise to an estoppel unless the Parties agree otherwise and confirm such agreement in writing.

## Z7 Health, safety and the environment: Add to core clause 25.4

- Z7.1 The *Supplier* undertakes to take all reasonable precautions to maintain the health and safety of persons in and about the provision of the *goods* and execution of the *services*.

Without limitation the *Supplier*:

- warrants that the total of the Prices as at the Contract Date includes a sufficient amount for proper compliance with all applicable health & safety laws and regulations and the health and safety rules, guidelines and procedures provided for in this contract and generally for the proper maintenance of health & safety in and about the execution of supply and
- undertakes, in and about the execution of the supply, to comply with all applicable health & safety laws and regulations and rules, guidelines and procedures otherwise provided for under this contract and ensures that his Subcontractors, employees and others under the *Supplier's* direction and control, likewise observe and comply with the foregoing.

- Z7.2 The *Supplier*, in and about the execution of the supply, complies with all applicable environmental laws and regulations and rules, guidelines and procedures otherwise provided for under this contract and ensures that his Subcontractors, employees and others under the *Supplier's* direction and control,

likewise observe and comply with the foregoing.

**Z8 Provision of a Tax Invoice and interest. Add to core clause 51**

- Z8.1 Within one week of receiving a payment certificate from the *Supply Manager* in terms of core clause 51.1, the *Supplier* provides the *Purchaser* with a tax invoice in accordance with the *Purchaser's* procedures stated in the Goods Information, showing the amount due for payment equal to that stated in the payment certificate.
- Z8.2 If the *Supplier* does not provide a tax invoice in the form and by the time required by this contract, the time by when the *Purchaser* is to make a payment is extended by a period equal in time to the delayed submission of the correct tax invoice. Interest due by the *Purchaser* in terms of core clause 51.2 is then calculated from the delayed date by when payment is to be made.
- Z8.3 The *Supplier* (if registered in South Africa in terms of the companies Act) is required to comply with the requirements of the Value Added Tax Act, no 89 of 1991 (as amended) and to include the *Purchaser's* VAT number 4330196330 on each invoice he submits for payment.

**Z9 Notifying compensation events**

- Z9.1 Delete from the last sentence in core clause 61.3 the words, "unless the event arises from the *Supply Manager* giving an instruction, changing an earlier decision or correcting an assumption".

**Z10 Purchaser's limitation of liability**

- Z10.1 The *Purchaser's* liability to the *Supplier* for the *Supplier's* indirect or consequential loss is limited to R0.00 (zero Rand)
- Z10.2 The *Supplier's* entitlement under the indemnity in 83.1 is provided for in 60.1(12) and the *Purchaser's* liability under the indemnity is limited.

**Z11 Termination: Add to core clause 91.1, at the second main bullet point, fourth sub-bullet point, after the words "against it":**

- Z11.1 or had a business rescue order granted against it.

**Z12 Addition to secondary Option X7 Delay damages (if applicable in this contract)**

- Z12.1 If the amount due for the *Supplier's* payment of delay damages reaches the limits stated in this Contract Data for Option X7, the *Purchaser* may terminate the *Supplier's* obligation to Provide the Goods and Services using the same procedures and payment on termination as those applied for reasons R1 to R15 or R18 stated in the Termination Table.

## Annexure A: Supply Requirements

[Notes: The example given in the NEC3 Supply Contract Guidance Notes pages 15 to 20 inclusive is based on Incoterms 2000. However users will probably wish to use Incoterms 2010 which the details below are based on. Users may need to adjust the information to comply with actual requirements. First decide whether Incoterms will be used or not, then delete the arrangement below which does not apply and delete these notes]

### The Supply Requirements for this contract are based on the use of INCOTERMS:

The *Supplier* supplies the *goods* in accordance with INCOTERMS 2010<sup>3</sup> as follows:

[Select the group and then term within the group which applies and state the applicable delivery place. Delete all the other groups and this note]

| Group    | Category             | Term                 | Delivery Place              |
|----------|----------------------|----------------------|-----------------------------|
| E        | departure            | EXW                  |                             |
| F        | main carriage unpaid | FCA, FAS, FOB        |                             |
| C        | main carriage paid   | CFR, CIF, CPT, CIP   |                             |
| <b>D</b> | <b>arrival</b>       | <b>DAT, DAP, DDP</b> | <b>Ex Works Rosherville</b> |

The Parties obligations described in Incoterms for the category and term selected are now incorporated into this contract as part of the Supply Requirements and hence the Goods Information.

The obligations of seller and buyer for the selected Incoterm determine each Party's costs, risks and insurance requirements incidental to the supply and transport of the *goods* from *Supplier* to *Purchaser*.

For each of the thirteen terms, Incoterms set out obligations of the seller (the *Supplier*) in ten paragraphs identified as A1 to A10 and the corresponding obligations of the buyer (the *Purchaser*) in paragraphs B1 to B10. These obligations cover the following subjects:

| A          | The <i>Supplier's</i> obligations                                      | B          | The <i>Purchaser's</i> obligations                                     |
|------------|--|------------|--|
| <b>A1</b>  | Provision of goods in conformity with contract                         | <b>B1</b>  | Payment of the price   |
| <b>A2</b>  | Licences, authorisations and formalities                               | <b>B2</b>  | Licences, authorisations and formalities                               |
| <b>A3</b>  | Contracts of carriage and insurance                                    | <b>B3</b>  | Contracts of carriage and insurance                                    |
| <b>A4</b>  | Delivery   | <b>B4</b>  | Taking delivery  |
| <b>A5</b>  | Transfer of risks  | <b>B5</b>  | Transfer of risks  |
| <b>A6</b>  | Division of costs  | <b>B6</b>  | Division of costs  |
| <b>A7</b>  | Notice to the buyer  | <b>B7</b>  | Notice to the seller   |
| <b>A8</b>  | Proof of delivery, transport document or equivalent electronic message | <b>B8</b>  | Proof of delivery, transport document or equivalent electronic message |
| <b>A9</b>  | Checking - packing - marking   | <b>B9</b>  | Inspection of goods  |
| <b>A10</b> | Other obligations  | <b>B10</b> | Other obligations  |

[Should there be a need to amplify any of the published obligations listed above for the chosen INCOTERM, add them here.]

All other information NOT pertinent to the above is given in the balance of the Goods Information

<sup>3</sup> International Chamber of Commerce, Incoterms 2010, Paris, January 2011

**The Supply Requirements for this contract are as follows:**

[Use these when INCOTERMS do not apply].

|  |  |                            |
|--|--|----------------------------|
| <b>1. The requirements for the supply are</b>        | [State the constraints on how the <i>Supplier</i> manufactures, prototypes, tests and stores the <i>goods</i> including order and timing]                        |                            |
| <b>2. The requirements for transport are</b>         | Ex Works Bearing Services Rosherville  |                            |
| <b>3. The delivery place is</b>                      | Rosherville Workshop or Eskom sites as specified in each Task Order  |                            |
| <b>4. Actions of the Parties during supply</b>       | <b>Action</b>  | <b>Party which does it</b> |
|  | Giving notice of Delivery  | supplier                   |
|  | Checking packing and marking before dispatch   | supplier                   |
|  | Contracting for transport  | supplier                   |
|  | Pay costs of transport   | supplier                   |
|  | Arrange access to delivery place   | Supplier and Buyer         |
|  | Loading the <i>goods</i>   | supplier                   |
|  | Unloading the <i>goods</i>   | supplier                   |
| <b>For international procurement</b>                 | Undertake export requirements  | supplier                   |
|  | Undertake import requirements  | Supplier and Buyer         |
| <b>5. Information to be provided by the Supplier</b> | <b>Title of document</b>   |                            |
|  | Packing lists for cases and their contents   |                            |
|  | Copy of invoice for the <i>goods</i>   |                            |
|  | Delivery Note  |                            |
|  | Test results and maintenance manuals   |                            |
| <b>For international procurement</b>                 | Licences, authorisations and other formalities associated with export of the <i>goods</i>  |                            |
|  | Air Waybill or Bill of Lading with associated landing, delivery and forwarding order   |                            |
|  | The Bill of Entry endorsed by the importation authority  |                            |
|  | Customs work sheets, showing tax, duties and surcharges which the law of the country into which the <i>goods</i> are being imported requires the importer to pay |                            |
|  | Invoice from the importation clearing agent showing airline fees, landing charges, wharfage and dock dues as applicable  |                            |
|  | Specify other import documents required by authorised officials.   |                            |

All other information NOT pertinent to the above is given in the balance of the Goods Information

## Annexure B: Insurance provided by the Purchaser

*These notes are provided as guidance to tendering suppliers and the Supplier about the insurance provided by the Purchaser. These notes are not part of this contract. The Supplier must obtain its own advice.*

### Transit insurance of goods originating from outside the borders of the Republic of South Africa

For the purpose of supply contracts, the only insurance provided by Eskom (the *Purchaser*) is transit shipment cover, commonly known as Marine Insurance for air, sea, rail and road freight (including local land arrangements) for conveyance of *goods* originating outside RSA. Please consult the website stated below to ascertain whether Format A, Format B or Format Dx is applicable to this contract and then the

- Marine Insurance Policy wording;
- Eskom Shipment Policies and Procedures – note a pre-shipment survey form has to be completed under certain circumstances;
- Marine Claims Handling Procedures – for important shipment actions and claims forms in event of damages to cargo freight via sea, barge, air, road or rail.

For EXW (Ex Works collections) this is of no concern to the *Supplier* but for any other Supply Requirement (such as CIF, DDU, or DDP) the *Supplier* need not provide such insurance even if the INCOTERM requires it and tendering suppliers should 'discount' their prices when tendering to allow for this provision by the *Purchaser* (Eskom).

### Supplier's liability for damage to the Purchaser's property

Whilst this is a liability the *Supplier* carries and should cover (if he is required to deliver the *goods* to the *Purchaser's* premises) his liability is limited to the amount of cover provided to the *Purchaser* within his assets policy. This amount varies depending on the Division within Eskom to which the *Supplier* is making the delivery. For any one occurrence or series of occurrences arising out of one event but unlimited during the period of insurance the *Supplier's* liability would be:

- R15million for Generation Division projects,
- R7.5million for Transmission Division projects or
- R1.0million for Distribution Division projects

### All other insurance

As required by clause 84, the *Supplier* provides all other insurance for his risks. The *Supplier* should give further consideration to providing for these additional insurance concepts [for amounts and periods of insurance the *Supplier* deems fit and necessary].

Professional Indemnity: The insurance provided shall indemnify the *Supplier* (and/or his professional consultant) for those sums which the *Supplier* or his consultant shall become legally liable to pay as damages arising from any claim first made against the *Supplier* / consultant and reported to their insurers during the Period of Insurance, directly arising out of any negligent act, error or omission committed or alleged to have been committed by the *Supplier* / consultant in the conduct of **professional services** (for example, design) in connection with this contract.

Products Liability: A special General Liability extension for liability arising out of the *Supplier's* **defective**:

- production and manufacturing process (workmanship or material), or
- product design, or
- warnings, instructions, usage and maintenance manuals and specifications.

For any further explanation of insurance requirements tendering suppliers are advised to consult their brokers or insurers who may in turn contact Eskom Insurance Management Services per contact details provided on the following website:

## C1.2 Contract Data

### Part two - Data provided by the *Supplier*.

**[Instructions to the contract compiler: (delete this note before issue to tenderers with an enquiry)**

Whenever a cell is shaded in the left hand column it denotes this data is optional and would be required in relation to the option selected. In the event that the option is not required select and delete the whole row.]

**Notes to a tendering supplier:**

1. Please read both the NEC3 Supply Contract (SC3)<sup>4</sup> and the relevant parts of its Guidance Notes (SC3-GN)<sup>5</sup> in order to understand the implications of this Data which the tenderer is required to complete.
2. The number of the clause which requires the data is shown in the left hand column for each statement however other clauses may also use the same data
3. Where a form field like this [       ] appears, data is required to be inserted relevant to the option selected. Click on the form field **once** and type in the data. Otherwise complete by hand and in ink.

Completion of the data in full, according to Options chosen, is essential to create a complete contract.

| Clause   | Statement  | Data   |
|----------|--|--|
| 10.1     | The <i>Supplier</i> is (Name):<br><br>Address<br><br>Tel No.<br><br>Fax No.                                  |  |
| 11.2(8)  | The Goods Information for the <i>Supplier's</i> design is in:  | <b>To be specified in Annexure A of this document</b>                          |
| 11.2(11) | The tendered total of the Prices is  | <b>R       ,<br/>(in words)</b>  |
| 11.2(12) | The <i>price schedule</i> is in:   |  |
| 11.2(14) | The following matters will be included in the Risk Register  | <b>Not applicable</b>  |
| 25.2     | The restrictions to access for the <i>Supply Manager</i> and Others to work being done for this contract are | <b>Not applicable</b>  |
| 30.1     | The <i>delivery date</i> of the <i>goods</i> and <i>services</i> is:   | <b>To be included in the additional data section of each Task Order issued</b> |
| 31.1     | The programme identified in the Contract Data is contained in:   | <b>To be included in the additional data section of each Task Order issued</b> |

<sup>4</sup> Either April 2013 or December 2009 Edition as stated by *Purchaser* in Contract Data part 1.

<sup>5</sup> Available from Engineering Contract Strategies Tel 011 803 3008, Fax 086 539 1902, or [www.ecs.co.za](http://www.ecs.co.za)

63.2

The *percentage for overheads and profit* added to the Defined Cost is

**Deemed to be included in the Pricing data provided by the supplier**

## PART 2: PRICING DATA

### NEC3 Supply Contract

| Document reference | Title                     | No of pages |
|--------------------|---------------------------|-------------|
| C2.1               | Pricing assumptions       | 2           |
| C2.2               | The <i>price schedule</i> | [•]         |

# C2.1 Pricing assumptions

## How goods and services are priced and assessed for payment

Clause 11 in NEC3 Supply Contract, (SC3) core clauses states:

|                                     |            |  |
|-------------------------------------|------------|--|
| <b>Identified and defined terms</b> | 11<br>11.2 | <p>(11) The Prices are the amounts stated in the price column of the Price Schedule. Where a quantity is stated for an item in the Price Schedule, the Price is calculated by multiplying the quantity by the rate.</p> <p>(12) The Price Schedule is the <i>price schedule</i> unless later changed in accordance with this contract.</p>   |
| <b>Assessing the amount due</b>     | 50.2       | <p>The amount due is</p> <ul style="list-style-type: none"> <li>• the Price for each lump sum item in the Price Schedule which the <i>Supplier</i> has completed,</li> <li>• where a quantity is stated for an item in the Price Schedule, an amount calculated by multiplying the quantity which the <i>Supplier</i> has completed by the rate,</li> <li>• plus other amounts to be paid to the <i>Supplier</i>,</li> <li>• less amounts to be paid by or retained from the <i>Supplier</i>.</li> </ul> <p>Any tax which the law requires the <i>Purchaser</i> to pay to the <i>Supplier</i> is included in the amount due.</p> |

This confirms that the Supply Contract is a priced contract where the Prices are derived from a list of items of *goods* and *services* which can be priced as lump sums or as expected quantities of *goods* and *services* multiplied by a rate, or a mix of both.

## Function of the Price Schedule

Clause 53.1 states: “Information in the Price Schedule is not Goods Information”. This confirms that instructions to do work or how it is to be done are not included in the Price Schedule but in the Goods Information. This is further confirmed by Clause 20.1 which states, “The *Supplier* Provides the Goods and Services in accordance with the Goods Information”. Hence the *Supplier* does **not** Provide the Goods and Services in accordance with the Price Schedule. The Price Schedule is only a pricing document.

## Preparing the *price schedule*

Items in the *price schedule* may have been inserted by the *Purchaser* and the tendering supplier should insert any additional items which he considers necessary. Whichever party provides the items in the *price schedule* the total of the Prices is assumed to be fully inclusive of everything necessary to Provide the Goods and Services as described at the time of entering into this contract.

It will be assumed that the tendering supplier has

- Read Pages 8, 11, 12 and Appendix 5 of the SC3 Guidance Notes before preparing the *price schedule*;
- Included in his Prices and rates for correction of Defects (core clause 43.1) as there is no compensation event for this unless the Defect is due to a *Supplier's* risk;
- Spread the cost of doing work he chooses not to list as separate items in the *price schedule*

across other Prices and rates in order to fulfil the obligation to Provide the Goods and Services for the tendered total of the Prices;

- Understood that there is no adjustment to lump sum prices in the *price schedule* if the amount, or quantity, of work within that lump sum item later turns out to be different to that which the *Supplier* estimated at time of tender. The only basis for a change to the Prices is as a result of a compensation event per clause 60.1;
- Understood that the *Supplier* does not have to allow in his Prices and rates for matters that may arise as a result of a compensation event.

### **Format of the *price schedule***

Entries in the first four columns in the *price schedule* in section C2.2 are made either by the *Purchaser* or the tendering supplier.

If the *Supplier* is to be paid an amount for the item which is not adjusted if the quantity of work in the item changes, the tendering supplier enters the amount in the Price column only, the Unit, Quantity and Rate columns being left blank.

If the *Supplier* is to be paid an amount for the item which is the rate for the item multiplied by the quantity completed, the tendering *Supplier* enters the rate which is then multiplied by the Quantity to produce the Price, which is also entered.

If the *Supplier* is to be paid an amount for an item proportional to the length of time for which the *goods* and *services* are provided, a unit of time is stated in the Unit column and the length of time (as a quantity of the stated units of time) is stated in the Quantity column.



## PART 3: SCOPE OF WORK

| Document reference | Title                                | No of pages |
|--------------------|--------------------------------------|-------------|
|                    | This cover page                      | 1           |
| C3.1               | <i>Purchaser's Goods Information</i> |             |
| C3.2               | <i>Supplier's Goods Information</i>  |             |
|                    | Total number of pages                |             |

## C3.1: PURCHASER’S GOODS INFORMATION

### Contents

When the document is complete, insert a 'Table of Contents'. To do this go to: Reference, → Table of Contents. Three levels and the title (but not the subtitle) may be shown if the formats used in this template are retained. Alternatively just update the table below when the drafting of the Goods Information is complete by clicking on 'References' then 'Update Table' then 'Update entire table'

|   |                              |
|---|------------------------------|
| <b>Part 3: Scope of Work</b> .....  | <b>24</b>                    |
| <b>C3.1: Purchaser’s Goods Information</b> .....                              | <b>1</b>                     |
| <b>1 Overview and purpose of the goods and services</b> .....                 | <b>3</b>                     |
| <b>2 Specification and description of the goods</b> .....                     | Error! Bookmark not defined. |
| 2.1 Purchaser’s design .....  | 33                           |
| 2.2 Procedure for submission and acceptance of Supplier’s design .....        | 33                           |
| 2.3 Other requirements of the Supplier’s design .....                         | 33                           |
| 2.4 Use of Supplier’s design .....  | 34                           |
| 2.5 Manufacture & fabrication .....   | 34                           |
| 2.6 Factory acceptance testing (FAT) .....                                    | 34                           |
| 2.7 Other tests and inspections and commissioning in place of use .....       | 34                           |
| 2.8 Operating manuals and maintenance schedules .....                         | 34                           |
| <b>3 Supply Requirements</b> .....  | <b>34</b>                    |
| <b>4 Specification of the services to be provided</b> .....                   | <b>35</b>                    |
| <b>5 Constraints on how the Supplier Provides the Goods</b> .....             | <b>35</b>                    |
| 5.1 Programming constraints .....   | 35                           |
| 5.2 Work to be done by the Delivery Date .....                                | 35                           |
| 5.3 Marking the goods .....   | 35                           |
| 5.4 Constraints at the delivery place and place of use .....                  | 35                           |
| 5.5 Cooperating with Others .....   | 35                           |
| 5.6 Services & other things to be provided by the Purchaser or Supplier ..... | 36                           |
| 5.7 Management meetings .....   | 36                           |
| 5.8 Documentation control .....   | 36                           |
| 5.9 Health and safety risk management .....                                   | 37                           |
| 5.10 Environmental constraints and management .....                           | 37                           |
| 5.11 Quality .....  | 37                           |
| 5.12 Invoicing and payment .....  | 37                           |
| 5.13 Insurance provided by the Purchaser .....                                | 37                           |
| 5.14 Contract change management .....   | 38                           |
| 5.15 Provision of bonds and guarantees .....                                  | 38                           |

5.16 Records of Defined Cost, payments & assessments of compensation events to be kept by the *Supplier* 38

|             |  |           |
|-------------|--|-----------|
| <b>6</b>    | <b><u>Procurement</u></b> .....                        | <b>38</b> |
| 6.1         | <u>Subcontracting</u> .....                            | 38        |
| 6.1.1       | <u>Preferred subcontractors</u> .....                  | 38        |
| 6.1.2       | <u>Limitations on subcontracting</u> .....             | 38        |
| 6.1.3       | <u>Spares and consumables</u> .....                    | 38        |
| 6.1.4       | <u>Other requirements related to procurement</u> ..... | 39        |
| <b>7</b>    | <b><u>List of drawings</u></b> .....                   | <b>39</b> |
| 7.1         | <u>Drawings issued by the <i>Purchaser</i></u> .....   | 39        |
| <b>C3.2</b> | <b><u>Supplier's Goods Information</u></b> .....       | <b>40</b> |

# 1 Overview and purpose of the goods and services

## SCOPE OF WORK

### THE SUPPLY AND MANUFACTURE OF COUPLING, JIG PLATES AND ACCESSORIES

1. Subcontractor to supply material and manufacture the jig plate assemblies as per specification on the drawings, and the list of all the jig plates required.
2. Manufacturing drawings will be supplied to a subcontractor (current available drawings are attached, other drawing will follow as they become available).
3. Subcontractor to also supply all items as per assembly drawings.

#### Kendal Power Station – Gen/Exciter Jig Plate Assembly

Jig plate need to be manufactured with its accessories as tabled below (also see attached relevant drawings): Therefore we need to manufacture eight (8) items as shown below (13.64\_200, 13.64\_201, 13.64\_202, 13.64\_218) and (13.64\_204, 13.64\_205, 13.64\_206, 13.64\_207).  
 Quotation needs to also include **Bought Out Item** as tabulated on the drawings attached.

| DRAWING NUMBER | DESCRIPTION                                    |
|----------------|--|
| 13.64_216      | Gen-Exciter Coupling with Sleeve MAIN ASSEMBLY |

|           |                                |
|-----------|--------------------------------|
| 13.64_217 | Gen-Exciter Jig Plate ASSEMBLY |
| 13.64_218 | Gen-Exciter Jig Plate PART     |
| 13.64_202 | Coupling Bush PART             |
| 13.64_201 | Jacking Bracket PART           |
| 13.64_200 | Spigot Ring PART               |

|           |  |
|-----------|--|
| 13.64_203 | Gen-Exciter Expanding Coupling Collar ASSEMBLY |
| 13.64_204 | Expanding Collar PART                          |
| 13.64_205 | Expanding Drive PART                           |
| 13.64_206 | Expanding Shoe PART                            |
| 13.64_207 | Nylon Support Bush PART                        |

**Bought Out Items:**

- Socket Head Cap Screw M12 x 60 (ISO 4762) (Class 8.8)
- Socket Head Cap Screw M16 x 120 (ISO 4762) (Class 8.8)
- Socket Head Cap Screw M10 x 30 (ISO 4762) (Class 8.8)
- Garter Spring DIN 17224 (Di 24 & Du 3.5)
- Dia16 External Circlip (DIN. 471)

**Arnot – LP/Gen Jig Plate MAIN ASSEMBLY**

Jig plate need to be manufactured with its accessories as tabled below (also see attached relevant drawings):

Therefore we need to manufacture items as shown below (13.41\_1790, 13.41\_1791, 13.41\_1792, 13.41\_1793) and (13.641\_1788, 13.41\_1794, 13.41\_1796, 13.41\_1795).

Quotation needs to also include **Bought Out Item** as tabulated on the drawings attached.

| DRAWING NUMBER | DESCRIPTION                            |
|----------------|--|
| 13.41_1786     | Arnot – LP/Gen Jig Plate MAIN ASSEMBLY |

|            |   |
|------------|---|
| 13.41_1789 | Arnot - LP/Gen Expanding Coupling Collar ASSEMBLY |
| 13.41_1790 | Expanding Collar PART                             |
| 13.41_1791 | Expanding Drive Screw PART                        |
| 13.41_1792 | Expanding Shoe PART                               |
| 13.41_1793 | Nylon Support Bush                                |

|            |                           |
|------------|---------------------------|
| 13.41_1787 | LP/Gen Jig Plate ASSEMBLY |
| 13.41_1788 | LP/Gen Jig Plate PART     |
| 13.41_1794 | LP/Gen Jacking Block PART |
| 13.41_1796 | LP/Gen Spigot Ring PART   |
| 13.41_1795 | LP/Gen Jig Bush PART      |

**Bought Out Items:**

- Socket Head Cap Screw M16 x 80 (ISO 4762) (Class 8.8)
- Socket Head Cap Screw M10 x 30 (ISO 4762) (Class 8.8)
- Socket Head Cap Screw M10 x 30 (ISO 4762) (Class 8.8)
- Garter Spring DIN 17224 (Di 26 & Du 3.5)

- Dia. 22 External Circlip (DIN. 471)

**Arnot – IP/LP Jig Plate MAIN ASSEMBLY**

Please note that a jig plate need to be manufactured with its accessories as tabled below (also see attached relevant drawings):

Therefore we need to manufacture items as shown below (13.41\_1790, 13.41\_1791, 13.41\_1792, 13.41\_1793) and (13.641\_1787, 13.41\_1788, 13.41\_1794, 13.41\_1795).

Quotation needs to also include **Bought Out Item** as tabulated on the drawings attached.

| DRAWING NUMBER | DESCRIPTION                           |
|----------------|---------------------------------------|
| 13.41_1786     | Arnot – IP/LP Jig Plate MAIN ASSEMBLY |

|            |   |
|------------|---|
| 13.41_1789 | Arnot - LP/Gen Expanding Coupling Collar ASSEMBLY |
| 13.41_1790 | Expanding Collar PART                             |
| 13.41_1791 | Expanding Drive Screw PART                        |
| 13.41_1792 | Expanding Shoe PART                               |
| 13.41_1793 | Nylon Support Bush                                |

|            |                                  |
|------------|----------------------------------|
| 13.41_1787 | Arnot – IP/LP Jig Plate Assembly |
| 13.41_1788 | Jig Plate PART                   |
| 13.41_1794 | Jacking Block                    |
| 13.41_1795 | Jig Bush                         |

**Arnot HP/IP Jig MAIN ASSEMBLY**

Please note that a jig plate need to be manufactured with its accessories as tabled below (also see attached relevant drawings):

Therefore we need to manufacture items as shown below (13.41\_1799, 13.41\_1800, 13.41\_1794, 13.41\_1795) and (13.41\_1802, 13.41\_1803, 13.41\_1804, 13.41\_1805).

Quotation needs to also include **Bought Out Item** as tabulated on the drawings attached.

| DRAWING NUMBER | DESCRIPTION                   |
|----------------|-------------------------------|
| 13.41_1797     | Arnot HP/IP Jig MAIN ASSEMBLY |

|            |                                |
|------------|--------------------------------|
| 13.41_1798 | Arnot HP/IP Jig Plate Assembly |
| 13.41_1799 | HP/IP Jig Plate                |
| 13.41_1800 | Spigot Ring                    |
| 13.41_1794 | Jacking Block                  |
| 13.41_1795 | Jig Bush                       |

|            |  |
|------------|--|
| 13.41_1801 | Arnot HP/IP Expanding Coupling Collar Assembly |
| 13.41_1802 | Expanding Collar                               |
| 13.41_1803 | Expanding Drive                                |
| 13.41_1804 | Expanding Shoe                                 |
| 13.41_1805 | Nylon Support Bush                             |

**Bought Out Items:**

- Socket Head Cap Screw M16 x 100 (ISO 4762) (Class 8.8)
- Socket Head Cap Screw M10 x 30 (ISO 4762) (Class 8.8)
- Socket Head Cap Screw M12 x 60 (ISO 4762) (Class 8.8)
- Garter Spring DIN 17224 (Di 24 & Du 3.5)
- Dia. 16 External Circlip (DIN. 471)

List of plates required are as per below slide (Jig Plate Availability = 0, means there is jig plate that needs to be manufactured)

| <h2 style="margin: 0;">JIG Plate Overview</h2> |                      |               |                        |                         |
|--|----------------------|---------------|------------------------|-------------------------|
| Fleet  | Stations             | Coupling Type | JIG Plate Availability | Additional Requirements |
| GEC  | Duvha, Tutuka Majuba | HP/IP         | 1                      | 1                       |
|  |                      | IP/LP1        | 1                      | 1                       |
|  |                      | LP1/LP2       | 1                      | 1                       |
|  |                      | LP2/Gen       | 1                      | 1                       |
|  |                      | Gen/Exciter   | 1                      | 1                       |
|  |                      | Exciter/PMG   | 0                      | 2                       |
|  | Camden               | HP/LP         | 0                      | 1                       |
|  |                      | LP/Gen        | 0                      | 1                       |
|  | Grootvlei            | HP/LP         | 0                      | 1                       |
|  |                      | LP/Gen        | 0                      | 1                       |
| ABB/BBC  | Arnot                | HP/IP         | 0                      | 1                       |
|  |                      | IP/LP         | 0                      | 1                       |
|  |                      | LP/Gen        | 0                      | 1                       |
|  | Kriel                | HP/IP         | 0                      | 1                       |
|  |                      | IP/LP1        | 0                      | 1                       |
|  |                      | LP2/Gen       | 1                      | 1                       |
| Siemens  | Kendal               | HP/IP         | 0                      | 1                       |
|  |                      | IP/LP1        | 0                      | 1                       |
|  |                      | LP1/LP2       | 0                      | 1                       |
|  |                      | LP2/Gen       | 0                      | 1                       |
|  |                      | Gen/Exciter   | 0                      | 1                       |
| ABB/BBC  | Medupi               | HP/IP         | 0                      | 1                       |
|  |                      | IP/LP1        | 0                      | 1                       |
|  |                      | LP1/LP2       | 0                      | 1                       |
|  |                      | LP2/Gen       | 0                      | 1                       |
|  | Kusile               | IP/LP1        | 0                      | 1                       |
|  |                      | LP2/Gen       | 0                      | 1                       |

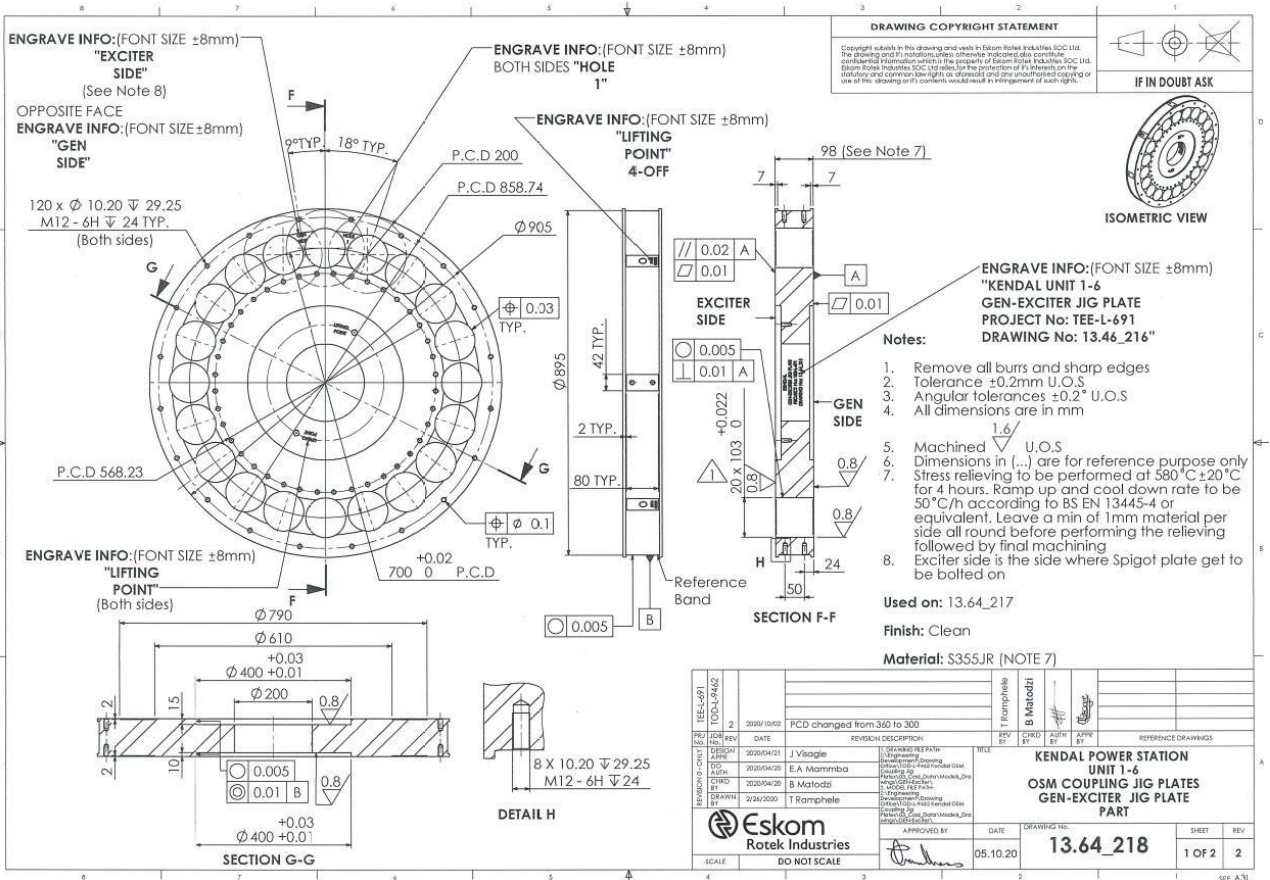
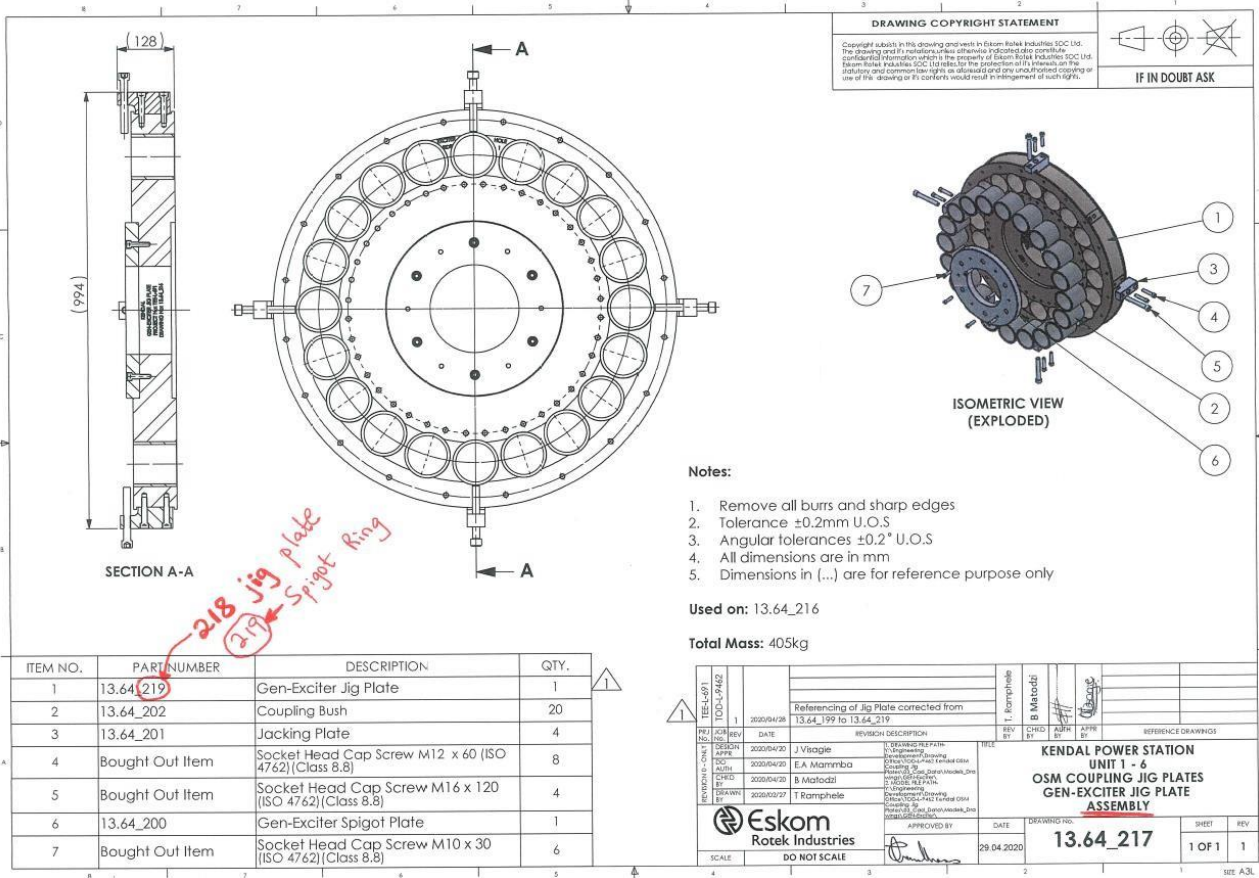

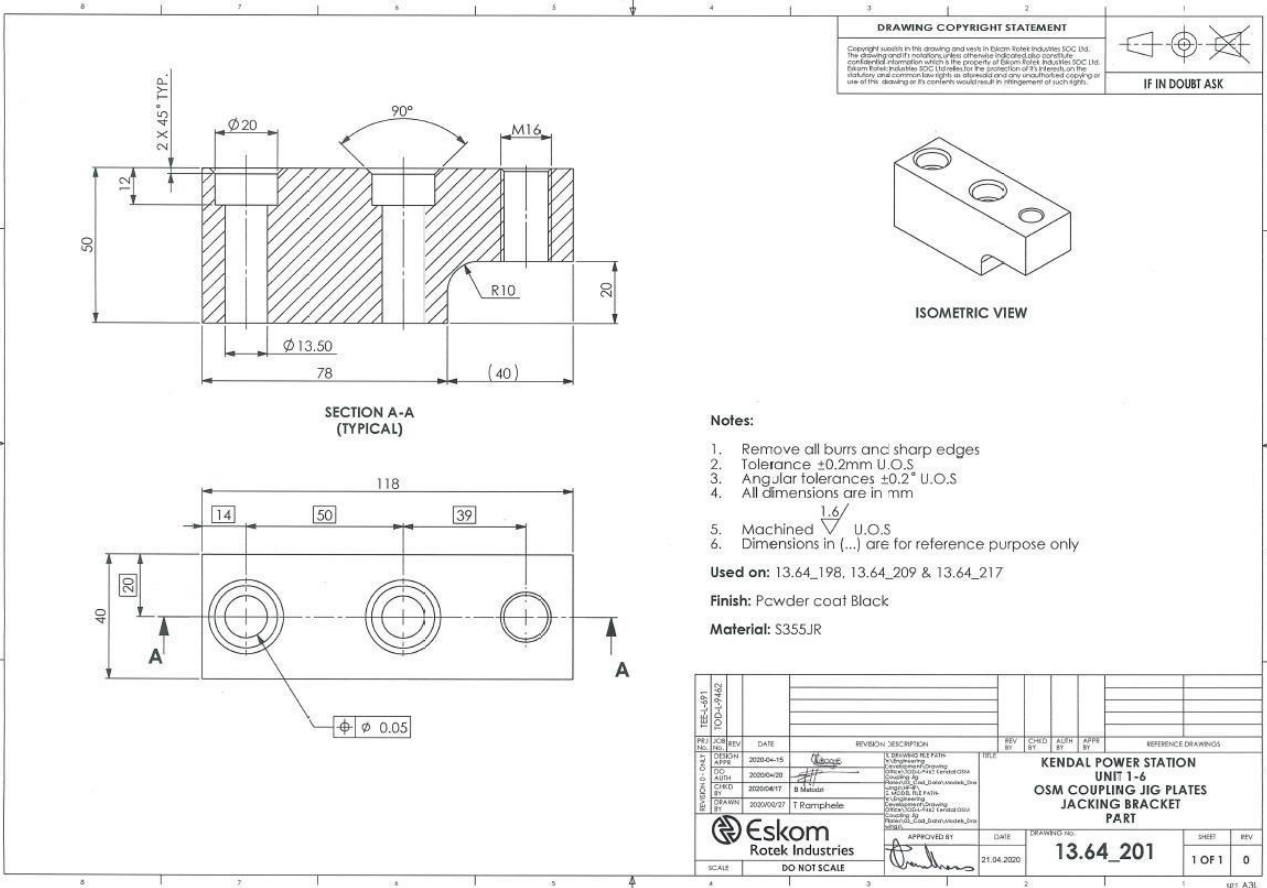
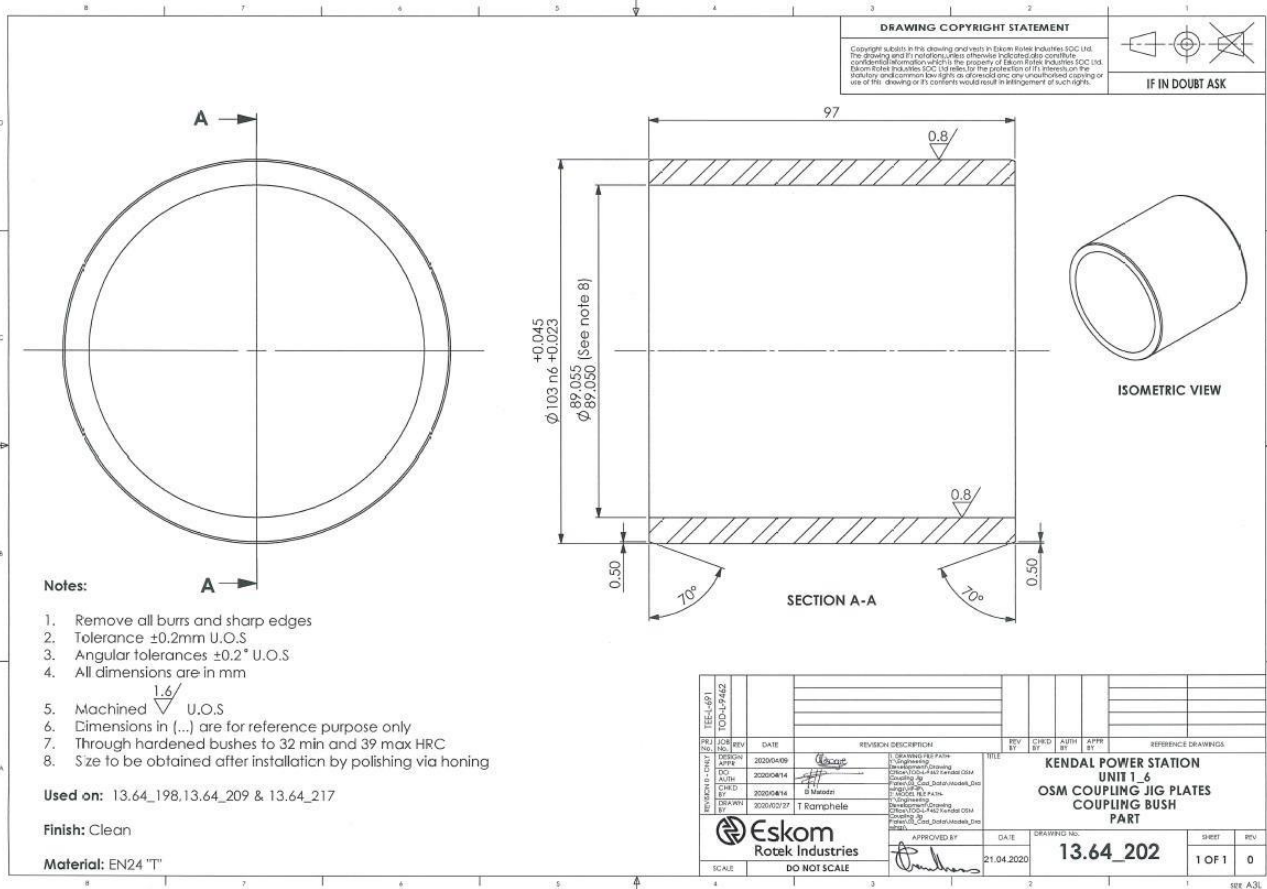

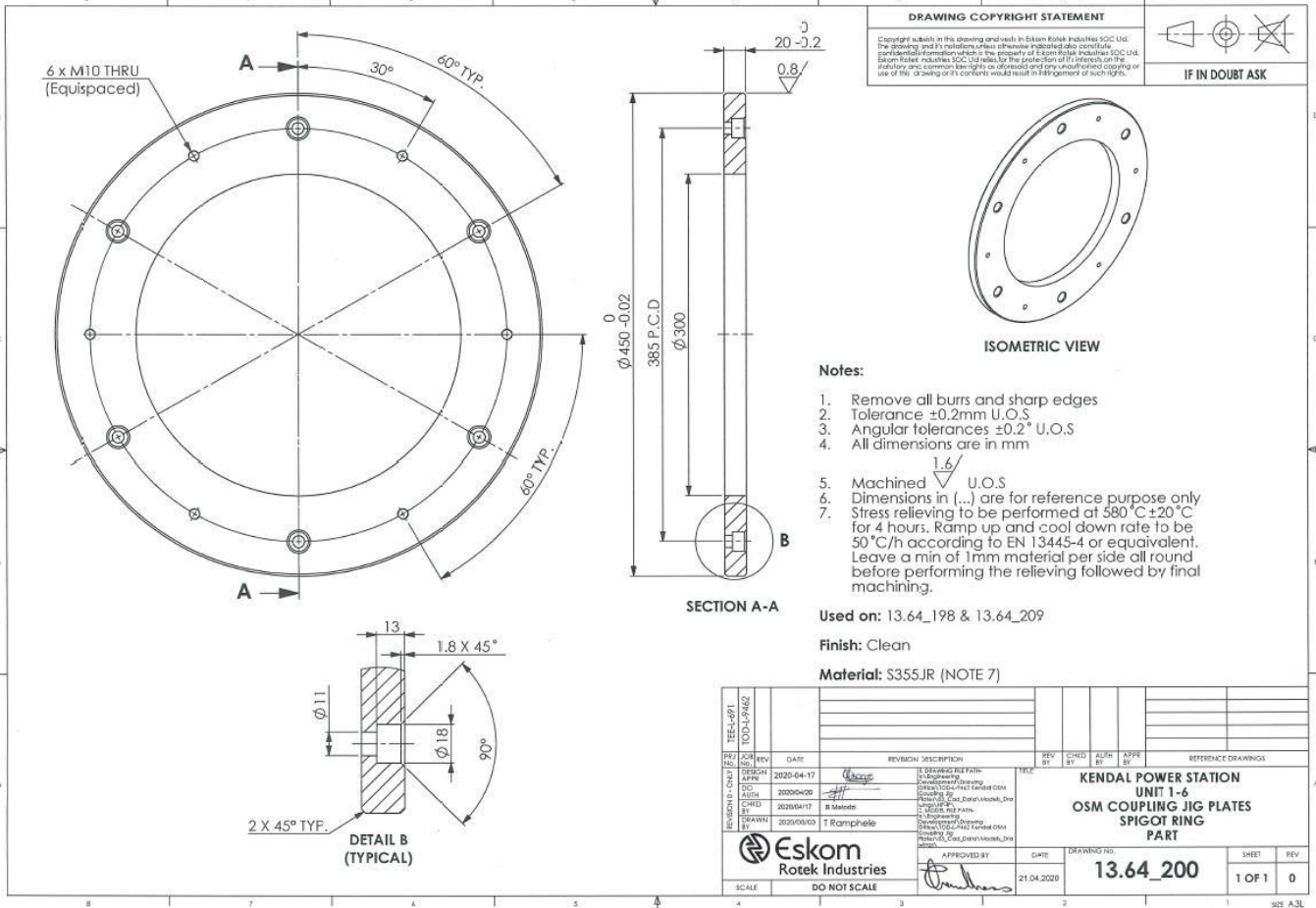

**DRAWING COPYRIGHT STATEMENT**  
 Copyright subsists in this drawing and will, in Eskom Rotek Industries SOC Ltd. The drawing and its contents are the property of Eskom Rotek Industries SOC Ltd. Eskom Rotek Industries SOC Ltd. retains the protection of its interests in the drawing and common law rights in drawings and any unauthorised copying or use of the drawing or its contents would result in infringement of such rights.

**IF IN DOUBT ASK**

- Notes:**
1. Remove all burrs and sharp edges
  2. Tolerance  $\pm 0.2\text{mm U.O.S}$
  3. Angular tolerances  $\pm 0.2^\circ \text{U.O.S}$
  4. All dimensions are in mm
  5. Machined  $\sqrt{1.6}$  U.O.S
  6. Dimensions in (...) are for reference purpose only
  7. Stress relieving to be performed at  $580^\circ\text{C} \pm 20^\circ\text{C}$  for 4 hours. Ramp up and cool down rate to be  $50^\circ\text{C/h}$  according to EN 13445-4 or equivalent. Leave a min of 1mm material per side all round before performing the relieving followed by final machining.

Used on: 13.64\_198 & 13.64\_209  
 Finish: Clean  
 Material: S355JR (NOTE 7)

| REV   | DATE       | REVISION DESCRIPTION                             | REV BY     | CHEK BY     | APPR BY | REFERENCE DRAWINGS  |
|-------|------------|--|------------|-------------|---------|---|
| 1     | 2020-04-17 | ISSUING RELEASE - Engineering Development/Design |            |             |         | <b>KENDAL POWER STATION<br/>           UNIT 1-6<br/>           OSM COUPLING JIG PLATES<br/>           SPIGOT RING<br/>           PART</b> |
| 2     | 2020-04-20 | ISSUING RELEASE - Engineering Development/Design |            |             |         |   |
| 3     | 2020-04-20 | ISSUING RELEASE - Engineering Development/Design |            |             |         |   |
| 4     | 2020-04-20 | ISSUING RELEASE - Engineering Development/Design |            |             |         |   |
|       |            | APPROVED BY                                      | DATE       | DRAWING NO. | SHEET   | REV.  |
| SCALE |            | DO NOT SCALE                                     | 21.04.2020 | 13.64_200   | 1 OF 1  | 0   |

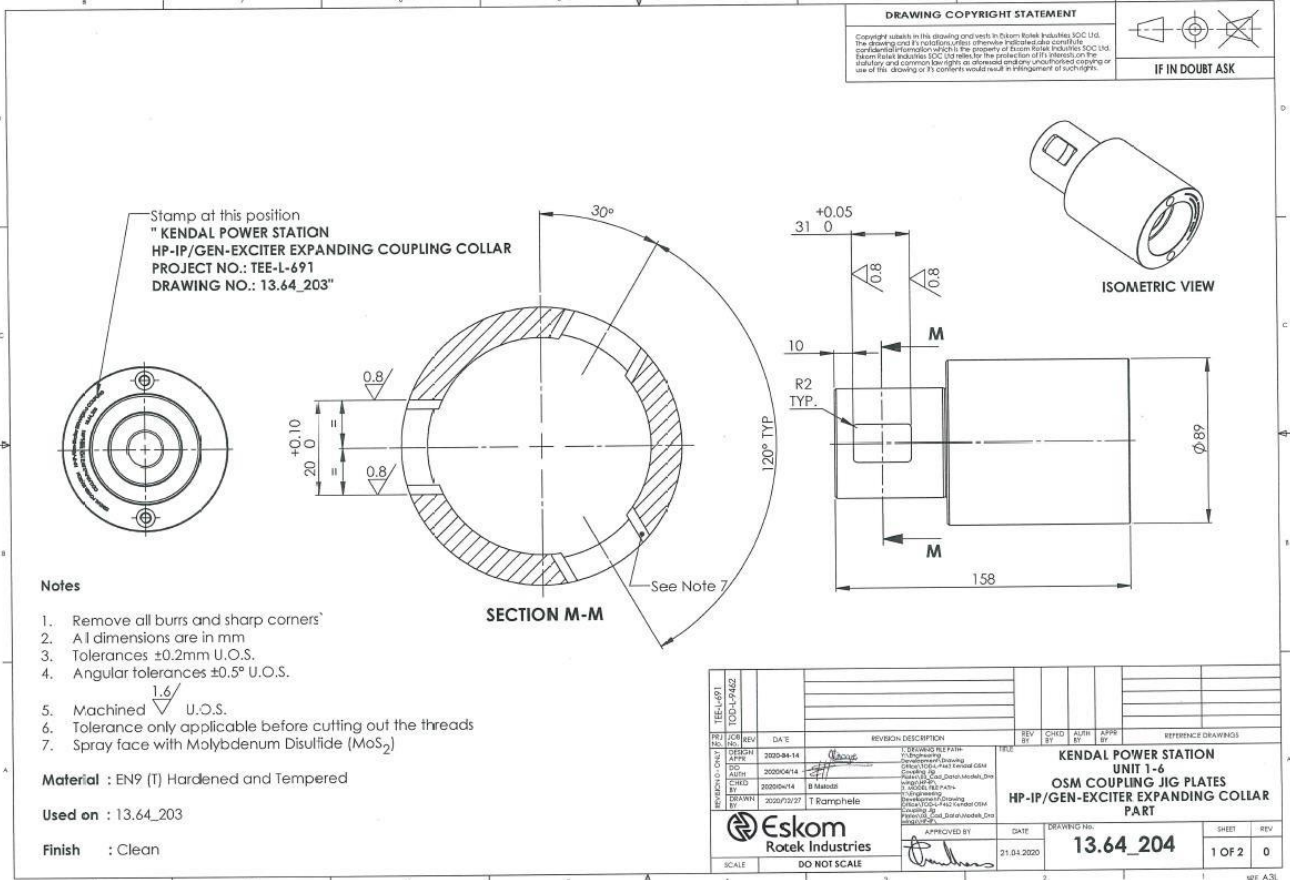
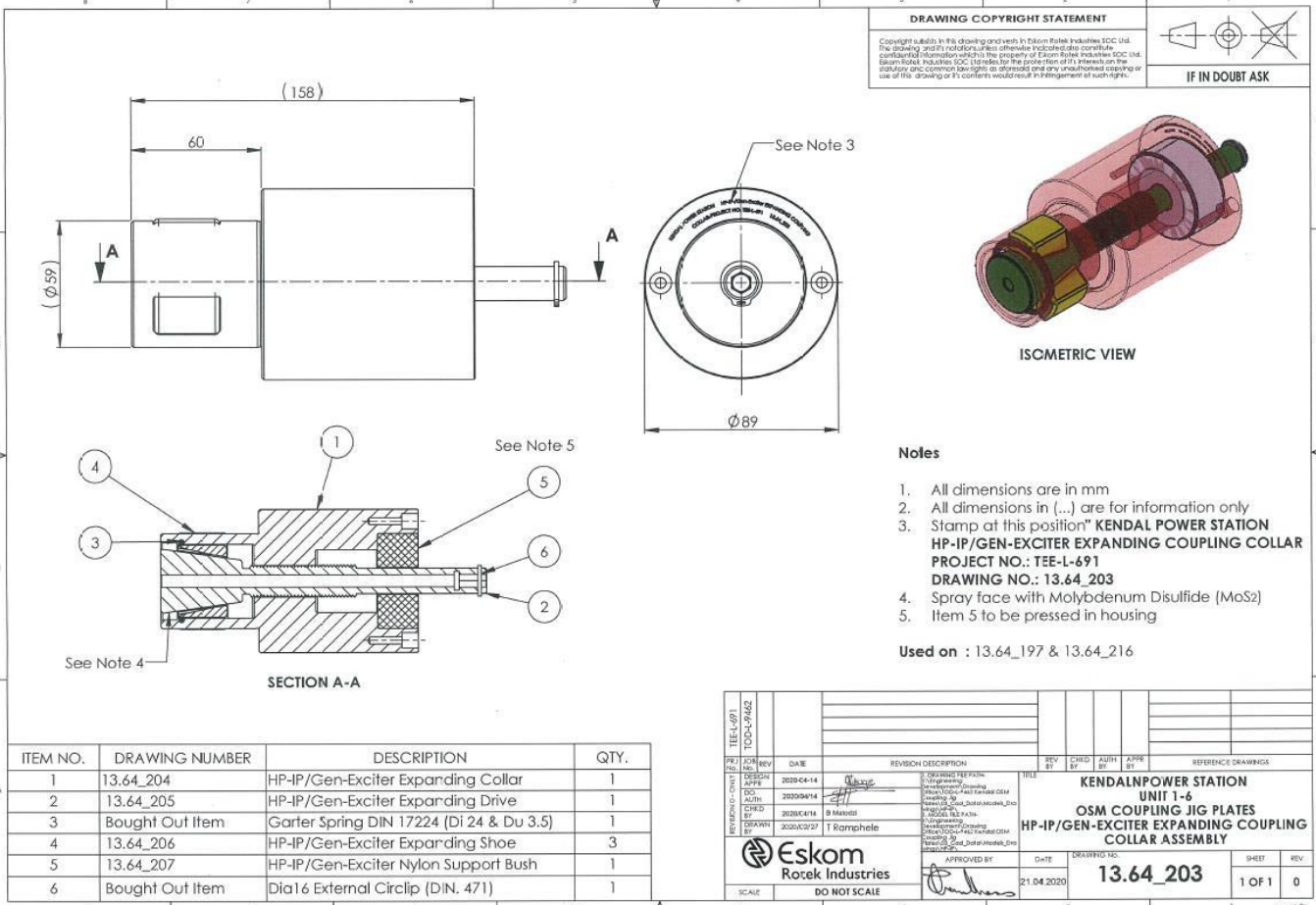

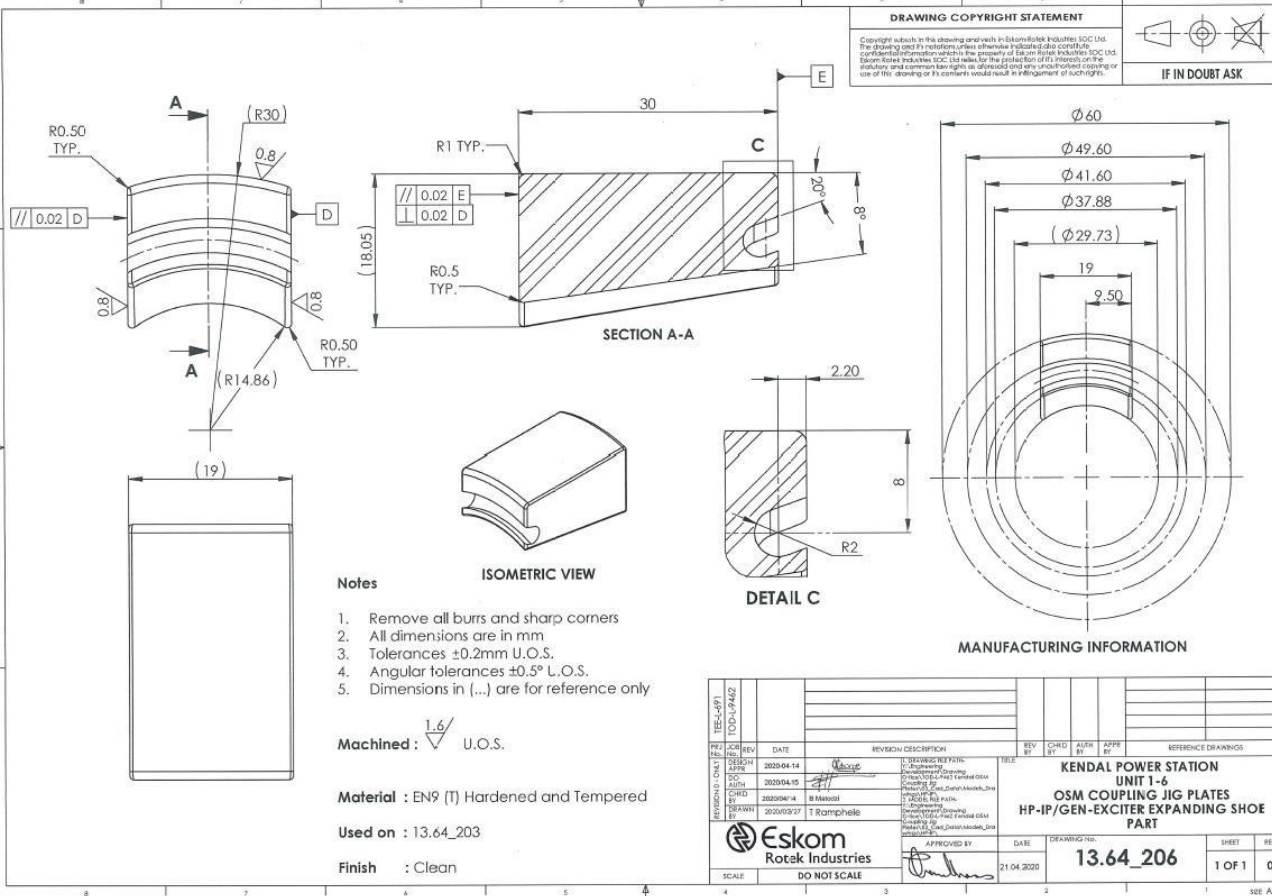
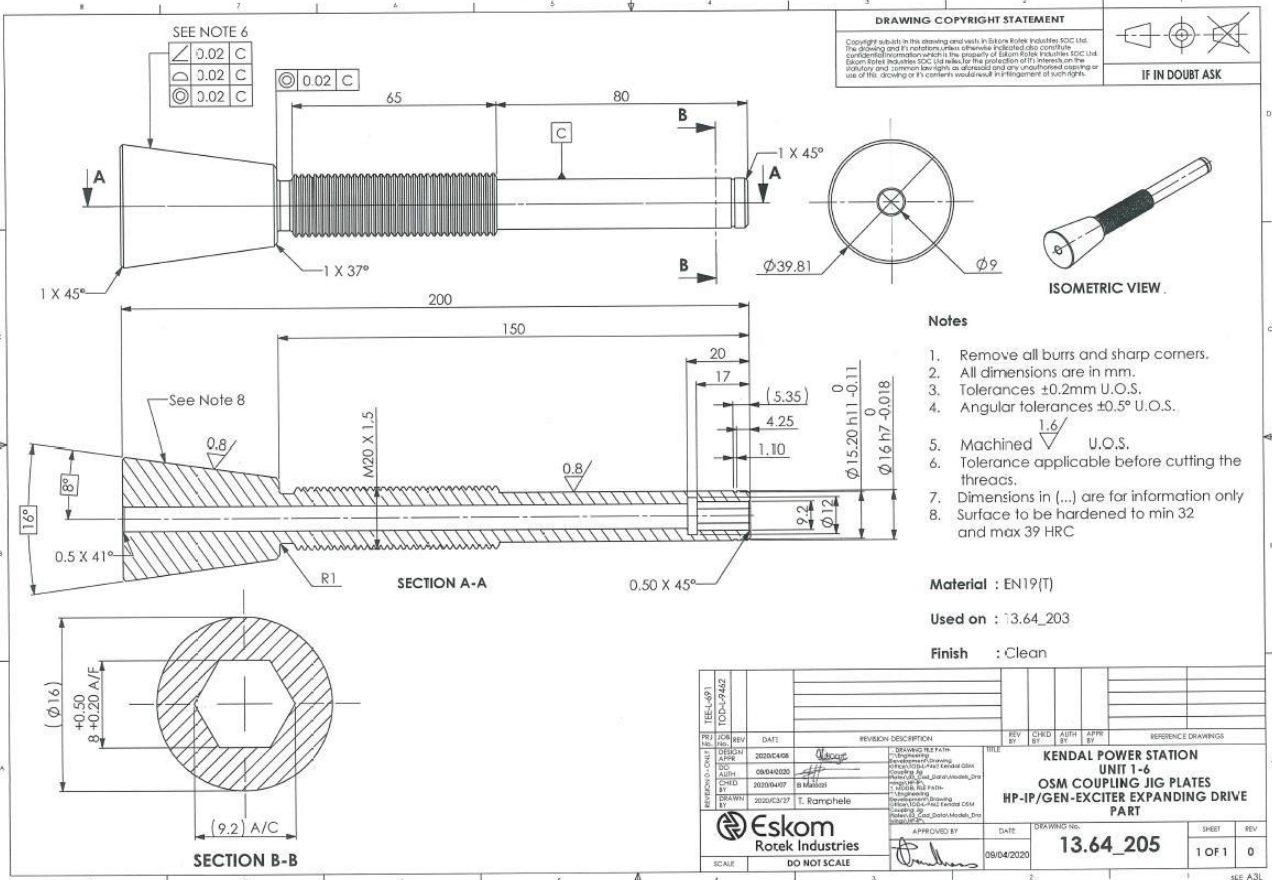

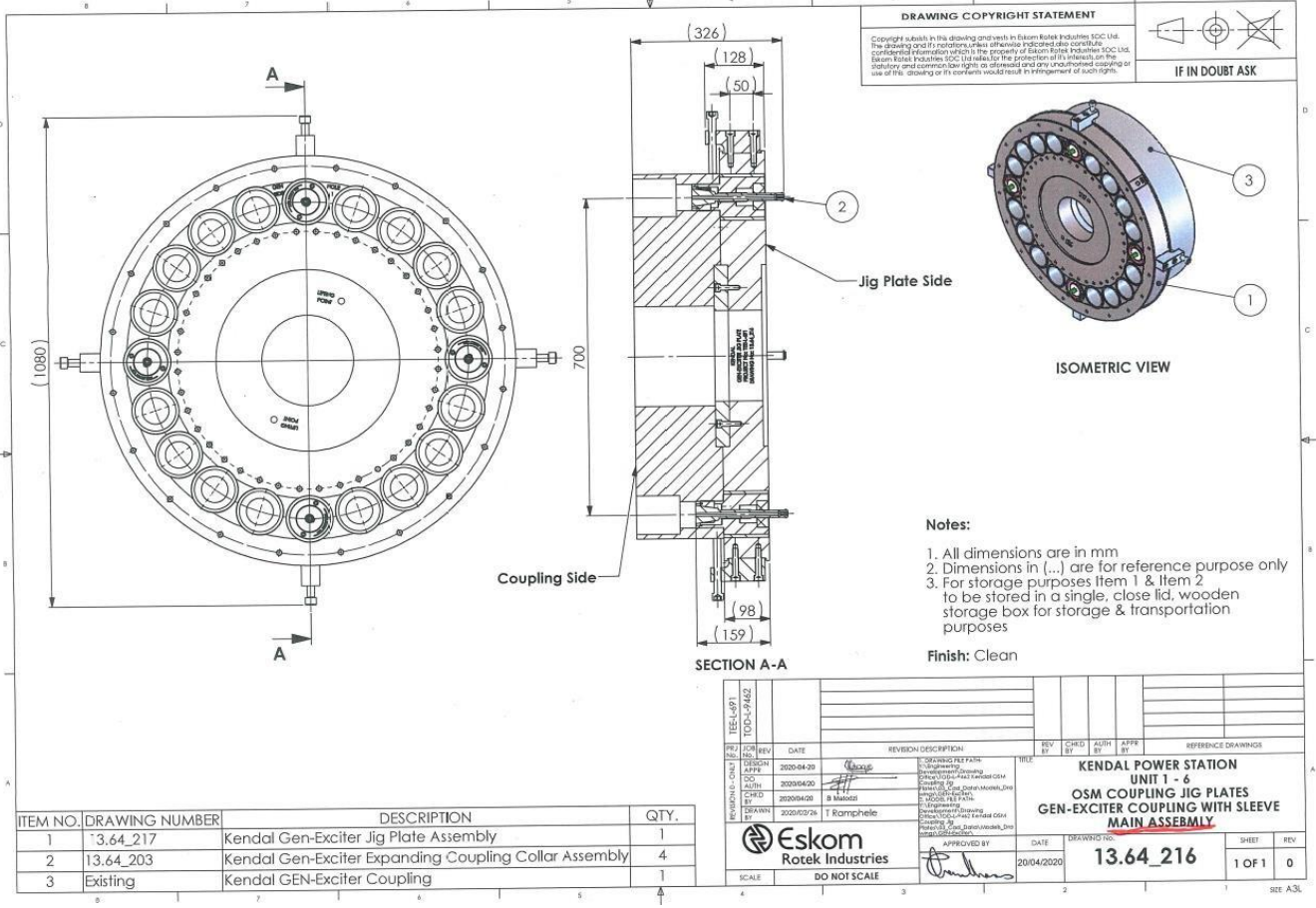
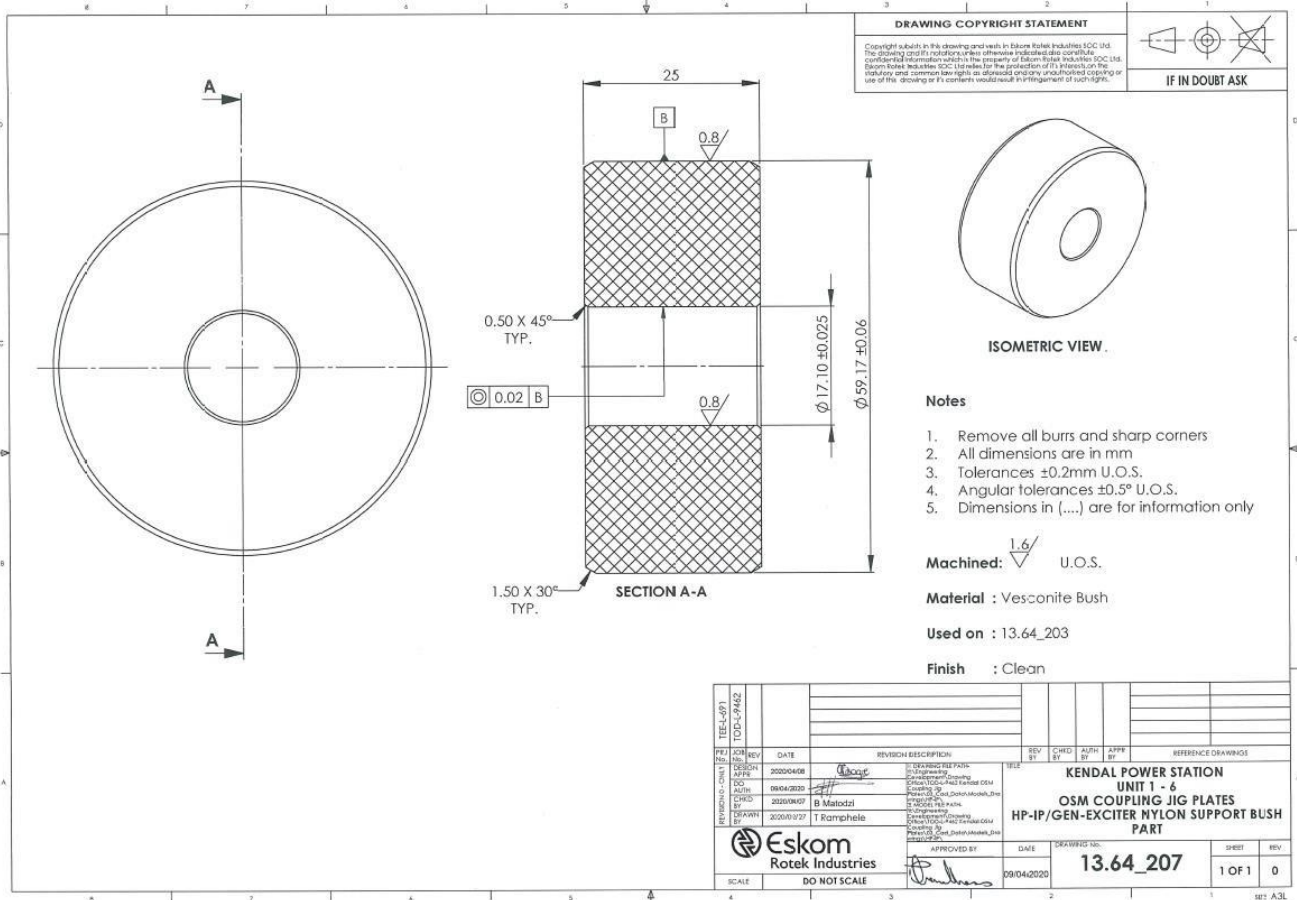

| ITEM NO. | DRAWING NUMBER | DESCRIPTION   | QTY. |
|----------|----------------|---|------|
| 1        | 13.64_217      | Kendal Gen-Exciter Jig Plate Assembly                 | 1    |
| 2        | 13.64_203      | Kendal Gen-Exciter Expanding Coupling Collar Assembly | 4    |
| 3        | Existing       | Kendal GEN-Exciter Coupling                           | 1    |

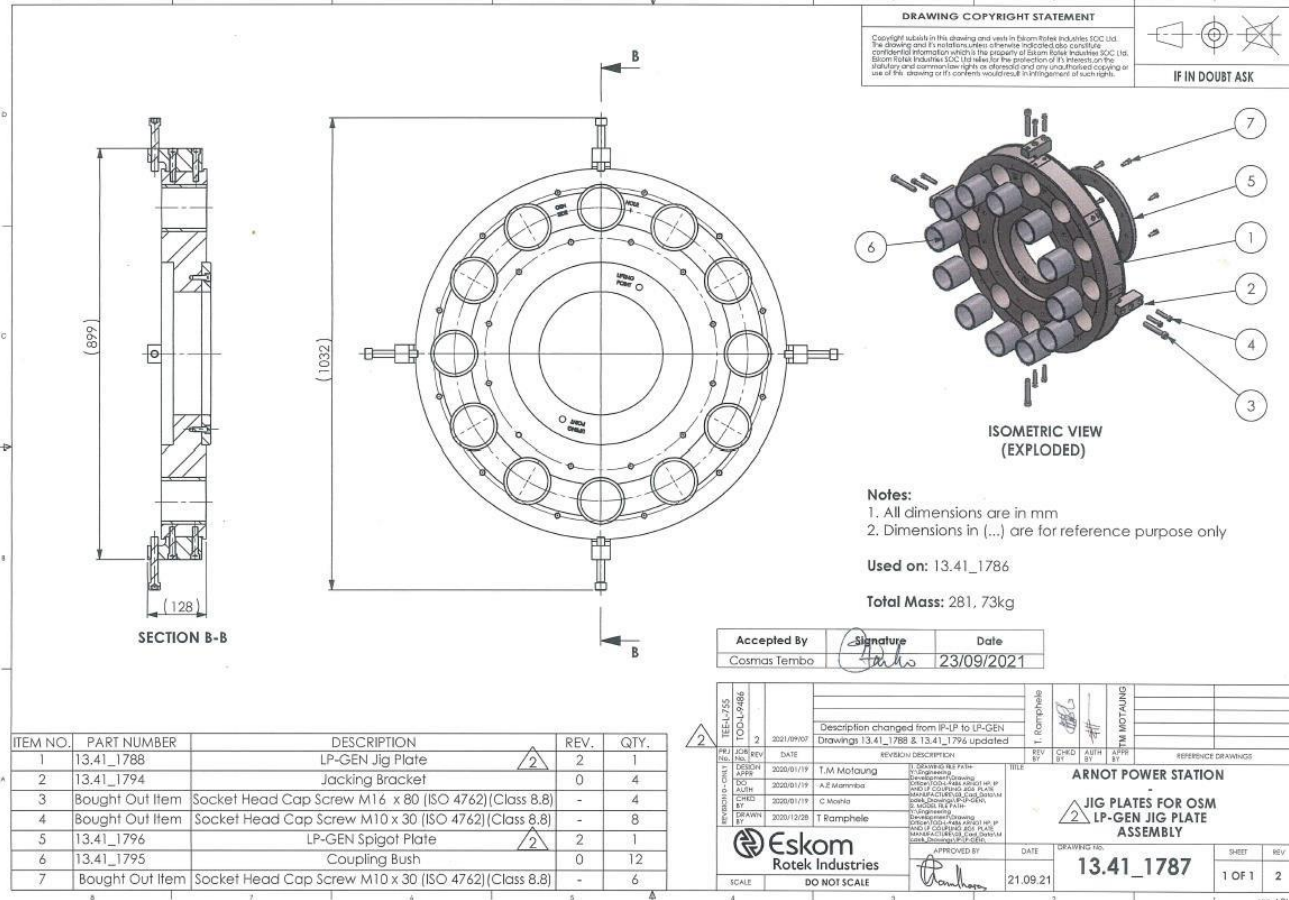
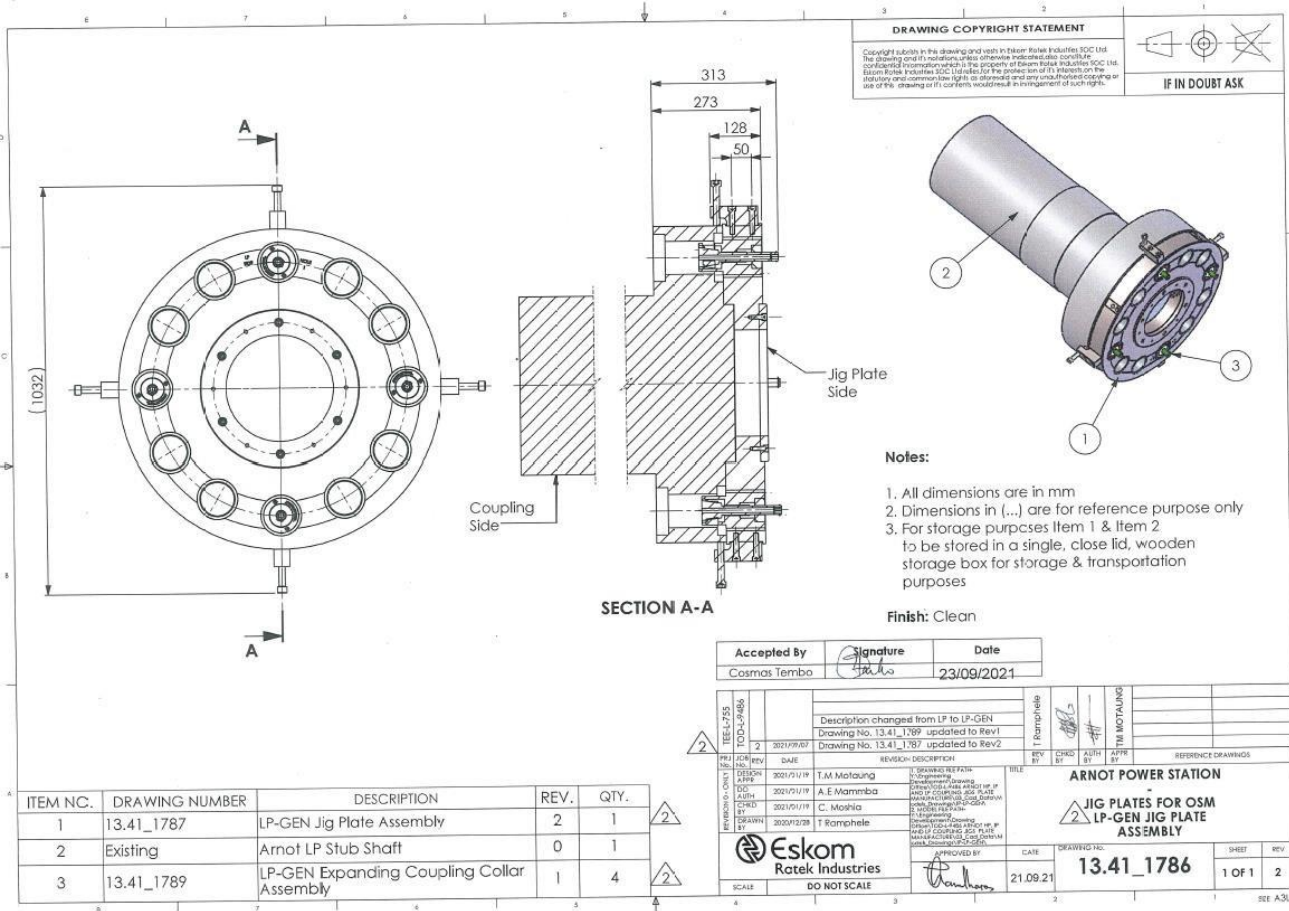

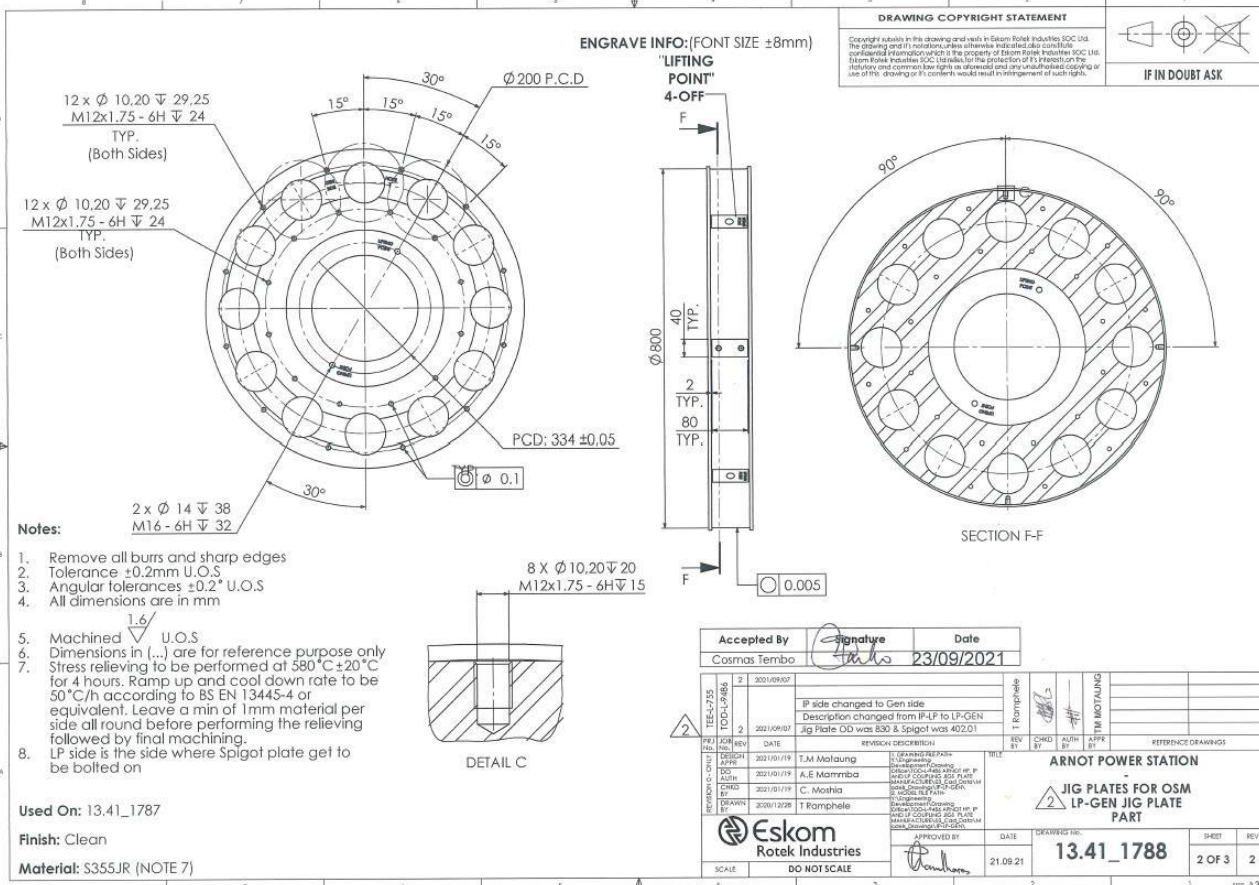
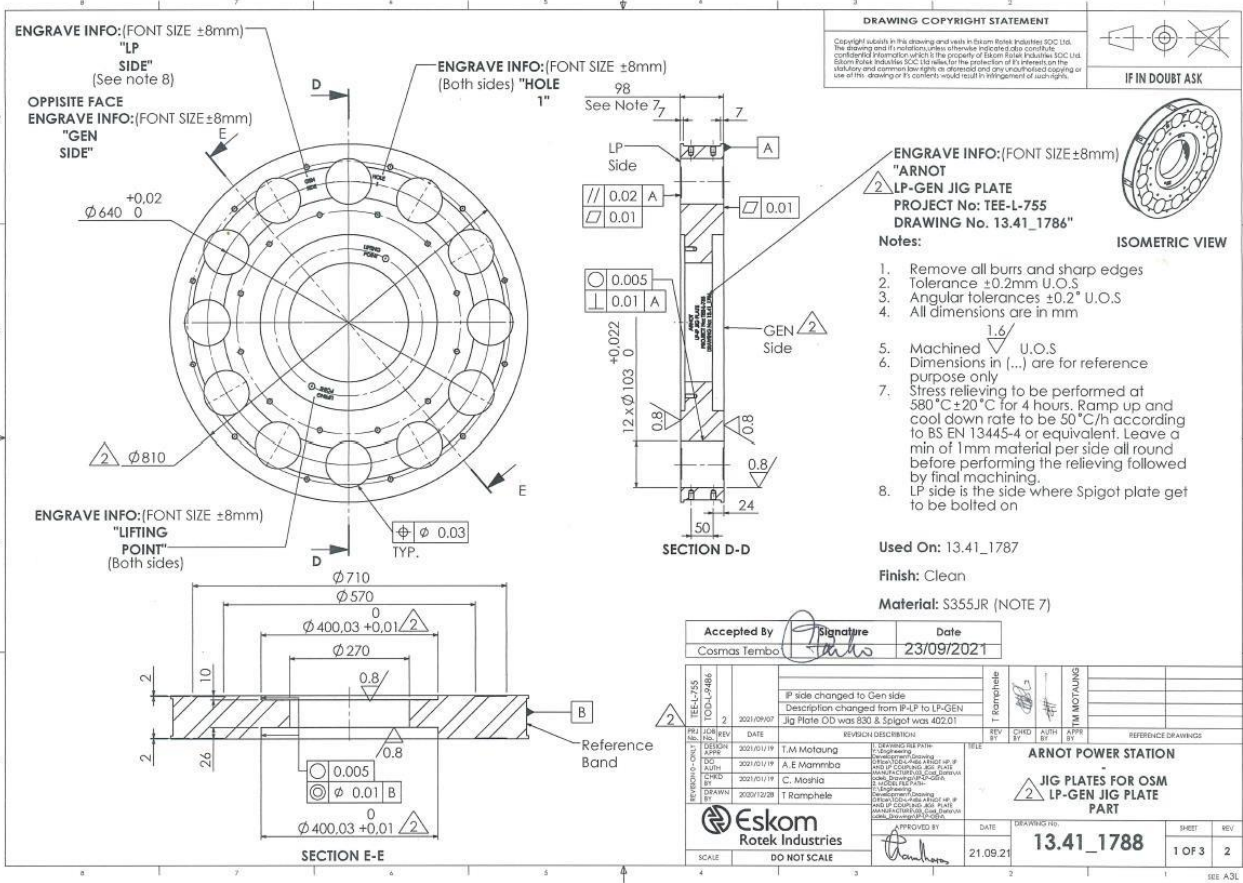

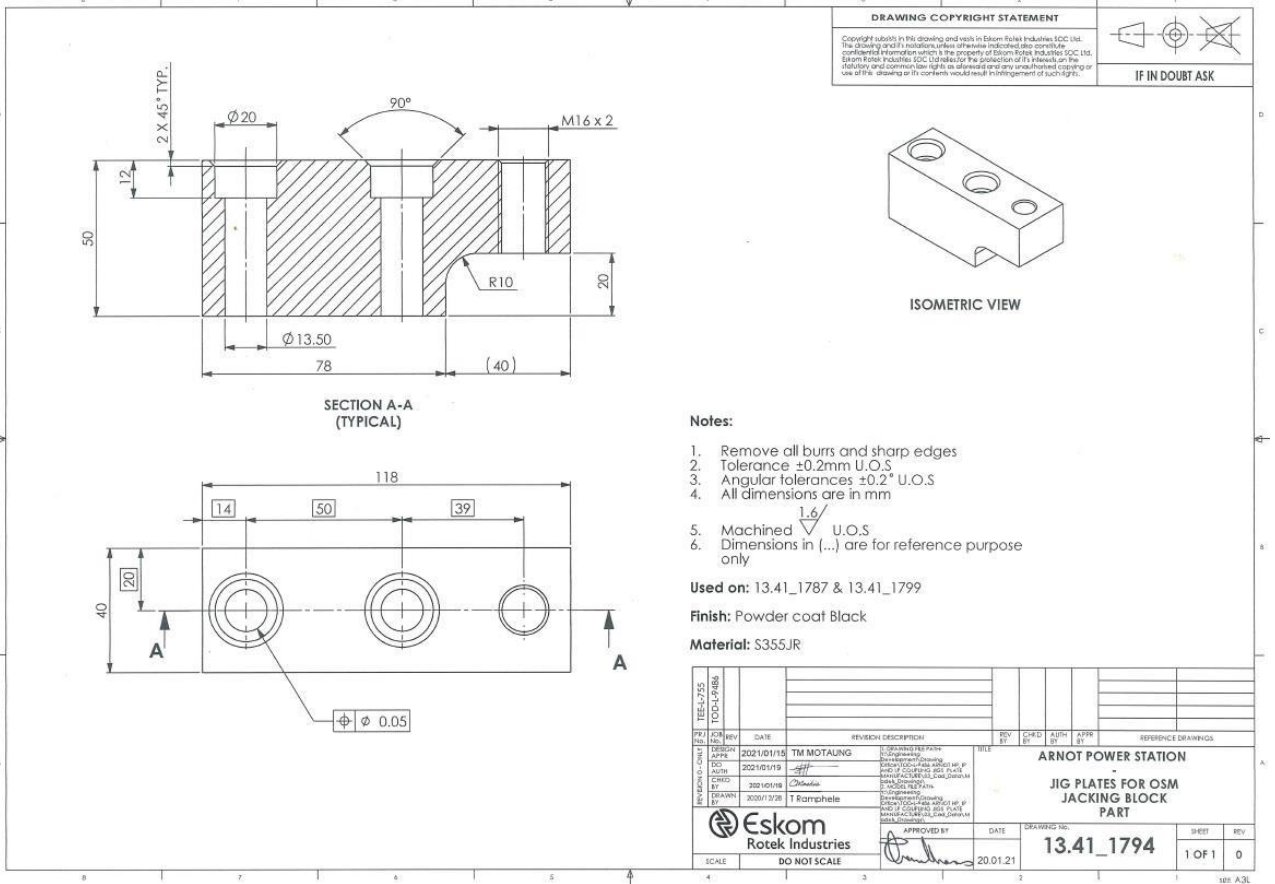
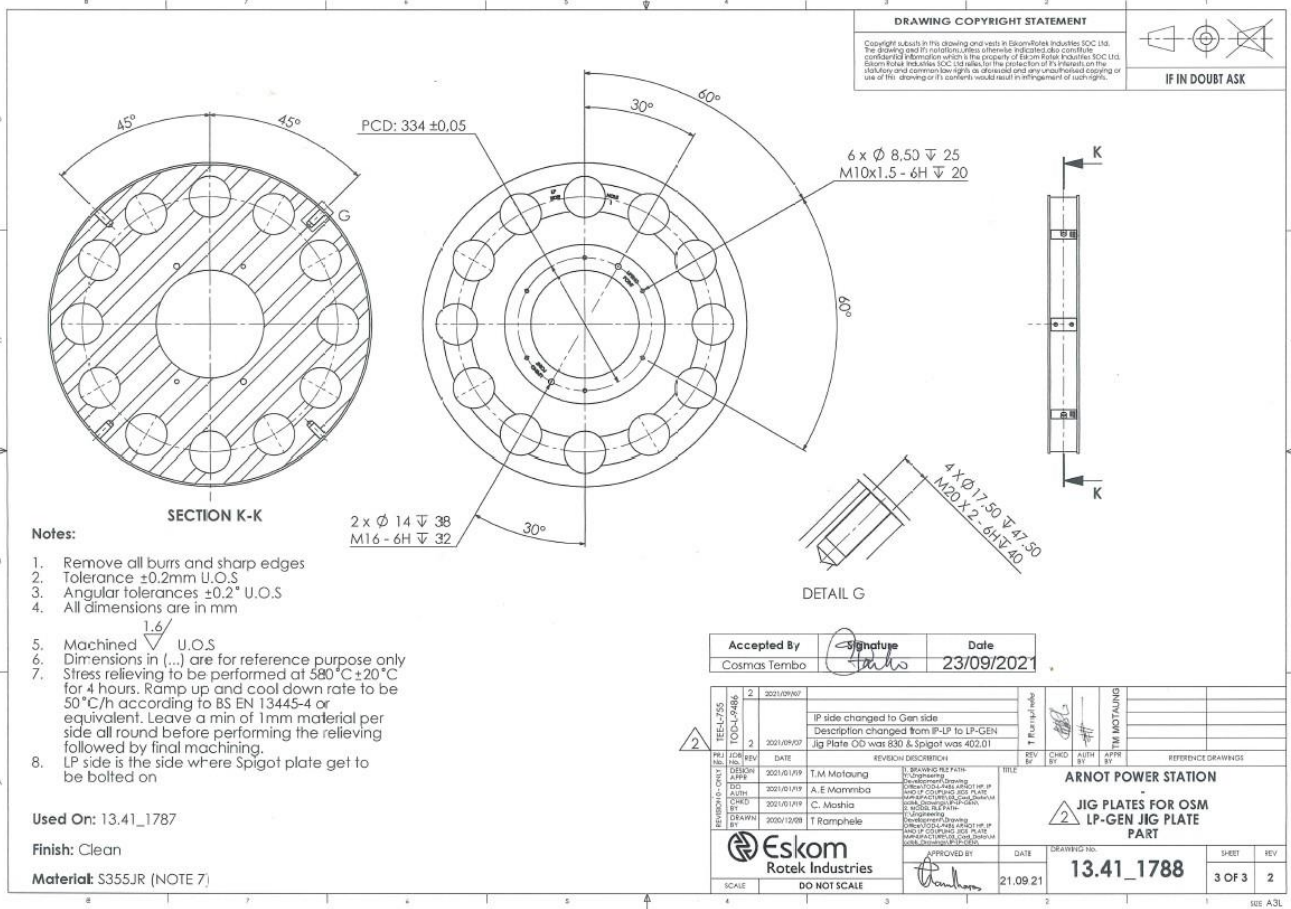

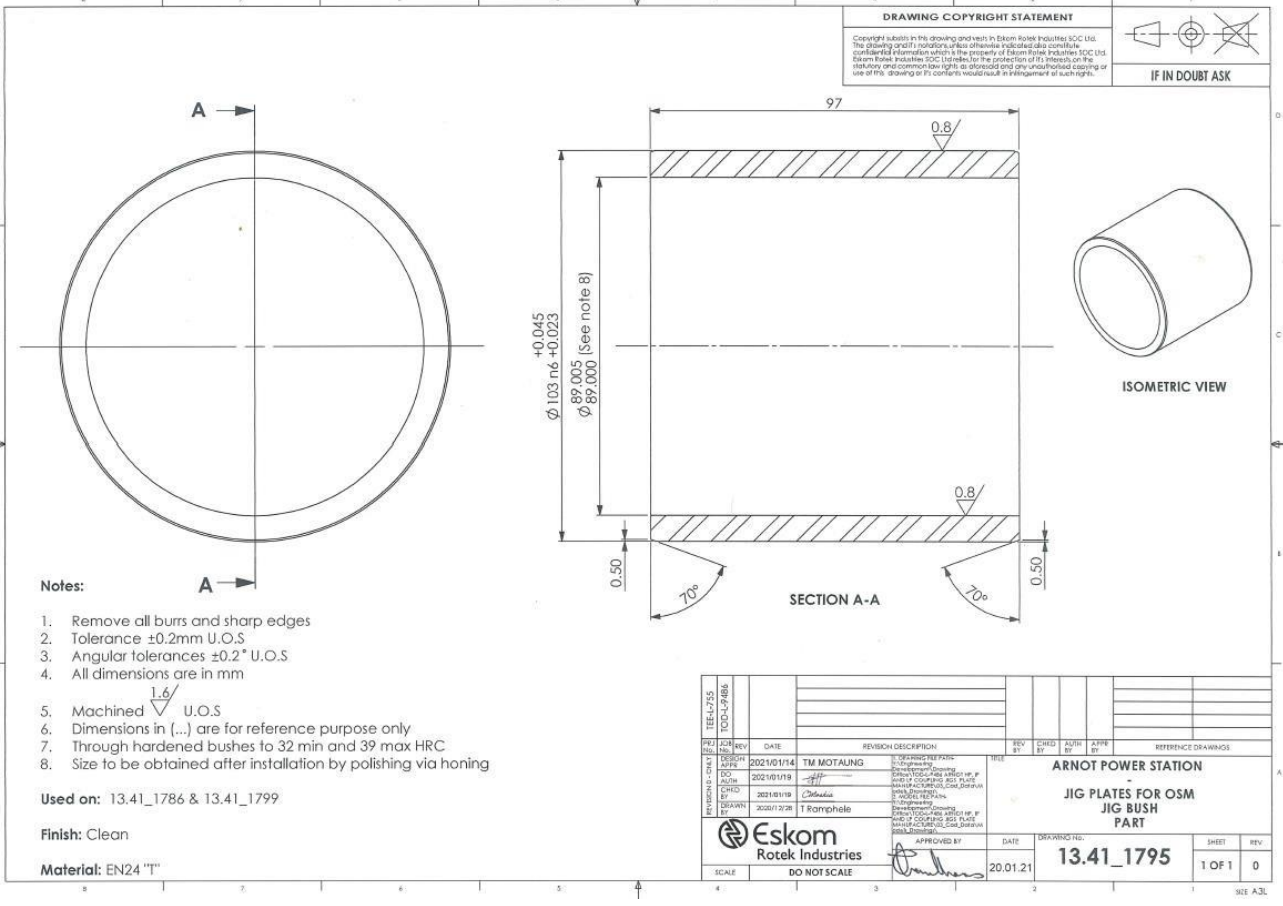
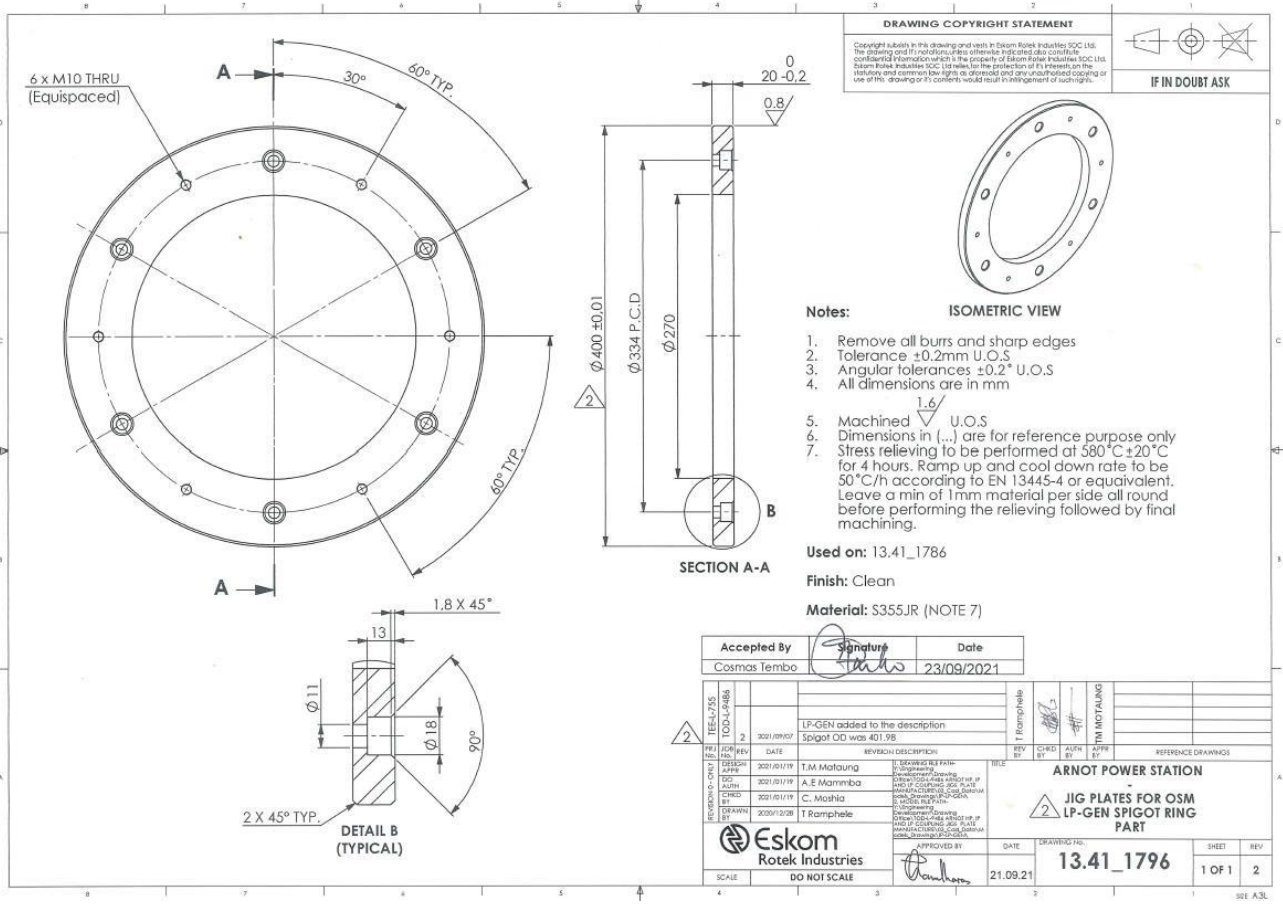

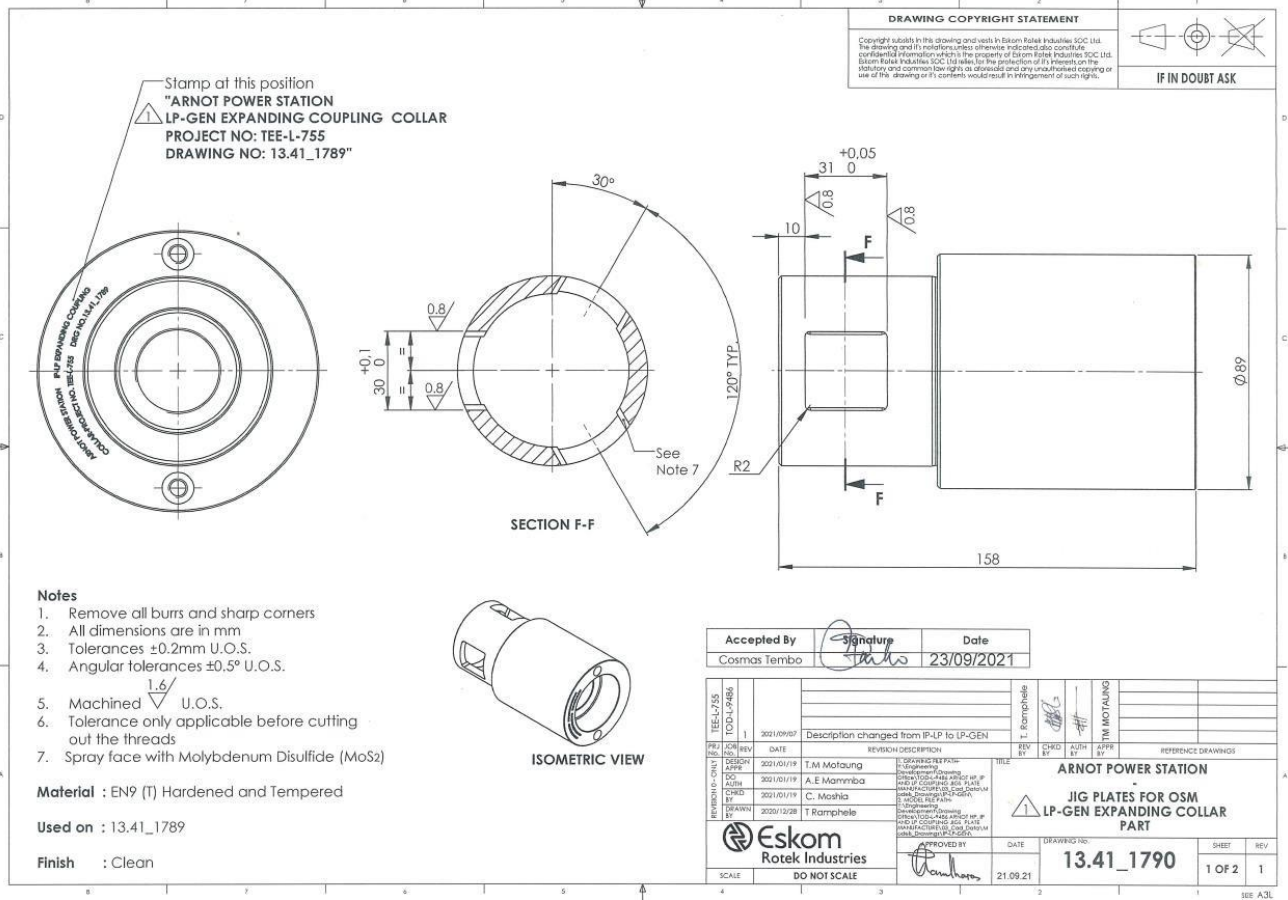
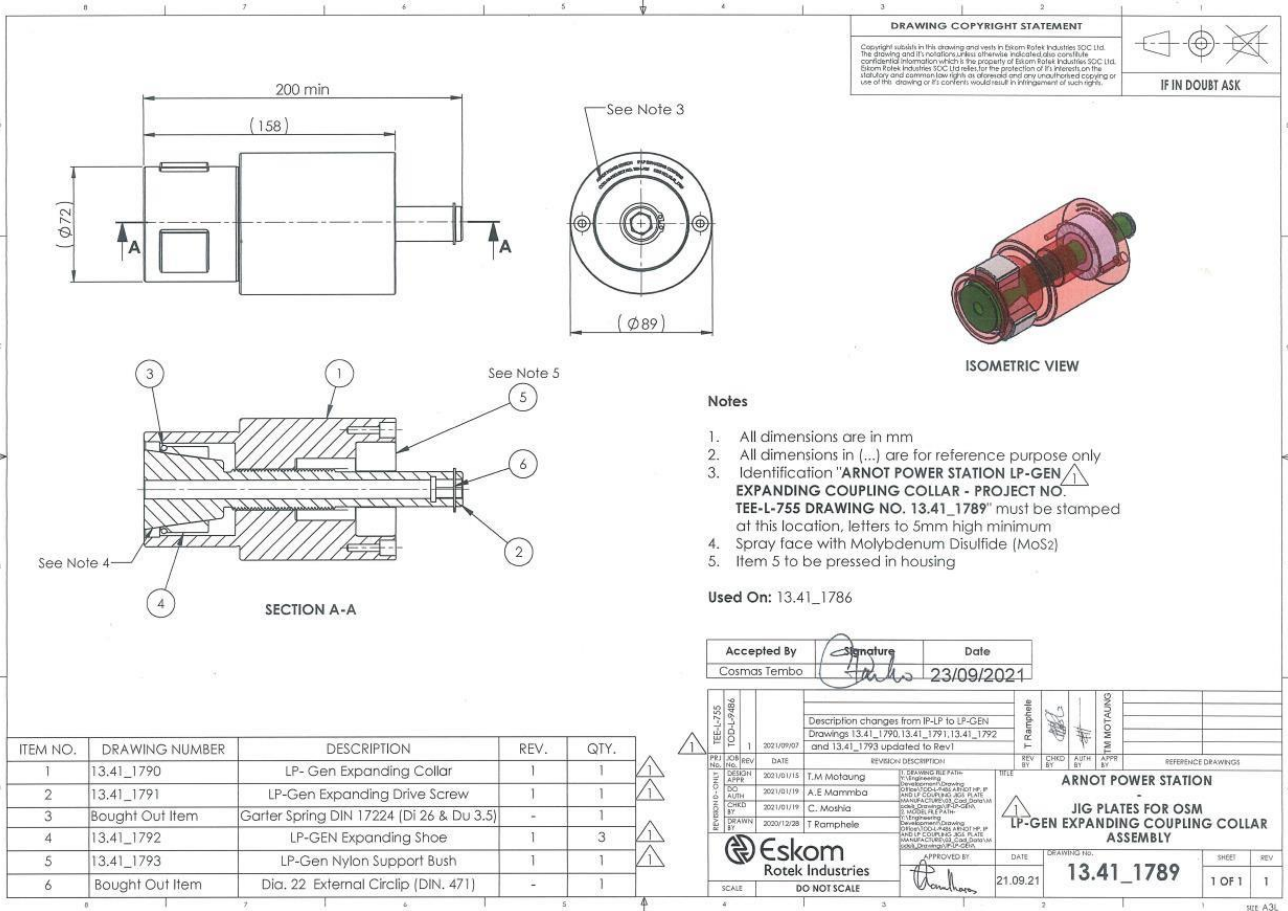

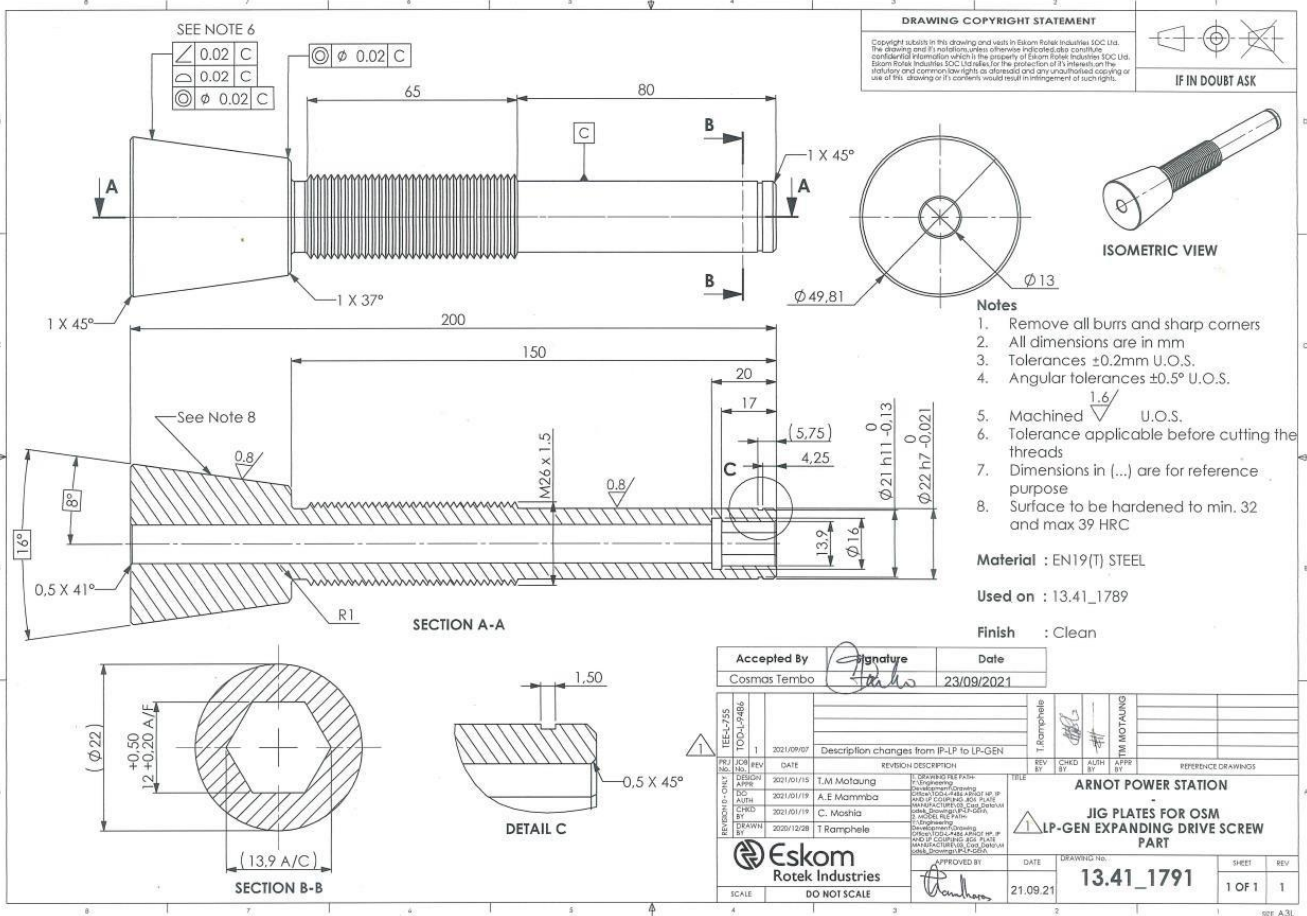
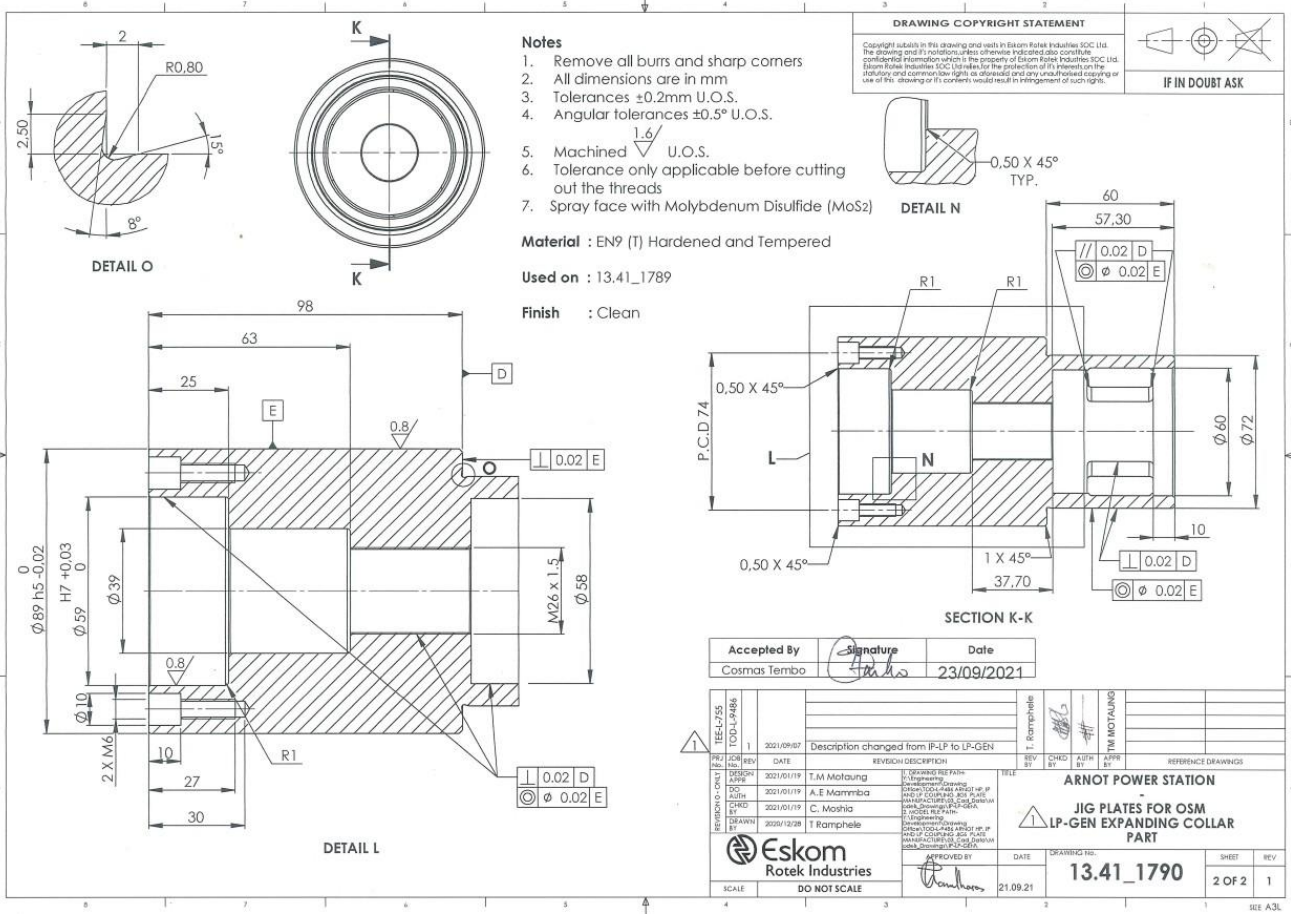

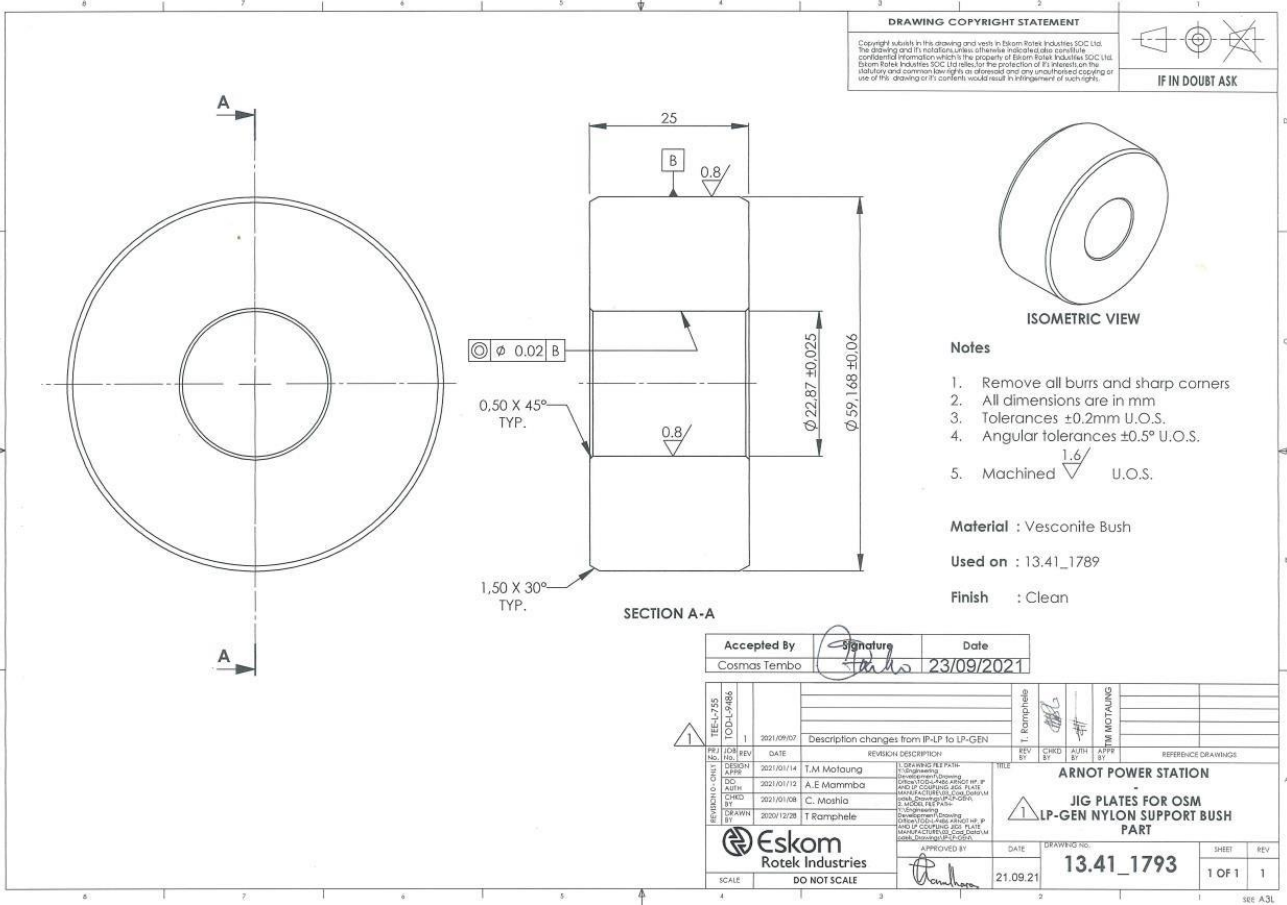
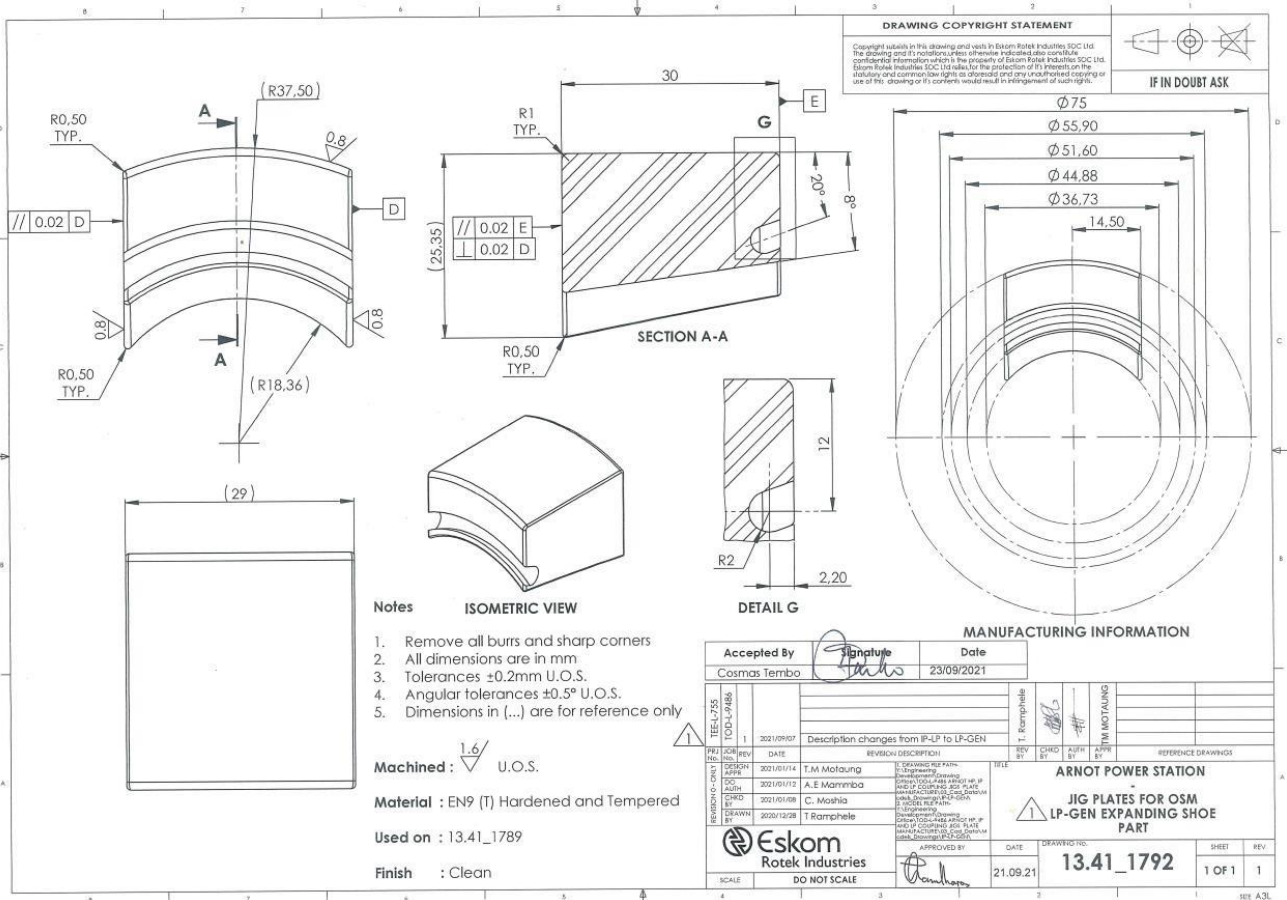

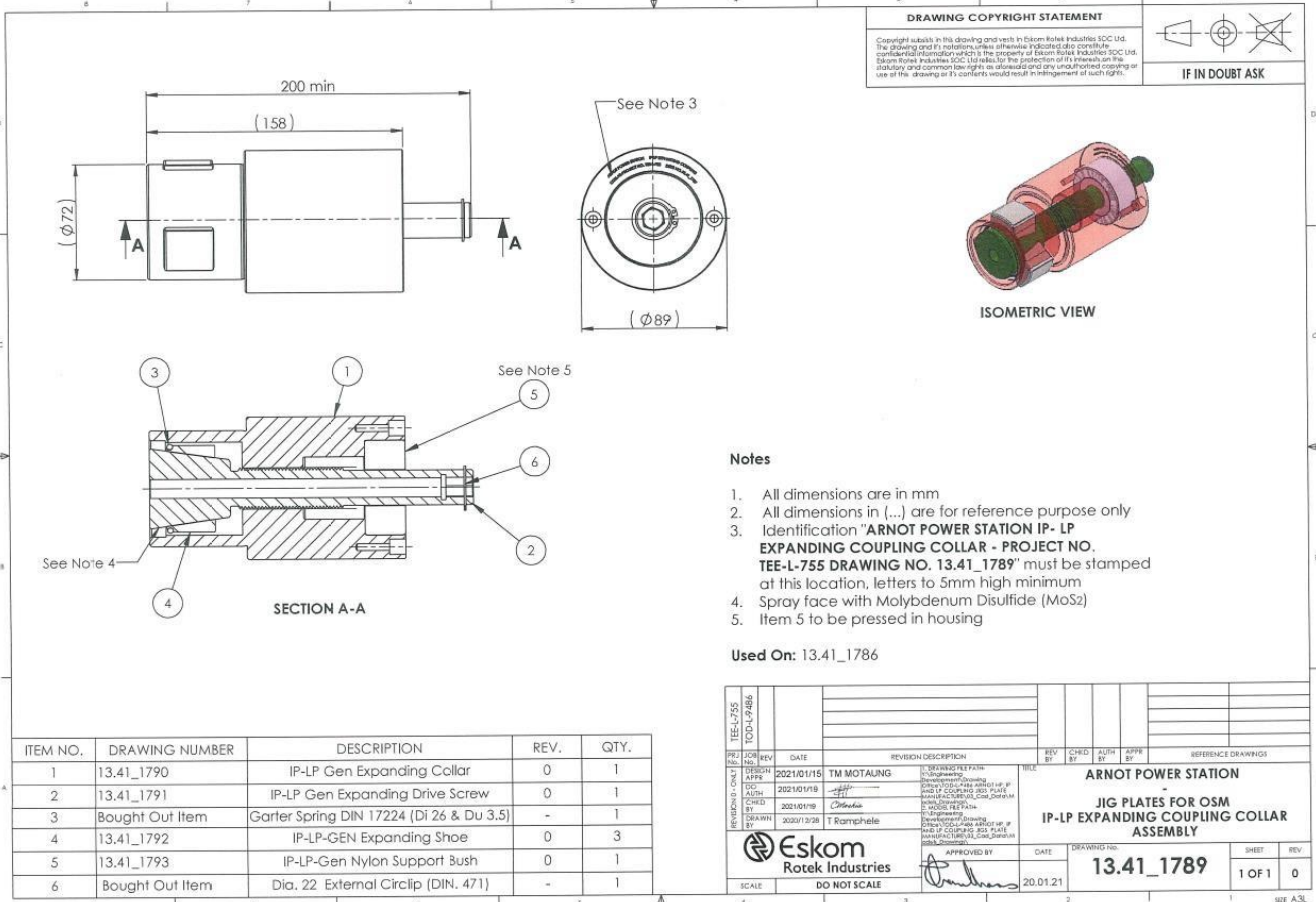
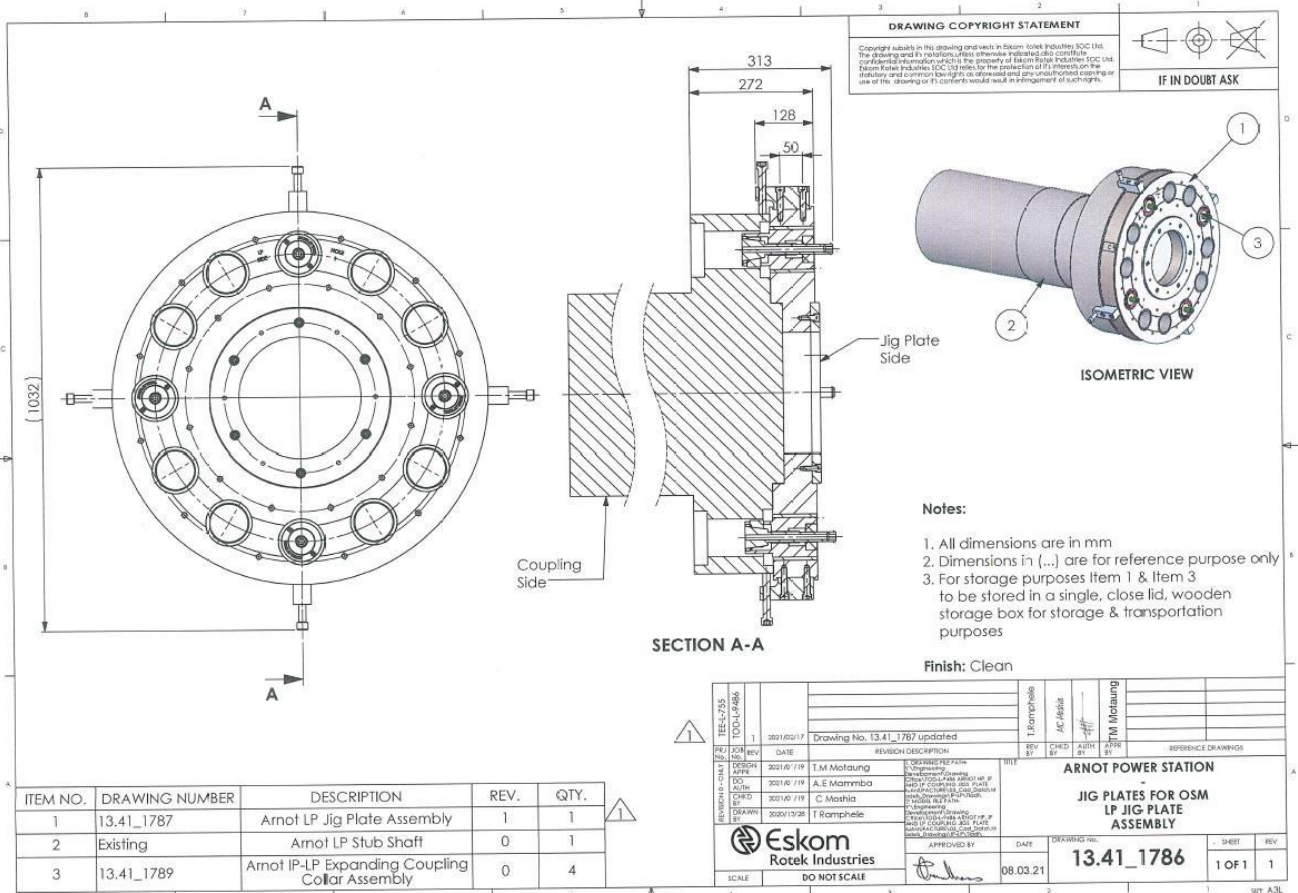

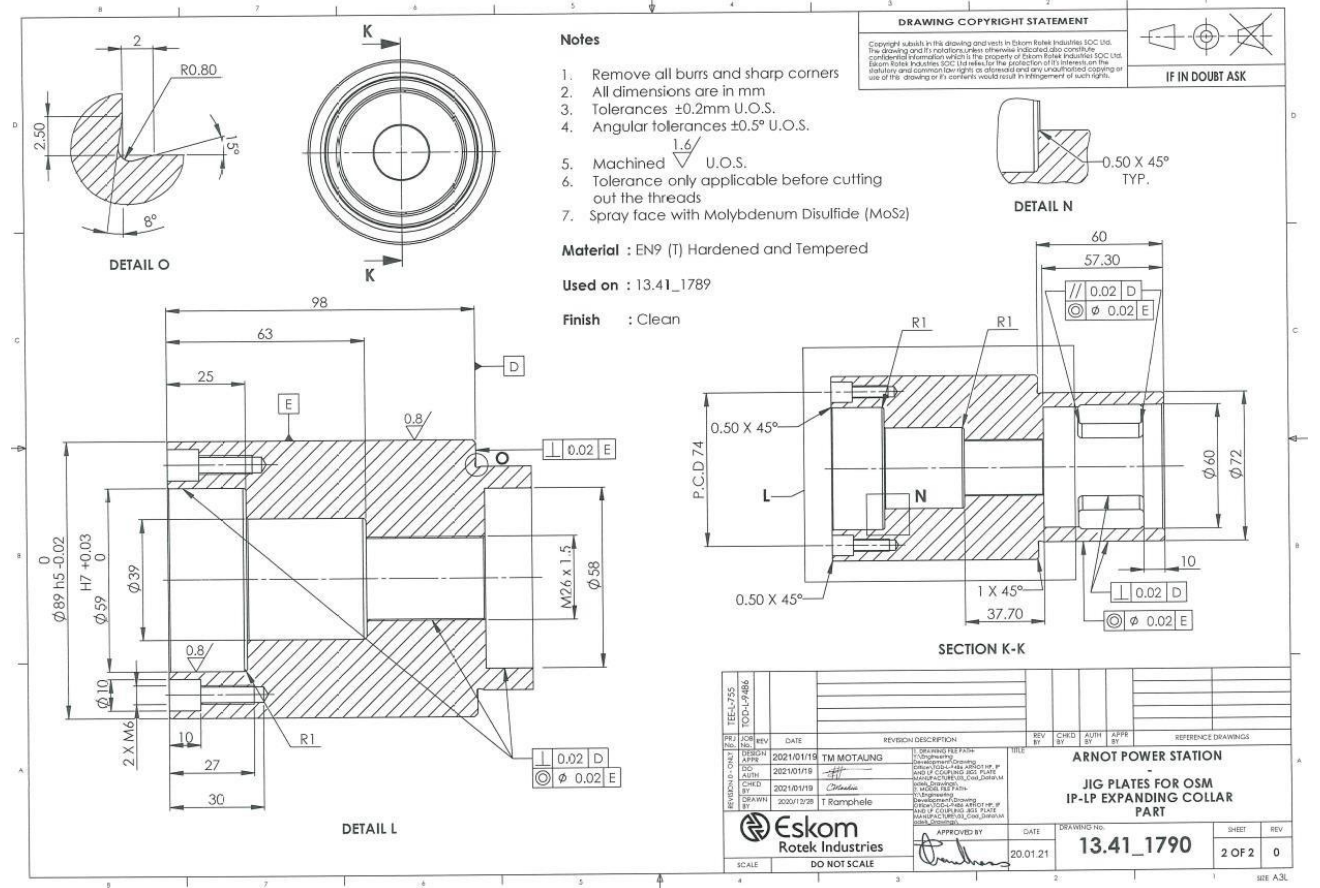
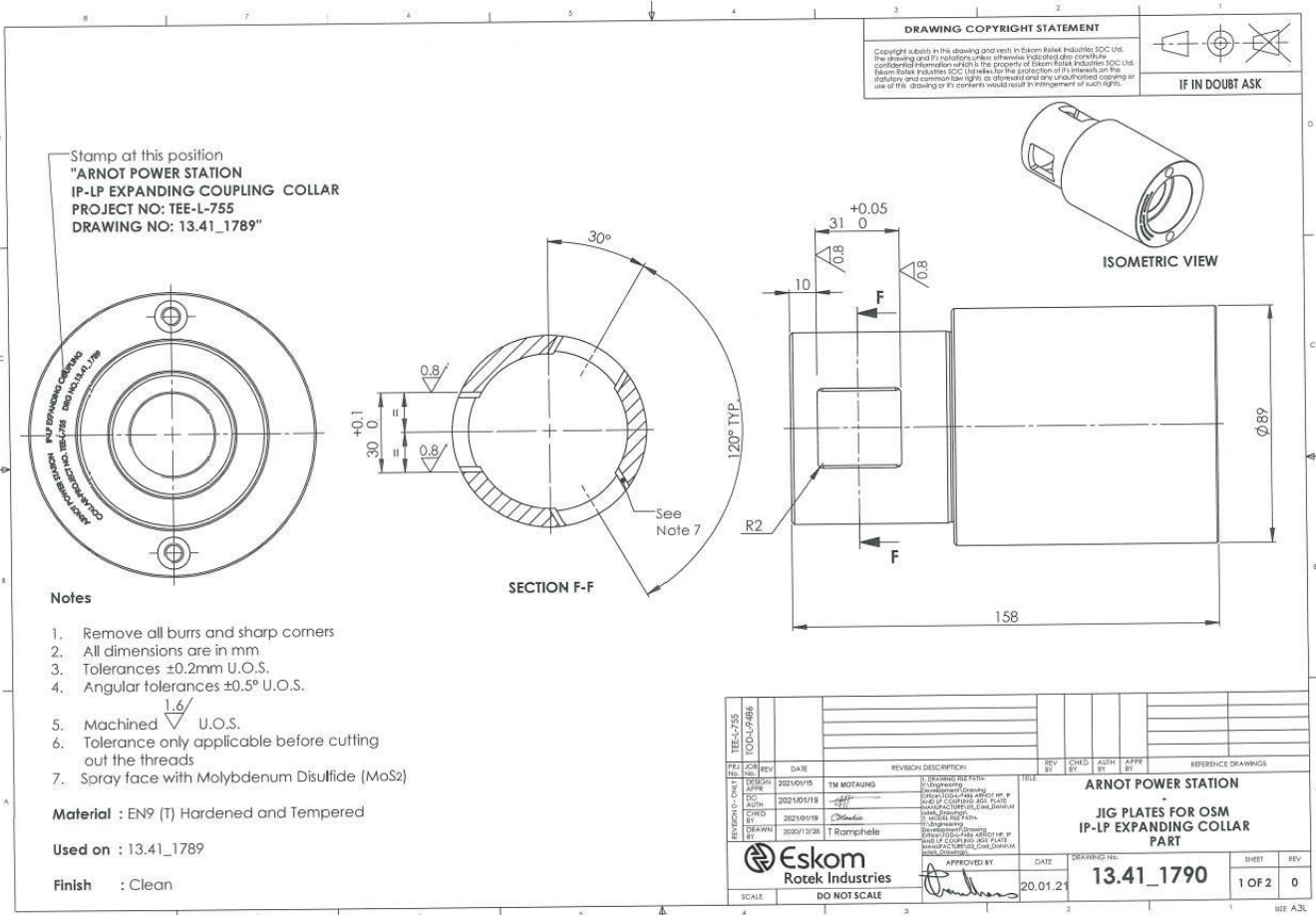

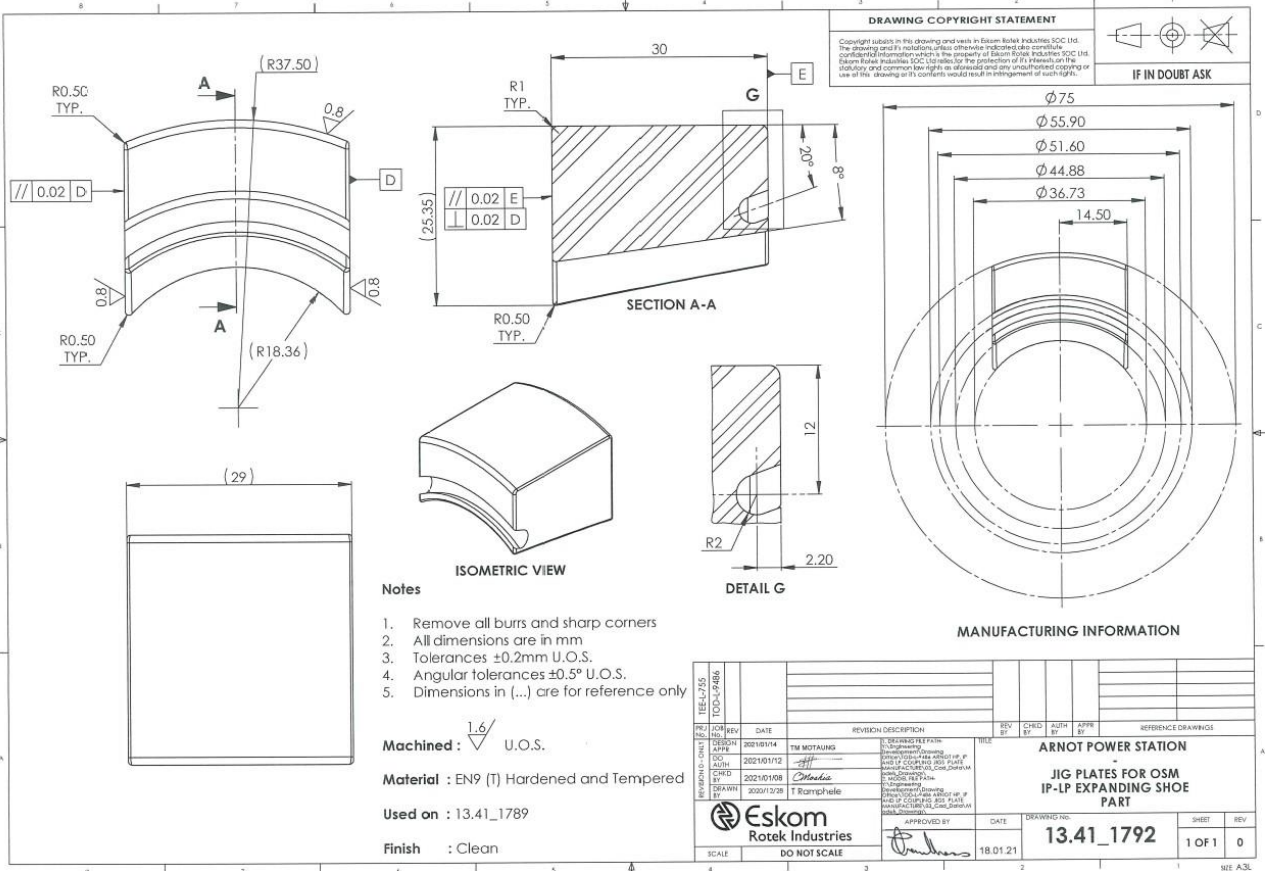
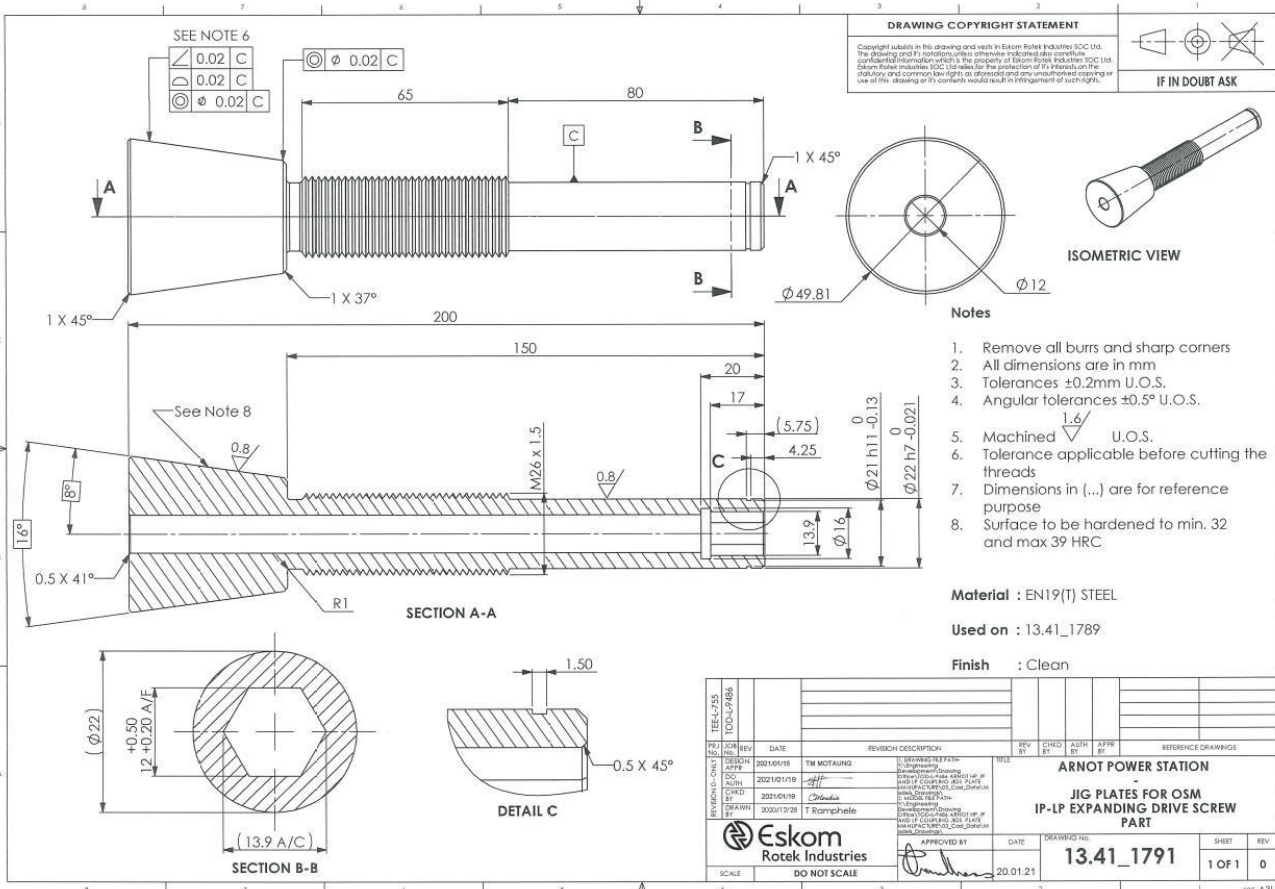

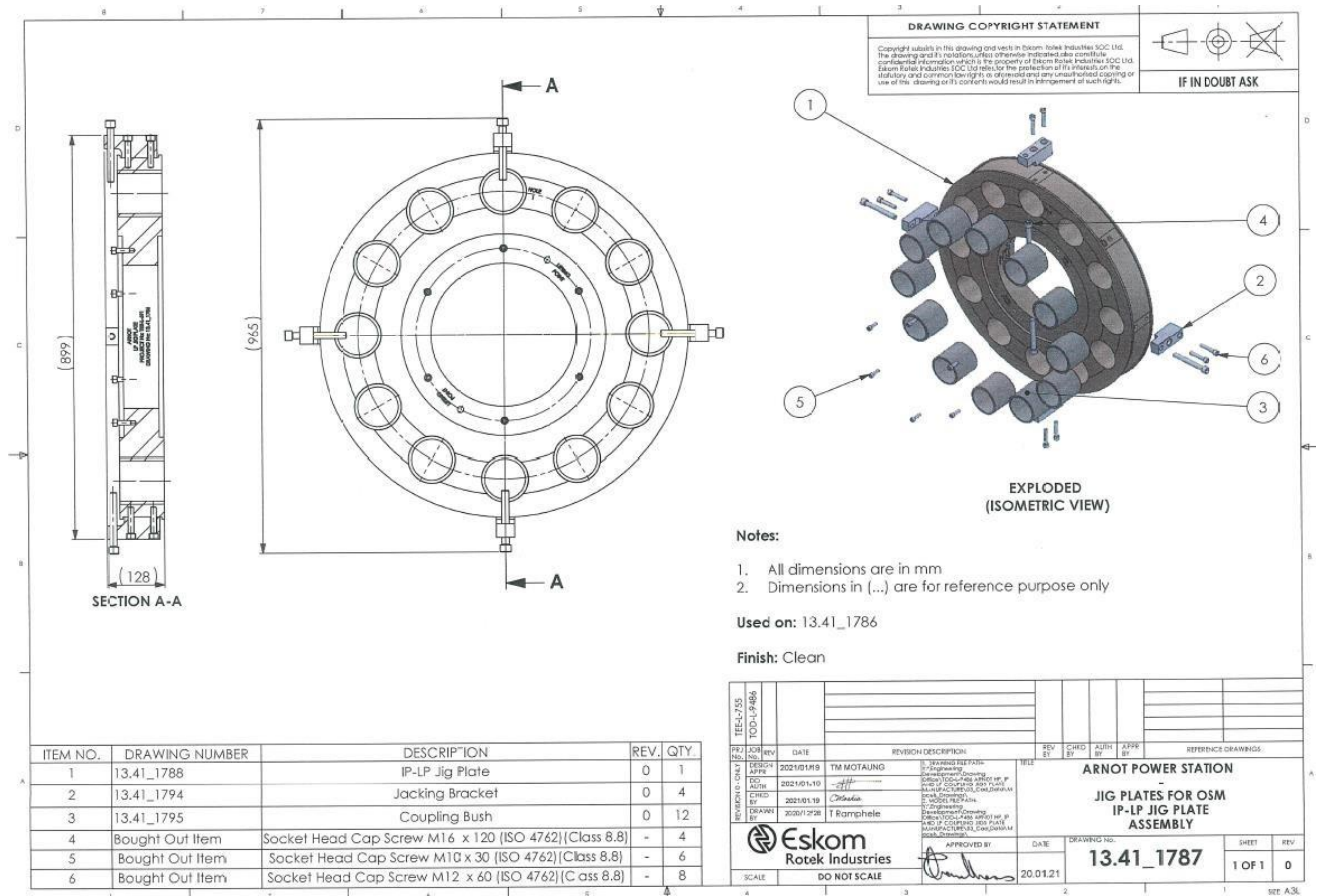
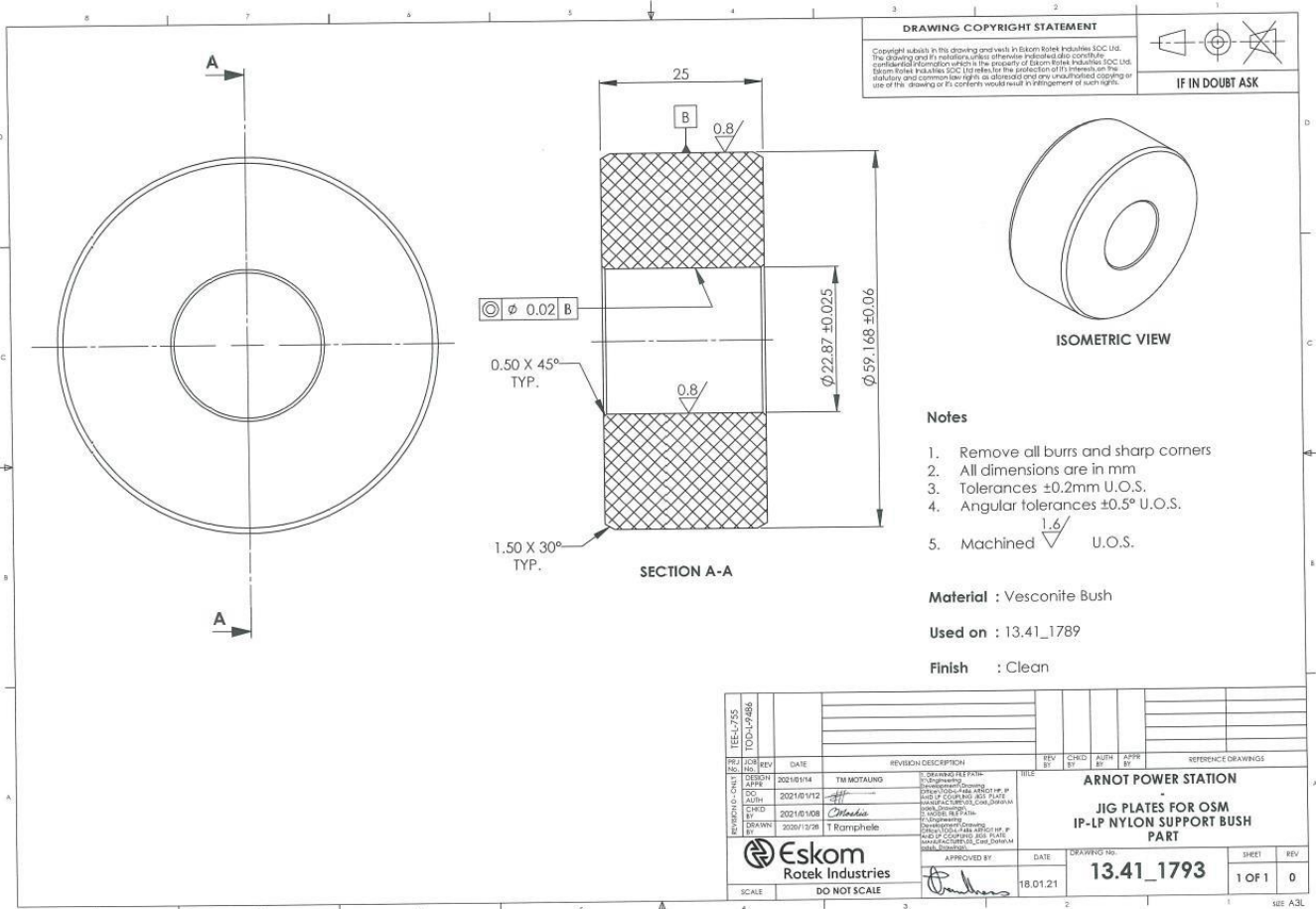

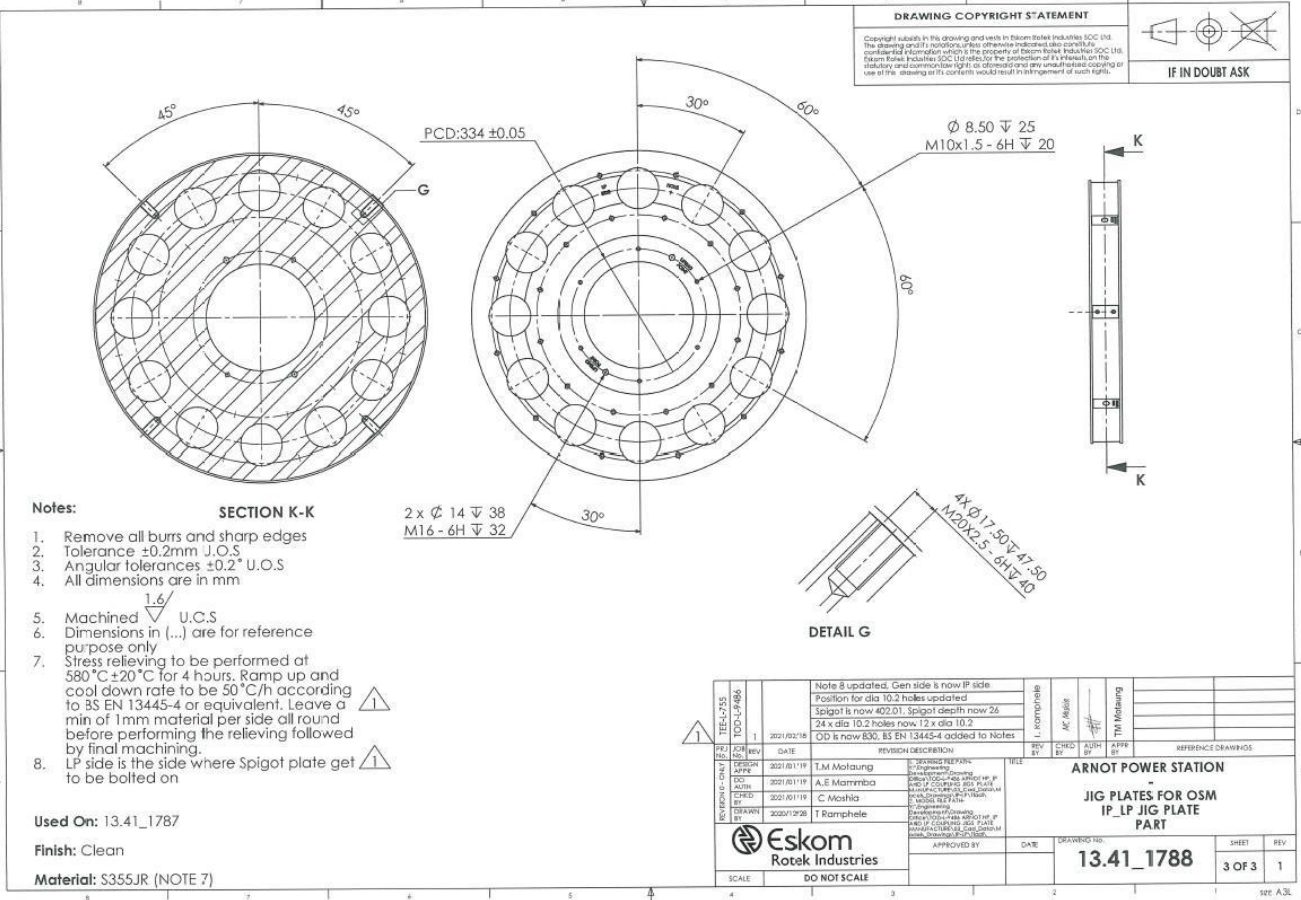
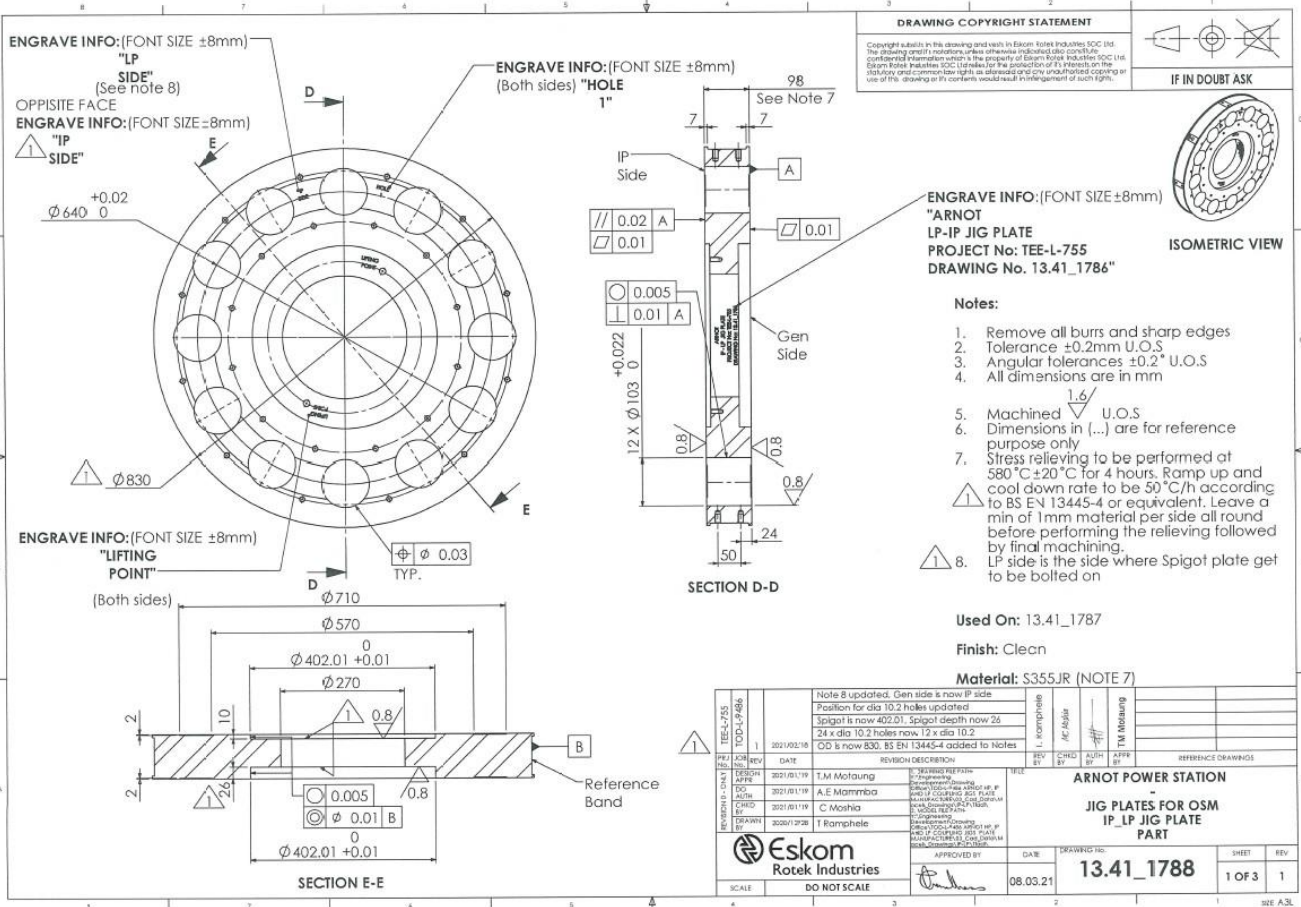

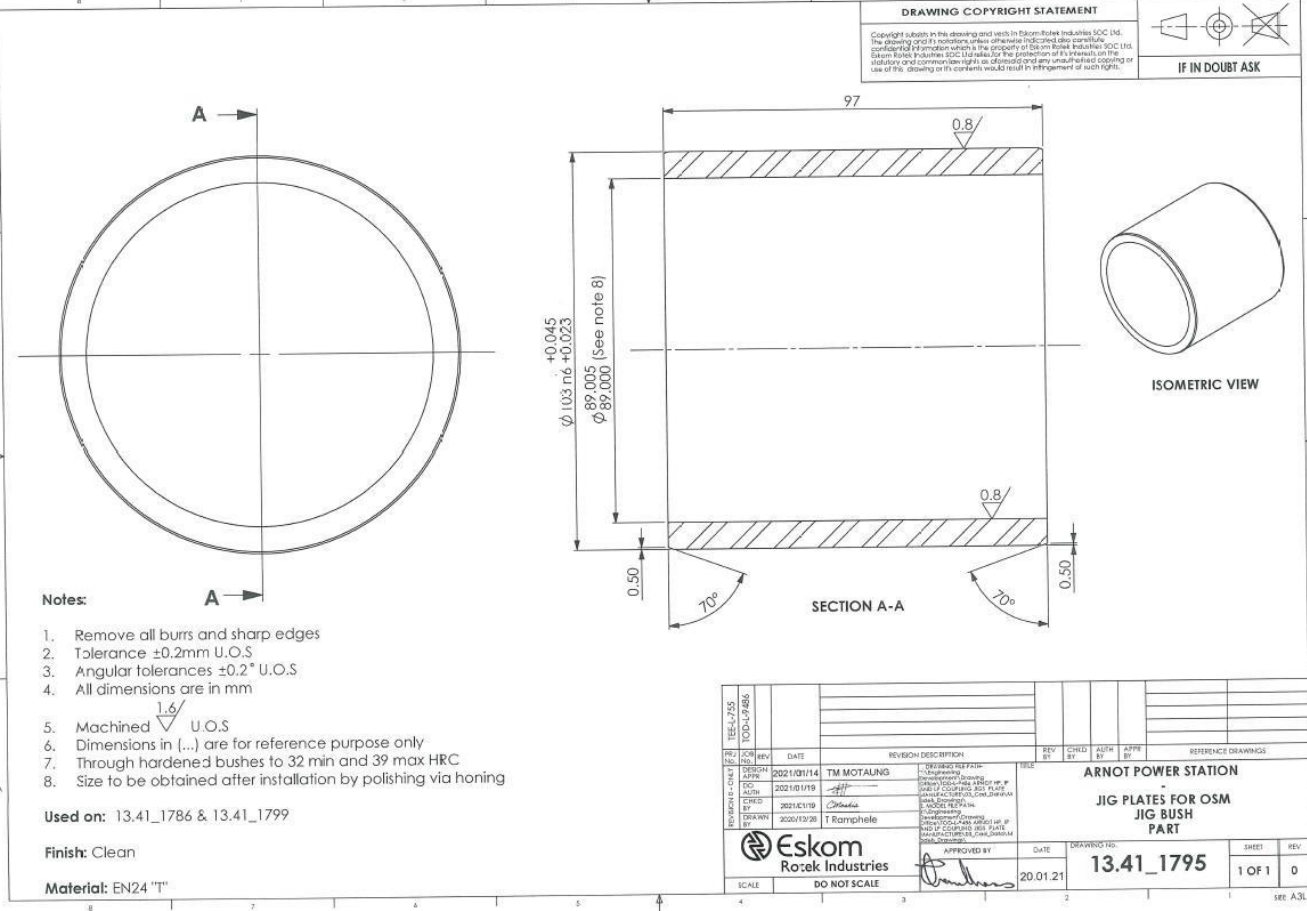
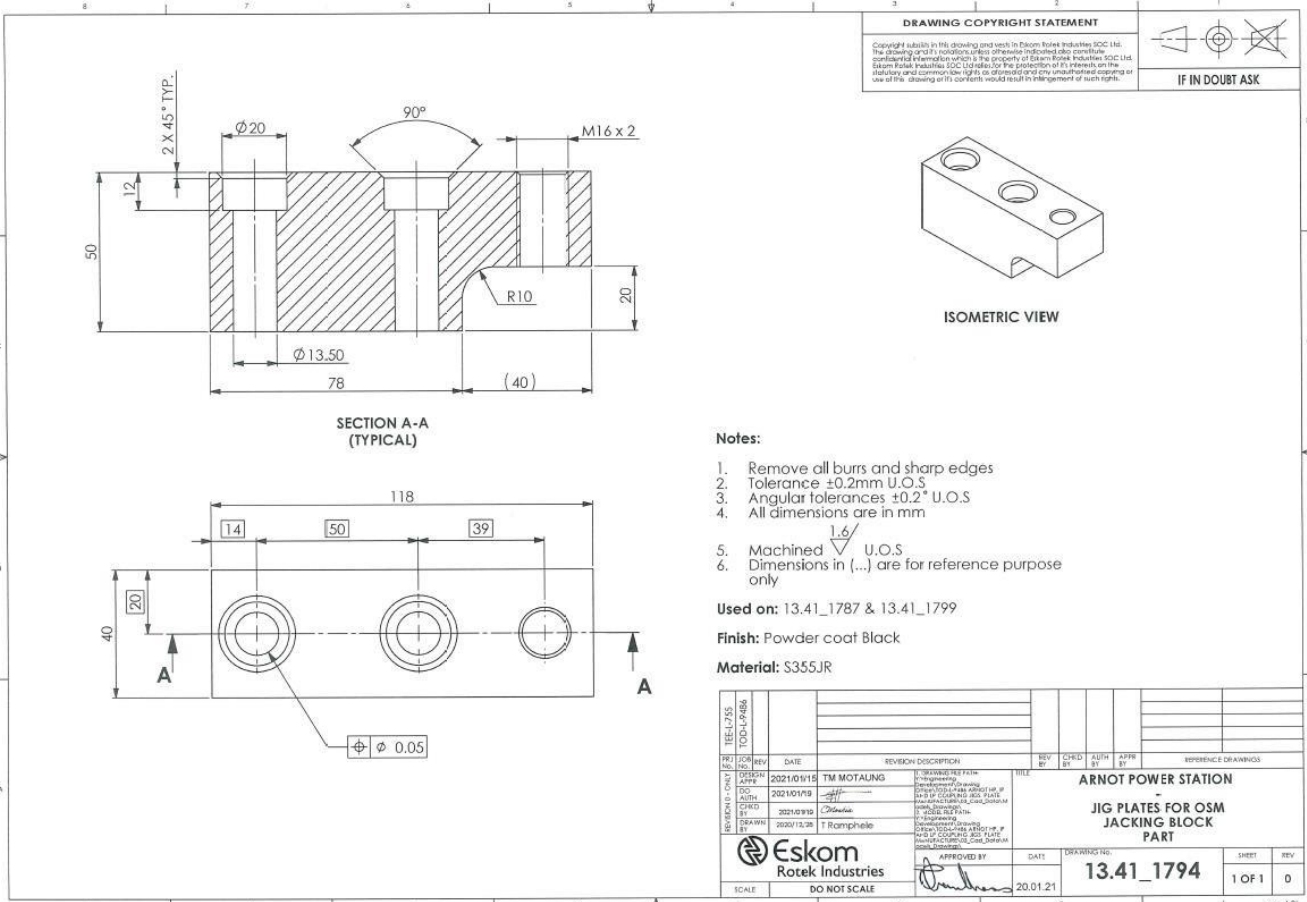

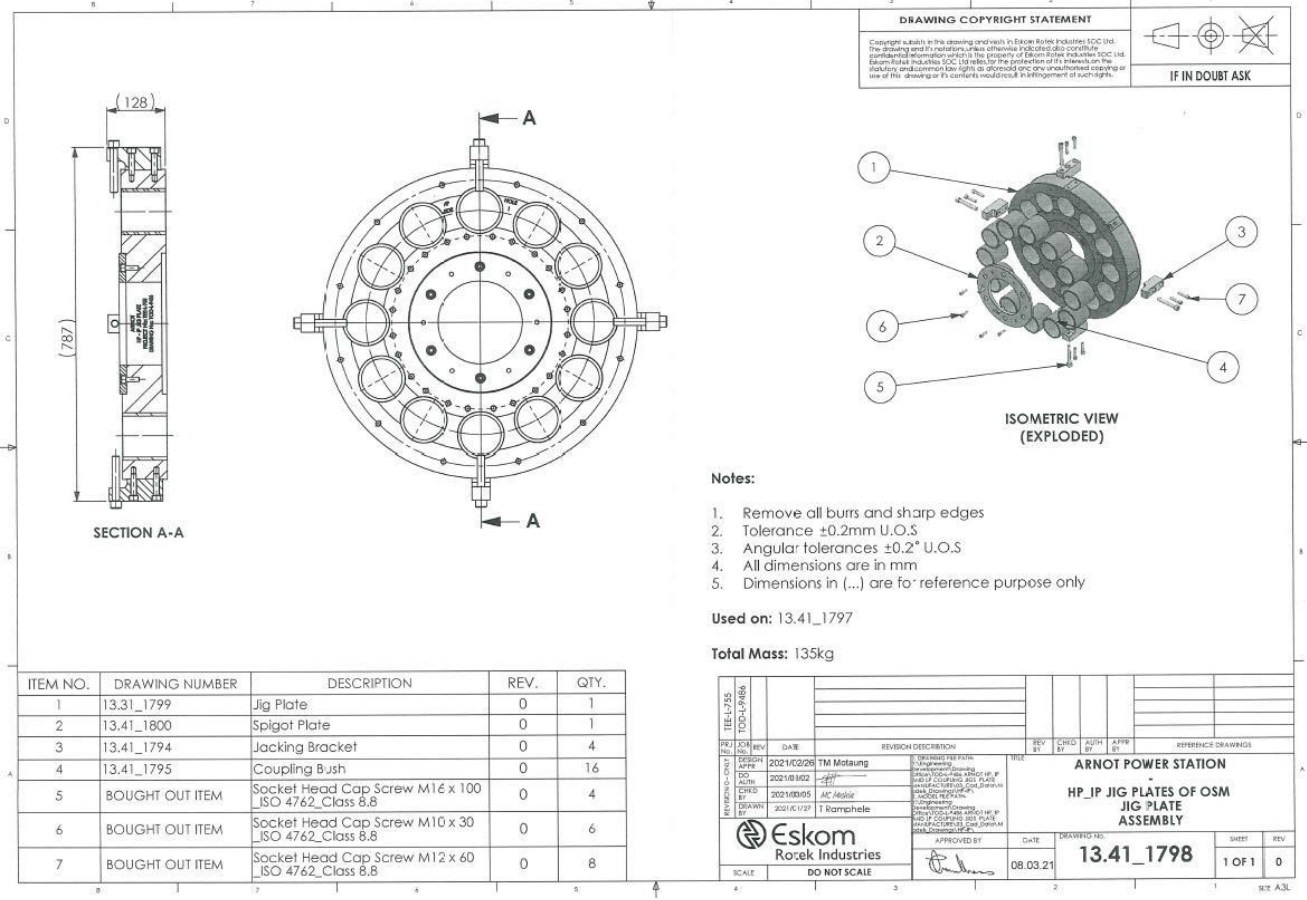
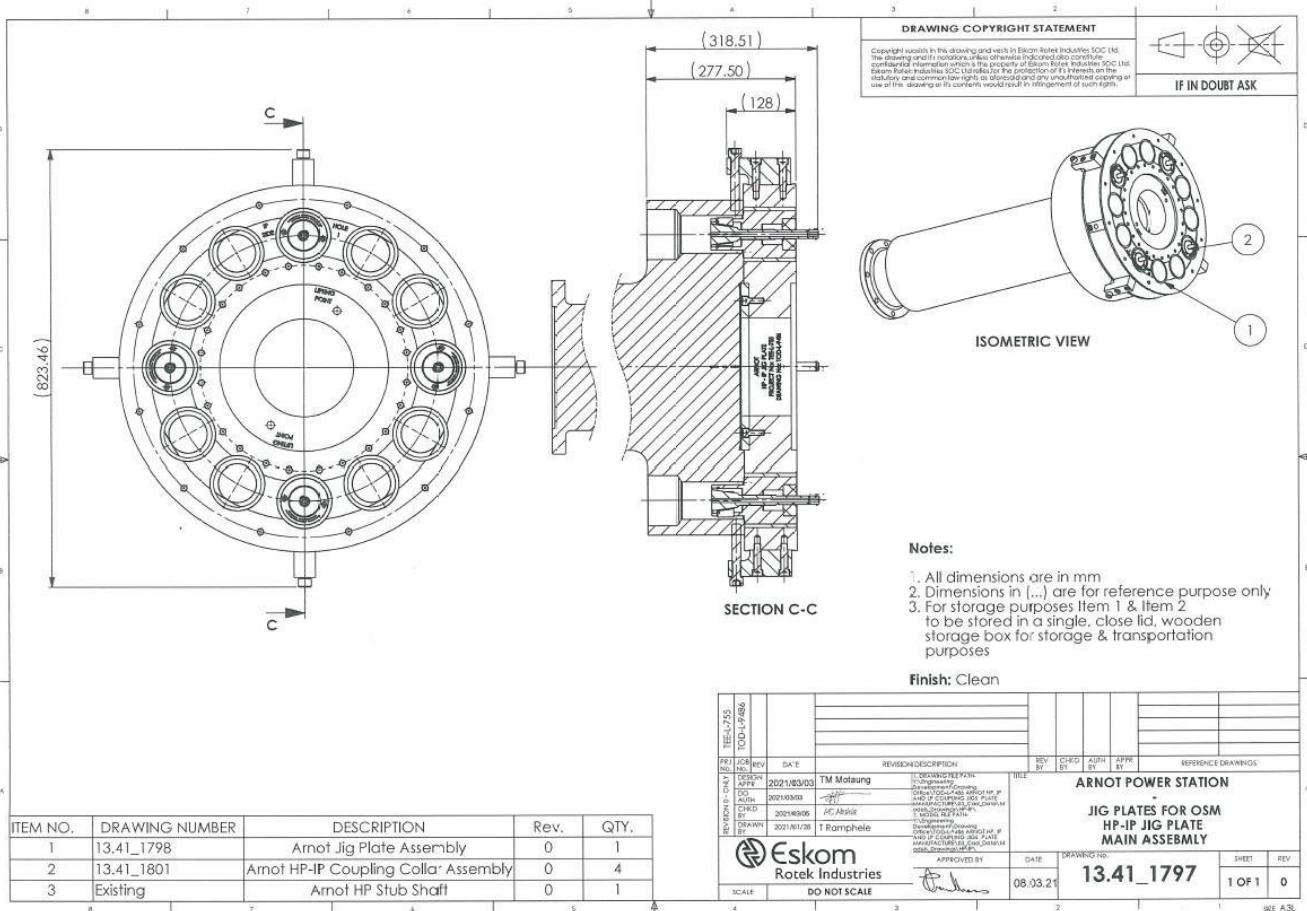

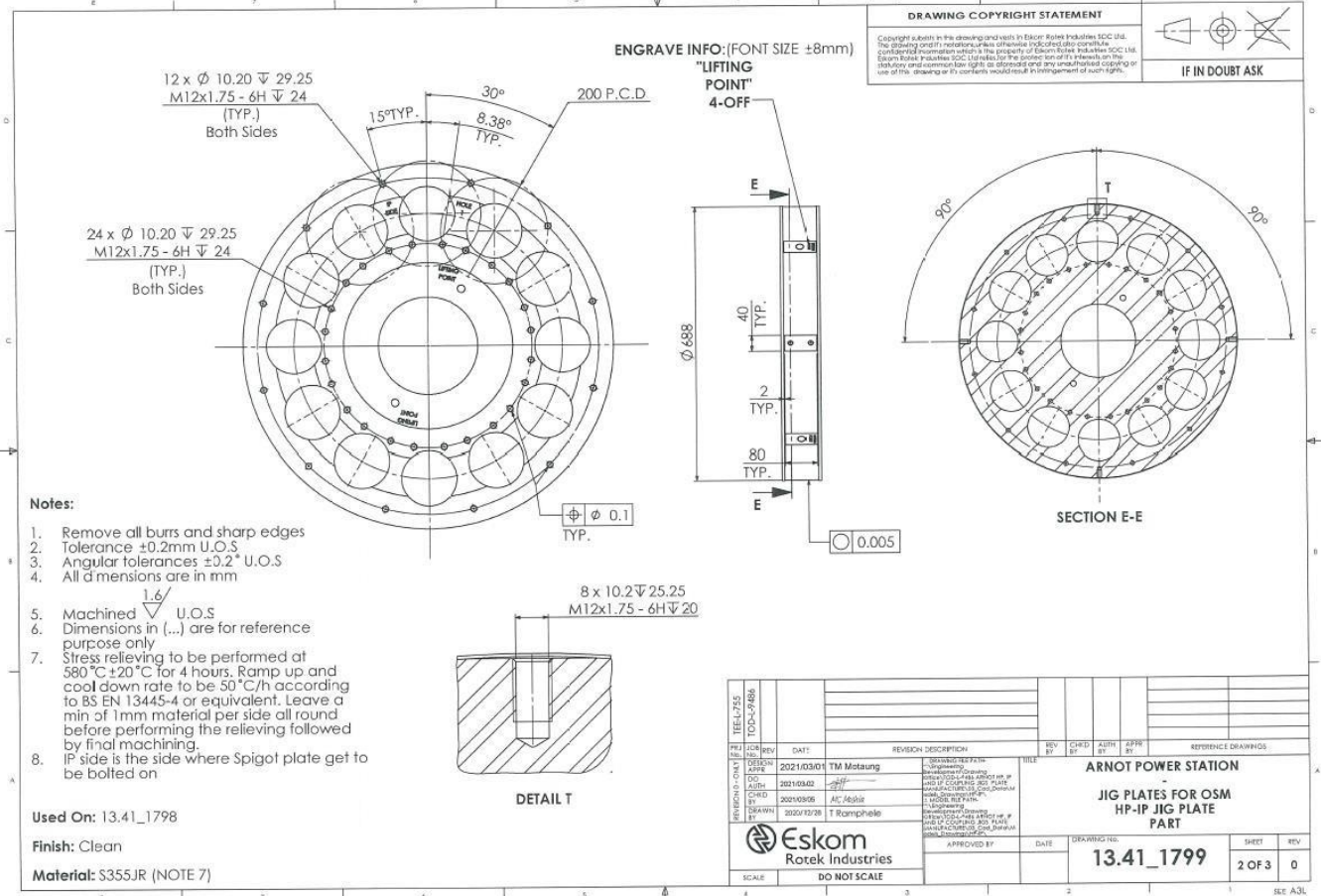
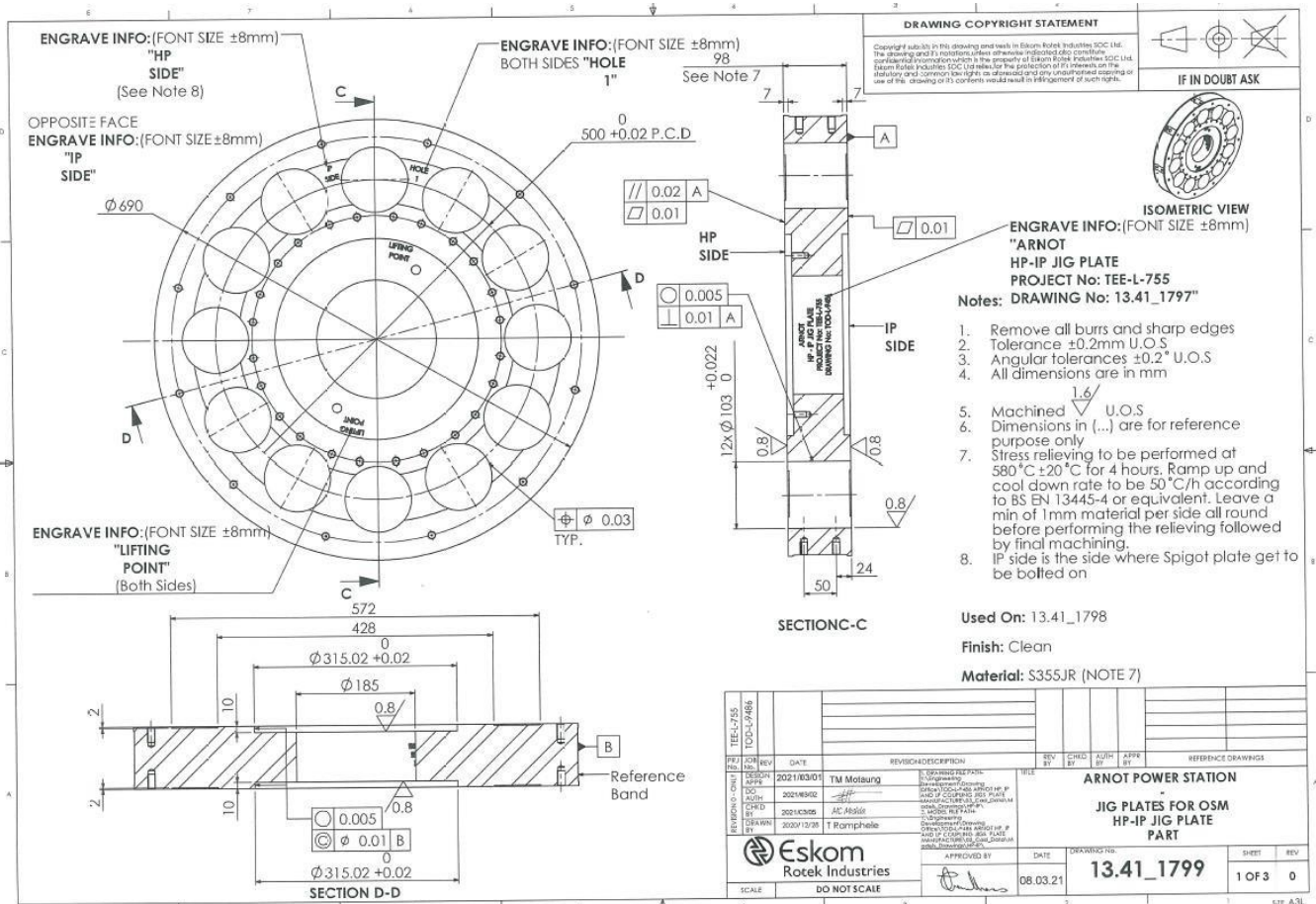

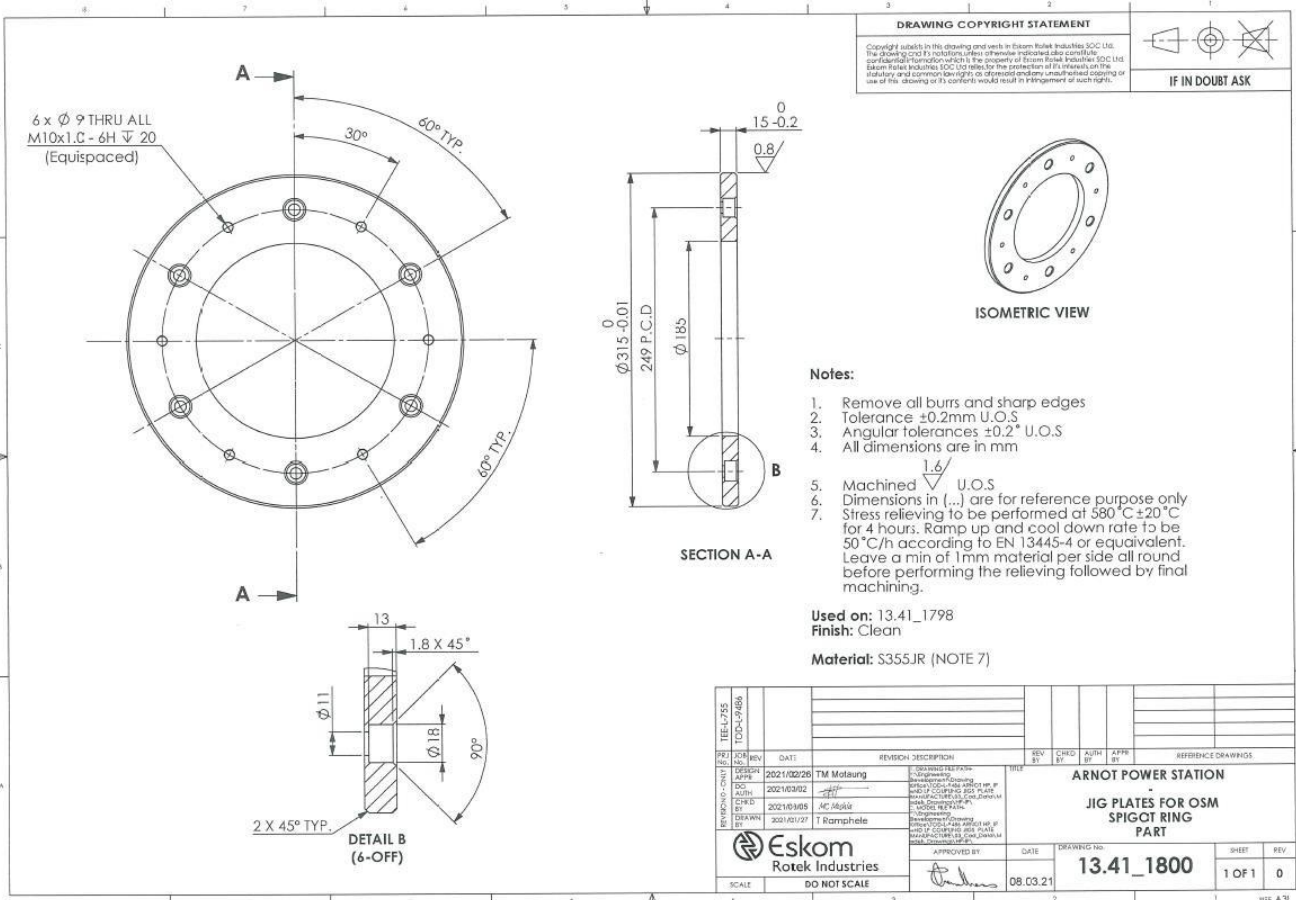
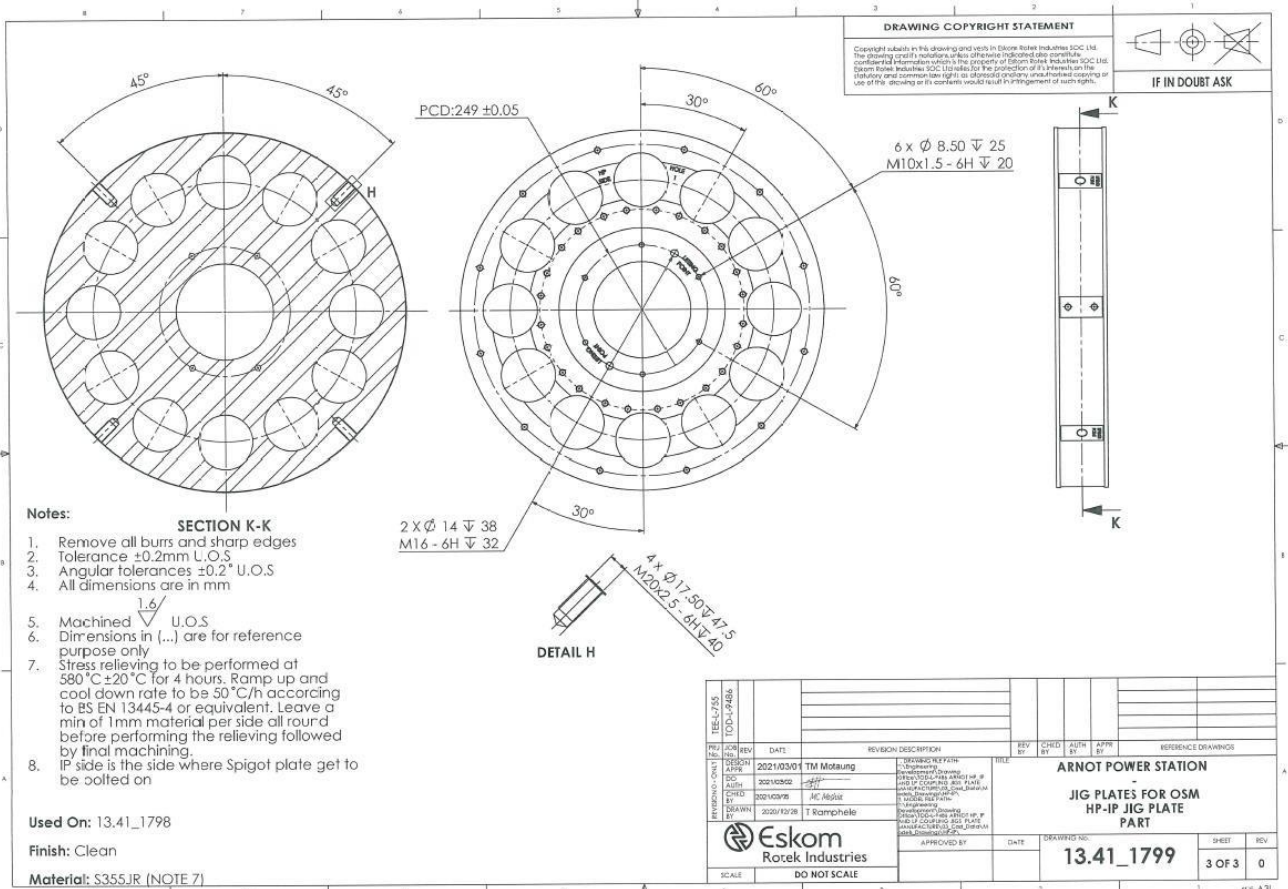

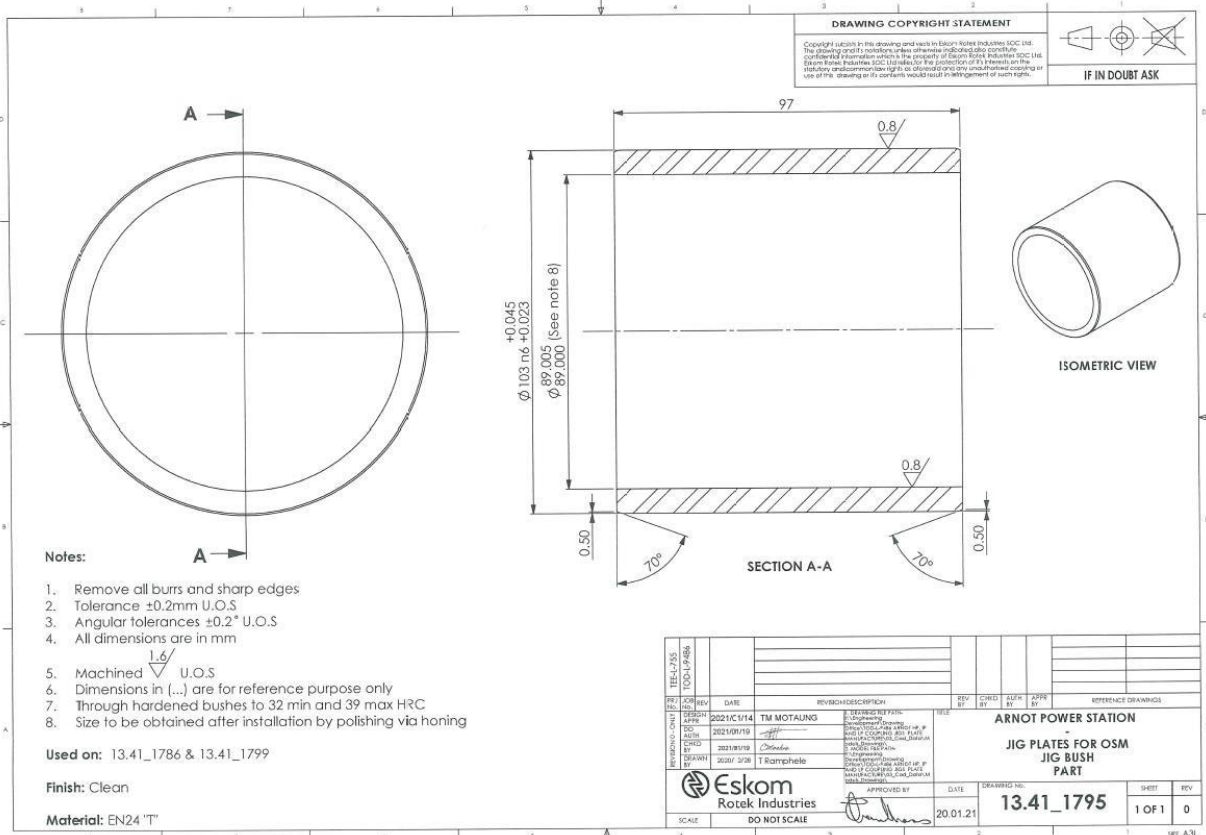
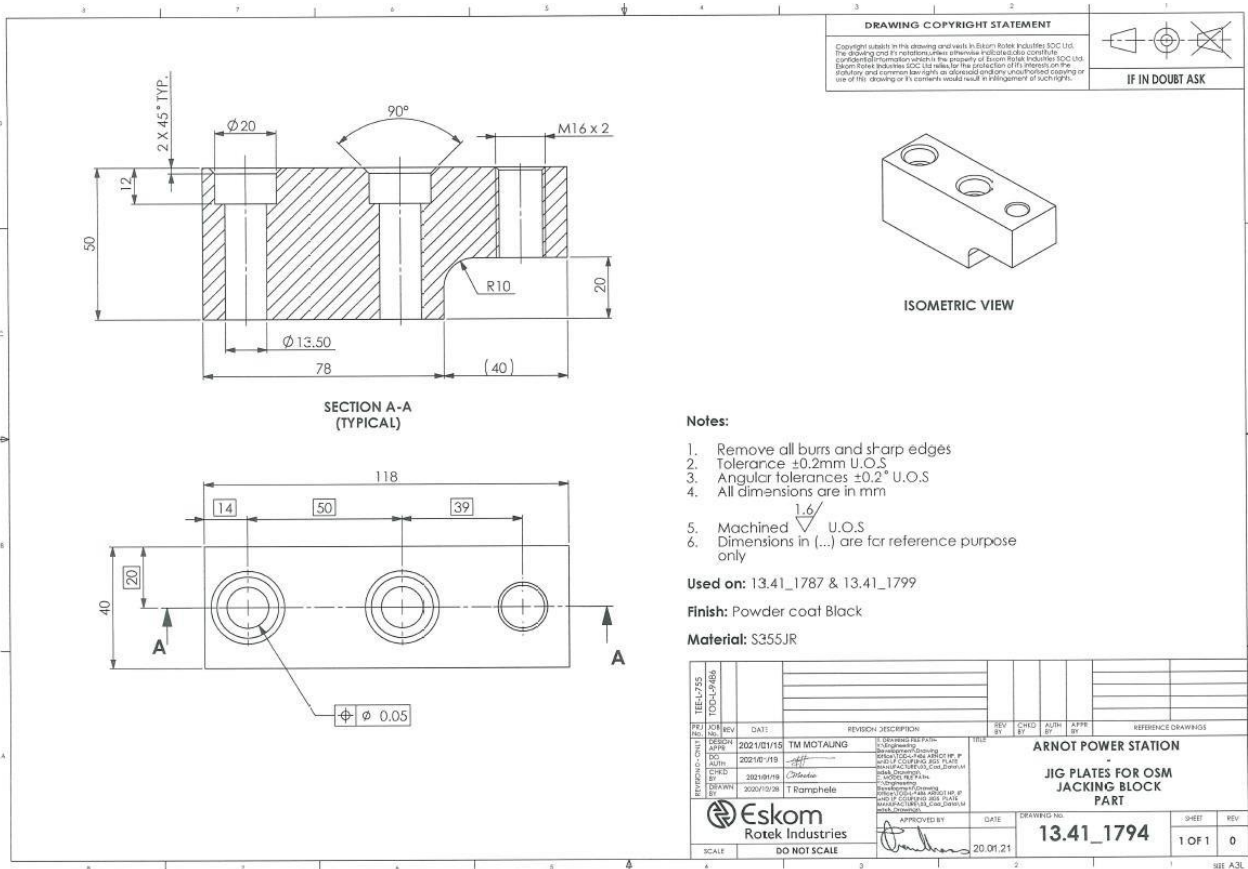

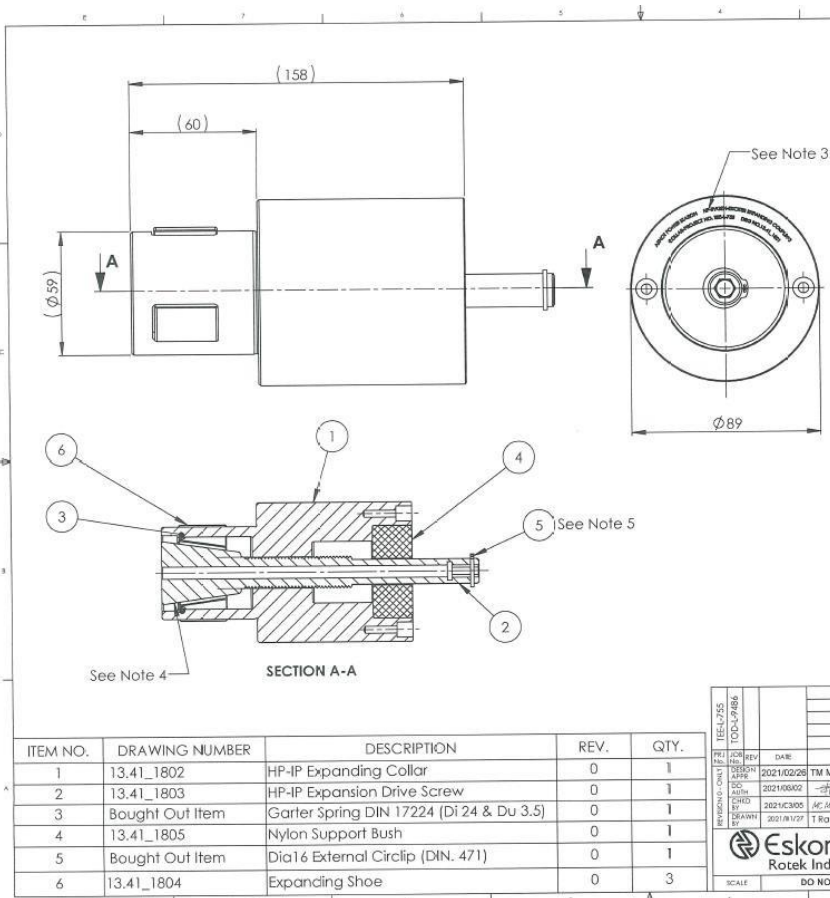

**DRAWING COPYRIGHT STATEMENT**  
 Copyright subsists in this drawing and vests in Eskom Rotek Industries SOC Ltd. The drawing and its contents, unless otherwise indicated, are confidential information which is the property of Eskom Rotek Industries SOC Ltd. Eskom Rotek Industries SOC Ltd reserves the protection of its interests in the drawing and its contents, and reserves all rights in, and all other intellectual property rights in, the drawing or its contents, and any unauthorised copying or use of the drawing or its contents would result in infringement of such rights.

IF IN DOUBT ASK

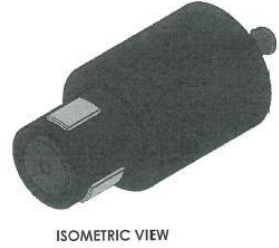

- Notes**
1. All dimensions are in mm
  2. All dimensions in (...) are for information only
  3. Stamp at this position "ARNOT POWER STATION HP-IP EXPANDING COUPLING COLLAR PROJECT NO.: TEE-L-755 DRAWING NO.: 13.41\_1801"
  4. Spray face with Molybdenum Disulfide (MoS<sub>2</sub>)
  5. Item 5 to be pressed in housing
- Used on : 13.41\_1797

| ITEM NO. | DRAWING NUMBER  | DESCRIPTION                              | REV. | QTY. |
|----------|-----------------|--|------|------|
| 1        | 13.41_1802      | HP-IP Expanding Collar                   | 0    | 1    |
| 2        | 13.41_1803      | HP-IP Expansion Drive Screw              | 0    | 1    |
| 3        | Bought Out Item | Garter Spring DIN 17224 (Di 24 & Du 3.5) | 0    | 1    |
| 4        | 13.41_1805      | Nylon Support Bush                       | 0    | 1    |
| 5        | Bought Out Item | Dia 16 External Circlip (DIN. 471)       | 0    | 1    |
| 6        | 13.41_1804      | Expanding Shoe                           | 0    | 3    |

| REV | DATE       | REVISION DESCRIPTION | REV | CHKD | APPR | APPR | REFERENCE DRAWINGS              |
|-----|------------|----------------------|-----|------|------|------|---------------------------------|
| 1   | 2021/03/28 | TM Motung            |     |      |      |      | ARNOT POWER STATION             |
| 2   | 2021/06/02 |                      |     |      |      |      | JIG PLATES FOR OSM              |
| 3   | 2021/06/02 |                      |     |      |      |      | HP-IP EXPANDING COUPLING COLLAR |
| 4   | 2021/06/02 |                      |     |      |      |      | ASSEMBLY                        |
| 5   | 2021/07/27 | T Ramphela           |     |      |      |      |                                 |

APPROVED BY: [Signature] DATE: 08.03.21 DRAWING NO.: 13.41\_1801 SHEET: 1 OF 1 REV: 0

SCALE: DO NOT SCALE

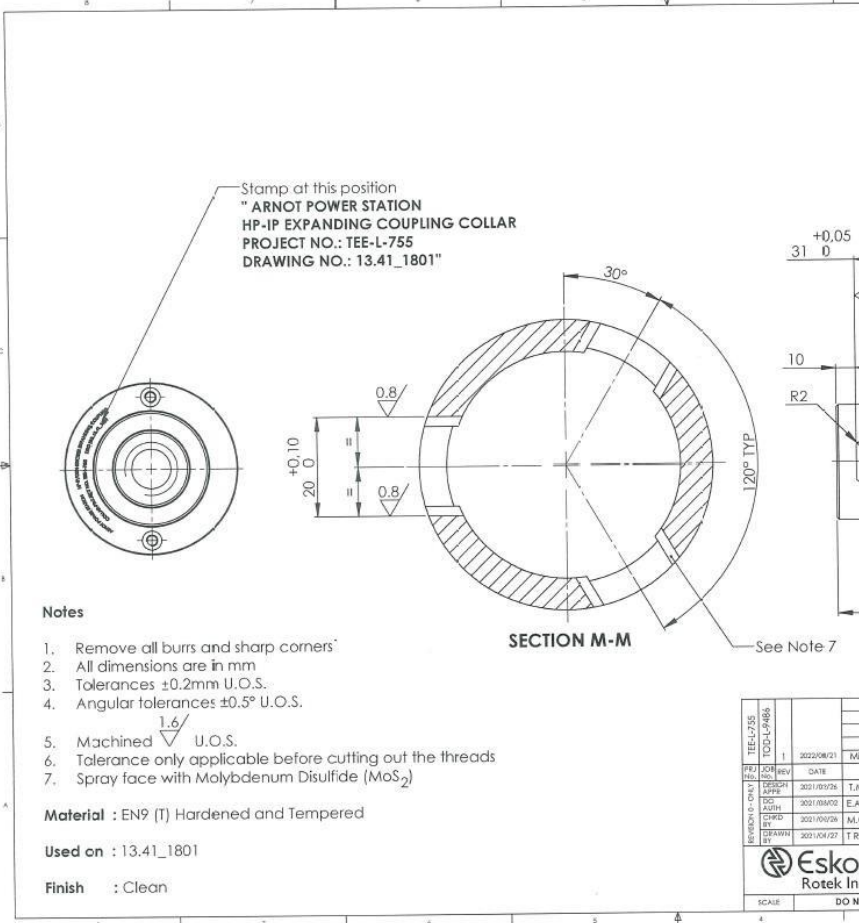

**DRAWING COPYRIGHT STATEMENT**  
 Copyright subsists in this drawing and vests in Eskom Rotek Industries SOC Ltd. The drawing and its contents, unless otherwise indicated, are confidential information which is the property of Eskom Rotek Industries SOC Ltd. Eskom Rotek Industries SOC Ltd reserves the protection of its interests in the drawing and its contents, and reserves all rights in, and all other intellectual property rights in, the drawing or its contents, and any unauthorised copying or use of the drawing or its contents would result in infringement of such rights.

IF IN DOUBT ASK

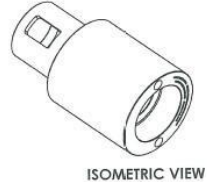

- Notes**
1. Remove all burrs and sharp corners
  2. All dimensions are in mm
  3. Tolerances  $\pm 0.2$ mm U.O.S.
  4. Angular tolerances  $\pm 0.5^\circ$  U.O.S.
  5. Machined  $\sqrt{1.6}$  U.O.S.
  6. Tolerance only applicable before cutting out the threads
  7. Spray face with Molybdenum Disulfide (MoS<sub>2</sub>)

**Material** : EN9 (T) Hardened and Tempered  
**Used on** : 13.41\_1801  
**Finish** : Clean

| REV | DATE       | REVISION DESCRIPTION             | REV | CHKD | APPR | APPR | REFERENCE DRAWINGS     |
|-----|------------|----------------------------------|-----|------|------|------|------------------------|
| 1   | 2022/06/21 | Missing dimension has been added |     |      |      |      | ARNOT POWER STATION    |
| 2   | 2021/09/24 | T.M Motung                       |     |      |      |      | JIG PLATES FOR OSM     |
| 3   | 2021/08/02 | E.A Mamma                        |     |      |      |      | HP-IP EXPANDING COLLAR |
| 4   | 2021/07/28 | M.C Moshia                       |     |      |      |      | PART                   |
| 5   | 2021/04/27 | T Ramphela                       |     |      |      |      |                        |

APPROVED BY: [Signature] DATE: 08.03.21 DRAWING NO.: 13.41\_1802 SHEET: 1 OF 2 REV: 1

SCALE: DO NOT SCALE

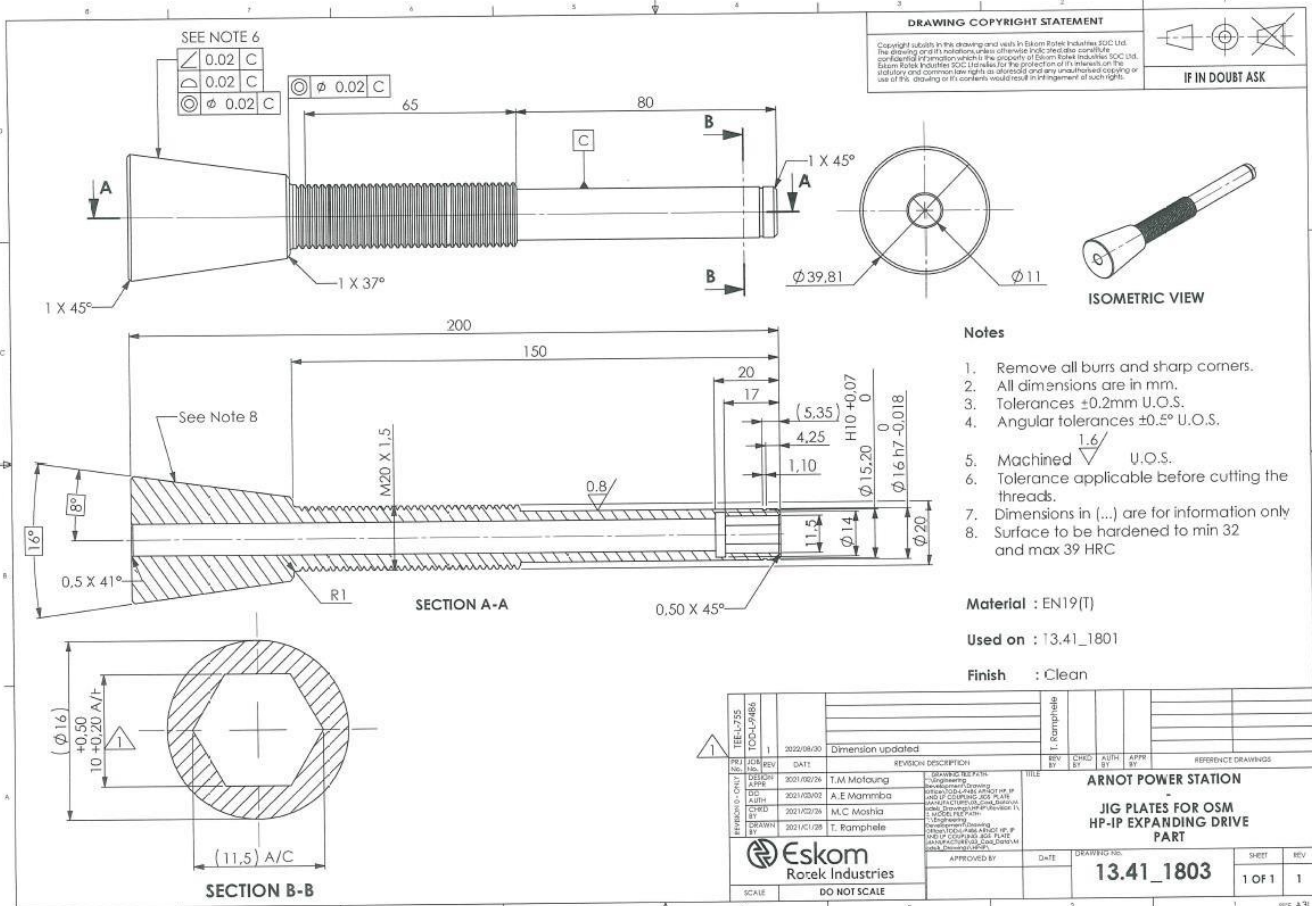
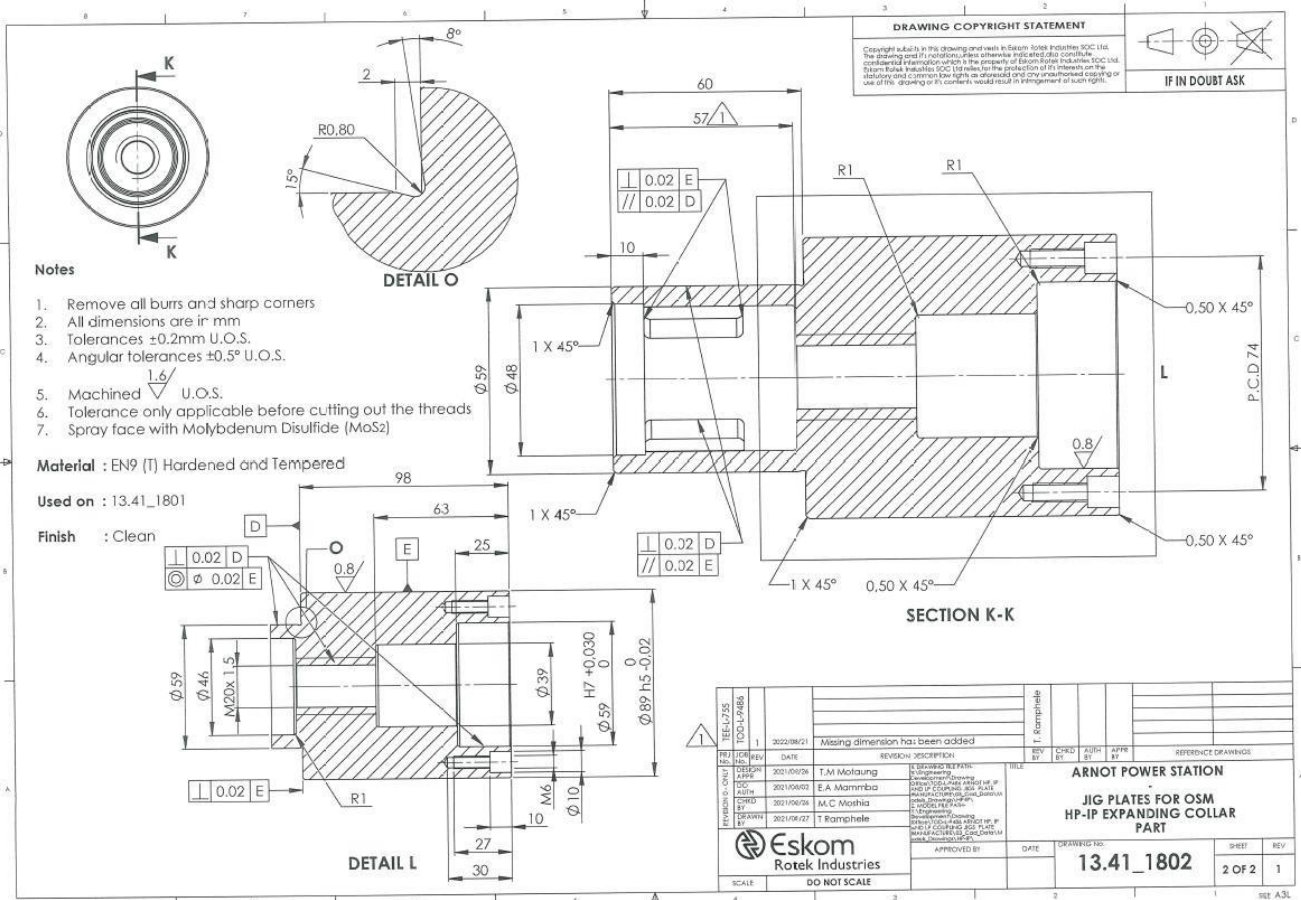

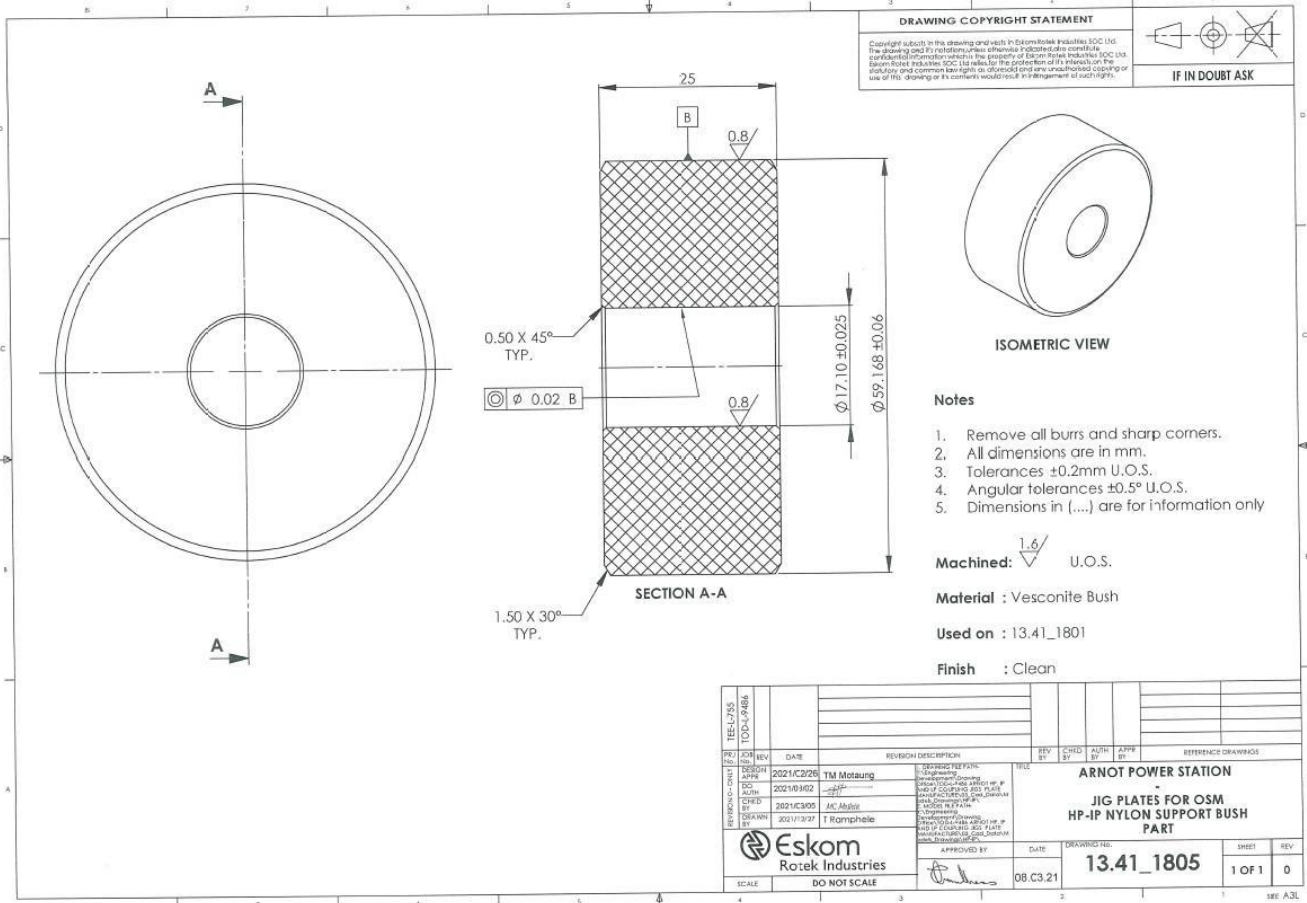
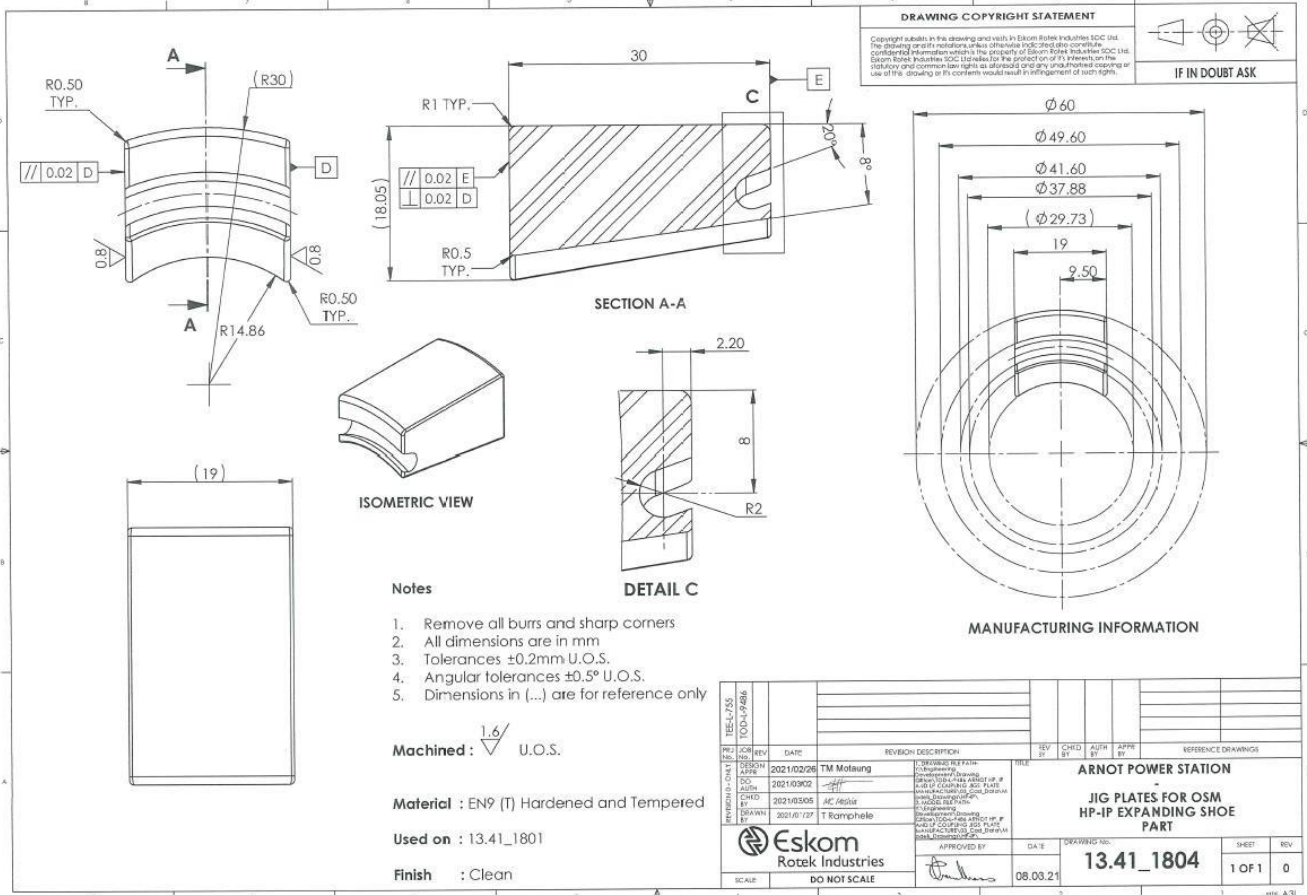

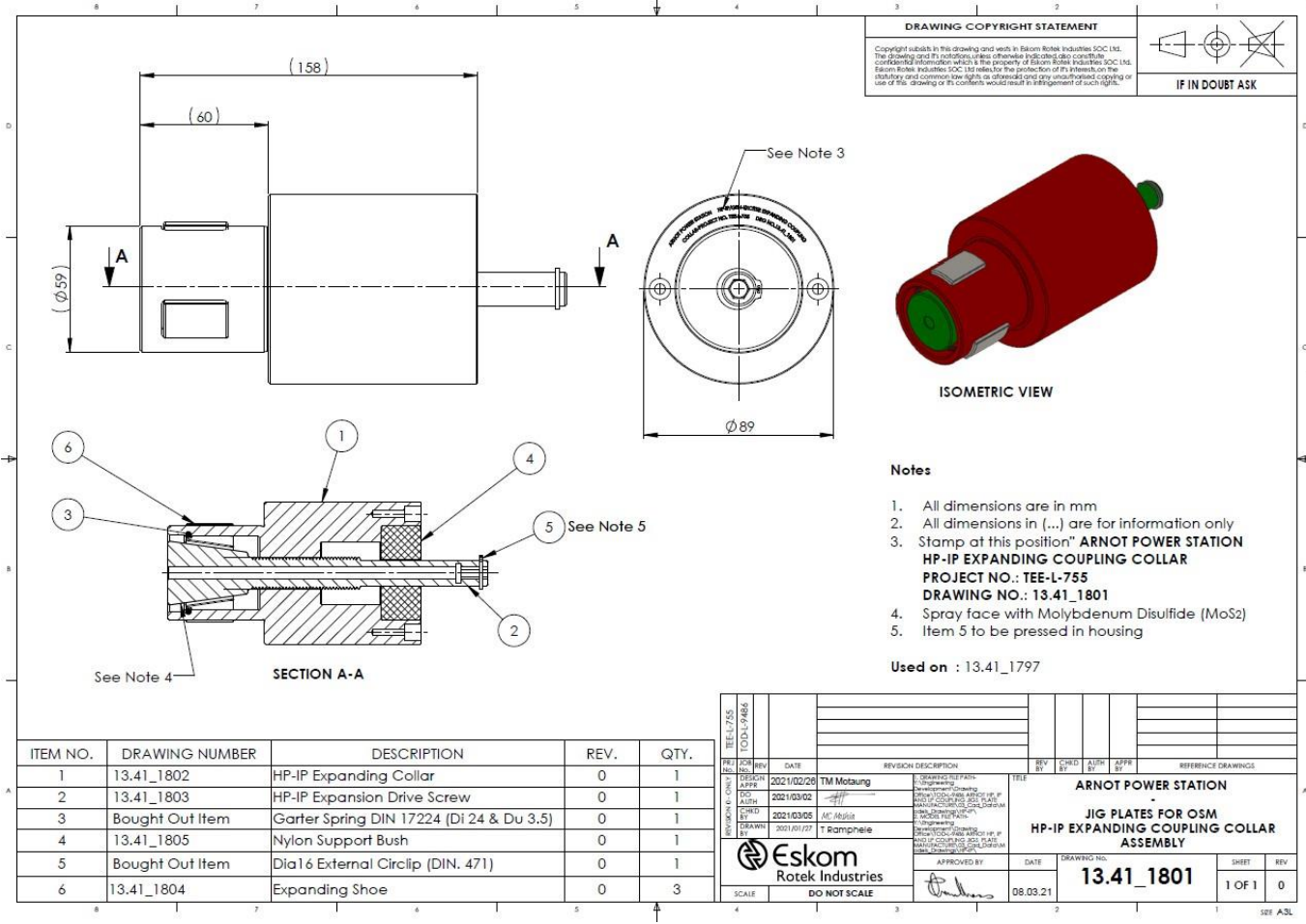

### 1.1 Purchaser's design

Clause 21.1 requires that the *Purchaser* states which parts of the *goods* he is to design. Complete as required or delete. Be careful not to duplicate what may already be covered in the *Purchaser's* operating philosophy / user requirement specification (URS) / performance specification described elsewhere in this Goods Information.

### 1.2 Procedure for submission and acceptance of Supplier's design

This is a mandatory requirement of core clause 21.2 and must be addressed. Identify the extent of detail (the particulars) of the *Supplier's* design which is to be submitted to the *Supply Manager* for his acceptance. State requirements for drawings to be prepared by the *Supplier*.

### 1.3 Other requirements of the Supplier's design

Use this section to describe any particulars which must be taken into account by the *Supplier* in his design; for example codification of the *goods*.

## 1.4 Use of *Supplier's* design

First read core clause 22.1 and then include here the exceptions and other purposes if applicable. If there are none this section could be deleted leaving the core clause to stand.

## 1.5 Manufacture & fabrication

Although the *Purchaser* does not usually prescribe how the *goods* are to be manufactured and fabricated, if there are any specific requirements they could be stated here.

## 1.6 Factory acceptance testing (FAT)

Core Clauses 40 and 41 both make reference to the Goods Information regarding tests and inspections. There are often comprehensive requirements for testing at place of manufacture and before delivery. State whether the tests are to be witnessed by the *Supply Manager* or by a testing agency of the *Purchaser's* nomination. Note, *Supplier* may not restrict *Supply Manager's* right to witness tests per clause 25.2

## 1.7 Other tests and inspections and commissioning in place of use

Describe any other tests and inspections that may be required, specifically in the place of use. If the *Supplier* is to commission the *goods* in the place of use after Delivery, describe the process here. If he is only required to witness and report on the commissioning done by others, this would be included as a service in section 4 below.

## 1.8 Operating manuals and maintenance schedules

Use this section to describe these requirements. Pay particular attention to when and in what form they are required. Consideration should be given to obtaining operating manuals and maintenance schedules before Delivery of the whole of the *goods* when there is still financial incentive for the *Supplier* to do so.

## 2 Supply Requirements

Clause 11.2(16) defines Supply Requirements and clause 11.2(8) states that they are part of the Goods Information. They can either be included here or as an Annexure to the Contract Data provided by the *Purchaser* because of their commercial nature. Eskom has chosen to include them in the C1.2a Contract Data, hence include the following text here:

The Supply Requirements for this contract are in an Annexure to the Contract Data provided by the *Purchaser*.

### **3 Specification of the *services* to be provided**

These services may include training of the *Purchaser's* staff in the use of the *goods*, supervision of installation of the *goods* on the *Purchaser's* property and post Delivery commissioning and monitoring of the *goods* in use. Ensure that all items of service specified can be related to an item in the Price Schedule

### **4 Constraints on how the *Supplier* Provides the Goods**

#### **4.1 Programming constraints**

Read clause 31.2 first then state what additional information (if any) is to go in the programme per the last bullet of clause 31.2. Describe any particular constraints on the order and timing of the work which the *Supplier* must take into account in his programme.

#### **4.2 Work to be done by the Delivery Date**

Clause 11.2(5) defines Delivery as when the *Supplier* has done all the work which the Goods Information states he is to do by the Delivery Date. The defined term "Delivery" is used in this contract to identify when a stage, or amount of work has been achieved. This may be more than the common meaning of "delivery" and could include the passing of specified tests, provision of documentation and packing and preparation for air freight or shipping to the *Purchaser's* nominated Delivery Place specified in the Supply Requirements.

Either list here what has to be done in order to constitute "Delivery", or list what may remain undone and be completed after the Delivery Date by stating that everything else must be done before Delivery.

#### **4.3 Marking the *goods***

If this contract requires the *goods* be paid for before they are brought within the Delivery Place, core clause 71.1 requires that the Goods Information state how the *Supplier* is to "mark" the *goods*

#### **4.4 Constraints at the delivery place and place of use**

State any constraints on how the *Supplier* is to provide the *goods* and *services* both at the delivery place and where the *goods* and *services* are to be put into use, e. g. restriction on access, hours of working and sequence of work. Sites such as Sasol Secunda and Koeberg Nuclear Power Station have very strict entrance requirements which tenderers need to allow for in their prices, and the *Supplier* has to comply with. State these or similar requirements here.

#### **4.5 Cooperating with Others**

Although not a direct requirement of the *conditions of contract* if the *Purchaser* is aware of the *Supplier's* need to co-operate with Others (for example where the supply is to one of the *Purchaser's* contractor's on a project or design of the *goods* needs to be discussed with Others) details could be given here.

#### 4.6 Services & other things to be provided by the *Purchaser* or *Supplier*

Clause 23.2 requires that the Goods Information state what services and other things are to be provided by the Parties, each to the other as part of the supply process. This has nothing to do with the *services* identified in the Contract Data. It would include temporary services and things needed to facilitate the supply, such as cranes provided by the *Purchaser* for offloading of the *goods*.

#### 4.7 Management meetings

The *conditions of contract* (e.g. Clause 16.2) require and other sections of the Goods Information (e.g. safety risk management) may require (mandate) that a meeting shall be held. However the intention of all NEC contracts is that the Parties and their agents use the techniques of partnering to manage the contract by holding meetings designed to pro actively and jointly manage the administration of the contract with the objective of minimising the adverse effects of risks and surprises for both Parties.

Depending on the complexity of the *goods*, it is probably beneficial for the *Supply Manager* to hold a regular risk register meeting (Clause 16.2). This could be used to discuss safety, compensation events, subcontracting, overall co-ordination and other matters of a general nature. Separate meetings for specialist activities such as programming, engineering and design management, may also be warranted.

Describe here the general meetings and their purpose. Provide particulars of approximate times, days, location, and attendance requirements, stipulating that attendees shall have the necessary delegated authority to make decisions in respect of matters raised at such meetings.

The right to hold specialist meetings should be stated generically and in such a way that ambiguity with other parts of the Goods Information is avoided.

The following text could be used as a model for this section:

Regular meetings of a general nature may be convened and chaired by the *Supply Manager* as follows:

| Title and purpose                      | Approximate time & interval | Location | Attendance by:                        |
|--|-----------------------------|----------|---------------------------------------|
| Risk register and compensation events  | Weekly on _____ at _____    |          |                                       |
| Overall contract progress and feedback | Monthly on _____ at _____   |          | <i>Purchaser, Supplier, and _____</i> |
|  |                             |          |                                       |
|  |                             |          |                                       |

Meetings of a specialist nature may be convened as specified elsewhere in this Goods Information or if not so specified by persons and at times and locations to suit the Parties, the nature and the progress of the manufacture of the *goods*. Records of these meetings shall be submitted to the *Supply Manager* by the person convening the meeting within five days of the meeting.

All meetings shall be recorded using minutes or a register prepared and circulated by the person who convened the meeting. Such minutes or register shall not be used for the purpose of confirming actions or instructions under the contract as these shall be done separately by the person identified in the *conditions of contract* to carry out such actions or instructions.

#### 4.8 Documentation control

Specify how documentation will be identified with an alpha numeric which indicates source, recipient, communication number etc. Provide details of any particular format or other constraints; for example that all contractual communications will be in the form of properly compiled letters or forms attached to e mails and not as a message in the e mail itself. State any particular routing requirements but note from SC who issues what to whom.

#### **4.9 Health and safety risk management**

In addition to the requirements of the laws governing health and safety, the *Purchaser* may have some additional requirements particular to the *goods* and the location where they are to be delivered for this contract. This is a requirement of clause 25.4.

The *Supplier* shall comply with the health and safety requirements [stated here or contained in Annexure \_\_\_\_\_ to this Goods Information].

#### **4.10 Environmental constraints and management**

Describe or cross refer to environmental constraints applicable to the *Supplier's* design of the *goods* if not already included in the *Purchaser's* URS.

The *Supplier* shall comply with the environmental criteria and constraints [stated here or contained in Annexure \_\_\_\_\_ ]

#### **4.11 Quality**

Specify minimum requirements for the *Supplier's* Quality Plan and Work Procedures if required and not already covered in the specifications for the *goods*. State whether ISO compliance is a condition and if so which ISO standard shall apply.

#### **4.12 Invoicing and payment**

List the information that is to be shown by the *Supplier* on his invoices. State any other requirements relating to payment. For example:

Within one week of receiving a payment certificate from the *Supply Manager* in terms of core clause 51.1, the *Supplier* provides the *Purchaser* with a tax invoice showing the amount due for payment equal to that stated in the *Supply Manager's* certificate.

The *Supplier* shall address the tax invoice to *Purchaser* and include on each invoice the following information:

- Name and address of the *Supplier* and the *Supply Manager*;
- The contract number and title;
- *Supplier's* VAT registration number;
- The *Purchaser's* VAT registration number.
- Description of *goods* and *services* provided for each item invoiced based on the Price Schedule;
- Total amount invoiced excluding VAT, the VAT and the invoiced amount including VAT;
- (add other as required)

Add procedures for invoice submission and payment (e. g. electronic payment instructions)

#### **4.13 Insurance provided by the *Purchaser***

First read SC3 Core Clause 84.1 and then add anything necessary for the management of insurance related issues such as a cross reference to where procedures for making claims can be found. Also provide contact details for persons capable of being able to answer any insurance related queries the *Supplier* may have, as well as to whom the information required by any Marine Insurance may be addressed.

#### **4.14 Contract change management**

This section is intended to deal with any additional requirements to the compensation event clauses in section 6 of the core clauses; such as the use of standard forms. Not the same thing as documentation control.

#### **4.15 Provision of bonds and guarantees**

The form in which a bond or guarantee required by the *conditions of contract* (if any) is to be provided by the *Supplier* is given in Part 1 Agreements and Contract Data, document C1.3, Sureties.

The *Purchaser* may withhold payment of amounts due to the *Supplier* until the bond or guarantee required in terms of this contract has been received and accepted by the person notified to the *Supplier* by the *Supply Manager* to receive and accept such bond or guarantee. Such withholding of payment due to the *Supplier* does not affect the *Purchaser's* right to termination stated in this contract.

#### **4.16 Records of Defined Cost, payments & assessments of compensation events to be kept by the Supplier**

Read clause 63.2 and 11.2(4) and then state whether the *Supplier* is required to keep any records of Defined Cost. Include any other constraint which may be required in regard to format and filing of the records, and whether access for the *Supply Manager* shall be provided in hard copy or electronically.

### **5 Procurement**

#### **5.1 Subcontracting**

##### **5.1.1 Preferred subcontractors**

SC does not make use of nominated subcontracting, but the *Purchaser* may list which subcontractors or sub-suppliers the *Supplier* is required to enter into subcontracts with (if any). This is usually only required where plant and materials need to be obtained from a particular supplier or group of suppliers in order to comply with operational standards for the *goods*.

##### **5.1.2 Limitations on subcontracting**

The *Purchaser* may require that the *Supplier* must subcontract certain specialised work, or that the *Supplier* shall not subcontract more than a specified proportion of the whole of the contract.

##### **5.1.3 Spares and consumables**

Some contracts may need to include provision for the supply of a minimum category of spares, fuel, oil or other consumables which the *Purchaser* may need at or just after delivery or commissioning of the *goods* and that it is best the *Supplier* provide these initially as part of his Providing the Goods and Services

**5.1.4 Other requirements related to procurement**

Other requirements such as ASGISA or socio political enhancements the *Supplier* is to provide as part of Providing the Goods and Services (if any) could be included here.

**6 List of drawings**

**6.1 Drawings issued by the *Purchaser***

This is the list of drawings issued by the *Purchaser* at or before the Contract Date and which apply to this contract.

| Drawing number | Revision | Title |
|----------------|----------|-------|
|                |          |       |
|                |          |       |
|                |          |       |
|                |          |       |
|                |          |       |
|                |          |       |

## C3.2 SUPPLIER'S GOODS INFORMATION

This section of the Goods Information will always be contract specific depending on the nature of the *goods* and *services*.

It is most likely to be required for supply contracts where the tendering supplier will have proposed specifications and schedules for the *goods* and *services*, which once accepted by the *Purchaser* prior to award of contract now become obligations of the *Supplier* per core clause 20.1.

This section could also be compiled as a separate file.

---

## CONFIDENTIALITY AGREEMENT

This Confidentiality Agreement ('Agreement') is entered into between the Purchaser and the Supplier.

WHEREAS, the Purchaser and the Supplier (the Parties) desire to exchange certain confidential information; and consider further business dealings with each other.

WHEREAS, the parties desire to evidence their agreements governing the exchange of certain confidential information as set forth below.

Now therefore, for good and valuable consideration, including the mutual agreements hereinafter recited, the parties hereby agree as follows:

1. The parties contemplate an exchange, either orally, in writing or by inspection, of certain confidential proprietary information possessed or owned separately by them and not readily available or otherwise known to the public and which may be helpful in evaluating further business dealings. Such confidential information (the 'Subject Information') may include but not be limited to the parties' inventions, trade secrets, know-how, technical information on products and manufacturing processes, and information concerning their business assets, financial condition, operations, plans and prospects.
2. The purpose of the exchange of Subject Information is to enable the parties to evaluate the Subject information for the purpose only of considering further business dealings with each other.
3. The parties each agree that they shall maintain in secrecy in accordance with the terms of this Agreement all of the Subject Information each party receives (the 'Receiving Party') from the other party (the 'Proprietor') and shall not disclose or use other than for the purpose specified herein the Subject Information without the written consent of the Proprietor of the Subject Information. All Subject Information communicated from one party to the other shall be deemed to be proprietary and confidential to the Proprietor whether marked or identified as such or not.
4. The duty of care to safeguard Subject Information shall be the same as that which the parties each use to safeguard their own respective proprietary and confidential information.
5. The Receiving Party of Subject Information shall not be obligated to maintain Subject Information received from its Proprietor in secrecy or refrain from using it to the extent that any such information is or rightfully becomes publicly available information other than through a breach of this Agreement, or which the Receiving Party later obtains lawfully from anyone else who is not known by the Receiving Party to be obligated under any secrecy agreement with Proprietor to maintain the information in secrecy. The Receiving Party also shall not be obligated to maintain in secrecy any information it receives from the Proprietor which it can demonstrate was already in its possession when the information was disclosed to the Receiving Party by the Proprietor.
6. The Receiving Party shall promptly return to its Proprietor any Subject Information in tangible form it has received from the Proprietor immediately upon the Proprietor's request, without retaining any copies, summaries, analyses or extracts thereof. All documents, memoranda, notes and other writings prepared by the parties, or their advisors, based on the Subject Information of each other, shall be destroyed, and such destruction shall be certified in writing by an authorised officer supervising such destruction.
7. If a party, with the written consent of the Proprietor of Subject Information, discloses any Subject Information received from its Proprietor to any third party, it shall do so only under a secrecy agreement having a scope similar to and which is consistent with this Agreement, and

the disclosing party shall be primarily responsible for any compromise of the secrecy of Subject Information by such third party

8. Each party agrees that it shall not, while and for so long as it is obligated to maintain Subject Information in secrecy, use for its own benefit, or for the benefit of others or exploit, commercialise, develop, test promote, sell, lease, market or otherwise dispose of any products or services using, incorporating or relying on Subject Information received from its Proprietor without the written consent of the Proprietor.
9. The obligations of the party receiving Subject Information pursuant to this Agreement shall be effective with respect of each item of Subject Information for a term of five (5) years from the date of submission of the Subject Information to the Receiving Party by its Proprietor, unless the Proprietor agrees otherwise in writing.
10. For purposes of this Agreement, each party shall include (to the extent applicable) the officers, directors, employees, agents, representatives, attorneys, joint ventures, partnerships, affiliates, subsidiaries, and divisions of the party, and any other entity or entities which such party controls or which controls it, and, further, shall include any transferee, successor and assign of the assets of the party.
11. This Agreement shall be construed (both as to validity and performance) and enforced in accordance with, and governed by, the laws of Republic of South Africa.
12. Neither this Agreement nor the exchange of Subject Information between the parties shall create or be relied on by either party as a basis for creating any license between the parties under any patent, or other industrial or intellectual property rights of the Proprietor of the Subject Information, or any other license between the parties in the absence of any express written license agreement between them
13. The parties agree that no contract or agreement providing for a transaction shall be deemed to exist between them unless and until a definitive agreement has been executed and delivered, the parties hereby waive, in advance, any claim (including, without limitation, breach of contract) in connection with a possible transaction with each other unless and until they shall have entered into a definitive agreement. The parties also agree that unless and until a definitive agreement between them has been executed and delivered, neither party has any legal obligation of any kind whatsoever with respect to any such transaction by virtue of this Agreement or any other written or oral expression with respect to such transaction, except, in the case of this Agreement, for the matters specifically agreed to herein. For purposes of this paragraph, the term 'definitive agreement'; does not include an executed letter of intent, memorandum of understanding.

IN WITNESS WHEREOF, and intending to be legally bound, this Agreement has been executed by the parties as of and effective from the date first written above.