

	SPECIFICATION	GROOTVLEI POWER STATION
---	----------------------	--------------------------------

Title: **High Risk Specification for Coal Station**

Document Identifier: **GVL/0650**

Alternative Reference Number: **N/A**

Area of Applicability: **Grootvlei Power Station**

Functional Area: **Risk and Assurance**

Revision: **1**

Total Pages: **40**

Next Review Date: **As required**

Disclosure Classification: **Controlled Disclosure**

Project Name: The provision of scheduled maintenance and breakdown attendance for Fire Detection System including spares supply at Grootvlei Power Station and Vaal Dam pumping Station Site for a period of 60 months.

File name: [GVL 0650 High Risk Specification - Maintenance of Fire Detection System](#)

Template ID: 32-4 (Rev 13) Document template (for procedures, manuals, standards, instructions, etc.

Formatted by: EDC_Risk and Sustainability 13.03..24/EDC TR Formatted 03.06.2024

Contents

2. SUPPORTING CLAUSES 5

2.1 SCOPE 5

 2.1.1 Purpose 5

 2.1.2 Applicability 5

2.2 NORMATIVE/INFORMATIVE REFERENCES 5

 2.2.1 Normative 5

 2.2.2 Informative 6

2.3 DEFINITIONS 6

2.4 ABBREVIATIONS 10

2.5 RELATED/SUPPORTING DOCUMENTS 10

3. DOCUMENT CONTENT 11

3.1 SCOPE OF WORK 11

THE DETAILED SCOPE OF WORK FOR THIS PROJECT MUST BE LISTED HERE 11

3.2 LEGAL COMPLIANCE 15

 3.2.1 Section 37(2) (Legal) Agreement 15

 3.2.2 Hazardous Work by Children (Child Labour) 15

 3.2.3 OHS Act 15

 3.2.4 Legislative Compliance 15

3.3 ESKOM REQUIREMENTS 16

3.4 SHEQ POLICY 16

3.5 COVID -19 POLICY 16

 3.5.1 Covid -19 requirements 16

3.6 COID 16

3.7 COSTING FOR OHS WITHIN THE PROJECT 17

3.8 STATUTORY APPOINTMENTS 17

 3.8.1 Non statutory appointments 17

3.9 ESKOM LIFE-SAVING RULES 18

3.10 SUBSTANCE ABUSE 19

3.11 CONTRACTOR ORGANISATIONAL STRUCTURE 19

 3.11.1 Main Contractor Organogram 19

 3.11.2 Appointed Contractor/s Organogram 19

3.12 ROLES AND RESPONSIBILITIES 20

Commitment 20

 3.12.1 Main contractors and appointed contractors 20

 3.12.2 Contractor site supervisor 21

 The contractor site supervisor must be trained in the following 21

 • HIRA, Incident investigation training, Supervisor training, authorised person & PSR, Legal liability 21

 3.12.3 Contractor Health and Safety officer 22

 • Please state if you require full time or part time Safety Officer for this contract if any safety officer is required 22

 The contractor health and Safety officer must be trained in the following 22

 • SAMTRAC, HIRA, Incident investigation training, Legal liability, Training, knowledge and

CONTROLLED DISCLOSURE

When downloaded from the document management system, this document is uncontrolled and the responsibility rests with the user to ensure it is in line with the authorised version on the system.

No part of this document may be reproduced without the expressed consent of the copyright holder, Eskom Holdings SOC Limited, Reg No 2002/015527/30.

understanding of ISO 4500, Minimum work experience 2yrs, OHS Diploma (applicable to 3-5 years contract).....	22
3.13 RISK ASSESSMENT (REFER TO 32-520).....	22
3.14 SAFE WORK PROCEDURES / METHOD STATEMENTS.....	23
3.15 ROOF WORK (REFER TO 32- 418).....	24
3.16 FIRE EQUIPMENT AND MAINTENANCE.....	24
3.17 FLAMMABLE AND COMBUSTIBLE LIQUIDS.....	24
3.17.1 Refuelling at Eskom sites.....	25
3.18 FIRST AID AND EQUIPMENT.....	25
3.18.1 Boxes and equipment.....	26
3.19 OHS COMMUNICATION SYSTEMS.....	26
3.19.1 Statutory Health and Safety Committees.....	26
3.19.2 Non-statutory health and safety committees.....	27
3.20 TOOL BOX TALKS / DAILY TEAM TALKS / PRE JOB MEETINGS.....	28
3.21 OHS TRAINING.....	29
3.21.1 Main Contractor Induction training.....	29
The contractor is required to make arrangements with the Business Unit for its employees to attend induction in order to be granted permission to access site.....	29
3.21.2 Appointed Contractor induction training.....	29
3.21.3 Visitors to site induction.....	30
3.22 GENERAL TRAINING.....	30
3.23 CONTRACTOR SITE ESTABLISHMENT.....	30
WHERE CONTRACTORS ARE PROVIDING THEIR OWN FACILITIES, THE FOLLOWING SHALL APPLY.....	30
WHERE ESKOM IS MAKING PROVISION OF THE FACILITIES TO THE CONTRACTOR, THE FOLLOWING SHALL APPLY.....	30
3.24 SITE ROADS.....	31
3.25 VEHICLE MANAGEMENT.....	31
3.26 HOUSEKEEPING AND ORDER.....	32
3.27 STACKING AND STORAGE.....	32
3.28 WORKPLACE SIGNAGE AND COLOUR CODING.....	33
3.29 TOOLS AND EQUIPMENT.....	33
3.29.1 Hand tools.....	34
3.30 LADDERS.....	34
3.31 SCAFFOLDING.....	35
3.32 AUDITING.....	35
3.32.1 Approval and compliance of Main contractor OHS plan.....	35
3.32.2 Eskom OHS audits.....	35
3.32.3 Contractor audits.....	36
3.33 SMOKING.....	36
3.34 CELLULAR PHONES.....	36
3.35 OCCUPATIONAL HEALTH, HYGIENE AND REHABILITATION.....	36
3.35.1 Occupational Hygiene Hazards Identification and Risk Assessment Report (HIRA).....	37
3.35.2 Occupational Hygiene Monitoring Noise.....	37
3.35.3 Hazardous Chemical Agents (Fly Ash, Respirable Dust and Respirable Crystalline Silica).....	37
3.35.4 Ergonomic Risk Assessment.....	38
3.35.5 Medical Surveillance.....	38
3.35.5 information and Training.....	39
3.36 ROLES AND RESPONSIBILITIES.....	39
3.37 WORKING AT HEIGHTS.....	39

CONTROLLED DISCLOSURE

When downloaded from the document management system, this document is uncontrolled and the responsibility rests with the user to ensure it is in line with the authorised version on the system.

No part of this document may be reproduced without the expressed consent of the copyright holder, Eskom Holdings SOC Limited, Reg No 2002/015527/30.

3.37.1 General Requirements	39
Wherever reasonably practicable, preference is given to the performance of work at ground level as opposed to the elevated position. Where work in an elevated position is necessary, preference is given to fall prevention measures such as, but not limited to, effective barricading and the use of work platforms. Persons may only work from a fall risk position if a site-specific fall protection plan developed by the appointed competent person (as per 32-418 procedure) is in place and correctly implemented and consists of the following	39
While work is in progress, adequate warning signs and/or barricades shall be used in all areas where there is a risk of persons being injured by materials or equipment falling from the work area. Barricades should be continuous and easily visible.	40
A drop zone shall be established with appropriate warning signs and barricading, warning personnel below of workers above and potential falling objects	40
Every employer shall ensure that work at height is.....	40
3.38 CONFINED SPACES	40
3.39 PERSONAL PROTECTIVE EQUIPMENT REQUIREMENTS.....	41
3.40 INCIDENT INVESTIGATION	41
3.41 EMERGENCY MANAGEMENT.....	42
3.42 NON-CONFORMANCE AND COMPLIANCE	42
3.43 OHS FILES.....	42
3.44 WORK STOPPAGE.....	43
3.45 HOURS OF WORK	43
3.45.1 Normal work	43
3.45.2 Night work.....	43
3.45.3 Overtime.....	43
3.46 OMISSIONS FROM SAFETY AND HEALTH REQUIREMENTS SPECIFICATION	44
3.47 BARRICADING.....	44
3.47 CONTRACTOR PERFORMANCE MONITORING	47
3.48 CONTRACT SIGN OFF.....	47
3.49 ESKOM'S RIGHT TO TERMINATE THE CONTRACT	47
4. AUTHORIZATION	47
5. REVISIONS	48
6. DEVELOPMENT TEAM	48

1. Introduction

Eskom’s responsibility and commitment is to ensure a safe working environment is in line with its Safety, Health, Environmental, and Quality (SHEQ) Policy and applicable legislative obligations. This OHS specification is Eskom Generation's minimum requirements which are required to be met for the duration of the contract period by contractors/suppliers and, where required, the delivery organisation. The contractor is expected to develop an OHS plan that meets these requirements as well as all the relevant applicable legislation that they conform to. Eskom in no way assumes the contractor’s legal responsibilities and liabilities. The contractor is and remains accountable for the quality and execution of their health and safety programme for their employees and appointed contractor employees. This OHS specification reflects minimum requirements and should not be construed as all-encompassing.

CONTROLLED DISCLOSURE

When downloaded from the document management system, this document is uncontrolled and the responsibility rests with the user to ensure it is in line with the authorised version on the system.

No part of this document may be reproduced without the expressed consent of the copyright holder, Eskom Holdings SOC Limited, Reg No 2002/015527/30.

Note 1: All the requirements listed hereunder are in relation to the contract and do not supersede or replace any organizational OHS requirements.

Where requirements listed are already in place, then the organizational requirements must be taken cognisance of and listed in the respective OHS plans. If there are any additional Eskom and/or legislative requirements listed in the OHS specification, then these must be addressed.

2. SUPPORTING CLAUSES

2.1 SCOPE

This OHS specification lists the legislative and Eskom requirements and, where applicable, any requirements pertaining to local authorities, municipal by-laws, or environmental legislation that must be met by the contractor.

2.1.1 Purpose

This document will provide a standardised approach to the compilation of OHS specifications throughout Eskom Generation business for contracts, standards, and NEC 3.

2.1.2 Applicability

This OHS specification is applicable to any contracting organisation that intends to respond to Eskom Generation's tender/enquiry with the intention of entering into a contract.

2.2 NORMATIVE/INFORMATIVE REFERENCES

Parties using this document shall apply the most recent edition of the documents listed in the following paragraphs.

2.2.1 Normative

- Basic Conditions of Employment Act No 75 of 1997.
- Occupational Health and Safety Act and Regulations No 85 of 1993.
- OHS Act "Regulations on Hazardous Work by Children in South Africa"
- National Environmental Management Act 107 of 1998.
- National Road Traffic Act 93 of 1996.
- 32-37 Eskom Substance Abuse Procedure.
- 32-136 Contractor Health and Safety Requirements
- 240-62196227 Life- saving Rules
- 32-95 Environmental, Occupational Health and Safety Incident Management Procedure
- 32-727 SHEQ Policy
- 32- 418 Working at Heights Procedure
- 240-62946386 Vehicle and Driver Safety Management Procedure
- 32-520 Risk Assessment procedure
- Plant Safety Regulations

CONTROLLED DISCLOSURE

When downloaded from the document management system, this document is uncontrolled and the responsibility rests with the user to ensure it is in line with the authorised version on the system.

No part of this document may be reproduced without the expressed consent of the copyright holder, Eskom Holdings SOC Limited, Reg No 2002/015527/30.

- ISO 45001
- Eskom Covid-19 policy
- National Disaster Management Act 57 of 2002

2.2.2 Informative

[1] Tobacco Products Control Act 83 of 1993 (Updated 2011.05.19)

[2] SANS 1186 Symbolic Safety Signs

[3] Constitution of the Republic of South Africa No 108 of 1996

[4] DMN 34-110 Operating A Vehicle Mounted Crane

2.3 DEFINITIONS

CONTROLLED DISCLOSURE

When downloaded from the document management system, this document is uncontrolled and the responsibility rests with the user to ensure it is in line with the authorised version on the system.

No part of this document may be reproduced without the expressed consent of the copyright holder, Eskom Holdings SOC Limited, Reg No 2002/015527/30.

Definition	Explanation
Appointed contractor	Means a contractor appointed by the Main contractor
Baseline risk assessment	(32-520) baseline operational risks refer to the health and safety risks associated with all standard processes and routine activities in the business
Business unit (BU)	(32-296) means any defined unit within the Eskom environment, operating as a business under a particular cost-centre number. In the context of this document and in terms of health and safety, any reference to a BU includes a defined unit within any Eskom division and its subsidiaries
Client	(OHS Act) Eskom representative (Internal – Asset Owner), also referred to as the contract administrator/custodian or agent or project manager (as defined in the contract). He/she is the person responsible for ensuring that the works or services are executed in terms of the contract, as well as adherence to legislation pertaining to the contract.
Competent person	(OHS Act) means any person having the knowledge, training, experience, and qualifications, specific to the work or task being performed, provided that, where appropriate, qualifications and training are registered in terms of the South African Qualifications Authority Act, 1995 (Act No. 58 of 1995)
Contractor	(OHS Act) means an employer as defined in section 1 of the Act who performs contracted work and includes Main contractors
Contract's Manager/End User	Contract's Manager/End User
Consultant	means a person providing professional advice
Controlled disclosure	controlled disclosure to external parties (either enforced by law or discretionary)
Duty of care to the environment	(32-136) anybody who causes or has caused or may cause significant pollution or degradation of the environment must take reasonable measures to prevent such pollution or degradation from occurring, continuing, or recurring. If such harm to the environment is authorised by law or cannot reasonably be avoided or stopped, such person must minimise and rectify such pollution or degradation of the environment
Employee	(OHS Act) means, subject to the provisions of subsection (2), any person who is employed by or works for an employer and who receives or is entitled to receive any remuneration or who works under the direction or supervision of an employer or any other person
Employer	(OHS Act) means, subject to the provisions of subsection (2), any person who employs or provides work for any person and remunerates that person or expressly or tacitly undertakes to remunerate him/her, but excludes a TES (ex labour broker) as defined in section 1(1) of the Labour Relations Act 1956 (Act No. 28 of 1956)

CONTROLLED DISCLOSURE

When downloaded from the document management system, this document is uncontrolled and the responsibility rests with the user to ensure it is in line with the authorised version on the system.

No part of this document may be reproduced without the expressed consent of the copyright holder, Eskom Holdings SOC Limited, Reg No 2002/015527/30.

Definition	Explanation
Environment	(32-94) means: a) the land, water, and atmosphere of the earth; b) micro-organisms and plant and animal life; and c) any part or combination of (a) and (b) and the interrelationships among and between them, and the physical, chemical, aesthetic, and cultural properties and conditions of the foregoing that influence human health and well-being
Eskom requirements	Eskom requirements flowing from directives, policies, standards, procedures, specifications, work instructions, guidelines, or manuals
Fall protection plan	(OHS Act) means a documented plan of all risks relating to working from an elevated position, considering the nature of work undertaken, and setting out the procedures and methods to be applied in order to eliminate the risk
Hazard	(OHS Act) means a source of, or exposure to, danger
Hazard identification	(OHS Act) means the identification and documenting of existing or expected hazards to the health and safety of persons, which are normally associated with the type of construction work being executed or to be executed
Occupational Health and safety file	(OHS Act) means a file or other record in permanent form, containing the information required in relation to the contract.
Health and safety plan	(OHS Act) means a document plan that addresses hazards identified and includes safe work procedures to mitigate, reduce, or control hazards identified
Occupational Health and safety specification	(OHS Act) means a document specification of all health and safety requirements pertaining to associated to a contract, so as to ensure the health and safety of persons.
Occupational Health and safety requirements	means comprehensive health and safety requirements for a contract, project, site, and scope of work. This specification is intended to ensure the health and safety of persons, both workers and the public, and the duty of care to the environment. The health and safety requirements must be specific to each contract, project, site, and scope of work
Lifesaving Rules	(240-62196227) a rule that, if not adhered to, has the potential to cause serious harm to people
Medical Certificate of fitness	(OHS Act) means a certificate valid for one year, issued by an occupational health practitioner, issued in terms of the regulations, whom shall be registered with the Health Professions Council of South Africa
Medical surveillance	(OHS Act) means a planned programme or periodic examination (which may include clinical examinations, biological monitoring, or medical tests) of employees by an occupational health practitioner or, in prescribed cases, by an occupational medicine practitioner
Method statement	(OHS Act) means a written document detailing the key activities to be performed in order to reduce, as reasonably as practicable, the hazards identified in any risk assessment
National Enquiries/contracts	sourcing of services providers/contractors at the divisional level and not at BU level thorough tendering, request for price etc

CONTROLLED DISCLOSURE

When downloaded from the document management system, this document is uncontrolled and the responsibility rests with the user to ensure it is in line with the authorised version on the system.

No part of this document may be reproduced without the expressed consent of the copyright holder, Eskom Holdings SOC Limited, Reg No 2002/015527/30.

Definition	Explanation
Organisation	may be defined as a group of individuals (large or small) that is cooperating under the direction of executive leadership in accomplishment of certain common objects
Pre-job meetings	(34-227) means a meeting that is held prior to the commencement of the day's work and that is attended by all the relevant employees associated with the work task
Main contractor	(In the text of this document) Means an employer, as defined in section 1 of the OHS Act, who intends to tender for or has signed a contract with Eskom for services rendered.
Provincial director	(OHS Act) means the provincial director as defined in Regulation 1 of the General Administrative Regulations under the Act
Responsible Manager	Is a Manager of a department, section or operating/business unit who has been appointed as part of the Eskom delegation of authority process with the aim to assist the applicable 16(2) assigned person in executing his/her duties in terms of the Occupational Health and Safety Act
Risk assessment	(OHS Act) means a programme to determine any risk associated with any hazard at a construction site in order to identify the steps needed to be taken to remove, reduce, or control such hazard.
Site	(34-228) means an Eskom department, unit, complex, building, specific project, work site, or the site where agents, clients, Main contractors, contractors, suppliers, vendors, and service providers provide a service to Eskom, directly or indirectly
Service provider	any private person or legal entity that provides any service(s) to Eskom for compensation
Subsidiary	(32-94) an enterprise controlled by another (called the parent) through the ownership of greater than 50% of its voting stock
Supplier	(32-1034) means a natural or legal person who renders a service and may include the following current or potential supplier vendor, contractor, consultant
Task	(34-227) a segment of work that requires a set of specific and distinct actions for its completion
Toolbox talks	(34-227) where the team leader, after conducting pre-task planning, shares all the tasks at hand and discusses task allocation, the identified risks, and the control measures with all his/her team members on site before commencing a specific task and documenting the agreed strategy. (This shall be done to ensure common understanding of the tasks, risks, and control measures required.)
The Act	(OHS Act) means the Occupational Health and Safety Act No. 85 of 1993, as amended, and the Regulations thereto
Visitor	any person visiting a workplace with the knowledge of, or under the supervision of, an employer.

CONTROLLED DISCLOSURE

When downloaded from the document management system, this document is uncontrolled and the responsibility rests with the user to ensure it is in line with the authorised version on the system.

No part of this document may be reproduced without the expressed consent of the copyright holder, Eskom Holdings SOC Limited, Reg No 2002/015527/30.

2.4 ABBREVIATIONS

Abbreviation	Description
BU	Business Unit
CE	Chief Executive
COID Act	Compensation for Occupational Injuries and Diseases Act
DMR	Driven Machinery Regulations
DEL	Department of Employment and Labour (Inspection and Enforcement services – Provincial office)
EP	Emergency Preparedness
EAP	Employee Assistance Program
ERfW	Environmental Regulations for Workplaces
GAR	General Administrative Regulations
GSR	General Safety Regulations
HCS	Hazardous Chemical Substances
LDV	Light Delivery Vehicle
MSDS	Material Safety Data Sheets
OHS Act	Occupational Health and Safety Act and Regulations, 85 of 1993
O&M	Operating and Maintenance
LoG	(COID) Letter of Good Standing
SABS	South African Bureau Standard
SANS	South African National Standard

2.5 RELATED/SUPPORTING DOCUMENTS

Section 37(2) of the OHS Act requires Eskom to sign an agreement and include it in the OHS file for evaluation prior to the start of work. OHS department will issue the 37(2) agreement to the project manager/end user who will facilitate the signing of the document by Eskom and contractor representatives.

CONTROLLED DISCLOSURE

When downloaded from the document management system, this document is uncontrolled and the responsibility rests with the user to ensure it is in line with the authorised version on the system.

No part of this document may be reproduced without the expressed consent of the copyright holder, Eskom Holdings SOC Limited, Reg No 2002/015527/30.

3. DOCUMENT CONTENT

3.1 SCOPE OF WORK

The detailed scope of work for this project must be listed here

3.1 DESCRIPTION OF SERVICE

3.1.1 Executive Overview

The Contractor shall provide scheduled preventative and corrective maintenance services for the Fire Detection System (FDS) at Grootvlei Power Station and Vaal Dam Pumping Station over a period of 60 months.

All maintenance activities shall be carried out in accordance with:

- GVLEG 0251 - Maintenance of Honeywell Fire Detection System Procedure
- OEM manufacturer recommendations and industry best practices

The Contractor is required to respond within 5–8 hours for critical faults that impact system functionality.

Note: The Fire Detection System is currently a mix of XLS1000 and XLS3000 panels, with the XLS1000 system being obsolete. The Employer is pursuing an open tender process for system replacement. Until the upgrade is complete, the contractor shall continue to maintain both systems.

3.1.2 EMPLOYER'S REQUIREMENTS FOR SERVICE

The contractor shall perform:

- Scheduled preventative maintenance of existing installations and field hardware
- Scheduled maintenance of fire detection system applications and databases
- Corrective maintenance to restore faulty components and ensure full system operation
- System fault diagnostics and troubleshooting
- Backup and recovery of critical system data
- Ensuring that maintenance documentation remains up to date

CONTROLLED DISCLOSURE

When downloaded from the document management system, this document is uncontrolled and the responsibility rests with the user to ensure it is in line with the authorised version on the system.

No part of this document may be reproduced without the expressed consent of the copyright holder, Eskom Holdings SOC Limited, Reg No 2002/015527/30.

3.1.3 FIRE DETECTION SYSTEM DESCRIPTION

Grootvlei Power Station's Fire Detection System (FDS) consists of the two parts, both provided by Equipment Original Manufactory (OEM) Honeywell. There is Honeywell XLS1000 system, as well as a XLS 3000 system. Both Systems are managed by the Honeywell (EBI) Enterprise Building integrator) system. The EBI System has two redundant server PCs as well as 2 Engineering PCs. Furthermore, the EBI server interfaces to the Honeywell DCS to allow for monitoring and control purposes.

3.1.3.1 Honeywell XLS1000 (Obsolete System – Maintenance Required Until Upgrade Completion)

- Installed: 2008
- Panels: 7
- Loops: 39
- Devices: 670 (Smoke Detectors, Heat Detectors, Call Points, etc.)
- Locations: Grootvlei Power Station, Vaal Dam, and Ash Water Return (AWR) plants

3.1.3.2 Honeywell XLS3000

- Installed: 2012
- Panels: 4 Main, 4 Auxiliary (RF-Linked)
- Devices: 530 (Smoke Detectors, Beam Detectors, Heat Detectors, Call Points, etc.)

Note: System mapping and documentation must remain up to date as part of ongoing maintenance (Keeping a log of maintenance activities, including any changes made to device configurations, ensuring all detectors, call points, and modules are correctly labelled in the monitoring system, etc.)

3.1.4. MAINTENANCE REQUIREMENTS

3.1.4.1 SCHEDULED PREVENTATIVE MAINTENANCE

Preventative maintenance shall be performed as per GVLEG 0251 and in compliance with SANS 10139. This includes:

3.1.4.1.1 Fire Detection Panels & Network

- Inspect panels for faults, alarms, and communication errors
- Verify and record power supply voltages for panels and connected devices
- Inspect and record battery condition (voltage, connections, load testing)
- Test fire panel response for mains failure

3.1.4.1.2 Fire Detectors & Field Devices

- Inspect, clean, and functionally test smoke and heat detectors
- Test manual call points to verify system response
- Ensure proper mounting and orientation of detection devices

CONTROLLED DISCLOSURE

When downloaded from the document management system, this document is uncontrolled and the responsibility rests with the user to ensure it is in line with the authorised version on the system.

No part of this document may be reproduced without the expressed consent of the copyright holder, Eskom Holdings SOC Limited, Reg No 2002/015527/30.

- Identify and address environmental factors affecting detector performance
- Check physical condition of equipment, panels and field devices and rectify where necessary

3.1.4.1.3 System Communication & Network

- Verify I/O module functionality and slot connectivity
- Check system communication integrity (wired and RF)
- Identify and resolve faults causing system downtime
- Ensure accurate mapping of field devices in the monitoring system
- Ping devices that are in the network station network including Vaal dam system
- Check and ensure communication status
- Check panels for alarms and faults, and reset panels where necessary and rectify any problems

3.1.4.1.4 Power Supply & Battery Maintenance

- Inspect power supplies and chargers for degradation
- Load-test batteries and verify backup runtime
- Check circuit breakers and power distribution boards for faults

3.1.4.2 CORRECTIVE MAINTENANCE & RESPONSE TIME

- Contractor must respond to critical faults within 5–8 hours
- Non-critical issues to be resolved within agreed SLAs (Service Level Agreements)
- Detailed fault logs must be maintained and submitted to the Employer

3.1.4.2.1 Corrective maintenance includes:

- Replacing faulty or degraded fire detection components
- Restoring system communication failures
- Investigating and mitigating false alarm occurrences
- Addressing recurring system issues to prevent repeat failures

3.1.4.3 SYSTEM DOCUMENTATION & REPORTING (SANS 10139 COMPLIANCE)

- The contractor must maintain up-to-date maintenance logs, including:
 - Date, time, and personnel responsible for maintenance activities
 - Observations, test results, and corrective actions taken
 - Device replacement records (model, serial number, installation date)

All maintenance and inspection records must be retained for at least five years and handed over to the onsite Employer for record-keeping. These records must be readily available for inspection upon request.

3.1.4.4 COMPLIANCE & SAFETY MEASURES

- Fire detection testing must be coordinated with site safety teams
- All work must comply with: SANS 10139 (Fire Detection and Alarm Systems for Buildings)

CONTROLLED DISCLOSURE

When downloaded from the document management system, this document is uncontrolled and the responsibility rests with the user to ensure it is in line with the authorised version on the system.

No part of this document may be reproduced without the expressed consent of the copyright holder, Eskom Holdings SOC Limited, Reg No 2002/015527/30.

- GVLEG 0251 (Maintenance of Honeywell Fire Detection System Procedure)
- All maintenance activities must minimise system downtime. Note: All tools and equipment required to provide the services as per the Employers requirements for the service will be at the contractor's cost.

3.1.5. SPARE PARTS & CRITICAL COMPONENT MANAGEMENT

- The employer will provide critical spares, but the contractor must:
- Identify and notify the employer of required spare parts before stock depletion
- Maintain a parts usage log
- Ensure installed spare parts do not void manufacturer warranties

3.1.6. ADDITIONAL MAINTENANCE CONSIDERATIONS

Additional recommendations for system reliability and futureproofing:

- Fire detection system mapping and documentation must be updated after maintenance
- Regular backup of EBI system data to ensure disaster recovery readiness. Ensure that data Back-up of data is carried out in-line with the back-up strategy which will be agreed with Employer.
- The contractor shall ensure and give proof of that, they will be able to maintain and do fault-finding on the EBI server.
- Firmware upgrades to be tested in a controlled environment before site deployment
- The Contractor is required to render preventative, routine and corrective maintenance on North stack dust and gaseous monitoring instruments for Grootvlei Power Station over a period of five (5) years

The activities for which the contractor is responsible for includes but not limited to the following:

- Examining, cleaning, testing, inspection of the monitor surrounding area and lifting machinery
- Visual inspection of analyser unit for cracks, corrosion or any other signs of physical damages
- Visual inspection of all cables, gas connecting pipes and fittings for integrity and any other sign of physical damages
- Adjusting the stack instruments on a regular basis in order to ensure reliability and integrity of the system and instruments at all times.
- The Contractor will also be required to repair all the defects found whilst doing previously mentioned maintenance and minor modifications where applicable.
- Execute Zero and Span calibration with certified test gas
- Provide detailed technical report and calibration/verification certificate

A copy of the scope of work must be retained by the contractor.

Note: The contractor who will be awarded this contract will be known as the **“Main contractor”** and any contractor appointed by the Main contractor will be known as the **“Appointed contractor”**

CONTROLLED DISCLOSURE

When downloaded from the document management system, this document is uncontrolled and the responsibility rests with the user to ensure it is in line with the authorised version on the system.

No part of this document may be reproduced without the expressed consent of the copyright holder, Eskom Holdings SOC Limited, Reg No 2002/015527/30.

3.2 LEGAL COMPLIANCE

3.2.1 Section 37(2) (Legal) Agreement

A section 37(2) agreement must be signed between Eskom and the main contractor at the time of submitting the safety file. The main contractor must ensure that a section 37(2) agreement is compiled between the main contractor and all their appointed contractors for the contract. The original copy of the section 37(2) agreement must be retained by the contractor, and a copy must be retained by the responsible project manager/end user. A copy of all the agreements must form part of the respective contractor's OHS file.

3.2.2 Hazardous Work by Children (Child Labour)

The constitution of the Republic of South Africa, in the "Bill of Rights", is clear on the rights of children, especially when it comes to:

1. *being protected from exploitative labour practices.*
2. *not be required or permitted to perform work or provide services that*
3. *are inappropriate for a person of that child's age; or*
4. *This places at risk the child's well-being, education, physical or mental health, or spiritual, moral, or social development* and the Basic Conditions of Employment Act, Chapter six, Section 43, "Prohibition of employment of children."

Before resorting to the use of child labour, due consideration must be given to the child's constitutional rights. Where work is being performed which is not prohibited in terms of the constitution, then such work must be conducted in terms of the OHS Act "Regulations on Hazardous Work by Children in South Africa" with emphasis on paragraph 2: Purpose and Interpretation. Eskom does not condone the use of child labour and, therefore, all effort must be exercised, and child labour should not be used.

3.2.3 OHS Act

The main contractor and appointed contractors shall have an up-to-date copy of the OHS Act and regulations which will be available to all employees.

3.2.4 Legislative Compliance

All contractors will comply with all the legislation pertaining to this contract being:

The Main contractor and all appointed contractors will comply with all the legislation pertaining to this project being:

- The Constitution of the Republic of South Africa (particularly Section 24 of the Bill of Rights).
- Occupational Health and Safety Act 1993 (Act 85 of 1993) and its Regulations.
- National Environmental Management Act 1998 (Act 107 of 1998).
- Environment Conservation Act 1989 (Act 73 of 1989).
- National Water Act 1998 (Act 36 of 1998).

CONTROLLED DISCLOSURE

When downloaded from the document management system, this document is uncontrolled and the responsibility rests with the user to ensure it is in line with the authorised version on the system.

No part of this document may be reproduced without the expressed consent of the copyright holder, Eskom Holdings SOC Limited, Reg No 2002/015527/30.

- Civil and Building Work Act.
- National Road Traffic Act 93 of 1996.
- Compensation for Occupational Injuries and Diseases Act.
- SANS Standards –Contractor shall use the relative standards applicable to the project.

3.3 ESKOM REQUIREMENTS

All contractors shall, before commencement of the project ensure that all their employees are familiar with the relevant Eskom OHS documentation that is applicable to contract services.

3.4 SHEQ POLICY

A SHEQ policy is a statement of intent and a commitment by the organization's CE and senior management in relation to the relevant OHS roles and responsibilities, the achievement of their strategic objectives, and values of integrity, customer satisfaction, excellence, and innovation. The main contractor and all appointed contractors, if not already in place, will be required to compile an organisational SHEQ policy in line with their OHS responsibilities. The policy must be signed by the organisation's CE or the appointed assistant to the CE, OHS Act Section 16(2). The policy must be displayed in a prominent place within the workplace. A copy of the policy must be filed in the contractor's OHS files and attached as an annexure to the OHS Plan.

3.5 COVID -19 POLICY

Due to the current pandemic the contractors are required to submit the Covid policy signed by the most senior person. The policy must be displayed in a prominent place within the workplace. A copy of the policy must be filed in the contractor's OHS files and attached as an annexure to the OHS Plan.

3.5.1 Covid -19 requirements

Covid-19 costs are not for profit making purpose and Eskom reserves the right to accept and/or decline the list of PPE which will be listed in the detailed Covid-19 costs. Due to the current pandemic the contractors are required to provide Eskom with a Covid-19 risk assessment and a detailed plan on how to prevent the spread of the virus and what control measures will be put in place to protect Eskom employees and members of the public. The risk assessment must include the following but not limited to, adherence to Covid-19 protocols in designated smoking areas. Covid-19 costs are applicable for the duration of the pandemic and the Covid-19 costs will be ceased once the country has declared that Covid-19 is no more a pandemic. The contractors have an obligation to comply with the National Disaster Management Act including the appointment of the Compliance Officer.

3.6 COID

The Main contractor and all his/her appointed contractors shall be registered with an appropriate employment compensation commissioner and have available a valid letter of good standing (LoG) from such commissioner.

CONTROLLED DISCLOSURE

When downloaded from the document management system, this document is uncontrolled and the responsibility rests with the user to ensure it is in line with the authorised version on the system.

No part of this document may be reproduced without the expressed consent of the copyright holder, Eskom Holdings SOC Limited, Reg No 2002/015527/30.

The obligation lies with the contractors to ensure that the LoG remain valid throughout the contract period. A copy of the LoG must be filed in the contractor OHS files.

3.7 COSTING FOR OHS WITHIN THE PROJECT

The costing for OHS must be itemised based on the overall scope of the project (i.e.) Training, provision of PPE, safety equipment purchases etc.

3.8 STATUTORY APPOINTMENTS

The Main contractor and all appointed contractors must appoint competent workers who will comply with the OHS Act for the duration of the contract. Before requiring appointees to accept an appointment, the employer must ensure that they have received appropriate training and/or information about their responsibilities. The relevant statutory appointments must be made in compliance with the OHS Act's criteria, which include appointing a qualified individual to the appropriate roles. The following should be included in the statutory appointments, but not limited to:

- OHS Act General Administrative Regulation 9(2) – Incident Investigator
- OHS Act Section 19 (3) - Health and Safety Committee Member
- OHS Act Section 19(6)(a) – Co-opted Health and Safety Committee member
- OHS Act Hazardous Chemical Substances Regulation 3(3) Hazardous Chemical Substances Co-coordinator
- OHS Act, Section 17 – Health and Safety Representative.
- OHS Act General Machinery Regulation 2(1) – Supervision of Machinery
- OHS Act: Pressure Equipment Regulations 11 & 12 Portable Gas Container Inspector
- OHS Act General Safety Regulations 3(4) – First Aider/s

3.8.1 Non statutory appointments

- Eskom requirement – Emergency Planning Co-coordinator
- Eskom requirement - Chairperson of Health and Safety Committee
- Eskom Site Manager
- Eskom Site Supervisor
- Risk Assessor
- Safety Officer
- Working at Heights planner

CONTROLLED DISCLOSURE

When downloaded from the document management system, this document is uncontrolled and the responsibility rests with the user to ensure it is in line with the authorised version on the system.

No part of this document may be reproduced without the expressed consent of the copyright holder, Eskom Holdings SOC Limited, Reg No 2002/015527/30.

3.9 ESKOM LIFE-SAVING RULES

1. Eskom places a high value on health and safety and urges every organization that undertakes work for Eskom to do the same.
2. Eskom has developed five life-saving guidelines that will apply to all Eskom employees, agents, consultants, and contractors. Any Eskom employee or employee of a Main Contractor or appointed contractor who fails to follow these rules would be deemed a serious violation. These rules are in place to protect any employee, labour broker, or contractor working from significant injury or death.
3. If any contractual work (including delivery of any product) is to be undertaken on Eskom premises, the rules shall be obeyed by any contractor and their employees.

The rules are:

RULE	DESCRIPTION OF RULE
Rule 1	OPEN, ISOLATE, TEST, EARTH, BOND, AND/OR INSULATE BEFORE TOUCH (That is plant, any plant operating above 1000 V)
Rule 2	HOOK UP AT HEIGHTS Working at height is defined as any work performed above a stable work surface or where a person puts himself/herself in a position where he/she exposes himself/herself to a fall from or into.
Rule 3	BUCKLE UP No person may drive any vehicle on Eskom business and/or on Eskom premises: Unless the driver and all passengers are wearing seat belts.
Rule 4	BE SOBER No person is allowed to be under the influence of intoxicating liquor or drugs while on duty
Rule 5	PERMIT TO WORK Where an authorisation limitation exists, no person shall work without the required permit to work.
Rule 6	ENSURE SAFE LIVE WORKING Ensure all live work basic principles are adhered to, as outlined in the High Voltage Live Working standard.

Eskom will take a zero-tolerance approach to these policies.

CONTROLLED DISCLOSURE

When downloaded from the document management system, this document is uncontrolled and the responsibility rests with the user to ensure it is in line with the authorised version on the system.

No part of this document may be reproduced without the expressed consent of the copyright holder, Eskom Holdings SOC Limited, Reg No 2002/015527/30.

Noncompliance to Life-saving rules is regarded serious misconduct and will result in serious disciplinary action, which may include dismissal.

This is to ensure that everyone who works on or visits an Eskom facility returns home to their families safely.

3.10 SUBSTANCE ABUSE

1. Alcohol and substance abuse are serious threats to any business, especially when it comes to workplace accidents and car driving. As a result, Eskom has the right to take reasonable procedures to identify and prohibit drunk people from entering the company.
2. General Safety Regulation 2A specifies the legal position on intoxication.
3. The allowable alcohol and drug level is 0%.
4. All contractors must follow Eskom's procedure 32-37 ("Substance Abuse Procedure"), taking into account that this is an Eskom Life-saving Rule number 4: (BE SOBER"), and anyone entering the Eskom site will be subjected to ad hoc alcohol testing if the BU has self-alcohol testing equipment.
5. Contractors are invited to develop their own manual and test their own employees for alcohol on a regular basis.
6. Test results must be marked "Confidential" and kept in the employee's personal file.
7. Eskom's life-saving rules must be included in the induction process.
8. All employees involved in the scope of work must sign the Life-saving rule pledge before commencement of work.

3.11 CONTRACTOR ORGANISATIONAL STRUCTURE

3.11.1 Main Contractor Organogram

The Main contractor must provide an organisational organogram on the company's letter head related to this contract, depicting all the levels of responsibility from the CE down to the supervisors responsible for the contract. List the relevant positions held, names of appointees, legal appointments and the Organogram must be signed off by the company's 16(1) or 16 (2).

The Main contractor must ensure that all appointed contractors comply with this requirement. The Main contractor is responsible for keeping copies of all the organograms' as well as submitting them with the OHS plan. All organograms shall be updated timeously when appointments are changed. This diagram must be kept up to date and filed in the project OHS files.

3.11.2 Appointed Contractor/s Organogram

1. Appointed contractors are required to compile their company organogram for the project on the company's letter head, listing the reporting structure from their CE down to their project supervisors. The diagram must list the names, positions held, any appointments made and must be signed off by the company's 16(1) or 16 (2).
2. This diagram must be kept up to date, a copy of which must be given to the Main contractor and a copy filed in the relevant project OHS files.

CONTROLLED DISCLOSURE

When downloaded from the document management system, this document is uncontrolled and the responsibility rests with the user to ensure it is in line with the authorised version on the system.

No part of this document may be reproduced without the expressed consent of the copyright holder, Eskom Holdings SOC Limited, Reg No 2002/015527/30.

3. This diagram must be kept up to date and filed in the project OHS files.

3.12 ROLES AND RESPONSIBILITIES

Commitment

Visible commitment is essential to providing a safe work environment. Managers, supervisors and employees at all levels must demonstrate their commitment by being proactively involved in the day to day operations, in particular the Occupational Health and Safety aspects of any project / contract. Legislation requires that each employee must take reasonable care of themselves and their fellow workers, from management level down to the lowest employee level.

3.12.1 Main contractors and appointed contractors

Note 1: Most of the roles and responsibilities listed apply to both Main contractors and any appointed contractors. Where some of the listed do not apply to both, then the specific responsibilities will be listed and titled. The contractors shall:

1. Carry out all duties as listed in section 8, 9 and 10, the various other regulations that form part of the OHS Act and Regulation 7 of the Construction Regulations.
2. Carry accountability and responsibility for the safety and health of their employees and their appointed contractors within their working area, as contemplated by section 37(2) of the OHS Act;
3. Shall keep a record of all employees including the appointed contractor employees, including date of induction, relevant skills and licenses and be able to produce this list at the request of the Eskom Project Manager.
4. Ensure that all their appointees are made aware of their accountabilities and responsibilities in terms of their appointment and that they advise and assist these appointees in the execution of their duties.
5. Ensure that the minimum legislative, regulatory and Eskom OHS requirements are complied with on all work sites.
6. Give the Eskom project managers and line managers / responsible managers their full participation and cooperation.
7. Compile a OHS (Occupational health and safety) file where all relevant health and safety records must be kept for each work site.
8. The Main contractor must provide the project manager with the Compensation Commissioner's valid letter of good standing before the commencement of work and any future renewal letters obtained during the contract for record-keeping purposes. The letter of good standing shall reflect the name of the contractor's company. Similarly, the Main contractor must provide the Eskom project manager with all the valid letters of good standing from their appointed contractors.
9. Contractors must provide the Main contractor with a certified copy of the Compensation Commissioner's valid letter of good standing before the commencement of work and any future renewal letters obtained during the contract for record-keeping purposes. The letter of good standing shall reflect the name of the contractor's company.
10. Appoint competent staff to perform the project work and ensure that all employees are trained in the health and safety aspects relating to such work and that the employees understand the hazards associated with all other work being carried out on the project.
11. Ensure that all employees are conversant with all relevant work procedures and that they adhere to such procedures. Similarly (without removing the appointed contractors' responsibilities), ensure that their appointed contractors and their employees are conversant with all relevant work procedures and that they adhere to such procedures.

CONTROLLED DISCLOSURE

When downloaded from the document management system, this document is uncontrolled and the responsibility rests with the user to ensure it is in line with the authorised version on the system.

No part of this document may be reproduced without the expressed consent of the copyright holder, Eskom Holdings SOC Limited, Reg No 2002/015527/30.

12. Co-ordinate the activities of all the appointed contractors in the interests of safety and health;
13. Ensure that their contractors (whom they intend appointing) have made detailed provision for the cost of safety and health measures throughout the project.
14. Stop his /her employees and any appointed contractors if such work poses a threat to the health and safety of persons or a risk of degradation to the environment.
15. Take reasonable steps to ensure cooperation between all their appointed contractors.
16. Ensure that Eskom OHS requirements are communicated to the appointed contractors, evaluate, and assess the appointed contractors OHS files. Only appoint contractors who are competent to do work, have satisfied the OHS compliance requirements and satisfied that the contractor has the necessary competencies and resources to perform the work safely.
17. Appoint full-time competent employees in writing to supervise the performance of all specified work throughout the contract period.
18. Ensure that the supervisor or manager do not supervise work on any site other than the site for which such supervisor has been appointed for.
19. Not victimise or dismiss employees, by virtue of the employee's divulging health and safety information or suspecting such information has been divulged, in the interests of health and safety requirements.
20. Follow a process of disciplinary action if any of their employees or their appointed contractor employees have transgressed any of the requirements of the health and safety specification, safety and health plans, site rules or any other requirements.
21. Before the commencement of work, review the submitted baseline risk assessments to include site or emerging risks. This should be done by a competent person appointed in writing with a view to identify hazardous and potentially hazardous work operations.
22. Ensure that pre-task risk assessments are conducted and documented daily and prior to the starting of any new task, irrespective of whether it is a repetitive task or not.
23. Must ensure that an organisation medical surveillance programme for the duration of the contract is in place and maintained.
24. Prior to having pre-employment and periodic medicals fitness examinations conducted, person/man job specifications must be compiled and handed to the occupational health practitioner.
25. Issue risk-based personal protective equipment (PPE) as a measure of last resort to their employees, inspect such equipment regularly and ensure recipients of PPE are trained in the proper use, care and where necessary, the maintenance of PPE;
Note: should the Main contractor or his/her appointed contractors entertain visitors on site, they will be held responsible for the provision and wearing PPE.
26. Must have a substance abuse program which must be in line with Eskom requirements.
27. Ensure that all incidents are reported and investigated timeously by competent incident investigators as and aligned with 32-95 requirements.
28. Be involved in all of their appointed contractor's incident investigations.
29. When appointing contractors, advise the project manager in writing timeously and obtain his/her approval prior to them commencing work.

3.12.2 Contractor site supervisor

The contractor site supervisor must be trained in the following:

- HIRA, Incident investigation training, Supervisor training, authorised person & PSR, Legal liability

Must:

1. Be competent to perform the required supervisory tasks;
2. Ensure their employees and all appointed contractors comply with the required statutory and Eskom project requirements;

CONTROLLED DISCLOSURE

When downloaded from the document management system, this document is uncontrolled and the responsibility rests with the user to ensure it is in line with the authorised version on the system.

No part of this document may be reproduced without the expressed consent of the copyright holder, Eskom Holdings SOC Limited, Reg No 2002/015527/30.

3. Inspect all work done by the contractors to ensure adherence to Eskom's standards and specifications
4. Conduct follow-up inspections to ensure findings are closed out and preventative action is in place.
5. Monitor contractors for adhere to statutory requirements and safety standards.
6. Monitor contractors overall OHS performance on site in order to achieve excellent results
7. Discuss all OHS related problems with the relevant contractor management timeously in the first instance and thereafter the Eskom project manager in the second instance relating to procedure requirements, non-conformances identified, corrective actions, audits and inspection schedules.
8. Continual liaison between the Main contractor, appointed contractors and employees.
9. Ensures that employees and appointed contractors are aware of latest standards, procedures, work instructions and safety regulations issued by Eskom:
10. Conduct site Inspections for compliance to OHS requirements and compiles the relevant inspection reports.
11. Submit the observation reports to the relevant management.
12. Submit the required OHS reports communicated by Eskom e.g., manpower numbers, incident statistics report etc
13. Have meaningful participation in the project statutory health and safety committee meetings.
14. Participate in all appointed contractor incident investigations.
15. Participate in the Main contractor's emergency preparedness planning.
16. Ensure that their own employees and those of any appointed contractor are competent to perform the tasks assigned.
17. Issue site instructions on behalf of the Main contractor where and when the appointed contractors deviate from safety requirements.

3.12.3 Contractor Health and Safety officer

- Safety Officer is not required for this contract.

The contractor health and Safety officer must be trained in the following:

- SAMTRAC, HIRA, Incident investigation training, Legal liability, Training, knowledge and understanding of ISO 4500, Minimum work experience 2yrs, OHS Diploma (applicable to 3-5 years contract)

3.13 RISK ASSESSMENT (REFER TO 32-520)

It is a legal requirement in terms of Section 8 (2)(d) of the OHS Act for an employer to carry out risk assessments, to establish which risks and hazards are attached to the health and safety of persons due to any work which is performed, any article or substance which is, handled, stored, transported. A risk assessment is defined as an identification of the hazards present in the activity, work, site, and an estimate of the extent of the risks involved, considering whatever precautions are already being taken.

It is essentially a three-stage process:

- identification of all hazards.
- evaluation of the risks;
- Measures to control the risks.

CONTROLLED DISCLOSURE

When downloaded from the document management system, this document is uncontrolled and the responsibility rests with the user to ensure it is in line with the authorised version on the system.

No part of this document may be reproduced without the expressed consent of the copyright holder, Eskom Holdings SOC Limited, Reg No 2002/015527/30.

Risk assessments are required to be maintained. This means that significant changes to a process or activity, or any new process or activity should be subjected to a risk assessment and that if new hazards come to light during the work process, then these should also be subjected to risk assessments. Risk assessments for long term processes should be periodically reviewed and updated. Method statements or written safe work procedures are an effective method as information and record of the way jobs / tasks must be performed. Daily or issue based or task specific or on the job risk assessments must be conducted at the place where work is to be performed/ conducted to allow managers and employees to assess any inherent risks that could have been overlooked during the initial risk assessment or any changes that might have occurred in a period of absence. For example if a job / task is extended over a day or halted due to inclement weather.

Guidelines for actual steps involved in a job/task specific risk assessment are:

- Each activity is listed.
- Specific hazards are identified and listed against each activity.
- The magnitude of each risk is rated as Low, Medium or High.
- All known documentary and supervisory controls are listed. For instance: What safe work procedures exist for ladders.
- The relevance, effectiveness and sufficiency of these controls are assessed.
- In the event of insufficient or deficient controls for the particular activity, steps to be taken to rectify this shall be recorded, and safe working procedures drawn up.
- Persons responsible for implementing and supervising the task shall be identified, nominated and duly assigned.
- Persons responsible for monitoring the task and carrying out the planned job observation must be nominated.
- Completed risk assessment shall be handed to the Eskom project manager representative for comment and approval.
- The relevant section of the risk assessment shall be issued with a Transmittal Note to the Supervisor nominated as the responsible person; and the names of workmen who have received instruction on the work content and the sequence of the activities listed in the risk assessment shall be recorded, and their competence established. This instruction shall be done through an interpreter if required and recorded on the Pre-Job Brief (Daily Safe Task Instructions), with reference to applicable Risk Assessments.

3.14 SAFE WORK PROCEDURES / METHOD STATEMENTS

There must be written safe work procedures for all activities, the safe work procedures must be aligned with the risk assessments. Method statements / written safe work procedure are control measures used to prevent an incident from occurring during the execution of the project. A written safe work procedure/ method statements provide guidance how to execute the task safely. A safe working procedure should be written when: -

- a. Designing a new job or task.
- b. Changing jobs or task;
- c. Introducing new equipment or substances; and

The safe working procedure should identify:

- d. The supervisor for the task or job and the employees who will undertake the task;
- e. The tasks that are to be undertaken that pose risks;

CONTROLLED DISCLOSURE

When downloaded from the document management system, this document is uncontrolled and the responsibility rests with the user to ensure it is in line with the authorised version on the system.

No part of this document may be reproduced without the expressed consent of the copyright holder, Eskom Holdings SOC Limited, Reg No 2002/015527/30.

- f. The equipment and substances that are used in these tasks;
- g. The control measures that have been built into these tasks;
- h. Any training or qualification needed to undertake the task;
- i. The personal protective equipment to be worn;
- J. Actions to be undertaken to address safety issues that may arise while undertaking the task.

3.15 ROOF WORK (REFER TO 32- 418)

Where roof work is to be performed, a risk assessment must be carried out prior to climbing on to the roof to determine the hazards i.e. stability, suitability and strength etc. The consequences of climbing and control measures that are required to be implemented should form part of the risk assessment and the fall protection plan. Should the weather change, the wind velocity must be measured before continuing with roof work.

3.16 FIRE EQUIPMENT AND MAINTENANCE

1. All firefighting equipment's that have been provided shall:
 - a. Be clearly labelled
 - b. Conspicuously numbered
 - c. Entered in a register
 - d. Inspected monthly by a competent person
2. Tested and serviced every 12 months.
3. Results entered in the register and signed by competent person.

3.17 FLAMMABLE AND COMBUSTIBLE LIQUIDS

1. Proposals to store fuel on site must have written approval from the Eskom Project Manager. The volumes of fuel allowed to be stored will depend on site conditions and Statutory Regulations e.g. by-laws.
2. For storage of hazardous and flammable liquids, a maximum storage as per the scope of work and the approval to be obtained from the local Municipality and to be complied with for the duration the project.
3. The maximum of 40 litres of fuel is allowed to be stored. Anything greater than 40 litres to be stored in a flammable/combustible liquid store with adequate spillage retention and proper labelling.
4. Adequate numbers of dry chemical fire extinguishers, each with a minimum capacity of 4.5 kg, shall be provided, installed and maintained.
5. All fuel storage areas must comply with the following requirements: -
 - a. Storage should be well clear of buildings.
 - b. Storage areas must be kept free from all combustible materials.
 - c. All Safety signs must be prominently displayed i.e.
 - Flammable Liquid.

CONTROLLED DISCLOSURE

When downloaded from the document management system, this document is uncontrolled and the responsibility rests with the user to ensure it is in line with the authorised version on the system.

No part of this document may be reproduced without the expressed consent of the copyright holder, Eskom Holdings SOC Limited, Reg No 2002/015527/30.

- No Smoking.
- No open flames.

- d. Adequate firefighting equipment must be available.
6. Diesel tanks are to be installed in a bunded area; bunded area must be able to contain 110% of tank capacity.
7. Bunded area shall be of a concrete or steel construction and lined with a leak proof sealing material.
8. Bunded area shall have a drain valve.
9. No other material/equipment shall be stored in the bunded area.
10. For storage of hazardous and flammable liquids, the approval must be obtained from the Fire department and/or the Municipality (if the services are rendered/available in the local Municipality).
11. The storage of flammable or hazardous storage must be well ventilated.
12. The appropriate Jerry cans designed for petrol/diesel shall be used to store petrol on Eskom sites and the appropriate colour coding should be complied with.

3.17.1 Refuelling at Eskom sites

Before a machine/vehicle can be refuelled, the motor must be stopped. Refuelling shall take place at designated safe areas and appropriate warning signs installed. Suitable drip trays must be used to prevent spillage at the filling nozzle.

3.18 FIRST AID AND EQUIPMENT

1. The requirements of the OHS Act GSR 3 must be observed.
2. First aid appointments must be made to meet the legal requirements. Appointees must be trained to level 2 and the training service provider must be registered in accordance with section 26(1) of the Skills Development Amendment Act, Act No. 37 of 2008. It is good practice for all employees to be trained to at least level 1.
3. When appointing employees for work sites, cognisance must be taken into account the type of work performed, the distance teams are working apart and the terrain to be covered if an emergency should arise.
4. A list of emergency numbers must be displayed on the notice boards and made accessible for all employees.
5. Main Contractor must ensure that his /her employees and appointed contractor employees are familiar with the emergency numbers.
6. Contractors shall have one first aid box for the first 5 persons and thereafter one for every 50 or team of workers on site or part thereof, taking into account the type of work performed and the distance between teams.
7. More first aid boxes shall be provided in accordance with the risk assessment. Boxes must be available and accessible for the immediate treatment of injured persons at the workplace.
8. For offices, signs indicating where the first aid box or boxes are kept as well as the name and contact details of the First Aider of such first aid box or boxes shall be erected.
9. The Main Contractor and appointed contractor shall ensure that alternative arrangements be made for incidents occurring after working hours.

CONTROLLED DISCLOSURE

When downloaded from the document management system, this document is uncontrolled and the responsibility rests with the user to ensure it is in line with the authorised version on the system.

No part of this document may be reproduced without the expressed consent of the copyright holder, Eskom Holdings SOC Limited, Reg No 2002/015527/30.

3.18.1 Boxes and equipment

The following is a list of minimum contents of a first aid box:

- Item 1: Wound cleaner/antiseptic (100ml).
- Item 2: Swabs for cleaning wounds.
- Item 3: Cotton wool for padding (100 g).
- Item 4: Sterile gauze (minimum quantity 10).
- Item 5: 1 Pair of forceps (for splinters).
- Item 6: 1 Pair of scissors (minimum size 100 mm).
- Item 7: 1 Set of safety pins.
- Item 8: 4 Triangular bandages.
- Item 9: 4 Roller bandages (75 mm X 5 m).
- Item 10: 4 Roller bandages (100 mm X 5 m).
- Item 11: 1 Roll of elastic adhesive (25 mm X 3 m).
- Item 12: 1 Non-allergenic adhesive strip (25 mm X 3 m).
- Item 13: 1 Packet of adhesive dressing strips (minimum quantity, 10 assorted sizes).
- Item 14: 4 First aid dressings (75 mm X 100 mm).
- Item 15: 4 First aid dressings (150 mm x 200 mm).
- Item 16: 2 Straight splints.
- Item 17: 2 Pairs large and 2 pairs medium disposable latex gloves.
- Item 18: 2 CPR mouth pieces or similar devices.

A content check list must be available with all boxes and boxes shall be checked on a regular basis, kept clean and dust free.

3.19 OHS COMMUNICATION SYSTEMS

1. Main Contractor/s and their appointed contractors must develop a communication strategy outlining how they intend to communicate OHS issues to their staff, the mediums they will employ and how they will measure the effectiveness of their OHS communication. Below is a brief on how communication should take place. Where project meetings are conducted on site, OHS shall be included as a standing agenda point and minutes of these meetings shall be available on site at all times. Minutes of meeting must be compiled and filed in the relevant OHS files. All employees shall have access to these minutes. Attendance register shall be kept for all the health and safety meetings.

3.19.1 Statutory Health and Safety Committees

1. The Main contractor shall establish statutory health and safety committee in terms of Section 19 of the OHS Act. Similarly, appointed contractors shall establish their own statutory health and safety committee.
2. All appointed contractors shall be members of the Main contractor's safety committee.
3. The Committee shall meet to discuss OHS issues concerning the current work being performed, training, upcoming work and OHS requirements, incidents and lessons learned specific OHS problems, safety performance, action plans and other relevant OHS issues. Listed below is a preferred agenda.
4. OHS representatives for a workplace shall be members of the relevant workplace safety committees (Refer to Section 19 (2) (a) of the OHS Act).

CONTROLLED DISCLOSURE

When downloaded from the document management system, this document is uncontrolled and the responsibility rests with the user to ensure it is in line with the authorised version on the system.

No part of this document may be reproduced without the expressed consent of the copyright holder, Eskom Holdings SOC Limited, Reg No 2002/015527/30.

5. The number of persons nominated by employer must not be more than the Health and Safety Representatives on that specific statutory health and safety committee. (Refer to Section 19(2)(c) of the OHS Act)
6. A statutory health and safety committee meeting shall be held at least 3 monthly (where medium to high risk work is involved, more frequent if required), and all appointed members of the committee shall attend the meeting.
7. Statutory health and safety committees may make recommendations to the Main contractor and the project manager and the Inspector at DEL.
8. All health and safety committees shall discuss all projects related OHS Act Section 24 and 25 incidents and other notified serious incidents.
9. Health and safety committees shall follow up on incident investigation recommendations and shall keep record of all recommendations made by the committee.
10. Statutory health and safety committees may make recommendations for the revision of current standards, procedures and practices.
11. The Main contractor and appointed contractors shall ensure that statutory and non-statutory health and safety committees carry out their duties.
12. The chairperson of the health and safety committees shall be selected and appointed by the contractor. The appointed chairperson must be competent to chair meetings and be able to make informed decisions.

3.19.2 Non-statutory health and safety committees

1. Where there are large worksites, then non-statutory sub-committee must be established within that worksite to assist with the communication of health and safety related matters between the statutory health and safety committee and the workplace.
2. The duties and responsibilities of the non- statutory health and safety committees will be the same as the statutory safety committee

3.19.2.1 Agenda

1. The following serves as the guideline for the OHS Committee meeting agenda.
 - List of agenda items:
 - Matters arising from previous minutes
 - Matters arising from Contractor's OHS meetings.
 - Covid-19 compliance
 - Audit results and feedback
 - Review Health and Safety Representative Inspection Reports
 - Review
 - Incident investigation reports
 - Non-Conformances
 - Announcements (near miss/injury/damage)
 - Follow up on recommendations made by the employer in incident investigation reports

CONTROLLED DISCLOSURE

When downloaded from the document management system, this document is uncontrolled and the responsibility rests with the user to ensure it is in line with the authorised version on the system.

No part of this document may be reproduced without the expressed consent of the copyright holder, Eskom Holdings SOC Limited, Reg No 2002/015527/30.

- Accident Prevention – Safety Promotion
 - Planned Job Observations
 - OHS Training
 - Protective clothing and equipment
 - Incident Announcements / Recall
- Forthcoming High hazard activities.
- Non-conformances.
- Housekeeping.
- Work permits.
- Work procedures.
- Hazardous materials / substances.
- Fire Prevention
- Occupational Hygiene Assessments, Health Risks and Actions
- Security
- Rules, Instructions
- Public Safety
- Environmental Management
- Emergency Preparedness
- Statistics report
- Closure

3.19.2.2 Minutes and action items for all health and safety committee meetings

1. Minutes and record of action items shall be kept of all health and safety committee meetings.
2. Action column with target dates and responsible person shall be clearly visible on the minutes and shall be completed during the meeting.
3. Statutory health and safety committee meeting minutes and record of action items shall be kept for the duration of the project or a minimum period of three years.
4. Non–statutory health and safety committee meeting minutes shall be kept for the duration of the project or a minimum period of 12 months.
5. All other meeting minutes where OHS is on the agenda, shall be kept for a minimum period of 12 months.
6. The original copy of the minutes and record of the action items must be signed by the chairperson.
7. The relevant project manager and Main contractor shall endorse the relevant minutes with his/her recommendations and return the minutes to the relevant contractors chairperson within 14 calendar days of the meeting.

3.20 TOOL BOX TALKS / DAILY TEAM TALKS / PRE JOB MEETINGS

1. A meeting must be held prior to the commencement of the day's work with all relevant personnel associated with the work task in attendance. The job, relevant procedures, associated hazards, safety measures, i.e. the task risk assessments shall be discussed. Each employee who attends the briefing

CONTROLLED DISCLOSURE

When downloaded from the document management system, this document is uncontrolled and the responsibility rests with the user to ensure it is in line with the authorised version on the system.

No part of this document may be reproduced without the expressed consent of the copyright holder, Eskom Holdings SOC Limited, Reg No 2002/015527/30.

shall sign an attendance list of that pre-job brief form undertaking that they have an understanding of the tasks, risks and control measures required.

2. Where possible, tool box talks can be included in the pre-job brief meetings. If this does not occur, then weekly tool box talks must be conducted. The toolbox talk topics will be based on OHS issues pertaining to the project site. The topic and the contents shall be in writing. Attendance registers with the topic listed shall be kept.

3.21 OHS TRAINING

1. The Main contractor, when making a bid for this project shall provide a breakdown list of the OHS training requirements and the costing of such requirements. Similarly, appointed contractor must provide the same requirements when bidding with the Main contractor.
2. The scope of training includes but is not limited to the type of work being performed and the relevant procedures. Additional to the requirements, will be that the Main contractor and appointed contractors must have the appropriate qualifications, certificates and employees should always be under competent supervision.
3. Where legislative and Eskom recommended appointments are made, the relevant training shall be given to those appointees prior to the acceptance of those appointments.
4. When there is an amendment to the Acts and/or to the regulations, OHS specification and OHS plan, all affected staff shall undergo the applicable refresher training.
5. Appropriate time must be set aside for training (induction and other) of all employees.
6. Records of all training and qualifications of all contractor employees must be kept on the OHS file.

3.21.1 Main Contractor Induction training

The contractor is required to make arrangements with the Business Unit for its employees to attend induction in order to be granted permission to access site.

1. The Main contractor shall ensure that all his / her employees, appointed contractors and their employees have undergone the Eskom OHS induction training prior to commencing work on site.
2. Attendance registers must be completed of any induction training given, which must indicate that they have received and understood the induction training.
3. Prior to attending the induction training, all employees must undergo a pre-employment medical examination and found fit for duty. A copy of the certificate of fitness must be kept in the OHS file on site for the duration of the project.
4. All employees and visitors on site shall carry the proof of induction training.
5. It is the contractors responsibility to keep records of induction training.

3.21.2 Appointed Contractor induction training

The Main contractor shall ensure that all his / her employees and appointed contractor employees undergo site specific work induction with regard to the approved project OHS plan, hazards prevalent on the work site,

CONTROLLED DISCLOSURE

When downloaded from the document management system, this document is uncontrolled and the responsibility rests with the user to ensure it is in line with the authorised version on the system.

No part of this document may be reproduced without the expressed consent of the copyright holder, Eskom Holdings SOC Limited, Reg No 2002/015527/30.

scope specific risk assessment, rules and regulations, and other related aspects. The induction training should also include identification of sensitive features such as wetlands/vlei areas, red data species, graves, etc.

3.21.3 Visitors to site induction

1. Visitors to the site shall be required to undergo and comply with the Eskom site-specific safety induction prior to being allowed access to site.
2. All visitors must remain in the care and custody of a person (host) who has been properly inducted. No visitors are permitted to undertake any work onsite, of any nature.
3. Visitors who have completed site induction must be provided with a record of proof of Induction training.

3.22 GENERAL TRAINING

The Main contractor will be required to ensure that before an employee commences work on the project/site, the respective supervisor informs the employee of his scope of authority, the hazards associated with work as well as the control measures to be taken. This will include man-job specifications, the discussion of any task procedures or hazardous operational procedures to be performed by the employee. The Main Contractor is to ensure that the supervisor has satisfied himself that the employee understands the hazards associated with the work to be performed by conducting task/job observations.

3.23 CONTRACTOR SITE ESTABLISHMENT

where contractors are providing their own facilities, the following shall apply:

1. Prior to establishing a project site, a site plan is required to be drawn and submitted to the project manager, listing position of all buildings, amenities, storage, stacking areas and temporary electrical installations. The appropriate colour coding and demarcation of storage and stacking areas must be carried out.
2. When compiling the site plan, cognisance must be taken to the establishment of the site camp, ablution facilities and dining area in relation to one another and away from stacking and storage areas.
3. Main contractor's site facilities should be managed and kept hygienically clean.
4. Where the materials are stored at the work sites, proper stacking and storage shall be carried out and maintained in good order at all times.
5. The contractor shall during the enquiry make provision for the Occupational Hygiene Surveys costs in the bill of quantities as per the OHS Act and its regulations and inline with the scope of work.
6. Contractors are expected to establish and complete site within 3 months of contract inception.

Where Eskom is making provision of the facilities to the contractor, the following shall apply:

1. Prior to handing over the site to the contractor, the client (project managers/end users) shall together with the contractor management conduct inspections, draft and sign the service level agreement.
2. Main contractors shall manage and keep the allocated Eskom facility hygienically clean at all times.
3. It is the responsibility of the contractor to maintain and keep the facility in a good condition.

CONTROLLED DISCLOSURE

When downloaded from the document management system, this document is uncontrolled and the responsibility rests with the user to ensure it is in line with the authorised version on the system.

No part of this document may be reproduced without the expressed consent of the copyright holder, Eskom Holdings SOC Limited, Reg No 2002/015527/30.

4. It is the contractor's responsibility to immediately report to the Eskom contract manager/project manager the defects incurred.
5. Eskom reserves the right to conduct unannounced site inspections.

3.24 SITE ROADS

1. When planning, sufficient areas must be allocated for parking of vehicles and mobile equipment's as well as roadways for ease of manoeuvrability of these vehicles.
2. Sufficient width roads to be provided and adequate space is to be allowed for large vehicles traversing the sites.

3.25 VEHICLE MANAGEMENT

1. It is the responsibility of the driver to ensure:
 - a. Their passengers wear seat belts whilst the vehicle is in motion.
 - b. Comply with all traffic road rules, safety, direction and speed signs.
 - c. Ensure that vehicle loads are properly secured prior to moving off.
 - d. Ensure that vehicles are not overloaded.
2. No persons maybe transported at the back of the bakkie.
3. Drivers are required to conduct the route risk assessment prior to travelling/driving.
4. No drivers or operators may text, talk on cell phones or two-way radios whilst driving.
5. All drivers shall have a valid medical fitness certificate.
6. The First aid box with valid contents and fire extinguishers must be included in the vehicle, be services annually and inspected monthly. Drivers must be trained on how to use the First aid box and fire extinguishers.
7. Two triangles must be included in the vehicle and the emergency number be displayed at the back of the vehicle.
8. Each Project site that is enclosed by demarcation will have system/ process to manage vehicle access to site.
9. Contractor must maintain their vehicles in a roadworthy condition and a vehicle license must be valid at all times and this is applicable to yellow plant.
10. Drivers of light vehicles must avoid stopping or parking in the vicinity of machines. At least 30 (thirty) meters must be left clear between such a vehicle and such a machine.
11. Contractor vehicles can be subject to inspections by the Client/Agent's representative. Vehicles which are not roadworthy will not be permitted to be used on site.
12. Drivers/operators shall be responsible for the travel-worthiness of all loads conveyed by them. Precautions shall be taken to secure all loads properly. Loads projecting from vehicles shall be securely loaded and in daytime a red flag and during darkness a red light or red reflective material shall be attached to the extreme end of such projecting materials.
13. The vehicle inspection checklist must include but not limited to:
 - Reverse alarm / beeper

CONTROLLED DISCLOSURE

When downloaded from the document management system, this document is uncontrolled and the responsibility rests with the user to ensure it is in line with the authorised version on the system.

No part of this document may be reproduced without the expressed consent of the copyright holder, Eskom Holdings SOC Limited, Reg No 2002/015527/30.

- Yellow reflective tape
- Mud flaps
- Fire Extinguisher
- 2 Triangles
- First Aid Box
- Safety belts for every seat
- No fold-up or jockey seat
- Tyres
- License disc
- Yellow reflective tape that must be fitted at a height of between 250mm and 1.5 metres
- Speed warning sign (100km/h) at the back of the minibus
- Driver have a Public Driving Permit

3.26 HOUSEKEEPING AND ORDER

1. All contractors shall maintain a high standard of housekeeping within their sites and vehicles for the duration of the project/contract.
2. Prompt disposal of waste materials, scrap and rubbish is essential and be stored temporarily in a designated waste area, awaiting disposal.
3. Materials/objects shall not be left unsecured in elevated areas – falling objects may cause serious injuries/fatalities.
4. Nails protruding through timber shall be bent over or removed so as not to cause injury.
5. All packaging material including boxes, pallets, crates, etc. to be removed from the work area immediately.
6. On completion of his / her work, the contractor is responsible for clearing his / her work area of all materials, scrap, temporary buildings and building bases to the satisfaction of the client/agent.
7. In cases where an inadequate standard of housekeeping has developed, compromising safety and cleanliness, anyone has the responsibility to bring it to the attention of the Main contractor in the first instance and the Eskom project/contract manager in the second instance.
8. The Eskom project/contract manager has the right to instruct the Main contractor and appointed contractors to cease work until the area has been tidied up and made safe. Neither additional costs nor extension of time to the contract shall be allowed as a result of such a stoppage. Failure to comply with this requirement will result into site cleaning by another cleaning contractor company at the cost of the Main contractor.
9. The Main contractor shall carry out regular safety/housekeeping inspections daily to ensure maintenance of satisfactory standards. The Main contractor shall document the results of each inspection and shall maintain records for viewing.

3.27 STACKING AND STORAGE

1. The competent personnel must be appointed in writing to manage and supervise all stacking and storage on site.

CONTROLLED DISCLOSURE

When downloaded from the document management system, this document is uncontrolled and the responsibility rests with the user to ensure it is in line with the authorised version on the system.

No part of this document may be reproduced without the expressed consent of the copyright holder, Eskom Holdings SOC Limited, Reg No 2002/015527/30.

2. Before stacking any material, the contractors or their employees must consult the contract manager for authorisation to use such an area for stacking purposes. This is to prevent haphazard arrangements.
3. Adequate care must be taken by the contractor to ensure that storage and stacking is carried out correctly and safely.
4. Correct shelf stacking must be carried out, heavy and bulky on the bottom, light and small on top.

3.28 WORKPLACE SIGNAGE AND COLOUR CODING

1. Symbolic safety signage shall be displayed where it is required by legislation.
2. All symbolic safety signage shall conform to the requirements of SANS standard 1186.
3. Signs shall be positioned to be seen from most positions within the work sites / areas.
4. All signage must be clear at all times and be replaced timeously when worn out.
5. Contractors establishing sites must erect a company sign at their site offices to reflect the name and contact details of the: contractor site/responsible manager; supervisors; Health and Safety Manager/Practitioner; First Aider; Health and Safety Representative and Evacuation warden.
6. The location of every first aid box; fire extinguisher and emergency exit is to be clearly indicated by means of a sign.
7. When using, an explosive power tool the appropriate signage shall be erected, warning people of its use.
8. Contractors shall provide signage where work is conducted and where unauthorised entry is prohibited and/or where alerting and cautioning passers-by to be aware of potential dangers.
9. The meanings of the appropriate symbolic signage must be discussed during induction training and toolbox talks.
10. Where possible, within workshops, work areas and established premises, the appropriate sign indicating the meaning of symbolic safety signs must be displayed.

3.29 TOOLS AND EQUIPMENT

1. Contractors shall ensure that all tools and equipment are identified, safe to be used and is maintained in a good condition.
2. Contractors shall ensure that all tools and equipment are listed on an inventory list, be regularly inspected at least monthly or as required by legislation and risk assessments. The equipment should be numbered or tagged so that it can be properly monitored and inspected.
3. Where applicable, tools and equipment must have the necessary approved test or calibration documentation prior to being brought onto the project and the records shall form part of the OHS plan. Maintenance calibration shall be undertaken in terms of the manufacturer's requirements.
4. All fuel driven equipment must be properly maintained in accordance with the manufacturer's recommendations and legal requirements.
5. Eskom reserves the right to inspect tools or items of equipment brought to site by contractors for use on this project.
6. Should Eskom personnel find any item that is inadequate, faulty, unsafe or in any other way unsuitable for the safe and satisfactory execution of the work for which it is intended, the Eskom personnel shall

CONTROLLED DISCLOSURE

When downloaded from the document management system, this document is uncontrolled and the responsibility rests with the user to ensure it is in line with the authorised version on the system.

No part of this document may be reproduced without the expressed consent of the copyright holder, Eskom Holdings SOC Limited, Reg No 2002/015527/30.

advise the contractor in writing and the contractor shall forthwith remove the item from site and replace it with a safe and adequate substitute.

Note: In such cases, the contractor shall not be entitled to extra payments or extensions of time in respect of delay caused by Eskom's instructions.

7. Where defective tools and equipment's are identified, such tools and equipment shall be removed out of site immediately, locked away to prevent further use until such time as the tool or piece of equipment has been repaired.
8. Contractors shall ensure that the appropriate records are kept for all tools and equipment used on the project. Such tools and equipment's shall be subjected to regular inspections.

3.29.1 Hand tools

1. All hand tools (hammers, chisels, spanners, etc.) must be recorded on a register and inspected by the construction supervisor on a monthly basis as well as by users prior to use.
2. Under no circumstance will the contractors be allowed to use their equipment's with mushroom heads, to be removed at the end or beginning of shift prior to use.
3. Tools with sharp points in toolboxes must be protected with a cover.
4. All files and similar tools must be fitted with handles.
5. No make shift tools are permissible on the project.

3.30 LADDERS

1. Ladders used shall conform to the requirements of GSR 13A and used in terms of GSR 6.
2. The appropriate head protection, with chin strap shall be worn by employees working from a ladder or with climbing irons.
3. The ladder wheels, brakes and platform must be in good condition.
4. All metal parts to be in good condition, no cracks.
5. The appropriate head protection, with chin strap shall be worn by employees working from a ladder or with climbing irons.
6. Non-slip devices must be in good condition and no paint to be on wooden ladders
7. Climbing irons are permitted to be used in place of ladders on condition that the requirements of GSR 6 are not compromised and from an electrical point of view not damage any cabling. The working at heights risk assessment must indicate the use of climbing irons.
8. Employees using climbing irons shall be suitably trained in the use, care and maintenance of such climbing irons.
9. When using climbing irons, the appropriate rope grab fall prevention system shall be used.
10. The correct fall protection equipment shall be worn and used whilst climbing up, working from and climbing down ladders.
11. The appropriate head protection, with chin strap shall be worn by employees working from a ladder (risk based) or with climbing irons.

CONTROLLED DISCLOSURE

When downloaded from the document management system, this document is uncontrolled and the responsibility rests with the user to ensure it is in line with the authorised version on the system.

No part of this document may be reproduced without the expressed consent of the copyright holder, Eskom Holdings SOC Limited, Reg No 2002/015527/30.

12. A detailed inspection of all ladders shall be conducted monthly by a competent person and every time prior to climbing by employees using such ladders. The inspection check lists must be filed in the site OHS files

3.31 SCAFFOLDING

1. Scaffolding use shall conform to the requirements of Eskom procedure 32-418 and used in terms of GSR 6.
2. The requirements for using a scaffold platform shall be determined by the work at heights risk assessment.
3. All scaffolding that will be used shall conform to the SANS standard 10085.
4. Scaffolding shall be erected and inspected by the competent personnel.
5. The appropriate training for scaffold users shall be conducted prior to climbing on to the scaffold.
6. The correct fall protection equipment shall be worn and used whilst climbing up, working from and climbing down the scaffolds as the risk assessment.
7. A detailed inspection of all scaffolding shall be conducted at suitable intervals not exceeding seven days by a competent person and visual inspection shall be done every time prior to climbing by employees using such scaffolding. The inspection check lists must be filed in the site OHS files.
8. Visual inspections must always be carried out prior to every use.

3.32 AUDITING

3.32.1 Approval and compliance of Main contractor OHS plan

The Contractor's OHS Plan will be audited against compliance checklist so as to verify compliance to the requirements of the Eskom OHS specifications. Once there is compliance only then will the Main contractors OHS plan be approved by the project manager or an appointed Eskom contract custodian. The implementation of the OHS Plan shall be assessed / audited by Eskom personnel on a regular basis. This will include physical conditions evaluation.

3.32.2 Eskom OHS audits

Eskom shall evaluate all contractors' OHS performance on an ongoing basis against the legal, Eskom requirements, OHS specification and the contractors OHS plans.

Note: Eskom reserves the right to conduct unannounced audits on contractors

There will be scheduled audits conducted by Eskom on the Main contractor/s and/or appointed contractors. These audits shall be attended by the contractor's site manager or his representative.

If there are any findings / non-compliance identified as serious in these audits, an activity will be stopped for that specific Main Contractor and appointed contractor. Refer to section on "Work Stoppage" in this OHS Specification.

CONTROLLED DISCLOSURE

When downloaded from the document management system, this document is uncontrolled and the responsibility rests with the user to ensure it is in line with the authorised version on the system.

No part of this document may be reproduced without the expressed consent of the copyright holder, Eskom Holdings SOC Limited, Reg No 2002/015527/30.

3.32.3 Contractor audits

Main Contractors are required to conduct internal audits on both their employees and their appointed contractors on the implementation of their OHS Plan according to a frequency determined in a schedule or when the scope of work changes. A summary of the findings and the proposed corrective actions shall be submitted to Eskom project manager within one week after completion of the audit. Where appointed contractors are audited by the Main contractor a copy of the audit report shall be submitted to the appointed contractor within 7 days of the audit.

3.33 SMOKING

The national smoking policy must be observed and smoking is permitted in designated areas only (Eskom Smoking Procedure 32-36).

3.34 CELLULAR PHONES

The National Road Traffic Act requirements regarding the use of cellular phones must be observed, when driving and or operating mobile equipment and or machinery. The personal use of cell phones in the plant is prohibited unless it is an emergency or for work purpose. The use of cell phone camera in the plant must be in line with the national key point Act and the Plant safety regulation.

3.35 OCCUPATIONAL HEALTH, HYGIENE AND REHABILITATION

All contractors are required to develop an Occupational Health, Hygiene and Rehabilitation program. The program is intended to ensure that the risks to health are identified and controlled.

The contractor must provide training and information regarding the HCA's being transported.

Main contractor/appointed contractor must conduct or develop:

- Health Risk assessment report identifying hazards and risks that the employees are exposed to.
- Occupational Hygiene monitoring.
- Hygiene management Program for appropriate control of exposures.

The following records must be available for audits:

- Preventive actions (action plan feedback)
- Exposure survey results.
- Complaints records
- Communication records
- Reports on control of non-conformance and corrective action
- Records for training and awareness's
- PPE records (i.e. dust masks, ear plugs etc.).

Pre-existing medical conditions and restrictions must be declared with Eskom medical centre for management and accommodation of employees.

CONTROLLED DISCLOSURE

When downloaded from the document management system, this document is uncontrolled and the responsibility rests with the user to ensure it is in line with the authorised version on the system.

No part of this document may be reproduced without the expressed consent of the copyright holder, Eskom Holdings SOC Limited, Reg No 2002/015527/30.

3.35.1 Occupational Hygiene Hazards Identification and Risk Assessment Report (HIRA)

1. The main contractor must ensure that a HIRA is conducted for their employees by an AIA or a competent person in order to identify the health hazards inherent to specific job tasks and develop actions and recommendations to control health risks presented by hazards identified during this assessment.
2. The HIRA should evaluate health hazards presented by physical stressors such as illumination, noise, ventilation, heat stress, cold stress, vibration and radiation (ionising and non-ionising), ergonomical hazards, chemical agents, hazardous biological agents and psychological stress factors.
3. The HIRA should be conducted before commencement of any work activities and should be repeated if new processes (tasks) are introduced, or if existing processes or tasks are changed or modified. If unchanged, the assessment should in any event be repeated in 24 months.

3.35.2 Occupational Hygiene Monitoring Noise

1. Regulation 8 of the Noise Exposure Regulations, OHSAct (85 of 1993) requires that noise monitoring shall be carried out at the workplace, therefore, the main contractor must ensure that they conduct personal noise monitoring for their employees. Noise surveys must be conducted by an AIA and in accordance with national and / or international methods to evaluate noise rating levels at the workplace.
2. The measurement programme must be in accordance with the requirements of Chapter 3 (sampling of maximum risk employee) and 4 of the Occupational Exposure Sampling Strategy Manual (OESSM), published by the NIOSH, Publication No. 77-173 of 1977, United States of America: Department of Health, Education and Welfare.
3. The survey should be conducted during commencement of work activities to serve as a baseline and thereafter repeated if any of the processes, equipment or the layout of the work areas change, or if either the controls or assessment are no longer considered to be sufficient. If everything remains the same, the survey should be repeated in 24 months.

3.35.3 Hazardous Chemical Agents (Fly Ash, Respirable Dust and Respirable Crystalline Silica)

1. Regulation 6 of the Regulations for Hazardous Chemical Agents, 2021, OHSAct (85 of 1993) requires that air monitoring and the evaluation of employee exposure to hazardous chemical agents shall be carried out at the workplace, therefore, the main contractor must ensure that they conduct air monitoring for their employees. Air monitoring must be conducted by an AIA and in accordance with national and / or international methods to evaluate employee exposure at the workplace.
2. The measurement programme must be in accordance with the requirements of Chapter 3 (sampling of maximum risk employee) and 4 of the Occupational Exposure Sampling Strategy Manual (OESSM), published by the NIOSH, Publication No. 77-173 of 1977, United States of America: Department of Health, Education and Welfare.

CONTROLLED DISCLOSURE

When downloaded from the document management system, this document is uncontrolled and the responsibility rests with the user to ensure it is in line with the authorised version on the system.

No part of this document may be reproduced without the expressed consent of the copyright holder, Eskom Holdings SOC Limited, Reg No 2002/015527/30.

3. The survey should be conducted during commencement of work activities to serve as a baseline and thereafter repeated if any of the processes, equipment or the layout of the work areas change, or if either the controls or assessment are no longer considered to be sufficient. If everything remains the same, the survey should be repeated in 24 months.
4. The results of the respirable silica dust survey must be submitted to the Department of Employment and Labour in a prescribed format on a bi-annual basis.

3.35.4 Ergonomic Risk Assessment

1. Regulation 6 of the Ergonomics Regulations, OHSAct (85 of 1993) requires the responsible BU manager to have an ergonomic risk assessment performed by a competent person and the assessment should be conducted at intervals not exceeding two years, therefore, the main contractor must ensure that they conduct ergonomic assessments for their employees.
2. The assessment should be conducted during commencement of work activities to serve as a baseline and thereafter repeated if any of the processes, equipment or the layout of the work areas change, or if either the controls or assessment are no longer considered to be sufficient. If everything remains the same, the survey should be repeated in 24 months.

3.35.5 Medical Surveillance

Note: Eskom Power Station will only accept medical surveillances conducted by an Occupational Health Practitioner who holds a qualification in occupational health.

1. Main contractors must ensure that their employees and their appointed contractor employees have a medical surveillance program whereby their employees undergo entry, periodic and exit medical fitness examinations.
2. The health risk assessment must be used to compile the man job specification and address the hazards that the employees will be exposed to.
3. For the appropriate medical examinations to be conducted, each employee must have a man job specification, which must indicate the description of work, list of hazards and potential occupational exposure limits, physical hazards and required physical attributes.
4. Audiometric testing in accordance with Section 11 of SANS 10083 of 2013 should be done for employees working in noise zones, frequency of testing is dependent on levels of exposure.
5. Respiratory examination for increased upper respiratory system infections should be conducted for employees working in respiratory zones annually.
6. Medical fitness certificates shall be renewed annually for employees who are working on site. This shall be maintained until completion of the contract.
7. The Main Contractor must ensure that his / her employees and appointed contractor employees have undergone pre-entry medical examination before starting work on the contract.
8. The Main contractor shall provide a documented process for managing those employees who are issued with a conditional certificate of fitness.

CONTROLLED DISCLOSURE

When downloaded from the document management system, this document is uncontrolled and the responsibility rests with the user to ensure it is in line with the authorised version on the system.

No part of this document may be reproduced without the expressed consent of the copyright holder, Eskom Holdings SOC Limited, Reg No 2002/015527/30.

9. The contractor shall include in the OHS file the record of the employees exit medical fitness certificates as and when their employees leave the company.

3.35.5 information and Training

1. The main contractors must ensure that it provides its employees with information and training with regards to:
2. The content and scope of the Occupational Health and Safety Act (82 Of 1993).
3. Potential sources of exposure to health hazards.
4. Potential risks to health and safety caused by exposure to health hazards.
5. Measure taken by Eskom and main contractor to protect employees against detrimental effects of exposure to health hazards.
6. Precautions to be taken by employees to protect themselves against health and risks associated with exposure to health risk, including wearing of personal protective equipment.
7. The necessity, correct use, maintenance and limitations of personal protective equipment, facilities, and engineering controls provided.
8. Assessment of exposure, the purpose of occupational hygiene monitoring and necessity for medical surveillance and long0term benefits and limitations of undergoing such medical surveillance.
9. Procedures for reporting, correcting, and replacing defective personal protective equipment and engineering controls.

3.36 ROLES AND RESPONSIBILITIES

All contractors are required to list employee's roles and responsibilities pertaining to the contract.

3.37 WORKING AT HEIGHTS

3.37.1 General Requirements

Wherever reasonably practicable, preference is given to the performance of work at ground level as opposed to the elevated position. Where work in an elevated position is necessary, preference is given to fall prevention measures such as, but not limited to, effective barricading and the use of work platforms. Persons may only work from a fall risk position if a site-specific fall protection plan developed by the appointed competent person (as per 32-418 procedure) is in place and correctly implemented and consists of the following:

1. All appointments for the fall protection plan developer and implementer are in place.
2. Baseline risk assessment, which is specific and incorporates the working at height risk assessment, as well as the site-specific risk assessment, has been completed for the work to be conducted.
3. Safe working procedure/task analysis and work instructions, approved by a competent person, are in place.

CONTROLLED DISCLOSURE

When downloaded from the document management system, this document is uncontrolled and the responsibility rests with the user to ensure it is in line with the authorised version on the system.

No part of this document may be reproduced without the expressed consent of the copyright holder, Eskom Holdings SOC Limited, Reg No 2002/015527/30.

4. A fall rescue plan, along with necessary equipment's and trained rescuers, are in place.
5. Appropriate training, as determined by the risk assessment, has been provided.
6. Appropriate height safety equipment and personal protective equipment have been issued to the individual.
7. There are equipment inspection procedures and up-to-date inspection records.
8. Individuals are medically fit to work at height, and records of this are kept.
9. A site-specific risk assessment is performed.

While work is in progress, adequate warning signs and/or barricades shall be used in all areas where there is a risk of persons being injured by materials or equipment falling from the work area. Barricades should be continuous and easily visible.

A drop zone shall be established with appropriate warning signs and barricading, warning personnel below of workers above and potential falling objects.

Every employer shall ensure that work at height is:

1. properly planned;
2. appropriately supervised; and
3. carried out in a manner that is, as far as is reasonably practicable, safe and that its planning includes the selection of work equipment.

3.38 CONFINED SPACES

1. The contractor shall ensure that they comply with the plant safety regulation (240-150642762) in relation to the confined spaces.
2. The contractor must ensure that the station rescue emergency number is always available.
3. The contractor must ensure that at least one person or there is a responsible person who is trained on work that will be carried in the confined spaces, also to rescue and conduct the risk assessment.
4. The contractors shall develop their own confined space procedure.
5. The contractor shall ensure that the confined space procedure includes provision for training.
6. No personnel may enter a confined space before Eskom Grootvlei Power Station Safety and Chemistry personnel has assessed and issued gas test permit
7. Before entering a confined space, Contractor's Personnel shall obtain a Confined Space Entry Permit (a register for entry and exit of the confined space to be kept)
8. Only Contractor's Personnel who have been properly trained on the hazards associated with confined space work shall be allowed to enter a confined space.
9. Contractor must have own gas Monitors with NH₃, H₂S, SO₂, CO, LEL, O₂ & CO₂. Monitors must be calibrated by SANAS Accredited lab. Have means of bump testing/ on-site testing of monitors. Contractor shall ensure that employees are trained on use of monitor.

CONTROLLED DISCLOSURE

When downloaded from the document management system, this document is uncontrolled and the responsibility rests with the user to ensure it is in line with the authorised version on the system.

No part of this document may be reproduced without the expressed consent of the copyright holder, Eskom Holdings SOC Limited, Reg No 2002/015527/30.

10. The contractor shall ensure that an adequate number of suitable gas monitors are available to continuously monitor the confined space during entry. Before entering the confined space, all persons shall be given a briefing as to the precautions that must be taken.
11. While work is being performed in the confined space, a person with basic first aid training shall be immediately available to render emergency assistance if there is reason to believe that a hazard may exist in the space or if a hazard exists.
12. When the work in the confined space is completed, the person authorizing entry into the confined space shall verify that all persons have exited the confined space and that it is safe to remove the permit. The authorizing person shall then sign, date, and write in the time the permit was removed.

3.39 PERSONAL PROTECTIVE EQUIPMENT REQUIREMENTS

1. The Main contractor must provide a detailed programme that includes the issuing, maintenance and replacement of PPE for all his employees and appointed contractors on site.
2. All contractors shall comply with the requirements of GSR 2 of the OHS Act and PPE Specification Standard 240-44175132.
3. The risk based PPE matrix must be compiled detailing the types of PPE that is required to be issued to employees performing the respective tasks.
4. If there are exceptional circumstances in which certain activities necessitate the use of additional PPE, a risk assessment must be done, in which such PPE requirements will be determined and issued.
5. All contractors shall ensure that their visitors wear and use the correct PPE whilst on worksites.
6. Where PPE is required and visitors are not in possession of, then it is the individual contractor's responsibility to provide the PPE.
7. All PPE purchased and used by all contractor employees including visitors must comply with the relevant SANS standards.
8. Where deemed as a requirement (as per risk assessment), then high visibility vests shall be worn.
9. Monthly inspection records of PPE must be kept in the Safety file
10. The contractor shall provide training to his/her employees on the correct use, care and maintenance of PPE and keep the record.

3.40 INCIDENT INVESTIGATION

All incidents shall be investigated in terms of OHS Act General Administrative Regulations 8 and 9, using Eskom Procedure 32-95 OHS incident management as a reference, and where injuries as contemplated in sections 24 and 25 have been sustained, be reported to the Department of Employment and Labour.

Contractors shall use the Eskom Flash report to report incidents immediately or before end of shift. The standard General Administrative Regulation Annexure 1 "Recording of an Incident form" for all incident investigation reports. The objective of incident investigation, should not only be a legal requirement, but should establish why and how the incident occurred and find out the real root cause of the incident and to decide on precautionary measures that are required to address the root cause to prevent any further recurrences of the same or similar incidents.

CONTROLLED DISCLOSURE

When downloaded from the document management system, this document is uncontrolled and the responsibility rests with the user to ensure it is in line with the authorised version on the system.

No part of this document may be reproduced without the expressed consent of the copyright holder, Eskom Holdings SOC Limited, Reg No 2002/015527/30.

3.41 EMERGENCY MANAGEMENT

The art of emergency preparedness and response is to minimise the effects of any emergency and to restore normal activities as soon as possible. The contractor must develop and align their own Emergency response plan with Eskom's to address any emergency which might arise at any given point in time. The contractor to familiarise themselves with the Eskom emergency response plan and procedure. Periodic emergency drills must be undertaken to test the effectiveness of their plan. This must be recorded and provided on request.

3.42 NON-CONFORMANCE AND COMPLIANCE

1. Any non-compliance to any health and safety requirement in this OHS specification is subject to discipline in terms of the Eskom Procurement and Supply Chain Management Procedure.
2. Main contractors are required to implement a non-conformance procedure (if not already in place) for issuing to contractors for transgressions. The procedure can include "quality" related non-conformance issues. Similarly, appointed contractors must implement a non-conformance procedure.
3. The procedure for the issuing and closing off of non-conformance reports shall be strictly adhered to.
4. Contractor project management must monitor the close out of non-conformances issued, in not doing so; any recommendations made may not be implemented.
5. Where non-conformances are issued by Eskom then one of the close-out steps of the procedure will be for the offender to be called by the responsible project manager to explain the non-conformance issued and what plan is in place to prevent a recurrence of the non-conformance.
6. Should the contractor fail to provide adequate PPE (as per PPE standards) to their employees for the tasks being performed and/or to visitors; failure to enforce the wearing of such PPE will be viewed as a transgression of the legislative and Eskom requirements.

3.43 OHS FILES

1. OHS file means documents or records in permanent form, containing the information about the safety and health management system from inception, execution to completion of works.
2. All contractors are required to keep the OHS file on every project site. If there is more than one site per project, a file per site shall be kept at that site. Contractors may keep additional files at their head office as additional records. The OHS file shall be maintained by all the contractors on their project sites and shall be available on request for audit and inspection purposes.
3. The OHS file shall consist of the OHS documentation/information in line with the OHS requirements/specification, legal and other requirements.
4. The sequence of filing the documentation must be kept in the same sequence as listed in this OHS requirements /specification and the OHS plan.
5. Each record shall be separated by partitions to afford easy identification and access. Each partition must be labelled.
6. On completion of the work/project, the main contractor must hand over a consolidated health and safety file to the project manager.

CONTROLLED DISCLOSURE

When downloaded from the document management system, this document is uncontrolled and the responsibility rests with the user to ensure it is in line with the authorised version on the system.

No part of this document may be reproduced without the expressed consent of the copyright holder, Eskom Holdings SOC Limited, Reg No 2002/015527/30.

7. In case where the project is extended, should the documentation in the OHS files become cumbersome, the older documentation must be archived in boxes which shall be correctly labelled and be available for auditing purposes. The archived documentation must be handed over at the completion of the project.

3.44 WORK STOPPAGE

1. Any person may stop any activity where an unsafe act or unsafe condition that poses or may pose an imminent threat to the safety and health of an individual or create a risk of degradation of the environment. This includes any unauthorised work or service performed by, or legally or contractually non-compliant acts or omissions by, any contractor contracted to work at that site.
2. Work stoppages that are initiated due to OHS concerns, non-compliance, or poor performance related to the contractor's works or services shall not warrant any financial compensation claim lodged against Eskom where the contractor has not met the requirements defined legally or contractually.
3. Where stoppages are carried out, the required non-conformance report shall be raised.
4. All work stoppages ideally should be investigated and documented by contract custodians.

3.45 HOURS OF WORK

The requirements of the Basic Conditions of Employment Act, Chapter Two "Regulation of Working Time" must be adhered to. All contractors are required to maintain an accurate record of time worked by each employee.

3.45.1 Normal work

All work conducted on site shall fall within the legal requirements in accordance with the Basic Conditions of Employment Act. Contractors will notify their Eskom Supervisor or project manager of any work that needs to be performed after hours according to the agreed arrangements. (The application needs to be submitted timeously). Where applicable, the notification should include proof of application, for overtime, to the Department of Employment and Labour and /or the letter of approval from the Department of Employment and Labour.

3.45.2 Night work

When night work is to be performed, the baseline risk assessment must be reviewed to include the management of night work. Contractors shall provide sufficient lighting to enable the entire work site to be illuminated to a degree that employees will not work in dark (un-illuminated) or dimly lit areas. Care must be exercised as not to use few lights with high light intensives as this will cause night blindness.

If work is continuing from day light into night, at dusk, a tool box talk must be held where all employees will be advised of the hazards of night work and the extra precautions which require to be taken, i.e. poor housekeeping, stepping on uneven ground, stepping into holes etc.

3.45.3 Overtime

When overtime is required to be performed, the appointed contractors shall inform the Main contractor of such action. The Main contractor shall inform the Eskom project manager of such function and provide proof of exemption from the Department of Employment and labour. Contractors shall be aware of the effects of human

CONTROLLED DISCLOSURE

When downloaded from the document management system, this document is uncontrolled and the responsibility rests with the user to ensure it is in line with the authorised version on the system.

No part of this document may be reproduced without the expressed consent of the copyright holder, Eskom Holdings SOC Limited, Reg No 2002/015527/30.

fatigue and regulate overtime accordingly. The baseline risk assessment must be reviewed to include the management of overtime work.

3.46 OMISSIONS FROM SAFETY AND HEALTH REQUIREMENTS SPECIFICATION



By drawing up this OHS specification Eskom has endeavoured to address the most critical aspects relating to OHS issues in order to assist the contractor to adequately provide for the health and safety of employees on site.

Should Eskom not have addressed all OHS aspects pertaining to the work that is tendered for, the contractor needs to include it in the OHS plan and inform Eskom of such issues when signing the contract.

3.47 BARRICADING

Grootvlei Power Station has a legal obligation under the Occupational Health and Safety Act to ensure a work environment that is free from harm. Furthermore, Grootvlei Power Station also has an obligation to protect our co-workers, Business Partners (contractors) and members of the public, from hazards arising from any of the stations' activities. The need to barricade a work area may arise from the following identified hazards but not limited to: Falling objects or flying objects due to work at heights Falls into open trenches or excavations Exposure during radiation work Containment of hazardous chemical substances Contact with hot surfaces Burns and Eyes impairment from hot work operations or activities Exposure to risk of explosion.

Types of Barricading approved for use at Grootvlei Power Station:

Road plastic barriers	Solid Barricading
	

CONTROLLED DISCLOSURE

When downloaded from the document management system, this document is uncontrolled and the responsibility rests with the user to ensure it is in line with the authorised version on the system.

No part of this document may be reproduced without the expressed consent of the copyright holder, Eskom Holdings SOC Limited, Reg No 2002/015527/30.

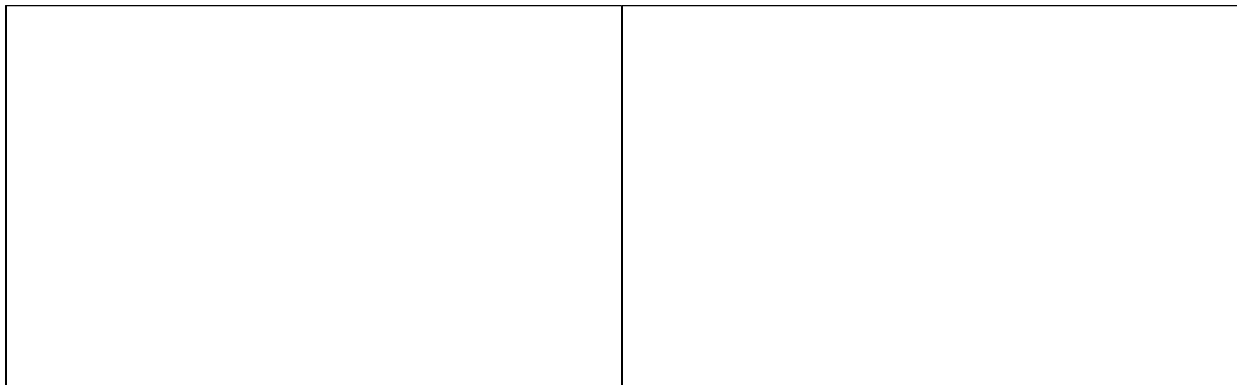

Safety Nets



Welding screen (Hot work barricading)

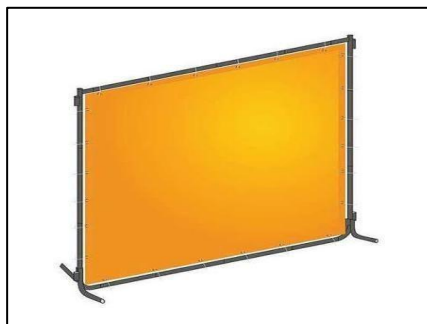

Welding blanket



Prohibited Barricading material:

The danger tape (red and white) is prohibited as the means of barricading. **Only** the emergency team can use this type of barricading in cases of emergency.



When downloaded from the document management system, the user must ensure it is used in accordance with the system. No part of this document may be reproduced without the prior written permission of Eskom Holdings SOC Limited.

and the responsibility rests with the user system. Eskom Holdings SOC Limited, the copyright holder, Eskom Holdings SOC Limited,

Figure 1: Danger Tape

The following requirements needs to be adhered to, at all times:

Barricading shall be fitted with a tag which shall have the following information clearly displayed (See figure 2 below):

- ❖ Name of the department or Contractor Company,
- ❖ Name of the responsible person and contact number, frequency of barricading inspection.
- ❖ A warning sign shall be displayed informing people of the existence of the unsafe conditions.



Figure 2: Barricading Tag

The above information must be clearly attached to the barricade until the activity is completed, and the barricading is safely dismantled.

- Solid barricading should be used for extended activities.
- All safety netting barricades must be supported.
- Under no circumstances must a barricaded area be accessed without the required authorization from the activity supervisor/responsible person. **Unauthorized entry into a barricaded area is a violation of a safety rule and may lead to disciplinary measures.**
- Never modify any constructed solid barricading to suit your own conditions as this is viewed as tempering. Contact the relevant person/s should such a need arise.
- There must be adequate lighting in barricaded areas.

CONTROLLED DISCLOSURE

When downloaded from the document management system, this document is uncontrolled and the responsibility rests with the user to ensure it is in line with the authorised version on the system.

No part of this document may be reproduced without the expressed consent of the copyright holder, Eskom Holdings SOC Limited, Reg No 2002/015527/30.

- Climbing over solid barricading is prohibited and is considered a safety rule violation.
- All barricading should be erected at a sufficient distance away from the hazard to prevent physical contact being made between personnel or equipment and the hazard.
- The Supervisor of the work being conducted is accountable for ensuring that a risk assessment is conducted before the commencement of work and selecting the appropriate controls in relation to temporary barricading where the work will result in a hazard that may affect others.

3.47 CONTRACTOR PERFORMANCE MONITORING

Contractor management is required to do the following as part of the continuous improvement initiatives:

- Visible Felt leadership by top management
- Identify critical tasks and monitor by conducting Job Observations
- Contractor Chief Executive or Managing Director shall present the lost time incidents at Business Unit Power Station General Managers meeting

3.48 CONTRACT SIGN OFF

On completion of the project, all Eskom team must conduct the final audit, inspections, and housekeeping to identify defects, outstanding actions, and open incident cases, and present their findings to the contractor and Eskom contract manager, who must facilitate the closeout. Once the contractor has closed all findings the Eskom's team will verify and sign off prior to issuing a completion certificate and final payment.

3.49 ESKOM'S RIGHT TO TERMINATE THE CONTRACT

The contractor/supplier shall at all times comply with Eskom's occupational health and safety (OHS), legal and other requirements as amended for the duration of the contract. In addition, the contractor shall comply with the requirements contained in the SHE Specification. Eskom reserves the right to terminate the contract in the event that the contractor has built up a history of poor performance or non-conformance in relation to matters of Eskom OHS and legal compliance. No work may commence until the health and safety file has been approved by Eskom OHS personnel.

4. AUTHORIZATION

The OHS Manager & Contracts Manager to authorise, include their names

CONTROLLED DISCLOSURE

When downloaded from the document management system, this document is uncontrolled and the responsibility rests with the user to ensure it is in line with the authorised version on the system.

No part of this document may be reproduced without the expressed consent of the copyright holder, Eskom Holdings SOC Limited, Reg No 2002/015527/30.

5. REVISIONS

Date	Rev.	Remarks
June 2025	1	This provides the initial OHS specification requirements that must be met by the relevant contractors who have been awarded a contract for the work to be performed for Eskom Generation.

6. DEVELOPMENT TEAM APPROVED

CONTROLLED DISCLOSURE

When downloaded from the document management system, this document is uncontrolled and the responsibility rests with the user to ensure it is in line with the authorised version on the system.

No part of this document may be reproduced without the expressed consent of the copyright holder, Eskom Holdings SOC Limited, Reg No 2002/015527/30.