

TENDER DOCUMENT GOODS AND SERVICES		 CITY OF CAPE TOWN ISIXEKO SASEKAPA STAD KAAPSTAD
SUPPLY CHAIN MANAGEMENT		
SCM - 542	Approved by Branch Manager: February 2024	Version: 10

TENDER NO: 241G/2023/24**TENDER DESCRIPTION: SUPPLY AND DELIVERY OF LANDFILL PLANT AND EQUIPMENT****CONTRACT PERIOD: NOT EXCEEDING THIRTY SIX (36) MONTHS FROM THE DATE OF COMMENCEMENT OF CONTRACT**

CLOSING DATE	31 May 2024
CLOSING TIME	10:00 am
TENDER BOX NUMBER	135
TENDER FEE	R200

Non – refundable tender fee payable to the City of Cape Town (CCT) for a hard copy of the tender document. This fee is not applicable to website downloads of the tender document.

TENDERER	
NAME of Company/Close Corporation or Partnership / Joint Venture/ Consortium or Sole Proprietor /Individual (hereinafter the "Tenderer")	
TRADING AS (if different from above)	
Registration number of Tenderer	
Physical address and chosen domicilium citandi et executandi of Tenderer	

NATURE OF TENDER OFFER (please indicate below)	
Main Offer (see clause 2.2.11.1)	
Alternative Offer (see clause 2.2.11.1)	

TENDER SERIAL NO.:
SIGNATURES OF CCT OFFICIALS AT TENDER OPENING
1
2
3

TABLE OF CONTENTS

THE TENDER.....	3
T.1 GENERAL TENDER INFORMATION	3
T.2 CONDITIONS OF TENDER	4
2.1 General.....	4
2.2 Tenderer’s obligations	8
2.3 The CCT’s undertakings.....	14
THE CONTRACT	22
C.1 DETAILS OF TENDERER/SUPPLIER	23
C.2 FORM OF OFFER AND ACCEPTANCE	24
C.2.1 OFFER (TO BE COMPLETED BY THE TENDERER AS PART OF TENDER SUBMISSION).....	24
C.2.2 ACCEPTANCE (TO BE COMPLETED BY THE CCT)	25
C.2.3 SCHEDULE OF DEVIATIONS (TO BE COMPLETED BY THE CCT UPON ACCEPTANCE)	26
C.2.4 CONFIRMATION OF RECEIPT (TO BE COMPLETED BY SUPPLIER UPON ACCEPTANCE).....	27
C.3 OCCUPATIONAL HEALTH AND SAFETY AGREEMENT	28
C.4 PRICE SCHEDULE	29
C.5 SPECIFICATION(S).....	33
C.6 SPECIAL CONDITIONS OF CONTRACT	130
C.7 GENERAL CONDITIONS OF CONTRACT	141
C.8 ANNEXURES	150
ANNEXURE A – PRO FORMA INSURANCE BROKER’S WARRANTY	150
ANNEXURE B – MONTHLY PROJECT LABOUR REPORT	151
ANNEXURE C - PRO FORMA PERFORMANCE SECURITY/ GUARANTEE	153
ANNEXURE D - PRO FORMA ADVANCE PAYMENT GUARANTEE	154
ANNEXURE F - TENDER RETURNABLE DOCUMENTS.....	155
<i>Schedule F.1: Contract Price Adjustment</i>	<i>155</i>
<i>Schedule F.2: Certificate of Authority for Partnerships/ Joint Ventures/ Consortiums</i>	<i>173</i>
<i>Schedule F.3: Declaration for Procurement above R10 million</i>	<i>174</i>
<i>Schedule F.4: Preference Points Claim Form In Terms Of the Preferential Procurement Regulations 2022</i>	<i>175</i>
<i>Schedule F.5: Declaration of Interest – State Employees (MBD 4 amended).....</i>	<i>178</i>
<i>Schedule F.6: Conflict of Interest Declaration</i>	<i>180</i>
<i>Schedule F.7: Declaration of Tenderer’s Past Supply Chain Management Practices (MBD 8).....</i>	<i>181</i>
<i>Schedule F.8: Authorisation for the Deduction of Outstanding Amounts Owed to the CCT</i>	<i>183</i>
<i>Schedule F.9: Certificate of Independent Tender Determination</i>	<i>184</i>
<i>Schedule F.10: Proposed Deviations And Qualifications By Tenderer</i>	<i>185</i>
<i>Schedule F.11: List of Other Documents Attached By Tenderer.....</i>	<i>186</i>
<i>Schedule F.12: Record of Addenda to Tender Documents</i>	<i>187</i>
<i>Schedule F.13: Information to Be Provided With the Tender.....</i>	<i>188</i>
<i>Schedule F.14: Appeal Application.....</i>	<i>189</i>

THE TENDER

T.1 GENERAL TENDER INFORMATION

TENDER ADVERTISED	:	26 April 2024
SITE VISIT/CLARIFICATION MEETING	:	https://meet.capetown.gov.za/bongiwe.madlingozi/K6TY
		<u>S00D</u>
		(Not compulsory, but strongly recommended)
VENUE FOR SITE VISIT/CLARIFICATION MEETING	:	Skype
TENDER BOX & ADDRESS	:	Tender Box as per front cover at the Tender & Quotation Boxes Office, 2nd Floor (Concourse Level), Civic Centre, 12 Hertzog Boulevard, Cape Town.
	:	The Tender Document (which includes the Form of Offer and Acceptance) completed in all respects, plus any additional supporting documents required, must be submitted in a sealed envelope with the name and address of the tenderer, the endorsement “TENDER NO. 241G/2023/24: Supply and Delivery of Landfill Plant and Equipment , the tender box No. and the closing date indicated on the envelope. The sealed envelope must be inserted into the appropriate official tender box before closing time.
		If the tender offer is too large to fit into the abovementioned box or the box is full, please enquire at the public counter (Tender Distribution Office) for alternative instructions. It remains the tenderer’s responsibility to ensure that the tender is placed in either the original box or as alternatively instructed.
CCT TENDER REPRESENTATIVE		Name: Bongive Madlingozi Tel. No.: (021) 444 6980 Email: bongiwe.madlingozi@capetown.gov.za
		OR
		Name: Xolani Mbane Tel. No.: (021) 444 6981 Email: xolani.mbane@capetown.gov.za

TENDERERS MUST NOTE THAT WHEREVER THIS DOCUMENT REFERS TO ANY PARTICULAR TRADE MARK, NAME, PATENT, DESIGN, TYPE, SPECIFIC ORIGIN OR PRODUCER, SUCH REFERENCE SHALL BE DEEMED TO BE ACCOMPANIED BY THE WORDS “OR EQUIVALENT”

T.2 CONDITIONS OF TENDER

2.1 General

2.1.1 Actions

2.1.1.1 The City of Cape Town (hereafter referred to as the "CCT") and each tenderer submitting a tender offer (hereinafter referred to as the "tenderer" or the "supplier") shall comply with item T.2 of this Tender Document Goods and Services (hereinafter referred to as these "Conditions of Tender"). The tenderer and the CCT shall collectively hereinafter be referred to as the "Parties" and individually a "Party"). In their dealings with each other, the Parties shall discharge their duties and obligations as set out in these Conditions of Tender, timeously and with integrity, and behave equitably, honestly and transparently, and shall comply with all legal obligations imposed on the Parties herein and in accordance with all applicable laws.

The Parties agree that this tender Tender Document Goods and Services (hereinafter referred to as the "Tender" / "Tender Document"), its evaluation and acceptance and any resulting contract shall also be subject to the CCT's Supply Chain Management Policy ("SCM Policy") that was applicable on the date the bid was advertised and as amended from time to time. If the CCT adopts a new SCM Policy which contemplates that any clause therein would apply to the Contract emanating from this tender (hereinafter referred to as the "Contract"), such clause shall also be applicable to that Contract. Please refer to this document contained on the CCT's website.

Abuse of the supply chain management system is not permitted and may result, inter alia, (1) in the tender being rejected; (2) cancellation of the contract; (3) restriction of the supplier, and/or (4) the exercise by the CCT of any other remedies available to it as provided for in the SCM Policy and/or the the Contract and/or this tender and/or any applicable laws .

2.1.1.2 The CCT, the tenderer and their agents and employees involved in the tender process shall avoid conflicts of interest and where a conflict of interest is perceived or known, declare any such conflict of interest, indicating the nature of such conflict. Tenderers shall declare any potential conflict of interest in their tender submissions. Employees, agents and advisors of the CCT shall declare any conflict of interest to the CCT at the start of any deliberations relating to the procurement process or as soon as they become aware of such conflict, and abstain from any decisions where such conflict exists or recuse themselves from the procurement process, as appropriate.

2.1.1.3 The CCT shall not seek, and a tenderer shall not submit a tender, without having a firm intention and capacity to proceed with the contract.

2.1.2 Interpretation

2.1.2.1 The additional requirements contained in Annexure F to the contract (hereinafter referred to as the "returnable documents" / "Returnable Schedules") are part of these Conditions of Tender and are specifically hereby incorporated into these Conditions of Tender.

2.1.2.2 These Conditions of Tender and returnable Documents which are required for CCT's tender evaluation purposes herein, shall form part of the Contract arising from the CCT's corresponding invitation to tender.

2.1.3 Communication during tender process

Verbal or any other form of communication, from the CCT, its employees, agents or advisors during site visits/clarification meetings or at any other time prior to the award of the Contract, will not be regarded as binding on the CCT, unless communicated by the CCT in writing to suppliers / tenderers by its Director: Supply Chain Management or his nominee. Similarly, any communication of the tenderer / supplier that is not reduced to writing by the tenderer / supplier, its employees, agents or advisors, shall not be regarded as binding on the CCT, unless communicated to the CCT in writing by the suppliers / tenderers, or their duly authorised representatives.

2.1.4 The CCT's right to accept or reject any tender offer

2.1.4.1 The CCT may accept or reject any tender offer and may cancel the corresponding tender process or reject all tender offers at any time before the formation of a contract. The CCT may, prior to the award of the tender, cancel a tender if:

- (a) due to changed circumstances, there is no longer a need for the services, works or goods requested;
or
- (b) funds are no longer available to cover the total envisaged expenditure; or
- (c) no acceptable tenders are received;
- (d) there is a material irregularity in the tender process; or
- (e) the Parties are unable to negotiate market related pricing.

The CCT shall not accept or incur any liability to a tenderer for such cancellation or rejection, but will give written reasons for such action upon receiving a written request to do so.

2.1.5 Procurement procedures

2.1.5.1 General

Unless otherwise stated in the Conditions of Tender, a contract will be concluded with the tenderer who scores the highest number of tender adjudication points.

Unless otherwise stated in the tender conditions, a contract will be concluded with the tenderer who scores the highest number of tender adjudication points.

The CCT intends to appoint two tenderers (the highest ranked tenderer ("the winner") and in addition "alternative tenderers") or the allocation of work. If insufficient responsive bids are received, the CCT reserves the right to appoint fewer tenderers, or not to appoint any tenderers at all.

Suppliers, once appointed and subject to operational requirements, will be invited to deliver the goods or services on a "winner-takes-all" basis, whereby the order will always be offered and, if accepted, allocated to the highest ranked tenderer ("the winner"), and only if he refuses will the work be offered to the next highest ranked tenderer from the alternative tenderers).

The contract period shall be for a period of **Thirty-six 36 months** from the commencement date of the contract.

2.1.5.2 Proposal procedure using the two stage-system

A two-stage system will not be followed.

2.1.5.2.1 Tenderers shall submit in the first stage only technical proposals. The CCT shall invite all responsive tenderers to submit tender offers in the second stage, following the issuing of applicable procurement documents.

2.1.5.2.2 The CCT shall evaluate tenders received during the second stage in terms of the method of evaluation stated in the Conditions of Tender, and award the contract in terms of these Conditions of Tender.

2.1.5.3 Nomination of Standby Bidder

"Standby Bidder" means a bidder, identified by the CCT at the time of awarding a bid that will be considered for award should the contract be terminated for any reason whatsoever. In the event that a contract is terminated during the execution thereof, the CCT may consider the award of the contract, or non-award, to the Standby Bidder in terms of the procedures included its SCM Policy, as amended from time to time.

2.1.6 Objections, complaints, queries and disputes/ Appeals in terms of Section 62 of the Systems Act/ Access to court

2.1.6.1 Disputes, objections, complaints and queries

In terms of Regulations 49 and 50 of the Local Government: Municipal Finance Management Act, 56 of 2003 Municipal Supply Chain Management Regulations (Board Notice 868 of 2005):

- a) Persons aggrieved by decisions or actions taken by the CCT in the implementation of its supply chain management system, may lodge within 14 days of the decision or action, a written objection or complaint or query or dispute against the decision or action.

2.1.6.2 Appeals

- a) In terms of Section 62 of the Local Government: Municipal Systems Act, 32 of 2000 a person whose rights are affected by a decision taken by the CCT, may appeal against that decision by giving written notice of the appeal and reasons to the City Manager within 21 days of the date of the notification of the decision.
- b) An appeal must contain the following:
- i. Must be in writing
 - ii. It must set out the reasons for the appeal
 - iii. It must state in which way the Appellant's rights were affected by the decision;
 - iv. It must state the remedy sought; and
 - v. It must be accompanied with a copy of the notification advising the person of the decision
- c) The relevant CCT appeal authority must consider the appeal and **may confirm, vary or revoke** the decision that has been appealed, but no such revocation of a decision may detract from any rights that may have accrued as a result of the decision.

2.1.6.3 Right to approach the courts and rights in terms of Promotion of Administrative Justice Act, 3 of 2000 and Promotion of Access to Information Act, 2 of 2000

The sub- clauses above do not influence any affected person's rights to approach the High Court at any time or its rights in terms of the Promotion of Administrative Justice Act (PAJA) and Promotion of Access to Information Act (PAIA).

- 2.1.6.4** All requests referring to sub clauses 2.1.6.1 and 2.1.6.2 must be submitted in writing to:
The City Manager - C/o the Manager: Legal Compliance Unit, Legal Services Department, Office of the City Manager
Via hand delivery at: 20th Floor, Tower Block, 12 Hertzog Boulevard, Cape Town 8001
Via post at: Private Bag X918, Cape Town, 8000
Via email at: MSA.Appeals@capetown.gov.za

- 2.1.6.5** All requests referring to clause 2.1.6.3 must be submitted in writing to:
The City Manager - C/o the Manager: Access to Information Unit, Legal Service Department, Office of the City Manager
Via hand delivery at: 20th Floor, Tower Block, 12 Hertzog Boulevard, Cape Town 8001
Via post at: Private Bag X918, Cape Town, 8000
Via email at: Access2info.Act@capetown.gov.za

2.1.6.6 The minimum standards regarding accessing and 'processing' of any personal information belonging to another in terms of Protection of Personal Information Act, 2013 (POPIA).

For purposes of this clause 2.1.6.6, the contract and these Conditions of Tender, the terms "data subject", "Personal Information" and "Processing" shall have the meaning as set out in section 1 of POPIA, and "Process" shall have the corresponding meaning.

The CCT, its employees, representatives and sub-contractors may, from time to time, Process the tenderer's and/or its employees', representatives' and/or sub-contractors' Personal Information, for purposes of, and/or relating to, the tender, the contract and these Conditions of Tender, for research purposes, and/or as otherwise may be envisaged in the CCT's Privacy Notice and/or in relation to the CCT's Supply Chain Management Policy or as may be otherwise permitted by law. This includes the Processing of the latter Personal Information by the CCT's due diligence assurance provider, professional advisors and the Appeal Authority as applicable. The CCT's justification for the processing of such aforesaid Personal Information is based on section 11(1)(b) of POPIA, i.e., in terms of which the CCT's Processing of the said Personal Information is necessary to carry out actions for the conclusion and/or performance of the contract, to which the applicable data subject (envisaged in

this clause 2.1.6.6 above) is a party.

All requests relating to data protection must be submitted in writing to:
The City Manager - C/o the Information Officer, Office of the City Manager
Via hand delivery at: 20th Floor, Tower Block, 12 Hertzog Boulevard, Cape Town 8001
Via post at: Private Bag X9181, Cape Town, 8000
Via email at: Popia@capetown.gov.za.

2.1.6.7 Compliance to the CCTs Appeals Policy.

In terms of the CCT's Appeals Policy, a fixed upfront administration fee will be charged. In addition, a surcharge may be imposed for vexatious and frivolous or otherwise manifestly inappropriate tender related appeals.

The current approved administration fee is R300.00 and may be paid at any of the Municipal Offices or at the Civic Centre in Cape Town using the GL Data Capture Receipt attached as Annexure F.13: Appeal Application Form. Alternatively, via EFT into the CCT's NEDBANK Account: CITY OF CAPE TOWN and using Reference number: 198158966. You are required to send proof of payment when lodging your appeal.

The current surcharge for vexatious and frivolous or otherwise manifestly inappropriate tender related appeals will be calculated as $\frac{1}{2}$ (Administrative cost of the tender appeal) + 0.25 % (Appellant's tender price).

Should the payment of the administration fee of R300.00 or the surcharge not be received, such fee or surcharge will be added as a Sundry Tariff to the bidder's municipal account.

In the event where the bidder does not have a Municipal account with the CCT, the fee or surcharge may be recovered in terms of the CCT's Credit Control and Debt Collection By-law, 2006 (as amended) and its Credit Control and Debt Collection Policy.

2.1.7 CCT Supplier Database Registration

Tenderers are required to be registered on the CCT Supplier Database as a service provider. Tenderers must register as such upon being requested to do so in writing and within the period contained in such a request, failing which no orders can be raised or payments processed from the resulting contract. In the case of Joint Venture partnerships this requirement will apply individually to each party of the Joint Venture.

Tenderers who wish to register on the CCT's Supplier Database may collect registration forms from the Supplier Management Unit located within the Supplier Management / Registration Office, 2nd Floor (Concourse Level), Civic Centre, 12 Hertzog Boulevard, Cape Town (Tel 021 400 9242/3/4/5). Registration forms and related information are also available on the CCT's website www.capetown.gov.za (follow the Supply Chain Management link to Supplier registration).

It is each tenderer's responsibility to keep all the information on the CCT Supplier Database updated.

2.1.8 National Treasury Web Based Central Supplier Database (CSD) Registration

Tenderers are required to be registered on the National Treasury Web Based Central Supplier Database (CSD) as a service provider. Tenderers must register as such upon being requested to do so in writing and within the period contained in such a request, failing which no orders can be raised or payments processed from the resulting contract. In the case of Joint Venture partnerships this requirement will apply individually to each party of the Joint Venture.

Tenderers who wish to register on the National Treasury Web Based Central Supplier Database (CSD) may do so via the web address <https://secure.csd.gov.za>.

It is each tenderer's responsibility to keep all the information on the National Treasury Web Based Central Supplier Database (CSD) updated.

2.2 Tenderer's obligations

2.2.1 Eligibility Criteria

2.2.1.1 Tenderers are obligated to submit a tender offer that complies in all aspects to the conditions as detailed in this tender document and the Conditions of Tender. An 'acceptable tender must "COMPLY IN ALL" aspects with the tender, Conditions of Tender, all Specifications (i.e., item C.5 below, hereinafter the "Specifications"), pricing instructions herein and the Contract including its conditions.

2.2.1.1.1 Submit a tender offer

Only those tender submissions from which it can be established, *inter alia* that a clear, irrevocable and unambiguous offer has been made to CCT, by whom the offer has been made and what the offer constitutes, will be declared responsive.

2.2.1.1.2 Compliance with requirements of CCT SCM Policy and procedures

Only those tenders that are compliant with the requirements below will be declared responsive:

- a) A completed **Details of Tenderer** to be provided (applicable schedule below to be completed);
- b) A completed **Certificate of Authority for Partnerships/ Joint Ventures/ Consortiums** to be provided authorising the tender to be made and the signatory to sign the tender on the partnership /joint venture/consortium's (applicable schedule below to be completed);
- c) A copy of the partnership / joint venture / consortium agreement to be provided, where applicable.
- d) A completed **Declaration of Interest – State Employees** to be provided and which does not indicate any non-compliance with the legal requirements relating to state employees (applicable schedule below to be completed);
- e) A completed **Declaration – Conflict of Interest and Declaration of Bidders' past Supply Chain Management Practices** to be provided and which does not indicate any conflict or past practises that renders the tender non-responsive based on the conditions contained thereon (applicable schedules below to be completed);
- f) A completed **Certificate of Independent Bid Determination** to be provided and which does not indicate any non-compliance with the requirements of the schedule (applicable schedule below to be completed);
- g) The tenderer (including any of its representatives, directors or members), has not been restricted in terms of abuse of the Supply Chain Management Policy,
- h) The tenderer's tax matters with SARS are in order, or the tenderer is a foreign supplier that is not required to be registered for tax compliance with SARS;
- i) The tenderer is not an advisor or consultant contracted with the CCT whose prior or current obligations creates any conflict of interest or unfair advantage;
- j) The tenderer is not a person, advisor, corporate entity or a director of such corporate entity, who is directly or indirectly involved or associated with the bid specification committee;
- k) A completed **Authorisation for the Deduction of Outstanding Amounts Owed to the CCT** to be provided and which does not indicate any details that renders the tender non-responsive based on the conditions contained thereon (applicable schedules below to be completed);
- l) The tenderer (including any of its representatives, directors or members), has not been found guilty of contravening the Competition Act 89 of 1998, as amended from time to time;
- m) The tenderer (including any of its representatives, directors or members), has not been found guilty on any other basis listed in the Supply Chain Management Policy.

2.2.1.1.3 Compulsory clarification meeting

NOT APPLICABLE

2.2.1.1.4 Minimum score for functionality

NOT APPLICABLE

2.2.1.1.7 Provision of samples

NOT APPLICABLE

2.2.1.1.8. TECHNICAL BROCHURE/DATA SHEET

Tenderers must submit a brochure with technical information on their tendered product. The technical brochure must be for the proposed make and model and there should be no discrepancy between the technical brochure and make and model of the machine offered.

2.2.1.1.9. TECHNICAL SPECIFICATION SCHEDULE

Tenderer to complete the C.5 Technical Specification in full (including referencing the relevant page numbers on the brochures to correspond with the items on C.5 Specification).

2.2.1.1.10 OEM CONFIRMATION EARTHMOVING PLANT/EQUIPMENT DISTRIBUTOR

The tenderer shall supply documentary proof that they are registered as a motor dealer/manufacturer in terms of the National Road Traffic Act of 1996 in the form of a Business Registration Number certificate (BRNC) or must provide via a covering letter an OEM confirmation that they are approved as an earthmoving plant/equipment distributor and will provide parts and maintenance of the equipment.

2.2.1.1.11 OEM APPROVED WORKSHOP FACILITIES

The tenderers must submit a confirmation letter from the Original Equipment Manufacturer (OEM) stating that the workshop facilities offered are OEM approved for the maintenance, repair, testing and major overhauls of the machine offered while under warranty. The location of the proposed service facility and a contact name shall be supplied. Refer to Clause 36 of the Special Condition of Contract for the establishment of workshop within the geographical boundaries of the City of Cape Town.

Failure to provide above mentioned documents will render the bid non-responsive

2.2.2 Cost of tendering

The CCT will not be liable for any costs incurred in the preparation and submission of a tender offer, including the costs of any testing necessary to demonstrate that aspects of the offer complies with requirements.

2.2.3 Check documents

The documents issued by the CCT for the purpose of a tender offer are listed in the index of this tender document.

Before submission of any tender, the tenderer should check the number of pages, and if any are found to be missing or duplicated, or the figures or writing is indistinct, or if the Price Schedule contains any obvious errors, the tenderer must apply to the CCT at once to have the same rectified.

2.2.4 Confidentiality and copyright of documents

The tenderer shall treat as strictly confidential all matters arising in connection with the tender. Use and copy the documents issued by the CCT only for the purpose of preparing and submitting a tender offer in response to the invitation.

2.2.5 Reference documents

The tenderer shall obtain, as necessary for submitting a tender offer, copies of the latest versions of standards, specifications, Conditions of Contract and other publications, which are not attached but which are incorporated into the tender document(s) by reference.

2.2.6 Acknowledge and comply with notices

The tenderer shall acknowledge receipt of notices to the tender documents, which the CCT may issue, and shall fully comply with all instructions issued in the said notices, and if necessary, apply for an extension of the closing time stated on the front page of the tender document, in order to take the notices into account. Notwithstanding any requests for confirmation of receipt of the said notices issued, the tenderer shall be deemed to have received such notices if the CCT can show proof of transmission thereof via electronic mail, facsimile, or registered post or other lawful means.

2.2.7 Clarification meeting

The tenderer shall attend, where required, a clarification meeting at which tenderers may familiarise themselves with aspects of the proposed work, services or supply and pose questions. Details of the meeting(s) are stated in the General Tender Information (i.e., in item T.1 above).

Tenderers should be represented at the site visit/clarification meeting by a duly authorised person who is suitably qualified and experienced to comprehend the implications of the work involved.

2.2.8 Seek clarification

The tenderer shall request clarification of the tender documents, if necessary, by notifying the CCT at least one week before the closing time stated in the General Tender Information (i.e., in item T.1 above), where possible.

2.2.9 Pricing the tender offer

2.2.9.1 The tenderer shall comply with all pricing instructions as stated on the Price Schedule.

2.2.10 Alterations to documents

The tenderer shall not make any alterations or additions to the tender documents, except to comply with instructions issued by the CCT in writing, or necessary to correct errors made by the tenderer. All signatories to the tender offer shall initial all such alterations.

2.2.11 Alternative tender offers

2.2.11.1 Unless otherwise stated in the Conditions of Tender, the tenderers may submit alternative tender offers only if a main tender offer, strictly in accordance with all the requirements of the tender documents, is also submitted.

If a tenderer wishes to submit an alternative tender offer, he/she/it shall do so as a separate offer on a complete set of tender documents. The alternative tender offer shall be submitted in a separate sealed envelope clearly marked "Alternative Tender" in order to distinguish it from the main tender offer.

Only the alternative of the highest ranked acceptable main tender offer (that is, submitted by the same tenderer) will be considered, and if appropriate, recommended for award.

Alternative tender offers of any but the highest ranked main tender offer will not be considered.

An alternative tender offer to the highest ranked acceptable main tender offer that is priced higher than the main tender offer may be recommended for award, provided that the ranking of the alternative tender offer is higher than the ranking of the next ranked acceptable main tender offer.

The CCT will not be bound to consider alternative tenders and shall have sole discretion in this regard.

In the event that the alternative is accepted, the tenderer warrants that the alternative offer complies in all respects with the CCT's standards and requirements as set out in the tender document.

2.2.11.2 Acceptance of an alternative tender offer by the CCT may be based only on the criteria stated in the Conditions of Tender or applicable criteria otherwise acceptable to the CCT.

2.2.12 Submitting a tender offer

2.2.12.1 The tenderer is required to submit one tender offer only on the original tender documents as issued by the CCT, either as a single tendering entity or as a member in a joint venture to provide the whole of the works, services or supply identified in the Conditions of Contract and described in the Specifications. Only those tenders submitted on the tender documents as issued by the CCT together with all Tender Returnable Documents duly completed and signed will be declared responsive.

2.2.12.2 The tenderer shall return the entire tender document to the CCT after completing it in its entirety, either electronically (if they were issued in electronic format) or by writing legibly in non-erasable ink.

2.2.12.3 The tenderer shall sign the original tender offer where required in terms of the Conditions of Tender. The tender shall be signed by a person duly authorised by the tenderer to do so. Tenders submitted by joint ventures of two or more firms shall be accompanied by the document of formation / founding document of the joint venture or any other document signed by all Parties, in which is defined precisely the conditions under which the joint venture will function, its period of duration, the persons authorised to represent and obligate it, the participation of the several firms forming the joint venture, and any other information necessary to permit a full appraisal of its functioning. Signatories for tenderers proposing to contract as joint ventures shall state which of the signatories is the lead partner.

2.2.12.4 Where a two-envelope system is required in terms of the Conditions of Tender, place and seal the returnable documents listed in the Conditions of Tender in an envelope marked "financial proposal" and place the remaining returnable documents in an envelope marked "technical proposal". Each envelope shall state on the outside the CCT's address and identification details stated in the General Tender Information (i.e., item T.1 above), as well as the tenderer's name and contact address.

2.2.12.5 The tenderer shall seal the original tender offer and copy packages together in an outer package that states on the outside only the CCT's address and identification details as stated in the General Tender Information. . If it is not possible to submit the original tender and the required copies (see 2.2.12.3) in a single envelope, then the tenderer must seal the original and each copy of the tender offer as separate packages marking the packages as "ORIGINAL" and "COPY" in addition to the aforementioned tender submission details.

2.2.12.6 The CCT shall not assume any responsibility for the misplacement or premature opening of the tender offer if the outer package is not sealed and marked as stated.

2.2.12.7 Tender offers submitted by facsimile or e-mail will be rejected by the CCT, unless stated otherwise in the Conditions of Tender.

2.2.12.8 By signing the offer part of the Form of Offer (**Section 5, Part A hereto**) the tenderer warrants and agrees that all information provided in the tender submission is true and correct.

2.2.12.9 Tenderers shall properly deposit its bid in the designated tender box (as detailed on the front page of this tender document) on or before the closing date and before the closing time, in the relevant tender box at the Tender & Quotation Boxes Office situated on the 2nd floor, Concourse Level, Civic Centre, 12 Hertzog Boulevard, Cape Town. If the tender submission is too large to fit in the allocated box, please enquire at the public counter for assistance.

2.2.12.10 The tenderer must record and reference all information submitted contained in other documents for example cover letters, brochures, catalogues, etc. in the Returnable Schedule titled **List of Other Documents Attached by Tenderer**.

2.2.13 Information and data to be completed in all respects

Tender offers, which do not provide all the data or information requested completely and in the form required, may be regarded by the CCT as non-responsive.

2.2.14 Closing time

2.2.14.1 The tenderer shall ensure that the CCT receives the tender offer, together with all applicable documents specified herein, at the address specified in the General Tender Information herein prior to the closing time stated on the front page of the tender document.

2.2.14.2 If the CCT extends the closing time stated on the front page of the tender document for any reason, the requirements of these Conditions of Tender apply equally to the extended deadline.

2.2.14.3 The CCT shall not consider tenders that are received after the closing date and time for such a tender (late tenders).

2.2.15 Tender offer validity and withdrawal of tenders

2.2.15.1 The tenderer shall warrant that the tender offer(s) remains valid, irrevocable and open for acceptance by the CCT at any time for a period of 120 days after the closing date stated on the front page of the tender document.

2.2.15.2 Notwithstanding the period stated in clause 2.2.15.1 above, bids shall remain valid for acceptance for a period of twelve (12) months after the expiry of the original validity period, unless the CCT is notified in writing of anything to the contrary by the bidder. The validity of bids may be further extended by a period of not more than six months subject to mutual agreement by the parties, administrative processes and upon approval by the City Manager, unless the required extension is as a result of an appeal process or court ruling.

In circumstances where the validity period of a tender has expired, and the tender has not been awarded, the tender process is considered "completed", despite there being no decision (award or cancellation) made. This anomaly does not fall under any of the listed grounds of cancellation and should be treated as a "non award". A "non award" is supported as a recommendation to the CCT's Bod Adjudication Committee ("BAC") for noting.

2.2.15.3 A tenderer may request in writing, after the closing date, that its tender offer be withdrawn. Such withdrawal will be permitted or refused at the sole discretion of the CCT after consideration of the reasons for the withdrawal, which shall be fully set out by the tenderer in such written request for withdrawal. Should the tender offer be withdrawn in contravention hereof, the tenderer agrees that:

- a) it shall be liable to the CCT for any additional expense incurred or losses suffered by the CCT in having either to accept another tender or, if new tenders have to be invited, the additional expenses incurred or losses suffered by the invitation of new tenders and the subsequent acceptance of any other tender;
- b) the CCT shall also have the right to recover such additional expenses or losses by set-off against monies which may be due or become due to the tenderer under this or any other tender or contract or against any guarantee or deposit that may have been furnished by the tenderer or on its behalf for the due fulfilment of this or any other tender or contract. Pending the ascertainment of the amount of such additional expenses or losses, the CCT shall be entitled to retain such monies, guarantee or deposit as security for any such expenses or loss, without prejudice to the CCT's other rights and/or remedies available to it in accordance with any applicable laws.

2.2.16 Clarification of tender offer, or additional information, after submission

Tenderer's shall promptly provide clarification of its tender offer, or additional information, in response to a written request to do so from the CCT during the evaluation of tender offers within the time period stated in such request. No change in the competitive position of tenderers or substance of the tender offer is sought, offered, or permitted.

Note: This clause does not preclude the negotiation of the final terms of the contract with a preferred tenderer following a competitive selection process, should the CCT elect to do so.

Failure, or refusal, to provide such clarification or additional information within the time for submission stated

in the CCT's written request may render the tender non-responsive.

2.2.17 Provide other material

2.2.17.1 Tenderer's shall promptly provide, upon request by the CCT, any other material that has a bearing on the tender offer, the tenderer's commercial position (including joint venture agreements), preferencing arrangements, or samples of materials, considered necessary by the CCT for the purpose of the evaluation of the tender. Should the tenderer not provide the material, or a satisfactory reason as to why it cannot be provided, by the time for submission stated in the CCT's request, the CCT may regard the tender offer as non-responsive.

2.2.17.2 The tenderer shall provide, on written request by the CCT, where the transaction value inclusive of VAT **exceeds R 10 million**:

- a) audited annual financial statement for the past 3 years, or for the period since establishment if established during the past 3 years, if required by law to prepare annual financial statements for auditing;
- b) a certificate signed by the tenderer certifying that the tenderer has no undisputed commitments for municipal services towards a municipality or other service provider in respect of which payment is overdue for more than 30 days;
- c) particulars of any contracts awarded to the tenderer by an organ of state during the past five years, including particulars of any material non-compliance or dispute concerning the execution of such contract;
- d) a statement indicating whether any portion of the goods or services are expected to be sourced from outside the Republic, and, if so, what portion and whether any portion of payment from the municipality or municipal entity is expected to be transferred out of the Republic.

Each entity to a Consortium/Joint Venture bid shall submit separate certificates/statements in the above regard.

2.2.17.3 Tenderers shall be required to undertake to fully cooperate with the CCT's external service provider appointed to perform a due diligence review and risk assessment upon receipt of such written instruction from the CCT.

2.2.18 Samples, Inspections, tests and analysis

Tenderers shall provide access during working hours to premises for inspections, tests and analysis as provided for in the Conditions of Tender or Specifications.

If the Specifications requires the tenderer to provide samples, these shall be provided strictly in accordance with the instructions set out in the Specification.

If such samples are not submitted as required in the bid documents or within any further time stipulated by the CCT in writing, then the bid concerned may be declared non-responsive.

The samples provided by all successful bidders will be retained by the CCT for the duration of any subsequent contract. Bidders are to note that samples are requested for testing purposes therefore samples submitted to the CCT may not in all instances be returned in the same state of supply and in other instances may not be returned at all. Unsuccessful bidders will be advised by the Project Manager or dedicated CCT Official to collect their samples, save in the aforementioned instances where the samples would not be returned.

2.2.19 Certificates

The tenderer must provide the CCT with all certificates as stated below:

2.2.19.1. Preference Points for Specific Goals

In order to qualify for preference points for HDI and/or Specific Goals, it is the responsibility of the tenderer to submit documentary proof (Company registration certification, Central Supplier Database report, BBBEE certificate, Proof of Disability, Financial Statements, commissioned sworn affidavits, etc.) in support of tenderer claims for such preference for that specific goal.

Tenderers are further referred to the content of the Preference Schedule for the full terms and conditions applicable to the awarding of preference points.

2.2.19.2 Evidence of tax compliance

Tenderers shall be registered with the South African Revenue Service (SARS) and their tax affairs must be in order and they must be tax compliant subject to the requirements of clause 2.2.1.1.2.h. In this regard, it is the responsibility of the Tenderer to submit evidence in the form of a valid Tax Compliance Status PIN issued by SARS to the CCT at the Supplier Management Unit located within the Supplier Management / Registration Office, 2nd Floor (Concourse Level), Civic Centre, 12 Hertzog Boulevard, Cape Town (Tel 021 400 9242/3/4/5), or included with this tender. The tenderer must record its Tax Compliance Status PIN number on the **Details of Tenderer** pages of the tender submission.

Each party to a Consortium/Joint Venture shall submit a separate Tax Compliance Status Pin.

Before making an award the CCT must verify the bidder's tax compliance status. Where the recommended bidder is not tax compliant, the bidder should be notified of the non-compliant status and be requested to submit to the CCT, within 7 working days, written proof from SARS that they have made arrangement to meet their outstanding tax obligations. The proof of tax compliance submitted by the bidder must be verified by the CCT via CSD or e-Filing. The CCT should reject a bid submitted by the bidder if such bidder fails to provide proof of tax compliance within the timeframe stated herein.

Only foreign suppliers who have answered "NO" to all the questions contained in the Questionnaire to Bidding Foreign Suppliers section on the **Details of Tenderer** pages of the tender submission, are not required to register for a tax compliance status with SARS.

2.2.20 Compliance with Occupational Health and Safety Act, 85 of 1993

Tenderers are to note the requirements of the Occupational Health and Safety Act, 85 of 1993. The Tenderer shall be deemed to have read and fully understood the requirements of the above Act and Regulations and to have allowed for all costs in compliance therewith.

In this regard the Tenderer shall submit **upon written request to do so by the CCT**, a Health and Safety Plan in sufficient detail to demonstrate the necessary competencies and resources to deliver the goods or services all in accordance with the Act, Regulations and Health and Safety Specification.

2.2.21 Claims arising from submission of tender

By responding to the tender herein, the tenderer warrants that it has:

- a) Inspected the Specifications and read and fully understood the Conditions of Contract.
- b) Read and fully understood the whole text of the Specifications and Price Schedule and thoroughly acquainted himself with the nature of the goods or services proposed and generally of all matters which may influence the Contract.
- c) visited the site(s) where delivery of the proposed goods will take place, carefully examined existing conditions, the means of access to the site(s), the conditions under which the delivery is to be made, and acquainted himself with any limitations or restrictions that may be imposed by the Municipal or other Authorities in regard to access and transport of materials, plant and equipment to and from the site(s) and made the necessary provisions for any additional costs involved thereby.
- d) requested the CCT to clarify the actual requirements of anything in the Specifications and Price Schedule, the exact meaning or interpretation of which is not clearly intelligible to the Tenderer.
- e) Received any notices to the tender documents which have been issued in accordance with the CCT's Supply Chain Management Policy.

The CCT will therefore not be liable for the payment of any extra costs or claims arising from the submission of the tender.

2.3 The CCT's undertakings

2.3.1 Respond to requests from the tenderer

2.3.1.1 Unless otherwise stated in the Conditions of Tender, the CCT shall respond to a request for clarification received up to one week (where possible) before the tender closing time stated on the front page of the tender document.

2.3.1.2 The CCT's duly authorised representative for the purpose of this tender is stated on the General Tender Information page above.

2.3.2 Issue Notices

If necessary, the CCT may issue addenda in writing that may amend or amplify the tender documents to each tenderer during the period from the date the tender documents are available until one week before the tender closing time stated in the Tender Data. The CCT reserves its rights to issue addenda less than one week before the tender closing time in exceptional circumstances. If, as a result a tenderer applies for an extension to the closing time stated on the front page of the tender document, the CCT may grant such extension and, shall then notify all tenderers who drew documents.

Notwithstanding any requests for confirmation of receipt of notices issued, the tenderer shall be deemed to have received such notices if the CCT can show proof of transmission thereof via electronic mail, facsimile or registered post.

2.3.3 Opening of tender submissions

2.3.3.1 Unless the two-envelope system is to be followed, CCT shall open tender submissions in the presence of tenderers' agents who choose to attend at the time and place stated in the Conditions of Tender.

Tenders will be opened immediately after the closing time for receipt of tenders as stated on the front page of the tender document, or as stated in any Notice extending the closing date and at the closing venue as stated in the General Tender Information.

2.3.3.2 Announce at the meeting held immediately after the opening of tender submissions, at the closing venue as stated in the General Tender Information, the name of each tenderer whose tender offer is opened and, where possible, the prices indicated.

2.3.3.3 Make available a record of the details announced at the tender opening meeting on the CCT's website (<http://www.capetown.gov.za/en/SupplyChainManagement/Pages/default.aspx>.)

2.3.4 two-envelope system

2.3.4.1 Where stated in the Conditions of Tender that a two-envelope system is to be followed, the CCT shall open only the technical proposal of tenders in the presence of tenderers' agents who choose to attend at the time and place stated in the Conditions of Tender and announce the name of each tenderer whose technical proposal is opened.

2.3.4.2 The CCT shall evaluate the quality of the technical proposals offered by tenderers, then advise tenderers who have submitted responsive technical proposals of the time and place when the financial proposals will be opened. The CCT shall open only the financial proposals of tenderers, who have submitted responsive technical proposals in accordance with the requirements as stated in the Conditions of Tender, and announce the total price and any preference claimed. Return unopened financial proposals to tenderers whose technical proposals were non responsive.

2.3.5 Non-disclosure

The CCT shall not disclose to tenderers, or to any other person not officially concerned with such processes, information relating to the evaluation and comparison of tender offers and recommendations for the award of a contract, until after the award of the contract to the successful tenderer.

2.3.6 Grounds for rejection and disqualification

The CCT shall determine whether there has been any effort by a tenderer to influence the processing of tender offers and instantly disqualify a tenderer (and his tender offer) if it is established that he engaged in corrupt or fraudulent practices.

2.3.7 Test for responsiveness

2.3.7.1 Appoint a Bid Evaluation Committee and determine after opening whether each tender offer properly received:

- a) complies with the requirements of these Conditions of Tender,
- b) has been properly and fully completed and signed, and
- c) is responsive to the other requirements of the tender documents.

2.3.7.2 A responsive tender is one that conforms to all the terms, conditions, and specifications of the tender documents without material deviation or qualification. A material deviation or qualification is one which, in the CCT's opinion, would:

- a) Detrimentially affect the scope, quality, or performance of the goods, services or supply identified in the Specifications,
- b) Significantly change the CCT's or the tenderer's risks and responsibilities under the contract, or
- c) affect the competitive position of other tenderers presenting responsive tenders, if it were to be rectified.

Reject a non-responsive tender offer, and not allow it to be subsequently made responsive by correction or withdrawal of any material deviation or qualification.

The CCT reserves the right to accept a tender offer which does not, in the CCT's opinion, materially and/or substantially deviate from the terms, conditions, and specifications of the tender documents.

2.3.8 Arithmetical errors, omissions and discrepancies

2.3.8.1 Check the responsive tenders for:

- a) The gross misplacement of the decimal point in any unit rate;
- b) Omissions made in completing the Price Schedule; or
- c) Arithmetic errors in:
 - i) line item totals resulting from the product of a unit rate and a quantity in the Price Schedule; or
 - ii) The summation of the prices; or
 - iii) Calculation of individual rates.

2.3.8.2 The CCT must correct the arithmetical errors in the following manner:

- a) Where there is a discrepancy between the amounts in words and amounts in figures, the amount in words shall govern.
- b) If pricing schedules apply and there is an error in the line item total resulting from the product of the unit rate and the quantity, the line item total shall govern and the rate shall be corrected. Where there is an obviously gross misplacement of the decimal point in the unit rate, the line item total as tendered shall govern, and the unit rate shall be corrected.
- c) Where there is an error in the total of the prices either as a result of other corrections required by this checking process or in the tenderer's addition of prices, the total of the prices shall govern and the tenderer will be asked to revise selected item prices (and their rates if Price Schedules apply) to achieve the tendered total of the prices.

Consider the rejection of a tender offer if the tenderer does not correct or accept the correction of the arithmetical error in the manner described above.

2.3.8.3 In the event of tendered rates or lump sums being declared by the CCT to be unacceptable to it

because they are not priced, either excessively low or high, or not in proper balance with other rates or lump sums, the tenderer may be required to produce evidence and advance arguments in support of the tendered rates or lump sums objected to. If, after submission of such evidence and any further evidence requested, the CCT is still not satisfied with the tendered rates or lump sums objected to, it may request the tenderer to amend these rates and lump sums along the lines indicated by it.

The tenderer will then have the option to alter and/or amend the rates and lump sums objected to and such other related amounts as are agreed on by the CCT, but this shall be done without altering the tender offer in accordance with this clause.

Should the tenderer fail to amend his tender in a manner acceptable to and within the time stated by the CCT, the CCT may declare the tender as non-responsive.

2.3.9 Clarification of a tender offer

The CCT may, after the closing date, request additional information or clarification from tenderers, in writing on any matter affecting the evaluation of the tender offer or that could give rise to ambiguity in a contract arising from the tender offer, which written request and related response shall not change or affect their competitive position or the substance of their offer. Such request may only be made in writing by the Director: Supply Chain Management using any means as appropriate.

2.3.10 Evaluation of tender offers

2.3.10.1 General

2.3.10.1.1 The CCT may reduce each responsive tender offer to a comparative price and evaluate them using the tender evaluation methods and associated evaluation criteria and weightings that are specified in the Conditions of Tender.

2.3.10.1.2 For evaluation purposes only, the effects of the relevant contract price adjustment methods will be considered in the determination of comparative prices as follows:

- a) If the selected method is based on bidders supplying rates or percentages for outer years, comparative prices would be determined over the entire contract period based on such rates or percentages.
- b) If the selected method is based on a formula, indices, coefficients, etc. that is the same for all bidders during the contract period, comparative prices would be the prices as tendered for year one.
- c) If the selected method is based on a formula, indices, coefficients, etc. that varies between bidders, comparative prices would be determined over the entire contract period based on published indices relevant during the 12 months prior to the closing date of tenders.
- d) If the selected method includes an imported content requiring rate of exchange variation, comparative prices would be determined based on the exchange rates tendered for the prices as tendered for year one. The rand equivalent of the applicable currency 14 days prior to the closing date of tender will be used (the CCT will check all quoted rates against those supplied by its own bank).
- e) If the selected method is based on suppliers' price lists, comparative prices would be the prices as tendered for year one.
- f) If the selected method is based on suppliers' price lists and / or rate of exchange, comparative prices would be determined as tendered for year one whilst taking into account the tendered percentage subject to rate of exchange (see sub clause (d) for details on the calculation of the rate of exchange).

2.3.10.1.3 Where the scoring of functionality forms part of a bid process, each member of the Bid Evaluation Committee must individually score functionality. The individual scores must then be interrogated and calibrated if required where there are significant discrepancies. The individual scores must then be added together and averaged to determine the final score.

2.3.10.2 Decimal places

Score financial offers, preferences and functionality, as relevant, to two decimal places.

2.3.10.3 Scoring of tenders (price and preference)

2.3.10.3.1 Points for price will be allocated in accordance with the formula set out in this clause based on the price per item / rates as set out in the **Price Schedule (Section 7)**:

- Based on the sum of the prices/rates in relation to the estimated quantities.

2.3.10.3.2 Points for preference will be allocated in accordance with the provisions of **Preference Schedule** and the table in this clause.

2.3.10.3.3 The terms and conditions of **Preference Schedule** as it relates to preference shall apply in all respects to the tender evaluation process and any subsequent contract.

2.3.10.3.4 Applicable formula:

The 90/10 price preference points system will be applied to the evaluation of responsive tenders above a Rand value of R50'000'000 (all applicable taxes included), whereby the order(s) will be placed with the tenderer(s) scoring the highest total number of adjudication points.

Price shall be scored as follows:

$$P_s = 90 \times \left(1 - \frac{P_t - P_{min}}{P_{min}}\right)$$

Where: Ps is the number of points scored for price;
Pt is the price of the tender under consideration;
Pmin is the price of the lowest responsive tender.

Preference points shall be based on the Specific Goal as per below:

Table B2: Awards above R50 mil (VAT Inclusive)

#	Specific goals allocated points	Preference Points (90/10) <i>Above R50 mil</i>	Evidence	Additional Guidance
<i>Persons, or categories of persons, historically disadvantaged- (HDI) by unfair discrimination on the basis of</i>				
1	Gender are women (ownership)* >75% - 100% women ownership: 3 points >50% - 75% women ownership: 2 points >25% - 50% women ownership: 1 point >0% - 25% women ownership: 0.5 point 0% women ownership = 0 points	3	<ul style="list-style-type: none"> Company Registration Certification Central Supplier Database report 	<ul style="list-style-type: none"> Issued by the Companies and Intellectual Property Commission Report name: CSD Registration report
2	Race are black persons (ownership)* >75% - 100% black ownership: 3 points >50% - 75% black ownership: 2 points >25% - 50% black ownership: 1 point >0% - 25% black ownership: 0.5 point 0% black ownership = 0 points	3	<ul style="list-style-type: none"> B-BBEE certificate; Company Registration Certification Central Supplier Database report 	<ul style="list-style-type: none"> South African National Accreditation System approved certificate or commissioned sworn affidavit Issued by the Companies and Intellectual Property Commission Report name: CSD Registration report
3	Disability are disabled persons (ownership)*	1	<ul style="list-style-type: none"> Proof of disability 	<ul style="list-style-type: none"> Medical certificate/ South African Revenue Services disability registration

	WHO disability guideline >2% ownership: 1 points >0% - 2% ownership: 0.5 point 0% ownership = 0 point		<ul style="list-style-type: none"> Company Registration Certification 	<ul style="list-style-type: none"> Issued by the Companies and Intellectual Property Commission
<i>Reconstruction and Development Programme (RDP) as published in Government Gazette</i>				
4	<p>Promotion of Micro and Small Enterprises Micro with a turnover up to R20million and Small with a turnover up to R80 million as per National Small Enterprise Act, 1996 (Act No.102 of 1996)</p> <p>SME partnership, sub-contracting, joint venture or consortiums</p>	3	<ul style="list-style-type: none"> B-BBEE status level of contributor; South African owned enterprises; Financial Statement to determine annual turnover 	<ul style="list-style-type: none"> Specifically in line with the respective sector codes which the company operates, South African National Accreditation System approved certificate or commissioned sworn affidavit Certificate of incorporation or commissioned sworn affidavit Latest financial statements (1 Year)
	Total points	10		

**Ownership: main tendering entity*

2.3.10.5 Risk Analysis

Notwithstanding compliance with regard to any requirements of the tender, the CCT will perform a risk analysis in respect of the following:

- a) reasonableness of the financial offer
- b) reasonableness of unit rates and prices
- c) the tenderer's ability to fulfil its obligations in terms of the tender document, that is, that the tenderer can demonstrate that he/she possesses the necessary professional and technical qualifications, professional and technical competence, financial resources, equipment and other physical facilities, managerial capability, reliability, capacity, experience, reputation, personnel to perform the contract, etc.; the CCT reserves the right to consider a tenderer's existing contracts with the CCT in this regard
- d) any other matter relating to the submitted bid, the tendering entity, matters of compliance, verification of submitted information and documents, etc.

The conclusions drawn from this risk analysis will be used by the CCT in determining the acceptability of the tender offer.

No tenderer will be recommended for an award unless the tenderer has demonstrated to the satisfaction of the CCT that he/she has the resources and skills required.

2.3.11 Negotiations with preferred tenderers

The CCT may negotiate the final terms of a contract with tenderers identified through a competitive tendering process as preferred tenderers provided that such negotiation:

- a) Does not allow any preferred tenderer a second or unfair opportunity;
- b) Is not to the detriment of any other tenderer; and
- c) Does not lead to a higher price than the tender as submitted.

If negotiations fail to result in acceptable contract terms, the City Manager (or his delegated authority) may terminate the negotiations and cancel the tender, or invite the next ranked tenderer for negotiations. The original preferred tenderer should be informed of the reasons for termination of the negotiations. If the decision is to invite the next highest ranked tenderer for negotiations, the failed earlier negotiations may not be reopened by the CCT.

Minutes of any such negotiations shall be kept for record purposes.

The provisions of this clause will be equally applicable to any invitation to negotiate with any other tenderers.

In terms of the CCT's SCM Policy, tenders must be cancelled in the event that negotiations fail to achieve a market related price with any of the three highest scoring tenderers.

2.3.12 Acceptance of tender offer

Notwithstanding any other provisions contained in the tender document, the CCT reserves the right to:

2.3.12.1 Accept a tender offer(s) which does not, in the CCT's opinion, materially and/or substantially deviate from the terms, conditions, and specifications of the tender document.

2.3.12.2 Accept the whole tender or part of a tender or any item or part of any item or items from multiple manufacturers, or to accept more than one tender (in the event of a number of items being offered), and the CCT is not obliged to accept the lowest or any tender.

2.3.12.3 Accept the tender offer(s), if in the opinion of the CCT, it does not present any material risk and only if the tenderer(s):

- a) is not under restrictions, has any principals who are under restrictions, or is not currently a supplier to whom notice has been served for abuse of the supply chain management system, preventing participation in the CCT's procurement,
- b) can, as necessary and in relation to the proposed contract, demonstrate that he or she possesses the professional and technical qualifications, professional and technical competence, financial resources, equipment and other physical facilities, managerial capability, reliability, experience and reputation, expertise and the personnel, to perform the contract,
- c) has the legal capacity to enter into the contract,
- d) is not insolvent, in receivership, under Business Rescue as provided for in chapter 6 of the Companies Act, 2008, bankrupt or being wound up, has his affairs administered by a court or a judicial officer, has suspended his business activities, or is subject to legal proceedings in respect of any of the foregoing, complies with the legal requirements, if any, stated in the tender data, and
- e) is able, in the opinion of the CCT, to perform the contract free of conflicts of interest.

If an award cannot be made in terms of anything contained herein, the CCT reserves the right to consider the next ranked tenderer(s).

2.3.12.4 The CCT reserves the right not to make an award, or revoke an award already made, where the implementation of the contract may result in reputational risk or harm to the CCT as a result of (inter alia):

- a) reports of poor governance or unethical behaviour, or both;
- b) association with known notorious individuals and family of notorious individuals;
- c) poor performance issues, known to the CCT;
- d) negative media reports, including negative social media reports;
- e) adverse assurance (e.g. due diligence) report outcomes; and
- f) circumstances where the relevant vendor has employed, or is directed by, anyone who was previously employed in the service of the state (as defined in clause 1.53 of the SCM Policy), where the person is or was negatively implicated in any SCM irregularity.

2.3.12.5 The CCT reserves the right to nominate an StandbyBidder at the time when an award is made and in the event that a contract is terminated during the execution thereof, the CCT may consider the award of the contract, or non-award, to the Standby Bidder in terms of the procedures included its SCM Policy.

2.3.13 Prepare contract documents

2.3.13.1 If necessary, revise documents that shall form part of the contract and that were issued by the CCT

as part of the tender documents to take account of:

- a) Notices issued during the tender period,
- b) Inclusion of some of the returnable documents, and
- c) Other revisions agreed between the CCT and the successful tenderer.

2.3.13.2 Complete the schedule of deviations attached to the form of offer and acceptance, if any.

2.3.14 Notice to successful and unsuccessful tenderers

2.3.14.1 Before accepting the tender of the successful tenderer the CCT shall notify the successful tenderer in writing of the decision of the CCT's Bid Adjudication Committee to award the tender to the successful tenderer. No rights shall accrue to the successful tenderer in terms of this notice

2.3.14.2 The CCT shall, at the same time as notifying the successful tenderer of the Bid Adjudication Committee's decision to award the tender to the successful tenderer, also give written notice to the other tenderers informing them that they have been unsuccessful.

2.3.15 Provide written reasons for actions taken

Provide upon request written reasons to tenderers for any action that is taken in applying these Conditions of Tender, but withhold information which is not in the public interest to be divulged, which is considered to prejudice the legitimate commercial interests of tenderers or might prejudice fair competition between tenderers.

TENDER DOCUMENT GOODS AND SERVICES		 CITY OF CAPE TOWN ISIXEKO SASEKAPA STAD KAAPSTAD
SUPPLY CHAIN MANAGEMENT		
SCM - 542	Approved by Branch Manager: February 2024	Version: 10 Page 22 of 80

TENDER NO: 241G/2023/24
TENDER DESCRIPTION: SUPPLY AND DELIVERY OF LANDFILL PLANT AND EQUIPMENT
CONTRACT PERIOD: NOT EXCEEDING THIRTY SIX (36) MONTHS FROM THE DATE OF COMMENCEMENT OF CONTRACT

THE CONTRACT

THE CITY OF CAPE TOWN	
A metropolitan municipality, established in terms of the Local Government: Municipal Structures Act, 117 of 1998 read with the Province of the Western Cape: Provincial Gazette 5588 dated 22 September 2000, as amended ("the Purchaser") herein represented by	
AUTHORISED REPRESENTATIVE	

AND

SUPPLIER	
NAME of Company/Close Corporation or Partnership / Joint Venture/ Consortium or Sole Proprietor /Individual (The "Supplier" / "tenderer")	
TRADING AS (if different from above)	
REGISTRATION NUMBER	
PHYSICAL ADDRESS / CHOSEN DOMICILIUM CITANI ET EXECTUANDI OF THE SUPPLIER	
AUTHORISED REPRESENTATIVE	
CAPACITY OF AUTHORISED REPRESENTATIVE	

(HEREINAFTER COLLECTIVELY REFERRED TO AS "THE PARTIES" AND INDIVIDUALLY A "PARTY")

NATURE OF TENDER OFFER (please indicate below)	
Main Offer (see clause 2.2.11.1)	
Alternative Offer (see clause 2.2.11.1)	

C.1 DETAILS OF TENDERER/SUPPLIER

1.1 Type of Entity (Please tick one box)

<input type="checkbox"/> Individual / Sole Proprietor	<input type="checkbox"/> Close Corporation	<input type="checkbox"/> Company	
<input type="checkbox"/> Partnership or Joint Venture or Consortium	<input type="checkbox"/> Trust	<input type="checkbox"/> Other:	

1.2 Required Details (Please provide applicable details in full):

Name of Company / Close Corporation or Partnership / Joint Venture / Consortium or Individual /Sole Proprietor	
Trading as (if different from above)	
Company / Close Corporation registration number (if applicable)	
Postal address	Postal Code _____
Physical address (Chosen Domicilium Citandi Et Executandi)	Postal Code _____
Contact details of the person duly authorised to represent the tenderer	Name: Mr/Ms _____ (Name & Surname) Telephone : (____) _____ Fax : (____) _____ Cellular Telephone: _____ E-mail address: _____
Income tax number	
VAT registration number	
SARS Tax Compliance Status PIN	
CCT Supplier Database Registration Number (See Conditions of Tender)	
National Treasury Central Supplier Database registration number (See Conditions of Tender)	
Is tenderer the accredited representative in South Africa for the Goods / Services / Works offered?	<input type="checkbox"/> Yes <input type="checkbox"/> No If yes, enclose proof
Is tenderer a foreign based supplier for the Goods / Services / Works offered?	<input type="checkbox"/> Yes <input type="checkbox"/> No If yes, answer the Questionnaire to Bidding Foreign Suppliers (below)
Questionnaire to Bidding Foreign Suppliers	a) Is the tenderer a resident of the Republic of South Africa or an entity registered in South Africa? <input type="checkbox"/> Yes <input type="checkbox"/> No
	b) Does the tenderer have a permanent establishment in the Republic of South Africa? <input type="checkbox"/> Yes <input type="checkbox"/> No
	c) Does the tenderer have any source of income in the Republic of South Africa? <input type="checkbox"/> Yes <input type="checkbox"/> No
	d) Is the tenderer liable in the Republic of South Africa for any form of taxation? <input type="checkbox"/> Yes <input type="checkbox"/> No

C.2 FORM OF OFFER AND ACCEPTANCE

TENDER NO. 241G/2023/24 SUPPLY AND DELIVERY OF LANDFILL PLANT AND EQUIPMENT

C.2.1 Offer (To Be Completed by the Tenderer as Part of Tender Submission)

The tenderer, identified in the offer signature table below,

HEREBY AGREES THAT by signing the *Form of Offer and Acceptance*, the tenderer:

1. confirms that it has examined the documents listed in the Index (including Schedules and Annexures) and has accepted all the Conditions of Tender;
2. confirms that it has received and incorporated any and all notices issued to tenderers issued by the CCT;
3. confirms that it has satisfied itself as to the correctness and validity of the tender offer; that the price(s) and rate(s) offered cover all the goods and/or services specified in the tender documents; that the price(s) and rate(s) cover all its obligations and accepts that any mistakes regarding price(s), rate(s) and calculations will be at its own risk;
4. offers to supply all or any of the goods and/or render all or any of the services described in the tender document to the CCT in accordance with the:
 - 4.1 terms and conditions stipulated in this tender document;
 - 4.2 specifications stipulated in this tender document; and
 - 4.3 at the prices as set out in the **Price Schedule**.
5. accepts full responsibility for the proper execution and fulfilment of all obligations and conditions devolving on it in terms of the Contract.

SIGNED AT _____ (PLACE) ON THE _____ (DAY) OF _____ (MONTH AND YEAR)

For and on behalf of the Supplier
(Duly Authorised)
Name and Surname:

Witness 1 Signature
Name and Surname:

Witness 2 Signature
Name and Surname:

INITIALS OF CCT OFFICIALS		
1	2	3

FORM OF OFFER AND ACCEPTANCE (continued)

TENDER NO. 241G/2023/24 SUPPLY AND DELIVERY OF LANDFILL PLANT AND EQUIPMENT

C.2.2 Acceptance (To Be Completed by the CCT)

By signing this part of this *Form of Offer and Acceptance*, the CCT accepts the tenderer's (if awarded the Supplier's) offer. In consideration thereof, the CCT shall pay the Supplier the amount due in accordance with the conditions of contract. Acceptance of the Supplier's offer shall form an agreement between the CCT and the Supplier upon the terms and conditions contained in this document.

The terms of the agreement are contained in the Contract (as defined) including drawings and documents or parts thereof, which may be incorporated by reference.

Deviations from and amendments to the documents listed in the tender data and any addenda thereto as listed in the *Tender Returnable Documents* as well as any changes to the terms of the offer agreed by the tenderer and the CCT during this process of offer and acceptance, are contained in the *Schedule of Deviations* attached to and forming part of this *Form of Offer and Acceptance*. No amendments to or deviations from said documents are valid unless contained in the *Schedule of Deviations*.

The Supplier shall within 2 (two) weeks after receiving a complete, copy of the Contract, including the *Schedule of Deviations* (if any), contact the CCT to arrange the delivery of any securities, bonds, guarantees, proof of insurance and any other documents to be provided in terms the *Special Conditions of Contract*. Failure to fulfil any of these obligations in accordance with those terms shall constitute a repudiation / breach of the agreement.

Notwithstanding anything contained herein, this agreement comes into effect on the Commencement Date, being the date upon which the Supplier confirms receipt from the CCT of 1 (one) complete, signed copy of the Contract, including amendments or deviations contained in the *Schedule of Deviations* (if any).

For and on behalf of the City of Cape Town
(Duly Authorised)
Name and Surname:

Witness 1 Signature
Name and Surname:

Witness 2 Signature
Name and Surname:

FORM OF OFFER AND ACCEPTANCE (continued)

TENDER NO. 241G/2023/24 SUPPLY AND DELIVERY OF LANDFILL PLANT AND EQUIPMENT

C.2.3 Schedule of Deviations (To be Completed by the CCT upon Acceptance)

Notes:

- 1. The extent of deviations from the tender documents issued by the CCT before the tender closing date, is limited to those permitted in terms of the conditions of tender.
- 2. A tenderer's covering letter shall not be included in the final Contract document. Should any matter in such letter, which constitutes a deviation as aforesaid, become the subject of agreements reached during the process of offer and acceptance, the outcome of such agreement shall be recorded here.
- 3. Any other matter arising from the process of offer and acceptance either as a confirmation, clarification or change to the tender documents and which it is agreed by the Parties to become an obligation of the Contract, shall be recorded here.
- 4. Any change or addition to the tender documents arising from the above agreements and recorded here, shall form part of the Contract.

1 Subject

Details

.....

.....

.....

.....

.....

2 Subject

Details

.....

.....

.....

.....

.....

.....

3 Subject

Details

.....

.....

.....

.....

.....

.....

4 Subject

Details

.....

.....

.....

.....

.....

By the duly authorised representatives signing this agreement, the CCT and the tenderer agree to and accept the foregoing schedule of deviations as the only deviations from and amendments to this tender document and addenda thereto as listed in the *Tender Returnable Documents*, as well as any confirmation, clarification or changes to the terms of the offer agreed by the tenderer and the CCT during this process of offer and acceptance.

It is expressly agreed that no other matter whether in writing, oral communication or implied during the period between the issue of the tender documents and the Commencement Date, shall have any meaning or effect between the Parties arising from the agreement.

FORM OF OFFER AND ACCEPTANCE (continued)

**TENDER NO. 241G/2023/24 SUPPLY AND DELIVERY OF LANDFILL
PLANT AND EQUIPMENT**

C.2.4 Confirmation of Receipt (To be Completed by Supplier upon Acceptance)

The Supplier identified in the offer part of the Contract hereby confirms receipt from the CCT of 1 (one) complete, signed copy of the Contract, including the *Schedule of Deviations* (if any) on:

The..... (Day)

Of..... (Month)

20..... (year)

At..... (Place)

For the Supplier: Signature(s)

Name(s)

Capacity

Signature and name of witness:

Signature Name

C.3 OCCUPATIONAL HEALTH AND SAFETY AGREEMENT

AGREEMENT MADE AND ENTERED INTO BETWEEN THE CCT (HEREINAFTER CALLED THE "CCT") AND

..... ,
(Supplier/Mandatory/Company/CC Name)

IN TERMS OF SECTION 37(2) OF THE OCCUPATIONAL HEALTH AND SAFETY ACT, 85 OF 1993 AS AMENDED.

I,, representing

..... , as an employer in its own right in its own right, do hereby undertake to ensure, as far as is reasonably practicable, that all work will be performed, and all equipment, machinery or plant used in such a manner as to comply with the provisions of the Occupational Health and Safety Act (hereafter "OHSA") and the Regulations promulgated thereunder.

I furthermore confirm that I am/we are registered with the Compensation Commissioner and that all registration and assessment monies due to the Compensation Commissioner have been fully paid or that I/We are insured with an approved licensed compensation insurer.

COID ACT Registration Number:

OR Compensation Insurer: Policy No.:

I undertake to appoint, where required, suitable competent persons, in writing, in terms of the requirements of OHSA and the Regulations and to charge him/them with the duty of ensuring that the provisions of OHSA and Regulations as well as the Council's Special Conditions of Contract, Way Leave, Lock-Out and Work Permit Procedures are adhered to as far as reasonably practicable.

I further undertake to ensure that any subcontractors employed by me will enter into an occupational health and safety agreement separately, and that such subcontractors comply with the conditions set.

I hereby declare that I have read and understand the Occupational Health and Safety Specifications contained in this tender and undertake to comply therewith at all times.

I hereby also undertake to comply with the Occupational Health and Safety Specification and Plan submitted and approved in terms thereof.

Signed at on the day of 20....

Witness

Mandatory

Signed at..... on the..... day of..... 20

Witness

for and on behalf of
CCT

C.4 PRICE SCHEDULE

Bid specifications may not make any reference to any particular trade mark, name, patent, design, type, specific origin or producer, unless there is no other sufficiently precise or intelligible way of describing the characteristics of the work, in which case such reference must be accompanied by the words "or equivalent".

TENDERERS MUST NOTE THAT WHEREVER THIS DOCUMENT REFERS TO ANY PARTICULAR TRADE MARK, NAME, PATENT, DESIGN, TYPE, SPECIFIC ORIGIN OR PRODUCER, SUCH REFERENCE SHALL BE DEEMED TO BE ACCOMPANIED BY THE WORDS 'OR EQUIVALENT'

Pricing Instructions:

- 5.1 State the rates and prices in Rand unless instructed otherwise in the Conditions of Tender.
- 5.2 Include in the rates, prices, and the tendered total of the prices (if any) all duties, taxes (except Value Added Tax (VAT), and other levies payable by the successful tenderer, such duties, taxes and levies being those applicable 14 days before the closing time stated in the General Tender Information.
- 5.3 All prices tendered must include all expenses, disbursements and costs (e.g. transport, accommodation etc.) that may be required for the execution of the tenderer's obligations in terms of the Contract, and shall cover the cost of all general risks, liabilities and obligations set forth or implied in the Contract as well as overhead charges and profit (in the event that the tender is successful). All prices tendered will be final and binding.
- 5.4 All prices shall be tendered in accordance with the units specified in this schedule.
- 5.5 Where a value is given in the Quantity column, a Rate and Price (the product of the Quantity and Rate) is required to be inserted in the relevant columns.
- 5.6 The successful tenderer is required to perform all tasks listed against each item. The tenderer must therefore tender prices/rates on all items as per the section in the Price Schedule. **An item against which no rate is/are entered, or if anything other than a rate or a nil rate (for example, a zero, a dash or the word "included" or abbreviations thereof) is entered against an item, it will also be regarded as a nil rate having been entered against that item, i.e. that there is no charge for that item. The Tenderer may be requested to clarify nil rates, or items regarded as having nil rates; and the CCT may also perform a risk analysis with regard to the reasonableness of such rates.**
- 5.7 Provide fixed rates and prices for the duration of the contract that are not subject to adjustment except as otherwise provided for in clause 17 of the Conditions of Contract and as amplified in the Special Conditions of Contract.
- 5.8 Tenderers must include the licensing, registration, number plate costs and all other associate costs in the tender price (main item) as a once off cost as prescribed by the Road Traffic Act.
- 5.9 The tender will be evaluated on main items only and not on the optional extras. However, tenderers are required provide prices for the main item and all its optional extras offered under the pricing schedule table below. **Failure to do so will render the tenderer non-responsive**

Item No	Description	Make and Model	Delivery Period (Weeks from date of purchase order)	Net Unit Price (Excl. VAT)
1	18 KL Water Tanker		Wks	R

Item No	Description	Product Name	Net Unit Price (Excl. VAT)
1.1	Supply and installation of a proprietary brand auto lube system for automatic greasing of bearings		R
1.2	The supply and fitment of a 20m proprietary brand hose reel		R
1.3	The tender shall quote for supplying proprietary brand OTR tyres filled with 20 Litre proprietary brand foam as an optional extra.		R
1.4	Supply and installation of a proprietary brand dual medium fire suppression system.		R
1.5	Corrosion Protection		R

Item No	Description	Make and Model	Delivery Period (Weeks from date of purchase order)	Net Unit Price (Excl. VAT)
2	ADT 25 Ton Container Carrying		Wks	R

Item No	Description	Product Name	Net unit price (excl. Vat)
2.1	Supply and installation of a proprietary brand auto lube system for automatic greasing of bearings.		R
2.2	Supply and installation of a proprietary brand dual medium fire suppression system.		R
2.3	Corrosion Protection		R

INITIALS OF CITY OFFICIALS		
1	2	3

Item No	Description	Make and Model	Delivery Period (Weeks from date of purchase order)	Net Unit Price (Excl. VAT)
3	ADT 25 Ton with Hook Lift		Wks	R

Item No	Description	Product Name	Net unit price (excl. Vat)
3.1	Supply and installation of a proprietary brand auto lube system for automatic greasing of bearings.		R
3.2	Supply and installation of a proprietary brand dual medium fire suppression system.		R
3.3	Corrosion Protection		R

Item No	Description	Make and Model	Delivery Period (Weeks from date of purchase order)	Net Unit Price (Excl. VAT)
4	18Ton Wheeled Loader		Wks	R

Item No	Description	Product Name	Net unit price (excl. Vat)
4.1	Supply and installation of a proprietary brand auto lube system for automatic greasing of bearings.		R
4.2	Corrosion Protection		R

INITIALS OF CITY OFFICIALS		
1	2	3

Item No	Description	Make and Model	Delivery Period (Weeks from date of purchase order)	Net Unit Price (Excl. VAT)
5	Landfill Compactor		Wks	R

Item No	Description	Product Name	Net unit price (excl. Vat)
5.1	Supply and installation of a proprietary brand auto lube system for automatic greasing of bearings.		R
5.2	Supply and installation of a proprietary brand dual medium fire suppression system.		R
5.3	Corrosion Protection		R

Item No	Description	Make and Model	Delivery Period (Weeks from date of purchase order)	Net Unit Price (Excl. VAT)
6	Track Type Dozer		Wks	R

Item No	Description	Product Name	Net unit price (excl. Vat)
6.1	Supply and installation of a proprietary brand auto lube system for automatic greasing of bearings.		R
6.2	Supply and installation of a proprietary brand dual medium fire suppression system.		R
6.3	Corrosion Protection		R

INITIALS OF CCT OFFICIALS		
1	2	3

C.5 SPECIFICATION(S)

TECHNICAL SPECIFICATION

ITEM 1 – 23 000L WATER TANKER

TRACTOR OEM		WATER TANK OEM	
TRACTOR MODEL		WATER TANK MODEL	
COUNTRY OF ORIGIN		COUNTRY OF ORIGIN	

NO	(1)	DESCRIPTION (2)	COMPLY? (3) YES / NO	BROCHURE (4) REFERENCE INFO
		ITEM 1 – 23 000 L WATER TANKER		
1		SPECIFICATION SUMMARY		
1.1		A heavy duty three - axle diesel powered, centrally articulated tractor in 6X6 configuration with matching water tanker with a minimum capacity of 23 000 liters is required for dust suppression and to transport leachate at the City of Cape Town’s landfill sites.
1.2		The tractor chassis offered as well as the matching water tank must be a proven proprietary brand, of the latest design and material construction for operation off the highway on uneven, rough terrain.
1.3		Clearly <u>highlighted</u> original OEM brochures describing in detail the articulated tractor and water tanker combinations adherence to this technical specification, must be submitted with tender submission or as and when required by the City of Cape Town’s technical evaluation team.
1.4		The entire tender document must be scanned in searchable PDF format and submitted on a flash drive along with the tender document. Scanning in jpg format is not acceptable.
2		TENDERERS GUIDE		
2.1		The tenderer is to carefully scrutinize each clause and fill in the document as follows:-
2.2		Full compliance to the requirement of the technical specification clause must be indicated by the word “Yes” or “No” in column 3.
2.3		If a required item is standard fitment, then the word “Standard” may be written in column 4 in addition to the “Yes” in column 3.
2.4		In the case of “No” being entered the tenderer may offer an explanation in the column 4.

NO (1)	DESCRIPTION (2) ITEM 1 – 23 000 L WATER TANKER	COMPLY? (3) YES / NO	BROCHURE (4) REFERENCE INFO
2.5	Where specific data is required, this may be referenced in column 4 by means of a OEM brochure page number and then the respective clauses highlighted/underlined in such named brochures for ease of evaluation.
3	MAINTENANCE AND SERVICING FACILITIES		
3.1	TRACTOR		
3.1.1	The tenderer must either have or have access to, accredited and fully equipped facilities within the boundaries of City of Cape Town area which are OEM approved for the maintenance, repairs including structural, hydraulic, diagnostics and major component overhauls of the articulated truck chassis and water tank combination offered.
3.1.2	TRACTOR MAINTENANCE Facility Address GPS Co-ordinates S°'" E°'"
3.1.3	WATER TANK MAINTENANCE Facility Address GPS Co-ordinates S°'" E°'"
3.1.4	a) Tenderers must provide either a letter from the OEM or a copy of the Service Level Agreement (SLA) with their service provider indicating that: - b) the facilities offered are OEM approved for the maintenance, repair, diagnostic testing and major overhauls of the articulated truck chassis and water tank combination offered. while under warranty. c) Tenderers who do not to have access to established OEM accredited facilities must refer to 36.1 of the Special Conditions of Contract for guidance if they wish to participate in this tender. d) In this context the tenderer is pay attention to the requirements of the Condition of Tender clauses 2.2.1.1.8. to 2.2.1.1.11
4	DEFINITIONS		
4.1	The complete water tanker i.e. tractor and water tank will be referred to as the “vehicle” in the technical specification.
5	APPLICABLE STANDARDS (AS AMMENDED)		
5.1	SANS 1517:2005: - Lubricating oil diesel engines
5.2	SANS 10281:2003 - Sound levels
5.3	SANS 20049:2009 - Particulate pollutants engines

NO (1)	DESCRIPTION (2) ITEM 1 – 23 000 L WATER TANKER	COMPLY? (3) YES / NO	BROCHURE (4) REFERENCE INFO
5.4	SANS 10168:2002 - Restraining devices (safety belts) in vehicles
5.5	SANS 12944-4:2023 - Paints and varnishes – Corrosion protection of steel structures by protective paint systems – Part 4: Types of surface and surface preparation
5.6	SANS 12944-5:2023 - Paints and varnishes – Corrosion protection of steel structures by protective paint systems – Part 5: Protective paint systems.
5.7	SANS 12944-7:2023 - Paints and varnishes – Corrosion protection of steel structures by protective paint systems – Part 7: Execution and supervision of paint work. D
5.8	ISO 9533: - Audible warning systems
5.9	IEC 60529 IP66 - Ingress protection rating – water and dust
5.10	ISO 3471:2008 - Earth-moving machinery - Roll-over protective structures
5.11	ISO 3449:2005:- Earth-moving machinery - Falling-object protective structures
5.12	ISO 3471, SAE J1040 / ISO 3449, SAE J231: - ROPS / FOPS
5.13	Addendum 13B : General Technical Specifications
6	CHASSIS		
6.1	The chassis is to be constructed from high-strength, welded-alloy steel and all articulation joints reinforced according to OEM standards.
6.2	The machine shall have an articulated chassis with full hydraulic power steering.
6.3	a) The central oscillation joint shall be a sealed and maintenance free type with permanently greased tapered roller bearings to allow independent movement of the tractor and water tanker without frame twist, whilst providing for good ground contact in rough landfill site conditions. b) Other proprietary oscillation joint designs with the same functionality will however also be accepted.
6.4	The vehicle must be fitted with under-side protection guards (6mm minimum thickness mild steel plate) under the engine and transmission compartments, as well as driveline protection

NO (1)	DESCRIPTION (2) ITEM 1 – 23 000 L WATER TANKER	COMPLY? (3) YES / NO	BROCHURE (4) REFERENCE INFO
6.5	The chassis is to incorporate a centralised easily accessible lubrication bank for ease of greasing remote and hard to reach points.
6.6	The diesel tank must be positioned for maximum ground clearance
6.7	All fuel tank caps and battery boxes must be lockable
6.8	a) The water tank shall be mounted onto the chassis according to the OEM body builders' instructions. b) Excerpts from the body builders manual will be required to validate such fitment.
6.9	See Addendum 1.1 for a basic layout of the vehicle
7	ENGINE		
7.1	The tractor must be equipped with a turbocharged common rail diesel engine delivering a maximum net output of not less than 200 kW and maximum net torque of not less than 1000 Nm measured to SANS 10013-1: 2006 standards.		
7.2	Make and model Capacity Maximum Output (Kw @ rpm) @ Sea level Maximum Torque (Nm @ rpm) @ Sea levelcc ³kWrpmNmrpm
7.3	The vehicle emissions under start up and operating conditions shall comply with the International Euro 3 standard as a minimum. Euro Standard
7.4	Engine performance curves must be shown in technical brochures.
7.5	The engine is required to operate on proprietary brand lubricating oil to the current applicable standards and in use in the heavy vehicle industry in South Africa.
7.6	The engine oil dipstick, fill point, oil and fuel and any particulate filters, and coolant reservoir are to be readily accessible for ease of maintenance.
7.7	The air cleaner fitted must be of the two-stage dry type, incorporating automatic intermittent self-cleaning action and preferably be of South African manufacture.
7.8	The engine and gearbox oil drains must be in easily accessible positions to facilitate emptying without the risk of polluting the environment.

NO (1)	DESCRIPTION (2) ITEM 1 – 23 000 L WATER TANKER	COMPLY? (3) YES / NO	BROCHURE (4) REFERENCE INFO
7.9	ENGINE PROTECTION UNIT (E.P.U.) The tractor shall incorporate a fail safe mechanical engine monitoring system which monitors: - <ul style="list-style-type: none"> - oil pressure; - water temperature; - water level; - engine speed
7.9.1	In the event of a fault condition the EPU shall immediately cut out the engine or decrease engine revs to idle and keep the engine in this state until the fault condition is attended to.
7.9.2	The service plan is to include the necessary periodic inspection and servicing of all sensors according to OEM requirements.
7.10	TURBO PROTECTION SYSTEM A proprietary protection system shall be fitted to prevent damage to the turbo charger in the event the engine is switched off prematurely, “Turboprotect” or equivalent.
8	RADIATOR		
8.1	The radiator shall be equipped with cooling fins spaced at an optimum OEM pitch, able to cool at an ambient temperature of up to 40 deg C.
8.2	The radiator is to be protected by a proprietary brand pre filter screen fitted in a radiator guard panel to protect the fins from being clogged by fine particles / dust such as is found at a landfill site.
8.3	Airflow through the pre-filter must be at the correct OEM prescribed level for proper radiator cooling.
8.4	The radiator guard panel is to be easily removed for purposes of cleaning.
8.5	A reversing fan (or reversible fan) is to incorporated for periodic purging of debris.
8.6	Coolant drains must be placed in an easy to reach position to facilitate emptying without the risk of polluting the environment.
9	TRANSMISSION		

NO (1)	DESCRIPTION (2) ITEM 1 – 23 000 L WATER TANKER	COMPLY? (3) YES / NO	BROCHURE (4) REFERENCE INFO
9.1	<p>The vehicle may be powered by: -</p> <p>a) A complete hydrostatic drive transmission or</p> <p>b) An automatic power-shift transmission and matched torque converter or</p> <p>c) Fully automatic transmission with matched torque converter</p> <p>d) Transmission control modules / shift inhibitor to prevent driveline shock loading must be incorporated where necessary.</p>	<p>.....</p> <p>.....</p> <p>.....</p> <p>.....</p>	<p>.....</p> <p>.....</p> <p>.....</p> <p>.....</p>
9.2	In all cases, an oil sample must be taken and sent to a local laboratory (WearCheck or equivalent) for a baseline gearbox oil cleanliness report. Such report shall accompany the machine on delivery.
9.3	Engine and transmission diagnostics must be possible via connection to a laptop from the vehicles diagnostic port.
10	BRAKES		
10.1	Full details of service brakes, parking brakes, auxiliary brakes and any independent emergency parking brake must be submitted in brochures.
11	STEERING		
11.1	The steering system is to comprise double acting cylinders, with a ground driven emergency steering pump in the event of engine cut out or main hydraulic circuit failure.
11.2	Steering angle in each direction shall be at least 45 degrees
12	WHEELS AND TYRES		
	<p>a) The vehicle must be fitted with suitably sized OTR steel radial tyres, preferably of South African manufacture no smaller than 23.5 R 25 and L4 rated.</p> <p>a) The size and ratings must be freely available within the geographical boundaries of the City of Cape Town.</p>	<p>.....</p> <p>.....</p>	<p>.....</p> <p>.....</p>
13	ELECTRICAL SYSTEM		
13.1	The electrical system shall be 24 volt incorporating deep cycle, AGM (absorption glass mat) type batteries.
13.2	The alternator must not be rated less than 50 Amp
13.3	The battery compartment must be lockable and tamper proof.

NO (1)	DESCRIPTION (2) ITEM 1 – 23 000 L WATER TANKER	COMPLY? (3) YES / NO	BROCHURE (4) REFERENCE INFO
13.4	All electrical wiring connectors must be automotive double-seal type, with wiring in split convoluted loom
13.5	An audible reverse warning beeper with an audio output of not less than 90 dB measured at 1 meter be fitted if not supplied as standard fitment.
13.6	An anti-theft system must be fitted to prevent unauthorized engine starting.
13.7	A master disconnect switch must be available at ground switch.
13.8	LIGHTING		
13.8.1	Please refer to Addendum 13 B clause 13.8 for clarity on LED light fitment. This will apply to any LED lighting supplied as standard on the vehicle.
13.8.2	An audible reverse warning beeper with OEM approved LED type reverse light, must be supplied as standard fitment.
13.8.3	The vehicle shall be fitted with a Class 1, Gen 111 (or better) LED type amber hazard beacon on the truck cab.
13.8.4	Class 1, Gen 111 (or better) LED type work lights, rated at least 20W output, shall be mounted on the rear and sides of the tank facing outwards and the front of the cab facing forwards.
14	CAB		
14.1	The cab shall be weatherproof, lockable, with tinted safety glass windows which shall allow an unobstructed view of all operations.
14.2	The cab shall be ROPS (roll over protection) and FOPS (falling object) protected and shall be installed on anti-vibration mounts onto the chassis.
14.3	The vehicle suspension type must be selected to minimise vibration transmitted to the cab.
14.4	Noise level measured at the driver's ear shall be less than 80 Db(A)
14.5	The operator's seat shall be a heated, air suspension type and be adjustable for rake, position and the mass of the operator, and shall be cushioned and upholstered in durable material. Padded armrests shall be fitted
14.6	Driver seatbelt and passenger seatbelt (if applicable) shall be fitted
14.7	Adequate front and rear wipers and washers shall be fitted

NO (1)	DESCRIPTION (2) ITEM 1 – 23 000 L WATER TANKER	COMPLY? (3) YES / NO	BROCHURE (4) REFERENCE INFO
14.8	A proprietary brand AM / FM radio with auxiliary and USB inputs as well as blue tooth functionality, shall be fitted in the event that the vehicle is not supplied with one as a standard fitment.
14.9	The cab shall be fitted with a proprietary brand HVAC climate control system if not a standard fitment.
14.10	The cab shall be fitted with a high efficiency particulate air (HEPA) filter system designed to trap microscopic pollutants including pollen, mould and common allergens
14.11	If an hour meter is not offered as standard, then: - a) A non-tamper proof digital hour meter (Hella or equivalent) logging engine hours must be mounted in a convenient and easily visible position on dashboard b) The instrument must have a metering capacity of 9999 hrs with a digital readout of 1/10 th of an hour. c) The meter must be connected to the alternator circuit.
14.12	A proprietary brand reversing camera system with colour LCD monitor shall be installed in the cab "LiftCam HD" or equivalent is to be installed.
14.13	2x 4.5kg Dry Powder Fire Extinguishers to be securely mounted inside cab.F		
15	HYDRAULIC SYSTEM		
15.1	The hydraulic system is to accommodate a full load sensing system feeding the internal hydraulic functions.
15.2	A ground-driven, load sensing emergency steering pump is to be integrated into the main hydraulic system.
15.3	OIL CLEANLINESS		
15.3.1	The vehicle reservoirs must be filled oil to a classification ISO-L-HV in accordance ISO 6743 - 4, viscosity grade 46 hydraulic oil at a VI of at least 140. Shell Tellus S2 V46 or equivalent.
15.3.2	The cleanliness standards as set out in ISO 4406 and must be equal to or better than 18/16/14
15.3.3	Under no circumstances must "new" oil be decanted directly from drums into reservoirs without first going through an oil polishing unit to obtain the required cleanliness level.
15.3.4	The hydraulic oil tank shall incorporate easily accessible and replaceable spin on filters.

NO (1)	DESCRIPTION (2) ITEM 1 – 23 000 L WATER TANKER	COMPLY? (3) YES / NO	BROCHURE (4) REFERENCE INFO
15.3.5	Hydraulic pressure check points are to be grouped together in an easily accessible position with standard hydraulic connection points where possible.
16	LUBRICATION		
16.1	Greasing lubrication ports must be located on the outside of the machine where practical without the need for crawling under the machine or into awkward unsafe positions.
17	WATER TANK		
17.1	The water tank shall be a proprietary brand i.e. Mega, ETT or similar design, professionally customised and built for the particular articulated tractor chassis offered.
17.2	The tank design shall be of sturdy construction with a low centre of gravity and section thicknesses adequate to safely hold at least 23 000 liters of water.
17.3	At least two lateral anti-surge baffle plates, constructed to industry standards shall be incorporated into the tank. The compartments so formed shall each have an access port.
17.4	The tank including the internals shall be abrasive blasted, primed and coated with an anti-corrosive, marine quality paint, epoxy mastic or equivalent.
17.5	Replaceable proprietary brand, magnesium anodes must be placed in each tank compartment to prevent tank corrosion. The service plan is to indicate when such anodes need replacement.
17.6	Top filler ports, with hinged covers, safety grates and anti-skid walkways.
17.7	Roof access ladder with handrails and tread grip rungs.
17.8	A large drain valve i.e. approx. 100 mm is to be fitted to the bottom of the tank to allow rapid draining of the tank when required.
17.9	Two electronic water gauges shall be fitted, one on the side of the tank to be used while filling, and the other in the drivers cab.
18	SPRAYER SYSTEM		
18.1	The spray system shall incorporate a hydraulically powered centrifugal corrosion resistant water pump capable of at least 1000 liters per minute.
18.2	The water nozzles shall be operated from an electronic control pad in the drivers cab such as supplied by ETT or an equivalent proprietary brand.

NO (1)	DESCRIPTION (2) ITEM 1 – 23 000 L WATER TANKER	COMPLY? (3) YES / NO	BROCHURE (4) REFERENCE INFO
18.3	a) The water pump shall be powered by the vehicle's hydraulic system and shall be manually switchable from tank loading to tank discharge. b) Suitable standard anti corrosion water connections shall be fitted to facilitate the tank loading at the landfill site.
18.4	An anti-siphon fill pipe is to be used to prevent water siphoning back into the main supply.
18.5	The water pump shall be automatically protected from dry running by a suitable proprietary brand controller.
18.6	The spray system shall incorporate :-		
18.6.1	a) A rear spray bar with at least 3 adjustable spray nozzles capable of producing a consistent flat fan spray reaching up to 10 meters to rear and either side of the tank. b) A water deposition rate controller, ETT or equivalent must be fitted to take into account the pump speed and ground speed to ensure a consistent spray coverage avoiding creating pools on the ground or droplets too small that are susceptible to wind.
18.6.2	The spray bar to incorporate a dribble bar / dump bar function allowing penetrating jets into the ground or allowing water to flow out under gravity.
18.6.3	Side nozzles located on either side on the front top of the tank giving a reach not less than 10m
18.6.4	A front spray bar with two (2) nozzles on the front of the tractor with a spray reach of not less than 6 meters is to be fitted to allow a high pressure fan of water to sweep the area in front of the cab.
18.6.5	A manual water cannon located at the tank rear with a reach of up to 40 meters
18.6.6	All spray bars, spray heads, spray head valves, any internal piping and any related external control box enclosure shall be of industrial grade stainless steel for corrosion protection.
19	SPARES HOLDING		

NO (1)	DESCRIPTION (2) ITEM 1 – 23 000 L WATER TANKER	COMPLY? (3) YES / NO	BROCHURE (4) REFERENCE INFO
	<p>a) The tenderer shall guarantee here the availability of a full range of spare parts (running and critical), ex stock for the vehicle within the geographical boundaries of the City of Cape Town.</p> <p>b) Any limitation to the availability shall be explained in a covering letter attached to the tender documents.</p>	<p>.....</p> <p>.....</p>	<p>.....</p> <p>.....</p>
19.1	TRACTOR		
19.1.1	<p>Tenderers shall state the location of spare parts.</p> <p style="text-align: right;">Running spares (Same day)</p> <p style="text-align: right;">Mechanical / driveline spares</p> <p style="text-align: right;">Body components (interior / exterior)</p>	<p>.....</p> <p>.....</p> <p>.....</p>	LOCATION
19.2	WATER TANK INCLUDING PUMPS / PERIPHERALS		
19.2.1	<p>Tenderers shall state the availability of spare parts and the location of the relevant parts. Any limitation to these requirements shall be explained in a covering letter.</p> <p style="text-align: right;">Running spares (Same day)</p> <p style="text-align: right;">Mechanical / Pump / Accessories spares</p>	<p>.....</p> <p>.....</p>	LOCATION
20	WARRANTY		
20.1	VEHICLE		
20.1.1	The complete vehicle must be fully guaranteed for at least 5 years.
21	SERVICE PLAN		
21.1	SERVICE PLAN		
21.1.1	A service plan covering the complete vehicle and fitted accessories for the full warranty period of 5 year or 4000 hr must be offered as an optional extra.
21.1.2	<p>a) Full details of such service plans must be supplied with the tender document or as and when required by the City of Cape Town as an optional extra.</p> <p>b) See Addendum 1.2 for typical service schedules for the vehicle.</p>	<p>.....</p> <p>.....</p>	<p>.....</p> <p>.....</p>
22	OPTIONAL EXTRAS		
22.1	AUTO LUBE SYSTEM		
22.1.1	The tenderer is to offer an auto lubrication system for greasing such remote points as an optional extra.

NO (1)	DESCRIPTION (2) ITEM 1 – 23 000 L WATER TANKER	COMPLY? (3) YES / NO	BROCHURE (4) REFERENCE INFO
22.2	HOSE REEL		
22.2.1	a) The supply and fitment of a 20m proprietary brand hose reel with industry standard flexible piping and suitable nozzle (fog and power stream) with spring rewind is to be offered. b) The water supply for the hose reel will be drawn from the main water pump circuit. c) The location of the hose reel on the tank will be discussed during the build period.
22.3	FOAM FILLED TYRES		
22.3.1	a) The tender shall quote for supplying OTR tyres filled with proprietary brand foam as an optional extra. b) The tenderer shall take note of the additional mass of the foam in the tyres and shall consult with the OEM particularly as regards the ability of the cab to withstand such additional mass when overturned. c) A price reflected in the price schedule will indicate to the City of Cape Town that the OEM has approved such fitment.
22.4	FIRE SUPPRESSION SYSTEM		
22.4.1	The tenderer is to offer a proprietary brand dual agent - DCP and aqueous film forming foam liquid fire suppressant system (Ansulite or similar) as an optional extra. The specified fire suppression system shall incorporate:-
22.4.1.	a) Sufficient and appropriately placed fire-detecting sensing manifold pipes.
	b) A control panel in the cab to detect a fire and alert the operator
	c) Actuators to discharge suppressant automatically and manually
	d) Tanks filled with fire suppressant DCP and aqueous film forming foam (Ansulite or similar)
	e) Distribution network of tubes, hoses, and nozzles
22.5	It is essential that fitment of the fire suppression system be done by a registered qualified artisan / technician in terms of South African legislation set out in this regard.
22.6	The fire suppression system shall carry a 3 year warranty from the date of handover.

NO (1)	DESCRIPTION (2) ITEM 1 – 23 000 L WATER TANKER	COMPLY? (3) YES / NO	BROCHURE (4) REFERENCE INFO
22.7	The City of Cape Town reserves the right to view the tenderers compliance in this regard as and when it deems it fit to do so.
22.8	CORROSION PROTECTION		
22.9	The tenderer has to ensure that the corrosion protective coating is of a type suitable for a South African coastal environment. i.e. Carbo-mastic spec or equivalent		
22.10	Paint coatings chosen shall have the same UV, abrasion and corrosion resistance as the following paint program or better :-		
22.10.1	Abrasive Blast Cleaning. A Class 2½ "Near White Metal" blast cleanliness, metal preparation.		
22.10.2	A proprietary brand two-pack epoxy zinc rich primer for cathodic resistance in harsh corrosive environments		
22.10.3	A proprietary brand two-component high gloss acrylic polyurethane top coat		
22.10.4	The paint offered shall have at least a 5 year corrosion protection following marine quality international standard i.e. Carbo-mastic spec or equivalent.		
22.10.5	The above paints are to be applied in accordance with the manufacturer's recommendations. The Contractor shall arrange for a suitable inspection authority to attend to each stage, approve and submit a report on the application		
23	MANUALS AND TRAINING		
23.3	Properly bound, original approved OEM operators, service and parts manuals in the English language must be provided on delivery.
23.4	<p>a) Training for operators in the proper operation of the vehicle must be provided and included in the tendered price.</p> <p>b) Training for 4 candidates must be provided within two weeks of delivery of the vehicle or as and when required by the City of Cape Town</p>
24	DELIVERY		
24.3	The vehicle shall be registered in the name of the City of Cape Town.
24.4	The cost of licensing, registration, number plates, etc. must be included in the price of the vehicle

NO (1)	DESCRIPTION (2) ITEM 1 – 23 000 L WATER TANKER	COMPLY? (3) YES / NO	BROCHURE (4) REFERENCE INFO
24.5	The vehicle shall have permanent manufacturers plates whereupon relevant data is stamped i.e. the manufacturers name, model no, serial number, and year of manufacture. The plates are to be fixed as per OEM instructions.
24.6	The delivery cost must form part of the main item in the pricing schedule. The transportation of the vehicle must adhere to legal and safety regulations applicable.
24.7	Essential operator tools including wheel spanner and heavy duty hand held grease gun etc. to allow the operator to perform running maintenance is required.
24.8	State whether any free services are included in the tendered price and where such services will be carried out.
24.9	Pre- delivery service cost must be included in the tender price
24.10	Any unacceptable delays in delivery ensuing will attract prescribed penalties.

ADDENDUM 1.1

BASIC SKETCH OF THE VEHICLE REQUIRED

(Not to be construed as a representation of the actual vehicle required)

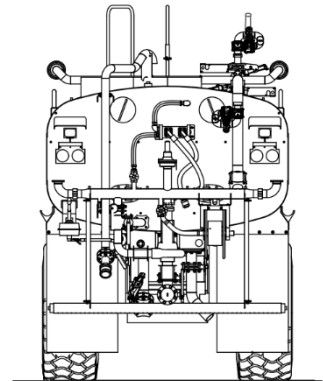
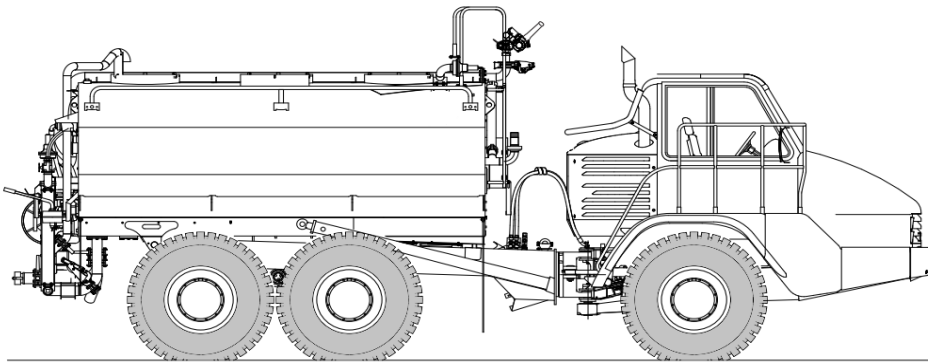

ADDENDUM 1.2

TYPICAL MAINTENANCE AND SERVICING SCHEDULES

The maintenance and service schedules **shall** include all the recommended OEM items for the particular item of plant under consideration. The tables below are not to be construed as complete lists but is merely an indication of the type of service required. The OEM maintenance and service book items shall at all times take preference and must be adhered to.

ADDENDUM 1.2 TABLE 1 - DRIVE LINE

DRIVELINE ITEM 1 - 18000L WATER TANKER	Daily	100 hrs	250 hrs	500 hrs	1000 hrs	2000 hrs	3000 hrs	As Required
ENGINE								
Adjust the valve clearance		X		X				
Change the primary fuel filter		X			X			
Change the secondary fuel filter					X			
Change the oil and oil filters		X	X					
Change the crankcase breather							X	
Change the air cleaner secondary filter						X		
Change the coolant						X		
Check the oil level	X							
Check the coolant level	X							
Check the coolant specification								X
Check drive belts tension			X					
Check engine compartment components								X
Check air cleaner primary filter								X
Clean pre cleaner assembly								X
Drain the primary fuel filter								X
Flush and renew the coolant						X		
Service injectors							X	
GEARBOX								
Change filters					X			
Change oil					X			
Check oil level	X							
HYDRAULICS								
Change oil						X		
Change filters		X					X	
Check breather filter					X			
Check oil level	X							
CHASSIS AND AXLES								
Change oil in differentials and final drives		X				X		
Check the oil level in differentials and final drives			X					
Check service brake pads				X				

DRIVELINE ITEM 1 - 18000L WATER TANKER	Daily	100 hrs	250 hrs	500 hrs	1000 hrs	2000 hrs	3000 hrs	As Required
Check park brake pads				X				
Check wheel nuts								
CAB, PNEUMATICS AND ELECTRICAL		X						
Change the air drier filter					X			
Check operator controls and instruments	X							
Check the working lights, reverse buzzer and	X							
Check electrical connections			X					
LUBRICATION								
Grease hinges					X			
Grease prop shafts						X		
Grease the through drive bearing					X			
Grease the PTO prop shaft					X			
Grease lubrication points	X							

ADDENDUM 1.2 TABLE 2 - WATER TANK

WATER TANK ITEM 1 - 18000L WATER TANKER	WEEKLY 150 hrs	BI WEEKLY 250 hrs	MONTHLY 500 hrs	QUARTERLY 1000 hrs	BI ANNUAL 2500 hrs	ANNUAL 5000 hrs
SPRAY HEADS						
1. Check spray head for damage and clean deflector ring and spray head opening.	X					
2. Check hydraulic and pneumatic lines for security, damage and leaks.	X					
3. Check spray head drop-in assembly for leaks with spray head switch OFF and water pump ON. Replace drop-in assembly as required.			X			
4. Check spray head base plate and upper housing mount bolts for security.			X			
5. Check spray head adjustable deflector ring for damage and correct adjustment. Apply dry-film lubricant to the deflector inner ring.			X			
6. Check spray head base plate for evidence of leaks. Replace base plate O-ring as required.						X
CONTROL SYSTEM						
1. Check all electrical cables for security and damage. Disconnect, clean and coat Deutsch connector junctions with Dielectric grease as required.			X			
2. Check all hydraulic and pneumatic solenoids and hosing for security and leaks.				X		
3. (Hydraulic solenoid box ONLY) Check filter bypass condition. Replace filter if in bypass.				X		

WATER TANK ITEM 1 - 18000L WATER TANKER		WEEKLY 150 hrs	BI WEEKLY 250 hrs	MONTHLY 500 hrs	QUARTERLY 1000 hrs	BI ANNUAL 2500 hrs	ANNUAL 5000 hrs
4.	Check monitor/nozzle assembly for security leaks and condition. Repair as required.				X		
5.	Check supply hoses and shutoff valve for security condition and evidence of suction leaks.				X		
6.	Check all in-cab control functions for proper operation. Repair and replace control components as required.				X		
7.	Check hose reel for security mounting and leaks.			X			
8.	Unreel the entire length of hose, pressurize hose and check hose and nozzle for security, wear and leaks.						X
WATER PUMP SYSTEM ITEM 1 – 18000L WATER TANKER		WEEKLY 150 hrs	BI WEEKLY 250 hrs	MONTHLY 500 hrs	QUARTERLY 1000 hrs	BI ANNUAL 2500 hrs	ANNUAL 5000 hrs
1.	Remove water pump from unit and check: Water pump impeller retaining bolt/nut for security and for damage or contact to the impeller, Impeller keyways for wear and security, shaft bearings for signs of heating and wear, drive end shaft keyways for signs of damage and heating and seals for security, damage and over or under lubrication. Check volute case for damage or contact. Check both of the impeller wear rings for damage and excessive wear (0.5 mm nominal tolerance) Check packing mount for security. (Disassembly of water pump is required to perform these maintenance operations). Repair as required.						X
2.	Check shaft seals for excessive lubricant leakage and water leakage. Lubricate water pump with a manual grease gun only. When lubricating the drive motor side shaft bearing and the impeller end bearing, apply 16 to 20 squirts (injections) of grease (60 cc) to each. Apply 4 or 5 squirts (injections) of grease to lantern ring grease fitting. Adjust, repair or replace as required.		X				
3.	Check water pump and drive motor for leaks, excessive vibration/noise leaks and evidence of excessive heating. Repair as required.	X					
4.	Check rope seals for excessive water leakage, compression, wear and overheating. Adjust rope packing seal packing gland or replace rope packing seals as required.	X					
5.	Check water pump inlet and discharge piping for security, leakage and misalignment. Repair leaks as required.		X				

ADDENDUM 1.2 TABLE 3 - TYPICAL SAFETY CRITICAL PARTS

SAFETY CRITICAL PARTS FOR PERIODIC REPLACEMENT ITEM 1 - 18000 L WATER TANKER		REPLACEMENT INTERVAL	REMARKS
1.	Fuel hose (fuel tank - injection pump)	Every 4000 hours or 2 years, whichever comes sooner	
2.	Fuel hose (injection pump - fuel tank)		
3.	Spill hose (engine output connector - fuel tank)		
4.	Water separator (case, O-ring, plug)		
5.	Rubber hose for brake piping		
6.	High-pressure hose in steering oil pressure circuit (pump ↔ demand valve ↔ steering valve ↔ steering cylinder)		
7.	High-pressure hose in hoist circuit (pump ↔ demand valve ↔ hoist valve ↔ hoist cylinder)		
8.	Hose at discharge side of retarder cooling pump		
9.	Hose at discharge side of transmission pump		
10.	High-pressure hose in brake control circuit (pump ↔ accumulator charge valve ↔ accumulator)	Every 2000 hours or 1 year, whichever comes sooner	Replace as service kit
11.	Brake valve parts		
12.	Parking brake valve parts		
13.	Accumulator charge valve parts		
14.	Retarder control valve parts		
15.	Parking brake chamber parts		
16.	Slack adjuster parts	Every three years	Replace
17.	Seat belt		

ITEM 2 – CONTAINER CARRYING ARTICULATED DUMP TRUCK

TRACTOR OEM		CONTAINER SUBFRAME OEM	
TRACTOR MODEL		SUBFRAME MODEL	
COUNTRY OF ORIGIN		COUNTRY OF ORIGIN	

NO	(1)	DESCRIPTION (2)	COMPLY? (3)	CLARITY / BROCHURE (4)
		ITEM 2 – CONTAINER CARRYING ARTICULATED DUMP TRUCK	YES / NO	REFERENCE INFO
1		SPECIFICATION SUMMARY		
1.1		A heavy duty three - axle diesel powered, centrally articulated tractor in 6X6 configuration fitted with a sub frame designed to carry and tip a 6m container. The residual payload capacity carried in the container must not be less than 23 000 kg.
1.2		Standard 6m containers filled with industrial and residential waste from the City of Cape Town's waste transfer stations will be brought to the landfill site where they will be offloaded onto the articulated tractors trailer sub frame.
1.3		The tractor chassis offered as well as the matching trailer sub frame and twist lock arrangements required for standard 6 m container must be a proven robust proprietary brand, of the latest design and material construction for operation off the highway on uneven, rough terrain.
1.4		Clearly <u>highlighted</u> original OEM brochures describing in detail the articulated tractor and container holding frame combinations adherence to this technical specification, must be submitted with tender submission or as and when required by the City of Cape Town's technical evaluation team.
1.5		The entire tender document must be scanned in searchable PDF format and submitted on a flash drive along with the tender document. Scanning in jpg format is not acceptable.
2		TENDERERS GUIDE		
2.1		The tenderer is to carefully scrutinize each clause and fill in the document as follows:-
2.2		Full compliance to the requirement of the technical specification clause must be indicated by the word "Yes" or "No" in column 3.
2.3		If a required item is standard fitment, then the word "Standard" may be written in column 4 in addition to the "Yes" in column 3.

NO (1)	DESCRIPTION (2) ITEM 2 – CONTAINER CARRYING ARTICULATED DUMP TRUCK	COMPLY? (3) YES / NO	CLARITY / BROCHURE (4) REFERENCE INFO
2.4	In the case of “No” being entered the tenderer may offer an explanation in the column 4.
2.5	Where specific data is required, this may be cross referenced in column 4 to an OEM brochure page number and then the respective clauses highlighted / underlined in such named brochures for ease of evaluation.
3	MAINTENANCE AND SERVICING FACILITIES		
3.1	The tenderer must either have or have access to, accredited and fully equipped facilities within the boundaries of City of Cape Town area which are OEM approved for the maintenance, repairs including structural, hydraulic, diagnostics and major component overhauls of the articulated truck chassis and container holding / tipping frame offered.
3.2	ARTICULATED TRACTOR MAINTENANCE		
3.2.1	Maintenance Facility Address GPS Co-ordinates	S° '" E° '"
3.3	CONTAINER HOLDING / TIPPING SUBFRAME		
3.3.1	Maintenance Facility Address GPS Co-ordinates	S° '" E° '"
3.3.2	<p>a) Tenderers must provide either a letter from the OEM or a copy of the Service Level Agreement (SLA) with their service provider indicating that: -</p> <p>b) the facilities offered are OEM approved for the maintenance, repair, hydraulic, diagnostic testing and major overhauls of the articulated truck chassis and container holding frame combination offered while under warranty.</p> <p>c) Tenderers who do not to have access to established OEM accredited facilities must refer to 36.1 of the Special Conditions of Contract for guidance if they wish to participate in this tender.</p> <p>d) In this context the tenderer is pay attention to the requirements of the Condition of Tender clauses 2.2.1.1.8. to 2.2.1.1.11</p>
4	DEFINITIONS		
4.1	The complete tractor and container holding sub frame / tipping combination will be referred to as the “vehicle” in the technical specification.

NO (1)	DESCRIPTION (2) ITEM 2 – CONTAINER CARRYING ARTICULATED DUMP TRUCK	COMPLY? (3) YES / NO	CLARITY / BROCHURE (4) REFERENCE INFO
5	APPLICABLE STANDARDS		
5.1	The articulated tractor and trailer must conform to the following standards		
5.2	SANS 1517:2005: - Lubricating oil diesel engines
5.3	SANS 10281:2003 - Sound levels
5.4	SANS 20049:2009 - Particulate pollutants engines (ECE R49.02B)
5.5	SANS 10168:2002 - Restraining devices (safety belts) in vehicles
5.6	SANS 12944-4:2023 - Paints and varnishes – Corrosion protection of steel structures by protective paint systems – Part 4: Types of surface and surface preparation
5.7	SANS 12944-5:2023 - Paints and varnishes – Corrosion protection of steel structures by protective paint systems – Part 5: Protective paint systems.
5.8	SANS 12944-7:2023 - Paints and varnishes – Corrosion protection of steel structures by protective paint systems – Part 7: Execution and supervision of paint work. D
5.9	ISO 9533: - Audible warning systems
5.10	IEC 60529 IP66 - Ingress protection rating – water and dust
5.11	ISO 3471:2008 - Earth-moving machinery - Roll-over protective structures
5.12	ISO 3449:2005:- Earth-moving machinery - Falling-object protective structures
5.13	Addendum 13B : General Technical Specifications
6	CHASSIS		
6.1	The chassis (tractor, trailer and the container holding / tipping sub frame) is to be constructed from high-strength, welded-alloy steel and all articulation joints reinforced according to OEM standards.
6.2	The machine shall have an articulated chassis with full hydraulic power steering.
6.3	a) The central oscillation joint shall be a sealed and maintenance free type with permanently greased tapered roller bearings to allow independent movement of the tractor and water tanker without frame twist, whilst providing for good ground contact in rough landfill site conditions.

NO (1)	DESCRIPTION (2) ITEM 2 – CONTAINER CARRYING ARTICULATED DUMP TRUCK	COMPLY? (3) YES / NO	CLARITY / BROCHURE (4) REFERENCE INFO
	b) Other proprietary oscillation joint designs with the same functionality will however also be accepted.
6.4	The vehicle must be fitted with under-side protection guards (6mm minimum thickness mild steel plate) under the engine and transmission compartments, as well as driveline protection
6.5	The chassis is to incorporate a centralised easily accessible lubrication bank for ease of greasing remote and hard to reach points.
6.6	The diesel tank must be positioned for maximum ground clearance
6.7	All fuel tank caps and battery boxes must be lockable
6.8	a) The container holding / tipping frame complete with twist locks shall be mounted onto the trailer according to the OEM body builders' instructions. b) Excerpts from the body builders manual will be required to validate such fitment.
6.9	See Addendum 2.1 for a basic layout of the vehicle.
7	ENGINE		
7.1	The tractor must be equipped with a turbocharged common rail diesel engine delivering a maximum net output of not less than 200 kW and maximum net torque of not less than 1000 Nm measured to SANS 10013-1: 2006 standards.
7.2	Make and model Capacity Maximum Output (Kw @ rpm) @ Sea level Maximum Torque (Nm @ rpm) @ Sea levelcc ³kWrpmNmrpm
7.3	The vehicle emissions under start up and operating conditions shall comply with the International Euro 2 standard as a minimum. Euro Standard
7.4	Engine performance curves must be shown in technical brochures.
7.5	The engine is required to operate on proprietary brand lubricating oil to the current applicable standards and in use in the heavy vehicle industry in South Africa.
7.6	The engine oil dipstick, fill point, oil and fuel and any particulate filters, and coolant reservoir are to be readily accessible for ease of maintenance.
7.7	The air cleaner fitted must be of the two-stage dry type, incorporating automatic intermittent self-cleaning action

NO (1)	DESCRIPTION (2) ITEM 2 – CONTAINER CARRYING ARTICULATED DUMP TRUCK	COMPLY? (3) YES / NO	CLARITY / BROCHURE (4) REFERENCE INFO
	and preferably be of South African manufacture.
7.8	The engine and gearbox oil drains must be in easily accessible positions to facilitate emptying without the risk of polluting the environment.
7.9	ENGINE PROTECTION UNIT (E.P.U.)		
7.9.1	The articulated tractor shall incorporate a failsafe mechanical engine monitoring system which monitors: - - oil pressure; - water temperature; - water level; - engine speed
7.9.2	In the event of a fault condition the EPU shall immediately cut out the engine or decrease engine revs to idle and keep the engine in this state until the fault condition is attended to.
7.9.3	The service plan is to include the necessary periodic inspection and servicing of all sensors according to OEM requirements
7.10	TURBO PROTECTION SYSTEM		
7.10.1	A proprietary protection system shall be fitted to prevent damage to the turbo charger in the event the engine is switched off prematurely, "Turboprotect" or equivalent.
7.11	RADIATOR PROTECTION		
7.11.1	a) The radiator is to be protected by a proprietary brand pre filter screen fitted in a radiator guard panel to protect the fins from being clogged by fine particles / dust such as is found at a landfill site. b) Airflow through the pre-filter must be at the correct OEM prescribed level for proper radiator cooling. c) The panel is to be easily removed for purposes of cleaning.
8	TRANSMISSION		
8.1	The vehicle may be powered by: - a) A complete hydrostatic drive transmission or b) An automatic power-shift transmission and matched torque converter or c) Fully automatic transmission with matched torque converter d) Transmission control modules / shift inhibitor to prevent driveline shock loading must be incorporated

NO (1)	DESCRIPTION (2) ITEM 2 – CONTAINER CARRYING ARTICULATED DUMP TRUCK	COMPLY? (3) YES / NO	CLARITY / BROCHURE (4) REFERENCE INFO
	where necessary.
8.2	Engine and transmission diagnostics must be possible via connection to a laptop from the vehicles diagnostic port.
9	BRAKES		
9.1	Full details of service brakes, parking brakes, auxiliary brakes and any independent emergency parking brake must be submitted in brochures.
10	STEERING		
10.1	The steering system is to comprise double acting cylinders, with a ground driven emergency steering pump in the event of engine cut out or main hydraulic circuit failure.
10.2	Steering angle in each direction shall be at least 45 degrees
11	WHEELS AND TYRES		
	a) The vehicle must be fitted with suitably sized OTR steel radial tyres, preferably of South African manufacture no smaller than 23.5 R 25 and L4 rated.
	b) The size and ratings must be freely available within the geographical boundaries of the City of Cape Town.
12	ELECTRICAL SYSTEM		
12.1	The electrical system shall be 24V with deep cycle heavy duty batteries fitted, AGM (Absorption Glass Mat) type or equivalent.
12.2	The alternator must not be rated less than 50 Amp
12.3	The battery compartment must be lockable and tamper proof.
12.4	All electrical wiring connectors must be automotive double-seal type, with wiring in split convoluted looms.
12.5	An audible reverse warning beeper with an audio output of not less than 90 dB measured at 1 meter be fitted if not supplied as standard fitment.
12.6	An anti-theft system, Vesa approved, must be fitted to prevent unauthorized engine starting.
12.7	A master disconnect switch must be available at ground switch.
12.8	LIGHTING		
12.8.1	Please refer to Addendum 13 B clause 13.8 for clarity on LED light fitment. This will apply to any LED lighting		

NO (1)	DESCRIPTION (2) ITEM 2 – CONTAINER CARRYING ARTICULATED DUMP TRUCK	COMPLY? (3) YES / NO	CLARITY / BROCHURE (4) REFERENCE INFO
	supplied as standard on the vehicle.
12.8.2	The vehicle shall be fitted with a Class 1, Gen 111 (or better) LED type amber hazard light on the truck cab.
12.8.3	Class 1, Gen 111 (or better) LED type work lights, rated at least 20W output, shall be mounted on the front of the cab facing forward and on either side of the cab facing outwards
13	CAB		
13.1	The cab shall be weatherproof, lockable, with tinted safety glass windows which shall allow an unobstructed view of all operations.
13.2	The cab shall be ROPS (roll over protection) and FOPS (falling object) protected and shall be installed on anti-vibration mounts onto the chassis.
13.3	The vehicle suspension type must be selected to minimise vibration transmitted to the cab.
13.4	Noise level measured at the driver's ear shall be less than 80 Db(A)
13.5	The operator's seat shall be a heated, air suspension type and be adjustable for rake, position and the mass of the operator, and shall be cushioned and upholstered in durable material. Padded armrests shall be fitted
13.6	Driver seatbelt and passenger seatbelt (if applicable) shall be fitted
13.7	Adequate front and rear wipers and washers shall be fitted
13.8	A proprietary brand AM / FM radio with auxiliary and USB inputs as well as blue tooth functionality, shall be fitted in the event that the vehicle is not supplied with one as a standard fitment.
13.9	The cab shall be fitted with a proprietary brand HVAC climate control system if not a standard fitment.
13.10	The cab shall be fitted with a high efficiency particulate air (HEPA) filter system designed to trap microscopic pollutants including pollen, mould and common allergens
13.11	If an hour meter is not offered as standard, then: - a) A non-tamper proof digital hour meter (Hella or equivalent) logging engine hours must be mounted in a convenient and easily visible position on dashboard b) The instrument must have a metering capacity of 9999 hrs with a digital readout of 1/10 th of an hour.

NO (1)	DESCRIPTION (2) ITEM 2 – CONTAINER CARRYING ARTICULATED DUMP TRUCK	COMPLY? (3) YES / NO	CLARITY / BROCHURE (4) REFERENCE INFO
	c) The meter must be connected to the alternator circuit.
13.12	a) A proprietary brand reversing camera system with colour LCD monitor shall be installed in the cab “LiftCam HD” or equivalent is to be installed.
14	HYDRAULIC SYSTEM		
14.1	The hydraulic system is to accommodate a full load sensing system feeding the internal hydraulic functions.
14.2	A ground-driven, load sensing emergency steering pump is to be integrated into the main hydraulic system.
14.3	OIL CLEANLINESS		
14.3.1	The vehicle reservoirs must be filled oil to a classification ISO-L-HV in accordance ISO 6743 - 4, viscosity grade 46 hydraulic oil at a VI of at least 140. Shell Tellus S2 V46 or equivalent.
14.3.2	The cleanliness standards as set out in ISO 4406 and must be equal to or better than 18/16/14.
14.3.3	Under no circumstances must “new” oil be decanted directly from drums into the compactor reservoir without first going through an oil polishing unit to obtain the required cleanliness level.
14.3.4	The hydraulic oil tank shall incorporate easily accessible and replaceable spin on filters.
14.3.5	Hydraulic pressure check points are to be grouped together in an easily accessible position with standard hydraulic connection points where possible.
15	LUBRICATION		
15.1	Greasing lubrication ports must be located on the outside of the machine where practical without the need for crawling under the machine or into awkward unsafe positions.
16	CONTAINER HOLDING FRAME / SUB FRAME		
16.1	The container holding frame assembly shall be a proprietary brand i.e. professionally built for the particular articulated tractor chassis offered.
16.2	The frame shall be of sturdy construction with a low centre of gravity and section thicknesses adequate to safely hold at least 23 000 kg of industrial waste.

NO (1)	DESCRIPTION (2) ITEM 2 – CONTAINER CARRYING ARTICULATED DUMP TRUCK	COMPLY? (3) YES / NO	CLARITY / BROCHURE (4) REFERENCE INFO
16.3	a) The frame must be professionally designed using proprietary stress analysis methods, and mechanically strengthened where high stress concentration points occur and so that the container is stable while mounted, under gusty wind loading conditions such as is found at the various City of Cape Town landfill sites in the Western Cape. b) Dynamic loading caused by the unevenness of the landfill site must also be taken into consideration.
16.4	The sub frame must be fitted with two suitably sized hydraulic rams to tip the container to approximately 55 degrees to expel the container contents.
16.5	a) The frame shall be fitted with four adjustable levelling brackets to support the frame while loading the articulated tractor with the container. b) The levelling brackets shall be placed at suitable locations on the ends of the holding frame.
17	SPARES HOLDING		
	a) The tenderer shall guarantee here the availability of a full range of spare parts (running and critical), ex stock for the vehicle within the geographical boundaries of the City of Cape Town. b) Any limitation to the availability shall be explained in a covering letter attached to the tender documents.
17.1	TRACTOR		
17.1.1	Tenderers shall state the location of spare parts. <div style="text-align: right;"> Running spares (Same day) Mechanical / driveline spares Body components (interior / exterior) </div>	LOCATION
17.2	CONTAINER CARRYING SUBFRAME		
17.2.1	Tenderers shall state the availability of spare parts and the location of the relevant parts. Any limitation to these requirements shall be explained in a covering letter. <div style="text-align: right;"> Running spares (Same day) Non critical spares </div>	LOCATION
18	WARRANTY		
18.1	VEHICLE		

NO (1)	DESCRIPTION (2) ITEM 2 – CONTAINER CARRYING ARTICULATED DUMP TRUCK	COMPLY? (3) YES / NO	CLARITY / BROCHURE (4) REFERENCE INFO
18.1.1	The complete vehicle must be electrically, mechanically and structurally guaranteed for at least 5 years of operation.
18.2	CORROSION		
18.2.1	The complete vehicle shall have at least a 3 year corrosion protection warranty against body rust or paint defects, fair wear and tear excluded.
19	SERVICE PLAN		
19.1	SERVICE PLAN		
19.1.1	A service plan covering the complete vehicle and fitted accessories for the full warranty period of 5 year or 4000 hr must be offered.
19.1.2	<p>a) Full details of such service plans must be supplied with the tender document or as and when required by the City of Cape Town.</p> <p>b) See Addendum 2.2 for typical service schedules for the vehicle.</p>
20	OPTIONAL EXTRAS		
20.1	AUTO LUBE SYSTEM		
20.1.1	Supply and installation of a proprietary brand auto lube system for automatic greasing of bearings		
20.2	FIRE SUPPRESSION SYSTEM		
20.2.1	The tenderer is to offer a proprietary brand dual agent - DCP and aqueous film forming foam liquid fire suppressant system (Ansulite or similar) as an optional extra. The specified fire suppression system shall incorporate:-		
20.2.2	a) Sufficient and appropriately placed fire-detecting sensing manifold pipes.		
	b) A control panel in the cab to detect a fire and alert the operator		
	c) Actuators to discharge suppressant automatically and manually		
	d) Tanks filled with fire suppressant DCP and aqueous film forming foam (Ansulite or similar)		
	e) Distribution network of tubes, hoses, and nozzles		
20.2.3	It is essential that fitment of the fire suppression system be done by a registered qualified artisan / technician in terms of South African legislation set out in this regard.		

NO (1)	DESCRIPTION (2) ITEM 2 – CONTAINER CARRYING ARTICULATED DUMP TRUCK	COMPLY? (3) YES / NO	CLARITY / BROCHURE (4) REFERENCE INFO
20.2.4	The fire suppression system shall carry a 3 year warranty from the date of handover.		
20.2.5	The City of Cape Town reserves the right to view the tenderers compliance in this regard as and when it deems it fit to do so.		
20.3	WEST COAST CORROSION PROTECTION		
20.3.1	The tenderer has to ensure that the corrosion protective coating is of a type suitable for a South African coastal environment. i.e. Carbo-mastic spec or equivalent		
20.3.2	Paint coatings chosen shall have the same UV, abrasion and corrosion resistance as the following paint program or better :-		
a)	Abrasive Blast Cleaning. A Class 2½ “Near White Metal” blast cleanliness, metal preparation.		
b)	A proprietary brand two-pack epoxy zinc rich primer for cathodic resistance in harsh corrosive environments		
c)	A proprietary brand two-component high gloss acrylic polyurethane top coat		
d)	The paint offered shall have at least a 5 year corrosion protection following marine quality international standard i.e. Carbo-mastic spec or equivalent.		
e)	The above paints are to be applied in accordance with the manufacturer's recommendations. The Contractor shall arrange for a suitable inspection authority to attend to each stage, approve and submit a report on the application		
21	MANUALS AND TRAINING		
21.1	Properly bound, original approved OEM operators, service and parts manuals in the English language must be provided on delivery.
21.2	a) Training for operators in the proper operation of the vehicle must be provided and included in the tendered price. b) Training for 4 candidates must be provided within two weeks of delivery of the vehicle or as and when required by the City of Cape Town
22	DELIVERY		
22.1	The vehicle shall be registered in the name of the City of Cape Town.
22.2	The cost of licensing, registration, number plates, etc. must be included in the price of the vehicle

NO (1)	DESCRIPTION (2) ITEM 2 – CONTAINER CARRYING ARTICULATED DUMP TRUCK	COMPLY? (3) YES / NO	CLARITY / BROCHURE (4) REFERENCE INFO
22.3	The vehicle shall have permanent manufacturers plates whereupon relevant data is stamped i.e. the manufacturers name, model no, serial number, and year of manufacture. The plates are to be fixed as per OEM instructions.
22.4	The delivery cost must form part of the main item in the pricing schedule. The transportation of the vehicle must adhere to legal and safety regulations applicable.
22.5	Essential operator tools including wheel spanner and heavy duty hand held grease gun etc. to allow the operator to perform running maintenance is required.
22.6	State whether any free services are included in the tendered price and where such services will be carried out.
22.7	Pre- delivery service cost must be included in the tender price
22.8	Any unacceptable delays in delivery ensuing will attract prescribed penalties.

ADDENDUM 2.1

OUTLINE OF THE TYPE OF VEHICLE REQUIRED SHOWING THE CONTAINER
(Not to be construed as the actual brand of vehicle required)



ADDENDUM 2.2

TYPICAL MAINTENANCE AND SERVICING SCHEDULES

The maintenance and service schedules **shall** include all the recommended OEM items for the particular item of plant under consideration. The tables below are not to be construed as complete lists but is merely an indication of the type of service required. The OEM maintenance and service book items shall at all times take preference and must be adhered to.

NO	DRIVELINE ITEM 2 - CONTAINER CARRYING ADT	Daily	100 hrs	250 hrs	500 hrs	1000 hrs	2000 hrs	3000 hrs	As Required
ENGINE									
1.	Adjust the valve clearance		X		X				
2.	Change the primary fuel filter		X			X			
3.	Change the secondary fuel filter					X			
4.	Change the oil and oil filters		X	X					
5.	Change the crankcase breather							X	
6.	Change the air cleaner secondary filter						X		
7.	Change the coolant						X		
8.	Check the oil level	X							
9.	Check the coolant level	X							
10.	Check the coolant specification								X
11.	Check drive belts tension			X					
12.	Check engine compartment components								X
13.	Check air cleaner primary filter								X
14.	Clean pre cleaner assembly								X
15.	Drain the primary fuel filter								X
16.	Flush and renew the coolant						X		
17.	Service injectors							X	
GEARBOX									
1.	Change filters					X			
2.	Change oil					X			
3.	Check oil level	X							
HYDRAULICS									
1.	Change oil						X		
2.	Change filters		X					X	
3.	Check breather filter					X			
4.	Check oil level	X							
CHASSIS AND AXLES									
1.	Change oil in differentials and final drives		X				X		
2.	Check oil level in differentials/final drives			X					
3.	Check service brake pads				X				
4.	Check park brake pads				X				

NO	DRIVELINE ITEM 2 - CONTAINER CARRYING ADT	Daily	100 hrs	250 hrs	500 hrs	1000 hrs	2000 hrs	3000 hrs	As Required
5.	Check wheel nuts								
CAB, PNEUMATICS AND ELECTRICAL									
1.	Change the air drier filter					X			
2.	Check operator controls and instruments	X							
3.	Check working lights, reverse buzzer, horn	X							
4.	Check electrical connections			X					
LUBRICATION									
1.	Grease hinges					X			
2.	Grease prop shafts						X		
3.	Grease the through drive bearing					X			
4.	Grease the PTO prop shaft					X			
5.	Grease lubrication points	X							

NO	CONTAINER SUBFRAME ITEM 2 - CONTAINER CARRYING ADT	WEEKLY 150 hrs	BI WEEKLY 250 hrs	MONTHLY 500 hrs	QUARTERLY 1000 hrs	BI ANNUAL 2500 hrs	ANNUAL 5000 hrs
SUBFRAME							
1.	Check sub frame for damaged components. Evidence of severe corrosion.			X			X
2.	Check for any weld cracking.			X			
TWISTLOCKS							
1.	Check for cracks and/or deformation on housing and locking device						X
2.	Malfunction of locking device (not rotating properly). Loose screws, springs damaged.						X
3.	Damaged or missing components.						X
4.	Evidence of severe corrosion						X
CONTAINER TIPPER HYDRAULICS							
1.	Check hydraulic fluid levels and colour as an indication of cleanliness.			X			
2.	Check all hydraulic filters for contamination.				X		
3.	Inspect hydraulic rams / rods for signs of stress and wear and corrosion.				X		
4.	Inspect system component seals and fluid lines for leaks.				X		
5.	Check supply hoses and shutoff valve for security condition and evidence of suction leaks.				X		
6.	Inspect hydraulic cylinder tubes for signs of ballooning. Perform a piston seal by pass test.				X		

NO	CONTAINER SUBFRAME ITEM 2 - CONTAINER CARRYING ADT	WEEKLY 150 hrs	BI WEEKLY 250 hrs	MONTHLY 500 hrs	QUARTERLY 1000 hrs	BI ANNUAL 2500 hrs	ANNUAL 5000 hrs
7.	Check all ram support brackets, ball joints, clevises, rod eyes and other connections for distortion or wear.						

ITEM 3 – HOOKLIFT ADT 25 TON

TRACTOR OEM		HOOKLIFT OEM	
TRACTOR MODEL		HOOKLIFT MODEL	
COUNTRY OF ORIGIN		COUNTRY OF ORIGIN	

NO (1)	DESCRIPTION (2)	COMPLY? (3) YES / NO	BROCHURE REFERENCE INFO (4)
1	ITEM 3 – ADT WITH HOOKLIFT 25 TON		
	SPECIFICATION SUMMARY		
1.1	A heavy duty three - axle diesel powered, centrally articulated tractor in 6X6 configuration fitted with a hook lift and sub frame designed to carry a 6m container. The residual payload capacity carried in the container must not be less than 23 000 kg.
1.2	The 6m containers filled with industrial and residential waste from the City of Cape Town’s waste transfer stations will be brought to the landfill site where they will be loaded onto the articulated tractors trailer sub frame by means of the integral hook lift.
1.3	The tractor chassis offered as well as the matching trailer sub frame and hook lift arrangement required for the 6m container must be a proven robust proprietary brand, of the latest design and material construction for operation off the highway on uneven, rough terrain.
1.4	Clearly <u>highlighted</u> original OEM brochures describing in detail the articulated tractor and container holding frame combinations adherence to this technical specification, must be submitted with tender submission or as and when required by the City of Cape Town’s technical evaluation team.
1.5	The entire tender document must be scanned in searchable PDF format and submitted on a flash drive along with the tender document. Scanning in jpg format is not acceptable.
2	TENDERERS GUIDE		
2.1	The tenderer is to carefully scrutinize each clause and fill in the document as follows:-
2.2	Full compliance to the requirement of the technical specification clause must be indicated by the word “Yes” or “No” in column 3.
2.3	If a required item is standard fitment, then the word “Standard” may be written in column 4 in addition to the “Yes” in column 3.

NO (1)	DESCRIPTION (2) ITEM 3 – ADT WITH HOOKLIFT 25 TON	COMPLY? (3) YES / NO	BROCHURE (4) REFERENCE INFO
2.4	In the case of “No” being entered the tenderer may offer an explanation in the column 4.
2.5	Where specific data is required, this may be cross referenced in column 4 to an OEM brochure page number and then the respective clauses highlighted / underlined in such named brochures for ease of evaluation.
3	MAINTENANCE AND SERVICING FACILITIES		
3.1	The tenderer must either have or have access to, accredited and fully equipped facilities within the boundaries of City of Cape Town area which are OEM approved for the maintenance, repairs including structural, hydraulic, diagnostics and major component overhauls of the articulated truck chassis and container holding frame offered.
3.2	ARTICULATED TRACTOR MAINTENANCE		
3.2.1	Maintenance Facility Address GPS Co-ordinates	S° '" E° '"
3.3	CONTAINER HOLDING SUBFRAME		
3.3.1	Maintenance Facility Address GPS Co-ordinates	S° '" E° '"
3.3.2	<p>a) Tenderers must provide either a letter from the OEM or a copy of the Service Level Agreement (SLA) with their service provider indicating that: -</p> <p>b) the facilities offered are OEM approved for the maintenance, repair, hydraulic, diagnostic testing and major overhauls of the articulated truck chassis and container holding frame combination offered while under warranty.</p> <p>c) Tenderers who do not to have access to established OEM accredited facilities must refer to 36.1 of the Special Conditions of Contract for guidance if they wish to participate in this tender.</p> <p>d) In this context the tenderer is pay attention to the requirements of the Condition of Tender clauses 2.2.1.1.8. to 2.2.1.1.11</p>
4	DEFINITIONS		
4.1	The complete tractor and container holding sub frame / tipping combination will be referred to as the “vehicle” in the technical specification.

NO (1)	DESCRIPTION (2) ITEM 3 – ADT WITH HOOKLIFT 25 TON	COMPLY? (3) YES / NO	BROCHURE (4) REFERENCE INFO
5	APPLICABLE STANDARDS		
	The articulated tractor and trailer must conform to the following standards		
5.1	SANS 1517:2005: - Lubricating oil diesel engines
5.2	SANS 10281:2003 - Sound levels
5.3	SANS 20049:2009 - Particulate pollutants engines (ECE R49.02B)
5.4	SANS 10168:2002 - Restraining devices (safety belts) in vehicles
5.5	SANS 12944-4:2023 - Paints and varnishes – Corrosion protection of steel structures by protective paint systems – Part 4: Types of surface and surface preparation
5.6	SANS 12944-5:2023 - Paints and varnishes – Corrosion protection of steel structures by protective paint systems – Part 5: Protective paint systems.
5.7	SANS 12944-7:2023 - Paints and varnishes – Corrosion protection of steel structures by protective paint systems – Part 7: Execution and supervision of paint work. D
5.8	ISO 9533: - Audible warning systems
5.9	IEC 60529 IP66 - Ingress protection rating – water and dust
5.10	ISO 3471:2008 - Earth-moving machinery - Roll-over protective structures
5.11	ISO 3449:2005:- Earth-moving machinery - Falling-object protective structures
5.12	Addendum 13B : General Technical Specifications
6	CHASSIS		
6.1	The chassis (tractor, trailer and the container holding sub frame) is to be constructed from high-strength, welded-alloy steel and all articulation joints reinforced according to OEM standards.
6.2	The machine shall have an articulated chassis with full hydraulic power steering.

NO (1)	DESCRIPTION (2) ITEM 3 – ADT WITH HOOKLIFT 25 TON	COMPLY? (3) YES / NO	BROCHURE (4) REFERENCE INFO
6.3	a) The central oscillation joint shall be a sealed and maintenance free type with permanently greased tapered roller bearings to allow independent movement of the tractor and water tanker without frame twist, whilst providing for good ground contact in rough landfill site conditions. b) Other proprietary oscillation joint designs with the same functionality will however also be accepted.
6.4	The vehicle must be fitted with under-side protection guards (6mm minimum thickness mild steel plate) under the engine and transmission compartments, as well as driveline protection
6.5	The chassis is to incorporate a centralised easily accessible lubrication bank for ease of greasing remote and hard to reach points.
6.6	The tenderer is to offer an auto lubrication system for greasing such remote points as an optional extra.
6.7	The diesel tank must be positioned for maximum ground clearance
6.8	All fuel tank caps and battery boxes must be lockable
6.9	a) The container holding frame complete with twist locks shall be mounted onto the trailer according to the OEM body builder's instructions. b) Excerpts from the body builders manual will be required to validate such fitment.
6.10	See Addendum 3.1 for a basic sketch of the vehicle.
7	ENGINE
7.1	The tractor must be equipped with a turbocharged common rail diesel engine delivering a maximum net output of not less than 200 kW and maximum net torque of not less than 1000 Nm measured to SANS 10013-1: 2006 standards.
7.2	Make and model Capacity Maximum Output (Kw @ rpm) @ Sea level Maximum Torque (Nm @ rpm) @ Sea levelcc ³kWrpmNmrpm
7.3	The vehicle emissions under start up and operating conditions shall comply with the International Euro 2 standard as a minimum. Euro Standard
7.4	Engine performance curves must be shown in technical brochures.

NO (1)	DESCRIPTION (2) ITEM 3 – ADT WITH HOOKLIFT 25 TON	COMPLY? (3) YES / NO	BROCHURE (4) REFERENCE INFO
7.5	The engine is required to operate on proprietary brand lubricating oil to the current applicable standards and in use in the heavy vehicle industry in South Africa.
7.6	The engine oil dipstick, fill point, oil and fuel and any particulate filters, and coolant reservoir are to be readily accessible for ease of maintenance.
7.7	The air cleaner fitted must be of the two-stage dry type, incorporating automatic intermittent self-cleaning action and preferably be of South African Manufacture.
7.8	The engine and gearbox oil drains must be in easily accessible positions to facilitate emptying without the risk of polluting the environment.
7.9	ENGINE PROTECTION UNIT (E.P.U.)		
7.9.1	The articulated tractor shall incorporate a fail-safe mechanical engine monitoring system which monitors: - - oil pressure; - water temperature; - water level; - engine speed
7.9.2	In the event of a fault condition the EPU shall immediately cut out the engine or decrease engine revs to idle and keep the engine in this state until the fault condition is attended to.
7.9.3	The service plan is to include the necessary periodic inspection and servicing of all sensors according to OEM requirements
7.10	TURBO PROTECTION SYSTEM		
7.10.1	A proprietary protection system shall be fitted to prevent damage to the turbo charger in the event the engine is switched off prematurely, "Turboprotect" or equivalent.
8	RADIATOR		
8.1	The radiator shall be equipped with cooling fins spaced at an optimum OEM pitch, able to cool at an ambient temperature of up to 40 deg C.
8.2	The radiator is to be protected by a proprietary brand pre filter screen fitted in a radiator guard panel to protect the fins from being clogged by fine particles / dust such as is found at a landfill site.
8.3	Airflow through the pre-filter must be at the correct OEM prescribed level for proper radiator cooling.
8.4	The radiator guard panel is to be easily removed for purposes of cleaning.

NO (1)	DESCRIPTION (2) ITEM 3 – ADT WITH HOOKLIFT 25 TON	COMPLY? (3) YES / NO	BROCHURE (4) REFERENCE INFO
8.5	A reversing fan (or reversible fan) is to incorporated for periodic purging of debris.
8.6	Coolant drains must be placed in an easy to reach position to facilitate emptying without the risk of polluting the environment.
9	TRANSMISSION		
9.1	The vehicle may be powered by: - a) A complete hydrostatic drive transmission or b) An automatic power-shift transmission and matched torque converter or c) Fully automatic transmission with matched torque converter d) Transmission control modules / shift inhibitor to prevent driveline shock loading must be incorporated where necessary.
9.2	Engine and transmission diagnostics must be possible via connection to a laptop from the vehicles diagnostic port.
10	BRAKES		
10.1	Full details of service brakes, parking brakes, auxiliary brakes and any independent emergency parking brake must be submitted in brochures.
11	STEERING		
11.1	The steering system is to comprise double acting cylinders, with a ground driven emergency steering pump in the event of engine cut out or main hydraulic circuit failure.
11.2	Steering angle in each direction shall be at least 45 degrees
12	WHEELS AND TYRES		
12.1	a) The vehicle must be fitted with suitably sized OTR steel radial tyres, preferably of South African manufacture no smaller than 23.5 R 25 and L4 rated. b) The size and ratings must be freely available within the geographical boundaries of the City of Cape Town.
13	ELECTRICAL SYSTEM		
13.1	The electrical system shall be 24 volt incorporating deep cycle, AGM (absorption glass mat) type batteries.

NO (1)	DESCRIPTION (2) ITEM 3 – ADT WITH HOOKLIFT 25 TON	COMPLY? (3) YES / NO	BROCHURE (4) REFERENCE INFO
13.2	The alternator must not be rated less than 50 Amp
13.3	The battery compartment must be lockable and tamper proof.
13.4	All electrical wiring connectors must be automotive double-seal type, with wiring in split convoluted looms.
13.5	An audible reverse warning beeper with an audio output of not less than 90 dB measured at 1 meter be fitted if not supplied as standard fitment.
13.6	An anti-theft system, Vesa approved, must be fitted to prevent unauthorized engine starting.
13.7	A master disconnect switch must be available at ground switch.
13.8	LIGHTING		
13.8.1	Please refer to Addendum 13 B clause 13.8 for clarity on LED light fitment. This will apply to any LED lighting supplied as standard on the vehicle.
13.8.2	An audible reverse warning beeper with OEM approved LED type reverse light, must be supplied as standard fitment.
13.8.3	The vehicle shall be fitted with a Class 1, Gen 111 (or better) LED type amber hazard beacon on the truck cab.
13.8.4	Class 1, Gen 111 (or better) LED type work lights, rated at least 20W output, shall be mounted on the front of the cab facing forward and on either side of the cab facing outwards.
14	CAB		
14.1	The cab shall be weatherproof, lockable, with tinted safety glass windows which shall allow an unobstructed view of all operations.
14.2	The cab shall be ROPS (roll over protection) and FOPS (falling object) protected and shall be installed on anti-vibration mounts onto the chassis.
14.3	The vehicle suspension type must be selected to minimise vibration transmitted to the cab.
14.4	Noise level measured at the driver's ear shall be less than 80 Db(A)
14.5	The operator's seat shall be a heated, air suspension type and be adjustable for rake, position and the mass of the operator, and shall be cushioned and upholstered in durable material. Padded armrests shall be fitted

NO (1)	DESCRIPTION (2) ITEM 3 – ADT WITH HOOKLIFT 25 TON	COMPLY? (3) YES / NO	BROCHURE (4) REFERENCE INFO
14.6	Driver seatbelt and passenger seatbelt (if applicable) shall be fitted
14.7	Adequate front and rear wipers and washers shall be fitted
14.8	A proprietary brand AM / FM radio with auxiliary and USB inputs as well as blue tooth functionality, shall be fitted in the event that the vehicle is not supplied with one as a standard fitment.
14.9	The cab shall be fitted with a proprietary brand HVAC climate control system if not a standard fitment.
14.10	The cab shall be fitted with a high efficiency particulate air (HEPA) filter system designed to trap microscopic pollutants including pollen, mould and common allergens
14.11	If an hour meter is not offered as standard, then: - a) A non-tamper proof digital hour meter (Hella or equivalent) logging engine hours must be mounted in a convenient and easily visible position on dashboard b) The instrument must have a metering capacity of 9999 hrs with a digital readout of 1/10 th of an hour. c) The meter must be connected to the alternator circuit.
14.12	A proprietary brand reversing camera system with colour LCD monitor shall be installed in the cab "LiftCam HD" or equivalent is to be installed.
15	HYDRAULIC SYSTEM		
15.1	a) The hydraulic system is to accommodate a full load sensing system feeding the essential hydraulic functions. b) A ground-driven, load sensing emergency steering pump is to be integrated into the main hydraulic system.
15.2	OIL CLEANLINESS		
15.2.1	The refuse compactors reservoirs must be filled oil to a classification ISO-L-HV in accordance ISO 6743 - 4, viscosity grade 46 hydraulic oil at a VI of at least 140. Shell Tellus S2 V46 or equivalent.
15.2.2	The cleanliness standards as set out in ISO 4406 and must be equal to or better than 18/16/14.

NO (1)	DESCRIPTION (2) ITEM 3 – ADT WITH HOOKLIFT 25 TON	COMPLY? (3) YES / NO	BROCHURE (4) REFERENCE INFO
15.2.3	Under no circumstances must “new” oil be decanted directly from drums into reservoirs without first going through an oil polishing unit to obtain the required cleanliness level.
15.2.4	The hydraulic oil tank shall incorporate easily accessible and replaceable spin on filters.
16	LUBRICATION		
16.1	Greasing lubrication ports must be located on the outside of the machine where practical without the need for crawling under the machine or into awkward unsafe positions.
17	HOOK LIFT		
17.1	The hook lift comprising the following main parts is to be a <u>proven proprietary brand</u> : - a) The tipping frame b) The main arm frame c) The pick-up hook d) The locking system e) Tipping rams f) The hydraulic system g) Control system including load sensors.
17.2	The hook lift assembly fitted to the ADT must have adequate strength and section thicknesses to safely load a 6m container with compacted waste totalling approximately 23 000 kg onto the holding / tipping frame.
17.3	The hook lift is to be powered by a suitable PTO and gear pump arrangement with appropriately sized rams and is to be capable of mounting a containerized load totalling approximately 23 metric tons, tipping and demounting.
17.4	The hook lift must be constructed of high tensile steel and in high abrasion / wear stressed areas, steels such as Hardox 450 or equivalent is expected to be used.
17.5	The hook lift is to be structurally stable while in operation, under the gusty wind loading conditions such as is found at the various City of Cape Town landfill sites in the Western Cape.
17.6	The hook lift must incorporate dual articulation technology for smooth dumping and loading operations.
17.7	The hook lift is to incorporate a hydraulic telescoping jib to allow positioning of the container on the holding frame for better weight distribution.
17.8	The hook lift holding frame must have an approved locking system to secure the container.

NO (1)	DESCRIPTION (2) ITEM 3 – ADT WITH HOOKLIFT 25 TON	COMPLY? (3) YES / NO	BROCHURE (4) REFERENCE INFO
17.9	The hook lift holding frame shall be fitted with adjustable levelling jacks / brackets to support the trailer rear wheels while loading the container if the hook lift / vehicle OEM requires this.
17.10	The hook lift sub frame must be fitted with dual hydraulic rams to load and tip the container. The tipping angle is approximately 50 degrees.
17.11	a) The hook lift hydraulic control system is to be designed to reduce hydraulic speed to settle the container gently onto the chassis after loading and dumping to protect the hook lift, container and vehicle. b) The hydraulic control system must include all the necessary standard protection devices to allow smooth operation of the rams without any shock loading or damage to the hook or sub frame assembly.
17.12	The tenderer is to include in cab controls as well as external controls in the tenderers price.
17.13	The hook must be dismountable in order to replace it if worn out or damaged.
18	SPARES HOLDING		
	a) The tenderer shall guarantee here the availability of a full range of spare parts (running and critical), ex stock for the vehicle within the geographical boundaries of the City of Cape Town. b) Any limitation to the availability shall be explained in a covering letter attached to the tender documents.
18.1	TRACTOR		
18.1.1	Tenderers shall state the location of spare parts. Running spares (Same day) Mechanical / driveline spares Body components (interior / exterior)	LOCATION
18.2	HOOKLIFT ASSEMBLY		
18.2.1	Tenderers shall state the availability of spare parts and the location of the relevant parts. Any limitation to these requirements shall be explained in a covering letter. Running spares (Same day) Non critical spares	LOCATION
19	CORROSION PROTECTION		

NO (1)	DESCRIPTION (2) ITEM 3 – ADT WITH HOOKLIFT 25 TON	COMPLY? (3) YES / NO	BROCHURE (4) REFERENCE INFO
19.1	The tenderer has to ensure that the protective coating is of a type suitable for a South African coastal environment.
19.2	Paint coatings chosen shall have the same UV, abrasion and corrosion resistance as the following paint program or better :-
19.2.1	Abrasive Blast Cleaning. A Class 2½ "Near White Metal" blast cleanliness, metal preparation.
19.2.2	A proprietary brand two-pack epoxy zinc rich primer for cathodic resistance in harsh corrosive environments
19.2.3	A proprietary brand two-component high gloss acrylic polyurethane top coat
20	WARRANTY		
20.1	VEHICLE		
20.1.1	The complete tractor and trailer must be electrically, mechanically and structurally guaranteed for at least 5 years
20.2	HOOKLIFT ASSEMBLY		
20.2.1	The complete hook lift assembly must be fully guaranteed for at least 3 years.
21	SERVICE PLAN		
21.1	SERVICE PLAN		
21.1.1	A service plan covering the complete vehicle and fitted accessories for the full warranty period of 5 year or 4000 hr must be offered.
21.1.2	a) Full details of such service plans must be supplied with the tender document or as and when required by the City of Cape Town. b) See Addendum 3.2 for typical service schedules for the vehicle.
22	OPTIONAL EXTRAS		
22.1	AUTO LUBE SYSTEM		
22.1.1	If not standard with offer, the tenderer is to offer an auto lubrication system for greasing such remote points.
22.2	FIRE SUPPRESSION SYSTEM		

NO (1)	DESCRIPTION (2) ITEM 3 – ADT WITH HOOKLIFT 25 TON	COMPLY? (3) YES / NO	BROCHURE (4) REFERENCE INFO
22.2.1	The tenderer is to offer a proprietary brand dual agent - DCP and aqueous film forming foam liquid fire suppressant system (Ansulite or similar). The specified fire suppression system shall incorporate:-		
22.2.2	a) Sufficient and appropriately placed fire-detecting sensing manifold pipes.		
	b) A control panel in the cab to detect a fire and alert the operator		
	c) Actuators to discharge suppressant automatically and manually		
	d) Tanks filled with fire suppressant DCP and aqueous film forming foam (Ansulite or similar)		
	e) Distribution network of tubes, hoses, and nozzles		
22.2.3	It is essential that fitment of the fire suppression system be done by a registered qualified artisan / technician in terms of South African legislation set out in this regard.		
22.2.4	The fire suppression system shall carry a 3 year warranty from the date of handover.		
22.2.5	The City of Cape Town reserves the right to view the tenderers compliance in this regard as and when it deems it fit to do so.		
22.3	WEST COAST CORROSION PROTECTION		
22.3.1	The tenderer has to ensure that the corrosion protective coating is of a type suitable for a South African coastal environment. i.e. Carbo-mastic spec or equivalent		
22.3.2	Paint coatings chosen shall have the same UV, abrasion and corrosion resistance as the following paint program or better :-		
a)	Abrasive Blast Cleaning. A Class 2½ "Near White Metal" blast cleanliness, metal preparation.		
b)	A proprietary brand two-pack epoxy zinc rich primer for cathodic resistance in harsh corrosive environments		
c)	A proprietary brand two-component high gloss acrylic polyurethane top coat		
d)	The paint offered shall have at least a 5 year corrosion protection following marine quality international standard i.e. Carbo-mastic spec or equivalent.		

NO (1)	DESCRIPTION (2) ITEM 3 – ADT WITH HOOKLIFT 25 TON	COMPLY? (3) YES / NO	BROCHURE (4) REFERENCE INFO
e)	The above paints are to be applied in accordance with the manufacturer's recommendations. The Contractor shall arrange for a suitable inspection authority to attend to each stage, approve and submit a report on the application		
23	MANUALS AND TRAINING		
23.1	Properly bound, original approved OEM operators, service and parts manuals in the English language must be provided on delivery.
23.2	a) Training for operators in the proper operation of the vehicle must be provided and included in the tendered price. b) Training for 4 candidates must be provided within two weeks of delivery of the vehicle or as and when required by the City of Cape Town
24	DELIVERY		
24.1	The vehicle shall be registered in the name of the City of Cape Town.
24.2	The cost of licensing, registration, number plates, etc. must be included in the price of the vehicle
24.3	The vehicle shall have permanent manufacturers plates whereupon relevant data is stamped i.e. the manufacturers name, model no, serial number, and year of manufacture. The plates are to be fixed as per OEM instructions.
24.4	The delivery cost must form part of the main item in the pricing schedule. The transportation of the vehicle must adhere to legal and safety regulations applicable.
24.5	Essential operator tools including wheel spanner and heavy duty hand held grease gun etc. to allow the operator to perform running maintenance is required.
24.6	State whether any free services are included in the tendered price and where such services will be carried out.
24.7	Pre- delivery service cost must be included in the tender price
24.8	Any unacceptable delays in delivery ensuing will attract prescribed penalties.

ADDENDUM 3.1

BASIC SKETCH OF THE VEHICLE REQUIRED

(Not to be construed as a representation of the actual vehicle required)

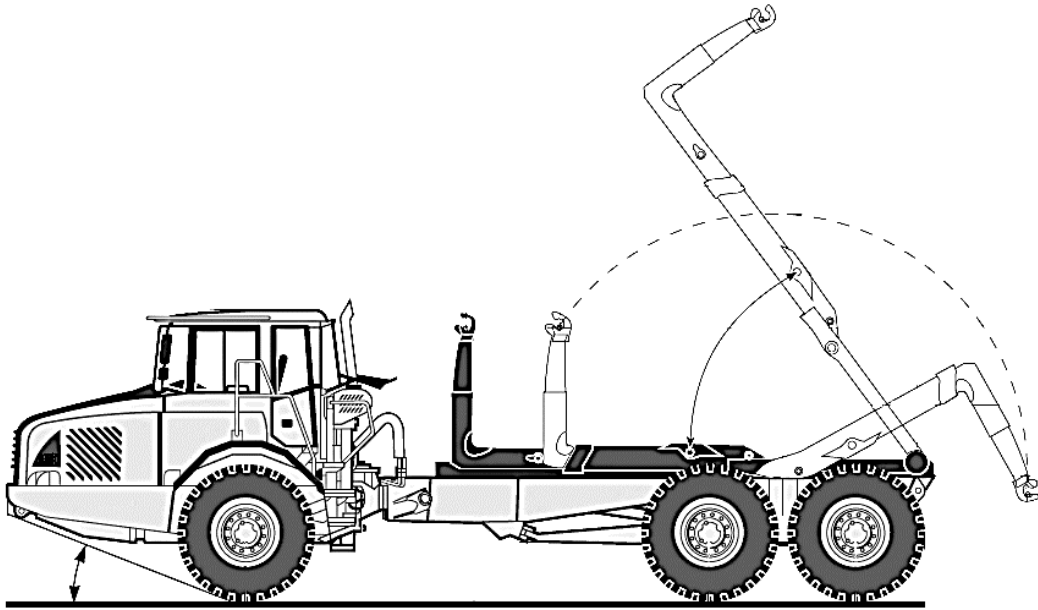

ADDENDUM 3.2

TYPICAL MAINTENANCE AND SERVICING SCHEDULES

The maintenance and service schedules **shall** include all the recommended OEM items for the particular item of plant under consideration. The tables below are not to be construed as complete lists but is merely an indication of the type of service required. The OEM maintenance and service book items shall at all times take preference and must be adhered to.

NO	DRIVELINE ITEM 3 – ADT AND HOOKLIFT 25 TON	Daily	100 hrs	250 hrs	500 hrs	1000 hrs	2000 hrs	3000 hrs	As Required
ENGINE									
1.	Adjust the valve clearance		X		X				
2.	Change the primary fuel filter		X			X			
3.	Change the secondary fuel filter					X			
4.	Change the oil and oil filters		X	X					
5.	Change the crankcase breather							X	
6.	Change the air cleaner secondary filter						X		
7.	Change the coolant						X		
8.	Check the oil level	X							
9.	Check the coolant level	X							
10.	Check the coolant specification								X
11.	Check drive belts tension			X					
12.	Check engine compartment components								X
13.	Check air cleaner primary filter								X
14.	Clean pre cleaner assembly								X
15.	Drain the primary fuel filter								X
16.	Flush and renew the coolant						X		
17.	Service injectors							X	
GEARBOX									
1.	Change filters					X			
2.	Change oil					X			
3.	Check oil level	X							
HYDRAULICS									
1.	Change oil						X		
2.	Change filters		X					X	
3.	Check breather filter					X			
4.	Check oil level	X							
CHASSIS AND AXLES									
1.	Change oil in differentials and final drives		X				X		
2.	Check oil level in differentials/final drives			X					
3.	Check service brake pads				X				
4.	Check park brake pads				X				

NO	DRIVELINE ITEM 3 – ADT AND HOOKLIFT 25 TON	Daily	100 hrs	250 hrs	500 hrs	1000 hrs	2000 hrs	3000 hrs	As Required
5.	Check wheel nuts								
CAB, PNEUMATICS AND ELECTRICAL									
1.	Change the air drier filter					X			
2.	Check operator controls and instruments	X							
3.	Check working lights, reverse buzzer, horn	X							
4.	Check electrical connections			X					
LUBRICATION									
1.	Grease hinges					X			
2.	Grease prop shafts						X		
3.	Grease the through drive bearing					X			
4.	Grease the PTO prop shaft					X			
5.	Grease lubrication points	X							

NO	CONTAINER SUBFRAME ITEM 3 – ADT AND HOOKLIFT 25 TON	WEEKLY 150 hrs	BI WEEKLY 250 hrs	MONTHLY 500 hrs	QUARTERLY 1000 hrs	BI ANNUAL 2500 hrs	ANNUAL 5000 hrs
SUBFRAME							
1.	Check sub frame for damaged components. Evidence of severe corrosion.			X			X
2.	Check for any weld cracking.			X			
TWISTLOCKS							
1.	Check for cracks and/or deformation on housing and locking device						X
2.	Malfunction of locking device (not rotating properly). Loose screws, springs damaged.						X
3.	Damaged or missing components.						X
4.	Evidence of severe corrosion						X
CONTAINER TIPPER HYDRAULICS							
1.	Check hydraulic fluid levels and colour as an indication of cleanliness.			X			
2.	Check all hydraulic filters for contamination.				X		
3.	Inspect hydraulic rams / rods for signs of stress and wear and corrosion.				X		
4.	Inspect system component seals and fluid lines for leaks.				X		
5.	Check supply hoses and shutoff valve for security condition and evidence of suction leaks.				X		
6.	Inspect hydraulic cylinder tubes for signs of ballooning. Perform a piston seal by pass test.				X		

NO	CONTAINER SUBFRAME ITEM 3 – ADT AND HOOKLIFT 25 TON	WEEKLY 150 hrs	BI WEEKLY 250 hrs	MONTHLY 500 hrs	QUARTERLY 1000 hrs	BI ANNUAL 2500 hrs	ANNUAL 5000 hrs
7.	Check all ram support brackets, ball joints, clevises, rod eyes and other connections for distortion or wear.						

HOOKLIFT

Periodic inspection should occur while the hook lift is in use. For the duration of the usage, inspect the hook lift for all of the following:

1.	Check hydraulic oil level.	X					
2.	Check all pins, bushings, shafts and gears for wear, cracks or distortion. Include all pivot points and bushings.						
3.	Check hydraulic systems for proper operating pressure.						
4.	Check and torque mainframe bolts.						
5.	Check cylinders for damaged rods, dented barrels, drift from oil leakage, leaks at rod seals or holding valves						
6.	Check PTO and hydraulic pumps for leaks.						
7.	Check hydraulic hose and tubing for evidence of damage such as blistering, crushing or abrasion.						
8.	Check frame bolt tightness - torque barrel nuts and mounting bolts during first month of operation and quarterly thereafter.						
9.	Check lubrication and apply lube where needed.						
10.	Check structural weldments for bends, cracks or breaks.						
11.	Check all control, safety and capacity placards for readability and secure attachment.						
12.	Inspect all electrical wires and connections or deteriorated insulation and bare wire. Replace as needed.						

ITEM 4 – 18 TON FRONT END WHEELED LOADER

LOADER OEM	
LOADER MODEL	
COUNTRY OF ORIGIN	

NO	(1)	DESCRIPTION	(2)	COMPLY? (3)	BROCHURE	(4)
		ITEM 4 – 18 TON FRONT END WHEELED LOADER		YES / NO	REFERENCE INFO	
1		SPECIFICATION SUMMARY				
1.1		A heavy duty front end, wheeled loader in 4x4 axle configuration with an operating weight of not less than 18 000 kg is required.		
1.2		The loaders will be used at the City of Cape Town’s landfill sites.		
1.3		The loaders offered must be a proven robust proprietary brand, of the latest design and material construction for operation off the highway on uneven, rough terrain.		
1.4		Clearly <u>highlighted</u> original OEM brochures describing in detail the front end loaders must be submitted with tender submission or as and when required by the City of Cape Town’s technical evaluation team.		
1.5		The entire tender document must be scanned in searchable PDF format and submitted on a flash drive along with the tender document. Scanning in jpg format is not acceptable.		
2		TENDERERS GUIDE				
2.1		The tenderer is to carefully scrutinize each clause and fill in the document as follows:-		
2.2		Full compliance to the requirement of the technical specification clause must be indicated by the word “Yes” or “No” in column 3.		
2.3		If a required item is standard fitment, then the word “Standard” may be written in column 4 in addition to the “Yes” in column 3.		
2.4		In the case of “No” being entered the tenderer may offer an explanation in the column 4.		
2.5		Where specific data is required, this may be cross referenced in column 4 to an OEM brochure page number and then the respective clauses highlighted / underlined in such named brochures for ease of evaluation.		
3		MAINTENANCE AND SERVICING FACILITIES				

NO (1)	DESCRIPTION (2) ITEM 4 – 18 TON FRONT END WHEELED LOADER	COMPLY? (3) YES / NO	BROCHURE (4) REFERENCE INFO
3.1	The tenderer must either have or have access to, accredited and fully equipped facilities within the boundaries of City of Cape Town area which are OEM approved for the maintenance, repairs including structural, hydraulic, diagnostics and major component overhauls of the front end loaders offered.
3.2	FRONT END LOADER		
3.2.1	Maintenance Facility Address GPS Co-ordinates	S° '" E° '"
3.2.2	a) Tenderers must provide either a letter from the OEM or a copy of the Service Level Agreement (SLA) with their service provider indicating that: - b) the facilities offered are OEM approved for the maintenance, repair, hydraulic, diagnostic testing and major overhauls of the front end wheeled loaders offered while under warranty. c) Tenderers who do not to have access to established OEM accredited facilities must refer to 36.1 of the Special Conditions of Contract for guidance if they wish to participate in this tender. d) In this context the tenderer is pay attention to the requirements of the Condition of Tender clauses 2.2.1.1.8. to 2.2.1.1.11
4	DEFINITIONS		
4.1	The front end loaders will be referred to as the “vehicle” in the technical specification.
5	APPLICABLE STANDARDS		
	The vehicle must conform to the following standards:-		
5.1	SANS 1517:2005: - Lubricating oil diesel engines
5.2	SANS 10281:2003 - Sound levels
5.3	SANS 20049:2009 - Particulate pollutants engines (ECE R49.02B)
5.4	SANS 10168:2002 - Restraining devices (safety belts) in vehicles
5.5	SANS 12944-4:2023 - Paints and varnishes – Corrosion protection of steel structures by protective paint systems – Part 4: Types of surface and surface preparation

NO (1)	DESCRIPTION (2) ITEM 4 – 18 TON FRONT END WHEELED LOADER	COMPLY? (3) YES / NO	BROCHURE (4) REFERENCE INFO
5.6	SANS 12944-5:2023 - Paints and varnishes – Corrosion protection of steel structures by protective paint systems – Part 5: Protective paint systems.
5.7	SANS 12944-7:2023 - Paints and varnishes – Corrosion protection of steel structures by protective paint systems – Part 7: Execution and supervision of paint work. D
5.8	ISO 9533: - Audible warning systems
5.9	IEC 60529 IP66 - Ingress protection rating – water and dust
5.10	ISO 3471:2008 - Earth-moving machinery - Roll-over protective structures
5.11	ISO 3449:2005:- Earth-moving machinery - Falling-object protective structures
5.12	ISO 3471, SAE J1040 / ISO 3449, SAE J231 :- ROPS / FOPS
5.13	Addendum 13B : General Technical Specifications
6	CHASSIS		
6.1	The chassis is to be constructed from high-strength, welded-alloy steel and all articulation joints reinforced according to OEM standards.
6.2	The machine shall have an articulated chassis with full hydraulic power steering.
6.3	The vehicle must be fitted with under-side protection guards (6mm minimum thickness mild steel plate) under the engine and transmission compartments, as well as driveline protection
6.4	The chassis is to incorporate a centralised easily accessible lubrication bank for ease of greasing remote and hard to reach points.
6.5	The tenderer is to offer an auto lubrication system for greasing such remote points.
6.6	The diesel tank must be positioned for maximum ground clearance
6.7	All fuel tank caps and battery boxes must be lockable
6.8	See Addendum 4.1 for a basic layout of the vehicle.
7	ENGINE		
7.1	The front end loader must be equipped with a turbocharged common rail diesel engine delivering a maximum net output of not less than 170 kW and maximum net torque of not less than 1000 Nm measured		

NO (1)	DESCRIPTION (2) ITEM 4 – 18 TON FRONT END WHEELED LOADER	COMPLY? (3) YES / NO	BROCHURE (4) REFERENCE INFO
	to SANS 10013-1: 2006 standards.
7.2	Make and model Capacity Maximum Output (Kw @ rpm) @ Sea level Maximum Torque (Nm @ rpm) @ Sea levelcc ³kWrpmNmrpm
7.3	The vehicle emissions under start up and operating conditions shall comply with the International Euro 2 standard as a minimum. Euro Standard
7.4	Engine performance curves must be shown in technical brochures.
7.5	The engine is required to operate on proprietary brand lubricating oil to the current applicable standards and in use in the heavy vehicle industry in South Africa.
7.6	The engine oil dipstick, fill point, oil and fuel and any particulate filters, and coolant reservoir are to be readily accessible for ease of maintenance.
7.7	The air cleaner fitted must be of the two-stage dry type, incorporating automatic intermittent self-cleaning action and preferably be of South African manufacture.
7.8	The engine and gearbox oil drains must be in easily accessible positions to facilitate emptying without the risk of polluting the environment.
7.9	ENGINE PROTECTION UNIT (E.P.U.)		
7.9.1	The vehicle shall incorporate a fail-safe mechanical engine monitoring system which monitors: - - oil pressure; - water temperature; - water level; - engine speed
7.9.2	In the event of a fault condition the EPU shall immediately cut out the engine or decrease engine revs to idle and keep the engine in this state until the fault condition is attended to.
7.9.3	The service plan is to include the necessary periodic inspection and servicing of all sensors according to OEM requirements
7.10	TURBO PROTECTION SYSTEM		
7.10.1	A proprietary protection system shall be fitted to prevent damage to the turbo charger in the event the engine is switched off prematurely, "Turboprotect" or equivalent.
8	RADIATOR		
8.1	The radiator shall be equipped with cooling fins spaced at an optimum OEM pitch, able to cool at an ambient		

NO (1)	DESCRIPTION (2) ITEM 4 – 18 TON FRONT END WHEELED LOADER	COMPLY? (3) YES / NO	BROCHURE (4) REFERENCE INFO
	temperature of up to 40 deg C.
8.2	The radiator is to be protected by a proprietary brand pre filter screen fitted in a radiator guard panel to protect the fins from being clogged by fine particles / dust such as is found at a landfill site.
8.3	Airflow through the pre-filter must be at the correct OEM prescribed level for proper radiator cooling.
8.4	The radiator guard panel is to be easily removed for purposes of cleaning.
8.5	A reversing fan (or reversible fan) is to incorporated for periodic purging of debris.
8.6	Coolant drains must be placed in an easy to reach position to facilitate emptying without the risk of polluting the environment.
9	TRANSMISSION		
9.1	The vehicle may be powered by: - a) A complete hydrostatic drive transmission or b) A fully automatic power-shift transmission and matched torque converter c) A fully automatic transmission with matched torque converter d) Transmission control modules / shift inhibitor to prevent driveline shock loading must be incorporated where necessary.
9.2	Rear axles are to be designed for maintenance free components i.e. with sealed maintenance free bearings and bushings.
9.3	In all cases, an oil sample must be taken and sent to a local laboratory WearCheck or equivalent for a baseline gearbox oil cleanliness report.
9.4	Engine and transmission diagnostics must be possible via connection to a laptop from the vehicles diagnostic port.
10	BRAKES		
10.1	Full details of service brakes, parking brakes, auxiliary brakes and any independent emergency parking brake must be submitted in brochures.
11	STEERING		

NO (1)	DESCRIPTION (2) ITEM 4 – 18 TON FRONT END WHEELED LOADER	COMPLY? (3) YES / NO	BROCHURE (4) REFERENCE INFO
11.1	The steering system is to comprise double acting cylinders, with an integrated emergency steering pump (hydraulic or electro/hydraulic) in the event of engine cut out or main hydraulic circuit failure.
11.2	Articulation angle in each direction shall be at least 37 deg degrees
12	WHEELS AND TYRES		
12.1	a) The vehicle must be fitted with suitably sized OTR steel radial tyres, preferably of South African manufacture no smaller than 23.5 R 25 and suitably rated for duty on rough terrain such as is found on land fill sites. b) The size and ratings must be freely available within the geographical boundaries of the City of Cape Town.
13	ELECTRICAL SYSTEM		
13.1	The electrical system shall be 24V with deep cycle heavy duty batteries fitted, AGM (Absorption Glass Mat) type or equivalent.
13.2	The alternator must not be rated less than 50 Amp
13.3	The battery compartment must be lockable and tamper proof.
13.4	All electrical wiring connectors must be automotive double-seal type, with wiring in split convoluted looms.
13.5	An audible reverse warning beeper with an audio output of not less than 90 dB measured at 1 meter be fitted if not supplied as standard fitment.
13.6	An anti-theft system, Vesa approved, must be fitted to prevent unauthorized engine starting.
13.7	A master disconnect switch must be available at ground switch.
13.8	LIGHTING		
13.8.1	Please refer to Addendum 13 B clause 13.8 for clarity on LED light fitment. This will apply to any LED lighting supplied as standard on the vehicle.
13.8.2	The vehicle shall be fitted with a Class 1 Gen 3 LED type amber hazard light on the truck cab.
13.8.3	Class 1 Gen 111 (or better) LED type work lights, rated at least 20W output, shall be mounted on the front of the cab facing forward and on either side of the cab facing outwards

NO (1)	DESCRIPTION (2) ITEM 4 – 18 TON FRONT END WHEELED LOADER	COMPLY? (3) YES / NO	BROCHURE (4) REFERENCE INFO
14	CAB		
14.1	The cab shall be weatherproof, lockable, with tinted safety glass windows which shall allow an unobstructed view of all operations.
14.2	The cab shall be ROPS (roll over protection) and FOPS (falling object) protected and shall be installed on anti-vibration mounts onto the chassis.
14.3	The vehicle suspension type must be selected to minimise vibration transmitted to the cab.
14.4	Noise level measured at the driver's ear shall be less than 80 Db(A)
14.5	The operator's seat shall be a heated, air suspension type and be adjustable for rake, position and the mass of the operator, and shall be cushioned and upholstered in durable material. Padded armrests shall be fitted
14.6	Driver seatbelt and passenger seatbelt (if applicable) shall be fitted
14.7	Adequate front and rear wipers and washers shall be fitted
14.8	A proprietary brand AM / FM radio with auxiliary and USB inputs as well as blue tooth functionality, shall be fitted in the event that the vehicle is not supplied with one as a standard fitment.
14.9	The cab shall be fitted with a proprietary brand HVAC climate control system if not a standard fitment.
14.10	The cab shall be fitted with a high efficiency particulate air (HEPA) filter system designed to trap microscopic pollutants including pollen, mould and common allergens
14.11	If an hour meter is not offered as standard, then: - a) A non-tamper proof digital hour meter (Hella or equivalent) logging engine hours must be mounted in a convenient and easily visible position on dashboard b) The instrument must have a metering capacity of 9999 hrs with a digital readout of 1/10 th of an hour. c) The meter must be connected to the alternator circuit.
14.12	A proprietary brand reversing camera system with colour LCD monitor shall be installed in the cab "LiftCam HD" or equivalent is to be installed.
14.13			

NO (1)	DESCRIPTION (2) ITEM 4 – 18 TON FRONT END WHEELED LOADER	COMPLY? (3) YES / NO	BROCHURE (4) REFERENCE INFO
15	HYDRAULIC SYSTEM		
15.1	The hydraulic system is to accommodate a full load sensing system feeding the internal hydraulic functions.
15.2	A ground-driven, load sensing emergency steering pump is to be integrated into the main hydraulic system.
15.3	OIL CLEANLINESS		
15.3.1	The hydraulic reservoirs must be filled oil to a classification ISO-L-HV in accordance ISO 6743 - 4, viscosity grade 46 hydraulic oil at a VI of at least 140. Shell Tellus S2 V46 or equivalent.
15.3.2	The cleanliness standards as set out in ISO 4406 and must be equal to or better than 18/16/14
15.3.3	Under no circumstances must “new” oil be decanted directly from drums into reservoirs without first going through an oil polishing unit to obtain the required cleanliness level.
15.3.4	The hydraulic oil tank shall incorporate easily accessible and replaceable spin on filters.
15.3.5	Hydraulic pressure check points are to be grouped together in an easily accessible position with standard hydraulic connection points where possible.
16	LUBRICATION		
16.1	Greasing lubrication ports must be located on the outside of the machine where practical without the need for crawling under the machine or into awkward unsafe positions.
17	BUCKET		
17.1	The loader bucket linkages shall be designed for high breakout force and fast dump action, with fully supported and sealed pins in hinge points
17.2	The unit shall be fitted with a standard general purpose bucket, having a struck capacity of at least 3.0 cubic metres and should be able to be fitted with optional bolt-on “ground engaging tools” and with bolt on cutting edge ground engaging tools
17.3	The bucket is to be of sturdy construction with material such as Hardox 450 or equivalent, being used in the high wear areas.
17.4	The static straight tipping load shall be at least 12 000 kg
17.5	The breakout force capability shall be at least 120 kN

NO (1)	DESCRIPTION (2) ITEM 4 – 18 TON FRONT END WHEELED LOADER	COMPLY? (3) YES / NO	BROCHURE (4) REFERENCE INFO
17.6	The maximum dump height shall be no less than 2700 mm at a dump angle of at least 45 deg.
17.7	The unit shall be fitted with a standard general purpose bucket, having a struck capacity of at least 3.0 cubic metres and should be fitted with bolt on cutting edge ground engaging tools		
18	CYCLE TIME		
18.1	The total cycle time i.e. for power lift, tilt, lower empty shall not be greater than 11 seconds
19	SPARES HOLDING		
	<p>a) The tenderer shall guarantee here the availability of a full range of spare parts (running and critical), ex stock for the vehicle within the geographical boundaries of the City of Cape Town.</p> <p>b) Any limitation to the availability shall be explained in a covering letter attached to the tender documents.</p>	<p>.....</p> <p>.....</p>	<p>.....</p> <p>.....</p>
19.1	FRONT END LOADER		
19.1.1	<p>Tenderers shall state the location of spare parts.</p> <p style="text-align: center;">Running spares (Same day)</p> <p style="text-align: center;">Mechanical / driveline spares</p> <p style="text-align: center;">Body components (interior / exterior)</p>	<p>.....</p> <p>.....</p> <p>.....</p>	LOCATION
20	CORROSION PROTECTION		
20.1	The tenderer has to ensure that the protective coating is of a type suitable for a South African coastal environment.
20.2	Paint coatings chosen shall have the same UV, abrasion and corrosion resistance as the following paint program or better :-
20.2.1	Abrasive Blast Cleaning. A Class 2½ "Near White Metal" blast cleanliness, metal preparation.
20.2.2	A proprietary brand two-pack epoxy zinc rich primer for cathodic resistance in harsh corrosive environments
20.2.3	A proprietary brand two-component high gloss acrylic polyurethane top coat
21	WARRANTY		
21.1	VEHICLE		

NO (1)	DESCRIPTION (2) ITEM 4 – 18 TON FRONT END WHEELED LOADER	COMPLY? (3) YES / NO	BROCHURE (4) REFERENCE INFO
21.1.1	The complete vehicle must be electrically, mechanically and structurally guaranteed for at least 5 years
22	SERVICE PLAN		
22.1	SERVICE PLAN		
22.1.1	A service plan covering the complete vehicle and fitted accessories for the full warranty period of 5 year or 4000 hr must be offered.
22.1.2	a) Full details of such service plans must be supplied with the tender document or as and when required by the City of Cape Town. b) See Addendum 4.2 for typical service schedules for the vehicle.
23	OPTIONAL EXTRAS		
23.1	AUTO LUBE SYSTEM		
23.1.1	If not standard with offer, the tenderer is to offer an auto lubrication system for greasing such remote points as an optional extra.
23.2	FIRE SUPPRESSION SYSTEM		
23.2.1	The tenderer is to offer a proprietary brand dual agent - DCP and aqueous film forming foam liquid fire suppressant system (Ansulite or similar) as an optional extra. The specified fire suppression system shall incorporate:-
23.2.2	a) Sufficient and appropriately placed fire-detecting sensing manifold pipes.
	b) A control panel in the cab to detect a fire and alert the operator
	c) Actuators to discharge suppressant automatically and manually
	d) Tanks filled with fire suppressant DCP and aqueous film forming foam (Ansulite or similar)
	e) Distribution network of tubes, hoses, and nozzles
23.2.3	It is essential that fitment of the fire suppression system be done by a registered qualified artisan / technician in terms of South African legislation set out in this regard.
23.2.4	The fire suppression system shall carry a 3 year warranty from the date of handover.
23.2.5	The City of Cape Town reserves the right to view the		

NO (1)	DESCRIPTION (2) ITEM 4 – 18 TON FRONT END WHEELED LOADER	COMPLY? (3) YES / NO	BROCHURE (4) REFERENCE INFO
	tenderers compliance in this regard as and when it deems it fit to do so.
23.3	WEST COAST CORROSION PROTECTION		
23.3.1	The tenderer has to ensure that the corrosion protective coating is of a type suitable for a South African coastal environment. i.e. Carbo-mastic spec or equivalent		
23.3.2	Paint coatings chosen shall have the same UV, abrasion and corrosion resistance as the following paint program or better :-		
a)	Abrasive Blast Cleaning. A Class 2½ “Near White Metal” blast cleanliness, metal preparation.		
b)	A proprietary brand two-pack epoxy zinc rich primer for cathodic resistance in harsh corrosive environments		
c)	A proprietary brand two-component high gloss acrylic polyurethane top coat		
d)	The paint offered shall have at least a 5 year corrosion protection following marine quality international standard i.e. Carbo-mastic spec or equivalent.		
e)	The above paints are to be applied in accordance with the manufacturer's recommendations. The Contractor shall arrange for a suitable inspection authority to attend to each stage, approve and submit a report on the application		
24	MANUALS AND TRAINING		
24.1	Properly bound, original approved OEM operators, service and parts manuals in the English language must be provided on delivery.
24.2	a) Training for operators in the proper operation of the vehicle must be provided and included in the tendered price. b) Training for 4 candidates must be provided within two weeks of delivery of the vehicle or as and when required by the City of Cape Town
25	DELIVERY		
25.1	The vehicle shall be registered in the name of the City of Cape Town.
25.2	The cost of licensing, registration, number plates, etc. must be included in the price of the vehicle
25.3	The vehicle shall have permanent manufacturers plates whereupon relevant data is stamped i.e. the manufacturers name, model no, serial number, and year		

NO (1)	DESCRIPTION (2) ITEM 4 – 18 TON FRONT END WHEELED LOADER	COMPLY? (3) YES / NO	BROCHURE (4) REFERENCE INFO
	of manufacture. The plates are to be fixed as per OEM instructions.
25.4	The delivery cost must form part of the main item in the pricing schedule. The transportation of the vehicle must adhere to legal and safety regulations applicable.
25.5	Essential operator tools including wheel spanner and heavy duty hand held grease gun etc. to allow the operator to perform running maintenance is required.
25.6	State whether any free services are included in the tendered price and where such services will be carried out.
25.7	Pre- delivery service cost must be included in the tender price
25.8	Any unacceptable delays in delivery ensuing will attract prescribed penalties.

ADDENDUM 4.1

BASIC SKETCH OF THE VEHICLE REQUIRED

(Not to be construed as a representation of the actual vehicle required)

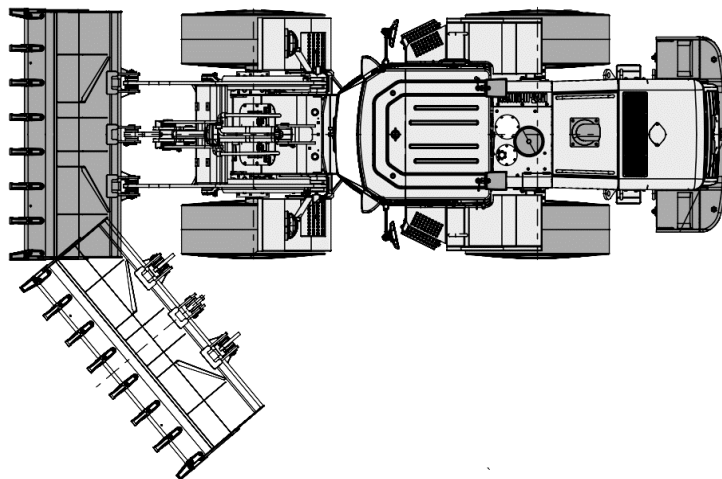
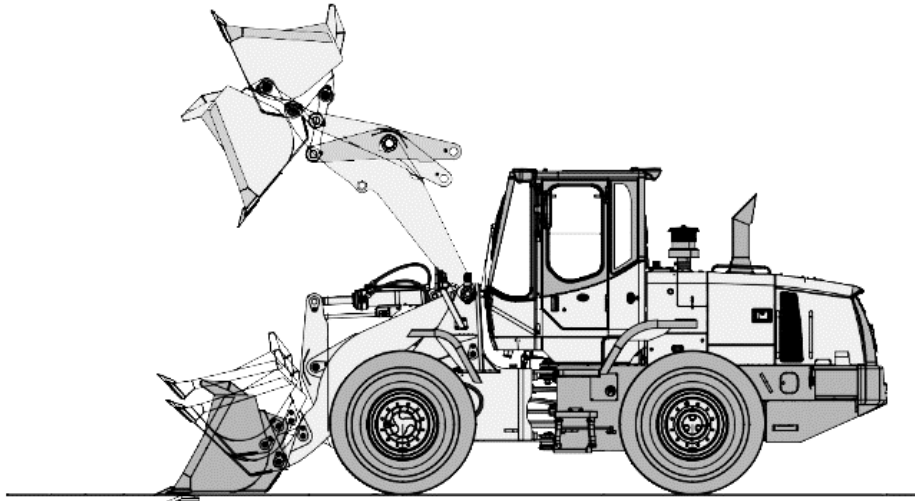

ADDENDUM 4.2

TYPICAL MAINTENANCE AND SERVICING SCHEDULES

The maintenance and service schedules **shall** include all the recommended OEM items for the particular item of plant under consideration. The tables below are not to be construed as complete lists but is merely an indication of the type of service required. The OEM maintenance and service book items shall at all times take preference and must be adhered to.

NO	DRIVELINE ITEM 4 – WHEELED LOADER 18 TON	Daily	100 hrs	250 hrs	500 hrs	1000 hrs	2000 hrs	3000 hrs	As Required
ENGINE									
1.	Adjust the valve clearance		X		X				
2.	Change the primary fuel filter		X			X			
3.	Change the secondary fuel filter					X			
4.	Change the oil and oil filters		X	X					
5.	Change the crankcase breather							X	
6.	Change the air cleaner secondary filter						X		
7.	Change the coolant						X		
8.	Check the oil level	X							
9.	Check the coolant level	X							
10.	Check the coolant specification								X
11.	Check drive belts tension			X					
12.	Check engine compartment components								X
13.	Check air cleaner primary filter								X
14.	Clean pre cleaner assembly								X
15.	Drain the primary fuel filter								X
16.	Flush and renew the coolant						X		
17.	Service injectors							X	
GEARBOX									
1.	Change filters					X			
2.	Change oil					X			
3.	Check oil level	X							
HYDRAULICS									
1.	Change oil						X		
2.	Change filters		X					X	
3.	Check breather filter					X			
4.	Check oil level	X							
CHASSIS AND AXLES									
1.	Change oil in differentials and final drives		X				X		
2.	Check oil level in differentials/final drives			X					
3.	Check service brake pads				X				

NO	DRIVELINE ITEM 4 – WHEELED LOADER 18 TON	Daily	100 hrs	250 hrs	500 hrs	1000 hrs	2000 hrs	3000 hrs	As Required
4.	Check park brake pads				X				
5.	Check wheel nuts								
CAB, PNEUMATICS AND ELECTRICAL									
1.	Change the air drier filter					X			
2.	Check operator controls and instruments	X							
3.	Check working lights, reverse buzzer, horn	X							
4.	Check electrical connections			X					
LUBRICATION									
1.	Grease hinges					X			
2.	Grease prop shafts						X		
3.	Grease the through drive bearing					X			
4.	Grease the PTO prop shaft					X			
5.	Grease lubrication points	X							

ITEM 5 – LANDFILL COMPACTOR 40 TON

COMPACTOR OEM			
COMPACTOR MODEL			
COUNTRY OF ORIGIN			

NO	(1)	DESCRIPTION	(2)	COMPLY? (3)	BROCHURE	(4)
		ITEM 5 – LANDFILL COMPACTOR 40 TON		YES / NO	REFERENCE INFO	
1		SPECIFICATION SUMMARY				
1.1		A heavy duty landfill compactor of overall mass not less than 35 000 kg is required for operation on the City of Cape Town’s landfill sites.		
1.2		The compactors offered must be a proven robust proprietary brand, of the latest design and material construction for operation off the highway on uneven, rough terrain.		
1.3		Clearly <u>highlighted</u> original OEM brochures describing in detail the landfill compactors must be submitted with tender submission or as and when required by the City of Cape Town’s technical evaluation team.		
1.4		The entire tender document must be scanned in searchable PDF format and submitted on a flash drive along with the tender document. Scanning in jpg format is not acceptable.		
2		TENDERERS GUIDE				
2.1		The tenderer is to carefully scrutinize each clause and fill in the document as follows:-		
2.2		Full compliance to the requirement of the technical specification clause must be indicated by the word “Yes” or “No” in column 3.		
2.3		If a required item is standard fitment, then the word “Standard” may be written in column 4 in addition to the “Yes” in column 3.		
2.4		In the case of “No” being entered the tenderer may offer an explanation in the column 4.		
2.5		Where specific data is required, this may be cross referenced in column 4 to an OEM brochure page number and then the respective clauses highlighted / underlined in such named brochures for ease of evaluation.		
3		MAINTENANCE AND SERVICING FACILITIES				

NO (1)	DESCRIPTION (2) ITEM 5 – LANDFILL COMPACTOR 40 TON	COMPLY? (3) YES / NO	BROCHURE (4) REFERENCE INFO
3.1	The tenderer must either have or have access to, accredited and fully equipped facilities within the boundaries of City of Cape Town area which are OEM approved for the maintenance, repairs including structural, hydraulic, diagnostics and major component overhauls of the landfill compactors offered.
3.2	LANDFILL COMPACTOR		
3.2.1	Maintenance Facility Address GPS Co-ordinates	S° '" E° '"
3.2.2	<p>a) Tenderers must provide either a letter from the OEM or a copy of the Service Level Agreement (SLA) with their service provider indicating that: -</p> <p>b) the facilities offered are OEM approved for the maintenance, repair, hydraulic, diagnostic testing and major overhauls of the landfill compactors offered while under warranty.</p> <p>c) Tenderers who do not to have access to established OEM accredited facilities must refer to 36.1 of the Special Conditions of Contract for guidance if they wish to participate in this tender.</p> <p>d) In this context the tenderer is pay attention to the requirements of the Condition of Tender clauses 2.2.1.1.8. to 2.2.1.1.11</p>
4	DEFINITIONS		
4.1	The landfill compactors will be referred to as the “vehicle” in the technical specification.
5	APPLICABLE STANDARDS		
	The vehicle must conform to the following standards		
5.1	SANS 1517:2005: - Lubricating oil diesel engines
5.2	SANS 10281:2003 - Sound levels
5.3	SANS 20049:2009 - Particulate pollutants engines (ECE R49.02B)
5.4	SANS 10168:2002 - Restraining devices (safety belts) in vehicles
5.5	SANS 12944-4:2023 - Paints and varnishes – Corrosion protection of steel structures by protective paint systems – Part 4: Types of surface and surface preparation
5.6	SANS 12944-5:2023 - Paints and varnishes – Corrosion protection of steel structures by protective paint systems		

NO (1)	DESCRIPTION (2) ITEM 5 – LANDFILL COMPACTOR 40 TON	COMPLY? (3) YES / NO	BROCHURE (4) REFERENCE INFO
	– Part 5: Protective paint systems.
5.7	SANS 12944-7:2023 - Paints and varnishes – Corrosion protection of steel structures by protective paint systems – Part 7: Execution and supervision of paint work. D
5.8	ISO 9533: - Audible warning systems
5.9	IEC 60529 IP66 - Ingress protection rating – water and dust
5.10	ISO 3471:2008 - Earth-moving machinery - Roll-over protective structures
5.11	ISO 3449:2005:- Earth-moving machinery - Falling-object protective structures
5.12	ISO 3471, SAE J1040 / ISO 3449, SAE J231: - ROPS / FOPS
5.13	ISO 9246 Capacity Rating Dozer Blades.
5.14	Addendum 13B : General Technical Specifications
6	CHASSIS		
6.1	The chassis is to be constructed from high-strength, welded-alloy steel to OEM standards.
6.2	The machine must incorporate extensive sensitive area guarding i.e. typically <ul style="list-style-type: none"> a) engine and power-train guards b) front-frame guards c) axle-wrapping and seal guards d) fine-mesh air-inlet screen e) under-hood ventilation system f) swing down belly pans, g) a radiator grill guard h) striker bars / cleaner fingers i) or any other equivalent guarding methods.
6.3	Maintenance free trunnion bearings must be incorporated in the design.
6.4	The diesel tank must be positioned for maximum ground clearance
6.5	All fuel tank caps and battery boxes must be lockable
6.6	See Addendum 5.1 for a basic layout of the vehicle.
6.7	Trash guard must be fitted on top edge of the bucket		
7	ENGINE		
7.1	The compactor must be equipped with a turbocharged common rail diesel engine delivering a maximum net output of not less than 300 kW and maximum net torque		

NO (1)	DESCRIPTION (2) ITEM 5 – LANDFILL COMPACTOR 40 TON	COMPLY? (3) YES / NO	BROCHURE (4) REFERENCE INFO
	of not less than 2000 Nm measured to SANS 10013-1: 2006 standards.
7.2	Engine make and model Capacity Maximum Net Output (Kw @ rpm) @ Sea level Maximum Net Torque (Nm @ rpm) @ Sea levelcc ³kWrpmNmrpm
7.3	The vehicle emissions under start up and operating conditions shall comply with the International Euro 2 standard as a minimum. Euro Standard
7.4	Engine performance curves must be shown in technical brochures.
7.5	The engine is required to operate on proprietary brand lubricating oil to the current applicable standards and in use in the heavy vehicle industry in South Africa.
7.6	The engine oil dipstick, fill point, oil and fuel and any particulate filters, coolant or Adblue reservoirs are to be readily accessible for ease of maintenance.
7.7	The engine and gearbox oil drains must be in easily accessible positions to facilitate emptying without the risk of polluting the environment.
8	ENGINE PROTECTION UNIT (E.P.U.)		
8.1	The vehicle shall incorporate a fail-safe mechanical engine monitoring system which monitors: - - oil pressure; - water temperature; - water level; - engine speed
8.2	In the event of a fault condition the EPU shall immediately cut out the engine or decrease engine revs to idle and keep the engine in this state until the fault condition is attended to.
8.3	The service plan is to include the necessary periodic inspection and servicing of all sensors according to OEM requirements
9	TURBO PROTECTION SYSTEM		
9.1	A proprietary protection system shall be fitted to prevent damage to the turbo charger in the event the engine is switched off prematurely, "Turboprotect" or equivalent. If this is a standard fitment then the tenderer is to indicate as such.
9.2	In addition, the machine must have a delayed engine shutdown facility which shall turn the machine off once the turbo-charger has cooled down to the appropriate temperature.

NO (1)	DESCRIPTION (2) ITEM 5 – LANDFILL COMPACTOR 40 TON	COMPLY? (3) YES / NO	BROCHURE (4) REFERENCE INFO
10	RADIATOR		
10.1	The radiator shall be equipped with cooling fins spaced with a pitch of not less than 3mm and able to cool at an ambient temperature of up to 40 deg C.
10.2	The radiator is to be protected by a proprietary brand pre filter screen fitted in a radiator guard panel to protect the fins from being clogged by fine particles / dust such as is found at a landfill site.
10.3	Airflow through the pre-filter must be at the correct OEM prescribed level for proper radiator cooling.
10.4	The radiator guard panel is to be easily removed for purposes of cleaning.
10.5	A reversing fan (or reversible fan) is to incorporated for periodic purging of debris.
10.6	Coolant drains must be placed in an easy to reach position to facilitate emptying without the risk of polluting the environment.
11	TRANSMISSION		
11.1	The vehicle may be powered by: - a) A complete hydrostatic drive transmission or b) An automatic power-shift transmission and matched torque converter or c) Fully automatic transmission with matched torque converter d) Transmission control modules / shift inhibitor to prevent driveline shock loading must be incorporated where necessary.
11.2	For smooth gear shifting, a PWM controlled gearshift system (or equivalent) is to be incorporated. If equivalent systems are offered as standard, the tenderer is to indicate as such.
11.3	Engine and transmission diagnostics must be possible via connection to a laptop from the vehicles diagnostic port.
12	AXLES		
12.1	The machine shall be equipped with a fixed front axle and oscillating rear axle with fully floating axle shafts with planetary hub reductions.
12.2	Differential lock on the front axle with a limited slip rear axle.

NO (1)	DESCRIPTION (2) ITEM 5 – LANDFILL COMPACTOR 40 TON	COMPLY? (3) YES / NO	BROCHURE (4) REFERENCE INFO
13	BRAKES		
13.1	Full details of service brakes, parking brakes, auxiliary brakes and any independent emergency parking brake must be submitted in brochures.
14	STEERING		
14.1	The steering system is to comprise double acting cylinders and shall be load sensing and hydrostatically articulated. The steering articulation shall be at least ± 35 degrees. The oscillating angle shall be no less than 14 degrees.
15	COMPACTION WHEELS AND CLEATS		
15.1	Wheels shall be especially constructed from hard wearing steels specially designed for refuse compaction and clogging prevention.
15.2	The solid steel cleats shall have hard facing on all edges, and shall be effective for chopping and compacting refuse during travel in both directions.
15.3	Wheels with replaceable caps on the cleats are acceptable.
15.4	The front and rear wheels must be so designed to prevent any wire on the landfill site from wrapping around the axles and damaging the seals.
15.5	Striker bars must be incorporated covering the front and rear wheels.
16	ELECTRICAL SYSTEM		
16.1	The electrical system shall be 24 volt incorporating deep cycle, AGM (absorption glass mat) type batteries.
16.2	The alternator must not be rated less than 80 amp.
16.3	The battery compartment must be lockable and tamper proof.
16.4	All electrical wiring connectors must be automotive double-seal type, with wiring in split convoluted loom
16.5	An audible reverse warning beeper with an audio output of not less than 90 dB measured at 1 meter be fitted if not supplied as standard fitment.
16.6	An anti-theft system, Vesa approved, must be fitted to prevent unauthorized engine starting.
16.7	A master disconnect switch must be available at ground switch.
16.8	LIGHTING		

NO (1)	DESCRIPTION (2) ITEM 5 – LANDFILL COMPACTOR 40 TON	COMPLY? (3) YES / NO	BROCHURE (4) REFERENCE INFO
16.9	Please refer to Addendum 13 B clause 13.8 for clarity on LED light fitment. This will apply to any LED lighting supplied as standard on the vehicle.
16.10	The vehicle shall be fitted with a Class 1, Gen 111, LED type amber hazard light on the vehicle cab.
16.11	Class 1, Gen 111 (or better) LED type work lights, rated at least 20W output, shall be mounted on the front of the cab facing forward and on either side of the cab facing outwards
16.12	The access stairways must be illuminated with safety lighting Gen 111 LED or equivalent.
17	CAB		
17.1	The cab shall be weatherproof, lockable, with tinted safety glass windows which shall allow an unobstructed view of all operations.
17.2	The cab shall be ROPS (roll over protection) and FOPS (falling object) protected and shall be installed on anti-vibration mounts onto the chassis.
17.3	The vehicle suspension type must be selected to minimise vibration transmitted to the cab.
17.4	The operator sound pressure level according to ISO 6396:2008 must not be greater than 73 dB(A)
17.5	The operator's seat shall be a heated, air suspension type and be adjustable for rake, position and the mass of the operator, and shall be cushioned and upholstered in durable material. Padded armrests shall be fitted
17.6	Driver seatbelt and passenger seatbelt (if applicable) shall be fitted
17.7	Adequate front and rear wipers and washers shall be fitted
17.8	A proprietary brand AM / FM radio with auxiliary and USB inputs as well as blue tooth functionality, shall be fitted in the event that the vehicle is not supplied with one as a standard fitment.
17.9	The cab shall be fitted with a proprietary brand HVAC climate control system if not a standard fitment.
17.10	The cab shall be fitted with a high efficiency particulate air (HEPA) filter system designed to trap microscopic pollutants including pollen, mould and common allergens

NO (1)	DESCRIPTION (2) ITEM 5 – LANDFILL COMPACTOR 40 TON	COMPLY? (3) YES / NO	BROCHURE (4) REFERENCE INFO
17.11	<p>If an hour meter is not offered as standard, then: -</p> <p>a) A non-tamper proof digital hour meter (Hella or equivalent) logging engine hours must be mounted in a convenient and easily visible position on dashboard</p> <p>b) The instrument must have a metering capacity of 9999 hrs with a digital readout of 1/10th of an hour.</p> <p>c) The meter must be connected to the alternator circuit.</p>	<p>.....</p> <p>.....</p> <p>.....</p>	<p>.....</p> <p>.....</p> <p>.....</p>
17.12	A proprietary brand reversing camera system with colour LCD monitor shall be installed in the cab "LiftCam HD" or equivalent is to be installed.	<p>.....</p>	<p>.....</p>
18	HYDRAULIC SYSTEM		
18.1	The hydraulic system shall be powered by a variable displacement axial piston pump with a full load sensing system feeding the internal hydraulic functions.	<p>.....</p>	<p>.....</p>
18.2	If practical, a ground-driven, load sensing emergency steering pump is to be integrated into the main hydraulic system.	<p>.....</p>	<p>.....</p>
18.3	OIL CLEANLINESS		
18.3.1	The hydraulic reservoirs must be filled oil to a classification ISO-L-HV in accordance ISO 6743 - 4, viscosity grade 46 hydraulic oil at a VI of at least 140. Shell Tellus S2 V46 or equivalent.	<p>.....</p>	<p>.....</p>
18.3.2	The cleanliness standards as set out in ISO 4406 and must be equal to or better than 18/16/14.	<p>.....</p>	<p>.....</p>
18.3.3	Under no circumstances must "new" oil be decanted directly from drums into the vehicles reservoir without first going through an oil polishing unit to obtain the required cleanliness level.	<p>.....</p>	<p>.....</p>
18.3.4	The hydraulic oil tank shall incorporate easily accessible and utilise replaceable spin on filters.	<p>.....</p>	<p>.....</p>
18.3.5	Hydraulic pressure check points are to be grouped together in an easily accessible position with standard hydraulic connection points.	<p>.....</p>	<p>.....</p>
19	LUBRICATION		
19.1	The chassis is to incorporate a centralised easily accessible lubrication bank for ease of greasing remote and hard to reach points without the need for crawling under the machine or into awkward unsafe positions.	<p>.....</p>	<p>.....</p>

NO (1)	DESCRIPTION (2) ITEM 5 – LANDFILL COMPACTOR 40 TON	COMPLY? (3) YES / NO	BROCHURE (4) REFERENCE INFO
19.2	Routine checks from the ground level or machine platform are to be undertaken with the ease of operator access in mind.
19.3	Filters are to be grouped and accessed by removable side panels and a remote oil drain must be incorporated. The engine oil check and fill must be undertaken without needing to remove any panels.
20	BLADE		
20.1	The unit shall be fitted with a standard U shaped blade, having a capacity of at least 11 cubic metres.
20.2	The blade is to be of sturdy construction with material such as Hardox 450 or equivalent, being used in the high wear areas.
21	SPARES HOLDING		
21.1	<p>a) The tenderer shall guarantee here the availability of a full range of spare parts (running and critical), ex stock for the machine within the geographical boundaries of the City of Cape Town.</p> <p>b) Any limitation to the availability shall be explained in a covering letter attached to the tender documents.</p>	<p>.....</p> <p>.....</p>	<p>.....</p> <p>.....</p>
21.2	<p>Tenderers shall state the location of spare parts.</p> <p style="text-align: center;">Running spares (Same day)</p> <p style="text-align: center;">Mechanical / driveline spares</p> <p style="text-align: center;">Body components (interior / exterior)</p>	<p>.....</p> <p>.....</p> <p>.....</p>	LOCATION
22	CORROSION PROTECTION		
22.1	The tenderer has to ensure that the protective coating is of a type suitable for a South African coastal environment.
22.2	Paint coatings chosen shall have the same UV, abrasion and corrosion resistance as the following paint program or better :-
22.2.1	Abrasive Blast Cleaning. A Class 2½ “Near White Metal” blast cleanliness, metal preparation.
22.2.2	A proprietary brand two-pack epoxy zinc rich primer for cathodic resistance in harsh corrosive environments
22.2.3	A proprietary brand two-component high gloss acrylic polyurethane top coat
23	WARRANTY		
23.1	VEHICLE		

NO (1)	DESCRIPTION (2) ITEM 5 – LANDFILL COMPACTOR 40 TON	COMPLY? (3) YES / NO	BROCHURE (4) REFERENCE INFO
23.1.1	The complete vehicle must be electrically, mechanically and structurally guaranteed for at least 12 months or 2 000 hrs of operation.
23.2	CORROSION		
23.3	The complete vehicle shall have at least a 3 year corrosion protection warranty against body rust or paint defects, fair wear and tear excluded.
24	SERVICE PLAN		
24.1	SERVICE PLAN		
24.1.1	A service plan covering the full warranty period of 5 year.
24.1.2	a) Full details of such service plans must be supplied with the tender document or as and when required by the City of Cape Town.
25	OPTIONAL EXTRAS		
25.1	AUTO LUBE SYSTEM		
25.1.1	If not standard with offer, the tenderer is to offer an auto lubrication system for greasing such remote points as an optional extra.
26	FIRE SUPPRESSION SYSTEM		
26.1.1	The tenderer is to offer a proprietary brand dual agent - DCP and aqueous film forming foam liquid fire suppressant system (Ansulite or similar) as an optional extra. The specified fire suppression system shall incorporate:-
26.1.2	a) Sufficient and appropriately placed fire-detecting sensing manifold pipes.
	b) A control panel in the cab to detect a fire and alert the operator
	c) Actuators to discharge suppressant automatically and manually
	d) Tanks filled with fire suppressant DCP and aqueous film forming foam (Ansulite or similar)
	e) Distribution network of tubes, hoses, and nozzles
26.1.3	It is essential that fitment of the fire suppression system be done by a registered qualified artisan / technician in terms of South African legislation set out in this regard.
26.1.4	The fire suppression system shall carry a 3 year warranty from the date of handover.

NO (1)	DESCRIPTION (2) ITEM 5 – LANDFILL COMPACTOR 40 TON	COMPLY? (3) YES / NO	BROCHURE (4) REFERENCE INFO
26.1.5	The City of Cape Town reserves the right to view the tenderers compliance in this regard as and when it deems it fit to do so.
26.2	WEST COAST CORROSION PROTECTION		
26.2.1	The tenderer has to ensure that the corrosion protective coating is of a type suitable for a South African coastal environment. i.e. Carbo-mastic spec or equivalent		
26.2.2	Paint coatings chosen shall have the same UV, abrasion and corrosion resistance as the following paint program or better :-		
a)	Abrasive Blast Cleaning. A Class 2½ "Near White Metal" blast cleanliness, metal preparation.		
b)	A proprietary brand two-pack epoxy zinc rich primer for cathodic resistance in harsh corrosive environments		
c)	A proprietary brand two-component high gloss acrylic polyurethane top coat		
d)	The paint offered shall have at least a 5 year corrosion protection following marine quality international standard i.e. Carbo-mastic spec or equivalent.		
e)	The above paints are to be applied in accordance with the manufacturer's recommendations. The Contractor shall arrange for a suitable inspection authority to attend to each stage, approve and submit a report on the application		
27	MANUALS AND TRAINING		
27.1	Properly bound, original approved OEM operators, service and parts manuals in the English language must be provided on delivery.
27.2	<p>a) Training for operators in the proper operation of the vehicle must be provided and included in the tendered price.</p> <p>b) Training for 4 candidates must be provided within two weeks of delivery of the vehicle or as and when required by the City of Cape Town</p>
28	DELIVERY		
28.1	The vehicle shall be registered in the name of the City of Cape Town.
28.2	The cost of licensing, registration, number plates, etc. must be included in the price of the vehicle

NO (1)	DESCRIPTION (2) ITEM 5 – LANDFILL COMPACTOR 40 TON	COMPLY? (3) YES / NO	BROCHURE (4) REFERENCE INFO
28.3	The vehicle shall have permanent manufacturers plates whereupon relevant data is stamped i.e. the manufacturers name, model no, serial number, and year of manufacture. The plates are to be fixed as per OEM instructions.
28.4	The delivery cost must form part of the main item in the pricing schedule. The transportation of the vehicle must adhere to legal and safety regulations applicable.
28.5	Essential operator tools to allow the operator to perform running maintenance is required.
28.6	State whether any free services are included in the tendered price and where such services will be carried out.
28.7	Pre- delivery service cost must be included in the tender price
28.8	Any unacceptable delays in delivery ensuing will attract prescribed penalties.

ADDENDUM 5.1

The following image is just an illustration of the type of vehicle required i.e. a landfill compactor.

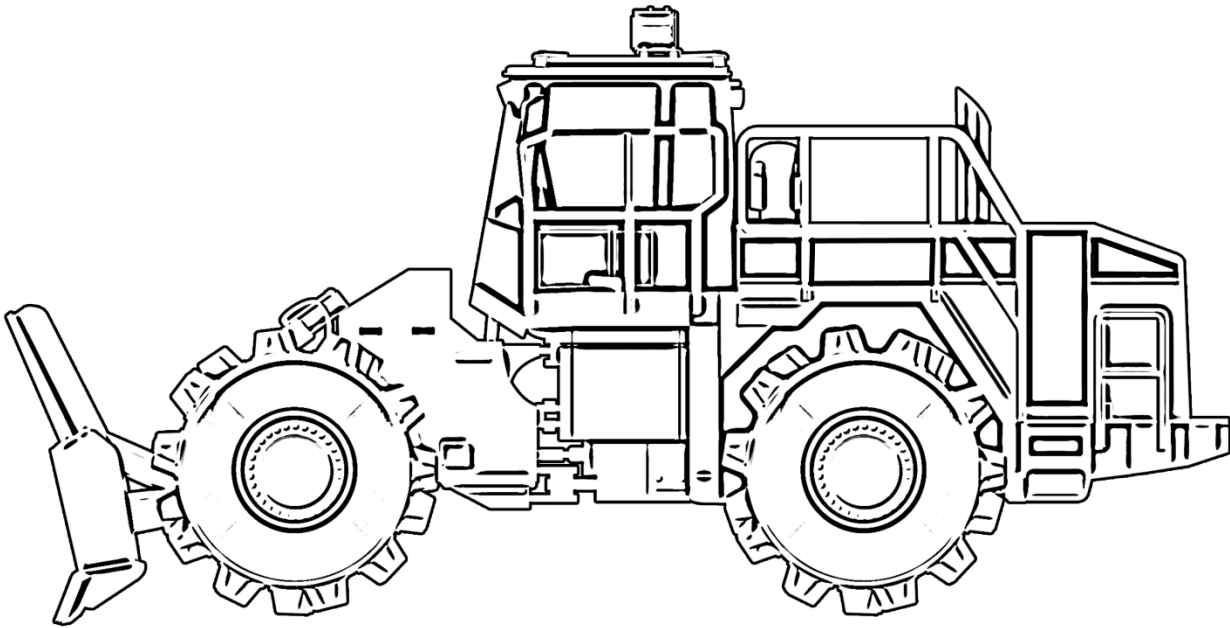

ITEM 6 – LANDFILL TRACK TYPE DOZER

COMPACTOR OEM			
COMPACTOR MODEL			
COUNTRY OF ORIGIN			

NO	(1)	DESCRIPTION ITEM 6 – TRACK TYPE DOZERS	(2)	COMPLY? (3) YES / NO	(4) BROCHURE REFERENCE INFO
1		SPECIFICATION SUMMARY			
1.1		A heavy duty track type dozer of overall mass not less than 20 000 kg is required for operation on the City of Cape Towns landfill sites.	
1.2		The track type dozers offered must be a proven robust proprietary brand, of the latest design and material construction for operation at a waste disposal landfill site.	
1.3		Clearly <u>highlighted</u> original OEM brochures describing in detail the dozers must be submitted with tender submission or as and when required by the City of Cape Town’s technical evaluation team.	
1.4		The entire tender document must be scanned in <u>searchable</u> PDF format and submitted on a flash drive along with the tender document. Scanning in jpg format is not acceptable.	
2		TENDERERS GUIDE			
2.1		The tenderer is to carefully scrutinize each clause and fill in the document as follows:-	
2.2		Full compliance to the requirement of the technical specification clause must be indicated by the word “Yes” or “No” in column 3.	
2.3		If a required item is standard fitment, then the word “Standard” may be written in column 4 in addition to the “Yes” in column 3.	
2.4		In the case of “No” being entered the tenderer may offer an explanation in the column 4.	
2.5		Where specific data is required, this may be cross referenced in column 4 to an OEM brochure page number and then the respective clauses highlighted / underlined in such named brochures for ease of evaluation.	
3		MAINTENANCE AND SERVICING FACILITIES			

NO (1)	DESCRIPTION (2) ITEM 6 – TRACK TYPE DOZERS	COMPLY? (3) YES / NO	BROCHURE (4) REFERENCE INFO
3.1	The tenderer must either have or have access to, accredited and fully equipped facilities within the boundaries of City of Cape Town area which are OEM approved for the maintenance, repairs including structural, hydraulic, diagnostics and major component overhauls of the landfill compactors offered.
3.2	TRACK TYPE DOZER		
3.2.1	Maintenance Facility Address GPS Co-ordinates	S° '" E° '"
3.2.2	<p>a) Tenderers must provide either a letter from the OEM or a copy of the Service Level Agreement (SLA) with their service provider indicating that: -</p> <p>b) the facilities offered are OEM approved for the maintenance, repair, hydraulic, diagnostic testing and major overhauls of the track type dozers offered while under warranty.</p> <p>c) Tenderers who do not to have access to established OEM accredited facilities must refer to 36.1 of the Special Conditions of Contract for guidance if they wish to participate in this tender.</p> <p>d) In this context the tenderer is pay attention to the requirements of the Condition of Tender clauses 2.2.1.1.8. to 2.2.1.1.11</p>
4	DEFINITIONS		
4.1	The track type dozers will be referred to as the “vehicle” in the technical specification.
5	APPLICABLE STANDARDS		
	The vehicle must conform to the following standards		
5.1	SANS 1517:2005: - Lubricating oil diesel engines
5.2	SANS 10281:2003 - Sound levels
5.3	SANS 20049:2009 - Particulate pollutants engines (ECE R49.02B)
5.4	SANS 10168:2002 - Restraining devices (safety belts) in vehicles
5.5	SANS 12944-4:2023 - Paints and varnishes – Corrosion protection of steel structures by protective paint systems – Part 4: Types of surface and surface preparation

NO (1)	DESCRIPTION (2) ITEM 6 – TRACK TYPE DOZERS	COMPLY? (3) YES / NO	BROCHURE (4) REFERENCE INFO
5.6	SANS 12944-5:2023 - Paints and varnishes – Corrosion protection of steel structures by protective paint systems – Part 5: Protective paint systems.
5.7	SANS 12944-7:2023 - Paints and varnishes – Corrosion protection of steel structures by protective paint systems – Part 7: Execution and supervision of paint work. D
5.8	ISO 9533: - Audible warning systems
5.9	IEC 60529 IP66 - Ingress protection rating – water and dust
5.10	ISO 3471:2008 - Earth-moving machinery - Roll-over protective structures
5.11	ISO 3449:2005:- Earth-moving machinery - Falling-object protective structures
5.12	ISO 3471, SAE J1040 / ISO 3449, SAE J231: - ROPS / FOPS
5.13	ISO 9246 Capacity Rating Dozer Blades.
5.14	Addendum 13B : General Technical Specifications
6	CHASSIS		
6.1	The chassis is to be constructed from high-strength, welded-alloy steel according to OEM standards.
6.2	The machine must incorporate extensive vulnerable area guarding i.e. such as a) engine and power-train guards b) front-frame guards c) axle-wrapping and seal guards d) fine-mesh air-inlet screen e) under-hood ventilation system f) swing down belly pans, g) a radiator grill guard h) striker bars / cleaner fingers i) or any other equivalent guarding methods.
6.3	Maintenance free trunnion bearings must be incorporated in the design.
6.4	The diesel tank must be positioned for maximum ground clearance
6.5	All fuel tank caps and battery boxes must be lockable
6.6	Tow hooks or attachment points capable of being used to tow the machine onto flat ground for salvage purposes, shall be fitted on the front and rear of machine		
6.7	See Addendum 6.1 for a basic sketch of the vehicle.

NO (1)	DESCRIPTION (2) ITEM 6 – TRACK TYPE DOZERS	COMPLY? (3) YES / NO	BROCHURE (4) REFERENCE INFO
7	ENGINE		
7.1	The compactor must be equipped with a turbocharged common rail diesel engine delivering a maximum net output of not less than 300 kW and maximum net torque of not less than 2000 Nm measured to SANS 10013-1: 2006 standards.
7.2	<p style="text-align: right;">Engine make and model</p> <p style="text-align: right;">Capacity</p> <p style="text-align: right;">Maximum Net Output (Kw @ rpm) @ Sea level</p> <p style="text-align: right;">Maximum Net Torque (Nm @ rpm) @ Sea level</p>	<p>.....</p> <p>.....</p> <p>.....</p> <p>.....</p>	<p>.....</p> <p>.....cc³</p> <p>.....kWrpm</p> <p>.....Nmrpm</p>
7.3	<p>The vehicle emissions under start up and operating conditions shall comply with the International Euro 2 standard as a minimum.</p> <p style="text-align: right;">Euro Standard</p>
7.4	Engine performance curves must be shown in technical brochures.
7.5	The engine is required to operate on proprietary brand lubricating oil to the current applicable standards and in use in the heavy vehicle industry in South Africa.
7.6	The engine oil dipstick, fill point, oil and fuel and any particulate filters, coolant or Adblue reservoirs are to be readily accessible for ease of maintenance.
7.7	The engine and gearbox oil drains must be in easily accessible positions to facilitate emptying without the risk of polluting the environment.
8	ENGINE PROTECTION UNIT (E.P.U.)		
8.1	<p>The vehicle shall incorporate a fail-safe mechanical engine monitoring system which monitors: -</p> <ul style="list-style-type: none"> - oil pressure; - water temperature; - water level; - engine speed
8.2	In the event of a fault condition the EPU shall immediately cut out the engine or decrease engine revs to idle and keep the engine in this state until the fault condition is attended to.
8.3	The service plan is to include the necessary periodic inspection and servicing of all sensors according to OEM requirements
9	TURBO PROTECTION SYSTEM		
9.1	A proprietary protection system shall be fitted to prevent damage to the turbo charger in the event the engine is switched off prematurely, "Turboprotect" or equivalent. If this is a standard fitment then the tenderer is to indicate as such.

NO (1)	DESCRIPTION (2) ITEM 6 – TRACK TYPE DOZERS	COMPLY? (3) YES / NO	BROCHURE (4) REFERENCE INFO
9.2	In addition, the machine must have a delayed engine shutdown facility which shall turn the machine off once the turbo-charger has cooled down to the appropriate temperature.
10	RADIATOR		
10.1	The radiator shall be equipped with cooling fins spaced at an optimum OEM pitch, able to cool at an ambient temperature of up to 40 deg C.
10.2	The radiator is to be protected by a proprietary brand pre filter screen fitted in a radiator guard panel to protect the fins from being clogged by fine particles / dust such as is found at a landfill site.
10.3	Airflow through the pre-filter must be at the correct OEM prescribed level for proper radiator cooling.
10.4	The radiator guard panel is to be easily removed for purposes of cleaning.
10.5	A reversing fan (or reversible fan) is to be incorporated for periodic purging of debris.
10.6	Coolant drains must be placed in an easy to reach position to facilitate emptying without the risk of polluting the environment.
11	TRANSMISSION		
11.1	The vehicle may be powered by: - a) A complete hydrostatic drive transmission or b) An automatic power-shift transmission and matched torque converter or c) Fully automatic transmission with matched torque converter d) Transmission control modules / shift inhibitor to prevent driveline shock loading must be incorporated where necessary.
11.2	For smooth gear shifting, a PWM controlled gearshift system (or similar control method) is to be incorporated. If equivalent systems are offered as standard, the tenderer is to indicate as such.
11.3	In all cases, an oil sample must be taken and sent to a local laboratory (WearCheck or equivalent) for a baseline gearbox oil cleanliness report. Such report shall accompany the machine on delivery.

NO (1)	DESCRIPTION (2) ITEM 6 – TRACK TYPE DOZERS	COMPLY? (3) YES / NO	BROCHURE (4) REFERENCE INFO
11.4	Engine and transmission diagnostics must be possible via connection to a laptop from the vehicles diagnostic port.
12	DRIVE TRACK ASSEMBLY		
13	The drive sprocket shall be elevated and preferably fitted with replaceable bolt on rim segments.
13.1	The final drive should be protected from damage that could be caused by wire and trash that wraps around the sprocket shaft
13.2	The vehicle under carriage shall have track guards welded on with replaceable wear strips and be fitted with no less than 6 rollers per side.
13.3	Idlers and rollers shall be fitted with maintenance free bearings.
13.4	The track tensioners shall be hydraulically operated.
13.5	The track shoes shall be at least 550 mm wide.
13.6	Extreme duty single ribbed grousers shall be fitted.
13.7	Provision shall be made to alleviate the build-up of trash between the tracks and the drive sprocket, rollers and idlers.
14	BRAKES		
14.1	Full details of service brakes, parking brakes, auxiliary brakes and any independent emergency parking brake must be submitted in brochures.
15	STEERING		
15.1	The vehicle shall be equipped with independent electrohydraulic / hydrostatic steering and implement pumps / controls
16	STANDARD SEMI UNIVERSAL BLADE		
16.1	The unit shall be fitted with a standard U shaped blade with a width of at least 3 500 mm, a height of at least 1 500 mm and having a capacity of at least 7 cubic metres.
16.2	The blade is to be of sturdy construction with material such as Hardox 450 or equivalent, being used in the high wear areas.
16.3	A maximum digging depth of not less than 250 mm below ground level is required.
16.4	The blade shall be fitted with bolt-on replaceable cutting edges and corner ends.
16.5	A hydraulic blade tilt facility is required

NO (1)	DESCRIPTION (2) ITEM 6 – TRACK TYPE DOZERS	COMPLY? (3) YES / NO	BROCHURE (4) REFERENCE INFO
16.6	The tilt cylinder and hoses should be adequately protected for operation on the land fill site.
17	RIPPER		
17.1	A standard rear mounted, hydraulically operated, ripper attachment, multi shanked with replaceable tips is required, and should be included in the tender price
17.2	The maximum digging depth shall be at least 600 mm
18	ELECTRICAL SYSTEM		
18.1	The electrical system shall be 24 volt incorporating deep cycle, AGM (absorption glass mat) type batteries.
18.2	The alternator must not be rated less than 80 amp.
18.3	The battery compartment must be lockable and tamper proof.
18.4	An audible reverse warning beeper with an audio output of not less than 90 dB measured at 1 meter be fitted if not supplied as standard fitment.
18.5	A proprietary brand LED type reverse light must be fitted if not supplied as standard fitment.
18.6	The vehicle shall be fitted with a Class 1 Gen 3 (equivalent or better) LED type amber warning light on the compactor cab.
18.7	Class 1 Gen 3 (equivalent or better) LED type work lights shall be mounted on the front and rear of the machine.
18.8	The access stairways must be illuminated with safety lighting Gen 3 LED or equivalent..
18.9	An anti-theft system, Vesa approved, must be fitted to prevent unauthorized engine starting.
18.10	A master disconnect switch must be available at ground switch.
19	CAB		
19.1	The cab shall be weatherproof, lockable, with tinted safety glass windows which shall allow an unobstructed view of all operations.
19.2	The cab shall be ROPS (roll over protection) and FOPS (falling object) protected and shall be installed on anti-vibration mounts onto the chassis.
19.3	The vehicle suspension type must be selected to minimise vibration transmitted to the cab.
19.4	The operator sound pressure level according to ISO		

NO (1)	DESCRIPTION (2) ITEM 6 – TRACK TYPE DOZERS	COMPLY? (3) YES / NO	BROCHURE (4) REFERENCE INFO
	6396:2008 must not be greater than 73 dB(A)
19.5	The operator's seat shall be a heated, air suspension type and be adjustable for rake, position and the mass of the operator, and shall be cushioned and upholstered in durable material. Padded armrests shall be fitted
19.6	Driver seatbelt and passenger seatbelt (if applicable) shall be fitted
19.7	Adequate front and rear wipers and washers shall be fitted
19.8	A proprietary brand AM / FM radio with auxiliary and USB inputs as well as blue tooth functionality, shall be fitted in the event that the vehicle is not supplied with one as a standard fitment.
19.9	The cab shall be fitted with a proprietary brand HVAC climate control system if not a standard fitment. The cab shall be pressurised.
19.10	The cab shall be fitted with a high efficiency particulate air (HEPA) filter system designed to trap microscopic pollutants including pollen, mould and common allergens
19.11	If an hour meter is not offered as standard, then: - a) A non-tamper proof digital hour meter (Hella or equivalent) logging engine hours must be mounted in a convenient and easily visible position on dashboard b) The instrument must have a metering capacity of 9999 hrs with a digital readout of 1/10 th of an hour. c) The meter must be connected to the alternator circuit.
19.12	A proprietary brand reversing camera system with colour LCD monitor shall be installed in the cab "LiftCam HD" or equivalent is to be installed.
20	HYDRAULIC SYSTEM		
20.1	The hydraulic system shall be powered by a variable displacement axial piston pump with a full load sensing system feeding the steering, blade, ripper, fan and brake functions.
20.2	If practical, a ground-driven, load sensing emergency steering pump is to be integrated into the main hydraulic system.

NO (1)	DESCRIPTION (2) ITEM 6 – TRACK TYPE DOZERS	COMPLY? (3) YES / NO	BROCHURE (4) REFERENCE INFO
20.3	The reservoirs must be filled oil to a classification ISO-L-HV in accordance ISO 6743 - 4, viscosity grade 46 hydraulic oil at a VI of at least 140. Shell Tellus S2 V46 or equivalent.
20.4	The cleanliness standards as set out in ISO 4406 and must be equal to or better than 18/16/14.
20.5	Under no circumstances must “new” oil be decanted directly from drums into the reservoir without first going through an oil polishing unit to obtain the required cleanliness level.
20.5.1	The hydraulic oil tank shall incorporate easily accessible and utilise replaceable spin on filters.
20.5.2	Hydraulic pressure check points are to be grouped together in an easily accessible position with standard hydraulic connection points.
21	LUBRICATION		
21.1	The chassis is to incorporate a centralised easily accessible lubrication bank for ease of greasing remote and hard to reach points without the need for crawling under the machine or into awkward unsafe positions.
21.2	If not standard with offer, the tenderer is to offer an auto lubrication system for greasing such remote points as an optional extra.
21.3	Routine checks from the ground level or machine platform are to be undertaken with the ease of operator access in mind.
21.4	Filters are to be grouped and accessed by removable side panels and a remote oil drain must be incorporated. The engine oil check and fill must be undertaken without needing to remove any panels.
22	SPARES HOLDING		
	a) The tenderer shall guarantee here the availability of a full range of spare parts (running and critical), ex stock for the machine within the geographical boundaries of the City of Cape Town. b) Any limitation to the availability shall be explained in a covering letter attached to the tender documents.

NO (1)	DESCRIPTION (2) ITEM 6 – TRACK TYPE DOZERS	COMPLY? (3) YES / NO	BROCHURE (4) REFERENCE INFO
22.1	Tenderers shall state the location of spare parts. Running spares (Same day) Mechanical / driveline spares Body components (interior / exterior)		LOCATION
23	CORROSION PROTECTION		
23.1	The tenderer has to ensure that the protective coating is of a type suitable for a South African coastal environment.
23.2	Paint coatings chosen shall have the same UV, abrasion and corrosion resistance as the following paint program or better :-
23.2.1	Abrasive Blast Cleaning. A Class 2½ “Near White Metal” blast cleanliness, metal preparation.
23.2.2	A proprietary brand two-pack epoxy zinc rich primer for cathodic resistance in harsh corrosive environments
23.2.3	A proprietary brand two-component high gloss acrylic polyurethane top coat
24	WARRANTY		
24.1	VEHICLE		
24.1.1	The complete vehicle must be electrically, mechanically and structurally guaranteed for at least 12 months or 2000 hrs of operation.
24.2	CORROSION		
24.2.1	The complete vehicle shall have at least a 3 year corrosion protection warranty against body rust or paint defects, fair wear and tear excluded.
25	SERVICE PLAN		
25.1	SERVICE PLAN		
25.1.1	A service plan covering the full warranty period of 5 years.
25.1.2	a) Full details of such service plans must be supplied with the tender document or as and when required by the City of Cape Town.
26	OPTIONAL EXTRAS		
26.1	AUTO LUBE SYSTEM		
26.1.1	Supply and installation of a proprietary brand auto lube system for automatic greasing of bearings.

NO (1)	DESCRIPTION (2) ITEM 6 – TRACK TYPE DOZERS	COMPLY? (3) YES / NO	BROCHURE (4) REFERENCE INFO
26.2	FIRE SUPPRESSION SYSTEM		
26.2.1	The tenderer is to offer a proprietary brand dual agent - DCP and aqueous film forming foam liquid fire suppressant system (Ansulite or similar) as an optional extra. The specified fire suppression system shall incorporate:-
26.2.2	a) Sufficient and appropriately placed fire-detecting sensing manifold pipes.
26.2.3	b) A control panel in the cab to detect a fire and alert the operator
26.2.4	c) Actuators to discharge suppressant automatically and manually
26.2.5	d) Tanks filled with fire suppressant DCP and aqueous film forming foam (Ansulite or similar)
26.2.6	e) Distribution network of tubes, hoses, and nozzles
26.2.7	It is essential that fitment of the fire suppression system be done by a registered qualified artisan / technician in terms of South African legislation set out in this regard.
26.2.8	The fire suppression system shall carry a 3 year warranty from the date of handover.
26.2.9	The City of Cape Town reserves the right to view the tenderers compliance in this regard as and when it deems fit to do so.
26.3	WEST COAST CORROSION PROTECTION		
26.3.1	The tenderer has to ensure that the corrosion protective coating is of a type suitable for a South African coastal environment. i.e. Carbo-mastic spec or equivalent		
26.3.2	Paint coatings chosen shall have the same UV, abrasion and corrosion resistance as the following paint program or better :-		
a)	Abrasive Blast Cleaning. A Class 2½ “Near White Metal” blast cleanliness, metal preparation.		
b)	A proprietary brand two-pack epoxy zinc rich primer for cathodic resistance in harsh corrosive environments		
c)	A proprietary brand two-component high gloss acrylic polyurethane top coat		
d)	The paint offered shall have at least a 5 year corrosion protection following marine quality international standard i.e. Carbo-mastic spec or equivalent.		

NO (1)	DESCRIPTION (2) ITEM 6 – TRACK TYPE DOZERS	COMPLY? (3) YES / NO	BROCHURE (4) REFERENCE INFO
e)	The above paints are to be applied in accordance with the manufacturer's recommendations. The Contractor shall arrange for a suitable inspection authority to attend to each stage, approve and submit a report on the application		
27	MANUALS AND TRAINING		
27.1	Properly bound, original approved OEM operators, service and parts manuals in the English language must be provided on delivery.
27.2	a) Training for operators in the proper operation of the vehicle must be provided and included in the tendered price. b) Training for 4 candidates must be provided within two weeks of delivery of the vehicle or as and when required by the City of Cape Town
28	DELIVERY		
28.1	The vehicle shall be registered in the name of the City of Cape Town.
28.2	The cost of licensing, registration, number plates, etc. must be included in the price of the vehicle
28.3	The vehicle shall have permanent manufacturers plates whereupon relevant data is stamped i.e. the manufacturers name, model no, serial number, and year of manufacture. The plates are to be fixed as per OEM instructions.
28.4	The delivery cost must form part of the main item in the pricing schedule. The transportation of the vehicle must adhere to legal and safety regulations applicable.
28.5	Essential operator tools to allow the operator to perform running maintenance is required.
28.6	State whether any free services are included in the tendered price and where such services will be carried out.
28.7	Pre- delivery service cost must be included in the tender price
28.8	Any unacceptable delays in delivery ensuing will attract prescribed penalties.

ADDENDUM 6.1

This is a depiction of the type of vehicle required and not to be construed as the brand required.

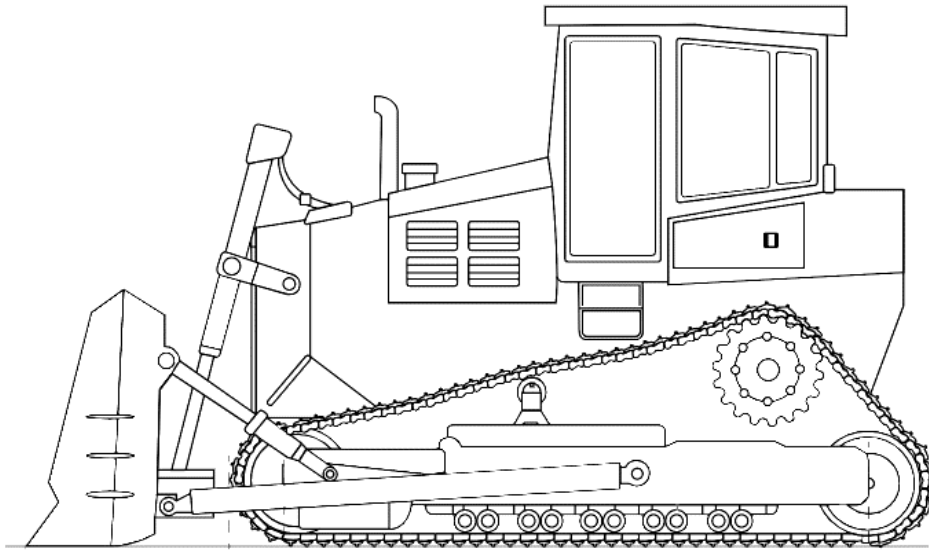

13. SECTION B: GENERAL TECHNICAL SPECIFICATIONS**13.1. GENERAL REQUIREMENTS**

- 13.1.1. This tenderer is for the supply and delivery of landfill plant and equipment conforming to the technical specification. Where applicable all road legal earthmoving equipment shall be first registered in the City of Cape Town name.
- 13.1.2. The tenderer shall supply documentary proof that they are registered as a motor dealer/manufacturer in terms of the National Road Traffic Act of 1996 or a covering letter an OEM confirmation that they are approved as an earthmoving plant/equipment distributor and will provide parts and maintenance of the equipment.
- 13.1.3. The tenderer shall have access to fully equipped facilities which are OEM approved for the maintenance, repair, testing and major overhauls of the plant equipment offered. Tenderers must provide either a letter from the OEM or a copy of the Service Level Agreement (SLA) with their service provider indicating that the facilities offered are OEM approved for the maintenance, repair, testing and major overhauls of the machine offered while under warranty. The location of the proposed service facility and a contact name shall be supplied. Tenderers will be permitted time to establish a workshop within 90 days, within the geographical boundaries of the City of Cape Town as detailed in the Special Conditions of Contract Clause 36.
- 13.1.4. The tenderer shall guarantee the availability of a full range of spare parts, ex stock, in the Cape Metropolitan area at all reasonable hours. Tenderers shall state the availability of spare parts and the relevant parts stock value. Where these are held in the technical specification. Any limitation to these requirements shall be explained in a covering letter.
- 13.1.5. All tender documents are to be scanned into a PDF format, and stored onto a CD or a flash drive which is to be submitted with the tender offering. Scanning in picture format will not be accepted.

13.2. WARNING SIGNS

- 13.2.1. The earthmoving machinery where so required in terms of the Road Traffic Act No 93 of 1996, as amended, shall fully comply & have fitted on the back thereof the prescribed warning signs as required by the said Act. It shall be fitted with the 3M – Orange/ Red diamond grade conspicuity marking code: 983-71ECE mark or equivalent standard in consultation with the City of Cape Town's representative.
- 13.2.2. A minimum of Emergency Warning Sign (warning triangles), in accordance with the requirements of the Road Traffic Act No 93 of 1996, shall be provided with each machine. These triangles shall be stored, clipped or otherwise secured in a conveniently accessible but protected position in the driver's cab.

13.3. REGISTRATION PLATES (NUMBER PLATES)

- 13.3.1. The machine shall be supplied and fitted with registration plates and shall be displayed in a manner which complies with the standard specification of the SABS for retro-reflective registration plates (SABS 1116 of 1982). The number plates shall be secured by rivets or by bolt and nut in accordance with the Road Traffic Act No 93 of 1996 as amended.
- 13.3.2. These plates shall be clearly visible under all circumstances even when the tailboard, where fitted, is lowered.
- 13.3.3. No selling dealer name or other wording shall be incorporated in the surround.

13.4. WARRANTY AND MAINTENANCE OF ANCILLARY EQUIPMENT

- 13.4.1. Tenderers are requested to state, where ancillary equipment other than that of the local manufacture is offered, the name of the local firm appointed by the Manufacturer for the purpose of warranty and maintenance of the offered equipment.

- 13.4.2. An OEM approved separate electrical junction box/board (MPI Safestop or equivalent) shall be fitted for the power supply of auxiliary equipment e.g. vehicle monitoring and tracking system and other aftermarket systems the City of Cape Town have fitted to their vehicles. The junction box / board must make provision for both 12V and 24V supplies. The fitment of the accessory junction box must in no way compromise the OEM warranty requirements of the vehicle.
- 13.4.3. City of Cape Town will be fitting a machine monitoring system as well as a fuel management system to each machine. The fitting of these management systems shall not have an effect on the OEM warranty.

13.5. THE OCCUPATIONAL HEALTH AND SAFETY ACT 1993

- 13.5.1. The tenderer must ensure that they comply with the related regulations as stipulated in the applicable acts and codes of practice associated with the Act.
- 13.5.2. All auxiliary machinery fitted to a machine shall comply with the Occupational Health and Safety Act No 85 of 1993 as amended, and the Regulations framed there under.

13.6. RUSTPROOFING

- 13.6.1. The item offered shall have a full three-year Manufacturer's warranty against rust and discolouration.
- 13.6.2. Should any additional accessories, such as lights, have to be fitted to the manufactured bodywork, the rustproofing of the holes and interface between the accessories attached and the original body shall be of the best practise and to the approval of the City of Cape Town's representative.

13.7. SPECIFICATIONS

- 13.7.1. Notwithstanding anything to the contrary contained in these specifications offers of all machines / plant equipment, where applicable shall comply with the latest applicable standards, latest SANS Compulsory Machine Standards requirements as well as the Road Traffic Act No 93 of 1996 as amended.

13.8. WARNING LIGHTS / FLOOD LAMPS / SPOT LAMPS / WORK LIGHTS

- 13.8.1. Only Class 1, Gen 111 (or better) LED type warning lights / flood lamps, spot lamps, work lights, light bars, clusters and beacons may be fitted.
- 13.8.2. LED lights must conform to SAEJ595 and SAEJ845 where applicable.
- 13.8.3. LED warning lights shall be amber in colour.
- 13.8.4. Sufficient warning lights shall be fitted to make the machine visible from front, rear and both sides.
- 13.8.5. The outer lenses shall be of high impact UV protected polycarbonate available in clear or as specified under specific machine specification clauses.
- 13.8.6. The light fittings shall be completely sealed against the ingress of dust and moisture i.e. IP65 rated.
- 13.8.7. The lights shall be controlled by a dashboard mounted switch wired independently of the ignition.
- 13.8.8. No holes are to be drilled into the machine roof. Rubber or plastic inserts or linings shall be used to prevent damage to the paint work.
- 13.8.9. All fasteners used in fixtures shall be stainless steel.
- 13.8.10. Flood lights / spot lights / work light bodies, when fitted, are to be of a robust die cast aluminium construction with grade 304 stainless steel bracket mounts and bolts / washers enabling rotation and tilting.
- 13.8.11. The light output of flood lamps / work lights or spot lights must be at least 20W.

- 13.8.12. The lights must be able to be powered by the battery bank of the vehicle and rated at the total voltage of the battery bank. Under no circumstances shall current for accessories be drawn from a single battery in a dual battery system. Accessories requiring 12V must utilize a proprietary brand OEM approved voltage reducer.
- 13.8.13. The units plus fitment must be fully guaranteed for at least 3 years normal wear and tear as well as ultra violet protection against fading or cracking of the polycarbonate lens.

13.9. DECALS

- 13.9.1. Decals will be supplied by the Solid Waste Management Fleet to the successful tenderer and these will have to be fitted by the tenderer to the machines in consultation with the City of Cape Town's representative before delivery.

13.10. VEHICLE MONITORING SYSTEM

- 13.10.1. It is required that the vehicles on board computer system be able to support the fitment of the City of Cape Town's vehicle monitoring system monitoring of, but not limited to, engine hours, engine temperature, fuel tank level, GPS position and remote engine shutdown.

13.11. ON ROAD FUELLING SYSTEM

- 13.11.1. The City of Cape Town's fleet is currently fitted with an on road fuelling system. The on road fuelling system allows for odometer/hour meter readings to be taken direct from the machine. If the machine offered by the tenderer cannot provide accurate odometer readings, then the City of Cape Town will hold the tenderer liable for all costs to obtain accurate odometer reading via alternative methods. The fitment of the on road fuelling system must in no means have any effect on the vehicles Original Equipment Manufacturers warranties.

13.12. EMISSIONS CONTROL ACT

- 13.12.1. The City Of Cape Town is embarking on a programme which will ensure that all their machines supplied on tenders comply with their initiatives to reduce carbon emissions.

As a minimum all current machines supplied must comply with the following:

- 13.12.2. Machines shall meet a minimum emission standard of Tier 3 or equivalent
- 13.12.3. The Atmospheric Pollution Prevention Act, 1965 (Act 45 of 1965)
- 13.12.4. The requirements as laid out in the Government Gazette 3324 of 2003
- 13.12.5. Standards as specified in Government Gazette No 27409 of 1 April 2005 (when these become applicable)
- 13.12.6. The City of Cape Town: Air Pollution Control By-law 12649 of 4 February 2003
- 13.12.7. National Environmental Management: Air Quality Act No 39 of 2004

form Tenderers are to articulate its environmental responsiveness in terms of their organisation in the of a covering letter submitted with tender submission or as and when requested by the City of Cape Town.

13.13. GUARANTEE

- 13.13.1. The tenderer must give an express warrantee that all goods covered by this contract are satisfactory design, material, parts and workmanship and is fit for the purpose for they are required and in addition will warrant all materials, parts and workmanship against latent defects.
- 13.13.2. City of Cape Town's has standardised on installing automated fuel systems to its' Fleet. Manufacturers must ensure that the electronic equipment of all offers submitted is compatible for the retro fitment of the selected unit. City of Cape Town undertakes to discuss their fuel systems fitted on their fleet with the manufacturers prior to entering into any agreements. It must be noted that the fitment of Automated Fuel Systems must have no impact on the machine warranty. City of Cape Town will not entertain any disputes from the successful tender with regards to the fitment of these systems. The successful tenderer will be held responsible for the complete product.

14. TRADE NAMES OR PROPRIETARY PRODUCTS

Tenderers/Suppliers must note that wherever this document refers to any particular trade mark, name, patent, design, type, specific origin or producer, such reference shall be deemed to be accompanied by the words “or equivalent”.

15. EMPLOYMENT OF SECURITY PERSONNEL

All security staff employed by the Supplier on behalf of the CCT or at any CCT property must be registered with Private Security Industry Regulatory Authority (PSiRA). Proof of such registration must be made available to the CCT or its agent, upon request.

16. FORMS FOR CONTRACT ADMINISTRATION

The Supplier shall complete, sign and submit with each invoice, the following:

- a) Monthly Project Labour Report (described below)

Not applicable

C.6 SPECIAL CONDITIONS OF CONTRACT

The following Special Conditions of Contract, referring to the National Treasury – Conditions of Contract (revised July 2010), are applicable to this agreement.

1. Definitions

Insert new clause 1.1A with the following:

- 1.1A “Commencement Date” means the date the Supplier confirms receipt from the Purchaser of 1 (one) complete, signed copy of the Contract, the *Schedule of Deviations* (if any).
- 1.1B “Conditions of Contract” means the general conditions of contract and special conditions of contract including all other contract data incorporated by reference.

Delete Clause 1.15 and substitute with the following

- 1.15 The word ‘Goods’ is to be replaced everywhere it occurs in the GCC with the phrase ‘Goods and / or Services’ which means all of the equipment, machinery, materials, services, products, consumables, etc. that the Supplier is required to deliver to the Purchaser under the agreement. This definition shall also be applicable, as the context requires, anywhere where the words “supplies” and “services” occurs in the GCC.

Delete Clause 1.19 and substitute with the following

- 1.19 The word ‘Order’ is to be replaced everywhere it occurs in the GCC with the words ‘Purchase Order’ which means the official purchase order authorised and released on the Purchaser’s SAP System.

Delete Clause 1.21 and substitute with the following:

- 1.21 ‘Purchaser’ means the City of Cape Town. The address of the Purchaser is 12 Hertzog Boulevard, Cape Town, 8001 (chosen domicilium citandi et executandi).

Add the following after Clause 1.25:

- 1.26 ‘Supplier’ means the provider of Goods and / or Services with whom the Contract is concluded also referred to as “contractor” in the GCC.
- 1.27 "Intellectual Property" means any and all intellectual property rights of any nature anywhere in the world whether registered, registerable or otherwise, including patents, trademarks, registered designs and domain names, applications for any of the foregoing, trade or business names, copyright and rights in the nature of copyright, design rights, rights in databases, know-how, trade secrets and any other intellectual property rights which subsist in computer software, computer programs, websites, documents, information, techniques, business methods, drawings, logos, instruction manuals, lists and procedures and particulars of customers, marketing methods and procedures and advertising literature, including the "look and feel" of any websites
- 1.28 “Working Day” means Monday to Friday excluding weekends and Public Holidays (in the Republic of Sotuh Africa).

3. General Obligations

Delete Clause 3.2 in its entirety and replace with the following clauses.

- 3.2 The Parties will be liable to each other arising out of or in connection with any breach of the obligations detailed or implied in this contract, subject to clause 28.
- 3.3 If the Supplier is a joint venture, all parties in a joint venture or consortium shall be jointly and severally liable to the Purchaser in terms of the Contract and shall carry individually the minimum levels of insurance stated in the Contract, if any.

- 3.4 The Parties shall comply with all laws, regulations and bylaws of local or other authorities having jurisdiction regarding the Delivery of the Goods and/or Services and give all notices and pay all charges required by such authorities.
- 3.4.1 The Parties agree that this Contract shall also be subject to the CCT's Supply Chain Management Policy ("SCM Policy") that was applicable on the date the bid was advertised as amended from time to time. If the Purchaser adopts a new SCM Policy which contemplates that any clause therein would apply to the Contract emanating from this tender, such clause shall also be applicable to the Contract. Please refer to this document contained on the CCT's website.
- 3.4.2 Abuse of the supply chain management system is not permitted and may result in termination of the Contract, restriction of the Supplier, and/or the exercise by the CCT of any other remedies available to it as described in the SCM Policy or in law.
- 3.5 The Supplier shall:
- 3.5.1 Arrange for the documents listed below to be provided to the Purchaser prior to the issuing of the Purchase Order by the Purchaser and no later than the periods as set out in the Contract:
- a) Proof of Insurance (Refer to Clause 11) or Insurance Broker's Warrantee,
 - b) Letter of good standing from the Compensation Commissioner, or a licensed compensation insurer (Refer to Clause 11),
 - c) Initial delivery programme, and
 - d) Other requirements as detailed in the Contract.
- 3.5.2 Only when notified of the acceptance of the bid on the Date of Commencement of Contract, the Supplier shall commence with and carry out the Delivery of the Goods and/or Services in accordance with the Contract, to the satisfaction, of the Purchaser.
- 3.5.3 Provide all of the necessary materials, labour, plant and equipment required for the delivery of the Goods and/or Services including any temporary services that may be required.
- 3.5.4 Insure his workmen and employees against death or injury arising out of the delivery of the Goods.
- 3.5.5 Be continuously represented during the Delivery of the Goods and/or Services by a competent representative duly authorised to execute instructions.
- 3.5.6 In the event of a loss resulting in a claim against the insurance policies stated in clause 11, pay the first amount (excess) as required by the insurance policy.
- 3.5.7 Comply with all written instructions from the Purchaser subject to clause 18.
- 3.5.8 Complete and Deliver the goods within the period stated in clause 10, or any extensions thereof in terms of clause 21.
- 3.5.9 Make good at his own expense, all incomplete and defective Goods during the warranty period.
- 3.5.10 Pay to the Purchaser any penalty for delay as due on demand by the Purchaser. The Supplier hereby consents to such amounts being deducted from any payment due to the Supplier.
- 3.5.11 Comply with the provisions of the OHAS Act & all relevant regulations.
- 3.5.12 Comply with all laws relating to wages and conditions generally governing the employment of labour in the Cape Town area and any applicable Bargaining Council agreements.
- 3.5.13 Deliver the Goods in accordance with the Contract and with all reasonable care, diligence and skill in accordance with generally accepted professional techniques and standards.
- 3.6 The Purchaser shall:
- 3.6.1 Issue Purchaser Orders for the Goods and/or Services required under this Contract. No liability for payment will ensue for arising out of the Delivery of the Goods and/or Services, unless a Purchase Order has been issued to the Supplier.

- 3.6.2 Make payment to the Supplier for the Goods and/or Services as set out herein.
- 3.6.3 Take possession of the Goods and /or Services upon Delivery by the Supplier.
- 3.6.4 Regularly inspect the Goods to establish that it is being delivered in compliance with the Contract.
- 3.6.5 Give any instructions and/or explanations and/or variations to the Supplier including any relevant advice to assist the Supplier to understand the Contract.
- 3.6.6 Grant or refuse any extension of time requested by the Supplier of the period stated in clause 10.
- 3.6.7 Inspect the Goods and/or Services to determine if, in the opinion of the Purchaser, it has been delivered in compliance with the Contract, alternatively in such a state that it can be properly used for the purpose for which it was intended.
- 3.6.8 Brief the Supplier and issue all documents, information, etc. in accordance with the contract.

5. Use of contract documents and information; inspection, copyright, confidentiality, etc.

Add the following after clause 5.4:

- 5.5 Copyright of all documents prepared by the Supplier in accordance with the relevant provisions of the Copyright Act (Act 98 of 1978) relating to the Contract shall be vested in the Purchaser. Where copyright is vested in the Supplier, the Purchaser shall be entitled to use the documents or copy them only for the purposes for which they are intended in regard to the agreement and need not obtain the Supplier's permission to copy it for such use. Where copyright is vested in the Purchaser, the Supplier shall not be liable in any way for the use of any of the information other than as originally intended in terms of the agreement and the Purchaser hereby indemnifies the Supplier against any claim which may be made against it by any person / entity, arising from the use of such documentation for other purposes.

The ownership of data and factual information collected by the Supplier and paid for by the Purchaser shall, after payment, vest with the Purchaser.

- 5.6 **Publicity and publication**
The Supplier shall not release public or media statements or publish material related to the services or agreement within two (2) years of Delivery of the Goods, without the written approval of the Purchaser, which approval shall not be unreasonably withheld.
- 5.7 **Confidentiality**
Both Parties shall keep all information obtained by them in the context of the agreement, confidential and shall not divulge it without the written approval of the other Party.
- 5.8 **Intellectual Property**
 - 5.8.1 The Supplier acknowledges that it shall not acquire any right, title or interest in or to the Intellectual Property of the Purchaser.
 - 5.8.2 The Supplier hereby assigns to the Purchaser, all Intellectual Property created, developed or otherwise brought into existence by it for the purposes of the agreement, unless the Parties expressly agree otherwise in writing.
 - 5.8.3 The Supplier shall, and warrants that it shall:
 - 5.8.3.1 Not be entitled to use the Purchaser's Intellectual Property for any purpose other than as contemplated in the agreement;
 - 5.8.3.2 not modify, add to, change or alter the Purchaser's Intellectual Property, or any information or data related thereto, nor may the Supplier produce any product as a result of, including and/or arising from any such information, data and Intellectual Property, and in the event that it does produce any such product, the product shall be, and be deemed in law to be, owned by the Purchaser;
 - 5.8.3.3 Not apply for or obtain registration of any domain name, trademark or design which is similar to any Intellectual Property of the Purchaser;

- 5.8.3.4 Comply with all reasonable directions or instructions given to it by the Purchaser in relation to the form and manner of use of the CCT Intellectual Property, including without limitation, any brand guidelines which the Purchaser may provide to the Supplier from time to time;
- 5.8.3.5 Ensure that its employees, directors, members and contractors comply strictly with the provisions of this Clause 5.8.4 above unless the Purchaser expressly agrees to the contrary, in writing and only after obtaining due internal authority for such agreement.
- 5.8.4 The Supplier represents and warrants to the Purchaser that, in providing Goods and/or Services for the duration of the agreement it will not infringe or make unauthorised use of the Intellectual Property rights of any third party and hereby indemnifies the Purchaser from any claims, liability, loss, damages, costs, and expenses arising from the infringement or unauthorised use by the Supplier of any third party's Intellectual Property rights.
- 5.8.5 Upon expiry of the contract period and in the event that the Contract is terminated, ended or is declared void, any and all of the Purchaser's Intellectual Property, and any and all information and data related thereto, shall be immediately handed over to the Purchaser by the Supplier and no copies thereof shall be retained by the Supplier unless the Purchaser expressly and in writing, after obtaining due internal authority, agrees otherwise.

Add the following after clause 5.8:

5.9 **Protection of Personal Information Act of 2013**

By submitting a tender to the Purchaser, (and by concluding any ensuing related agreement with the City of Cape Town, if applicable), the Tenderer thereby acknowledges and unconditionally agrees:

- 5.9.1 that the tenderer has been informed of the purpose of the collection and processing of its personal information as defined in the Protection of Personal Information Act of 2013 ("POPIA"), which, for the avoidance of doubt is for, and in relation to, the tender process and the negotiation, conclusion, performance and enforcement of the ensuing agreement, if applicable, as well as for the City of Cape Town's reporting purposes;
- 5.9.2 to the collection and processing of the tenderer's personal information by the City of Cape Town and agrees to make available to the City of Cape Town, all information reasonably required by the City of Cape Town for the above purposes;
- 5.9.3 that the personal information the City of Cape Town collects from the tenderer or about the tenderer may be further processed for other activities and/or purposes which are lawful, reasonable, relevant and not excessive in relation to the purposes set out above, for which it was originally collected;
- 5.9.4 that, the tenderer indemnifies the City of Cape Town and its officials, employees, and directors and undertakes to keep the City of Cape Town and its officials, employees, and directors indemnified in respect of any claim, loss, demands, liability, costs and expenses of whatsoever nature which may be made against the City of Cape Town (including the costs incurred in defending or contesting any such claim) in relation to the tenderer or the tenderer's employees', representatives' and/or sub-Suppliers' non-compliance with POPIA and/or the City of Cape Town's failure to obtain the tenderer's consent or to notify the tenderer of the reason for the processing of the tenderer's personal information;
- 5.9.5 to the disclosure of the tenderer's personal information by the City of Cape Town to any third party, where the City of Cape Town has a legal or contractual obligation to disclose such personal information to the third party (or a legitimate interest exists therein);
- 5.9.6 that, under POPIA, the tenderer may request to access, confirm, request the correction, destruction, or deletion of, or request a description of, personal information held by the City of Cape Town in relation to you, subject to applicable law; and

that under POPIA, subject to applicable law, the tenderer also has the right to be notified of a personal information breach and the right to object to, or restrict, the City of Cape Town's processing of its personal information.

5.10 **PERFORMANCE MONITORING**

- 5.10.1 As required by section 116(2)(b) of the Local Government: Municipal Financial Management Act 56 of 2003, the CCT shall monitor the performance of the Supplier on at least a monthly basis, and the Supplier agrees to provide the CCT with its full cooperation in this regard.

7. Performance Security

Delete clause 7.1 to 7.4 and replace with the following:

Not Applicable. Tenderers must disregard the **Pro Forma Performance Security/ Guarantee** and are not required to furnish same.

8. Inspections, tests and analyses

Delete Clause 8.2 and substitute with the following:

- 8.2 If it is a bid condition that Goods and/or Services to be produced or services to be rendered should at any stage during production or execution or on completion be subject to inspection, the premises of the bidder or Supplier shall be open, at all reasonable hours, for inspection by a representative of the Purchaser or an organisation acting on behalf of the Purchaser.

10. Delivery and documents

Delete clauses 10.1 and 10.2 and replace with the following:

- 10.1 Delivery of the goods shall be made by the Supplier in accordance with the terms specified in the contract. The time for Delivery of the goods shall be the date as stated on the Purchase Order. In the case of agreements for Delivery of goods in terms of framework or panel agreements, Purchase Orders for the supply and delivery of goods may be raised up until the expiry of a framework or panel agreement, provided that the goods can be delivered within 30 (thirty) days of expiry of the framework or panel agreement. In this context, the "goods" does not include services and carries its ordinary meaning. All Purchase Orders other than for the supply and Delivery of goods (i.e. supply of services, professional services or constructions works), must be completed prior to the expiry of the contract period.
- 10.2 The Purchaser shall determine, in its sole discretion, whether the Goods and/or Services have been delivered in compliance with the Contract, alternatively in such a state that it can be properly used for the purpose for which it was intended. When the Purchaser determines that the Goods and/or Services have been satisfactorily delivered, the Purchaser must issue an appropriate certification, or written approval, to that effect. Invoicing may only occur, and must be dated, on or after the date of such written acceptance of the Goods.

11. Insurance

Add the following after clause 11.1:

- 11.2 Without limiting the obligations of the Supplier in terms of this Contract, the Supplier shall effect and maintain the following additional insurances:
- 11.2.1 Public liability insurances, in the name of the Supplier, covering the Supplier and the Purchaser against liability for the death of or injury to any person, or loss of or damage to any property, arising out of or in the course of this Contract, in an amount not less than **[R20 million]** for any single claim;
- 11.2.2 Motor Vehicle Liability Insurance, in respect of all vehicles owned and / or leased by the Supplier, comprising (as a minimum) "Balance of Third Party" Risks including Passenger Liability Indemnity;
- 11.2.3 Registration / insurance in terms of the Compensation for Occupational Injuries and Disease Act, Act 130 of 1993. This can either take the form of a certified copy of a valid Letter of Good Standing issued by the Compensation Commissioner, or proof of insurance with a licenced compensation insurer, from either the Supplier's broker or the insurance company itself (see the Pro Forma Insurance Broker's Warranty).

11.2.4 In the event of under insurance or the insurer's repudiation of any claim for whatever reason, the Purchaser will retain its right of recourse against the Supplier.

11.3 The Supplier shall be obliged to furnish the Purchaser with proof of such insurance as the Purchaser may require from time to time for the duration of this Contract. Evidence that the insurances have been effected in terms of this clause, shall be either in the form of an insurance broker's warranty worded precisely as per the pro forma version contained in the Pro forma Insurance Broker's Warranty or copies of the insurance policies.

15. Warranty

Add to Clause 15.2:

15.2 The warranty for this Contract shall remain valid for six (6) months from date of Delivery of the Goods and/or Services.

16. Payment

Delete Clause 16.1 in its entirety and replace with the following:

16.1 Payment of invoices will be made:

16.1.1 Within 30 (thirty) days of receiving the relevant invoice or statement from the Supplier, unless otherwise prescribed for certain categories of expenditure or specific contractual requirements in accordance with any other applicable policies of the Purchaser.

16.1.2 Notwithstanding anything contained above, the Purchaser shall not be liable for payment of any invoice that pre-dates the date of delivery of any Goods and/or Services.

Delete Clause 16.2 in its entirety and replace with the following:

16.2 The Supplier shall furnish the purchaser's Accounts Payable Department with an original tax invoice, clearly showing the amount due in respect of each and every claim for payment.

Add the following after clause 16.4

16.5 Notwithstanding any amount stated on the Purchase Order, the Supplier shall only be entitled to payment for Goods and/or Services actually delivered in terms of the Specification and Drawings, or any variations thereof made in accordance with clause 18. Any contingency sum included shall be for the sole use, and at the discretion, of the Purchaser.

16.6 The Purchaser will only make advanced payments to the Supplier in strict compliance with the terms and conditions as contained in the Pro forma Advanced Payment Guarantee and only once the authenticity of such guarantee has been verified by the Purchaser's Treasury Department.

17. Prices

Add the following after clause 17.1

17.2 If as a result of an award of a contract beyond the original tender validity period, the contract execution will be completed beyond a period of twelve (12) months from the expiry of the original tender validity period, then the contract may be subject to contract price adjustment for that period beyond such twelve (12) months. An appropriate contract price adjustment formula will be determined by the Purchaser delegated authority if such was not included in the bid documents.

17.3 If as a result of any extension of time granted, the contract execution will be completed beyond a period of twelve (12) months from the expiry of the original tender validity period, then contract price adjustment may apply to that period beyond such twelve (12) months. An appropriate contract price adjustment formula will be determined by the Director: Supply Chain Management if such was not included in the bid documents.

- 17.4 The prices for the goods and/or Services delivered and services performed shall be subject to contract price adjustment in terms of Schedule F.1 Contract Price Adjustment and/or Rate of Exchange Variations and the following conditions will be applicable:

Refer to Schedule F I: Contract Price Adjustment and/or Rate of Exchange Variations

18. Contract Amendments

Delete the heading of clause 18 and replace with the following:

18. Contract Amendments and Variations

Add the following to clause 18.1:

Variations means changes to the Goods and/or Services, extension of the contract period or increases in the value of the Contract as a result of written instructions issued by the Purchaser to the Supplier. Such changes are subject to prior approval by the Purchaser's delegated authority. Should the Supplier deliver any Goods not described in a written instruction from the Purchaser, the Purchaser's liability for payment shall no arise until such time as the change has been duly approved and such approval communicated to the Purchaser.

20. Subcontracts

Add the following after clause 20.1:

- 20.2 The Supplier shall be liable for the acts, defaults and negligence of any subcontractor, his agents or employees as fully as if they were the acts, defaults or negligence of the Supplier.
- 20.3 Any appointment of a subcontractor shall not amount to a contract between the Purchaser and the subcontractor, or a responsibility or liability on the part of the Purchaser to the subcontractor and shall not relieve the Supplier from any liability or obligation under the Contract.

21. Delays in the supplier's performance

Delete Clause 21.2 in its entirety and replace with the following:

- 21.2 If at any time during the performance of obligations contained in the Contract the Supplier or its subcontractors should encounter conditions beyond their reasonable control which impede the timely delivery of the Goods and/or Services, the Supplier shall notify the Purchaser in writing, within 7 (seven) days of first having become aware of these conditions, of the facts of the delay, its cause(s) and its probable duration. As soon as practicable after receipt of the Supplier's notice, the Purchaser shall evaluate the situation, and may at his discretion extend the time for Delivery.

Where additional time is granted, the Purchaser shall also determine whether or not the Supplier is entitled to payment for additional costs in respect thereof. The principle to be applied in this regard is that where the Purchaser or any of its agents are responsible for the delay, reasonable costs shall be paid. In respect of delays that were beyond the reasonable control of both the Supplier and the Purchaser, additional time only (no costs) will be granted.

The Purchaser shall notify the Supplier in writing of his decision(s) in the above regard.

- 21.3 No provision in this Contract shall be deemed to prohibit the obtaining of Goods and/or Services from a national department, provincial department, or a local authority.

22. Penalties

Delete clause 22.1 and replace with the following:

- 22.1 Subject to GCC Clause 25, if the Supplier fails to deliver any or all of the Goods and/or Services within the period(s) specified in the Contract, the Purchaser shall, without prejudice to its other remedies under the Contract, deduct from amounts payable, as a penalty, a sum as stated herein for each day of the delay until actual Delivery or performance.

The penalty for this contract shall be, effective immediately after the end of the delivery period indicated in the Price Schedule:

- Week 1: 1 - 7 days of late delivery = 2% of the purchase order amount;
- Week 2: 8 - 14 days of late delivery = 4% of the purchase order amount;
- Week 3: 15 - 21 days of late delivery = 6% of the purchase order amount;
- Above 21 days of late delivery = 10% of the purchase order amount will apply.

22.2 The Purchaser shall, without prejudice to its other remedies under the contract, deduct from amounts payable, financial penalties as contained on the Preference Schedule for breaches of the conditions upon which preference points were awarded.

23. Termination for default

Delete the heading of clause 23 and replace with the following:

23. Termination

Add the following to the end of clause 23.1:

If the Supplier fails to remedy the breach in terms of such notice.

Add the following after clause 23.7:

23.8 In addition to the grounds for termination due to default by the Supplier, the Contract may also be terminated:

23.8.1 Upon the death of the Supplier who was a Sole Proprietor, or a sole member of a Close Corporation, in which case the contract will terminate forthwith.

23.8.2 If the Parties, by mutual agreement, terminate the Contract.

23.8.3 If a material irregularity vitiates the procurement process leading to the conclusion of the Contract, rendering the procurement process and the conclusion of the resulting Contract unfair, inequitable, non-transparent, uncompetitive or not cost-effective the Contract may be terminated by the Purchaser (upon conclusion of applicable processes by the City Manager as described in the Purchaser's SCM Policy).

23.8.4 Reputational risk or harm to the Purchaser

The Purchaser, without prejudice to any other remedy for breach of contract, by written notice of default sent to the Supplier, may terminate the contract if the implementation of the contract may result in reputational risk or harm to the Purchaser as a result of (inter alia):

- a) reports of poor governance and/or unethical behaviour;
- b) association with known notorious individuals and family of notorious individuals;
- c) poor performance issues, known to the Purchaser
- d) negative social media reports;
- e) adverse assurance (e.g. due diligence) report outcomes; or
- f) circumstances where the relevant vendor has employed, or is directed by, anyone who was previously employed in the service of the state (as defined in clause 1.53), where the person is or was negatively implicated in any SCM irregularity.

By or in relation to the Supplier, the Contract may be terminated by the Purchaser after providing notice to the Supplier.

23.9 If the Contract is terminated in terms of clause 23.8, all obligations that were due and enforceable prior to the date of the termination, must be performed by the relevant Party.

26. Termination for insolvency

Delete clause 26.1 and replace with the following:

26.1 In the event of the Supplier becoming bankrupt or otherwise insolvent the Purchaser may elect to:

26.1.1 At any time, terminate the Contract by giving written notice to the Supplier; or

26.1.2 Accept a Supplier's proposal (via the liquidator) to render delivery utilising the appropriate contractual mechanisms or takes steps to ensure its rights are protected and any negative impact on service delivery is mitigated.

26.2 In the event of the Purchaser electing to cancel the Contract in accordance with clause 26.1.1 above, the Purchaser shall make payment of all verified and signed off invoices. In the event of there being any dispute in respect of any outstanding invoices such dispute shall be dealt with in accordance with the dispute resolution mechanism in the Contract.

27. Settlement of Disputes

Amend clause 27.1 as follows:

27.1 If any dispute or difference of any kind whatsoever, with the exception of termination in terms of clause 23 arises between the Purchaser and the Supplier in connection with or arising out of the Contract, the Parties shall make every effort to resolve such dispute or difference amicably, by mutual consultation.

Delete Clause 27.2 in its entirety and replace with the following:

27.2 Should the Parties fail to resolve any dispute by way of mutual consultation, either party shall be entitled to refer the matter for mediation before an independent and impartial person appointed by the City Manager in accordance with Regulation 50(1) of the Local Government: Municipal Finance Management Act, 56 of 2003 – Municipal Supply Chain Management Regulations (Notice 868 of 2005). Such referral shall be done by either party giving written notice to the other of its intention to commence with mediation. No mediation may be commenced unless such notice is given to the other party.

Irrespective whether the mediation resolves the dispute, the Parties shall bear their own costs concerning the mediation and share the costs of the mediator and related costs equally.

The mediator shall agree the procedures, representation and dates for the mediation process with the Parties. The mediator may meet the Parties together or individually to enable a settlement.

Where the Parties reach settlement of the dispute or any part thereof, the mediator shall record such agreement and on signing thereof by the Parties the agreement shall be final and binding.

Save for reference to any portion of any settlement or decision which has been agreed to be final and binding on the Parties, no reference shall be made by or on behalf of either party in any subsequent court proceedings, to any outcome of an amicable settlement by mutual consultation, or the fact that any particular evidence was given, or to any submission, statement or admission made in the course of amicable settlement by mutual consultation or mediation.

28. Limitation of Liability

Delete clause 28.1 (a) and (b) and replace with the following:

(a) notwithstanding any provision to the contrary contained in this contract, neither the supplier nor any of its officers, directors, employees, agents contractors, consultants or other representatives shall be liable to the purchaser, whether in contract, tort, or otherwise, for any indirect, incidental, special or consequential loss or damage of any kind, including without limitation the loss of use, loss of production, or loss of profits or interest costs, loss of goodwill, lost or damaged data or software, costs of substitute products/services and/or loss of business or business opportunities (whether foreseeable or unforeseeable), provided that this exclusion shall not apply to any obligation of the supplier to pay penalties and/or damages to the purchaser;

(b) the aggregate liability of the Supplier to the Purchaser, whether under the Contract, in tort or otherwise, shall not exceed the sums insured in terms of clause 11 in respect of insurable events, or where no such amounts are stated, to an amount equal to twice the Contract price, provided

that this limitation shall not apply to the cost of repairing or replacing defective equipment.

Add the following after clause 28.1:

28.2 Without detracting from, and in addition to, any of the other indemnities in this Contract, the Supplier shall be solely liable for and hereby indemnifies and holds harmless the Purchaser against all claims, charges, damages, costs, actions, liability, demands and/or proceedings and expense in connection with:

- a) personal injury or loss of life to any individual;
- b) loss of or damage to property;

arising from, out of, or in connection with the performance by the Supplier in terms of this Contract, save to the extent caused by the gross negligence or wilful misconduct of the Purchaser.

28.3 The Supplier and/or its employees, agents, concessionaires, suppliers, sub-contractors or customers shall not have any claim of any nature against the purchaser for any loss, damage, injury or death which any of them may directly or indirectly suffer, whether or not such loss, damages, injury or death is caused through negligence of the Purchaser or its agents or employees.

28.4 Notwithstanding anything to the contrary contained in this Contract, under no circumstances whatsoever, including as a result of its negligent (including grossly negligent) acts or omissions or those of its servants, agents or contractors or other persons for whom in law it may be liable, shall any party or its servants (in whose favour this constitutes a *stipulatio alteri*) be liable for any indirect, extrinsic, special, penal, punitive, exemplary or consequential loss or damage of any kind whatsoever, whether or not the loss was actually foreseen or reasonably foreseeable), sustained by the other party, its directors and/or servants, including but not limited to any loss of profits, loss of operation time, corruption or loss of information and/or loss of contracts.

28.5 Each party agrees to waive all claims against the other insofar as the aggregate of compensation which might otherwise be payable exceeds the aforesaid maximum amounts payable.

31. Notices

Delete clauses 31.1 and 31.2 and replace with the following:

31.1 Any notice, request, consent, approvals or other communications made between the Parties pursuant to the Contract shall be in writing and forwarded to the addresses specified in the Contract and may be given as set out hereunder and shall be deemed to have been received when:

- a) hand delivered – on the day delivery of delivery or the next Working Day,
- b) sent by registered mail – five (5) Working Days after mailing,
- c) sent by email or telefax – one (1) Working Day after transmission.

32. Taxes and Duties

Delete the final sentence of 32.3 and replace with the following:

. In this regard, it is the responsibility of the Tenderer to submit evidence in the form of a valid Tax Compliance Status PIN issued by SARS to the CCT at the Supplier Management Unit located within the Supplier Management / Registration Office, 2nd Floor (Concourse Level), Civic Centre, 12 Hertzog Boulevard, Cape Town (Tel 021 400 9242/3/4/5), or included with this tender.

Add the following after clause 32.3:

32.4 The VAT registration number of the CCT is 4500193497.

ADDITIONAL CONDITIONS OF CONTRACT

Add the following Clause after Clause 34:

35. Reporting Obligations

35.1 The Supplier shall complete, sign and submit with each delivery note, all the documents as required in the Specifications including Monthly Project Labour Reports (Annexure B). Any failure in this regard may result in a delay in the processing of payments.

36. Workshop Premises and Facilities

- 36.1 The supplier must within ninety (90) days from commencement of the contract, establish a Workshop Facility within the Geographical Boundaries of the City of Cape Town which meets the requirements set out in Specifications in full, and otherwise meets the requirements necessary for the supplier to render the services contemplated in this contract and to meet its obligations.
- 36.2 Should the supplier fail to establish a Workshop Facility which complies with the aforementioned requirements, within the ninety (90) days mentioned in clause 36.1 above or a reduced period as contemplated, this shall be a material breach of the contract and the City shall be entitled to terminate the contract forthwith and without further notice to the supplier.
- 36.3 The supplier shall submit to the City of Cape Town all documents as requested in the Specification as well as the responsive criteria mentioned in the tender document.
- 36.4 The City of Cape Town reserves the right to conduct adhoc inspections of the tenderers IN-CONTRACT activities.

C.7 GENERAL CONDITIONS OF CONTRACT

(National Treasury - General Conditions of Contract (revised July 2010))

TABLE OF CLAUSES

1. Definitions
2. Application
3. General
4. Standards
5. Use of contract documents and information; inspection
6. Patent rights
7. Performance security
8. Inspections, tests and analysis
9. Packing
10. Delivery and documents
11. Insurance
12. Transportation
13. Incidental services
14. Spare parts
15. Warranty
16. Payment
17. Prices
18. Contract amendments
19. Assignment
20. Subcontracts
21. Delays in the supplier's performance
22. Penalties
23. Termination for default
24. Dumping and countervailing duties
25. Force majeure
26. Termination for insolvency
27. Settlement of disputes
28. Limitation of liability
29. Governing language
30. Applicable law
31. Notices
32. Taxes and duties
33. National Industrial Participation Programme (NIPP)
34. Prohibition of restrictive practices

1. Definitions

1. The following terms shall be interpreted as indicated:

- 1.1 'Closing time' means the date and hour specified in the bidding documents for the receipt of bids.
- 1.2 'Contract' means the written agreement entered into between the purchaser and the supplier, as recorded in the contract form signed by the Parties, including all attachments and appendices thereto and all documents incorporated by reference therein.
- 1.3 'Contract price' means the price payable to the supplier under the contract for the full and proper performance of his or her contractual obligations.
- 1.4 'Corrupt practice' means the offering, giving, receiving, or soliciting of anything of value to influence the action of a public official in the procurement process or in contract execution.
- 1.5 'Countervailing duties' are imposed in cases in which an enterprise abroad is subsidised by its government and encouraged to market its products internationally.

- 1.6 'Country of origin' means the place where the goods were mined, grown or produced or from which the services are supplied. Goods are produced when, through manufacturing, processing or substantial and major assembly of components, a commercially recognised new product results that is substantially different in basic characteristics or in purpose or utility from its components.
- 1.7 'Day' means calendar day.
- 1.8 'Delivery' means delivery in compliance with the conditions of the contract or order.
- 1.9 'Delivery ex stock' means immediate delivery directly from stock actually on hand.
- 1.10 'Delivery into consignee's store or to his site' means delivered and unloaded in the specified store or depot or on the specified site in compliance with the conditions of the contract or order, the supplier bearing all risks and charges involved until the supplies are so delivered and a valid receipt is obtained.
- 1.11 'Dumping' occurs when a private enterprise abroad markets its goods on its own initiative in the RSA at lower prices than that of the country of origin, and which action has the potential to harm the local industries in the RSA.
- 1.12 'Force majeure' means an event beyond the control of the supplier, not involving the supplier's fault or negligence, and not foreseeable. Such events may include, but are not restricted to, acts of the purchaser in its sovereign capacity, wars or revolutions, fires, floods, epidemics, quarantine restrictions and freight embargoes.
- 1.13 'Fraudulent practice' means a misrepresentation of facts in order to influence a procurement process or the execution of a contract to the detriment of any bidder, and includes collusive practice among bidders (prior to or after bid submission) designed to establish bid prices at artificial, non-competitive levels and to deprive the bidder of the benefits of free and open competition.
- 1.14 'GCC' means the General Conditions of Contract.
- 1.15 'Goods' means all of the equipment, machinery, and/or other materials that the supplier is required to supply to the purchaser under the contract.
- 1.16 'Imported content' means that portion of the bidding price represented by the cost of components, parts or materials which have been or are still to be imported (whether by the supplier or his subcontractors) and which costs are inclusive of the costs abroad, plus freight and other direct importation costs such as landing costs, dock dues, import duty, sales duty or other similar tax or duty at the South African place of entry as well as transportation and handling charges to the factory in the Republic where the supplies covered by the bid will be manufactured.
- 1.17 'Local content' means that portion of the bidding price which is not included in the imported content, provided that local manufacture does take place.
- 1.18 'Manufacture' means the production of products in a factory using labour, materials, components and machinery, and includes other, related value-adding activities.
- 1.19 'Order' means an official written order issued for the supply of goods or works or the rendering of a service.
- 1.20 'Project site', where applicable, means the place indicated in bidding documents.
- 1.21 'Purchaser' means the organisation purchasing the goods.
- 1.22 'Republic' means the Republic of South Africa.
- 1.23 'SCC' means the Special Conditions of Contract.

1.24 'Services' means those functional services ancillary to the supply of the goods, such as transportation and any other incidental services, such as installation, commissioning, provision of technical assistance, training, catering, gardening, security, maintenance, and other such obligations of the supplier covered under the contract.

1.25 'Written' or 'in writing' means handwritten in ink or any form of electronic or mechanical writing.

2. Application

2.1 These general conditions are applicable to all bids, contracts and orders, including bids for functional and professional services, sales, hiring, letting and the granting or acquiring of rights, but excluding immovable property, unless otherwise indicated in the bidding documents.

2.2 Where applicable, special conditions of contract are also laid down to cover specific supplies, services or works.

2.3 Where such special conditions of contract are in conflict with these general conditions, the special conditions shall apply.

3. General

3.1 Unless otherwise indicated in the bidding documents, the purchaser shall not be liable for any expense incurred in the preparation and submission of a bid. Where applicable, a non-refundable fee for documents may be charged.

3.2 With certain exceptions, invitations to bid are only published in the Government Tender Bulletin. The Government Tender Bulletin may be obtained directly from the Government Printer, Private Bag X85, Pretoria 0001, or accessed electronically from www.treasury.gov.za.

4. Standards

4.1 The goods supplied shall conform to the standards mentioned in the bidding documents and specifications.

5. Use of contract documents and information; inspection.

5.1 The supplier shall not, without the purchaser's prior written consent, disclose the contract, or any provision thereof, or any specification, plan, drawing, pattern, sample, or information furnished by or on behalf of the purchaser in connection therewith, to any person other than a person employed by the supplier in the performance of the contract. Disclosure to any such employed person shall be made in confidence and shall extend only as far as may be necessary for the purposes of such performance.

5.2 The supplier shall not, without the purchaser's prior written consent, make use of any document or information mentioned in GCC clause 5.1, except for purposes of performing the contract.

5.3 Any document, other than the contract itself, mentioned in GCC clause 5.1 shall remain the property of the purchaser and shall be returned (all copies) to the purchaser on completion of the supplier's performance under the contract if so required by the purchaser.

5.4 The supplier shall permit the purchaser to inspect the supplier's records relating to the performance of the supplier and to have them audited by auditors appointed by the purchaser, if so required by the purchaser.

6. Patent rights

6.1 The supplier shall indemnify the purchaser against all third-party claims of infringement of patent, trademark, or industrial design rights arising from the use of the goods or any part thereof by the purchaser.

7. Performance Security

7.1 Within 30 (thirty) days of receipt of the notification of contract award, the successful bidder shall furnish to the purchaser the performance security of the amount specified in the SCC.

- 7.2 The proceeds of the performance security shall be payable to the purchaser as compensation for any loss resulting from the supplier's failure to complete his obligations under the contract.
- 7.3 The performance security shall be denominated in the currency of the contract or in a freely convertible currency acceptable to the purchaser, and shall be in one of the following forms:
- a) a bank guarantee or an irrevocable letter of credit issued by a reputable bank located in the purchaser's country or abroad, acceptable to the purchaser, in the form provided in the bidding documents or another form acceptable to the purchaser; or
 - b) A cashier's or certified cheque.
- 7.4 The performance security will be discharged by the purchaser and returned to the supplier not later than 30 (thirty) days following the date of completion of the supplier's performance obligations under the contract, including any warranty obligations, unless otherwise specified in the SCC.

8. Inspections, tests and analyses

- 8.1 All pre-bidding testing will be for the account of the bidder.
- 8.2 If it is a bid condition that supplies to be produced or services to be rendered should at any stage during production or execution or on completion be subject to inspection, the premises of the bidder or contractor shall be open, at all reasonable hours, for inspection by a representative of the Department or an organisation acting on behalf of the Department.
- 8.3 If there are no inspection requirements indicated in the bidding documents and no mention of such is made in the contract, but during the contract period it is decided that inspections shall be carried out, the purchaser shall itself make the necessary arrangements, including payment arrangements with the testing authority concerned.
- 8.4 If the inspections, tests and analyses referred to in clauses 8.2 and 8.3 show the supplies to be in accordance with the contract requirements, the cost of the inspections, tests and analyses shall be defrayed by the purchaser.
- 8.5 Where the supplies or services referred to in clauses 8.2 and 8.3 do not comply with the contract requirements, irrespective of whether such supplies or services are accepted or not, the cost in connection with these inspections, tests or analyses shall be defrayed by the supplier.
- 8.6 Supplies and services which are referred to in clauses 8.2 and 8.3 and which do not comply with the contract requirements may be rejected.
- 8.7 Any contract supplies may on or after delivery be inspected, tested or analysed and may be rejected if found not to comply with the requirements of the contract. Such rejected supplies shall be held at the cost and risk of the supplier, who shall, when called upon, remove them immediately at his own cost and forthwith substitute them with supplies which do comply with the requirements of the contract. Failing such removal, the rejected supplies shall be returned at the suppliers cost and risk. Should the supplier fail to provide the substitute supplies forthwith, the purchaser may, without giving the supplier further opportunity to substitute the rejected supplies, purchase such supplies as may be necessary at the expense of the supplier.
- 8.8 The provisions of clauses 8.4 to 8.7 shall not prejudice the right of the purchaser to cancel the contract on account of a breach of the conditions thereof, or to act in terms of Clause 23 of the GCC.

9. Packing

- 9.1 The supplier shall provide such packing of the goods as is required to prevent their damage or deterioration during transit to their final destination, as indicated in the contract. The packing shall be sufficient to withstand, without limitation, rough handling during transit and exposure to extreme temperatures, salt and precipitation during transit, and open storage. Packing, case size and weights shall take into consideration, where appropriate, the remoteness of the goods' final destination and the absence of heavy handling facilities at all points in transit.
- 9.2 The packing, marking, and documentation within and outside the packages shall comply strictly with such special requirements as shall be expressly provided for in the contract, including additional requirements, if any, specified in the SCC, and in any subsequent instructions ordered by the purchaser.

10. Delivery and documents

10.1 Delivery of the goods shall be made by the supplier in accordance with the terms specified in the contract. The details of shipping and/or other documents to be furnished by the supplier are specified in the SCC.

10.2 Documents to be submitted by the supplier are specified in the SCC.

11. Insurance

11.1 The goods supplied under the contract shall be fully insured, in a freely convertible currency, against loss or damage incidental to manufacture or acquisition, transportation, storage and delivery in the manner specified in the SCC.

12. Transportation

12.1 Should a price other than an all-inclusive delivered price be required, this shall be specified in the SCC.

13. Incidental Services

13.1 The supplier may be required to provide any or all of the following services, including additional services (if any) specified in the SCC:

- (a) performance or supervision of on-site assembly, and/or commissioning of the supplied goods;
- (b) furnishing of tools required for the assembly and/or maintenance of the supplied goods;
- (c) furnishing of a detailed operations and maintenance manual for each appropriate unit of the supplied goods;
- (d) performance or supervision or maintenance and/or repair of the supplied goods, for a period of time agreed by the Parties, provided that this service shall not relieve the supplier of any warranty obligations under this contract; and
- (e) training of the purchaser's personnel, at the supplier's plant and/or on-site, in assembly, start-up, operation, maintenance, and/or repair of the supplied goods.

13.2 Prices charged by the supplier for incidental services, if not included in the contract price for the goods, shall be agreed upon in advance by the Parties and shall not exceed the prevailing rates charged to other Parties by the supplier for similar services.

14. Spare parts

14.1 As specified in the SCC, the supplier may be required to provide any or all of the following materials, notifications, and information pertaining to spare parts manufactured or distributed by the supplier:

- (a) such spare parts as the purchaser may elect to purchase from the supplier, provided that this election shall not relieve the supplier of any warranty obligations under the contract; and
- (b) in the event of termination of production of the spare parts:
 - (i) Advance notification to the purchaser of the pending termination, in sufficient time to permit the purchaser to procure needed requirements; and
 - (ii) following such termination, furnishing at no cost to the purchaser, the blueprints, drawings, and specifications of the spare parts, if requested.

15. Warranty

15.1 The supplier warrants that the goods supplied under the contract are new, unused, of the most recent or current models, and that they incorporate all recent improvements in design and materials unless provided otherwise in the contract. The supplier further warrants that all goods supplied under this contract shall have no defect arising from design, materials, or workmanship (except when the design and/or material is required by the purchaser's specifications), or from any act or omission of the supplier, that may develop under normal use of the supplied goods in the conditions prevailing in the country of final destination.

15.2 This warranty shall remain valid for 12 (twelve) months after the goods, or any portion thereof, as the case may be, have been delivered to and accepted at the final destination indicated in the contract, or for 18 (eighteen) months after the date of shipment from the port or place of loading in the source country, whichever period concludes earlier, unless specified otherwise in the SCC.

15.3 The purchaser shall notify the supplier promptly, in writing, of any claims arising under this warranty.

15.4 Upon receipt of such notice, the supplier shall, within the period specified in the SCC and with all reasonable speed, repair or replace the defective goods or parts thereof, without costs to the purchaser.

15.5 If the supplier, having been notified, fails to remedy the defect(s) within the period specified in the SCC, the purchaser may proceed to take such remedial action as may be necessary, at the supplier's risk and expense and without prejudice to any other rights which the purchaser may have against the supplier under the contract.

16. Payment

16.1 The method and conditions of payment to be made to the supplier under this contract shall be specified in the SCC.

16.2 The supplier shall furnish the purchaser with an invoice accompanied by a copy of the delivery note and upon fulfilment of any other obligations stipulated in the contract.

16.3 Payments shall be made promptly by the purchaser, but in no case later than 30 (thirty) days after submission of an invoice or claim by the supplier.

16.4 Payment will be made in Rand unless otherwise stipulated in the SCC.

17. Prices

17.1 Prices charged by the supplier for goods delivered and services performed under the contract shall not vary from the prices tendered by the supplier in his bid, with the exception of any price adjustments authorized in the SCC or in the purchaser's request for bid validity extension, as the case may be.

18. Contract Amendments

18.1 No variation in or modification of the terms of the contract shall be made except by written amendment signed by the Parties concerned.

19. Assignment

19.1 The supplier shall not assign, in whole or in part, its obligations to perform under the contract, except with the purchaser's prior written consent.

20. Subcontracts

20.1 The supplier shall notify the purchaser in writing of all subcontracts awarded under this contract if not already specified in the bid. Such notification, in the original bid or later, shall not relieve the supplier from any liability or obligation under the contract.

21. Delays in the supplier's performance

21.1 Delivery of the goods and performance of services shall be made by the supplier in accordance with the time schedule prescribed by the purchaser in the contract.

21.2 If at any time during the performance of the contract, the supplier or its subcontractor(s) should encounter conditions impeding timely delivery of the goods and performance of services, the supplier shall promptly notify the purchaser in writing of the fact of the delay, its likely duration and its cause(s). As soon as practicable after receipt of the supplier's notice, the purchaser shall evaluate the situation and may at his or her discretion extend the supplier's time for performance, with or without the imposition of penalties, in which case the extension shall be ratified by the Parties by amendment of contract.

21.3 No provision in a contract shall be deemed to prohibit the obtaining of supplies or services from a national department, provincial department, or a local authority.

21.4 The right is reserved to procure, outside of the contract, small quantities of supplies; or to have minor essential services executed if an emergency arises, or the supplier's point of supply is not situated at or near the place where the supplies are required, or the supplier's services are not readily available.

- 21.5 Except as provided under GCC Clause 25, a delay by the supplier in the performance of its delivery obligations shall render the supplier liable to the imposition of penalties, pursuant to GCC Clause 22, unless an extension of time is agreed upon pursuant to GCC Clause 21.2 without the application of penalties.
- 21.6 Upon any delay beyond the delivery period in the case of a supplies contract, the purchaser shall, without cancelling the contract, be entitled to purchase supplies of a similar quality and up to the same quantity in substitution of the goods not supplied in conformity with the contract and to return any goods delivered later at the supplier's expense and risk, or to cancel the contract and buy such goods as may be required to complete the contract and, without prejudice to his other rights, be entitled to claim damages from the supplier.

22. Penalties

- 22.1 Subject to GCC Clause 25, if the supplier fails to deliver any or all of the goods or to perform the services within the period(s) specified in the contract, the purchaser shall, without prejudice to its other remedies under the contract, deduct from the contract price, as a penalty, a sum calculated on the delivered price of the delayed goods or unperformed services, using the current prime interest rate, calculated for each day of the delay until actual delivery or performance. The purchaser may also consider termination of the contract pursuant to GCC Clause 23.

23. Termination for default

- 23.1 The purchaser, without prejudice to any other remedy for breach of contract, by written notice of default sent to the supplier, may terminate this contract in whole or in part:
- (a) if the supplier fails to deliver any or all of the goods within the period(s) specified in the contract, or within any extension thereof granted by the purchaser pursuant to GCC Clause 21.2;
 - (b) if the supplier fails to perform any other obligation(s) under the contract; or
 - (c) if the supplier, in the judgment of the purchaser, has engaged in corrupt or fraudulent practices in competing for or in executing the contract.
- 23.2 In the event the purchaser terminates the contract in whole or in part, the purchaser may procure, upon such terms and in such manner as it deems appropriate, goods, works or services similar to those undelivered, and the supplier shall be liable to the purchaser for any excess costs for such similar goods, works or services. However, the supplier shall continue performance of the contract to the extent not terminated.
- 23.3 Where the purchaser terminates the contract in whole or in part, the purchaser may decide to impose a restriction penalty on the supplier by prohibiting such supplier from doing business with the public sector for a period not exceeding 10 years.
- 23.4 If a purchaser intends imposing a restriction on a supplier or any person associated with the supplier, the supplier will be allowed a time period of not more than 14 (fourteen) days to provide reasons why the envisaged restriction should not be imposed. Should the supplier fail to respond within the stipulated 14 (fourteen) days the purchaser may regard the intended penalty as not objected against and may impose it on the supplier.
- 23.5 Any restriction imposed on any person by the Accounting Officer/Authority will, at the discretion of the Accounting Officer/Authority, also be applicable to any other enterprise or any partner, manager, director or other person who wholly or partly exercises or exercised or may exercise control over the enterprise of the first-mentioned person, and with which enterprise or person the first-mentioned person is or was, in the opinion of the Accounting Officer/Authority, actively associated.
- 23.6 If a restriction is imposed, the purchaser must, within 5 (five) working days of such imposition, furnish the National Treasury with the following information:
- (i) the name and address of the supplier and/or person restricted by the purchaser;
 - (ii) the date of commencement of the restriction;
 - (iii) the period of restriction; and
 - (iv) the reasons for the restriction.

These details will be loaded in the National Treasury's central database of suppliers or persons prohibited from doing business with the public sector.

23.7 If a court of law convicts a person of an offence as contemplated in sections 12 or 13 of the Prevention and Combating of Corrupt Activities Act, Act 12 of 2004, the court may also rule that such person's name be endorsed on the Register for Tender Defaulters. When a person's name has been endorsed on the Register, the person will be prohibited from doing business with the public sector for a period of not less than five years and not more than 10 years. The National Treasury is empowered to determine the period of restriction, and each case will be dealt with on its own merits. According to section 32 of the Act the Register must be open to the public. The Register can be perused on the National Treasury website.

24. Anti-dumping and countervailing duties and rights

24.1 When, after the date of bid, provisional payments are required, or anti-dumping or countervailing duties are imposed, or the amount of a provisional payment or anti-dumping or countervailing right is increased in respect of any dumped or subsidised import, the State is not liable for any amount so required or imposed, or for the amount of any such increase. When, after the said date, such a provisional payment is no longer required or any such anti-dumping or countervailing right is abolished, or where the amount of such provisional payment or any such right is reduced, any such favourable difference shall, on demand, be paid forthwith by the contractor to the State, or the State may deduct such amounts from moneys (if any) which may otherwise be due to the contractor in regard to supplies or services which he or she delivered or rendered, or is to deliver or render in terms of the contract or any other contract or any other amount which may be due to him or her.

25. Force majeure

25.1 Notwithstanding the provisions of GCC Clauses 22 and 23, the supplier shall not be liable for forfeiture of its performance security, damages, or termination for default if, and to the extent that, his delay in performance or other failure to perform his obligations under the contract is the result of an event of force majeure.

25.2 If a force majeure situation arises, the supplier shall notify the purchaser promptly, in writing, of such condition and the cause thereof. Unless otherwise directed by the purchaser in writing, the supplier shall continue to perform its obligations under the contract as far as is reasonably practical, and shall seek all reasonable alternative means for performance not prevented by the force majeure event.

26. Termination for insolvency

26.1 The purchaser may at any time terminate the contract by giving written notice to the supplier if the supplier becomes bankrupt or otherwise insolvent. In this event, termination will be without compensation to the supplier, provided that such termination will not prejudice or affect any right of action or remedy which has accrued or will accrue thereafter to the purchaser.

27. Settlement of Disputes

27.1 If any dispute or difference of any kind whatsoever arises between the purchaser and the supplier in connection with or arising out of the contract, the Parties shall make every effort to resolve such dispute or difference amicably, by mutual consultation.

27.2 If, after 30 (thirty) days, the Parties have failed to resolve their dispute or difference by such mutual consultation, then either the purchaser or the supplier may give notice to the other party of his intention to commence with mediation. No mediation in respect of this matter may be commenced unless such notice is given to the other party.

27.3 Should it not be possible to settle a dispute by means of mediation, it may be settled in a South African court of law.

27.4 Mediation proceedings shall be conducted in accordance with the rules of procedure specified in the SCC.

27.5 Notwithstanding any reference to mediation and/or court proceedings herein,

- (a) the Parties shall continue to perform their respective obligations under the contract unless they otherwise agree; and
- (b) the purchaser shall pay the supplier any monies due to the supplier.

28. Limitation of Liability

28.1 Except in cases of criminal negligence or wilful misconduct, and in the case of infringement pursuant to Clause 6:

- (a) the supplier shall not be liable to the purchaser, whether in contract, tort, or otherwise, for any indirect or consequential loss or damage, loss of use, loss of production, or loss of profits or interest costs, provided that this exclusion shall not apply to any obligation of the supplier to pay penalties and/or damages to the purchaser; and
- (b) the aggregate liability of the supplier to the purchaser, whether under the contract, in tort or otherwise, shall not exceed the total contract price, provided that this limitation shall not apply to the cost of repairing or replacing defective equipment.

29. Governing language

29.1 The contract shall be written in English. All correspondence and other documents pertaining to the contract that is exchanged by the Parties shall also be written in English.

30. Applicable Law

30.1 The contract shall be interpreted in accordance with South African laws, unless otherwise specified in the SCC.

31. Notices

31.1 Every written acceptance of a bid shall be posted to the supplier concerned by registered or certified mail, and any other notice to him shall be posted by ordinary mail, to the address furnished in his bid or to the address notified later by him in writing; and such posting shall be deemed to be proper service of such notice.

31.2 The time mentioned in the contract documents for performing any act after such aforesaid notice has been given, shall be reckoned from the date of posting of such notice.

32. Taxes and Duties

32.1 A foreign supplier shall be entirely responsible for all taxes, stamp duties, licence fees, and other such levies imposed outside the purchaser's country.

32.2 A local supplier shall be entirely responsible for all taxes, duties, licence fees, etc., incurred until delivery of the contracted goods to the purchaser.

32.3 No contract shall be concluded with any bidder whose tax matters are not in order. Prior to the award of a bid the Department must be in possession of a tax clearance certificate submitted by the bidder. This certificate must be an original issued by the South African Revenue Services.

33. National Industrial Participation (NIP) Programme

33.1 The NIP Programme administered by the Department of Trade and Industry shall be applicable to all contracts that are subject to the NIP obligation.

34 Prohibition of Restrictive practices

34.1 In terms of section 4 (1) (b) (iii) of the Competition Act, Act 89 of 1998, as amended, an agreement between or concerted practice by firms, or a decision by an association of firms, is prohibited if it is between Parties in a horizontal relationship and if a bidder(s) is/are or a contractor(s) was/were involved in collusive bidding (or bid rigging).

34.2 If a bidder(s) or contractor(s), based on reasonable grounds or evidence obtained by the purchaser, has/have engaged in the restrictive practice referred to above, the purchaser may refer the matter to the Competition Commission for investigation and possible imposition of administrative penalties as contemplated in the Competition Act, Act 89 of 1998.

34.3 If a bidder(s) or contractor(s) has/have been found guilty by the Competition Commission of the restrictive practice referred to above, the purchaser may, in addition and without prejudice to any other remedy provided for, invalidate the bid(s) for such item(s) offered, and/or terminate the contract in whole or part, and/or restrict the bidder(s) or contractor(s) from conducting business with the public sector for a period not exceeding 10 (ten) years and/or claim damages from the bidder(s) or contractor(s) concerned.

C.8 ANNEXURES

Annexure A – Pro Forma Insurance Broker’s Warranty



Letterhead of supplier’s Insurance Broker

Date _____

CCT
City Manager
Civic Centre
12 Hertzog Boulevard
Cape Town
8000

Dear Sir

TENDER NO.: **241G/2023/24**

TENDER DESCRIPTION: **SUPPLY AND DELIVERY OF LANDFILL PLANT AND EQUIPMENT**

NAME OF SUPPLIER: _____

I, the undersigned, do hereby confirm and warrant that all the insurances required in terms of the abovementioned contract have been issued and/or in the case of blanket/umbrella policies, have been endorsed to reflect the interests of the CCT with regard to the abovementioned contract, and that all the insurances and endorsements, etc., are all in accordance with the requirements of the contract.

I furthermore confirm that all premiums in the above regard have been paid.

Yours faithfully

Signed: _____

For: _____ (Supplier’s Insurance Broker)

Annexure B – Monthly Project Labour Report

ANNEX 1

CITY OF CAPE TOWN MONTHLY PROJECT LABOUR REPORT



Instructions for completing and submitting forms

General

- 1 The Monthly Project Labour Reports must be completed in full, using typed, proper case characters; alternatively, should a computer not be available, handwritten in black ink.
- 2 Incomplete / incorrect / illegible forms will not be accepted.
- 3 Any conditions relating to targeted labour stipulated in the Contract (in the case of contracted out services or works) shall apply to the completion and submission of these forms.
- 4 This document is available in Microsoft Excel format upon request from the City's EPWP office, tel 021 400 9406, email EPWPLR@capetown.gov.za.

Project Details

- 5 If a field is not applicable insert the letters: NA
- 6 Only the Project Number supplied by the Corporate EPWP Office must be inserted. The Project Number can be obtained from the Coordinator or Project Manager or from the e-mail address in point 4 above.
- 7 On completion of the contract or works project the anticipated end date must be updated to reflect the actual end date.

Beneficiary Details and Work Information

- 8 Care must be taken to ensure that beneficiary details correspond accurately with the beneficiary's ID document.

- 9 A new beneficiary is one in respect of which a new employment contract is signed in the current month. A certified ID copy must accompany this labour report on submission.
- 10 Was the beneficiary sourced from the City's job seeker database?
- 11 The contract end date as stated in the beneficiary's employment contract.
- 12 Where a beneficiary has not worked in a particular month, the beneficiary's name shall not be reflected on this form at all for the month in question.
- 13 Training will be recorded separately from normal working days and together shall not exceed the maximum of 23 days per month
- 14 Workers earning more than the maximum daily rate (currently R450 excluding any benefits) shall not be reflected on this form at all.

Submission of Forms

- 15 Signed hardcopy forms must be scanned and submitted to the City's project manager in electronic (.pdf) format, together with the completed form in Microsoft Excel format.
- 16 Scanned copies of all applicable supporting documentation must be submitted along with each monthly project labour report. Copies of employment contracts and ID documents are only required in respect of new beneficiaries.
- 17 If a computer is not available hardcopy forms and supporting documentation will be accepted.

PROJECT DETAILS

Numbers in cells below e.g (6) refer to the relevant instruction above for completing and submitting forms

CONTRACT OR WORKS PROJECT NAME: (6)		EPWP SUPPLIED PROJECT NUMBER: (6)										
DIRECTORATE:		DEPARTMENT:										
CONTRACTOR OR VENDOR NAME:		CONTRACTOR OR VENDOR E-MAIL ADDRESS:										
CONTRACTOR OR VENDOR CONTACT PERSON:		CONTRACTOR OR VENDOR TEL. NUMBER:										
CELL WORK												
PROJECT LABOUR REPORT CURRENT MONTH (mark with "X")												
JAN	FEB	MAR	APR	MAY	JUN	JUL	AUG	SEP	OCT	NOV	DEC	YEAR
ACTUAL START DATE (yyyy/mm/dd)						ANTICIPATED / ACTUAL END DATE (yyyy/mm/dd) (7)						
TOTAL PROJECT EXPENDITURE / VALUE OF WORK DONE TO-DATE (INCLUDING ALL COSTS, BUT EXCLUDING VAT)												
R												

Annexure C - Pro Forma Performance Security/ Guarantee

NOT APPLICABLE

Annexure D - Pro Forma Advance Payment Guarantee

NOT APPLICABLE

Annexure F - Tender Returnable Documents

Schedule F.1: Contract Price Adjustment

1. TENDER CONDITIONS

- 1.1 The Contract Price Adjustment (CPA) mechanism and/or provisions relating to Rate of Exchange (RoE) Variation, contained in this schedule is compulsory and binding on all Tenderers/Suppliers and this schedule (the parts relevant to the particular tender) must be completed by all Tenderers / Suppliers.
- 1.2 Tenderers/Suppliers are not permitted to amend, vary, alter or delete this schedule or any part thereof unless otherwise stated in this schedule.
- 1.3 Tenderers are not permitted to offer fixed and firm prices except as provided for in the Price Schedule.

2. CPA PROVISIONS SELECTION

- 2.1 The prices stipulated on the Price Schedule are subject to adjustment as set out below.
- 2.2 Tenderer to indicate the specific CPA and/or RoE provisions applicable to their bid by marking the relevant checkboxes below. Tenderers to note that the CPA and/or RoE provisions are not exclusive and multiple CPA Types can exist if the bid contains both local and foreign exchange based pricing. In such cases the CPA and/or ROE provision applies only to that particular portion of the tendered price.
- 2.3 The CPA and/or RoE provisions applicable to this tender and resulting contract are to be indicated below by checking the relevant boxes (with multiple selections only where indicated permissible):

	<u>Indicate option</u> ↓	<u>CPA Type</u>	<u>Period</u>	<u>Refer to Section</u>
A	<input type="checkbox"/> N/A	FIRM PRICES as per Pricing Schedule	Annual	<i>Pricing Schedule C.4 and Schedule F.1 (A)</i>
<u>LOCAL (RSA) TENDER CONTENT:</u>				
EITHER				
B	<input type="checkbox"/> N/A	SEIFSA Index based CPA	Monthly / Quarterly	<i>Schedule F.1 (B)</i>
OR				
C	<input type="checkbox"/>	Pricelist / Quotation Based CPA	Ad-Hoc	<i>Schedule F.1 (C)</i>
OR				
D	<input type="checkbox"/>	STATS SA CPI Index Based CPA	Annually	<i>Schedule F.1 (D)</i>
OR/AND				
E	<input type="checkbox"/> N/A	Sectorial Determination 1: Contract Cleaning Sector	Annually	<i>Schedule F.1 (E)</i>
OR				
E	<input type="checkbox"/> N/A	Sectorial Determination 6: Private Security Sector	Annually	<i>Schedule F.1 (E)</i>
<u>IMPORTED GOODS AND / OR COMPONENTS (IF APPLICABLE)</u>				
F	<input type="checkbox"/>	ROE based CPA	Ad-Hoc	<i>Schedule F.1 (F)</i>
AND (IF REQUIRED), EITHER				
G	<input type="checkbox"/>	Pricelist / Quotation based CPA	Ad-Hoc / Periodic	<i>Schedule F.1 (G)</i>
OR				
H	<input type="checkbox"/>	Overseas CPI / PPI index based CPA	Ad-Hoc / Periodic	<i>Schedule F.1 (H)</i>

- 2.4 CPA and/or RoE provisions marked as **not applicable** is not relevant and will not apply to this tender and resulting contract.

3. CONTRACT CPA APPLICATIONS AND ADMINISTRATION

- 3.1 Any claim for variation in the contract price (either CPA or RoE adjustments) must be submitted in writing:
- i. By letter to: Director **Urban Waste Management : Waste Service**, City of Cape Town, P O Box 655, Cape Town, 8000 or
 - ii. By email to: Bongiwe.Madlingozi@capetown.gov.za
- at least 14 days prior** to the month upon which the adjustment would become effective in the case of prices being set in advance, and as soon as relevant indices are available and no later than 60 days after the date of delivery of goods or the completion of the project (i.e. date of issue of the Taking-Over Certificate, if applicable) in the case of adjustments being claimed retrospectively for Goods or Services. The latter case is only applicable where specifically provided for in the CPA provisions.
- 3.2 When submitting a request for CPA and/or RoE adjustment the Supplier shall indicate the Rand Value claimed for each item listed on C.4 - Price Schedule, clearly indicating the item number as per C.4 - Price Schedule. Percentage increases will not be considered. A mere notification of a request for CPA without stating the new price claimed for each item shall, for the purpose of this clause, not be regarded as a valid request.
- 3.3 The CCT reserves the right to request the Supplier to submit auditor's certificates or such other documentary proof as it may require in order to verify a claim for CPA or RoE adjustments. Price adjustments will not be processed until such time as the Supplier submits such auditor's certificates or other documentary proof to the CCT. Should the Supplier fail to submit the auditor's certificates or other documentary proof to the CCT within 30 days from the written request, it shall be presumed that the Supplier has abandoned his request.
- 3.4 The CCT reserves the right to withhold payment of any claim for adjustment while only provisional figures are available and until such time as the final (revised) figures are issued by the relevant authority.
- 3.5 The CCT will confirm in writing once processing of the CPA or RoE adjustments have been completed including the effective date of the adjustments.
- 3.6 Where pricelist-based and other non-index based CPA requests are investigated and found to be not reasonable and market related, the CCT reserves the right to reject such requests. Where disputes arise with respect to such rejected requests, the CCT reserves the right to procure the Goods from other available Suppliers until such time as the dispute is resolved.
- 3.7 Unless indicated otherwise in the relevant schedule below, the adjustment will apply to all Purchase Orders or Purchase Order lines where the delivery date is on or after the effective date of the adjustment.

F.1 (A) – FIRM PRICES

NOT APPLICABLE

F.1 (B) LOCAL SOUTH AFRICAN CONTENT – SEIFSA INDICES

NOT APPLICABLE

TABLE F.1 (B).1: SEIFSA BASE MATERIAL AND LABOUR PRICES
--

NOT APPLICABLE

TABLE F.1 (B). (Cont'd): SEIFSA BASE MATERIAL AND LABOUR PRICES

NOT APPLICABLE

F.1 (C) LOCAL SOUTH AFRICAN CONTENT - SUPPLIER/ MANUFACTURER PRICE LIST/QUOTATIONS

1. Tenderers /Suppliers that are not the manufacturer or original supplier of the tendered goods and whose tender prices are based on the price list/quotation of another company (manufacturer or other supplier) may apply Supplier / Manufacturer Pricelist / Quotation based CPA.
2. In such cases the Tenderer is required to submit with his tender a copy of the original Supplier / Manufacturer Pricelist / Quotation upon which his tender prices are based. Such pricelist / Quotation is required to be on the Letterhead of the Supplier / Manufacture, is to be dated, referenced and signed, and is to provide clear reference to the tender number and is required to clearly reference each item quoted to the respective Tender Item Number indicated in C.4 Price Schedule.
3. The tenderer shall further confirm the Manufacturer / supplier, Quotation date and reference number and applicable tender Items by completing Table F.1(C).1 below.

Table F.1(C).1: Price Schedule information for Manufacturers/Suppliers Price List(s)/Quotation

Manufacturer/ Supplier Name	Price List Information		
	Price List/Quotation Date.	Price List/Quotation Reference Number	Pricelist applicable to Items as per C.4 Price Schedule

4. During the contract period, the Tenderer (now Supplier) must submit the request for price adjustment based on increases in pricelists of manufacturers/suppliers prior to the effective date of the increase in the pricelist.
5. The effective date of any price adjustment granted will be the first day of the month following the month during which the fully substantiated application for contract price adjustment is submitted or, by agreement between the Tenderer/Supplier and the CCT, a subsequent date on which the price adjustment will become effective.
6. In instances where the Supplier's price adjustment claimed is less than entitled, the lesser price will be accepted.
7. Purchase orders placed prior to the effective date of any price increase shall be placed at the previously agreed price, not the claimed adjusted price.
8. Only the difference in source supplier / manufacturer pricelist (actual cost, not percentage) may be adjusted and under no circumstances may the Tenderer/Supplier increase their profit margin.
9. The Tenderer/Supplier shall, when submitting claims for contract price adjustment, submit all of the documentation indicated below a minimum of two weeks prior to the effective date of the contract price adjustment:
 - a) Copies of price lists upon which original tender prices were based (refer to clause 2, Table F.1(C).1 above) clearly indicating the item(s) according to C.4 Price Schedule.
 - b) The new price list (*from the same Supplier / Manufacturer as originally tendered*) on the relevant manufacturer/suppliers letterhead (with pamphlets, brochures and e-mail communication) clearly

indicating the item(s) according to C.4 Price Schedule.

- c) Detailed calculations indicating how the “adjusted” price was calculated. The calculations must be submitted in Excel, together with a signed, “PDF” version of the Excel spreadsheet. The example below – Table F.1(C).2, is what is required.
 - d) A covering letter on the Supplier’s letterhead requesting the CPA with the effective date of the claim.
10. The CCT will consider the request and either refer the request back for correction or additional information or approve the request.
 11. The CCT will assess such pricelist based CPA claims against market pricing and indices and other input pricing indicators and will only approve such claims that are confirmed to be reasonable and market related with reference to the source pricing information provided with the tender and with the CPA application
 12. Approval of the CPA request including confirmation of the effective date, will be communicated to the Supplier in writing together with a list of the approved adjusted rates. The effective date will be as per clause 3 above.
 13. The successful Tenderer/Supplier shall immediately upon notification of the commencement date of contract submit written application for approval of any adjusted unit prices for the Goods that may have been notified by the Supplier / Manufacturer of the Goods, together with the required supporting documentation. This application will be assessed in accordance with the process laid out above in order to determine approved contract prices at the commencement of the contract.
 14. Failure to submit such application within two working weeks of commencement of contract shall result in the tendered unit prices being applied for initial orders placed following commencement of the contract.
 15. In the event of a Supplier changing their Supplier / Manufacturer during the tenure of the contract, no request for price variations will be considered unless the Supplier has obtained prior approval from the City for the change of Supplier / Manufacturer. Such approval shall include technical approval by the Engineer of the goods supplied by the replacement Supplier / Manufacturer. Technical approval by the Engineer shall be a prerequisite for any change of Supplier / Manufacturer.

Table F.1(C).2 – Pro Forma Table for Adjustments in price where the Supplier is not the Manufacturer)

C.4 Price Schedule Item No.	Original Tender Price	Previous and New Price List Information				New Contract Price (Excl. VAT)	
		Manufacturer/ Supplier	Material no.	Price as per previous Manufacturer/ Supplier Price List (Excl. Vat) Price List Date:_____	Price as per new Supplier/ Manufacturer Price List (Excl. Vat) Price List Date:_____		Difference between the previous and new manufacturer Price list (C)-(B)
	(A)			(B)	(C)	(D)	(A)+(D)

**When submitting the first request for price adjustment, use the tender price as per C.4 Price Schedule.*

F.1 (D) LOCAL SOUTH AFRICAN CONTENT - STATS SA CONSUMER PRICE INDEX

1. Applicable where the Tenderer/Suppliers has indicated their tendered prices are subject to adjustment based on changes in the Statistics South Africa (STATS SA) Consumer Price Indices.
2. A minimum of 10% of the tender price as per C.4 Pricing Schedule shall be fixed and free of variation for the duration of the contract.
3. A total of 90% of the tender price as per C.4 Pricing Schedule shall be adjusted annually in accordance with clause 5 below.
4. The Contract Price(s) shall remain FIRM for the first 12 calendar months from date of Commencement Date of Contract and Suppliers are not permitted to requests CPA during this period.
5. The Contract Price(s) will thereafter be subject to adjustment annually based on the average percentage of change over 12 months as published by STATS SA: Consumer Price Index (P0141–Table B2 – CPI headline year-on-year rates) as follows:
 - 5.1 CPA applicable from the start of the 13th month to the end of the 24th month calculated as follows:
 - a) The base month for the price adjustment being three (3) calendar months prior to Commencement Date of Contract; and
 - b) The end month shall be three (3) calendar months prior to the 12th month.
 - 5.2 CPA applicable from the start of the 25th month to end of the 36th month calculated as follows:
 - a) The base month for the price adjustment shall be three (3) calendar months prior to the 13th month; and
 - b) The end month shall be three (3) calendar months prior to 24th month.
 - 5.3 The average CPI percentage will be calculated using the base month to the end month (both included) divided by the number of months. (12 months totalled/12 to achieve the average CPI)
6. 6 Subject to prior approval by the CCT delegated authority, in the event of any extension of the contract period, the CPA applicable beyond month 36th of the contract will follow the same principle in determining the base month (i.e. 3 calendar months prior to 25th month) and end date (3 calendar months prior to 36th month) as outlined above.

F.1. (E) LOCAL SOUTH AFRICAN CONTENT – SECTORIAL DETERMINATION

NOT APPLICABLE

South Africa and is not subject to adjustment in terms of variation in rate of exchange.

4. The price adjustment for variations in the cost of plant and materials imported from outside of South Africa shall be based on the information contained on the schedule titled "Price Basis for Imported Resources" (Table F.1 (F).2). The Rand value of goods and components comprising entirely or partly imported content that is inserted on the Table F.1(F).2 titled "Price Basis for Imported Resources" (column (G)) shall be the rate tendered in the Pricing Schedule C.4, and shall be the value in foreign currency (column (A)) converted to South African Rand (column (C)) by using the closing spot selling rate on the Base Date (seven calendar days before tender closing date) rounded to the second decimal place (column (B)), to which shall be added any Customs Surcharge and Customs Duty applicable at that date (columns (D) and (E)) and any South African manufactured or added content (column (F)). Any mark-up by the Tenderer or other costs not detailed above shall be entirely contained within the South African Content (Column (F)).
5. Column A of Table F.1 (F).2 shall detail the actual quotation for the imported Goods or components, and shall be substantiated by the original source quotation for such Goods or components. (Source quotation from foreign supplier/manufacturer, see Schedule F.1 (G), Table F.1 (G).1 below). No Supplier mark-up on the foreign currency value of such imported Goods or components is permissible. All Supplier mark-up shall be included in the South African content, Column F of Table F.1 (F).2 above.
6. Based on the evidence provided in Clause 5 above, the value in Rand inserted in column (C) on the schedule titled "Price Basis for Imported Resources" shall be recalculated using the forward cover rate obtained, and any increase or decrease in the Rand value defined in this clause shall be adjusted accordingly, subject to Clause 7 below.
7. The adjustments shall be calculated upon the value in foreign currency in the Supplier's forward cover contract, provided that, should this value exceed the value in foreign currency inserted in column (A) of on the schedule titled "Price Basis for Imported Resources", then the value in column (A) shall be used (or any adjusted value approved in accordance with Schedule F.1 (G) below).
8. Any increase or decrease in the Rand value between the amounts of Customs Surcharge and Customs Duty inserted in on the schedule titled "Price Basis for Imported Resources" and those amounts actually paid to the Customs and Excise Authorities, which are due to changes in the percentage rates applicable or to the foreign exchange rate used by the authorities, shall be adjusted accordingly.
9. The Tenderer shall state the Customs Duty Tariff Reference applicable to each item and the Supplier shall advise the CCT's Agent of any changes which occur.
10. Suppliers shall take out Forward Cover covering the foreign exchange component of the cost of any imported portion of the Goods ordered on each purchase order issued by the Employer.
11. The process to be followed by Suppliers for claims for Rate of Exchange Variations shall be as follows:
 - a) The Supplier shall within seven working days from the date of receipt of the purchase order arrange for cover or recovering forward by way of a contract with a bank which is an authorised foreign exchange dealer, the foreign exchange component of the cost of any imported goods and components inserted by the Tenderer on the scheduled titled "Price Basis for Imported Resources" (Table F.1 (F).2), and submit such Forward Cover quotation to the City for approval.
 - b) Upon receipt of the quotation for Forward Cover from the bank, the Supplier must forward the quote ideally, within 15 minutes of receiving it from their banker to the CCT: CPA.Request@capetown.gov.za and Contract Manager: Bongiwe.Madlingozi@capetown.gov.za. This is to ensure that the time difference from generation of the quotation for Forward Cover to finalising the Forward Cover with the Bank, is kept to a minimum due to the change in the exchange rate throughout the day.
 - c) The Contract Manager will forward the quotation to the CCT Treasury Department immediately for their consideration and approval. The cut-off time for receipt of quotations for Forward Cover will be 14h00. It must be noted that if this deadline will not be achieved, it is recommended that the quotation process be undertaken on the following day which should fall within the 7 days of receipt of the purchase order.
 - d) Only once the Forward Cover quotation rate has been approved by CCT Treasury Department, may the Supplier finalise the Forward Cover contract with their bank at the rate approved by the CCT Treasury Department for that Purchase Order and forward a copy of the contract to the CCT via

email: CPA.Request@capetown.gov.za
Bongiwe.Madlingozi@capetown.gov.za.

and

Contract

Manager:

- e) The Forward Cover quotation envisaged above shall have the CCT purchase order number and a Forward Cover Contract (FCC) Value Date that is directly based upon the required delivery date for the imported Goods or components necessary in order to meet the Contract Delivery Period. Future FCC Value Dates beyond the Contract Delivery Period shall not be acceptable.
12. On delivery of the goods to the City the Supplier shall submit the following documentation to the CCT via email: CPA.Request@capetown.gov.za and Contract Manager: Bongiwe.Madlingozi@capetown.gov.za:
- a) The Bill of Lading/Waybill/Customs Invoice (clearly indicating the items as identified on the purchase order).
 - b) Calculations detailing the difference in the rate of exchange at the time of entry and the date of tender. These shall be submitted on a covering letter.
 - c) The invoice / credit note for the Rate of Exchange adjustment applicable to the specific order.
13. In exceptional circumstances, and subject to the Employer's explicit approval, Rate of Exchange variations on Goods or components that are imported in bulk in advance in fulfilment of the contract requirements or to create buffer stocks, but not specifically in response to specific purchase orders placed by the Employer in accordance with the contract, shall be based upon whichever of the following two methodologies is more advantageous to the Employer:
- a) Methodology 1: A spot quotation for the Forward Cover Contract rate for the imported portion of the Goods, based upon the FCC Value Date for the particular purchase order(s), as outlined in clause 11 above.
 - b) Methodology 2: The actual Rate of Exchange cost variations incurred in fulfilment of the purchase order(s), fully substantiated by detailed Bills of Lading and Customs Invoice applicable to the particular Goods delivered. The applicable Rate of Exchange shall be the rate as defined on the Customs Invoice for the imported Goods.
 - c) Determination of the more advantageous methodology shall be conducted and approved following delivery of the imported Goods or components to the Supplier but prior to delivery of the Goods to the Employer.
14. Approval of the process detailed in Clause 13 and sub-clauses above shall be on an order by order basis and application shall be submitted, with required supporting documents, immediately on receipt of the relevant purchase order(s).

**F.1. (G) GOODS AND/OR COMPONENTS IMPORTED FROM OUTSIDE OF SOUTH AFRICA -
MANUFACTURER/SUPPLIER PRICE/QUOTATION LIST**
1. Manufacturer's / Supplier's Pricelist / Quotation Based CPA – Imported Goods or Components:

- 1.1 Tenderers with imported Goods or Components may claim contract price adjustment based on the overseas SUPPLIER'S / MANUFACTURER'S PRICE LISTS/ QUOTATION from the supplier or manufacturer of the tendered items.
- 1.2 In such cases the Tenderer is required to submit with his tender a copy of the original overseas Supplier / Manufacturer Pricelist / Quotation upon which his tender prices are based. Such pricelist / Quotation is required to be on the Letterhead of the Supplier / Manufacture, is to be dated, referenced and signed, and is to provide clear reference to the tender number or unambiguously indicate the relevant component.
- 1.3 The Tenderer is required to clearly reference each item quoted to the respective Tender Item Number indicated in C.4 Price Schedule by completing Table F.1 (G).1 below.

Table F.1 (G).1: Price Schedule information for Imported Goods or Components - Manufacturers/Suppliers Price List(s)/Quotation

Manufacturer/ Supplier Name	Price List Information		
	Price List/Quotation Date.	Price List/Quotation Reference Number	Pricelist applicable to Items as per C.4 Price Schedule

- 1.4 During the contract period, the Tenderer (now Supplier) must submit the request for price adjustment based on increases in pricelists of manufacturers/suppliers prior to the effective date of the increase in the pricelist.
- 1.5 The effective date of any price adjustment granted will be the first day of the month following the month during which the fully substantiated application for contract price adjustment is submitted or, by agreement between the Tenderer/Supplier and the CCT, a subsequent date on which the price adjustment will become effective.
- 1.6 In instances where the Supplier's price adjustment claimed is less than entitled, the lesser price will be accepted.
- 1.7 Only the difference in source supplier / manufacturer pricelist (actual cost, not percentage) may be adjusted and under no circumstances may the Tenderer/Supplier increase their profit margin.
- 1.8 The Tenderer/Supplier shall, when submitting claims for contract price adjustment, submit all of the documentation indicated below a minimum of two weeks prior to the effective date of the contract price adjustment:
- a) Copies of price lists upon which original tender prices were based (refer to Clause 1.2, Table F.1 (G).1 above) clearly indicating the item(s) according to C.4 Price Schedule.
 - b) The new price list (*from the same Supplier / Manufacturer as originally tendered*) on the relevant manufacturer/suppliers letterhead (with pamphlets, brochures and e-mail communication) clearly

indicating the item(s) according to C.4 Price Schedule.

- c) Submit detailed calculations indicating how the “new” price is calculated. The calculations must be submitted in Excel, together with a signed, “PDF” version of the Excel spreadsheet. The example below – Table F.1(G).2, is what is required.
 - d) A covering letter on the Supplier’s letterhead requesting the CPA with the effective date of the claim.
- 1.9 The CCT will consider the request and either refer the request back for correction or additional information or approve the request.
- 1.10 The CCT will assess such pricelist based CPA claims and will only approve such claims that are confirmed to be reasonable and market related with reference to the source pricing information provided with the tender and with the CPA application
- 1.11 Approval of the CPA request including confirmation of the effective date, will be communicated to the Supplier in writing. The effective date will be as per clause 1.3 above.
- 1.12 The successful Tenderer/Supplier shall immediately upon notification of the commencement date of contract submit written application for approval of any adjusted unit prices for the Goods that may have been notified by the Supplier / Manufacturer of the Goods, together with the required supporting documentation. This application will be assessed in accordance with the process laid out above in order to determine approved contract prices at the commencement of the contract.
- 1.13 Failure to submit such application within two working weeks of commencement of contract shall result in the tendered unit prices being applied for initial orders placed following commencement of the contract.
- 1.14 In the event of a Supplier changing their Supplier / Manufacturer during the tenure of the contract, no request for price variations will be considered unless the Supplier has obtained prior approval from the City for the change of Supplier / Manufacturer. Such approval shall include technical approval by the Engineer of the goods supplied by the replacement Supplier / Manufacturer. Technical approval by the Engineer shall be a prerequisite for any change of Supplier / Manufacturer.

Table F.1(G).2 – Pro Forma Table for Adjustments in price for Imported Goods or Components - Manufacturers/Suppliers Price List(s)/Quotation

C.4 Price Schedule Item No.	Original Tender Price	Previous and New Price List Information					New Contract Price (Excl. VAT)
		Manufacturer/Supplier	Material no.	Price as per previous Manufacturer/Supplier Price List (Excl. Vat) Price List Date: _____ (B)	Price as per new Supplier/Manufacturer Price List (Excl. Vat) Price List Date: _____ (C)	Difference between the previous and new manufacturer Price list (C)-(B) (D)	
	(A)						(A)+(D)

OR

2. Supplier Price List Variations for Suppliers Supplying Goods Imported by Another Party

- 2.1 The Tenderers (now Supplier) that are not the director importer of the manufactured goods/components, and intend to purchase the goods from another supplier who in turn is importing the goods, may apply for Supplier / Manufacturer Pricelist / Quotation based CPA imported by a another Party.
- 2.2 In such cases the Tenderer is required to submit with his tender a copy of the original Supplier / Manufacturer Pricelist / Quotation upon which his tender prices are based. Such pricelist / Quotation is required to be on the Letterhead of the Supplier / Manufacture, is to be dated, referenced and signed, and is to provide clear reference to the tender number, exchange rate on which the quote is based and is required to clearly reference each item quoted to the respective Tender Item Number indicated in C.4 Price Schedule.
- 2.3 The tenderer shall further confirm the Manufacturer / supplier, Quotation date, exchange rate at date of quote and reference number and applicable tender Items by completing Table F.1(G).3 below.

Table F.1 (G).3: Price Schedule information for Imported Goods or Components, imported by Another Party Manufacturers/Suppliers Price List(s)/Quotation

Manufacturer/ Supplier Name	Price List Information			Pricelist applicable to Items as per C.4 Price Schedule
	Price List/Quotation Date.	Price List/Quotation Reference Number	Exchange Rate on which quote is based	
			_____ 1 : Rand _____	
			_____ 1 : Rand _____	
			_____ 1 : Rand _____	
			_____ 1 : Rand _____	

- 2.4 During the contract period, the Tenderer (now Supplier) must submit the request for price adjustment based on increases in pricelists of manufacturers/suppliers within seven calendar days of the date of the purchase order date.
- 2.5 The price adjustment claim will be fully substantiated and the approval will be limited to the relevant Purchase Order.
- 2.6 In instances where the Supplier's price adjustment claimed is less than entitled, the lesser price will be accepted.
- 2.7 Only the difference in source supplier / manufacturer pricelist (actual cost, not percentage) may be adjusted and under no circumstances may the Tenderer/Supplier increase their profit margin.
- 2.8 The Tenderer/Supplier shall, when submitting claims for contract price adjustment, submit all of the documentation indicated below a minimum of seven (7) days from date of purchase order:
 - a) Copies of price lists upon which original tender prices were based (refer to Clause 2.2, Table 2 above) clearly indicating the item(s) according to C.4 Price Schedule.
 - b) The new price list (*from the same Supplier / Manufacturer as originally tendered*) on the relevant manufacturer/suppliers letterhead (with pamphlets, brochures and e-mail communication) clearly indicating the item(s) according to C.4 Price Schedule.

- c) Submit detailed calculations indicating how the “new” price is calculated.
 - d) A covering letter on the Supplier’s letterhead requesting the CPA with the effective date of the claim.
- 2.9 The CCT will consider the request and either refer the request back for correction or additional information or approve the request.
- 2.10 The CCT will assess such pricelist based CPA claims and will only approve such claims that are confirmed to be reasonable and market related with reference to the source pricing information provided with the tender and with the CPA application
- 2.11 Approval of the CPA request for the relevant Purchase Order (refer to clause 2.5 above), will be communicated to the Supplier in writing.

F.1. (H) GOODS AND/OR COMPONENTS IMPORTED FROM OUTSIDE OF SOUTH AFRICA - BASED ON FOREIGN INDICES

1. Adjustment for variation in labour and material Costs based on Indices in the country of manufacture.

1.1 If the prices for imported Goods and/or components are not fixed, the Supplier shall in their Tender specify the formula for calculating Contract Price Adjustments normally used in the country of manufacture and the indices and relative proportions of labour and material on which his Tender prices are based. The imported goods and or components shall be adjusted annually in accordance with clause 18.2 below.

1.2 The FOB adjustment in this CPA must be read with the values stipulated in the F.1 (F) (Column A) Schedule for Rate of Exchange.

2. Formula(e) for FOB price adjustment on goods and/or components ex-import:

Cost of goods and or components manufactured outside of South Africa and any foreign installation labour (FOB values in Table 2 titled "**Price Basis for Imported Resources**" (column (A))) will be fixed and firm except for variations in the rate of exchange and statutory obligations unless the following information is provided:

$$P = Po(0,1 + 0,9N/No)$$

Where

P = Adjusted Price

Po = Original Price

10% - Fixed

And:

No

Foreign Published Index (similar to SEIFSA CPI/PPI) in country of

Origin:

N

DETAIL: _____

3. The FOB values in Table 2 titled "**Price Basis for Imported Resources**" (column (A)), shall remain fixed and firm for the first 12 calendar months from date of Commencement Date of Contract and Suppliers are not permitted to requests CPA during this period.

4. The FOB values will thereafter be subject to adjustment annually based on the average percentage of 12 months as published in the Foreign Published Index as follows:

4.1 From the start of the 13th month to the end of the 24th month calculated as follows:

- a) The base month for the price adjustment being three (3) calendar months prior to Commencement Date of Contract; and
- b) The end month shall be three (3) calendar months prior to the 12th month.

4.2 From the start of the 25th month to end of the 36th month calculated as follows:

- a) The base month for the price adjustment shall be three (3) calendar months prior to the 13th month; and
- b) The end month shall be three (3) calendar months prior to 24th month.

5. The average percentage increase in the published index will be calculated using the base month to the end month (both included) divided by the number of months. (12 months totalled/12 to achieve the average for the Foreign Published Index)

Schedule F.2: Certificate of Authority for Partnerships/ Joint Ventures/ Consortiums

This schedule is to be completed if the tender is submitted by a partnership/joint venture/ consortium.

1. We, the undersigned, are submitting this tender offer as a partnership/ joint venture/ consortium and hereby authorize Mr/Ms _____, of the authorised entity _____, acting in the capacity of Lead Partner, to sign all documents in connection with the tender offer and any contract resulting from it on the partnership/joint venture/ consortium’s behalf.

2. By signing this schedule the partners to the partnership/joint venture/ consortium:
 - 2.1 warrant that the tender submitted is in accordance with the main business and objectives of the partnership/joint venture/ consortium;
 - 2.2 agree that the CCT shall make all payments in terms of this Contract into the following bank account of the Lead Partner:
 Account Holder: _____
 Financial Institution: _____
 Branch Code: _____
 Account No.: _____
 - 2.3 agree that in the event that there is a change in the partnership/ joint venture/ consortium and/or should a dispute arise between the partnership/joint venture/ consortium partners, that the CCT shall continue to make any/all payments due and payable in terms of the Contract into the aforesaid bank account until such time as the CCT is presented with a Court Order or an original agreement (signed by each and every partner of the partnership/joint venture/ consortium) notifying the CCT of the details of the new bank account into which it is required to make payment.
 - 2.4 agree that they shall be jointly and severally liable to the CCT for the due and proper fulfilment by the successful tenderer/supplier of its obligations in terms of the Contract as well as any damages suffered by the CCT as a result of breach by the successful tenderer/supplier. The partnership/joint venture/ consortium partners hereby renounce the benefits of excussion and division.

SIGNED BY THE PARTNERS OF THE PARTNERSHIP/ JOINT VENTURE/ CONSORTIUM		
NAME OF FIRM	ADDRESS	DULY AUTHORISED SIGNATORY
Lead partner		Signature..... Name..... Designation.....
		Signature..... Name..... Designation.....
		Signature..... Name..... Designation.....
		Signature..... Name..... Designation.....

Note: A copy of the Joint Venture Agreement shall be appended to *List of Other Documents Attached by Tenderer Schedule*.

Schedule F.3: Declaration for Procurement above R10 million

If the value of the transaction is expected to exceed R10 million (VAT included) the tenderer shall complete the following questionnaire, attach the necessary documents and sign this schedule:

1. Are you by law required to prepare annual financial statements for auditing? **(Please mark with X)**

YES		NO	
-----	--	----	--

If YES, submit audited annual financial statements:

- (i) For the past three years, or
(ii) Since the date of establishment of the tenderer (if established during the past three years)

By attaching such audited financial statements to **List of Other Documents Attached by Tenderer Schedule**.

2. Do you have any outstanding undisputed commitments for municipal services towards the CCT or other municipality in respect of which payment is overdue for more than 30 (thirty) days? **(Please mark with X)**

YES		NO	
-----	--	----	--

- 2.1 If NO, this serves to certify that the tenderer has no undisputed commitments for municipal services towards any municipality for more than three (3) (three) months in respect of which payment is overdue for more than 30 (thirty) days.

- 2.2 If YES, provide particulars:

3. Has any contract been awarded to you by an organ of state during the past five (5) years? **(Please mark with X)**

YES		NO	
-----	--	----	--

If YES, insert particulars in the table below including particulars of any material non-compliance or dispute concerning the execution of such contract. Alternatively attach the particulars to **List of Other Documents Attached by Tenderer** schedule in the same format as the table below:

Organ of State	Contract Description	Contract Period	Non-compliance/dispute (if any)

4. Will any portion of the goods or services be sourced from outside the Republic, and if so, what portion and whether any portion of payment from the CCT is expected to be transferred out of the Republic? **(Please mark with X)**

YES		NO	
-----	--	----	--

If YES, furnish particulars below

The tenderer hereby certifies that the information set out in this schedule and/or attached hereto is true and correct, and acknowledges that failure to properly and truthfully complete this schedule may result in steps being taken against the tenderer, the tender being disqualified, and/or (in the event that the tenderer is successful) the cancellation of the contract, restriction of the tenderer or the exercise by the CCT of any other remedies available to it.

Signature
Print name:
On behalf of the tenderer (duly authorised)

Date

Schedule F.4: Preference Points Claim Form In Terms Of the Preferential Procurement Regulations 2022

1. GENERAL CONDITIONS

- 1.1 The following preference point systems are applicable to invitations to tender:
- the 80/20 system for requirements with a Rand value of up to R50 000 000 (all applicable taxes included); and
 - the 90/10 system for requirements with a Rand value above R50 000 000 (all applicable taxes included).

1.2 To be completed by the organ of state

The applicable preference point system for this tender is the 90/10 preference point system.

- 1.3 Points for this tender (even in the case of a tender for income-generating contracts) shall be awarded for:
- (a) Price; and
 - (b) Specific Goals.

1.4 To be completed by the organ of state:

The maximum points for this tender are allocated as follows:

	POINTS
PRICE	90
SPECIFIC GOALS	10
Total points for Price and SPECIFIC GOALS	100

- 1.5 Failure on the part of a tenderer to submit proof or documentation required in terms of this tender to claim points for specific goals with the tender, will be interpreted to mean that preference points for specific goals are not claimed.
- 1.6 The organ of state reserves the right to require of a tenderer, either before a tender is adjudicated or at any time subsequently, to substantiate any claim in regard to preferences, in any manner required by the organ of state.

2. DEFINITIONS

The following definitions shall apply to this schedule:

- (a) "tender" means a written offer in the form determined by an organ of state in response to an invitation to provide goods or services through price quotations, competitive tendering process or any other method envisaged in legislation;
- (b) "price" means an amount of money tendered for goods or services, and includes all applicable taxes less all unconditional discounts;
- (c) "rand value" means the total estimated value of a contract in Rand, calculated at the time of bid invitation, and includes all applicable taxes;
- (d) "tender for income-generating contracts" means a written offer in the form determined by an organ of state in response to an invitation for the origination of income-generating contracts through any method envisaged in legislation that will result in a legal agreement between the organ of state and a third party that produces revenue for the organ of state, and includes, but is not limited to, leasing and disposal of assets and concession contracts, excluding direct sales and disposal of assets through public auctions; and
- (e) "The Act" means the Preferential Procurement Policy Framework Act, 2000 (Act No. 5 of 2000).

3. FORMULAE FOR PROCUREMENT OF GOODS AND SERVICES**POINTS AWARDED FOR PRICE****THE 80/20 OR 90/10 PREFERENCE POINT SYSTEMS**

A maximum of 80 or 90 points is allocated for price on the following basis:

80/20 or 90/10

Or

Where

Ps = Points scored for price of tender under consideration

Pt = Price of tender under consideration

Pmin = Price of lowest acceptable tender

4. FORMULAE FOR DISPOSAL OR LEASING OF STATE ASSETS AND INCOME GENERATING PROCUREMENT**POINTS AWARDED FOR PRICE**

A maximum of 80 or 90 points is allocated for price on the following basis:

80/20 or 90/10

Or

Where:

Ps = Points scored for price of tender under consideration

Pt = Price of tender under consideration

Pmax = Price of highest acceptable tender

5. POINTS AWARDED FOR SPECIFIC GOALS

5.1 In terms of Regulation 4(2); 5(2); 6(2) and 7(2) of the Preferential Procurement Regulations, preference points must be awarded for specific goals stated in the tender. For the purposes of this tender the tenderer will be allocated points based on the goals stated in table 1 below as may be supported by proof/documentation stated in the conditions of this tender:

5.2 In cases where organs of state intend to use Regulation 3(2) of the Regulations, which states that, if it is unclear whether the 80/20 or 90/10 preference point system applies, an organ of state must, in the tender documents, stipulate in the case of—

- (a) an invitation for tender for income-generating contracts, that either the 80/20 or 90/10 preference point system will apply and that the highest acceptable tender will be used to determine the applicable preference point system; or
- (b) any other invitation for tender, that either the 80/20 or 90/10 preference point system will apply and that the lowest acceptable tender will be used to determine the applicable preference point system,

then the organ of state must indicate the points allocated for specific goals for both the 90/10 and 80/20 preference point system.

Table 1: Specific goals for the tender and points claimed are indicated per the table below.

(Note to organs of state: Where either the 90/10 or 80/20 preference point system is applicable, corresponding points must also be indicated as such.

Note to tenderers: The tenderer must indicate how they claim points for each preference point system.)

The specific goals allocated points in terms of this tender	To be Completed by the Organ of State		To be Completed by the Tenderer	
	Number of points Allocated (90/10 system)	Number of points Allocated (80/20 system)	Number of points claimed (90/10 system)	Number of points claimed (80/20 system)
Gender	3	5		N/A
Race	3	5		
Disability	1	3		
Promotion of Micro and Small Enterprises	3	7		

DECLARATION WITH REGARD TO COMPANY/FIRM

5.3 Name of company/firm.....

5.4 Company registration number:

5.5 TYPE OF COMPANY/ FIRM

- Partnership/Joint Venture / Consortium
- One-person business/sole propriety
- Close corporation
- Public Company
- Personal Liability Company
- (Pty) Limited
- Non-Profit Company
- State Owned Company

[Tick applicable box]

5.6 I, the undersigned, who is duly authorised to do so on behalf of the company/firm, certify that the points claimed, based on the specific goals as advised in the tender, qualifies the company/ firm for the preference(s) shown and I acknowledge that:

- i) The information furnished is true and correct;
- ii) The preference points claimed are in accordance with the General Conditions as indicated in paragraph 1 of this form;
- iii) In the event of a contract being awarded as a result of points claimed as shown in paragraphs 4.1 and 4.2, the Supplier may be required to furnish documentary proof to the satisfaction of the organ of state that the claims are correct;
- iv) If the specific goals have been claimed or obtained on a fraudulent basis or any of the conditions of contract have not been fulfilled, the organ of state may, in addition to any other remedy it may have –
 - (a) disqualify the person from the tendering process;
 - (b) recover costs, losses or damages it has incurred or suffered as a result of that person's conduct;
 - (c) cancel the contract and claim any damages which it has suffered as a result of having to make less favourable arrangements due to such cancellation;
 - (d) recommend that the tenderer or Supplier, its shareholders and directors, or only the shareholders and directors who acted on a fraudulent basis, be restricted from obtaining business from any organ of state for a period not exceeding 10 years, after the audi alteram partem (hear the other side) rule has been applied; and
 - (e) forward the matter for criminal prosecution, if deemed necessary.

<i>Signature of Tenderer</i>	<i>Date</i>	<i>Name and Surname</i>	<i>Address</i>

For official use.		
SIGNATURE OF CCT OFFICIALS AT TENDER OPENING		
1.	2.	3.

Schedule F.5: Declaration of Interest – State Employees (MBD 4 amended)
--

1. No bid will be accepted from:
 - 1.1 persons in the service of the state¹, or
 - 1.2 if the person is not a natural person, of which any director, manager or principal shareholder or stakeholder is in the service of the state, or
 - 1.3 from persons, or entities of which any director, manager or principal shareholder or stakeholder, has been in the service of the City of Cape Town (CCT) during the previous twelve (12) months, or
 - 1.4 from an entity who has employed a former CCT employee who was at a level of T14 or higher at the time of leaving the CCT's employ and involved in any of the CCT's bid committees for the bid submitted, if:
 - 1.4.1 the CCT employee left the CCT's employment voluntarily, during the previous twelve (12) months;
 - 1.5 a person who was a CCT employee, or an entity that employs a CCT employee, if
 - 1.5.1 the CCT employee left the CCT's employment whilst under investigation for alleged misconduct, or
 - 1.5.2 was facing disciplinary action or potential disciplinary action by the CCT, or
 - 1.5.3 was involved in a dispute against the CCT during the previous thirty six (36) months.

2. Any person, having a kinship with persons in the service of the state, including a blood relationship, may make an offer or offers in terms of this invitation to bid. In view of possible allegations of favouritism, should the resulting bid, or part thereof, be awarded to persons connected with or related to persons in service of the state, it is required that the tenderer or their authorised representative declare their position in relation to the evaluating/adjudicating authority.

3. In order to give effect to the above, the following questionnaire must be completed and submitted with the bid.
 - 3.1 Full Name of tenderer or his or her representative: _____
 - 3.2 Identity Number: _____
 - 3.3 Position occupied in the Company (director, trustee, shareholder²): _____
 - 3.4 Company or Close Corporation Registration Number: _____
 - 3.5 Tax Reference Number: _____
 - 3.6 VAT Registration Number: _____
 - 3.7 The names of all directors / trustees / shareholders members, their individual identity numbers and state employee numbers must be indicated in paragraph 4 below.
 - 3.8 Are you presently in the service of the state? **YES / NO**
 - 3.8.1 If yes, furnish particulars: _____
 - 3.9 Have you been in the service of the state for the past twelve months? **YES / NO**
 - 3.9.1 If yes, furnish particulars: _____
 - 3.10 Do you have any relationship (family, friend, other) with persons in the service of the state and who may be involved with the evaluation and or adjudication of this bid? **YES / NO**
 - 3.10.1 If yes, furnish particulars: _____
 - 3.11 Are you, aware of any relationship (family, friend, other) between any other tenderer and any persons in the service of the state who may be involved with the evaluation and or adjudication of this bid? **YES / NO**
 - 3.11.1 If yes, furnish particulars: _____
 - 3.12 Are any of the company's directors, trustees, managers, principle shareholders or stakeholders in service of the state? **YES / NO**
 - 3.12.1 If yes, furnish particulars: _____

- 3.13 Are any spouse, child or parent of the company's directors, trustees, managers, principle shareholders or stakeholders in service of the state? **YES / NO**
 3.13.1 If yes, furnish particulars: _____
- 3.14 Do you or any of the directors, trustees, managers, principle shareholders, or stakeholders of this company have any interest in any other related companies or business whether or not they are bidding for this contract? **YES / NO**
 3.14.1 If yes, furnish particulars: _____
- 3.15 Have you, or any of the directors, trustees, managers, principle shareholders, or stakeholders of this company been in the service of the CCT in the past twelve months? **YES / NO**
 3.15.1 If yes, furnish particulars: _____
- 3.16 Do you have any employees who was in the service of the CCT at a level of T14 or higher at the time they left the employ of the CCT, and who was involved in any of the CCT's bid committees for this bid? **YES / NO**
 3.16.1 If yes, furnish particulars: _____

4. Full details of directors / trustees / members / shareholders

Full Name	Identity Number	State Employee Number

If the above table does not sufficient to provide the details of all directors / trustees / shareholders, please append full details to the tender submission.

The tenderer hereby certifies that the information set out in this schedule and/or attached hereto is true and correct, and acknowledges that failure to properly and truthfully complete this schedule may result in steps being taken against the tenderer, the tender being disqualified, and/or (in the event that the tenderer is successful) the cancellation of the contract, restriction of the tenderer or the exercise by the CCT of any other remedies available to it.

 Signature
 Print name: _____ Date
 On behalf of the tenderer (duly authorised)

- 'MSCM Regulations: "in the service of the state" means to be –**
- (a) **a member of –**
 - (i) **any municipal council;**
 - (ii) **any provincial legislature; or**
 - (iii) **the national Assembly or the national Council of provinces;**
 - (b) **a member of the board of directors of any municipal entity;**
 - (c) **an official of any municipality or municipal entity;**
 - (d) **an employee of any national or provincial department, national or provincial public entity or constitutional institution within the meaning of the Public Finance Management Act, 1999 (Act No.1 of 1999);**
 - (e) **an executive member of the accounting authority of any national or provincial public entity; or**
 - (f) **an employee of Parliament or a provincial legislature.**

² **Shareholder" means a person who owns shares in the company and is actively involved in the management of the company or business and exercises control over the company.**

Schedule F.6: Conflict of Interest Declaration

1. The tenderer shall declare whether it has any conflict of interest in the transaction for which the tender is submitted. **(Please mark with X)**

YES		NO	
-----	--	----	--

- 1.1 If yes, the tenderer is required to set out the particulars in the table below:

2. The tenderer shall declare whether it has directly or through a representative or intermediary promised, offered or granted:

- 2.1 Any inducement or reward to the CCT for or in connection with the award of this contract; or

- 2.2 Any reward, gift, favour or hospitality to any official or any other role player involved in the implementation of the supply chain management policy. **(Please mark with X)**

YES		NO	
-----	--	----	--

- If yes, the tenderer is required to set out the particulars in the table below:

Should the tenderer be aware of any corrupt or fraudulent transactions relating to the procurement process of the CCT, please contact the following:

The CCT's anti-corruption hotline at 0800 32 31 30 (toll free)

The tenderer hereby certifies that the information set out in this schedule and/or attached hereto is true and correct, and acknowledges that failure to properly and truthfully complete this schedule may result in steps being taken against the tenderer, the tender being disqualified, and/or (in the event that the tenderer is successful) the cancellation of the contract, restriction of the tenderer or the exercise by the CCT of any other remedies available to it.

Signature
Print name:
On behalf of the tenderer (duly authorised)

Date

Schedule F.7: Declaration of Tenderer's Past Supply Chain Management Practices (MBD 8)

Where the entity tendering is a partnership/joint venture/consortium, each party to the partnership/joint venture/consortium must sign a declaration in terms of the Municipal Finance Management Act, Act 56 of 2003, and attach it to this schedule.

- 1 The tender offer of any tenderer may be rejected if that tenderer or any of its directors/members have:
- a) abused the municipality's / municipal entity's supply chain management system or committed any fraudulent conduct in relation to such system;
 - b) been convicted for fraud or corruption during the past five years;
 - c) willfully neglected, reneged on or failed to comply with any government, municipal or other public sector contract during the past five years; or
 - d) been listed in the Register for Tender Defaulters in terms of section 29 of the Prevention and Combating of Corrupt Activities Act (No 12 of 2004) or Database of Restricted Suppliers.
- 2 In order to give effect to the above, the following questionnaire must be completed and submitted with the bid.

Item	Question	Yes	No
2.1	<p>Is the tenderer or any of its directors/members listed on the National Treasury's Database of Restricted Suppliers as companies or persons prohibited from doing business with the public sector?</p> <p>(Companies or persons who are listed on this Database were informed in writing of this restriction by the Accounting Officer/Authority of the institution that imposed the restriction after the <i>audi alteram partem</i> rule was applied).</p> <p>The Database of Restricted Suppliers now resides on the National Treasury's website (www.treasury.gov.za) and can be accessed by clicking on its link at the bottom of the home page.</p>	Yes <input type="checkbox"/>	No <input type="checkbox"/>
2.1.1	If so, furnish particulars:		
2.2	<p>Is the tenderer or any of its directors/members listed on the Register for Tender Defaulters in terms of section 29 of the Prevention and Combating of Corrupt Activities Act (No 12 of 2004) or Database of Restricted Suppliers?</p> <p>The Register for Tender Defaulters can be accessed on the National Treasury's website (www.treasury.gov.za) by clicking on its link at the bottom of the home page.</p>	Yes <input type="checkbox"/>	No <input type="checkbox"/>
2.2.1	If so, furnish particulars:		
2.3	<p>Was the tenderer or any of its directors/members convicted by a court of law (including a court of law outside the Republic of South Africa) for fraud or corruption during the past five years?</p>	Yes <input type="checkbox"/>	No <input type="checkbox"/>
2.3.1	If so, furnish particulars:		
Item	Question	Yes	No

2.4	Does the tenderer or any of its directors owe any municipal rates and taxes or municipal charges to the municipality / municipal entity, or to any other municipality / municipal entity, that is in arrears for more than three months?	Yes <input type="checkbox"/>	No <input type="checkbox"/>
2.4.1	If so, furnish particulars:		
2.5	Was any contract between the tenderer and the municipality / municipal entity or any other organ of state terminated during the past five years on account of failure to perform on or comply with the contract?	Yes <input type="checkbox"/>	No <input type="checkbox"/>
2.5.1	If so, furnish particulars:		

The tenderer hereby certifies that the information set out in this schedule and/or attached hereto is true and correct, and acknowledges that failure to properly and truthfully complete this schedule may result in steps being taken against the tenderer, the tender being disqualified, and/or (in the event that the tenderer is successful) the cancellation of the contract,, restriction of the tenderer or the exercise by the CCT of any other remedies available to it.

 Signature
 Print name:
 On behalf of the tenderer (duly authorised)

 Date

Schedule F.8: Authorisation for the Deduction of Outstanding Amounts Owed to the CCT

To: THE CITY MANAGER, City of Cape Town

From: _____
(Name of tenderer)

RE: AUTHORISATION FOR THE DEDUCTION OF OUTSTANDING AMOUNTS OWED TO THE CCT

The tenderer:

- a) hereby acknowledges that according to SCM Regulation 38(1)(d)(i) the City Manager may reject the tender of the tenderer if any municipal rates and taxes or municipal service charges owed by the tenderer (or any of its directors/members/partners) to the CCT, or to any other municipality or municipal entity, are in arrears for more than 3 (three) months; and
- b) therefore hereby agrees and authorises the CCT to deduct the full amount outstanding by the Tenderer or any of its directors/members/partners from any payment due to the tenderer; and
- c) confirms the information as set out in the tables below for the purpose of giving effect to b) above;

Physical Business address(es) of the tenderer	Municipal Account number(s)	Inside the CCT municipal boundary (Yes/No)

If there is not enough space for all the names, please attach the information to **List of other documents attached by tenderer** schedule in the same format:

Name of Director / Member / Partner	Identity Number	Physical residential address of Director / Member / Partner	Municipal Account number(s)	Inside the CCT municipal boundary (Yes/No)

The tenderer hereby certifies that the information set out in this schedule and/or attached hereto is true and correct, and acknowledges that failure to properly and truthfully complete this schedule may result in steps being taken against the tenderer, the tender being disqualified, and/or (in the event that the tenderer is successful) the cancellation of the contract, restriction of the tenderer or the exercise by the CCT of any other remedies available to it.

Signature
Print name:
On behalf of the tenderer (duly authorised)

Date

Schedule F.9: Certificate of Independent Tender Determination
--

I, the undersigned, in submitting this tender number **241G/2023/24** and tender description: **Supply and Delivery of Landfill Plant and Equipment** in response to the tender invitation made by THE CCT, do hereby make the following statements, which I certify to be true and complete in every respect:

I certify, on behalf of: _____ (Name of tenderer) that:

1. I have read and I understand the contents of this Certificate;
2. I understand that this tender will be disqualified if this Certificate is found not to be true and complete in every respect;
3. I am authorised by the tenderer to sign this Certificate, and to submit this tender, on behalf of the tenderer;
4. Each person whose signature appears on this tender has been authorised by the tenderer to determine the terms of, and to sign, the tender on behalf of the tenderer;
5. For the purposes of this Certificate and this tender, I understand that the word 'competitor' shall include any individual or organisation other than the tenderer, whether or not affiliated with the tenderer, who:
 - (a) has been requested to submit a tender in response to this tender invitation;
 - (b) could potentially submit a tender in response to this tender invitation, based on their qualifications, abilities or experience; and
 - (c) provides the same goods and services as the tenderer and/or is in the same line of business as the tenderer.
6. The tenderer has arrived at this tender independently from and without consultation, communication, agreement or arrangement with any competitor. However, communication between partners in a joint venture or consortium¹ will not be construed as collusive price quoting.
7. In particular, without limiting the generality of paragraphs 5 and 6 above, there has been no consultation, communication, agreement or arrangement with any competitor regarding:
 - (a) prices;
 - (b) geographical area where product or service will be rendered (market allocation);
 - (c) methods, factors or formulas used to calculate prices;
 - (d) the intention or decision to submit or not to submit a tender;
 - (e) the submission of a tender which does not meet the specifications and conditions of the tender; or
 - (f) tendering with the intention not to win the contract.
8. In addition, there have been no consultations, communications, agreements or arrangements with any competitor regarding the quality, quantity, specifications and conditions or delivery particulars of the products or services to which this tender invitation relates.
9. The terms of this tender have not been and will not be disclosed by the tenderer, directly or indirectly, to any competitor, prior to the date and time of the official tender opening or of the awarding of the contract.
10. I am aware that, in addition and without prejudice to any other remedy provided to combat any restrictive practices related to tenders and contracts, tenders that are suspicious will be reported to the Competition Commission for investigation and possible imposition of administrative penalties in terms of section 59 of the Competition Act, Act 89 of 1998, and/o/r may be reported to the National Prosecuting Authority (NPA) for criminal investigation, and/or may be restricted from conducting business with the public sector for a period not exceeding 10 (ten) years in terms of the Prevention and Combating of Corrupt Activities Act, Act 12 of 2004, or any other applicable legislation.

Signature

Print name:

On behalf of the tenderer (duly authorised)

Date

(¹ Consortium: Joint venture or Consortium means an association of persons for the purpose of combining their expertise, property, capital, efforts, skill and knowledge in an activity for the execution of a contract.)

Schedule F.11: List of Other Documents Attached By Tenderer
--

The tenderer has attached to this schedule, the following additional documentation:

	Date of Document	Title of Document or Description (refer to clauses / schedules of this tender document where applicable)
1.		
2.		
3.		
4.		
5.		
6.		
7.		
8.		
9.		
10.		
11.		
12.		
13.		
14.		
15.		
16.		
17.		

Attach additional pages if more space is required.

 Signature
 Print name:
 On behalf of the tenderer (duly authorised)

 Date

Schedule F.12: Record of Addenda to Tender Documents

We confirm that the following communications received from the CCT before the submission of this tender offer, amending the tender documents, have been taken into account in this tender offer:

	Date	Title or Details
1.		
2.		
3.		
4.		
5.		
6.		
7.		
8.		
9.		
10.		

Attach additional pages if more space is required.

 Signature
 Print name:
 On behalf of the tenderer (duly authorised)

 Date

Schedule F.13: Information to Be Provided With the Tender

The following information shall be provided with the Tender:

1. Technical Brochure/Data Sheet with technical information on the product offered, as per clause 2.2.1.1.8. of the Tenderer's Obligations.
2. Specification (C.5), as per clause 2.2.1.1.9. of the Tenderer's Obligations.
3. OEM Confirmation Earthmoving Plant/Equipment Distributor, as per clause 2.2.1.1.10. of the Tenderer's Obligations.
4. OEM Approved Workshop Facilities confirmation letter that the workshop facilities offered are OEM approved as per clause 2.2.1.1.11. of the Tenderer's Obligations.

Failure to provide above mentioned documents will render the bid non-responsive

Signature
Print name:
On behalf of the tenderer (duly authorised)

Date

Schedule F.14: Appeal Application

annexure 'B'

OFFICIAL RECEIPT
(Valid only if printed
by official cash
receiving machine)

IRISITI ESESIKWENI
(Isemthethweni kuphela
xa ishicilelwe
ngumatshini wokukhupa
irisiti osesikweni.)

AMPTELIKE KWITANSIE
(Geldig alleenlik indien deur
amptelike kontantvangs
masjien gedruk.)

**GL DATA CAPTURE RECEIPT
(CASHIERTO RETAIN A COPY)**

RECEIPT NO: _____

DATE: _____

SAP GL:

8	1	0	1	0	0
---	---	---	---	---	---

PROFIT CENTRE:

1	3	0	5	0	0	0	0	1
---	---	---	---	---	---	---	---	---

NAME/COMPANY NAME:

AMOUNT:

					R	3	0	0	-	0	0
--	--	--	--	--	---	---	---	---	---	---	---

SERVICE DEPARTMENT DETAILS-

DEPARTMENT: LEGAL SERVICES: APPEALS UNIT

CONTACT PERSON: CHARLENE CEBEKHULU / MELANIE CLOETE

PHONE NO: 021 400 2503 / 021 400 3788

OFFICIAL RECEIPT
(Valid only if printed
by official cash
receiving machine)

IRISITI ESESIKWENI
(Isemthethweni kuphela
xa ishicilelwe
ngumatshini wokukhupa
irisiti osesikweni.)

AMPTELIKE KWITANSIE
(Geldig alleenlik indien deur
amptelike kontantvangs
masjien gedruk.)

**GL DATA CAPTURE RECEIPT
(CASHIERTO RETAIN A COPY)**

RECEIPT NO: _____

DATE: _____

SAP GL:

8	1	0	1	0	0
---	---	---	---	---	---

PROFIT CENTRE:

1	3	0	5	0	0	0	0	1
---	---	---	---	---	---	---	---	---

NAME/COMPANY NAME:

AMOUNT:

					R	3	0	0	-	0	0
--	--	--	--	--	---	---	---	---	---	---	---

SERVICE DEPARTMENT DETAILS-

DEPARTMENT: LEGAL SERVICES: APPEALS UNIT

CONTACT PERSON: CHARLENE CEBEKHULU / MELANIE CLOETE

PHONE NO: 021 400 2503 / 021 400 3788

CIVIC CENTRE IZIKO LOLUNTU BURGERSENTRUM
12 HERTZOG BOULEVARD CAPE TOWN 8001 P O BOX 298 CAPE TOWN 8000
www.capetown.gov.za

Making progress possible. Together.