

**PART A
INVITATION TO QUOTE (RFQ)**

YOU ARE HEREBY INVITED TO BID FOR REQUIREMENTS OF THE SOUTH AFRICAN MARITIME SAFETY AUTHORITY				
REF NUMBER: 1124.1 Mini VRF air conditioning system for server room		CLOSING DATE: 24 April 2024	CLOSING TIME: 10H00	
COMPULSORY BRIEFING SESSION	DATE: 16 th April 2024 TIME: 11H00 ADDRESS: 6 th Floor, Cardinal Properties, No. 2 Samora Machel Street, Durban			
DELIVERY ADDRESS	SAMSA (DURBAN OFFICE) 6 th Floor, Cardinal Properties, No. 2 Samora Machel Street, Durban ** LOCALITY GOAL POINTS WILL ONLY BE AWARDED TO SUPPLIERS WITHIN THE PROVINCE OF DELIVERY			
DESCRIPTION/ SPECIFICATION	REFER TO ANNEXURE A FOR THE FULL DESCRIPTION OF GOODS / SERVICES REQUIRED			
QUOTE OR PROPOSAL DOCUMENTS MAY BE DELIVERED TO THE BELOW STREET ADDRESS PRIOR CLOSING DATE & TIME				
SAMSA (HEAD OFFICE), 146 LUNNON ROAD, HILLCREST, PRETORIA, 0083				
QUOTATION PROCEDURE ENQUIRIES MAY BE DIRECTED TO		TECHNICAL ENQUIRIES MAY BE DIRECTED TO:		
CONTACT PERSON	TULETU NGQOLOWA / NOMFUNDO MJI		CONTACT PERSON	ONTIRETSE LEKGOANE
TELEPHONE NUMBER	012 366 2600		TELEPHONE NUMBER	012 366 2600
FACSIMILE NUMBER	N/A		FACSIMILE NUMBER	N/A
E-MAIL ADDRESS	tngqolowa@samsa.org.za nmji@samsa.org.za		E-MAIL ADDRESS	olekgoane@samsa.org.za
SUPPLIER INFORMATION				
NAME OF BIDDER				
POSTAL ADDRESS				
STREET ADDRESS				
TELEPHONE NUMBER	CODE		NUMBER	
CELLPHONE NUMBER				
FACSIMILE NUMBER	CODE		NUMBER	
E-MAIL ADDRESS				
VAT REGISTRATION NUMBER				
SUPPLIER COMPLIANCE STATUS	TAX COMPLIANCE SYSTEM PIN:		CENTRAL SUPPLIER DATABASE No:	MAAA
B-BBEE STATUS LEVEL VERIFICATION CERTIFICATE	TICK APPLICABLE BOX <input type="checkbox"/> Yes <input type="checkbox"/> No		B-BBEE STATUS LEVEL SWORN AFFIDAVIT	[TICK APPLICABLE BOX] <input type="checkbox"/> Yes <input type="checkbox"/> No
[A B-BBEE STATUS LEVEL VERIFICATION CERTIFICATE/ SWORN AFFIDAVIT (FOR EMES & QSEs) MUST BE SUBMITTED IN ORDER TO QUALIFY FOR PREFERENCE POINTS FOR B-BBEE]				

ARE YOU THE ACCREDITED REPRESENTATIVE IN SOUTH AFRICA FOR THE GOODS /SERVICES /WORKS OFFERED?	<input type="checkbox"/> Yes <input type="checkbox"/> No [IF YES ENCLOSE PROOF]	ARE YOU A FOREIGN BASED SUPPLIER FOR THE GOODS /SERVICES /WORKS OFFERED?	<input type="checkbox"/> Yes <input type="checkbox"/> No [IF YES, ANSWER THE QUESTIONNAIRE BELOW]
---	--	--	--

QUESTIONNAIRE TO BIDDING FOREIGN SUPPLIERS

IS THE ENTITY A RESIDENT OF THE REPUBLIC OF SOUTH AFRICA (RSA)?	<input type="checkbox"/> YES <input type="checkbox"/> NO
DOES THE ENTITY HAVE A BRANCH IN THE RSA?	<input type="checkbox"/> YES <input type="checkbox"/> NO
DOES THE ENTITY HAVE A PERMANENT ESTABLISHMENT IN THE RSA? NO	<input type="checkbox"/> YES <input type="checkbox"/>
DOES THE ENTITY HAVE ANY SOURCE OF INCOME IN THE RSA?	<input type="checkbox"/> YES <input type="checkbox"/> NO
IS THE ENTITY LIABLE IN THE RSA FOR ANY FORM OF TAXATION?	<input type="checkbox"/> YES <input type="checkbox"/> NO
IF THE ANSWER IS "NO" TO ALL OF THE ABOVE, THEN IT IS NOT A REQUIREMENT TO REGISTER FOR A TAX COMPLIANCE STATUS SYSTEM PIN CODE FROM THE SOUTH AFRICAN REVENUE SERVICE (SARS) AND IF NOT REGISTER AS PER 2.3 BELOW.	

**PART B
TERMS AND CONDITIONS FOR QUOTING/BIDDING**

1. QUOTE SUBMISSION:

- 1.1. QUOTES MUST BE DELIVERED OR EMAILED BY THE STIPULATED TIME TO THE CORRECT ADDRESS AND EMAIL ADDRESS. LATE QUOTES WILL NOT BE ACCEPTED FOR CONSIDERATION.
- 1.2. **ALL QUOTES MUST BE SUBMITTED ON THE OFFICIAL FORMS PROVIDED- OR IN THE MANNER PRESCRIBED IN THE RFQ DOCUMENT.**
- 1.3. THE RFQ MAY BE SUBJECT TO THE PREFERENTIAL PROCUREMENT POLICY FRAMEWORK ACT, 2000 AND THE PREFERENTIAL PROCUREMENT REGULATIONS, 2022, IF THE AMOUNT IS ABOVE R2 000,00 OR THE GENERAL CONDITIONS OF CONTRACT (GCC) AND, IF APPLICABLE, ANY OTHER SPECIAL CONDITIONS OF CONTRACT.
- 1.4. PROSPECTIVE BIDDERS MUST CONSIDER **ANNEXURE A** FOR THE SPECIFICATION & ADDITIONAL SUPPORTING DOCUMENTATION.
- 1.5. ALL INFORMATION SUBMITTED AS EVIDENCE MUST BE CONSISTENT WITH DECLARATIONS MADE TO BE AWARDED POINTS. INCONSISTENT INFORMATION PROVIDED MAY RESULT IN 0 POINTS AWARDED FOR THE APPLICABLE GOAL. SAMSA RESERVES THE RIGHT TO DISQUALIFY BIDDERS WITH SUPPORTING DOCUMENTS THAT ARE NOT DULY SUBMITTED IN TERMS OF THE BID CONDITIONS
- 1.6. DELIVERY COSTS IN THE QUOTATION WILL NOT BE CONSIDERED SEPARATELY, BUT RATHER AS PART OF THE TOTAL QUOTATION DURING THE EVALUATION.
- 1.7. **THE SUCCESSFUL BIDDER MAY BE REQUIRED TO FILL IN AND SIGN A WRITTEN CONTRACT FORM (SBD7) FOR LONG TERM PROJECT OR SERVICE.**

2. TAX COMPLIANCE REQUIREMENTS

- 2.1 BIDDERS MUST ENSURE COMPLIANCE WITH THEIR TAX OBLIGATIONS.
- 2.2 BIDDERS ARE REQUIRED TO SUBMIT THEIR UNIQUE PERSONAL IDENTIFICATION NUMBER (PIN) ISSUED BY SARS TO ENABLE THE ORGAN OF STATE TO VERIFY THE TAXPAYER'S PROFILE AND TAX STATUS.
- 2.3 APPLICATION FOR TAX COMPLIANCE STATUS (TCS) PIN MAY BE MADE VIA E-FILING THROUGH THE SARS WEBSITE WWW.SARS.GOV.ZA.
- 2.4 BIDDERS MAY ALSO SUBMIT A PRINTED TCS CERTIFICATE TOGETHER WITH THE QUOTE.
- 2.5 IN PROPOSAL OR QUOTE WHERE CONSORTIA / JOINT VENTURES / SUB-CONTRACTORS ARE INVOLVED; EACH PARTY MUST SUBMIT A SEPARATE TCS CERTIFICATE / PIN / CSD NUMBER.
- 2.6 WHERE NO TCS PIN IS AVAILABLE BUT THE BIDDER IS REGISTERED ON THE CENTRAL SUPPLIER DATABASE (CSD), A CSD NUMBER MUST BE PROVIDED.
- 2.7 NO BIDS WILL BE CONSIDERED FROM PERSONS IN THE SERVICE OF THE STATE, COMPANIES WITH DIRECTORS WHO ARE PERSONS IN THE SERVICE OF THE STATE, OR CLOSE CORPORATIONS WITH MEMBERS PERSONS IN THE SERVICE OF THE STATE."

NB: FAILURE TO PROVIDE / OR COMPLY WITH ANY OF THE ABOVE PARTICULARS MAY RENDER THE QUOTE INVALID.

SIGNATURE OF BIDDER: _____

CAPACITY UNDER WHICH THIS BID IS SIGNED: _____

DATE: _____

BIDDER'S DISCLOSURE

1. PURPOSE OF THE FORM

Any person (natural or juristic) may make an offer or offers in terms of this invitation to bid. In line with the principles of transparency, accountability, impartiality, and ethics as enshrined in the Constitution of the Republic of South Africa and further expressed in various pieces of legislation, it is required for the bidder to make this declaration in respect of the details required hereunder.

Where a person/s are listed in the Register for Tender Defaulters and / or the List of Restricted Suppliers, that person will automatically be disqualified from the bid process.

2. Bidder's declaration

2.1 Is the bidder, or any of its directors / trustees / shareholders / members / partners or any person having a controlling interest¹ in the enterprise, employed by the state? **YES/NO**

2.1.1 If so, furnish particulars of the names, individual identity numbers, and, if applicable, state employee numbers of sole proprietor/ directors / trustees / shareholders / members/ partners or any person having a controlling interest in the enterprise, in table below.

Full Name	Identity Number	Name of State institution

2.2 Do you, or any person connected with the bidder, have a relationship with any person who is employed by the procuring institution? **YES/NO**

2.2.1 If so, furnish particulars:

2.3 Does the bidder or any of its directors / trustees / shareholders / members / partners or any person having a controlling interest in the enterprise have any interest in any other related enterprise whether or not they are bidding for this contract? **YES/NO**

2.3.1 If so, furnish particulars:

3 DECLARATION

I, the undersigned, (name)..... in submitting the accompanying bid, do hereby make the following statements that I certify to be true and complete in every respect:

- 3.1 I have read, and I understand the contents of this disclosure.
- 3.2 I understand that the accompanying bid will be disqualified if this disclosure is found not to be true and complete in every respect.
- 3.3 The bidder has arrived at the accompanying bid independently from, and without consultation, communication, agreement, or arrangement with any competitor. However, communication between partners in a joint venture or consortium² will not be construed as collusive bidding.
- 3.4 In addition, there have been no consultations, communications, agreements, or arrangements with any competitor regarding the quality, quantity, specifications, prices, including methods, factors or formulas used to calculate prices, market allocation, the intention or decision to submit or not to submit the bid, bidding with the intention not to win the bid and conditions or delivery particulars of the products or services to which this bid invitation relates.
- 3.5 The terms of the accompanying bid have not been, and will not be, disclosed by the bidder, directly or indirectly, to any competitor, prior to the date and time of the official bid opening or of the awarding of the contract.
- 3.6 There have been no consultations, communications, agreements or arrangements made by the bidder with any official of the procuring institution in relation to this procurement process prior to and during the bidding process except to provide clarification on the bid submitted where so required by the institution; and the bidder was not involved in the drafting of the specifications or terms of reference for this bid.
- 3.7 I am aware that, in addition and without prejudice to any other remedy provided to combat any restrictive practices related to bids and contracts, bids that are suspicious will be reported to the Competition Commission for investigation and possible imposition of administrative penalties in terms of section 59 of the Competition Act No 89 of 1998 and or may be reported to the National Prosecuting Authority (NPA) for criminal investigation and or may be restricted from conducting business with the public sector for a period not exceeding ten (10) years in terms of the Prevention and Combating of Corrupt Activities Act No 12 of 2004 or any other applicable legislation.

I CERTIFY THAT THE INFORMATION FURNISHED IN PARAGRAPHS 1, 2 and 3 ABOVE IS CORRECT.

I ACCEPT THAT THE STATE MAY REJECT THE BID OR ACT AGAINST ME IN TERMS OF PARAGRAPH 6 OF PFMA SCM INSTRUCTION 03 OF 2021/22 ON PREVENTING AND COMBATING ABUSE IN THE SUPPLY CHAIN MANAGEMENT SYSTEM SHOULD THIS DECLARATION PROVE TO BE FALSE.

.....
Signature

.....
Date

.....
Position

.....
Name of bidder

PREFERENCE POINTS CLAIM FORM IN TERMS OF THE PREFERENTIAL PROCUREMENT REGULATIONS 2022

This preference form must form part of all bids invited. It contains general information and serves as a claim form for preference points for specific goals.

NB: BEFORE COMPLETING THIS FORM, BIDDERS MUST STUDY THE GENERAL CONDITIONS, DEFINITIONS AND DIRECTIVES APPLICABLE IN RESPECT OF THE BID AND PREFERENTIAL PROCUREMENT REGULATIONS, 2022

1. GENERAL CONDITIONS

- 1.1 The following preference point systems are applicable to invitations to bid:
 - the 80/20 system for requirements with a Rand value of up to R50 000 000 (all applicable taxes included); and
 - the 90/10 system for requirements with a Rand value above R50 000 000 (all applicable taxes included).
- 1.2 Either the 90/10 or 80/20 preference point system will be applicable in this bid. The lowest/highest acceptable bid will be used to determine the accurate system once bids are received.
- 1.3 Points for this bid (even in the case of a bid for income-generating contracts) shall be awarded for:
 - (a) Price; and
 - (b) Specific Goals.
- 1.4 The preference point system application must not exceed 100 and must be applied as per below:
 - 1.4.1 The 80/20 preference system:

The maximum points for this bid are allocated as follows:

	POINTS
PRICE	80
SPECIFIC GOALS**	20
Total points for Price and SPECIFIC GOALS	100

** Point allocation break down provide below

1.4.1.1 SPECIFIC GOALS: 80/20

SPECIFIC GOAL	Points
Goal 1: Historically Disadvantaged Individuals (14)	
a) who had no franchise in national elections before the 1983 and 1993 Constitutions	7
b) who is a female	5
c) who has a disability	2
Goal 2: who is youth	3
Goal 3: Locality	3
TOTAL	20

1.4.2 The 90/10 preference system:
The maximum points for this bid are allocated as follows:

	POINTS
PRICE	90
SPECIFIC GOALS**	10
Total points for Price and SPECIFIC GOALS	100

** Point allocation break down provide below

1.4.2.1 SPECIFIC GOALS: 90/10

SPECIFIC GOAL	Points
Goal 1: Historically Disadvantaged Individuals (14)	
a) who had no franchise in national elections before the 1983 and 1993 Constitutions	4
b) who is a female	2
c) who has a disability	1
Goal 2: who is youth	1
Goal 3: Locality	2
TOTAL	10

1.5 Failure on the part of a bidder to submit proof or documentation required in terms of this bid to claim points for specific goals with the bid, will be interpreted to mean that preference points for specific goals are not claimed.

1.6 SAMSA reserves the right to require of a bidder, either before a bid is adjudicated or at any time subsequently, to substantiate any claim in regard to preferences, in any manner required

by SAMSA.

2. DEFINITIONS

- (a) **“locality”** means the promotion of SMMEs located within the specific area;
- (b) **“bid”** means a written offer in the form determined by an organ of state in response to an invitation to provide goods or services through price quotations, competitive bidding process or any other method envisaged in legislation;
- (c) **“price”** means an amount of money bided for goods or services, and includes all applicable taxes less all unconditional discounts;
- (d) **“rand value”** means the total estimated value of a contract in Rand, calculated at the time of bid invitation, and includes all applicable taxes;
- (e) **“bid for income-generating contracts”** means a written offer in the form determined by an organ of state in response to an invitation for the origination of income-generating contracts through any method envisaged in legislation that will result in a legal agreement between SAMSA and a third party that produces revenue for SAMSA, and includes, but is not limited to, leasing and disposal of assets and concession contracts, excluding direct sales and disposal of assets through public auctions; and
- (f) **“the Act”** means the Preferential Procurement Policy Framework Act, 2000 (Act No. 5 of 2000).

3. FORMULAE FOR PROCUREMENT OF GOODS AND SERVICES

3.1. POINTS AWARDED FOR PRICE

3.1.1 THE 80/20 OR 90/10 PREFERENCE POINT SYSTEMS

A maximum of 80 or 90 points is allocated for price on the following basis:

$$\begin{array}{ccc} \mathbf{80/20} & \mathbf{or} & \mathbf{90/10} \\ P_s = 80 \left(1 - \frac{P_t - P}{P}\right) & \mathbf{or} & P_s = 90 \left(1 - \frac{P_t - P}{P}\right) \end{array}$$

Where

P_s = Points scored for price of bid under consideration

P_t = Price of bid under consideration

P_{min} = Price of lowest acceptable bid

3.2. FORMULAE FOR DISPOSAL OR LEASING OF STATE ASSETS AND INCOME GENERATING PROCUREMENT

3.2.1. POINTS AWARDED FOR PRICE

A maximum of 80 or 90 points is allocated for price on the following basis:

$$\begin{array}{ccc} \mathbf{80/20} & \mathbf{or} & \mathbf{90/10} \\ P_s = 80 \left(1 + \frac{P_t - P}{P}\right) & \mathbf{or} & P_s = 90 \left(1 + \frac{P_t - P}{P_{max}}\right) \end{array}$$

Where

- Ps = Points scored for price of bid under consideration
- Pt = Price of bid under consideration
- Pmax = Price of highest acceptable bid

4. POINTS AWARDED FOR SPECIFIC GOALS

4.1. Specific goals for the bid and points claimed are indicated per the table below.

4.1.1. EQUITY OWNERSHIP CLAIMED IN TERMS OF PARAGRAPH 1.4

	SPECIFIC GOAL & SUPPORTING DOCUMENTS FOR VERIFICATION	Maximum points	How many percent of the maximum points are you claiming between 0-100%?
HDI	Equity ownership by persons who had no franchise in the national elections. (ID copies of ALL listed owner/s, as per the CSD, CK1 registration document (CIPC), BBBEE certificate)	7	
	Equity ownership by women (ID copies of ALL listed owner/s, BBBEE certificate)	5	
	Equity ownership by disabled persons (Medical certificate/ Assessment)	2	
	Equity ownership by youth (ID copies of ALL listed owner/s, BBBEE certificate)	3	
	Locality (Proof of address not older than 3 months)	3	

**** Points can only be allocated where supporting documents have been provided. You may use the checklist attached on the last page.**

5. DECLARATION WITH REGARD TO COMPANY/FIRM

5.1. Name of company/firm.....

5.2. Company registration number:

5.3. Company/ firm physical address (for claiming locality points):
.....
.....

5.4. TYPE OF COMPANY/ FIRM

- Partnership/Joint Venture / Consortium
- One-person business/sole propriety
- Close corporation
- Public Company
- Personal Liability Company
- (Pty) Limited

- Non-Profit Company
 - State Owned Company
- [TICK APPLICABLE BOX]

5.5. DESCRIBE PRINCIPAL BUSINESS ACTIVITIES

.....

.....

.....

.....

5.6. TOTAL NUMBER OF YEARS THE COMPANY/ FIRM HAS BEEN IN BUSINESS?

.....

5.7. List of shareholder/s information to be used to calculate the points claimed in paragraph 4.3.

NAME	ID NUMBER	HDI**			Youth**	% of company / firm owned
		(**Yes / No)				
		No franchise prior to elections	Women	Disabled	(**Yes/ No)	

5.8. I, the undersigned, who is duly authorised to do so on behalf of the company/firm, certify that the points claimed, based on the specific goals as advised in the bid, qualifies the company/ firm for the preference(s) shown and I acknowledge that:

- i) The information furnished is true and correct;
- ii) The preference points claimed are in accordance with the General Conditions as indicated in paragraph 1 of this form;
- iii) In the event of a contract being awarded as a result of points claimed as shown in paragraphs 4.1 and 5.6, the contractor may be required to furnish documentary proof to the satisfaction of SAMSA that the claims are correct;
- iv) If the specific goals have been claimed or obtained on a fraudulent basis or any of the conditions of contract have not been fulfilled, SAMSA may, in addition to any other remedy it may have –
 - (a) disqualify the person from the bidding process;
 - (b) recover costs, losses or damages it has incurred or suffered as a result of that person's conduct;

- (c) cancel the contract and claim any damages which it has suffered as a result of having to make less favourable arrangements due to such cancellation;
- (d) recommend that the bidder or contractor, its shareholders and directors, or only the shareholders and directors who acted on a fraudulent basis, be restricted from obtaining business from any organ of state for a period not exceeding 10 years, after the *audi alteram partem* (hear the other side) rule has been applied; and
- (e) forward the matter for criminal prosecution, if deemed necessary.

.....	
SIGNATURE(S) OF BIDDER(S)	
SURNAME AND NAME:
DATE:
ADDRESS:

ANNEXURE A

SCOPE OF WORK & REQUIRED DOCUMENTS

1. COMPULSORY BRIEFING SESSION:

BIDDERS MUST ATTEND THE COMPULSORY BRIEFING SESSION TO PARTICIPATE IN THIS RFQ.

DETAILS:

DATE & TIME: 25 MARCH 2024 AT 11H00

VENUE: SAMSA (DURBAN OFFICE)

ADDRESS: Cardinal Properties, No. 2 Samora Machel Street, Durban, 4001

2. CLOSING DETAILS

CLOSING DATE & TIME: 03 APRIL 2024 AT 10H00

DOCUMENT DELIVERY ADDRESS: SAMSA (PRETORIA)

146 Lunnon Road, Hillcrest, Pretoria, 0183

DESCRIPTION OF GOODS/ SERVICES REQUIRED BY SAMSA
<ul style="list-style-type: none">- Supply, install and delivery of mini VRF air conditioning system complete with indoor and outdoor units. Including decorative panel, piping between indoor and outdoor portions of unit, mounting brackets, condensate drain pumps and all necessary accessories.- The installation to be done in the server room at the 6th floor at Cardinal Properties situated at No. 2 Samora Machel Street in Durban.- Refer to the attached office layout.- Please note that we have included mandatory requirements and a pre-qualification criterion, which will be used as part of our evaluation process.- Bidders are requested to submit a pricing proposal, while ensuring alignment of their submission with the mandatory and pre-qualification criteria to ensure correct allocation of points. Ensure that each element is addressed directly and clear responded to.

3. MANDATORY CRITERIA REQUIREMENTS:

Bidders must submit a valid letter of Good Standing in terms of Compensation for Occupational Injuries and Diseases Act of 1993 (COIDA).

Bidders who have not submitted proof of COIDA will not be considered for further evaluation, of the functionality criteria.

4. FUNCTIONALITY EVALUATION CRITERIA

Bidders will be assessed on their ability to complete the job as per the below criteria.

The functionality evaluation shall be based on a threshold, where bidders which fail to achieve the minimum threshold points will not be considered for further evaluation.

Points allocated for functionality shall be evaluated in accordance with the criteria as listed below.

A minimum score of 75 points out of a 100, must be achieved to be eligible for further evaluation on price / SAMSA goals (80/20) preference points.

CRITERIA		POINTS
<p>Reference letters</p> <p>The bidder must demonstrate experience in the installation of Mini VRF air conditioning system complete with indoor and outdoor units. The bidder must submit three (3) written referral letters within the past five (5) years in contract (signed and dated with contract details on official company letterhead).</p>	<p>Three (3) or more reference letters submitted within the installation of Mini VRF air conditioning system complete with indoor and outdoor units. - 15 points</p>	<p>15</p>
	<p>Two (2) reference letters submitted within the installation of Mini VRF air conditioning system complete with indoor and outdoor units. - 10 points</p>	
	<p>One (1) reference letter submitted within the installation of Mini VRF air conditioning system complete with indoor and outdoor units. - 5 points</p>	
	<p>Non-submission- 0 points</p>	
<p>Company Experience</p> <p>Bidders proven company experience related to similar service for the installation of Mini VRF air conditioning system complete with indoor and outdoor units.</p>	<p>Clearly outlined company experience with more than five years' experience. - 15 points</p>	<p>15</p>
	<p>Clearly outlined company experience with less than five years' experience. - 5 points</p>	
	<p>Non-submission- 0 points</p>	

<p>The service provider must have at least five (5) years or more experience in related in the installation of Mini VFR system.</p>		
<p>2.2 TEAM EXPERIENCE</p> <p>Highlight personnel years of experience, qualifications, and professional registration, Note who the key responsible person is and attach their CV and professional registration proof.</p>	<p>Responsible Person (Specifically HVAC) – 10 points (N3 certificate or higher in mechanical engineering) Non-submission- 0 points</p> <hr/> <p>Responsible Person (Specifically Electrical) – 10 points Diploma/ higher in (Electrical Engineering or Trade Test (electrical)) Non-submission- 0 points</p> <hr/> <p>Site supervision specifically in the Data Centre or critical facilities industry (HVAC) – 10 points Non-submission- 0 points</p>	30
<p>2.3 PROJECT PLAN</p> <p>Detailed project plan showing critical milestones, display logic to complete the project.</p> <p>This must include the expertise and resources required.</p> <p>As part of the resources required, the bidder must include information about ducting. The bidder must confirm if the ducts are manufactured or outsourced and outline the installation timeline.</p>	<p>Proposed outline workplan with timelines for delivery – 10 points Non-submission- 0 points</p> <hr/> <p>Provide an explanation of expertise and resources that would be used in - 10 points. Non-submission- 0 points</p> <hr/> <p>Ducting: manufactured and the timelines installation – 10 points Ducting outsourced and the timelines installation- 5 points Non-submission- 0 points</p>	30
<p>2.4 REGISTRATION WITH PROFESSIONAL BODY</p> <p>The bidder must be registered with the professional body. (Provide proof of valid registration – letter / certificate from the professional body)</p>	<p>South African Institute for Refrigeration and Air Conditioning (SAIRAC) or / and South African Refrigeration and Air Conditioning Contractors Association (SARACCA) -10 points Non-submission- 0 points</p>	10
<p>TOTAL POINTS</p>		100

SUPPLIER SECTION: PLEASE CONSIDER THE BELOW SECTION AND CHECKLIST

REQUIRED SUPPORTING DOCUMENTS & CHECKLIST

No.	Document description	Submitted (Yes / No)
1	Quotation	
2	Signed SBD (RFQ) Forms	
3	Recent CSD, not older than 3 months	
4	Tax pin certificate	
5	Valid B-BBEE	
6	CK1 registration document (CIPC)	
7	ID copies of ALL listed owner/s as per CSD report	
8	Proof of address not older than 3 months	
9	Medical certificate/ Assessment	

****ALL INFORMATION SUBMITTED WILL BE TREATED AS EVIDENCE FOR AWARDED POINTS FOR THE SAMSA GOALS AND MUST BE CONSISTENT WITH DECLARATIONS MADE. INCONSISTENT INFORMATION PROVIDED MAY RESULT IN 0 POINTS BEING AWARDED FOR THE APPLICABLE GOAL. SAMSA RESERVES THE RIGHT TO DISQUALIFY BIDDERS WITH SUPPORTING DOCUMENTS THAT ARE NOT DULY SUBMITTED IN TERMS OF THE BID CONDITIONS**

GUIDELINES FOR DOCUMENTS REQUIRED FOR THE VERIFICATION OF THE SAMSA GOALS

SPECIFIC GOAL	DOCUMENTS THAT WILL BE USED TO VERIFY THE INFORMATION SUPPLIED
Equity ownership by persons who had no franchise in the national elections	ID copies of all listed owner/s as per CSD report CK1 registration document (CIPC) BBBEE certificate
Equity ownership by women	ID copies of all listed owner/s as per CSD report BBBEE certificate
Equity ownership by disabled persons	Medical certificate/ Assessment
Equity ownership by youth	ID copies of all listed owner/s as per CSD report
Locality	Address (not older than 3 months) must be listed on the CSD, accompanied by a valid proof of residence, reflecting one of the listed owners' names and physical address. e.g., Utility bill, bank/ account statement, Municipal councillor's letter.

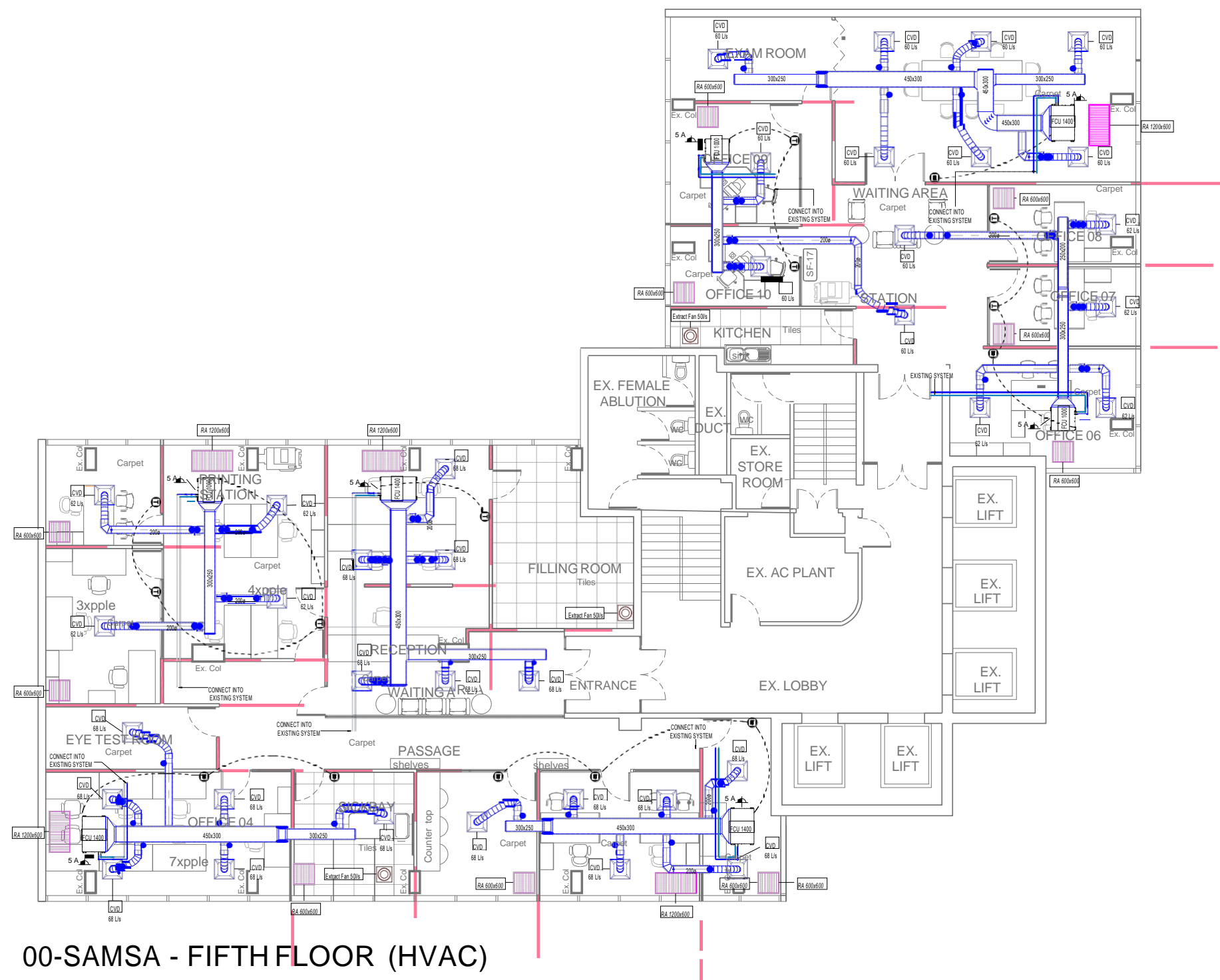

00-SAMSA - FIFTH FLOOR (HVAC)

1 : 100

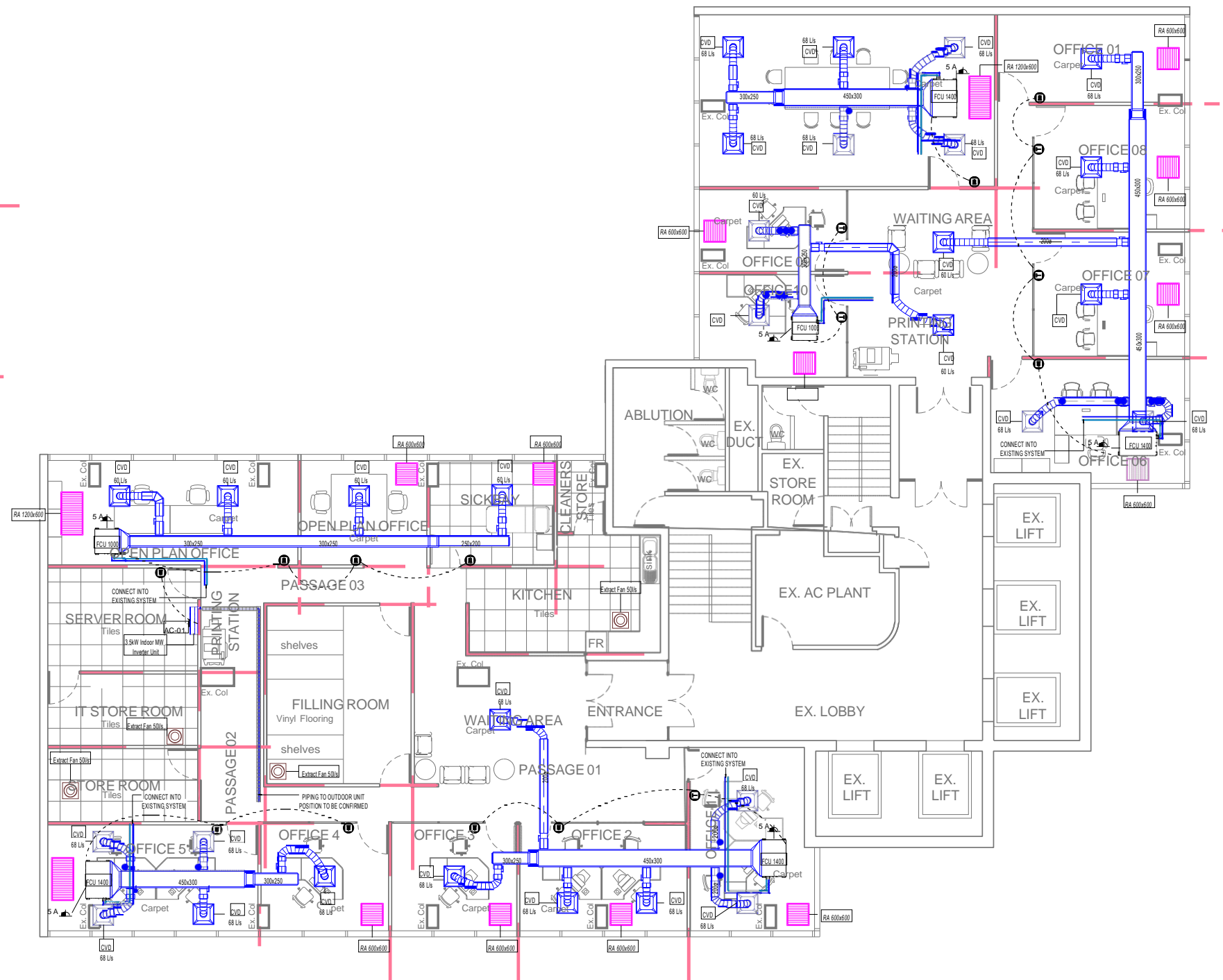

01-SAMSA - SIXTH FLOOR (HVAC)

1 : 100

- General Notes:**
1. This drawing is to be read in conjunction with drawings issued by the consultants of various disciplines, in particular: structural, electrical, mechanical and wet services engineers.
 2. Any discrepancies between drawings layouts are to be brought to the attention of the architects prior to any work being put in hand.
 3. Figured dimensions are to be taken in preference to scaled measurements and large scale details drawings will supersede small scale general layout drawings.
 4. Contractors and subcontractors to check all dimensions and levels on site prior to any work being put in hand.
 5. All work on site is to conform to good building practice and all relevant national codes and standards.
 6. The master held at Polygon Project Engineers bears the original signature of approval.
- Revisions:

No.	Date	Revision	Drawn
0	2023-11-15	ISSUED FOR CONSTRUCTION	PMC

- Single Phase
- Three Phase
- 5A Isolator
-
-

- LEGEND**
- Refrigerant piping basket
 - Ducting - Tempered fresh air
 - Ducting - Ventilation exhaust air
 - Ducting - Supply air
 - Ducting - Return air

Project Name:
SAMORA HOUSE
Project Description:
SAMSA FITOUT
Project Service:
MECHANICAL HVAC
Client:

Consultants:

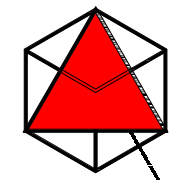

POLYGON PROJECT ENGINEERS
Polygon Project Engineers Pty (Ltd)
MS Baha | P: 0836731117 | E: msbaha@polygonprojectengineers.com
W: www.polygonprojectengineers.com | Facebook: Polygon Project Engineers

Drawing Issued:
FOR CONSTRUCTION
Consultant Approval:

Drawing Details:
SAMSA 5th & 6th FLOORS HVAC LAYOUT

Drawing Number: 2340-HVAC-LYT-01-01		Rev No.:
Date: 2023-11-15	Scale: 1 : 100	0
Paper Size: A1	Drawn: PMC	Checked: MSB
Client:	Date:	

COUNCIL APPROVAL SIGNOFF:

2340	Description	Model No.	Diam [mm]	Weight [kg]	Cooling [kW]	Heating [kW]	Flow [l/s]	V/PH/H Z	Power [kW]	Amps [A]	Quantity
FCU 1000	Fan Coil Unit	Carrier 42CT054 or similar approved	560(W)x242(H)x941(D)	20,3	4,5kW	3kW	250	240/1/50	0,51	0,43	5
FCU 1400	Fan Coil Unit	Carrier 42CT084 or similar approved	560(W)x242(H)x1421(D)	31,3	7,3kW	3kW	416	240/1/50	0,68	0,7	8
AC OUT 01	Outdoor Inverter Unit	MOX130 or similar approved	720(W)x495(H)x270(D)	24				240/1/50	2,2	10,5	1
AC MW 01	3,5kW Inverter Midwall	MSAG11B or similar approved	802(W)x295(H)x200(D)	22,3	3,42kW	3,6kW		240/1/50		4,68	1
EXTRACT...	Ceiling Mounted Extract Fan	LCE200 or similar approved	Ø100mm				50	240/1/50	0,0055	0,03	7

No	Description	Unit	Qty	Rate	Amount
A	<u>SAMSA Fitout</u>				
A1	<u>AIR CONDITIONING AND VENTILATION</u> <u>PRE-AMBLE</u>				
A2	Where trades names are used, it shall be read to include the phrase "or approved equal".				
A3	ACCEPTABLE TRADE NAMES: Midea, Samsung, LG, Carrier, McQuay, Panasonic, Trane, Daikin, York				
A4	Installation and Commissioning of Mini VRF air conditioning system complete with indoor and outdoor units. Including decorative panel, piping between indoor and outdoor portions of unit, mounting brackets, condensate drain pumps and all necessary accessories.				
A5	All items on the Bill are re-measurable				

B	<u>PRELIMINARY AND GENERAL</u>				
	<p>Note: All items shall be priced for whatever cost may be consider necessary for Preliminary and General to carry out the Mechanical Installations in full, as detailed in the drawings, Specifications and Schedules, which shall include, but shall not be limited, to the following:</p>				
B1	Mechanical Installations in full, as detailed in the drawings, Specifications and Schedules, which shall include, but shall not be limited, to the following:				
B2	Instructing and training the Employer's staff in operation of system and equipment prior to hand over to the Client.	Sum	1		
B3	Three copies of the O&M Manuals (hard copies and CD)	Sum	1		
B4	As-Built Drawings (3 copies)	Sum	1		
B5	Provision of full maintenance and guarantee of mechanical equipment and installation for the full 12 month period. The maintenance period shall start after practical completion is achieved. Service sheets to be submitted for every service carried out. Refer to tender specification.	Sum	1		
B6	<u>EXTRAS NOT LISTED ABOVE</u>				
B7	Scaffolding	Sum	1		
B8	Shop Drawings	Sum	1		

	SUBTOTAL CARRIED FORWARD TO SUMMARY			
D	<u>MINI VARIABLE REFRIDGERANT FLOW (VRF)</u>			
D1	Supply, Install and Delivery of Mini VRF air conditioning system complete with indoor and outdoor units. Including decorative panel, piping between indoor and outdoor portions of unit, mounting brackets, condensate drain pumps and all necessary accessories.			
	Indoor Unit			
	Brand: Midea, LG, Daikin, Samsung or similar approved			
	Type: Midwall			
	Supply Code:			
D2	Cooling Capacity: 12 000 BTU	No	2	
	Cooling only			
	Inverter Type			
	Controller: Wired			
	Drainage including condensate pump			
	Include all necessary supports, controllers and ancillaries			
	Outdoor Unit			
	Brand: Midea, LG, Daikin, Samsung or similar approved			
	Cooling Capacity: 36 000 BTU			
	Heat Pump			
D3	Inverter Type	No	1	
	Bluchem corrosion protection to be applied			
	Controller: BMS			
	Include all necessary supports, controllers and ancillaries			
D4	Complete piping installation including but not limited to piping, junction boxes, cable trays. Length of piping measured per running meter of cable tray/rack, this could include 2 pipe systems. (Supply and return)	m	60	
D5	Installation and commissioning	No	1	

	SUBTOTAL CARRIED FORWARD TO SUMMARY				
	<u>MECHANICAL INSTALLATION</u>				
E	<u>SUMMARY</u>				
E1	PRELIMINARY AND GENERAL			-----	
E2	EXTRAS NOT LISTED			-----	
E3	MINI VARIABLE REFRIDGERANT FLOW (VRF)			-----	
E4					
	TOTAL			-----	
	ADD VAT (15%)				
	GRAND TOTAL				