

**Transnet Port Terminal**

an Operating Division of **TRANSNET SOC LTD**

[hereinafter referred to as **Transnet**]

[Registration No. 1990/000900/30]

REQUEST FOR PROPOSAL [RFP] GOODS

FOR THE PROVISION OF SERVICE TO SUPPLY AND DELIVER CONVEYOR CARRYING IDLERS AND RETURN-IDLER ASSEMBLIES FOR A ONCE OFF PERIOD

RFP NUMBER	TPT/2024/02/0030/56812/RFP
ISSUE DATE:	10 April 2024
COMPULSORY SITE BRIEFING DATE:	19 April 2024 via Ms Teams, 11:30am
CLOSING DATE:	30 April 2024
CLOSING TIME:	12:00 PM
BID VALIDITY PERIOD:	180 Business Days from Closing Date

Note to the bidders:

Bidders are required to ensure that electronic bid submissions are done at least a day before the closing date to prevent issues which they may encounter due to their internet speed, bandwidth or the size of the number of uploads they are submitting. Transnet will not be held liable for any challenges experienced by bidders as a result of the technical challenges. Please do not wait for the last hour to submit. A Bidder can upload 30mb per upload and multiple uploads are permitted.

SCHEDULE OF BID DOCUMENTS

Section No	Page
SECTION 1: SBD1 FORM.....	3
SECTION 2 : NOTICE TO BIDDERS	5
1 INVITATION TO BID.....	5
2 FORMAL BRIEFING.....	6
3 PROPOSAL SUBMISSION.....	6
4 RFP INSTRUCTIONS	7
5 JOINT VENTURES OR CONSORTIUMS	7
6 COMMUNICATION	7
7 CONFIDENTIALITY	8
8 COMPLIANCE	8
9 EMPLOYMENT EQUITY ACT.....	8
10 DISCLAIMERS	8
11 LEGAL REVIEW	9
12 SECURITY CLEARANCE	9
13 NATIONAL TREASURY'S CENTRAL SUPPLIER DATABASE.....	10
14 TAX COMPLIANCE	10
SECTION 3: BACKGROUND, OVERVIEW AND SCOPE OF REQUIREMENTS	12
SECTION 4: PRICING AND DELIVERY SCHEDULE	19
SECTION 5: PROPOSAL FORM AND LIST OF RETURNABLE DOCUMENTS.....	41
SECTION 6: CERTIFICATE OF ACQUAINTANCE WITH RFP, MASTER AGREEMENT & APPLICABLE DOCUMENTS.....	46
SECTION 7: RFP DECLARATION AND BREACH OF LAW FORM.....	47
SECTION 8: RFP CLARIFICATION REQUEST FORM.....	52
SECTION 9 : SPECIFIC GOALS POINTS CLAIM FORM	53
SECTION 10: CERTIFICATE OF ATTENDANCE OF COMPULSORY	60

_Toc104996848

RFP ANNEXURES:

ANNEXURE A: SCOPE OF WORK(SOW)

ANNEXURE B:SDB 6.2 DECLARATION CERTIFICATE FOR LOCAL PRODUCTION AND CONTENT

ANNEXURE C: LOCAL CONTENT DECLARATION SUMMARY SCHEDULE

ANNEXURE D: IMPORTED CONTENT DECLARATION

ANNEXURE E: DECLARATION – SUPPORTING SCHEDULE TO ANNEX C

ANNEXURE F: SPECIFICATIONS /DRAWINGS

ANNEXURE G: MASTER AGREEMENT

ANNEXURE H: TRANSNET'S GENERAL BID CONDITIONS

ANNEXURE I: TRANSNET'S SUPPLIER INTEGRITY PACT

ANNEXURE J: NON-DISCLOSURE AGREEMENT

**RFP FOR THE PROVISION OF
OF SERVICE TO SUPPLY AND DELIVER CONVEYOR CARRYING IDLERS AND RETURN-IDLER
ASSEMBLIES ON AN AS AND WHEN REQUIRED BASIS FOR A ONCE OFF PERIOD**

SECTION 1: SBD1 FORM

PART A
INVITATION TO BID

YOU ARE HEREBY INVITED TO BID FOR REQUIREMENTS OF SUPPLY AND DELIVER CONVEYOR CARRYING IDLERS AND RETURN-IDLER ASSEMBLIES ON AN AS AND WHEN REQUIRED BASIS, A DIVISION TRANSNET SOC LTD							
BID NUMBER:	TPT/2024/02/0030/56812/RFP	ISSUE DATE:	10-04-2024	CLOSING DATE:	30-04-2024	CLOSING TIME:	12:00 pm
DESCRIPTION	RFP FOR THE PROVISION OF SERVICE TO SUPPLY AND DELIVER CONVEYOR CARRYING IDLERS AND RETURN-IDLER ASSEMBLIES FOR A ONCE OFF PERIOD						
BID RESPONSE DOCUMENTS SUBMISSION							
RESPONDENTS ARE TO UPLOAD THEIR BID RESPONSE PROPOSALS ONTO THE TRANSNET SYSTEM AGAINST EACH TENDER SELECTED (<i>please refer to section 2, paragraph 3 for a detailed process on how to upload submissions</i>): https://transnetetenders.azurewebsites.net							
BIDDING PROCEDURE ENQUIRIES MAY BE DIRECTED TO							
CONTACT PERSON	Thizeka Mpengezi						
TELEPHONE NUMBER	021 449 3169						
FACSIMILE NUMBER	N/A						
E-MAIL ADDRESS	Thizeka.mpengezi@transnet.net						
SUPPLIER INFORMATION							
NAME OF BIDDER							
POSTAL ADDRESS							
STREET ADDRESS							
TELEPHONE NUMBER	CODE			NUMBER			
CELLPHONE NUMBER							
FACSIMILE NUMBER	CODE			NUMBER			
E-MAIL ADDRESS							
VAT REGISTRATION NUMBER							
SUPPLIER COMPLIANCE STATUS	TAX COMPLIANCE SYSTEM PIN:			OR	CENTRAL SUPPLIER DATABASE	UNIQUE REGISTRATION REFERENCE NUMBER:	MAAA
B-BBEE STATUS LEVEL VERIFICATION CERTIFICATE	TICK APPLICABLE BOX] <input type="checkbox"/> Yes <input type="checkbox"/> No			B-BBEE STATUS LEVEL SWORN AFFIDAVIT		[TICK APPLICABLE BOX] <input type="checkbox"/> Yes <input type="checkbox"/> No	

Respondent's Signature

Date & Company Stamp

[A B-BBEE STATUS LEVEL VERIFICATION CERTIFICATE/ SWORN AFFIDAVIT (FOR EMES & QSEs) MUST BE SUBMITTED FOR PURPOSES OF COMPLIANCE WITH THE B-BBEE ACT]			
1 ARE YOU THE ACCREDITED REPRESENTATIVE IN SOUTH AFRICA FOR THE GOODS /SERVICES /WORKS OFFERED?	<input type="checkbox"/> Yes <input type="checkbox"/> No [IF YES ENCLOSE PROOF]	2 ARE YOU A FOREIGN BASED SUPPLIER FOR THE GOODS /SERVICES /WORKS OFFERED?	<input type="checkbox"/> Yes <input type="checkbox"/> No [IF YES, ANSWER QUESTIONNAIRE BELOW]
QUESTIONNAIRE TO BIDDING FOREIGN SUPPLIERS			
IS THE ENTITY A RESIDENT OF THE REPUBLIC OF SOUTH AFRICA (RSA)?		<input type="checkbox"/> YES <input type="checkbox"/> NO	
DOES THE ENTITY HAVE A BRANCH IN THE RSA?		<input type="checkbox"/> YES <input type="checkbox"/> NO	
DOES THE ENTITY HAVE A PERMANENT ESTABLISHMENT IN THE RSA?		<input type="checkbox"/> YES <input type="checkbox"/> NO	
DOES THE ENTITY HAVE ANY SOURCE OF INCOME IN THE RSA?		<input type="checkbox"/> YES <input type="checkbox"/> NO	
IS THE ENTITY LIABLE IN THE RSA FOR ANY FORM OF TAXATION?		<input type="checkbox"/> YES <input type="checkbox"/> NO	
IF THE ANSWER IS "NO" TO ALL OF THE ABOVE, THEN IT IS NOT A REQUIREMENT TO REGISTER FOR A TAX COMPLIANCE STATUS SYSTEM PIN CODE FROM THE SOUTH AFRICAN REVENUE SERVICE (SARS) AND IF NOT REGISTER AS PER 1.3 BELOW.			

PART B TERMS AND CONDITIONS FOR BIDDING

1. TAX COMPLIANCE REQUIREMENTS
1.1 BIDDERS MUST ENSURE COMPLIANCE WITH THEIR TAX OBLIGATIONS. 1.2 BIDDERS ARE REQUIRED TO SUBMIT THEIR UNIQUE PERSONAL IDENTIFICATION NUMBER (PIN) ISSUED BY SARS TO ENABLE THE ORGAN OF STATE TO VERIFY THE TAXPAYER'S PROFILE AND TAX STATUS. 1.3 APPLICATION FOR TAX COMPLIANCE STATUS (TCS) PIN MAY BE MADE VIA E-FILING THROUGH THE SARS WEBSITE WWW.SARS.GOV.ZA. 1.4 BIDDERS MAY ALSO SUBMIT A PRINTED TCS CERTIFICATE TOGETHER WITH THE BID. 1.5 IN BIDS WHERE UNINCORPORATED CONSORTIA / JOINT VENTURES / SUB-CONTRACTORS ARE INVOLVED, EACH PARTY MUST SUBMIT A SEPARATE TCS CERTIFICATE / PIN / CSD NUMBER. 1.6 WHERE NO TCS IS AVAILABLE BUT THE BIDDER IS REGISTERED ON THE CENTRAL SUPPLIER DATABASE (CSD), A CSD NUMBER MUST BE PROVIDED.

NB: FAILURE TO PROVIDE / OR COMPLY WITH ANY OF THE ABOVE PARTICULARS MAY RENDER THE BID INVALID.

SIGNATURE OF BIDDER:

.....

CAPACITY UNDER WHICH THIS BID IS SIGNED:

.....

(Proof of authority must be submitted e.g. company resolution)

DATE: _____

Respondent's Signature

Date & Company Stamp

SECTION 2 : NOTICE TO BIDDERS

1 INVITATION TO BID

Responses to this RFP [hereinafter referred to as a **Bid** or a **Proposal**] are requested from persons, companies, close corporations or enterprises [hereinafter referred to as an **entity, Respondent** or **Bidder**].

DESCRIPTION	RFP FOR THE PROVISION OF SERVICE TO SUPPLY AND DELIVER CONVEYOR CARRYING IDLERS AND RETURN-IDLER ASSEMBLIES FOR A ONCE OFF PERIOD [the Goods]
TENDER ADVERT	All Transnet tenders are advertised on the National Treasury's e-Tender Publication Portal and the Transnet website. Should one of these media (i.e. National Treasury's e-Tender Publication Portal or Transnet website) not be available, bidders are advised to check on the other media for advertised tenders.
RFP DOWNLOADING	<p>This RFP may be downloaded directly from National Treasury's e-Tender Publication Portal at www.etenders.gov.za free of charge.</p> <p>To download RFP and Annexures:</p> <ul style="list-style-type: none"> • Click on "Tender Opportunities"; • Select "Advertised Tenders"; • In the "Department" box, select Transnet SOC Ltd. <p>Once the tender has been in the list, click on the "Tender documents" tab and process to download all uploaded documents.</p> <p>The RFP may also be downloaded from the Transnet Portal at https://transnetetenders.azurewebsites.net (please use Google Chrome to access Transnet link/site) free of charge (<i>refer to section 2, paragraph 3 below for detailed steps</i>)</p>
COMMUNICATION	<p>Transnet will publish the outcome of this RFP on the National Treasury e-tender portal and Transnet website with 10 days after the award has been finalised. All unsuccessful bidders have a right to request for reasons for their bid not being successful. This requested must be directed to the contact person stated in the SBD 1 form</p> <p>Any addenda to the RFP or clarifications will be published on the e-tender portal and Transnet website. Bidders are required to check the e-tender portal or Transnet website prior to finalising their bid submissions for any changes or clarifications to the RFP.</p> <p>Transnet will not be held liable if Bidders do not receive the latest information regarding this RFP with the possible consequence of either being disadvantaged or disqualified as a result thereof.</p>
BRIEFING SESSION	<p>COMPULSORY</p> <p>Bidders are required to confirm their attendance and to send their contact details including the number of representatives (where applicable) to the following address: Thizeka.mpengezi@transnet.net</p> <p>This is to ensure that Transnet may make the necessary arrangements for the briefing session.</p> <p>Refer to paragraph 2 for details.</p>
CLOSING DATE	<p>12:00 pm on Tuesday 30 April 2024</p> <p>Bidders must ensure that bids are uploaded timeously onto the system. Generally, if a bid is late, it will not be accepted for consideration.</p>

	<i>Bidders are required to ensure that electronic bid submissions are done at least a day before the closing date to prevent issues which they may encounter due to their internet speed, bandwidth or the size of the number of uploads they are submitting. Transnet will not be</i>
VALIDITY PERIOD	<p>180 Business Days from Closing Date</p> <p>Bidders are to note that they may be requested to extend the validity period of their bid, at the same terms and conditions, if the internal evaluation process has not been finalised within the validity period. However, once the adjudication body has approved the process and award of the business to the successful bidder(s), the validity of the successful bidder(s)' bid will be deemed to remain valid until a final contract has been concluded.</p> <p>Should a bidder fail to respond to a request for extension of the validity period before it expires, that bidder will be excluded from tender process.</p> <p>With regard to the validity period of next highest ranked bidders, please refer to Section 2.</p>

Any additional information or clarification will be published on the e-Tender portal and Transnet website, if necessary.

2 FORMAL BRIEFING

A compulsory site meeting and/or RFP briefing will be conducted virtually via Ms Teams on the **19 of April 2024** for a period of ± 2 hours. [Respondents to provide own transportation and accommodation]. The briefing session will start punctually and information will not be repeated for the benefit of Respondents arriving late.

- 2.1 *A Certificate of Attendance in the form set out in Section 10 hereto must be completed and submitted with your Proposal as proof of attendance is required for a **compulsory** site meeting and/or RFP briefing.*
- 2.2 Respondents failing to attend the compulsory RFP briefing will be disqualified.

3 PROPOSAL SUBMISSION

Transnet has implemented a new electronic tender submission system, the e-Tender Submission Portal, in line with the overall Transnet digitalization strategy where suppliers can view advertised tenders, register their information, log their intent to respond to bids and upload their bid proposals/responses on to the system.

- a) The Transnet e-Tender Submission Portal can be accessed as follows:
 - Log on to the Transnet eTenders management platform website/ Portal (transnetetenders.azurewebsites.net) Please use **Google Chrome** to access Transnet link/site);
 - Click on "ADVERTISED TENDERS" to view advertised tenders;
 - Click on "SIGN IN/REGISTER – for bidder to register their information (must fill in all mandatory information);
 - Click on "SIGN IN/REGISTER" - to sign in if already registered;
 - Toggle (click to switch) the "Log an Intent" button to submit a bid;
 - Submit bid documents by uploading them into the system against each tender selected.
 - No late submissions will be accepted. The bidder guide can be found on the Transnet Portal transnetetenders.azurewebsites.net

4 RFP INSTRUCTIONS

- 4.1 Please sign documents [sign, stamp and date the bottom of each page] before uploading them on the system. The person or persons signing the submission must be legally authorised by the respondent to do so.
- 4.2 **All returnable documents tabled in the Proposal Form [Section 5] must be returned with proposals.**
- 4.3 Unless otherwise expressly stated, all Proposals furnished pursuant to this RFP shall be deemed to be offers. Any exceptions to this statement must be clearly and specifically indicated.
- 4.4 Any additional conditions must be embodied in an accompanying letter. Subject only to clause 15 [Alterations made by the Respondent to Bid Prices] of the General Bid Conditions, paragraph 12 below (Legal Review) and Section 6 of the RFP, alterations, additions or deletions must not be made by the Respondent to the actual RFP documents.

5 JOINT VENTURES OR CONSORTIUMS

Respondents who would wish to respond to this RFP as a Joint Venture [**JV**] or consortium with B-BBEE entities, must state their intention to do so in their RFP submission. Such Respondents must also submit a signed JV or consortium agreement between the parties clearly stating the percentage [%] split of business and the associated responsibilities of each party. If at the time of the bid submission such a JV or consortium agreement has not been concluded, the partners must submit confirmation in writing of their intention to enter into a JV or consortium agreement should they be awarded business by Transnet through this RFP process. This written confirmation must clearly indicate the percentage [%] split of business and the responsibilities of each party. In such cases, award of business will only take place once a signed copy of a JV or consortium agreement is submitted to Transnet.

- Respondents are to note that for the purpose of Evaluation, a JV will be evaluated based on one consolidated B-BBEE score card (a consolidated B-BBEE Status Level verification certificate) Preference points will be awarded to a bidder for attaining the specific goals requirements in accordance with the table indicated in Section 4.1 of the specific goals Claim Form.

COMMUNICATION

- 5.1 For specific queries relating to this RFP, an RFP Clarification Request Form should be submitted onto the system and to [**thizeka.mpengezi@transnet.net**] before **12:00 pm on 25 April 2024**, substantially in the form set out in Section 8 hereto. In the interest of fairness and

transparency, Transnet's response to such a query will be published on the e-tender portal and Transnet website.

- 5.2 After the closing date of the RFP, a Respondent may only communicate with the Verlyn Johnson(Verlynn.Johnson@transnet.net) at telephone number 021 449 2552, on any matter relating to its RFP Proposal.
- 5.3 Respondents are to note that changes to its submission will not be considered after the closing date.
- 5.4 It is prohibited for Respondents to attempt, either directly or indirectly, to canvass any officer or employee of Transnet in respect of this RFP between the closing date and the date of the award of the business.
- 5.5 Respondents found to be in collusion with one another will be automatically disqualified and restricted from doing business with organs of state for a specified period.
- 5.6 Transnet will publish the outcome of this RFP in the National Treasury e-tender portal and Transnet website with 10 days after the award has been finalised. Respondents are required to check the National Treasury e-tender Portal and Transnet website for the results of the tender process. All unsuccessful bidders have a right to request Transnet to furnish individual reasons for their bid not being successful. This requested must be directed to the contact person stated in the SBD 1 form

6 CONFIDENTIALITY

All information related to this RFP is to be treated with strict confidence. In this regard Respondents are required to certify that they have acquainted themselves with the Non-Disclosure Agreement. All information related to a subsequent contract, both during and after completion thereof, will be treated with strict confidence. Should the need however arise to divulge any information related to this RFP or the subsequent contract, written approval must be obtained from Transnet.

7 COMPLIANCE

The successful Respondent [hereinafter referred to as the Service provider shall be in full and complete compliance with any and all applicable laws and regulations.

8 EMPLOYMENT EQUITY ACT

Respondents must comply with the requirements of the Employment Equity Act 55 of 1998 applicable to it including (but not limited to) Section 53 of the Employment Equity Act.

9 DISCLAIMERS

Respondents are hereby advised that Transnet is not committed to any course of action as a result of its issuance of this RFP and/or its receipt of Proposals. In particular, please note that Transnet reserves the right to:

- 9.1 modify the RFP's services request Respondents to re-bid on any such changes;
- 9.2 reject any Proposal that does not conform to instructions and specifications which are detailed herein;
- 9.3 disqualify Proposals submitted after the stated submission deadline [closing date];
- 9.4 award a contract in connection with this Proposal at any time after the RFP's closing date;

- 9.5 award a contract for only a portion of the proposed Services which are reflected in the scope of this RFP;
- 9.6 split the award of the contract between more than one Supplier, should it at Transnet's discretion be more advantageous in terms of, amongst others, cost or developmental considerations;
- 9.7 cancel the bid process;
- 9.8 validate any information submitted by Respondents in response to this bid. This would include, but is not limited to, requesting the Respondents to provide supporting evidence. By submitting a bid, Respondents hereby irrevocably grant the necessary consent to Transnet to do so;
- 9.9 request audited financial statements or other documentation for the purposes of a due diligence exercise;
- 9.10 not accept any changes or purported changes by the Respondent to the bid rates after the closing date and/or after the award of the business, unless the contract specifically provided for it;
- 9.11 to cancel the contract and/request that National Treasury place the Respondent on its Database of Restricted Suppliers for a period not exceeding 10 years, on the basis that a contract was awarded on the strength of incorrect information furnished by the Respondent or on any other basis recognised in law;
- 9.12 to award the business to the next ranked bidder, provided that he/she is still prepared to provide the required Goods at the quoted price, should the preferred bidder fail to sign or commence with the contract within a reasonable period after being requested to do so. Under such circumstances, the validity of the bids of the next ranked bidder(s) will be deemed to remain valid, irrespective of whether the outcome of the tender has been published the outcome of the bid process on the National Treasury e-tender Portal and Transnet website. Bidders may therefore be requested to advise whether they would still be prepared to provide the required Goods at their quoted price.

Note that Transnet will not reimburse any Respondent for any preparatory costs or other work performed in connection with its Proposal, whether or not the Respondent is awarded a contract.

10 LEGAL REVIEW

A Proposal submitted by a Respondent will be subjected to review and acceptance or rejection of its proposed contractual terms and conditions by Transnet's Legal Counsel, prior to consideration for an award of business. A material deviation from the Standard terms or conditions could result in disqualification.

11 SECURITY CLEARANCE

Acceptance of this bid could be subject to the condition that the Successful Respondent, its personnel providing the Services and its subcontractor(s) must obtain security clearance from the appropriate authorities to the level of **CONFIDENTIAL/ SECRET/TOP SECRET**. Obtaining the required clearance is the responsibility of the Successful Respondent. Acceptance of the bid is also subject to the condition that the Successful Respondent will implement all such security measures as the safe performance of the contract may require.

12 NATIONAL TREASURY'S CENTRAL SUPPLIER DATABASE

Respondents are required to self-register on National Treasury's Central Supplier Database (CSD) which has been established to centrally administer supplier information for all organs of state and facilitate the verification of certain key supplier information. Respondents must register on the CSD prior to submitting their bids. Business may not be awarded to a Respondent who has failed to register on the CSD. Only foreign suppliers with no local registered entity need not register on the CSD.

For this purpose, the attached SBD 1 form must be completed and submitted as a mandatory returnable document by the closing date and time of the bid.

13 TAX COMPLIANCE

Respondents must be compliant when submitting a proposal to Transnet and remain compliant for the entire contract term with all applicable tax legislation, including but not limited to the Income Tax Act, 1962 (Act No. 58 of 1962) and Value Added Tax Act, 1991 (Act No. 89 of 1991).

It is a condition of this bid that the tax matters of the successful Respondents be in order, or that satisfactory arrangements have been made with South African Revenue Service (SARS) to meet the Respondents tax obligations.

The Tax Compliance status requirements are also applicable to foreign Respondents/ individuals who wish to submit bids.

Where Consortia / Joint Ventures / Sub-contractors are involved, each party must be registered on the Central Supplier Database and their tax compliance status will be verified through the Central Supplier Database.

**Transnet urges its clients, suppliers and the general public to report any fraud or corruption to
TIP-OFFS ANONYMOUS:**



Ethics Helpdesk (Pty) LTD.
Ethics Management System™

You can choose to be **Anonymous or Non-Anonymous on ANY** of the platforms
PLEASE RETAIN YOUR REFERENCE NUMBER



AI Voice Bot "Jack"

Speak to our AI Voice Chat Bot "JACK", you converse with him like chatting to a human, with the option to record a message and speak to an agent at anytime.

What's App

Speak to an Agent via What's App.

Speak to an Agent

Speak to an Agent via the platform with no call or data charge

Telegram

Speak to an Agent via Telegram



0800 003 056



086 551 4153



reportit@ethicshelpdesk.com



***120*0785980808#**

SECTION 3: BACKGROUND, OVERVIEW AND SCOPE OF REQUIREMENTS

1 BACKGROUND

TPT require the services of a service provider with the knowledge and capabilities to supply and deliver conveyor idlers and idler assemblies to the Iron Ore Terminal (hereafter IOT) for a once off period.

EXECUTIVE OVERVIEW

Whereas Transnet is seeking a partner(s) to provide solutions for its port terminals nationally, it also seeks to improve its current processes for providing these Services to its end user community throughout its locations.

The selected Supplier must share in the mission and business objectives of Transnet. These mutual goals will be met by meeting contractual requirements and new challenges in an environment of teamwork, joint participation, flexibility, innovation and open communications. In this spirit of partnership, Transnet and its Supplier will study the current ways they do business to enhance current practices and support processes and systems. Such a partnership will allow Transnet to reach higher levels of quality, service and profitability.

Specifically, Transnet seeks to benefit from this partnership in the following ways:

- 1.1 Transnet must receive reduced cost of acquisition and improved service benefits resulting from the Supplier's economies of scale and streamlined service processes.
- 1.2 Transnet must achieve appropriate availability that meets user needs while reducing costs for both Transnet and the chosen Supplier(s).
- 1.3 Transnet must receive proactive improvements from the Supplier with respect to supply/provision of Services and related processes.
- 1.4 Transnet's overall competitive advantage must be strengthened by the chosen Supplier's leading edge technology and service delivery systems.
- 1.5 Transnet end users must be able to rely on the chosen Supplier's personnel for service enquiries, recommendations and substitutions.
- 1.6 Transnet must reduce costs by streamlining its acquisition of Goods/Services, including managed service processes on a Group basis.

2 SCOPE OF REQUIREMENTS

- 2.1 Refer to Annexure A

3 GREEN ECONOMY / CARBON FOOTPRINT

Transnet wishes to have an understanding of your company's position with regard to environmental commitments, including key environmental characteristics such as waste disposal, recycling and energy conservation. *Please submit details of your entity's policies in this regard.*

4 GENERAL SUPPLIER OBLIGATIONS

- 4.1 The Service provider(s) shall be fully responsible to Transnet for the acts and omissions of persons directly or indirectly employed by them.

4.2 The Service provider(s) must comply with the requirements stated in this RFP.

5 EVALUATION METHODOLOGY

Transnet will utilise the following methodology and criteria in selecting a preferred Supplier:

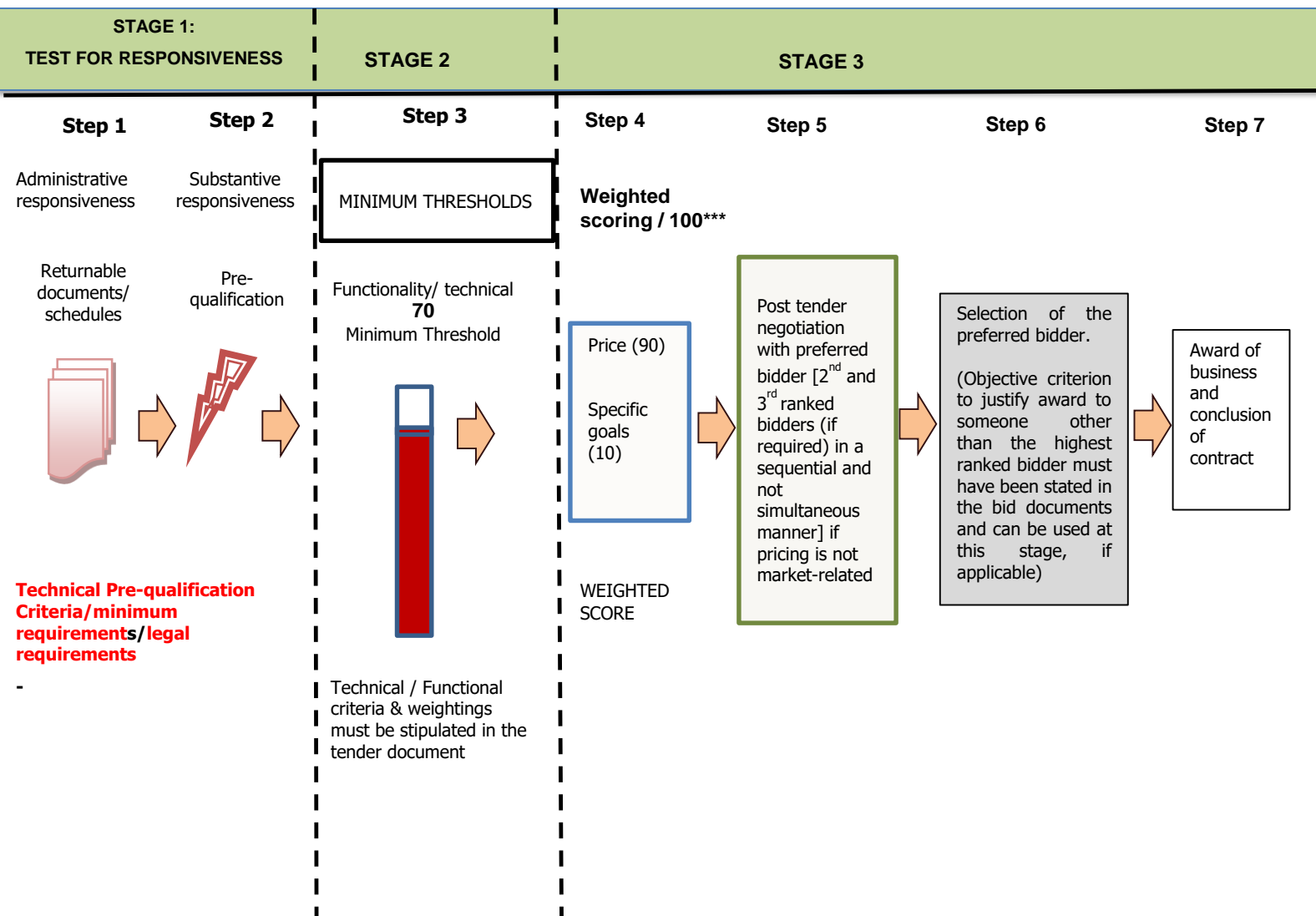

NB: Evaluation of the various stages will normally take place in a sequential manner. However, in order to expedite the process, Transnet reserves the right to conduct the different steps of the evaluation process in parallel. In such instances the evaluation of bidders at any given stage must not be interpreted to mean that bidders have necessarily passed any previous stage(s).

5.1 STEP ONE: Test for Administrative Responsiveness

The test for administrative responsiveness will include the following:

Administrative responsiveness check	RFP Reference
<ul style="list-style-type: none"> Whether the Bid has been lodged on time 	Section 1 paragraph 3
<ul style="list-style-type: none"> Whether all Returnable Documents and/or schedules [where applicable] were completed and returned by the closing date and time 	Section 5

Respondent's Signature

Date & Company Stamp

<ul style="list-style-type: none"> Verify the validity of all returnable documents 	<i>Section 5</i>
<ul style="list-style-type: none"> Verify if the Bid document has been duly signed by the authorised respondent 	<i>All sections</i>

The test for administrative responsiveness [Step One] must be passed for a Respondent's Proposal to progress to Step Two for further pre-qualification

5.2 STEP TWO: Test for Substantive Responsiveness to RFP

The test for substantive responsiveness to this RFP will include the following:

Check for substantive responsiveness	RFP Reference
<ul style="list-style-type: none"> Whether any general and legislation qualification criteria set by Transnet, have been met 	<i>All sections including: Section 2 paragraphs, 2.2, 6, 11.2, General Bid Conditions clause 20</i>
<ul style="list-style-type: none"> Whether the Bid contains a priced offer as prescribed in the pricing and delivery schedule 	<i>Section 4</i>
<ul style="list-style-type: none"> Whether the Bid materially complies with the scope and/or specification given 	<i>All Sections</i>
<ul style="list-style-type: none"> Entity's financial stability 	

The test for substantive responsiveness [Step Two] must be passed for a Respondent's proposal to progress to Step Three for further evaluation

5.3 STEP THREE: Minimum Threshold 70 points for Technical Criteria

The test for the Technical and Functional threshold will include the following:

CONVEYOR IDLERS					
PROVISION OF SERVICE TO SUPPLY AND DELIVER CONVEYOR CARRYING IDLER ASSEMBLIES ON AS AND WHEN REQUIRED BASIS FOR A ONCE OFF PERIOD					
EVALUATION CRITERIA	DESCRIPTION	SCORING PRINCIPLE	RETURNABLE SCHEDULE	CRITERIA (YES/NO) MANDATORY CRITERIA	WEIGHT
COMPANY EXPERIENCE	The Service Provider shall have more than five (5) years cumulative experience in supplying of conveyor idlers in the last ten (10) years.	<p>35 points= Reference letters submitted from the Service Provider's clients indicating more than five (5) years cumulative experience in supplying of Conveyor Idlers</p> <p>25 points = Reference letters submitted from the Service Provider's clients indicating five (5) years cumulative experience in supplying of Conveyor Idlers</p> <p>15 points= Reference letters submitted from the Service Provider's clients indicating three (3) to less than five (5) years cumulative experience in supplying of Conveyor Idlers</p> <p>0 points = Reference letters submitted from the Service Provider's clients indicating less than three (3) years cumulative experience in supplying of Conveyor Idlers/No reference letters submitted</p>	Company Experience	N/A	35
MANUFACTURING STANDARDS	The Conveyor idles shall be manufactured as per SANS 1313-2:2012 quality standards	<p>35 points = Valid copy of a SANS 1313-1:2012 or SANS 1313-3:2012 permit submitted indicating the service provider's compliance to a manufacturing standard</p> <p>0 points = Invalid copy of a SANS 1313-1:2012 or SANS 1313-3:2012 permit submitted indicating the service provider's compliance to a manufacturing standard/No SANS permit submitted</p>	Manufacturing standards	N/A	35
GUARANTEE/WARRANTEE	The service provider shall guarantee the workmanship and quality for a period of more than twelve (12) months on the conveyor idlers post the installation.	<p>30 points = Guarantee/Warranty submitted of more than twelve (12) months on the workmanship and quality of the Conveyor Idlers post the installation</p> <p>20 points = Guarantee/Warranty submitted of twelve (12) months on the workmanship and quality of the Conveyor Idlers post the installation</p> <p>10 points = Guarantee/Warranty submitted of nine (9) months on the workmanship and quality of the Conveyor Idlers post the installation</p> <p>0 points = Guarantee/Warranty submitted of less than nine (9) months on the workmanship and quality of the Conveyor Idlers post the installation/No guarantee/warranty submitted</p>	Guarantee/Warrantee	N/A	30

Respondent's Signature

Date & Company Stamp

Respondents are to note that Transnet will round off final technical scores to the nearest 2 (two) decimal places for the purposes of determining whether the technical threshold has been met.

The minimum threshold for technical/functionality [Step Three] must be met or exceeded for a Respondent's Proposal to progress to Step Four for final evaluation

5.4 **STEP FOUR: Evaluation and Final Weighted Scoring**

a) **Price and TCO Criteria** [Weighted score 90 points]:

Evaluation Criteria	RFP Reference
• Commercial offer	<i>Section 4</i>

Transnet will utilise the following formula in its evaluation of Price:

$$PS = 90 \left(1 - \frac{Pt - P_{min}}{P_{min}} \right)$$

Where:

- Ps = Score for the Bid under consideration
- Pt = Price of Bid under consideration
- P_{min} = Price of lowest acceptable Bid

$$\text{OR } PS = 90 \left(1 + \frac{Pt - P_{max}}{P_{max}} \right)$$

Where:

- Ps = Points scored for the price of Bid under consideration
- Pt = Price of Bid under consideration
- P_{max} = Price of highest acceptable Bid

b) **Specific Goals** [Weighted score 10 point]

- Specific goals preference points claim form
- Preference points will be awarded to a bidder for attaining the specific goals requirements in accordance with the table indicated in Section 4.1 of the specific goals Claim Form.

5.5 **SUMMARY: Applicable Thresholds and Final Evaluated Weightings**

Thresholds	Minimum Threshold
Technical / functionality	70

Evaluation Criteria	Final Weighted Scores
Price and Total Cost of Ownership	90
Specific goals - Scorecard	10
TOTAL SCORE:	100

5.6 **STEP FIVE: Post Tender Negotiations (if applicable)**

- Respondents are to note that Transnet may not award a contract if the price offered is not market-related. In this regard, Transnet reserves the right to engage in PTN

with the view to achieving a market-related price or to cancel the tender.

Negotiations will be done in a sequential manner i.e.:

- first negotiate with the highest ranked bidder or cancel the bid, should such negotiations fail,
 - negotiate with the 2nd and 3rd ranked bidders (if required) in a sequential manner.
- In the event of any Respondent being notified of such short-listed/preferred bidder status, his/her bid, as well as any subsequent negotiated best and final offers (BAFO), will automatically be deemed to remain valid during the negotiation period and until the ultimate award of business.
 - Should Transnet conduct post tender negotiations, Respondents will be requested to provide their best and final offers to Transnet based on such negotiations. Where a market related price has been achieved through negotiation, the contract will be awarded to the successful Respondent(s).

5.7 **STEP SIX: Objective Criteria (if applicable)**

Transnet reserves the right to award the business to the highest scoring bidder/s unless objective criteria justify the award to another bidder. The objective criteria Transnet may apply in this bid process include:

- Skills Transfer and Capacity Building for Transnet;
- Impact on Transnet's Return On Investment;
- To enhance the supplier development programme and local market.
- Rotation of Suppliers to promote opportunities for other suppliers, by overlooking a supplier that has been awarded business repeatedly overtime in order to benefit other suppliers in the market;
- If the business needs has changed resulting in a shorter lead time than advertised.
- To overlook the recommended supplier if it has a history of non-delivery.

The tenderer:

- is not under restrictions, or has principals who are under restrictions, preventing participating in the employer's procurement,
- is not undergoing a process of being restricted by Transnet or other state institution that Transnet may be aware of,
- can, as necessary and in relation to the proposed contract, demonstrate that he or she possesses the professional and technical qualifications, professional and technical competence, financial resources, equipment and other physical facilities, managerial capability, reliability, experience and reputation, expertise and the personnel, to perform the contract,
- has the legal capacity to enter into the contract
- is not insolvent, in receivership, under Business Rescue as provided for in chapter 6 of the Companies Act, 2008, bankrupt or being wound up, has his affairs administered by a court or a judicial officer, has suspended his business activities, or is subject to legal proceedings in respect of any of the foregoing,

- complies with the legal requirements, if any, stated in the tender data and
- is able, in the option of the employer to perform the contract free of conflicts of interest.

5.8 STEP SEVEN: Award of business and conclusion of contract

- Immediately after approval to award the contract has been received, the successful bidder(s) will be informed of the acceptance of his/their Bid by way of a Letter of Award. Thereafter the final contract will be concluded with the successful Respondent(s).
- A final contract will be concluded and entered into with the successful Bidder at the acceptance of a letter of award by the Respondent.

Respondent's Signature

Date & Company Stamp

SECTION 4: PRICING AND DELIVERY SCHEDULE

Respondents are required to complete the table below:

Respondent's Signature

Date & Company Stamp

PRICING SCHEDULE FOR PROVISION OF SERVICE TO SUPPLY AND DELIVER CONVEYOR CARRYING IDLERS AND RETURN-IDLER ASSEMBLIES AS A ONCE OFF PURCHASE AT SALDANHA IRON ORE TERMINAL

MM No.	Type	Short Description	Long Description	Drawing No.	Estimated Quantities	Unit of Measure	Price per Unit (Excl. of VAT)	Total Price for Estimated Quantity (Excl. of VAT)
130183	Carrying Idler	Carrying Idler 370mm Roll Face	Conveyor Carrying Idler	A3SBH2132	4500	Each		
			Type: Carrying Through Idler - Fixed					
			Idler Diameter: 152mm					
			Shaft Diameter: 30mm (Series 30)					
			Overall Shaft Length: 417mm					
			Belt Width: 1650					
			Func.Loc.: S/L 1&2, S/R 1-3					
			Drawing No.: A3SBH2132					
131074	Carrying Idler	Carrying Idler 400mm Roll Face	Conveyor Carrying Idler	A3SBH2141	3000	Each		
			Type: Carrying Through Idler - Fixed					
			Idler Diameter: 34mm					
			Overall Shaft Length: 444mm					
			Belt Width: 1650					
			Func.Loc.: S/R 1-3					
			Drawing No.: A3SBH2141					

Respondent's Signature

Date & Company Stamp

134970	Carrying Idler	Carrying Idler 160mm Roll Face	Conveyor Carrying Idler	BTS 030	300	Each		
			Type: Steel Impact Carrying Idler					
			Idler Diameter: 152mm					
			Shaft Diameter: 30mm (Series 30)					
			Overall Shaft Length: 207mm					
			Belt Width: 1650					
			Func.Loc.: CV 109					
			Drawing No.: BTS 030					
138505	Carrying Idler	Carrying Idler 600mm Roll Face	Conveyor Carrying Idler	BTS 011	450	Each		
			Type: Through, Retractable, Training, & Rigid Suspended Idler					
			Idler Diameter: 152mm					
			Shaft Diameter: 30mm (Series 30)					
			Overall Shaft Length: 647mm					
			Belt Width: 1650					
			Func.Loc.:					
			Drawing No.: BTS 011					
138509	Carrying Idler	Carrying Idler 610mm Roll Face	Conveyor Carrying Idler	BTS 010 (Sheet 1 & 2)	300	Each		
			Type: Garland Carrying Idler String - Quick Release Brackets					
			Idler Diameter: 178mm					
			Shaft Diameter: 40mm (Series 40)					
			Overall Shaft Length: 680mm					

			Belt Width: 1650					
			Func.Loc.:					
			Drawing No.: BTS 010 (Sheet 1 & 2)					
165856	Carrying Idler	Carrying Idler 340mm Roll Face	Conveyor Carrying Idler	BTS 031	450	Each		
			Type: Steel Impact Carrying Idler					
			Idler Diameter: 152mm					
			Shaft Diameter: 30mm (Series 30)					
			Overall Shaft Length: 387mm					
			Belt Width: 1650					
			Func.Loc.:					
			Drawing No.: BTS 031					
138513	Carrying Idler	Carrying Idler 660mm Roll Face	Conveyor Carrying Idler	BTS 012	600	Each		
			Type: Through, Retractable, Training, & Rigid Suspended Idler					
			Idler Diameter: 152mm					
			Shaft Diameter: 30mm (Series 30)					
			Overall Shaft Length: 707mm					
			Belt Width: 1650					
			Func.Loc.:					
			Drawing No.: BTS 012					
138512	Carrying Idler	Carrying Idler 610mm Roll Face	Conveyor Carrying Idler	BTS 009	12000	Each		
			Type: Through & Underslung Idler 45 degrees					

Respondent's Signature

Date & Company Stamp

			Idler Diameter: 178mm					
			Shaft Diameter: 40mm (Series 40)					
			Overall Shaft Length: 657mm					
			Belt Width: 1650					
			Func.Loc.:					
			Drawing No.: BTS 009					
130194	Carrying Idler	Carrying Idler 308mm Roll Face	Conveyor Carrying Idler	A3SBH2131	300	Each		
			Type: Carrying Idler - Garland					
			Idler Diameter: 152mm					
			Shaft Diameter: 30mm (Series 30)					
			Overall Shaft Length: 368mm					
			Belt Width: 1650					
			Func.Loc.: S/L 1&2					
			Drawing No.: A3SBH2131					
124772	Carrying Idler	HDPE Idler 370mm Roll Face	Conveyor Carrying Idler	BTS 040	90	Each		
			Type: Idler HDPE 370mm Roll Face					
			Idler Diameter: 152mm					
			Shaft Diameter: 30mm (Series 30)					
			Overall Shaft Length: 417mm					
			Belt Width: 1650					
			Func.Loc.: CV 114 Impact Station					
			Drawing No.: BTS 040					

Respondent's Signature

Date & Company Stamp

130231	Carrying Idler	Carrying Idler 370mm Roll Face	Conveyor Carrying Idler	A3SBH2136	400	Each		
			Type: Fixed Impact Carry Idler - Rubber					
			Idler Diameter: 159mm					
			Shaft Diameter: 30mm (Series 30)					
			Overall Shaft Length: 420mm					
			Belt Width: 1650					
			Func.Loc.: CV 114 Impact Station					
			Drawing No.: A3SBH2136					
131075	Carrying Idler	Carrying Idler 400mm Roll Face	Conveyor Carrying Idler	A3SBH2143	300	Each		
			Type: Fixed Impact Carry Idler - Rubber					
			Idler Diameter: 150mm					
			Shaft Diameter: 30mm (Series 30)					
			Overall Shaft Length: 448mm					
			Belt Width: 1800					
			Func.Loc.: S/R 1-3					
			Drawing No.: A3SBH2143					
131072	Carrying Idler	Carrying Idler 370mm Roll Face	Conveyor Carrying Idler	BTS 038	450	Each		
			Type: Rubber Carrying Idler 370 Roll Face					
			Idler Diameter: 150mm					
			Shaft Diameter: 30mm (Series 30)					

Respondent's Signature

Date & Company Stamp

			Overall Shaft Length: 418mm					
			Belt Width: 1650					
			Func.Loc.: S/R 1-3, Tripper Conveyor					
			Drawing No.: BTS 038					
118536	Carrying Idler	Carrying Idler 340mm Roll Face	Conveyor Carrying Idler	A3SBH2097	1200	Each		
			Type: Steel Balanced Carrying Roll - Fixed					
			Idler Diameter: 152mm					
			Shaft Diameter: 30mm (Series 30)					
			Overall Shaft Length: 366mm					
			Belt Width: 1650					
			Func.Loc.: Conveyor Scale					
			Drawing No.: A3SBH2097					
			Supply Balance Certificate					
134110	Carrying Idler	Scale Idler 400mm Roll Face	Conveyor Carrying Idler	BTS 036	300	Each		
			Type: Steel Balanced Scale Idler					
			Idler Diameter: 152mm					
			Shaft Diameter: 30mm (Series 30)					
			Overall Shaft Length: 434mm					
			Belt Width: 1800					
			Func.Loc.: S/R 1 - 3, Conveyor Scale					
			Drawing No.: BTS 036					
			Supply Balance Certificate					

Respondent's Signature

Date & Company Stamp

134123	Carrying Idler	Scale Idler 340mm Roll Face	Conveyor Carrying Idler	BTS 037	150	Each		
			Type: Steel Balanced Scale Idler					
			Idler Diameter: 152mm					
			Shaft Diameter: 30mm (Series 30)					
			Overall Shaft Length: 378mm					
			Belt Width: 1650					
			Func.Loc.: CV 209 Conveyor Scale					
			Drawing No.: BTS 037					
			Supply Balance Certificate					
141201	Carrying Idler	Scale Idler 340mm Roll Face	Conveyor Carrying Idler	SBHS 5040	600	Each		
			Type: Steel Balanced Scale Idler					
			Idler Diameter: 152mm					
			Shaft Diameter: 40mm (Series 40)					
			Overall Shaft Length: 697mm					
			Belt Width: 1800					
			Func.Loc.: S/R4 Boom Conveyor Scale					
			Drawing No.: SBHS 5040					
			Supply Balance Certificate					
131075	Carrying Idler	Rubber Impact Idler 400mm Roll Face	Conveyor Fixed Impact Carrying Idler - Rubber	A3 SBHS 2143	300	Each		
			Type: Rubber Impact Idler					
			Idler Diameter: 150mm					

Respondent's Signature

Date & Company Stamp

			Shaft Diameter: 30mm (Series 30)					
			Overall Shaft Length: 448mm					
			Belt Width: 1800					
			Func.Loc.: S/R1-3					
			Drawing No.: A3 SBHS 2143					
134110	Carrying Idler	Scale Idler	Conveyor Carrying Idler	BTS 036	300	Each		
			Type: Steel Balanced Scale Idler					
			Idler Diameter: 152mm					
			Shaft Diameter: 30mm (Series 30)					
			Overall Shaft Length: 434mm					
			Belt Width: 1800					
			Func.Loc.: S/R1-3					
			Drawing No.: BTS 036					
			Supply Balance Certificate					
145250	Carrying Idler	Carrying Idler 326mm Roll Face	Conveyor Carrying Idler		300	Each		
			Type: Impact Idler					
			Idler Diameter: 178mm					
			Shaft Diameter: 40mm (Series 40)					
			Overall Shaft Length: 387m					
145251	Carrying Idler	Carrying Idler 226mm Roll Face	Conveyor Carrying Idler		600	Each		
			Type: Rubber Impact Idler					
			Idler Diameter: 178mm					
			Shaft Diameter: 40mm (Series 40)					
			Overall Shaft Length: 287m					

			Belt Width: 1650					
			Func.Loc.: CV113 & CV213 tail; CV114 & CV214 tail					
118534	Carrying Idler	Carrying Idler 340mm Roll Face	Conveyor Carrying Idler	SBH 2112	150	Each		
			Type: Steel Idler					
			Idler Diameter: 152mm					
			Shaft Diameter: 50mm					
			Overall Shaft Length:					
			Belt Width: 1650					
			Func.Loc.:					
150542	Carrying Idler	Carrying Idler 270mm Roll Face	Conveyor Carrying Idler	BTS 073	90	Each		
			Type: Galvanised Steel Impact Idler					
			Idler Diameter: 150mm					
			Shaft Diameter: 30mm					
			Overall Shaft Length: 317					
			Belt Width:					
			Func.Loc.: CV314					
141201	Carrying Idler	Carrying Idler 660mm Roll Face	Conveyor Carrying Idler	SBHS 5040	60	Each		
			Type: Balanced Boom Scale Idler, 45 degrees					
			Idler Diameter: 152mm					
			Shaft Diameter:					
			Overall Shaft Length: 697mm					
			Belt Width: 1800					

Respondent's Signature

Date & Company Stamp

			Func.Loc.: S/R4 Boom Conveyor Scale					
			Drawing No.: SBHS 5040					
			Supply Balance Certificate					
151163	Self-trainer Idler	Carrying Idler 885mm Roll Face	Conveyor Self-trainer Idler		30	Each		
			Type: Polyurethane Idler					
			Idler Diameter: 152mm					
			Shaft Diameter: 30mm					
			Overall Shaft Length: 895mm					
			Belt Width:					
			Func.Loc.: Ship Loader Boom Conveyor					
151481	Carrying Idler	Rubber Impact Idler	Conveyor Carrying Idler		30	Each		
			Type: Rubber Impact Idler					
			Idler Diameter: 127mm					
			Shaft Diameter: 30mm					
			Overall Shaft Length: 414mm					
			Belt Width:					
			Func.Loc.: Ship Loader Boom Conveyor					
130230	Return Idler	Return Idler 1754mm Roll Face	Conveyor Return Idler	A3SBH2133	60	Each		
			Type: Flat Return Idler - 1 Roll					
			Idler Diameter: 152mm					
			Shaft Diameter: 40mm (Series 40)					
			Overall Shaft Length: 1799mm					

Respondent's Signature

Date & Company Stamp

			Belt Width: 1650					
			Func.Loc.: S/L 1&2					
			Drawing No.: A3SBH2133					
130192	Return Idler	Return Idler 885mm Roll Face	Conveyor Return Idler	A3SBH2134	180	Each		
			Type: Flat Return Idler - Fixed					
			Idler Diameter: 152mm					
			Shaft Diameter: 40 (Series 40)					
			Overall Shaft Length: 933mm					
			Belt Width: 1650					
			Func.Loc.: S/L 1&2					
			Drawing No.: A3SBH2134					
138510	Return Idler	Return Idler 885mm Roll Face	Conveyor Return Idler	BTS 017	600	Each		
			Type: Flat Return&V-Return Idler - S25-2Roll-1650BW					
			Idler Diameter: 152mm					
			Shaft Diameter: 25 (Series 25)					
			Overall Shaft Length: 929mm					
			Belt Width: 1650					
			Func.Loc.:					
			Drawing No.: BTS 017					
138506	Return Idler	Return Idler 900mm Roll Face	Conveyor Return Idler	BTS 018 (Sheet 1 & 2)	1500	Each		
			Type: Garland V-Return Idler - S- 25-1650BW					
			Idler Diameter: 152mm					
			Shaft Diameter: 25 (Series 25)					

Respondent's Signature

Date & Company Stamp

			Overall Shaft Length: 960mm					
			Belt Width: 1650					
			Func.Loc.:					
			Drawing No.: BTS 018 (Sheet 1 & 2)					
152026	Return Idler	Rubber Return Idler	Conveyor Return Idler		90	Each		
			Type: Rubber Return Idler					
			Idler Diameter: 178mm					
			Shaft Diameter: 30 (Series 30)					
			Overall Shaft Length:					
			Belt Width: 1650					
			Func.Loc.:					
			Drawing No.:					
143363	Return Idler	Return Idler 965mm Roll Face	Conveyor Return Idler		30	Each		
			Type: Rubber Conical Roller					
			Idler Diameter: 582mm					
			Shaft Diameter:					
			Overall Shaft Length:					
			Belt Width:					
			Func.Loc.:					
			Drawing No.:					
138502	Return Idler	Rubber Conical Idler	Conveyor Return Idler	BTS 015	300	Each		
			Type: SR4-V- Return Idler - S30-1800BW-2Roll					
			Idler Diameter: 152mm					
			Shaft Diameter: 30 (Series 30)					
			Overall Shaft Length: 1022mm					

Respondent's Signature

Date & Company Stamp

			Belt Width: 1800					
			Func.Loc.: S/R 4					
			Drawing No.: BTS 015					
115629	Return Idler	Return Idler 1908mm Roll Face	Conveyor Return Idler	BTS 029	45	Each		
			Type: Steel Flat Return Idler					
			Idler Diameter: 152mm					
			Shaft Diameter: 40 (Series 40)					
			Overall Shaft Length: 1955mm					
			Belt Width: 1800					
			Func.Loc.: Boom Conveyor - S/R 1-3					
			Drawing No.: BTS 029					
134971	Return Idler	Return Idler 900mm Roll Face	Conveyor Return Idler	BTS 032	3000	Each		
			Type: Rubber V-Return Idler					
			Idler Diameter: 178mm					
			Shaft Diameter: 25 (Series 25)					
			Overall Shaft Length: 944mm					
			Belt Width: 1650					
			Func.Loc.:					
			Drawing No.: BTS 032					
127584	Return Idler	Return Idler 900mm Roll Face	Conveyor Return Idler	BTS 033	15000	Each		
			Type: Rubber V-Return Idler - Complete	Ref: A3SBH2046				
			Idler Diameter: 178mm	A1S078030				
			Shaft Diameter: 25 (Series 25)	A3SBH2112				

Respondent's Signature

Date & Company Stamp

			Overall Shaft Length: 960mm				
			Belt Width: 1650				
			Func.Loc.:				
			Drawing No.: BTS 033				
			Ref: A3SBH2046, A1S078030 & A3SBH2112				
			Note:				
			Complete Assembled Roller Strings DRG:A3SBH2046				
			Drawing Number A1S078030&SBH2112 (For Links)				
			Return Roller String To Be Assembled Consisting Of				
			Two Return Rollers and Three Galvanised Link Sets				
			with chain on both ends, 5 link chain - 13mm galv.				
			(39x45.5)				
130193	Return Idler	Return Idler 886mm Roll Face	Conveyor Return Idler	A3SBH2135	900	Each	
			Type: Fixed Return Idler - Rubber				
			Idler Diameter: 157mm				
			Shaft Diameter: 25 (Series 25)				
			Overall Shaft Length: 934mm				
			Belt Width: 1650				
			Func.Loc.:				
			Drawing No.: A3SBH2135				

118530	Return Idler	Training Idler 900mm Roll Face	Conveyor Return Idler	A3SBH2031	60	Each		
			Type: Self Trainer Idler - Rubber	Ref: A3SBH2046				
			Idler Diameter: 180mm					
			Shaft Diameter: 25 (Series 25)					
			Overall Shaft Length: 952mm					
			Belt Width: 1650					
			Func.Loc.:					
			Drawing No.: A3SBH2031					
			Ref: A3SBH2046					
143364	Return Idler	Rubber Conical Return Idler	Conveyor Return Idler		15	Each		
			Type: Conical idler - Rubber					
			Idler Diameter: 552mm					
			Shaft Diameter: 30 (Series 30)					
			Overall Shaft Length:					
			Belt Width: 1650					
			Func.Loc.:					
			Drawing No.:					
131070	Return Idler	Return Idler 885mm Roll Face	Conveyor Return Idler	BTS 039	450	Each		
			Type: Rubber Return Idler 885 Idler Face					
			Idler Diameter: 152mm					
			Shaft Diameter: 30 (Series 30)					
			Overall Shaft Length: 933mm					
			Belt Width: 1800					
			Func.Loc.: S/R1-3					

Respondent's Signature

Date & Company Stamp

Drawing No.: BTS 039		
	Total price, exclusive of VAT:	
	VAT @15%	
	Total price, inclusive of VAT.	

Respondent's Signature

Date & Company Stamp

Respondent's Signature

Date & Company Stamp

Respondents are to note that Transnet will round off final pricing scores to the nearest 2 (two) decimal places.

Notes to Pricing:

- a) Respondents are to note that if the price offered by the highest scoring bidder is not market-related, Transnet may not award the contract to that Respondent. Transnet may-
 - (i) negotiate a market-related price with the Respondent scoring the highest points or cancel the RFP;
 - (ii) if that Respondent does not agree to a market-related price, negotiate a market-related price with the Respondent scoring the second highest points or cancel the RFP;
 - (iii) if the Respondent scoring the second highest points does not agree to a market-related price, negotiate a market-related price with the Respondent scoring the third highest points or cancel the RFP.

If a market-related price is not agreed with the Respondent scoring the third highest points, Transnet must cancel the RFP.

- b) Prices must be quoted in South African Rand inclusive of VAT.
- c) Any disbursement not specifically priced for will not be considered/accepted by Transnet.
- d) To facilitate like-for-like comparison bidders must submit pricing strictly in accordance with this pricing schedule and not utilise a different format. Deviation from this pricing schedule could result in a bid being declared non-responsive.
- e) Rates proposed must be aligned with the Guide on Hourly Fee Rates for Consultants” by the Department of Public Service and Administration (DPSA);
- f) Quantities given are estimates only. Any orders resulting from this RFP will be on an “as and when required” basis.
- g) Please note that should you have offered a discounted price(s), Transnet will only consider such price discount(s) in the final evaluation stage if offered on an unconditional basis.
- h) Where a Respondent’s price(s) includes imported goods/items, the rate of exchange to be used must be in South African Rands for purposes of determining whether the price is market related or not and must be the currency’s rate published by the South African Reserve Bank on the date of the advertisement of the bid:

Currency rate of exchange utilised: _____

- i) In respect of incoterms conditions, if applicable, please refer to paragraph 25 of the General Bid Conditions which is attached to the RFQ as Annexure
- j) Manufacturing and delivery lead time calculated from date of receipt of purchase order: _____ weeks.
- k) Respondents, if awarded the contract, are required to indicate that their prices quoted would be kept firm and fixed for the contract duration. [Not to be confused with bid validity period Section 2, clause 1]

YES	
------------	--

- l) Respondents, if awarded the contract, are required to indicate that their prices quoted would be kept firm and fixed a period of 12 months, subject thereafter to adjustment (i.e. after the initial period of 12 months), utilizing the following price index/indices/adjustment formula. [Not to be confused with bid validity period Section 2, clause 1]

1. DISCLOSURE OF CONTRACT INFORMATION

PRICES TENDERED

Respondents are to note that, on award of business, Transnet is required to publish the tendered prices of the successful and unsuccessful Respondents *inter alia* on the National Treasury e-Tender Publication Portal, (www.etenders.gov.za), as required per National Treasury Instruction Note 01 of 2015/2016.

JOHANNESBURG STOCK EXCHANGE DEBT LISTING REQUIREMENTS

Transnet may also be required to disclose information relating to the subsequent contract i.e. the name of the company, Services provided by the company, the value and duration of the contract, etc. in compliance with the Johannesburg Stock Exchange (JSE) Debt Listing Requirements.

DOMESTIC PROMINENT INFLUENTIAL PERSONS (DPIP) OR FOREIGN PROMINENT PUBLIC OFFICIALS (FPPO)

Transnet is free to procure the services of any person within or outside the Republic of South Africa in accordance with applicable legislation. Transnet shall not conduct or conclude business transactions, with any Respondents without having:

- Considered relevant governance protocols;
- Determined the DPIP or FPPO status of that counterparty; and
- Conducted a risk assessment and due diligence to assess the potential risks that may be posed by the business relationship.

As per the Transnet Domestic Prominent Influential Persons (DPIP) and Foreign Prominent Public Officials (FPPO) and Related Individuals Policy available on Transnet website <https://www.transnet.net/search/pages/results.aspx?k=FPIDP#k=DPIP>, Respondents are required to disclose any commercial relationship with a DPIP or FPPO (as defined in the Policy) by completing the following section:

The below form contains personal information as defined in the Protection of Personal Information Act, 2013 (the "Act"). By completing the form, the signatory consents to the processing of her/his personal information in accordance with the requirements of the Act. Consent cannot unreasonably be withheld.						
Is the Respondent (Complete with a "Yes" or "No")						
A DPIP/FPPO		Closely Related to a DPIP/FPPO		Closely Associated to a DPIP/FPPO		
List all known business interests, in which a DPIP/FPPO may have a direct/indirect interest or significant participation or involvement.						
No	Name of Entity / Business	Role in the Entity / Business (Nature of interest/ Participation)	Shareholding %	Registration Number	Status (Mark the applicable option with an X)	
					Active	Non-Active
1						
2						
3						

Respondents declaring a commercial relationship with a DPIP or FPPO are to note that Transnet is required to annually publish on its website a list of all business contracts entered into with DPIP or FPPO. This list will include successful Respondents, if applicable.

2. "AS AND WHEN REQUIRED" CONTRACTS

- 2.1 Purchase orders will be placed on the Service provider(s) from time to time as and when Services are required.
- 2.2 Transnet reserves the right to place purchase orders until the last day of the contract for deliveries to be effected, within the delivery period / lead time specified, beyond the expiry date of the contract under the same terms and conditions as agreed upon.
- 2.3 Delivery requirements may be stipulated in purchase orders and scheduled deliveries may be called for. However, delivery periods and maximum monthly rates of delivery offered by the Respondents will be used as guidelines in establishing lead times and monthly delivery requirements with the Supplier.
- 2.4 Where scheduled deliveries are required, the delivery period(s) specified must be strictly complied with, unless otherwise requested by Transnet. Material supplied earlier than specified may not be paid for or may be returned by Transnet, with the Supplier being held liable for all expenses so incurred, e.g. handling and transport charges.
- 2.5 If the delivery period offered by the Respondents is subject to a maximum monthly production capacity, full particulars must be indicated in Section 4 [*Pricing and Delivery Schedule*]
- 2.6 The Respondent must state hereunder its annual holiday closedown period [if applicable] and whether this period has been included in the delivery lead time offered:

- 2.7 Respondents are required to indicate below the action that the Respondent proposes to take to ensure continuity of supply during non-working days or holidays.

3. RETURN OF SURPLUS GOODS

RESPONDENTS ARE REQUIRED TO INDICATE WHETHER THEY HAVE A RETURN POLICY IN PLACE (IF SO ATTACH A COPY):

YES		NO	
------------	--	-----------	--

Respondents are required to indicate a reasonable timeframe during which Transnet may return any surplus goods:

4. IMPORTED CONTENT

THE RESPONDENTS MUST STATE HEREUNDER THE VALUE AND PERCENTAGE OF THE IMPORTED CONTENT AS WELL AS THE COUNTRY OF ORIGIN IN RESPECT OF EACH ITEM TENDERED FOR:

RFP ITEM NO / DESCRIPTION.	VALUE	% COST	COUNTRY OF ORIGIN

Note: Where more than one country is applicable to one item, the Respondents must furnish this information separately.

5. SERVICE LEVELS

- 5.1 An experienced national account representative(s) is required to work with Transnet’s procurement department. [No sales representatives are needed for individual department or locations]. Additionally, there shall be a minimal number of people, fully informed and accountable for this agreement.
- 5.2 Transnet will have quarterly reviews with the Supplier’s account representative on an on-going basis.
- 5.3 Transnet reserves the right to request that any member of the Supplier’s team involved on the Transnet account be replaced if deemed not to be adding value for Transnet.
- 5.4 The Service provider guarantees that it will achieve a 95% [ninety-five per cent] service level on the following measures:
 - a) Random checks on compliance with quality/quantity/specifications
 - b) On-time delivery

If the Service provider does not achieve this level as an average over each quarter, Transnet will receive a 1.5% [one and a half per cent] rebate on quarterly sales payable in the next quarter

- 5.5 The Service provider must provide a telephone number for customer service calls.
- 5.6 Failure of the Service provider to comply with stated service level requirements will give Transnet the right to cancel the contract in whole, without penalty to Transnet, giving 30 [thirty] calendar days’ notice to the Service provider of its intention to do so.

Acceptance of Service Levels:

YES	
------------	--

NO	
-----------	--

6. RISK

Respondents must elaborate on the control measures put in place by their entity, which would mitigate the risk to Transnet pertaining to potential non-performance by the Respondent, in relation to:

6.1 Quality and specification of Services delivered:

6.2 Continuity of supply:

6.3 Compliance with the Occupational Health and Safety Act, 85 of 1993:

6.4 Compliance with the National Railway Safety Regulator Act, 16 of 2002:

SIGNED at _____ on this ____ day of _____ 20__

SIGNATURE OF WITNESSES

ADDRESS OF WITNESSES

1 _____
Name _____

2 _____
Name _____

SIGNATURE OF RESPONDENT'S AUTHORISED REPRESENTATIVE: _____

NAME: _____

DESIGNATION: _____

SECTION 5: PROPOSAL FORM AND LIST OF RETURNABLE DOCUMENTS

I/We _____
[name of entity, company, close corporation or partnership] of *[full address]*

—
carrying on business trading/operating as

—
represented by _____
in my capacity as

being duly authorised thereto by a Resolution of the Board of Directors or Members or Certificate of Partners, dated _____ to enter into, sign execute and complete any documents relating to this proposal and any subsequent Agreement. The following list of persons are hereby authorised to negotiate on behalf of the abovementioned entity, should Transnet decide to enter into Post Tender Negotiations with highest ranked bidder(s).

FULL NAME(S)

CAPACITY

SIGNATURE

Respondent's Signature

Date & Company Stamp

_____	_____

_____	_____

_____	_____

_____	_____

I/We hereby offer to supply/provide the abovementioned Services at the prices quoted in the schedule of prices in accordance with the terms set forth in the documents listed in the accompanying schedule of RFP documents.

I/We agree to be bound by those conditions in Transnet's:

- (i) Master Agreement (which may be subject to amendment at Transnet's discretion if applicable);
- (ii) General Bid Conditions; and
- (iii) any other standard or special conditions mentioned and/or embodied in this Request for Proposal.

I/We accept that unless Transnet should otherwise decide and so inform me/us in the letter of award, this Proposal [and, if any, its covering letter and any subsequent exchange of correspondence], together with Transnet's acceptance thereof shall constitute a binding contract between Transnet and me/us.

Should Transnet decide that a formal contract should be signed and so inform me/us in a letter of award [the **Letter of Award**], this Proposal [and, if any, its covering letter and any subsequent exchange of correspondence] together with Transnet's Letter of Award, shall constitute a binding contract between Transnet and me/us until the formal contract is signed.

I/We further agree that if, after I/we have been notified of the acceptance of my/our Proposal, I/we fail to enter into a formal contract if called upon to do so, or fail to commence the supply/provision of Services within 2 [two] weeks thereafter, Transnet may, without prejudice to any other legal remedy which it may have, recover from me/us any expense to which it may have been put in calling for Proposals afresh and/or having to accept any less favourable Proposal.

Furthermore, I/we agree to a penalty clause/s which will allow Transnet to invoke a penalty against us for non-compliance with material terms of this RFP including the delayed delivery of the Services due to non-performance by ourselves, , etc.

I/we agree that non-compliance with any of the material terms of this RFP, including those mentioned above, will constitute a material breach of contract and provide Transnet with cause for cancellation.

ADDRESS FOR NOTICES

The law of the Republic of South Africa shall govern any contract created by the acceptance of this RFP. The *domicilium citandi et executandi* shall be a place in the Republic of South Africa to be specified by the Respondent hereunder, at which all legal documents may be served on the Respondent who shall agree to submit to the

Respondent's Signature

Date & Company Stamp

jurisdiction of the courts of the Republic of South Africa. Foreign Respondents shall, therefore, state hereunder the name of their authorised representative in the Republic of South Africa who has the power of attorney to sign any contract which may have to be entered into in the event of their Proposal being accepted and to act on their behalf in all matters relating to such contract.

Respondent to indicate the details of its *domicilium citandi et executandi* hereunder:

Name of Entity:

Facsimile:

Address:

NOTIFICATION OF AWARD OF RFP

As soon as possible after approval to award the contract(s), the successful Respondent [**the Supplier**] will be informed of the acceptance of its Proposal. Transnet will also publish the outcome of the tender, including successful and unsuccessful bidders, in the National Treasury e-tender portal. Any unsuccessful bidder has a right to request reasons for the bid not to be successful and Transnet has a duty to provide those reasons on receipt of the request from the bidder.

VALIDITY PERIOD

Transnet requires a validity period of 180 Business Days [from closing date] against this RFP, excluding the first day and including the last day.

NAME(S) AND ADDRESS / ADDRESSES OF DIRECTOR(S) OR MEMBER(S)

The Respondent must disclose hereunder the full name(s) and address(s) of the director(s) or members of the company or close corporation [**C.C.**] on whose behalf the RFP is submitted.

(i) Registration number of company / C.C. _____

(ii) Registered name of company / C.C. _____

(iii) Full name(s) of director/member(s) Address/Addresses ID Number(s)

RETURNABLE DOCUMENTS

Returnable Documents means all the documents, Sections and Annexures, as listed in the tables below. There are three types of returnable documents as indicated below and Respondents are urged to ensure that these documents are returned with their bids based on the consequences of non-submission as indicated below:

Mandatory Returnable Documents	<i>Failure to provide all these Mandatory Returnable Documents at the Closing Date and time of this RFP <u>will</u> result in a Respondent's disqualification.</i>
--------------------------------	---

Respondent's Signature

Date & Company Stamp

Returnable Documents Used for Scoring	<i>Failure to provide all Returnable Documents used for purposes of scoring a bid, by the closing date and time of this bid will not result in a Respondent's disqualification. However, Bidders will receive an automatic score of zero for the applicable evaluation criterion.</i>
Essential Returnable Documents	<i>Failure to provide essential Returnable Documents <u>will</u> result in Transnet affording Respondents a further opportunity to submit by a set deadline. Should a Respondent thereafter fail to submit the requested documents, this may result in a Respondent's disqualification.</i>

All Returnable Sections, as indicated in the header and footer of the relevant pages, must be signed, stamped and dated by the Respondent.

a) Mandatory Returnable Documents

Respondents are required to submit with their bid submissions the following **Mandatory Returnable Documents**, and also to confirm submission of these documents by so indicating [Yes or No] in the tables below:

MANDATORY RETURNABLE DOCUMENTS	SUBMITTED [Yes/No]
SECTION 4 : Pricing and Delivery Schedule	

b) Returnable Documents Used for Scoring

In addition to the requirements of section (a) above, Respondents are further required to submit with their Proposals the following **Returnable Documents Used for Scoring** and also to confirm submission of these documents by so indicating [Yes or No] in the table below:

RETURNABLE DOCUMENTS USED FOR SCORING	SUBMITTED [Yes or No]
The Service Provider shall have more than five (5) years cumulative experience in supplying of conveyor idlers in the last ten (10) years.	
Valid copy of a SANS 1313-1:2012 or SANS 1313-3:2012 permit submitted indicating the service provider's compliance to a manufacturing standard	
The service provider shall guarantee the workmanship and quality for a period of more than twelve (12) months on the conveyor idlers post the installation.	

c) Essential Returnable Documents:

Over and the above the requirements of section (a) and (b) mentioned above, Respondents are further required to submit with their Proposals the following **Essential Returnable Documents** and also to confirm submission of these documents by so indicating [Yes or No] in the table below:

CONTINUED VALIDITY OF RETURNABLE DOCUMENTS

The successful Respondent will be required to ensure the validity of all returnable documents, including but not limited to its valid proof of B-BBEE status, for the duration of any contract emanating from this RFP. Should the Respondent be awarded the contract [**the Agreement**] and fail to present Transnet with such renewals as and

Respondent's Signature

Date & Company Stamp

when they become due, Transnet shall be entitled, in addition to any other rights and remedies that it may have

	SUBMITTED [Yes or No]
In the case of Joint Ventures, a copy of the Joint Venture Agreement or written confirmation of the intention to enter into a Joint Venture Agreement	
Latest Financial Statements signed by your Accounting Officer or latest Audited Financial Statements plus 2 previous years	
Section 1: SBD1 Form	
SECTION 5 : Proposal Form and List of Returnable documents	
SECTION 6 : Certificate Of Acquaintance with RFP, Terms & Conditions & Applicable Documents	
SECTION 7 : RFP Declaration and Breach of Law Form	
SECTION 8 :RFP Clarification	
SECTION 9: Specific Goals Points Claim Form	
SECTION 10: Certificate of non-compulsory Site Meeting / RFP Briefing	
SECTION 11: Protection of Personal Information	
Valid Tax Clearance Certificate	
Sworn affidavit and SANAS approved certificate	

in terms of the eventual Agreement, to terminate such Agreement immediately without any liability and without prejudice to any claims which Transnet may have for damages against the Respondent.

SIGNED at _____ on this ____ day of _____ 20__

SIGNATURE OF WITNESSES

ADDRESS OF WITNESSES

1 _____

Name _____

2 _____

Name _____

SIGNATURE OF RESPONDENT'S AUTHORISED REPRESENTATIVE: _____

NAME: _____

DESIGNATION: _____

Respondent's Signature

Date & Company Stamp

**SECTION 6: CERTIFICATE OF ACQUAINTANCE WITH RFP, MASTER AGREEMENT &
APPLICABLE DOCUMENTS**

By signing this certificate the Respondent is deemed to acknowledge that he/she has made himself/herself thoroughly familiar with, and agrees with all the conditions governing this RFP. This includes those terms and conditions contained in any printed form stated to form part hereof, including but not limited to the documents stated below. As such, Transnet SOC Ltd will recognise no claim for relief based on an allegation that the Respondent overlooked any such term or condition or failed properly to take it into account for the purpose of calculating tendered prices or any other purpose:

1	Transnet's General Bid Conditions
2	Master Agreement and SLA attached
3	Transnet's Supplier Integrity Pact
4	Non-disclosure Agreement
5	Specifications and drawings attached to this RFP

Note: Should a Respondent be successful and awarded the bid, they will be required to complete a Supplier Declaration Form for registration as a vendor onto the Transnet vendor master database.

Should the Bidder find any terms or conditions stipulated in any of the relevant documents quoted in the RFP unacceptable, it should indicate which conditions are unacceptable and offer alternatives by written submission on its company letterhead, attached to its submitted Bid. Any such submission shall be subject to review by Transnet's Legal Counsel who shall determine whether the proposed alternative(s) are acceptable or otherwise, as the case may be. A material deviation from any term or condition may result in disqualification.

Bidders accept that an obligation rests on them to clarify any uncertainties regarding any bid to which they intend to respond on, before submitting the bid. **The Bidder agrees that he/she will have no claim or cause of action based on an allegation that any aspect of this RFP was unclear but in respect of which he/she failed to obtain clarity.**

The bidder understands that his/her Bid will be disqualified if the Certificate of Acquaintance with RFP documents included in the RFP as a returnable document, is found not to be true and complete in every respect.

SIGNED at _____ on this ____ day of _____ 20__

SIGNATURE OF WITNESSES

ADDRESS OF WITNESSES

1 _____
Name _____

2 _____
Name _____

SIGNATURE OF RESPONDENT'S AUTHORISED REPRESENTATIVE: _____

NAME: _____

DESIGNATION: _____

Respondent's Signature

Date & Company Stamp

SECTION 7: RFP DECLARATION AND BREACH OF LAW FORM

NAME OF ENTITY: _____

We _____ do hereby certify that:

1. Transnet has supplied and we have received appropriate responses to any/all questions [as applicable] which were submitted by ourselves for RFP Clarification purposes;
2. We have received all information we deemed necessary for the completion of this Request for Proposal [RFP];
3. We have been provided with sufficient access to the existing Transnet facilities/sites and any and all relevant information relevant to the Services as well as Transnet information and Employees, and have had sufficient time in which to conduct and perform a thorough due diligence of Transnet's operations and business requirements and assets used by Transnet. Transnet will therefore not consider or permit any pre- or post-contract verification or any related adjustment to pricing, service levels or any other provisions/conditions based on any incorrect assumptions made by the Respondent in arriving at his Bid Price.
4. At no stage have we received additional information relating to the subject matter of this RFP from Transnet sources, other than information formally received from the designated Transnet contact(s) as nominated in the RFP documents;
5. We are satisfied, insofar as our entity is concerned, that the processes and procedures adopted by Transnet in issuing this RFP and the requirements requested from Bidders in responding to this RFP have been conducted in a fair and transparent manner;
6. We have complied with all obligations of the Bidder/Supplier as indicated in the Transnet Supplier Integrity which includes but are not limited to ensuring that we take all measures necessary to prevent corrupt practices, unfairness and illegal activities in order to secure or in furtherance to secure a contract with Transnet;
7. We declare that a family, business and/or social relationship **exists / does not exist** [delete as applicable] between an owner / member / director / partner / shareholder of our entity and an employee or board member of the Transnet Group including any person who may be involved in the evaluation and/or adjudication of this Bid;
8. We declare that an owner / member / director / partner / shareholder of our entity **is / is not** [delete as applicable] an employee or board member of Transnet;
9. In addition, we declare that an owner / member / director / partner / shareholder/employee of our entity **has / has not been** [delete as applicable] a former employee or board member of Transnet in the past 10 years. I further declare that if they were a former employee or board member of Transnet in the past 10 years that they **were/were not** involved in the bid preparation or had access to the information related to this RFP; and

Respondent's Signature

Date & Company Stamp

10. If such a relationship as indicated in paragraph 7, 8 and/or 9 exists, the Respondent is to complete the following section:

FULL NAME OF OWNER/MEMBER/DIRECTOR/
PARTNER/SHAREHOLDER/EMPLOYEE: ADDRESS:

Indicate nature of relationship with Transnet:

[Failure to furnish complete and accurate information in this regard will lead to the disqualification of a response and may preclude a Respondent from doing future business with Transnet. Information provided in the declarations may be used by Transnet and/or its affiliates to verify the correctness of the information provided]

11. We declare, to the extent that we are aware or become aware of any relationship between ourselves and Transnet [other than any existing and appropriate business relationship with Transnet] which could unfairly advantage our entity in the forthcoming adjudication process, we shall notify Transnet immediately in writing of such circumstances.

BIDDER'S DISCLOSURE (SBD4)

12 PURPOSE OF THE FORM

12.1 Any person (natural or juristic) may make an offer or offers in terms of this invitation to bid. In line with the principles of transparency, accountability, impartiality, and ethics as enshrined in the Constitution of the Republic of South Africa and further expressed in various pieces of legislation, it is required for the bidder to make this declaration in respect of the details required hereunder.

12.2 Where a person/s are listed in the Register for Tender Defaulters and / or the List of Restricted Suppliers, that person will automatically be disqualified from the bid process.

13 Bidder's declaration

13.1 Is the bidder, or any of its directors / trustees / shareholders / members / partners or any person having a controlling interest¹ in the enterprise, employed by the state? **YES/NO**

13.1.1. If so, furnish particulars of the names, individual identity numbers, and, if applicable, state employee numbers of sole proprietor/ directors / trustees / shareholders / members/ partners or any person having a controlling interest in the enterprise, in table below.

Full Name	Identity Number	Name of State institution

¹ the power, by one person or a group of persons holding the majority of the equity of an enterprise, alternatively, the person/s having the deciding vote or power to influence or to direct the course and decisions of the enterprise.

13.2 Do you, or any person connected with the bidder, have a relationship with any person who is employed by the procuring institution?

YES/NO

13.2.1. If so, furnish particulars:

.....
.....

13.3 Does the bidder or any of its directors / trustees / shareholders / members / partners or any person having a controlling interest in the enterprise have any interest in any other related enterprise whether or not they are bidding for this contract?

YES/NO

13.3.1. If so, furnish particulars:

.....
.....

14 DECLARATION

I, the undersigned, (name)..... in submitting the accompanying bid, do hereby make the following statements that I certify to be true and complete in every respect:

14.1 I have read and I understand the contents of this disclosure;

14.2 I understand that the accompanying bid will be disqualified if this disclosure is found not to be true and complete in every respect;

14.3 The bidder has arrived at the accompanying bid independently from, and without consultation, communication, agreement or arrangement with any competitor. However, communication between partners in a joint venture or consortium² will not be construed as collusive bidding.

² Joint venture or Consortium means an association of persons for the purpose of combining their expertise, property, capital, efforts, skill and knowledge in an activity for the execution of a contract.

- 14.4 In addition, there have been no consultations, communications, agreements or arrangements with any competitor regarding the quality, quantity, specifications, prices, including methods, factors or formulas used to calculate prices, market allocation, the intention or decision to submit or not to submit the bid, bidding with the intention not to win the bid and conditions or delivery particulars of the products or services to which this bid invitation relates.
- 14.5 The terms of the accompanying bid have not been, and will not be, disclosed by the bidder, directly or indirectly, to any competitor, prior to the date and time of the official bid opening or of the awarding of the contract.
- 14.6 There have been no consultations, communications, agreements or arrangements made by the bidder with any official of the procuring institution in relation to this procurement process prior to and during the bidding process except to provide clarification on the bid submitted where so required by the institution; and the bidder was not involved in the drafting of the specifications or terms of reference for this bid.
- 14.7 I am aware that, in addition and without prejudice to any other remedy provided to combat any restrictive practices related to bids and contracts, bids that are suspicious will be reported to the Competition Commission for investigation and possible imposition of administrative penalties in terms of section 59 of the Competition Act No 89 of 1998 and or may be reported to the National Prosecuting Authority (NPA) for criminal investigation and or may be restricted from conducting business with the public sector for a period not exceeding ten (10) years in terms of the Prevention and Combating of Corrupt Activities Act No 12 of 2004 or any other applicable legislation.

I CERTIFY THAT THE INFORMATION FURNISHED IN PARAGRAPHS 12, 13 and 14 ABOVE IS CORRECT.

I ACCEPT THAT THE STATE MAY REJECT THE BID OR ACT AGAINST ME IN TERMS OF PARAGRAPH 6 OF PFMA SCM INSTRUCTION 03 OF 2021/22 ON PREVENTING AND COMBATING ABUSE IN THE SUPPLY CHAIN MANAGEMENT SYSTEM SHOULD THIS DECLARATION PROVE TO BE FALSE.

BREACH OF LAW

We further hereby certify that *I/we* (the bidding entity and/or any of its directors, members or partners) **have/have not been** [delete as applicable] found guilty during the preceding 5 [five] years of a serious breach of law, including but not limited to a breach of the Competition Act, 89 of 1998, by a court of law, tribunal or other administrative body. The type of breach that the Respondent is required to disclose excludes relatively minor offences or misdemeanours, e.g. traffic offences. This includes the imposition of an administrative fine or penalty.

Where found guilty of such a serious breach, please disclose:

NATURE OF BREACH:

DATE OF BREACH: _____

Furthermore, I/we acknowledge that Transnet SOC Ltd reserves the right to exclude any Respondent from the bidding process, should that person or entity have been found guilty of a serious breach of law, tribunal or regulatory obligation.

SIGNED at _____ on this ____ day of _____ 20__

For and on behalf of _____ duly authorised hereto	AS WITNESS:
Name:	Name:
Position:	Position:
Signature:	Signature:
Date:	Registration No of Company/CC
Place:	Registration Name of Company/CC

Respondent's Signature

Date & Company Stamp

SECTION 9 : SPECIFIC GOALS POINTS CLAIM FORM

This preference form must form part of all bids invited. It contains general information and serves as a claim for preference points for specific goals Contribution. Transnet will award preference points to companies who provide valid proof of evidence of as per the table below.

NB: BEFORE COMPLETING THIS FORM, BIDDERS MUST STUDY THE GENERAL CONDITIONS, DEFINITIONS AND DIRECTIVES APPLICABLE IN RESPECT OF SPECIFIC GOALS, AS PRESCRIBED IN THE PREFERENTIAL PROCUREMENT POLICY FRAMEWORK ACT, 2000.

1. GENERAL CONDITIONS

- 1.1 The following preference point systems are applicable to all bids:
- the 80/20 system for requirements with a Rand value of up to R50 000 000 (all applicable taxes included); and
 - the 90/10 system for requirements with a Rand value above R50 000 000 (all applicable taxes included).
- 1.2 The value of this bid is estimated to exceed R50 000 000 (all applicable taxes included) and therefore the 90/10 preference point system shall be applicable. Despite the stipulated preference point system, Transnet shall use the lowest acceptable bid to determine the applicable preference point system in a situation where all received acceptable bids are received outside the stated preference point system.
- 1.3 Preference points for this bid shall be awarded for:
- (a) Price;
 - (b) B-BBEE Status Level of Contribution; and
 - (c) Any other specific goal determined in Transnet preferential procurement policy.
- 1.4 The maximum points for this bid are allocated as follows:

	POINTS
PRICE	90
BBEE STATUS LEVEL OF CONTRIBUTION <ul style="list-style-type: none"> • B-BBEE Level 1 & 2 =5 • Local content and production =5 	10
Total points for Price and Specific Goals must not exceed	100

- 1.5 Failure on the part of a bidder to submit proof of evidence for any of the specific goals together with the bid will be interpreted to mean that preference points are not claimed.
- 1.6 The purchaser reserves the right to require of a bidder, either before a bid is adjudicated or at any time subsequently, to substantiate any claim in regard to preferences, in any manner required by the purchaser.

2. DEFINITIONS

- (a) **"all applicable taxes"** includes value-added tax, pay as you earn, income tax, unemployment insurance fund contributions and skills development levies;
- (b) **"B-BBEE"** means broad-based black economic empowerment as defined in section 1 of the Broad-

Respondent's Signature

Date & Company Stamp

Based Black Economic Empowerment Act;

- (c) **"B-BBEE status level of contributor"** means the B-BBEE status received by a measured entity based on its overall performance using the relevant scorecard contained in the Codes of Good Practice on Black Economic Empowerment, issued in terms of section 9(1) of the Broad-Based Black Economic Empowerment Act;
- (d) **"Ownership"** means 51% black ownership
- (e) **"bid"** means a written offer in a prescribed or stipulated form in response to an invitation by an organ of state for the supply/provision of services, works or goods, through price quotations, advertised competitive bidding processes or proposals;
- (f) **"Broad-Based Black Economic Empowerment Act"** means the Broad-Based Black Economic Empowerment Act, 2003 (Act No. 53 of 2003);
- (g) **"EME"** means an Exempted Micro Enterprise as defines by Codes of Good Practice under section 9 (1) of the Broad-Based Black Economic Empowerment Act, 2003 (Act No. 53 of 2003);
- (h) **"functionality"** means the ability of a bidder to provide goods or services in accordance with specification as set out in the bid documents
- (i) **"Price"** includes all applicable taxes less all unconditional discounts.
- (j) **"Proof of B-BBEE Status Level of Contributor"**
 - i) the B-BBEE status level certificate issued by an authorised body or person;
 - ii) a sworn affidavit as prescribed by the B-BBEE Codes of Good Practice; or
 - iii) any other requirement prescribed in terms of the B-BBEE Act.
- (k) **"QSE"** means a Qualifying Small Enterprise as defines by Codes of Good Practice under section 9 (1) of the Broad-Based Black Economic Empowerment Act, 2003 (Act No. 53 of 2003);
- (l) **"rand value"** means the total estimated value of a contract in South African currency, calculated at the time of bid invitations, and includes all applicable taxes and excise duties.
- (m) **"Specific goals"** means targeted advancement areas or categories of persons or groups either previously disadvantaged or falling within the scope of the Reconstruction and Development Programme identified by Transnet to be given preference in allocation of procurement contracts in line with section 2(1) of the PPPFA.

3. POINTS AWARDED FOR PRICE

3.1 THE 90/10 PREFERENCE POINT SYSTEMS

A maximum of 90 points is allocated for price on the following basis:

90/10

$$P_s = 90 \left(1 - \frac{P_t - P_{\min}}{P_{\min}} \right)$$

Where

P_s = Points scored for comparative price of bid under consideration

P_t = Comparative price of bid under consideration

P_{\min} = Comparative price of lowest acceptable bid

$$P_s = 90 \left(1 + \frac{P_t - P_{\max}}{P_{\max}} \right)$$

Where:

P_s = Points scored for the price of Bid under consideration

Pt = Price of Bid under consideration

Pmax = Price of highest acceptable Bid

In terms of Transnet Preferential Procurement Policy (TPPP) and Procurement Manuals, the following preference points must be awarded to a bidder who provides the relevant required evidence for claiming points

Selected Specific Goal	Number of points allocated (90/10)
B-BBEE Level of contributor (1 or 2)	5
Local content and production	5
Non-Compliant and/or B-BBEE Level 3-8 contributors	0

4. EVIDENCE REQUIRED FOR CLAIMING SPECIFIC GOALS

4.1 In terms of Transnet Preferential Procurement Policy (TPPP) and Procurement Manuals, preference points must be awarded to a bidder for providing evidence in accordance with the table below:

Specific Goals	Acceptable Evidence
B-BBEE	B-BBEE Certificate / Sworn- Affidavit / B-BBEE CIPC Certificate (in case of JV, a consolidated scorecard will be accepted) as per DTIC guideline
30% Black Women Owned Entities	B-BBEE Certificate / Sworn- Affidavit / B-BBEE CIPC Certificate (in case of JV, a consolidated scorecard will be accepted) as per DTIC guideline
+50% Black Youth Owned Entities	Certified copy of ID Documents of the Owners and B-BBEE Certificate / Sworn- Affidavit / B-BBEE CIPC Certificate (in case of JV, a consolidated scorecard will be accepted) as per DTIC guideline
Entities Owned by People with Disability (PWD)	Certified copy of ID Documents of the Owners / Doctor's note and /or EEA1 form confirming the disability
Entities/Black People living in rural areas	Entity 's Municipal/ESKOM bill or letter from Induna/chief confirming residential address not older than 3 months.
South African Enterprises	CIPC Certificate
EME or QSE 51% Black Owned	B-BBEE Certificate / Sworn-Affidavit / CIPC Certificate
Entities that are 51 % Black Owned	CI B-BBEE Certificate / Sworn- Affidavit / B-BBEE CIPC Certificate (in case of JV, a consolidated scorecard will be accepted) as per DTIC guideline
Promoting exports Orientated for Job creation	Section.....Job Creation Schedule Returnable documents
Local Content and Local Production	Returnable Local Content and production Annexures
NIPP	NIPP Returnable documents
Creation of new jobs and labour intensification	Section.....Job Creation Schedule Returnable documents
The promotion of supplier development through sub-contracting or JV for a minimum of 30% of the value of a contract to	Sub-contracting agreements and Declaration / Joint Venture Agreement and CIPC – B-BBEE Certificate / Sworn- Affidavit / B-BBEE CIPC Certificate as per DTIC guideline

<p>South African Companies which are:</p> <ul style="list-style-type: none"> I. 30% Black Women owned, 51% Black Youth and 51% Black people with disabilities II. Entities with a specified minimum B-BBEE level (1 and 2) III. EMEs and/or QSEs who are 51% black-owned 	
<p>The promotion of enterprises located in a specific province/region/municipal area for work to be done or services to be rendered in that province/region/municipal area</p>	<p>CIPC – B-BBEE Certificate / Sworn- Affidavit / B-BBEE CIPC Certificate (in case of JV, a consolidated scorecard will be accepted) as per DTIC guidelines and Proof Registered address of entity</p>

4.2 The table below indicates the required proof of B-BBEE status depending on the category of enterprises:

Enterprise	B-BBEE Certificate & Sworn Affidavit
Large	Certificate issued by SANAS accredited verification agency
QSE	<p>Certificate issued by SANAS accredited verification agency</p> <p>Sworn Affidavit signed by the authorised QSE representative and attested by a Commissioner of Oaths confirming annual turnover and black ownership (only black-owned QSEs - 51% to 100% Black owned)</p> <p>[Sworn affidavits must substantially comply with the format that can be obtained on the DTI's website at www.dti.gov.za/economic_empowerment/bee_codes.jsp.]</p>
EME³	<p>Sworn Affidavit signed by the authorised EME representative and attested by a Commissioner of Oaths confirming annual turnover and black ownership</p> <p>Certificate issued by CIPC (formerly CIPRO) confirming annual turnover and black ownership</p> <p>Certificate issued by SANAS accredited verification agency only if the EME is being measured on the QSE scorecard</p>

4.3 A trust, consortium or joint venture (including unincorporated consortia and joint ventures) must submit a consolidated B-BBEE Status Level verification certificate for every separate bid.

4.4 Tertiary Institutions and Public Entities will be required to submit their B-BBEE status level certificates in terms of the specialized scorecard contained in the B-BBEE Codes of Good Practice.

4.5 A person will not be awarded points for B-BBEE status level if it is indicated in the bid documents that such a bidder intends sub-contracting more than 25% of the value of the contract to any other enterprise that does not qualify for at least the points that such a bidder qualifies for, unless the intended sub-contractor is an EME that has the capability and ability to execute the sub-contract.

4.6 A person awarded a contract may not sub-contract more than 25% of the value of the contract to any other enterprise that does not have an equal or higher B-BBEE status level than the person

concerned, unless the contract is sub-contracted to an EME that has the capability and ability to execute the sub-contract.

- 4.7 Bidders are to note that the rules pertaining to B-BBEE verification and other B-BBEE requirements may be changed from time to time by Transnet or regulatory bodies such as National Treasury or the DTI. It is the Bidder's responsibility to ensure that his/her bid complies fully with all B-BBEE requirements at the time of the submission of the bid.

5. BID DECLARATION

- 5.1 Bidders who claim points in respect of B-BBEE Status Level of Contribution must complete the following:

6. B-BBEE STATUS LEVEL OF CONTRIBUTION CLAIMED IN TERMS OF PARAGRAPHS 1.4 AND 6.1

- 6.1 B-BBEE Status Level of Contribution: . =(maximum of 10 points)
(Points claimed in respect of paragraph 6.1 must be in accordance with the table reflected in paragraph 4.1 and must be substantiated by relevant proof of B-BBEE status level of contributor.)

7. SUB-CONTRACTING

- 7.1 Will any portion of the contract be sub-contracted?

(Tick applicable box)

YES		NO	
-----	--	----	--

- 7.1.1 If yes, indicate:

- i) What percentage of the contract will be subcontracted.....%
- ii) The name of the sub-contractor.....
- iii) The B-BBEE status level of the sub-contractor.....
- iv) Whether the sub-contractor is an EME or QSE.

(Tick applicable box)

YES		NO	
-----	--	----	--

- v) Specify, by ticking the appropriate box, if subcontracting with any of the following enterprises:

Designated Group: An EME or QSE which is at last 51% owned by:	EME ✓	QSE ✓
Black people		
Black people who are youth		
Black people who are women		
Black people with disabilities		
Black people living in rural or underdeveloped areas or townships		
Cooperative owned by black people		
Black people who are military veterans		
OR		
Any EME		
Any QSE		

8. DECLARATION WITH REGARD TO COMPANY/FIRM

- 8.1 Name of company/firm:.....
- 8.2 VAT registration number:.....
- 8.3 Company registration number:.....
- 8.4 TYPE OF COMPANY/ FIRM

- Partnership/Joint Venture / Consortium

- One person business/sole propriety
 - Close corporation
 - Company
 - (Pty) Limited
- [TICK APPLICABLE BOX]

8.5 DESCRIBE PRINCIPAL BUSINESS ACTIVITIES

.....
.....

8.6 COMPANY CLASSIFICATION

- Manufacturer
 - Supplier
 - Professional Supplier
 - Other Suppliers, e.g. transporter, etc.
- [TICK APPLICABLE BOX]

8.7 Total number of years the company/firm has been in business:.....

8.8 I/we, the undersigned, who is / are duly authorised to do so on behalf of the company/firm, certify that the points claimed, based on the B-BBE status level of contribution indicated in paragraphs 1.4 and 6.1 of the foregoing certificate, qualifies the company/ firm for the preference(s) shown and I / we acknowledge that:

- i) The information furnished is true and correct;
- ii) The preference points claimed are in accordance with the General Conditions as indicated in paragraph 1 of this form;
- iii) In the event of a contract being awarded as a result of points claimed as shown in paragraph 1.4 and 6.1, the contractor may be required to furnish documentary proof to the satisfaction of the purchaser that the claims are correct;
- iv) If a bidder submitted false information regarding its B-BBEE status level of contributor or any other matter required in terms of the Preferential Procurement Regulations, 2022 which will affect or has affected the evaluation of a bid the purchaser may, in addition to any other remedy it may have
 - (a) disqualify the person from the bidding process;
 - (b) recover costs, losses or damages it has incurred or suffered as a result of that person's conduct;
 - (c) cancel the contract and claim any damages which it has suffered as a result of having to make less favourable arrangements due to such cancellation;
 - (d) if the successful bidder subcontracted a portion of the bid to another person without disclosing it, Transnet reserves the right to penalise the bidder up to 10 percent of the value of the contract;
 - (e) recommend that the bidder or contractor, its shareholders and directors, or only the shareholders and directors who acted on a fraudulent basis, be restricted by the National Treasury from obtaining business from any organ of state for a period not exceeding 10 years, after the audi alteram partem (hear the other side) rule has been applied; and
 - (f) forward the matter for criminal prosecution.

WITNESSES
1.
2.

Respondent's Signature

..... SIGNATURE(S) OF BIDDERS(S)
DATE:
ADDRESS.....

Date & Company Stamp

Respondent's Signature

Date & Company Stamp

SECTION 10: CERTIFICATE OF ATTENDANCE OF NON-COMPULSORY RFP BRIEFING

It is hereby certified that –

1. _____

2. _____

Representative(s) of _____ *[name of entity]*
attended the site meeting / RFP briefing in respect of the proposed Services to be rendered in terms of
this RFP on _____ 20__

TRANSNET'S REPRESENTATIVE

RESPONDENT'S REPRESENTATIVE

DATE _____

DATE _____

EMAIL _____

NOTE:

This certificate of attendance must be filled in duplicate, one copy to be kept by Transnet and the other copy to be kept by the bidder.

SECTION 11: PROTECTION OF PERSONAL INFORMATION

1. The following terms shall bear the same meaning as contemplated in Section 1 of the Protection of Person information act, No.4 of 2013.(“POPIA”):

consent; data subject; electronic communication; information officer; operator; person; personal information; processing; record; Regulator; responsible party; special information; as well as any terms derived from these terms.
2. Transnet will process all information by the Respondent in terms of the requirements contemplated in Section 4(1) of the POPIA:

Accountability; Processing limitation; Purpose specification; Further processing limitation; Information quality; Openness; Security safeguards and Data subject participation.
3. The Parties acknowledge and agree that, in relation to personal information that will be processed pursuant to this RFP, the Responsible party is “Transnet” and the Data subject is the “Respondent”. Transnet will process personal information only with the knowledge and authorisation of the Respondent and will treat personal information which comes to its knowledge as confidential and will not disclose it, unless so required by law or subject to the exceptions contained in the POPIA.
4. Transnet reserves all the rights afforded to it by the POPIA in the processing of any of its information as contained in this RFP and the Respondent is required to comply with all prescripts as detailed in the POPIA relating to all information concerning Transnet.
5. In responding to this bid, Transnet acknowledges that it will obtain and have access to personal information of the Respondent. Transnet agrees that it shall only process the information disclosed by Respondent in their response to this bid for the purpose of evaluating and subsequent award of business and in accordance with any applicable law.
6. Transnet further agrees that in submitting any information or documentation requested in this RFP, the Respondent is consenting to the further processing of their personal information for the purpose of, but not limited to, risk assessment, assurances, contract award, contract management, auditing, legal opinions/litigations, investigations (if applicable), document storage for the legislatively required period, destruction, de-identification and publishing of personal information by Transnet and/or its authorised appointed third parties.
7. Furthermore, Transnet will not otherwise modify, amend or alter any personal data submitted by the Respondent or disclose or permit the disclosure of any personal data to any third party without the prior written consent from the Respondent. Similarly, Transnet requires the Respondent to process any personal information disclosed by Transnet in the bidding process in the same manner.
8. Transnet shall, at all times, ensure compliance with any applicable laws put in place and maintain sufficient measures, policies and systems to manage and secure against all forms of risks to any information that may be shared or accessed pursuant to this RFP (physically, through a computer or any other form of electronic communication).
9. Transnet shall notify the Respondent in writing of any unauthorised access to information, cybercrimes or suspected cybercrimes, in its knowledge and report such crimes or suspected crimes to the relevant authorities in accordance with applicable laws, after becoming aware of such crimes or suspected crime.

Respondent's Signature

Date & Company Stamp

The Respondent must take all necessary remedial steps to mitigate the extent of the loss or compromise of personal information and to restore the integrity of the affected personal information as quickly as is possible.

10. The Respondent may, in writing, request Transnet to confirm and/or make available any personal information in its possession in relation to the Respondent and if such personal information has been accessed by third parties and the identity thereof in terms of the POPIA. The Respondent may further request that Transnet correct (excluding critical/mandatory or evaluation information), delete, destroy, withdraw consent or object to the processing of any personal information relating to the Respondent in Transnet's possession in terms of the provision of the POPIA and utilizing Form 2 of the POPIA Regulations.
11. In submitting any information or documentation requested in this RFP, the Respondent is hereby consenting to the processing of their personal information for the purpose of this RFP and further confirming that they are aware of their rights in terms of Section 5 of POPIA

Respondents are required to provide consent below:

YES		NO	
------------	--	-----------	--

12. Further, the Respondent declares that they have obtained all consents pertaining to other data subject's personal information included in its submission and thereby indemnifying Transnet against any civil or criminal action, administrative fines or other penalty or loss that may arise as a result of the processing of any personal information that the Respondent submitted.
13. The Respondent declares that the personal information submitted for the purpose of this RFP is complete, accurate, not misleading, is up to date and may be updated where applicable.

Signature of Respondent's authorised representative: _____

Should a Respondent have any complaints or objections to processing of its personal information, by Transnet, the Respondent can submit a complaint to the Information Regulator on <https://www.justice.gov.za/infoereg/>, click on contact us, click on complaints.IR@justice.gov.za



**PROVISION OF SERVICE TO SUPPLY AND DELIVER
CONVEYOR CARRYING IDLERS AND RETURN-IDLER
ASSEMBLIES AS A ONCE OFF PURCHASE AT SALDANHA
IRON ORE TERMINAL**

Document Reference Number:

PSSDCCIRI-30012024

Site:

Bulk Terminal Saldanha

Date: 30 January 2024

*Distribution of this document is restricted to Transnet and
Transnet approved entities only*

TABLE OF CONTENT

1.DEFINITIONS 3

2.ABBREVIATIONS 5

3.BACKGROUND 6

4.SCOPE OF REQUIREMENTS..... 6

5.QUALITY AND SERVICE 9

6.GENERAL SAFETY AND COMPLIANCE SPECIFICATIONS..... 10

1. DEFINITIONS

Commissioning:

The process of assuring that all systems and components of a building or industrial plant or product designed, installed, tested, operated, and maintained according to the operational requirements of the owner or final client.

Contract

A legal binding agreement with specific terms between two or more parties or entities based on mutual consent, which has legal effects and involves transfer of consideration – usually financial or some other type of benefit.

Contract Manager

Transnet employee who is authorised to represent Transnet in terms of the contract and appointed to supervise and/or liaise with the contractor to ensure that the specifications of the contract met (with special emphasis on technical specifications, inspection of quality, on health and safety, environment and quantity of work). A contract manager has the role of executing the plan to achieve the deliverables. This person receives all his authorisations from the project initiator and the stakeholders.

Contract Owner

The person who requires a specific product, goods or services and who is responsible to provide the budget and approval.

Contractor

An employer (organisation) or a person performing any work and has entered into a legal binding business agreement contract to supply a product or provide services to Transnet. This applies to the Suppliers, Vendors, and Consultants, Service providers and Contractors.

Contractor Execution Plan

A site, activity or project specific documented plan in accordance with the client's project requirements. The Contractor to Transnet submits a plan for approval prior to mobilization on site. The Contractor Execution Plan includes, inter alia: Health and Safety, Environmental, Energy, Quality, Delivery plans etc.

Contractor Compliance File a file or other record containing the information in writing required by Transnet.

NB: A file must be submitted for each discipline where applicable e.g. health and safety, environment file etc.

Job Owner:

Any permanent employee of BTS who been trained, tested and found competent, and appointed in writing for the purpose of carrying out or supervising work on plant, machinery and equipment.

Risk Assessment

A risk assessment in this procedure means the process where all risks associated with the contract and its execution identified, mitigated and managed.

Specification

A detailed prescription of the Integrated Management System (IMS) requirements to which equipment, construction, product or service has to comply with this includes various models, drawings and documents. It noted that the specification might even comprise of a multitude of different elements.

Lockout:

The fitting of a padlock (or calliper and padlocks) to an isolator switch so that it cannot be returned to an operating condition.

Permit Acceptor:

Any person who has been appointed in writing to receive a Permit to Work for the purposes of carrying out or supervising work on equipment.

Permit Issuer:

The operations shift manager will be responsible for the issuing of permits.

Permit Number:

A number issued by CCR that logs the work performed, the person responsible for the work and the approximate duration. Note: This is not the same as the sequential number on the Permit to Work.

Permit to Work:

A written document indicating the equipment to work on, the potential hazards, how and where these hazards negated, signatures indicating that equipment is safe and the names of all persons working on the equipment.

Responsible Supervisor:

The Operations and Maintenance Supervisor who been assigned responsibility for the operation and maintenance of a particular section/s of the plant.

2.ABBREVIATIONS

IMS:	Integrated Management System
ISO:	International Organization for Standardization
OHSAS:	Occupational Health and Safety Assessment Series
POM:	Policy Manual
PROC:	Procedure
SOP:	Safe Operating Procedure
QMS:	Quality Management System
SANS:	South African National Standard
SMS:	Safety Management System / Service Management System
TCC:	Transnet Corporate Centre which is the Transnet Head Office
SLD:	Saldanha
TPT:	Transnet Port Terminals
WI:	Work Instructions

3. BACKGROUND

TPT require the services of a service provider with the knowledge and capabilities to supply and deliver conveyor idlers and idler assemblies to the Iron Ore Terminal (hereafter IOT) as a once-off purchase. This requirement must be read in conjunction with the necessary SANS specifications.

Applicable standards:

- 3.1 SANS 286-2 – ISO Limits & Fits
- 3.2 SANS 1313 Part 1 & 3 – Conveyor belt idlers
- 3.3 SANS 657 – 3 – Steel tube for conveyor idlers

Users of these specifications must ensure that they are in possession of the latest versions of these specifications.

4. SCOPE OF REQUIREMENTS

4.1 The conveyor idlers and idler assemblies to be supplied according to the following latest TPT specifications:

- a. Corrosion protection specification (EEAM-Q-008)
- b. Specification for conveyor carrying idlers, scale idlers and idler assemblies for Bulk Terminal Saldanha (SBH 39.07.04 Version 11)
- c. Specification for conveyor return-idlers and return idler assemblies for Bulk Terminal Saldanha (SBH 39.07.12 Version 9)

4.2 List of Carrying and Return Idlers to be supplied to TPT on this once-off purchase:

See Annexure A for the list of Carrying and Return Idlers

4.3 The following minimum requirements must be met:

- 4.3.1 Compliance with the specifications
- 4.3.2 Quality workmanship
- 4.3.3 Inspections by Transnet Port Terminal personnel during manufacturing as well as after delivery
- 4.3.4 Only rollers that was tested and approved will be considered (As set out in Engineering testing procedure)

4.4 The carrying idlers return strings are of link suspended type (Garland) and fixed frame type.

- 4.5 Idlers shall comply with SANS 1313 part 1 & 3. All dimensions shall be as indicated on the drawings represented in Appendix B.
- 4.6 Carrying idler assembly, conveyor; type: underslung roller, degree: 45, vertical idler face width: 610mm, horizontal idler face width: 178mm, assembly length: 657 mm; drawing no: BTS 009, D; 1650 BW
- 4.7 Return idlers shall be supplied in made up strings with 2 rolls and 3 link plates with reference to drawings A1S078030 & A3 SBH 2112.; DRG: BTS 033.
- 4.8 Idler assembly, conveyor; type: return roller strings; DRG no. A3SBH2046-/B, DRG no. A1S078030-/D and DRG no. SBH2112-/A (for links) to be assembled as one return roller assembly.
- 4.9 Rubber rings shall be as designated in the drawings. Retaining rings shall be 8 mm round bars.
- 4.10 Links bolts and link plates shall be as indicated on drawing A3SHB 2112. The plates shall be hot dipped galvanized. Links bolts & nuts shall be stainless steel.
- 4.11 The idler shafts (Series 25, 30 & 40) shall be of material SABS 1431 Grade 350WA or as otherwise indicated on the drawings.
- 4.12 Tube wall thickness shall be a minimum of 4.5mm for SABS Grade 350WA & 4mm for 3CR12. Construction of the idler shall be such that the material or water cannot settle on the end surface and enter the idler. SANS 657-3
- 4.13 End caps shall be pressed from 4mm SABS 1431 GRADE 350 WA or 3.5mm 3CR12 plates.
- 4.14 The bearing housings must be a turn back housing to centralize the two-end bearing housing for alignment of the bearings.
- 4.15 Only double seal, sealed for life, deep groove ball bearing shall be used. Bearings must be retained with a circlip on the shaft. Table 1 represents the respective bearing designation to be used for the relevant sizes of return idlers.

4.16 Table 1 Bearing designation

Shaft	Bearing Designation
Series 25 – (∅25)	6305-2RS1
	6305-2RSR

Series 40 – (S40)	6308-2RS1
	6308-2RSR

4.17 A combination of an inner double lip oil seal and outer labyrinth seal shall be provided. Tenders to indicate on a drawing the arrangement used.

4.18 Corrosion protection:

4.18.1 Preparation of Rollers: All external surfaces of the steel rollers must be Clean, Dry and free from Grease, Oil, Moisture, Rust and loose Debris.

4.18.2 Remove excessive scale / spatter from welding areas.

4.18.3 Remove oil, grease and contaminants using a degreaser.

4.18.4 Coating: Apply one coat of zinc phosphate primer and topcoat by means of automated electrostatic process to all external surfaces. Any other method of painting must be submitted to Transnet Port Terminals Saldanha for approval.

4.18.5 Special Instructions: Minimum dry film thickness: 20 microns. All coated surfaces to be touch dry prior to packaging. Standard colour to be used shall be green. Any marks that occur during transportation at delivery will be overpainted at suppliers' cost.

4.19 Testing of idlers:

4.19.1 During the manufacturing process a certain number (according to SABS1313) of idlers will be taken for testing and verifying of dimensions. Tenderers to provide optional prices for having the tests done by SABS PART 1 & 3.

4.19.2 BTS reserves the right to inspect any repair or testing processes at any time, or to request tests to be repeated at the cost of the contractor.

4.19.3 Free access to the company's works shall be given to TPT Quality department at reasonable times, and one weeks' notice is to be given by the company prior to the commencement of the fabrication, so that a representative of BTS may be present if required.

4.19.4 The service provider shall provide qualified labour and approved test equipment and facilities for tests. If facilities are not available on the Contractor's premises the contractor shall arrange for tests to be conducted by the SABS at the Contractor's cost.

- 4.19.5 All rollers supplied to TPT by a new/first time supplier shall first be tested in operation for a minimum of 100 operating hours to see if its performance is as per the TPT Saldanha Iron ore terminal requirements, i.e. fit for purpose before final approval / acceptance is given.
- 4.20 Material control:
- 4.20.1 The service provider shall provide copies of the material certificates demonstrating that the material meets the requirements of this specification.
- 4.21 Required documentation:
- 4.21.1 Before commencing with fabrication, the supplier shall provide a quality control plan to TPT to decide on hold points and inspection points.
- 4.21.2 Copies of all test certificates and type of tests according to SABS 1313 Part 1 & 3.
- 4.21.3 Certificates to be signed off by a TPT representative to confirm the design of the idler before commencing with manufacturing.
- 4.22 Packaging & shipping:
- 4.22.1 The service provider shall ensure that the idlers are packaged for shipping and storage as follows:
- 4.22.2 If heavier than 35kg, to be attached to a pallet that can be lifted by a forklift.
- 4.22.3 If not totally enclosed, to be over wrapped, sealed and provided with desiccant. The desiccant shall be placed at a location where it can be readily seen and be easily changed when it has reached its saturation point.
- 4.22.4 Any additional BTS packaging requirements will accompany the tender document.

5. QUALITY AND SERVICE

- 5.1 All services supplied and delivered to Transnet must be of excellent quality in compliance with the specifications. Should the goods or service(s) not be in conformity with the specifications, Transnet reserves the right to reject them, obtain the goods or service(s) from other sources of its free choice and debit the difference in cost, if any, to the Service Provider.
- 5.2 The Service Provider shall be fully responsible to Transnet for the acts and omissions of persons directly or indirectly employed by them.
- 5.3 The Service Provider must have roadworthy and licenced vehicles.

5.4 The Service Provider must have a permanently manned telephone (place of business/cell phone) and email access, to ensure that immediate contact can be made in case of emergency.

6. GENERAL SAFETY AND COMPLIANCE SPECIFICATIONS

- The Contractor must submit a detailed Contractor Execution Plan (CEP) to the Contractor Manager for approval as per **TRN-IMS-GRP-GDL 014.5 Contractor Execution Plan minimum requirements.**
- Contractor must submit **TRN-IMS-GRP-TMP 014.3 Employee Personal Profile Dossier** to contractor Manager for approval before induction training confirmed. Approved Employee Profile Dossiers includes certified copies of medicals, identity documents, competencies etc. submitted via email correspondence to **TPTSLD-Induction-booking@transnet.net.**
- Contractor Compliance SHE File within accordance with File Contractor Compliance in line with relevant applicable specifications as per respective **TRN-IMS-GRP-GDL 014.2 Contractor Specification Guidelines, TRN-IMS-GRP-GDL 014.4 Contractor Environmental and Sustainable Specification Guideline, TRN-IMS-GRP-GDL 014.6 Contractor Quality Specification Guideline** and **TRN-IMS-GRP-GDL 014.5 Contractor Security Specification Guidelines**
- Principle contractor approve **Mandatory Agreement** in terms of **section 37(2) TRN-IMS-GRP-TMP-014.1** of the Occupational Health and Safety Act (OHS Act) and submit to Contractor Manager to agree.
- The Principle Contractor must **submit written request** to the Contractor Manager for permission for sub-contract to provide any work or services to TPT and ensure that all **37.2 Agreement between Principle contractor and Sub Contractor** submitted to Contractor Manager.
- Contractor must **submit** completed **SHE File Electronic** to Contractor Manager for approval.
- Contractor undergoes induction training prior to handing over the site to the Contractor as **TRN-IMS-GRP-GDL 014.6 Contractor Induction Minimum Requirements.**
- **SITE ESTABLISHMENT:**
All relevant permits and authorisations is as per **TRN-IMS-GRP-TMP 014.7 List of Legal Permits and Authorisations** shared and completed prior to site access. **Contractor appointed** within accordance with **TRN-IMS-GRP-TMP-001.1** prior to site access by TPT.
- Contractor Manager will conduct **TRN-IMS GRP TMP 014.8 Pre-site handover inspection** prior to Site Access grated with Service Provider.
- **No work will commence with approved TRN-IMS-GRP-TMP-014.10 Operational Safe Work Permit** issue to the contractor by Contractor Manager.

- CLOSE OUT PHASE
Contractor Manager and the Contractor must co-sign the **TRN-IMS-GRP-TMP-014.13 Final Handover and Closeout Inspection Checklist.**
- TESTING AND COMMISSIONING:
The Contractor Manager will **develop a test and commissioning plan of the project** and communicate it to the contractor.
- The service provider will be responsible for obtaining Hot work permit from TNPA (phone no: 022 703 4331) within conjunction with Fire Safety Management Manual GRM/SHEQ/MAN 001.
- The service provider must have a Fire watch on duty during Hot Work and a Fire extinguisher as per required within Fire Safety Management Manual GRM/SHEQ/MAN 001.
- Service provider will ensure compliance to **TPT SLDT SHEQ-RS PRO 021_Lock Out Procedure** and lock out and isolation done by Trained and competent employees with conjunction with TPT competent.
- Service provider shall implement and maintain applicable Health, Safety, Quality and Environmental regulations and other relevant standards and regulation, example: applicable SANS codes; OHS Act of 1993 , other legislation, ISO 9001, ISO 14001 and ISO 45001, etc.
- Service provider to ensure that all employees involved in activity is informed of the Hazards and risk they exposed to and all other relevant applicable Safety Work Procedures, Fall protections Plans, Environmental Plans, Emergency Plans and any other relevant procedures, etc. proof to be submitted as part of the SHE File.
- Service Provider will ensure that On the Job HIRAS is completed prior to start of activity to ensure that any additional Risks been identified.
- Service provider must ensure that when required to off-load or load any heavy equipment and machinery on the plant that they comply with that equipment or machinery will not be physically operated by an employee when required to off-loaded or load from any flatbed or low bed.
- Principle Contractor will be responsible to ensure that Sub Contractor SHE File compiled within conjunction with TPT Requirements and Approved prior to submission to Contractor Manager.
- Service Providers are liable to collect and remove all waste generated during the contract/project. Generated Waste will not allowed being disposed within TPT waste skips. Removal of Hazardous waste will be contractor's responsibility and Disposal Certificate submitted to SHEQ after waste has been disposed safely.

Contact the following employees at SHERQ Department:

SHERQ Manager: Werner Labuschagne



Email: Werner.Labuschagne@transnet.net

Contact number: 022 703 4945

SHERQ Manager IOT: Marlon Saayman

Email: marlon.saayman@transnet.net

Contact number: 022 703 4958

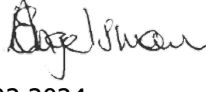
Compiled by: Name: Siphhelele Bolitshi Signature:  Date: 05.02.2024	Reviewed by: Engineering Manager Name: Ebrahim Jacobs Signature:  Date: 05.02.2024
Approved by: Senior Engineering Manager Name: Carols Engelsman Signature:  Date: 05.02.2024	

**ANNEXURE B****SBD 6.2****DECLARATION CERTIFICATE FOR LOCAL PRODUCTION AND CONTENT FOR DESIGNATED SECTORS**

This Standard Bidding Document (SBD) must form part of all bids invited. It contains general information and serves as a declaration form for local content (local production and local content are used interchangeably).

Before completing this declaration, bidders must study the General Conditions, Definitions, Directives applicable in respect of Local Content as prescribed in the Preferential Procurement Regulations, 2017, the South African Bureau of Standards (SABS) approved technical specification number SATS 1286:2011 (Edition 1) and the Guidance on the Calculation of Local Content together with the Local Content Declaration Templates [Annex C (Local Content Declaration: Summary Schedule), D (Imported Content Declaration: Supporting Schedule to Annex C) and E (Local Content Declaration: Supporting Schedule to Annex C)].

1. General Conditions

- 1.1. Preferential Procurement Regulations, 2017 (Regulation 8) makes provision for the promotion of local production and content.
- 1.2. Regulation 8.(2) prescribes that in the case of designated sectors, where in the award of bids local production and content is of critical importance, such bids must be advertised with the specific bidding condition that only locally produced goods, services or works or locally manufactured goods, with a stipulated minimum threshold for local production and content will be considered.
- 1.3. In terms of Regulation 16(2) of the Preferential Procurement Regulations, 2017, any sector designated and minimum threshold determined for local production and content for purposes of regulation 9 of the 2011 Regulations and in force immediately before the repeal of the 2011 Regulations, are regarded as having been done under regulation 8(1) of the 2017 Regulations.
- 1.4. Where necessary, for bids referred to in paragraph 1.2 above, a two stage bidding process may be followed, where the first stage involves a minimum threshold for local production and content and the second stage price and B-BBEE.
- 1.5. A person awarded a contract in relation to a designated sector, may not sub-contract in such a manner that the local production and content of the overall value of the contract is reduced to below the stipulated minimum threshold.
- 1.6. The local content (LC) expressed as a percentage of the bid price must be calculated in accordance with the SABS approved technical specification number SATS 1286: 2011 as follows:

$$LC = [1 - x / y] * 100$$

Where

x is the imported content in Rand

y is the bid price in Rand excluding value added tax (VAT)

Prices referred to in the determination of x must be converted to Rand (ZAR) by using the exchange rate published by South African Reserve Bank (SARB) at 12:00 on the date of advertisement of the bid as indicated in paragraph 4.1 below.

The SABS approved technical specification number SATS 1286:2011 is accessible on [http://www.thedti.gov.za/industrial development/ip.jsp](http://www.thedti.gov.za/industrial%20development/ip.jsp) at no cost.

- 1.7. A bid will be disqualified if this Declaration Certificate and the Annex C (Local Content Declaration: Summary Schedule) are not submitted as part of the bid documentation;

2. The stipulated minimum threshold(s) for local production and content (refer to Annex A of SATS 1286:2011) for this bid is/are as follows:

<u>Description of services, works or goods</u>	<u>Stipulated minimum threshold</u>
Bulk Material Handling	85%
Conveyer Idlers	70%
Structural Steel	100 %

Rubber	100 %
Conveyer Belt	100 %
Pulleys	60%

4. Does any portion of the services, works or goods offered have any imported content?
(Tick applicable box)

YES	<input type="checkbox"/>	NO	<input type="checkbox"/>
-----	--------------------------	----	--------------------------

- 4.1 If yes, the rate(s) of exchange to be used in this bid to calculate the local content as prescribed in paragraph 1.5 of the general conditions must be the rate(s) published by SARB for the specific currency at 12:00 on the date of advertisement of the bid.

The relevant rates of exchange information is accessible on www.reservebank.co.za

Indicate the rate(s) of exchange against the appropriate currency in the table below (refer to Annex A of SATS 1286:2011):

Currency	Rates of exchange
US Dollar	
Pound Sterling	
Euro	
Yen	
Other	

NB: Bidders must submit proof of the SARB rate (s) of exchange used.

5. Where, after the award of a bid, challenges are experienced in meeting the stipulated minimum threshold for local content the dti must be informed accordingly in order for the dti to verify and in consultation with the AO/AA provide directives in this regard.

LOCAL CONTENT DECLARATION
(REFER TO ANNEX B OF SATS 1286:2011)

LOCAL CONTENT DECLARATION BY CHIEF FINANCIAL OFFICER OR OTHER LEGALLY RESPONSIBLE PERSON NOMINATED IN WRITING BY THE CHIEF EXECUTIVE OR SENIOR MEMBER/PERSON WITH MANAGEMENT RESPONSIBILITY (CLOSE CORPORATION, PARTNERSHIP OR INDIVIDUAL)

IN RESPECT OF BID NO. TPT/2024/02/0030/56812/RFP

ISSUED BY: TRANSNET SOC LTD

NB

- 1 The obligation to complete, duly sign and submit this declaration cannot be transferred to an external authorized representative, auditor or any other third party acting on behalf of the bidder.
- 2 Guidance on the Calculation of Local Content together with Local Content Declaration Templates (Annex C, D and E) is accessible on http://www.thdti.gov.za/industrial_development/ip.jsp. Bidders should first complete Declaration D. After completing Declaration D, bidders should complete Declaration E and then consolidate the information on Declaration C. **Declaration C should be submitted with the bid documentation at the closing date and time of the bid in order to substantiate the declaration made in paragraph (c) below.** Declarations D and E should be kept by the bidders for verification purposes for a period of at least 5 years. The successful bidder is required to continuously update Declarations C, D and E with the actual values for the duration of the contract.

I, the undersigned, (full names), do hereby declare, in my capacity asof.....(name of bidder entity), the following:

- (a) The facts contained herein are within my own personal knowledge.
- (b) I have satisfied myself that:
 - (i) the goods/services/works to be delivered in terms of the above-specified bid comply with the minimum local content requirements as specified in the bid, and as measured in terms of SATS 1286:2011; and
- (c) The local content percentage (%) indicated below has been calculated using the formula given in clause 3 of SATS 1286:2011, the rates of exchange indicated in paragraph 4.1 above and the information contained in Declaration D and E which has been consolidated in Declaration C:

Bid price, excluding VAT (y)	R
Imported content (x), as calculated in terms of SATS 1286:2011	R
Stipulated minimum threshold for local content (paragraph 3 above)	
Local content %, as calculated in terms of SATS 1286:2011	

If the bid is for more than one product, the local content percentages for each product contained in Declaration C shall be used instead of the table above. The local content percentages for each product has been calculated using the formula given in clause 3 of SATS 1286:2011, the rates of exchange indicated in paragraph 4.1 above and the information contained in Declaration D and E.

- (d) I accept that the Procurement Authority / Institution has the right to request that the local content be verified in terms of the requirements of SATS 1286:2011.
- (e) I understand that the awarding of the bid is dependent on the accuracy of the information furnished in this application. I also understand that the submission of incorrect data, or data that are not verifiable as described in SATS 1286:2011, may result in the Procurement Authority / Institution imposing any or all of the remedies as provided for in Regulation 14 of the Preferential Procurement Regulations, 2017 promulgated under the Preferential Policy Framework Act (PPFA), 2000 (Act No. 5 of 2000).

SIGNATURE: _____ **DATE:** _____

WITNESS No. 1 _____ **DATE:** _____

WITNESS No. 2 _____ **DATE:** _____

Annex C

MANDATORY RETURNABLE DOCUMENT:

FAILURE TO FULLY COMPLETE, DECLARE, SIGN & DATE THIS ANNEXURE C WILL RESULT IN THE BID BEING NON-RESPONSIVE & DISQUALIFIED

Local Content Declaration - Summary Schedule

- (C1) Tender No.
(C2) Tender description:
(C3) Designated product(s)
(C4) Tender Authority:
(C5) Tendering Entity name:
(C6) Tender Exchange Rate:
(C7) Specified local content %

Note: VAT to be excluded from all calculations

Pula EU GBP

Calculation of local content							
Tender item no's	List of items	Tender price - each (excl VAT)	Exempted imported value	Tender value net of exempted imported content	Imported value	Local value	Local content % (per item)
(C8)	(C9)	(C10)	(C11)	(C12)	(C13)	(C14)	(C15)

Tender summary			
Tender Qty	Total tender value	Total exempted imported content	Total Imported content
(C16)	(C17)	(C18)	(C19)

Signature of tenderer from Annex B

Date: _____

(C20) Total tender value	R 0
(C21) Total Exempt imported content	R 0
(C22) Total Tender value net of exempt imported content	R 0
(C23) Total Imported content	R 0
(C24) Total local content	R 0
(C25) Average local content % of tender	

Annex D

ESSENTIAL RETURNABLE DOCUMENT:
FAILURE TO FULLY COMPLETE, DECLARE, SIGN & DATE THIS ANNEXURE D MAY RESULT IN THE BID BEING NON-RESPONSIVE & DISQUALIFIED

Imported Content Declaration - Supporting Schedule to Annex C

(D1) Tender No. _____
 (D2) Tender description: _____
 (D3) Designated Products: _____
 (D4) Tender Authority: _____
 (D5) Tendering Entity name: _____
 (D6) Tender Exchange Rate: Pula _____

Note: VAT to be excluded from all calculations

EU R 9.00 GBP R 12.00

A. Exempted imported content

Calculation of imported content										Summary	
Tender item no's	Description of imported content	Local supplier	Overseas Supplier	Foreign currency value as per Commercial Invoice	Tender Exchange Rate	Local value of imports	Freight costs to port of entry	All locally incurred landing costs & duties	Total landed cost excl VAT	Tender Qty	Exempted imported value
(D7)	(D8)	(D9)	(D10)	(D11)	(D12)	(D13)	(D14)	(D15)	(D16)	(D17)	(D18)
(D19) Total exempt imported value										R 0	

This total must correspond with Annex C - C 21

B. Imported directly by the Tenderer

Calculation of imported content										Summary	
Tender item no's	Description of imported content	Unit of measure	Overseas Supplier	Foreign currency value as per Commercial Invoice	Tender Rate of Exchange	Local value of imports	Freight costs to port of entry	All locally incurred landing costs & duties	Total landed cost excl VAT	Tender Qty	Total imported value
(D20)	(D21)	(D22)	(D23)	(D24)	(D25)	(D26)	(D27)	(D28)	(D29)	(D30)	(D31)
(D32) Total imported value by tenderer										R 0	

C. Imported by a 3rd party and supplied to the Tenderer

Calculation of imported content										Summary	
Description of imported content	Unit of measure	Local supplier	Overseas Supplier	Foreign currency value as per Commercial Invoice	Tender Rate of Exchange	Local value of imports	Freight costs to port of entry	All locally incurred landing costs & duties	Total landed cost excl VAT	Quantity imported	Total imported value
(D33)	(D34)	(D35)	(D36)	(D37)	(D38)	(D39)	(D40)	(D41)	(D42)	(D43)	(D44)
(D45) Total imported value by 3rd party										R 0	

D. Other foreign currency payments

Calculation of foreign currency payments					Summary of payments	
Type of payment	Local supplier making the payment	Overseas beneficiary	Foreign currency value paid	Tender Rate of Exchange	Local value of payments	
(D46)	(D47)	(D48)	(D49)	(D50)	(D51)	
(D52) Total of foreign currency payments declared by tenderer and/or 3rd party					R 0	

Signature of tenderer from Annex B _____
 Date: _____

(D53) Total of imported content & foreign currency payments - (D32), (D45) & (D52) above R 0
 This total must correspond with Annex C - C 23

Annex E

**ESSENTIAL RETURNABLE DOCUMENT:
FAILURE TO FULLY COMPLETE, DECLARE, SIGN & DATE THIS ANNEXURE E MAY RESULT IN THE BID BEING NON-RESPONSIVE & DISQUALIFIED**

Local Content Declaration - Supporting Schedule to Annex C

(E1)	Tender No.	
(E2)	Tender description:	
(E3)	Designated products:	
(E4)	Tender Authority:	
(E5)	Tendering Entity name:	

Note: VAT to be excluded from all calculations

Local Products (Goods, Services and Works)	Description of items purchased	Local suppliers	Value
	(E6)	(E7)	(E8)
(E9) Total local products (Goods, Services and Works)			R 0

(E10) **Manpower costs** (Tenderer's manpower cost) R 0

(E11) **Factory overheads** (Rental, depreciation & amortisation, utility costs, consumables etc.) R 0

(E12) **Administration overheads and mark-up** (Marketing, insurance, financing, interest etc.) R 0

(E13) Total local content R 0

This total must correspond with Annex C - C24

Signature of tenderer from Annex B

Date: _____

ANNEXURE A - LIST OF CARRYING AND RETURN ROLLERS

MM No.	Type	Short Description	Long Description	Drawing No. BTS	Quantities
130183	Carrying Idler	Carrying Idler 370mm Roll Face	Conveyor Carrying Idler Type: Carrying Through Idler - Fixed Idler Diameter: 152mm Shaft Diameter: 30mm (Series 30) Overall Shaft Length: 417mm Belt Width: 1650 Func.Loc.: S/L 1&2, S/R 1-3 Drawing No.: A3SBH2132	A3SBH2132	4500
131074	Carrying Idler	Carrying Idler 400mm Roll Face	Conveyor Carrying Idler Type: Carrying Through Idler - Fixed Idler Diameter: 34mm Overall Shaft Length: 444mm Belt Width: 1650 Func.Loc.: S/R 1-3 Drawing No.: A3SBH2141	A3SBH2141	3000
134970	Carrying Idler	Carrying Idler 160mm Roll Face	Conveyor Carrying Idler Type: Steel Impact Carrying Idler Idler Diameter: 152mm Shaft Diameter: 30mm (Series 30) Overall Shaft Length: 207mm Belt Width: 1650 Func.Loc.: CV 109 Drawing No.: BTS 030	BTS 030	300
138505	Carrying Idler	Carrying Idler 600mm Roll Face	Conveyor Carrying Idler Type: Through, Retractable, Training, & Rigid Suspended Idler Idler Diameter: 152mm Shaft Diameter: 30mm (Series 30) Overall Shaft Length: 647mm Belt Width: 1650 Func.Loc.: Drawing No.: BTS 011	BTS 011	450
138509	Carrying Idler	Carrying Idler 610mm Roll Face	Conveyor Carrying Idler Type: Garland Carrying Idler String - Quick Release Brackets Idler Diameter: 178mm Shaft Diameter: 40mm (Series 40) Overall Shaft Length: 680mm Belt Width: 1650 Func.Loc.: Drawing No.: BTS 010 (Sheet 1 & 2)	BTS 010 (Sheet 1 & 2)	300
165856	Carrying Idler	Carrying Idler 340mm Roll Face	Conveyor Carrying Idler Type: Steel Impact Carrying Idler Idler Diameter: 152mm Shaft Diameter: 30mm (Series 30) Overall Shaft Length: 387mm Belt Width: 1650 Func.Loc.: Drawing No.: BTS 031	BTS 031	450
138513	Carrying Idler	Carrying Idler 660mm Roll Face	Conveyor Carrying Idler Type: Through, Retractable, Training, & Rigid Suspended Idler Idler Diameter: 152mm Shaft Diameter: 30mm (Series 30) Overall Shaft Length: 707mm Belt Width: 1650 Func.Loc.: Drawing No.: BTS 012	BTS 012	600
138512	Carrying Idler	Carrying Idler 610mm Roll Face	Conveyor Carrying Idler Type: Through & Underslung Idler 45 degrees Idler Diameter: 178mm Shaft Diameter: 40mm (Series 40) Overall Shaft Length: 657mm Belt Width: 1650 Func.Loc.: Drawing No.: BTS 009	BTS 009	12000
130194	Carrying Idler	Carrying Idler 308mm Roll Face	Conveyor Carrying Idler Type: Carrying Idler - Garland Idler Diameter: 152mm Shaft Diameter: 30mm (Series 30) Overall Shaft Length: 368mm Belt Width: 1650 Func.Loc.: S/L 1&2 Drawing No.: A3SBH2131	A3SBH2131	300
124772	Carrying Idler	HDPE Idler 370mm Roll Face	Conveyor Carrying Idler Type: Idler HDPE 370mm Roll Face Idler Diameter: 152mm Shaft Diameter: 30mm (Series 30) Overall Shaft Length: 417mm	BTS 040	90

			Belt Width: 1650 Func.Loc.: CV 114 Impact Station Drawing No.: BTS 040		
130231	Carrying Idler	Carrying Idler 370mm Roll Face	Conveyor Carrying Idler Type: Fixed Impact Carry Idler - Rubber Idler Diameter: 159mm Shaft Diameter: 30mm (Series 30) Overall Shaft Length: 420mm Belt Width: 1650 Func.Loc.: CV 114 Impact Station Drawing No.: A3SBH2136	A3SBH2136	400
131075	Carrying Idler	Carrying Idler 400mm Roll Face	Conveyor Carrying Idler Type: Fixed Impact Carry Idler - Rubber Idler Diameter: 150mm Shaft Diameter: 30mm (Series 30) Overall Shaft Length: 448mm Belt Width: 1800 Func.Loc.: S/R 1-3 Drawing No.: A3SBH2143	A3SBH2143	300
131072	Carrying Idler	Carrying Idler 370mm Roll Face	Conveyor Carrying Idler Type: Rubber Carrying Idler 370 Roll Face Idler Diameter: 150mm Shaft Diameter: 30mm (Series 30) Overall Shaft Length: 418mm Belt Width: 1650 Func.Loc.: S/R 1-3, Tripper Conveyor Drawing No.: BTS 038	BTS 038	450
118536	Carrying Idler	Carrying Idler 340mm Roll Face	Conveyor Carrying Idler Type: Steel Balanced Carrying Roll - Fixed Idler Diameter: 152mm Shaft Diameter: 30mm (Series 30) Overall Shaft Length: 366mm Belt Width: 1650 Func.Loc.: Conveyor Scale Drawing No.: A3SBH2097 Supply Balance Certificate	A3SBH2097	1200
134110	Carrying Idler	Scale Idler 400mm Roll Face	Conveyor Carrying Idler Type: Steel Balanced Scale Idler Idler Diameter: 152mm Shaft Diameter: 30mm (Series 30) Overall Shaft Length: 434mm Belt Width: 1800 Func.Loc.: S/R 1 - 3, Conveyor Scale Drawing No.: BTS 036 Supply Balance Certificate	BTS 036	300
134123	Carrying Idler	Scale Idler 340mm Roll Face	Conveyor Carrying Idler Type: Steel Balanced Scale Idler Idler Diameter: 152mm Shaft Diameter: 30mm (Series 30) Overall Shaft Length: 378mm Belt Width: 1650 Func.Loc.: CV 209 Conveyor Scale Drawing No.: BTS 037 Supply Balance Certificate	BTS 037	150
141201	Carrying Idler	Scale Idler 340mm Roll Face	Conveyor Carrying Idler Type: Steel Balanced Scale Idler Idler Diameter: 152mm Shaft Diameter: 40mm (Series 40) Overall Shaft Length: 697mm Belt Width: 1800 Func.Loc.: S/R4 Boom Conveyor Scale Drawing No.: SBHS 5040 Supply Balance Certificate	SBHS 5040	600
131075	Carrying Idler	Rubber Impact Idler 400mm Roll	Conveyor Fixed Impact Carrying Idler - Rubber Type: Rubber Impact Idler Idler Diameter: 150mm Shaft Diameter: 30mm (Series 30) Overall Shaft Length: 448mm Belt Width: 1800 Func.Loc.: S/R1-3 Drawing No.: A3 SBHS 2143	A3 SBHS 2143	300
134110	Carrying Idler	Scale Idler	Conveyor Carrying Idler Type: Steel Balanced Scale Idler Idler Diameter: 152mm Shaft Diameter: 30mm (Series 30) Overall Shaft Length: 434mm Belt Width: 1800 Func.Loc.: S/R1-3 Drawing No.: BTS 036 Supply Balance Certificate	BTS 036	300

145250	Carrying Idler	Carrying Idler 326mm Roll Face	Conveyor Carrying Idler Type: Impact Idler Idler Diameter: 178mm Shaft Diameter: 40mm (Series 40) Overall Shaft Length: 387m		300
145251	Carrying Idler	Carrying Idler 226mm Roll Face	Conveyor Carrying Idler Type: Rubber Impact Idler Idler Diameter: 178mm Shaft Diameter: 40mm (Series 40) Overall Shaft Length: 287m Belt Width: 1650 Func.Loc.: CV113 & CV213 tail; CV114 & CV214 tail		600
118534	Carrying Idler	Carrying Idler 340mm Roll Face	Conveyor Carrying Idler Type: Steel Idler Idler Diameter: 152mm Shaft Diameter: 50mm Overall Shaft Length: Belt Width: 1650 Func.Loc.:	SBH 2112	150
150542	Carrying Idler	Carrying Idler 270mm Roll Face	Conveyor Carrying Idler Type: Galvanised Steel Impact Idler Idler Diameter: 150mm Shaft Diameter: 30mm Overall Shaft Length: 317 Belt Width: Func.Loc.: CV314	BTS 073	90
141201	Carrying Idler	Carrying Idler 660mm Roll Face	Conveyor Carrying Idler Type: Balanced Boom Scale Idler, 45 degrees Idler Diameter: 152mm Shaft Diameter: Overall Shaft Length: 697mm Belt Width: 1800 Func.Loc.: S/R4 Boom Conveyor Scale Drawing No.: SBHS 5040 Supply Balance Certificate	SBHS 5040	60
151163	Self-trainer Idler	Carrying Idler 885mm Roll Face	Conveyor Self-trainer Idler Type: Polyurethane Idler Idler Diameter: 152mm Shaft Diameter: 30mm Overall Shaft Length: 895mm Belt Width: Func.Loc.: Ship Loader Boom Conveyor		30
151481	Carrying Idler	Rubber Impact Idler	Conveyor Carrying Idler Type: Rubber Impact Idler Idler Diameter: 127mm Shaft Diameter: 30mm Overall Shaft Length: 414mm Belt Width: Func.Loc.: Ship Loader Boom Conveyor		30
130230	Return Idler	Return Idler 1754mm Roll Face	Conveyor Return Idler Type: Flat Return Idler - 1 Roll Idler Diameter: 152mm Shaft Diameter: 40mm (Series 40) Overall Shaft Length: 1799mm Belt Width: 1650 Func.Loc.: S/L 1&2 Drawing No.: A3SBH2133	A3SBH2133	60
130192	Return Idler	Return Idler 885mm Roll Face	Conveyor Return Idler Type: Flat Return Idler - Fixed Idler Diameter: 152mm Shaft Diameter: 40 (Series 40) Overall Shaft Length: 933mm Belt Width: 1650 Func.Loc.: S/L 1&2 Drawing No.: A3SBH2134	A3SBH2134	180
138510	Return Idler	Return Idler 885mm Roll Face	Conveyor Return Idler Type: Flat Return&V-Return Idler - S25-2Roll-1650BW Idler Diameter: 152mm Shaft Diameter: 25 (Series 25) Overall Shaft Length: 929mm Belt Width: 1650 Func.Loc.: Drawing No.: BTS 017	BTS 017	600
138506	Return Idler	Return Idler 900mm Roll Face	Conveyor Return Idler Type: Garland V-Return Idler - S-25-1650BW Idler Diameter: 152mm Shaft Diameter: 25 (Series 25) Overall Shaft Length: 960mm Belt Width: 1650 Func.Loc.:	BTS 018 (Sheet 1 & 2)	1500

Drawing No.: BTS 018 (Sheet 1 & 2)					
152026	Return Idler	Rubber Return Idler	Conveyor Return Idler Type: Rubber Return Idler Idler Diameter: 178mm Shaft Diameter: 30 (Series 30) Overall Shaft Length: Belt Width: 1650 Func.Loc.: Drawing No.:		90
143363	Return Idler	Return Idler 965mm Roll Face	Conveyor Return Idler Type: Rubber Conical Roller Idler Diameter: 582mm Shaft Diameter: Overall Shaft Length: Belt Width: Func.Loc.: Drawing No.:		30
138502	Return Idler	Rubber Conical Idler	Conveyor Return Idler Type: SR4-V- Return Idler - S30-1800BW-2Roll Idler Diameter: 152mm Shaft Diameter: 30 (Series 30) Overall Shaft Length: 1022mm Belt Width: 1800 Func.Loc.: S/R 4 Drawing No.: BTS 015	BTS 015	300
115629	Return Idler	Return Idler 1908mm Roll Face	Conveyor Return Idler Type: Steel Flat Return Idler Idler Diameter: 152mm Shaft Diameter: 40 (Series 40) Overall Shaft Length: 1955mm Belt Width: 1800 Func.Loc.: Boom Conveyor - S/R 1-3 Drawing No.: BTS 029	BTS 029	45
134971	Return Idler	Return Idler 900mm Roll Face	Conveyor Return Idler Type: Rubber V-Return Idler Idler Diameter: 178mm Shaft Diameter: 25 (Series 25) Overall Shaft Length: 944mm Belt Width: 1650 Func.Loc.: Drawing No.: BTS 032	BTS 032	3000
127584	Return Idler	Return Idler 900mm Roll Face	Conveyor Return Idler Type: Rubber V-Return Idler - Complete Idler Diameter: 178mm Shaft Diameter: 25 (Series 25) Overall Shaft Length: 960mm Belt Width: 1650 Func.Loc.: Drawing No.: BTS 033 Ref: A3SBH2046, A1S078030 & A3SBH2112 Note: Complete Assembled Roller Strings DRG:A3SBH2046 Drawing Number A1S078030&SBH2112 (For Links) Return Roller String To Be Assembled Consisting Of Two Return Rollers and Three Galvanised Link Sets with chain on both ends, 5 link chain - 13mm galv. (39x45.5)	BTS 033 Ref: A3SBH2046 A1S078030 A3SBH2112	15000
130193	Return Idler	Return Idler 886mm Roll Face	Conveyor Return Idler Type: Fixed Return Idler - Rubber Idler Diameter: 157mm Shaft Diameter: 25 (Series 25) Overall Shaft Length: 934mm Belt Width: 1650 Func.Loc.: Drawing No.: A3SBH2135	A3SBH2135	900
118530	Return Idler	Training Idler 900mm Roll Face	Conveyor Return Idler Type: Self Trainer Idler - Rubber Idler Diameter: 180mm Shaft Diameter: 25 (Series 25) Overall Shaft Length: 952mm Belt Width: 1650 Func.Loc.: Drawing No.: A3SBH2031 Ref: A3SBH2046	A3SBH2031 Ref: A3SBH2046	60
143364	Return Idler	Rubber Conical Return Idler	Conveyor Return Idler Type: Conical idler - Rubber Idler Diameter: 552mm Shaft Diameter: 30 (Series 30) Overall Shaft Length:		15

			Belt Width: 1650		
			Func.Loc.:		
			Drawing No.:		
131070	Return Idler	Return Idler 885mm Roll Face	Conveyor Return Idler	BTS 039	
			Type: Rubber Return Idler 885 Idler Face		450
			Idler Diameter: 152mm		
			Shaft Diameter: 30 (Series 30)		
			Overall Shaft Length: 933mm		
			Belt Width: 1800		
			Func.Loc.: S/R1-3		
			Drawing No.: BTS 039		

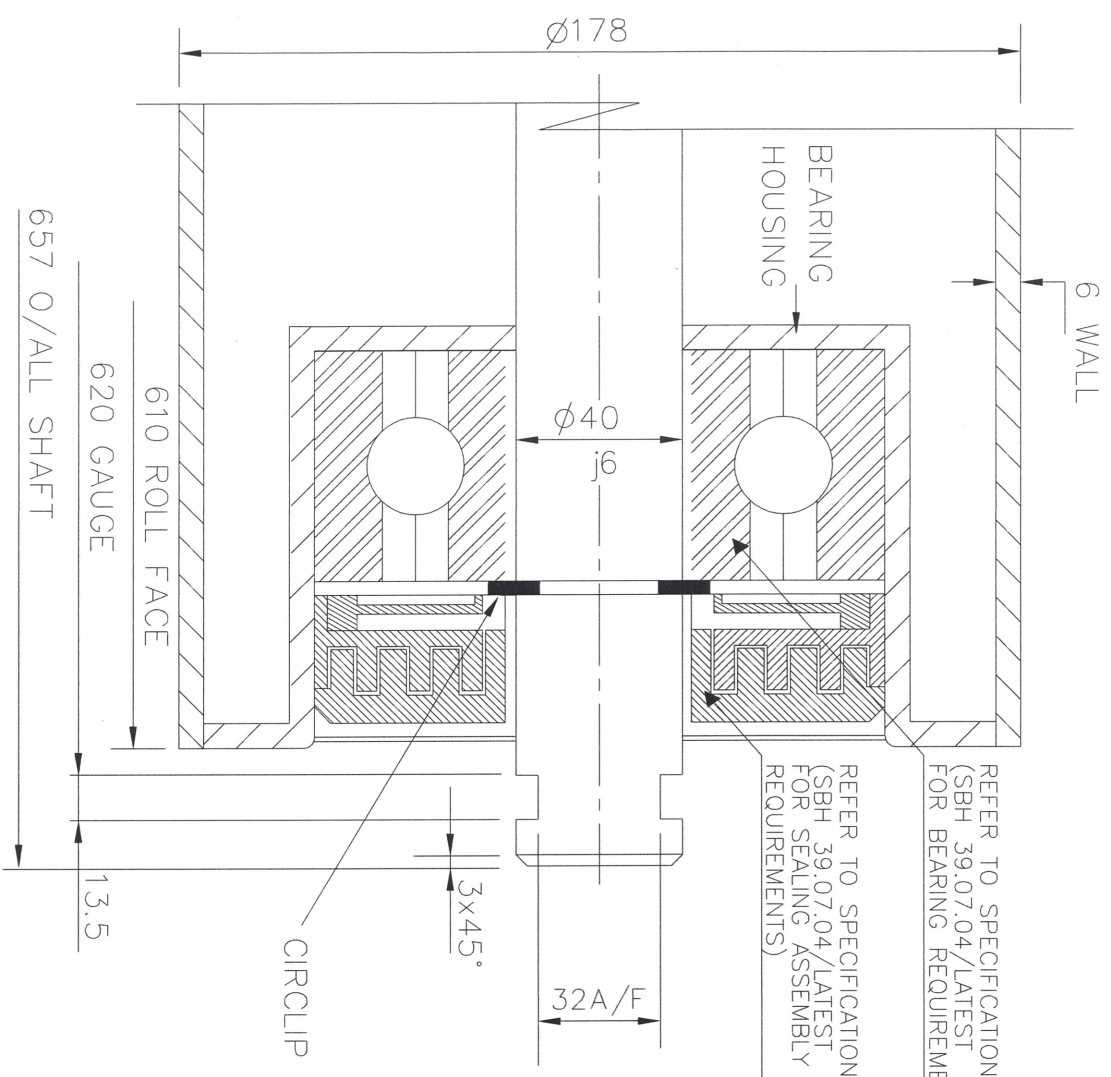



REFER TO SPECIFICATION (SBH 39.07.04/LATEST FOR BEARING REQUIREMENTS)

REFER TO SPECIFICATION (SBH 39.07.04/LATEST FOR SEALING ASSEMBLY REQUIREMENTS)

NOTE :
 IDLERS SHALL COMPLY WITH SABS 1313/LATEST AND SALDANHA BULK TERMINAL SPECIFICATION SBH 39.07.04/LATEST.

AMENDMENTS

STORES MATERIAL SAP NO.
 138512

TITLE	NAME	SIGNATURE	DATE
DRAWN	S.BOLITSHI		26/07/2012
CHECKED	P.S.VART		26/07/2012
APPROVED	N.STRYDOM		26/07/2012
PRE ENG / PR/TEC			
NAME			DATE
SIGNATURE			
REG NUMBER			

 <p>SALDANHA BULK TERMINAL</p>	
DRAWING TITLE:	
THROUGH & UNDER SLUNG IDLER	
SUBTITLE: CONVEYOR CARRYING IDLERS	
DRAWING NUMBER	PAPER SCALE / REV.
BTS 009	A3 N.T.S./A
	SHEET 1 OF 1

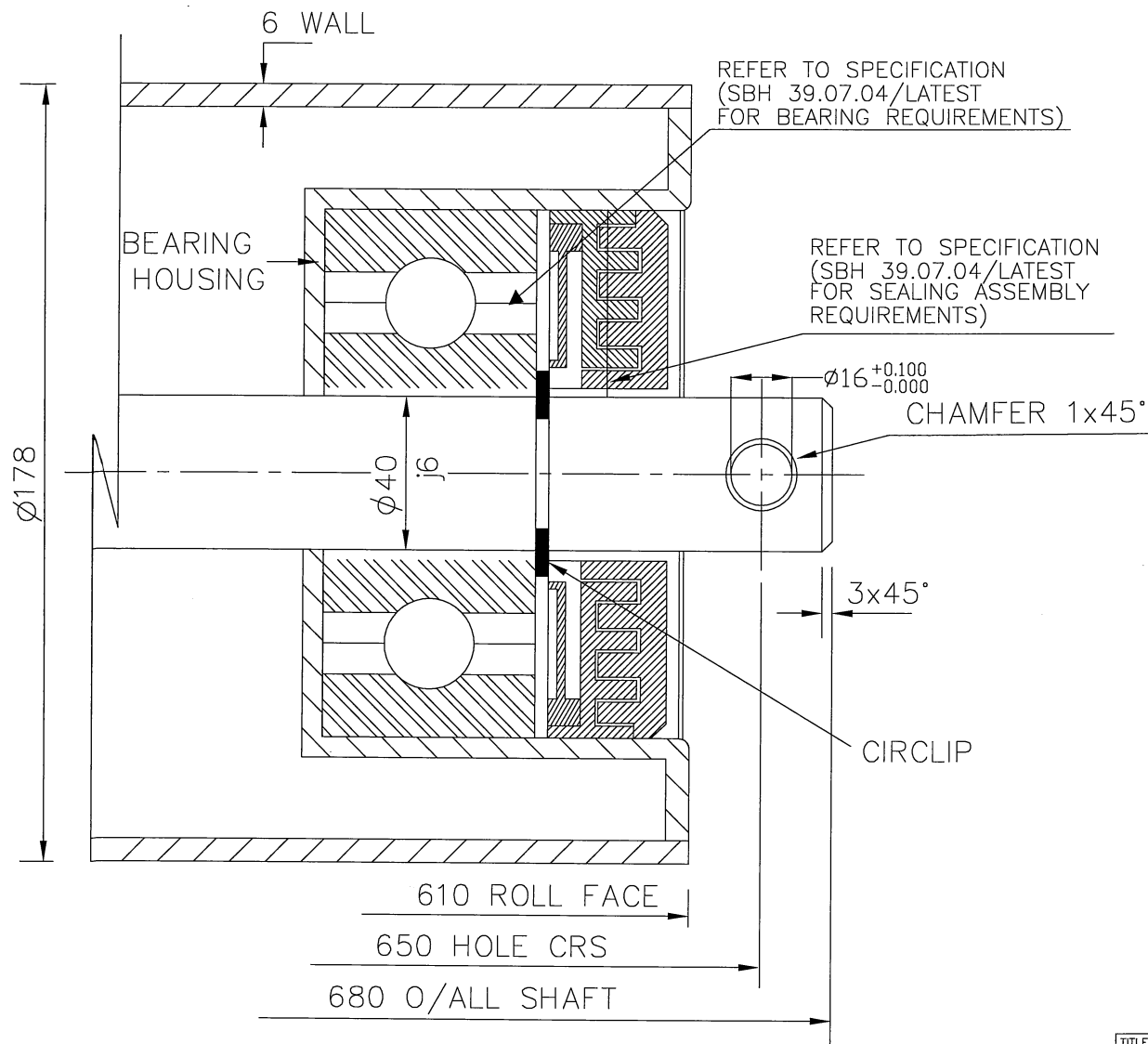





NOTE :
 IDLERS SHALL COMPLY WITH SABS 1313/LATEST
 AND SALDANHA BULK TERMINAL SPECIFICATION
 SBH 39.07.04/LATEST.

AMENDMENTS

REV B- SHEET 2 ADDED FOR PLATE AND NUT LINKS

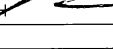
STORES MATERIAL SAP NO.
 138509

TITLE	NAME	SIGNATURE	DATE
DRAWN	S.BOLITSHI		26/07/2012
CHECKED	P.SWART		26/07/2012
APPROVED	N.STRYDOM		26/07/2012
PR.ENG / PR.TECH			DATE
NAME			
SIGNATURE			
REG.NUMBER			

 SALDANHA BULK TERMINAL			
DRAWING TITLE:			
GARLAND CARRYING IDLER STRING - QUICK RELEASE BRACKETS - 1650 BW 45° - S40			
DRAWING NUMBER	PAPER	SCALE	REV.
BTS 010	A3	N.T.S.	A B
			SHEET 1 OF 2

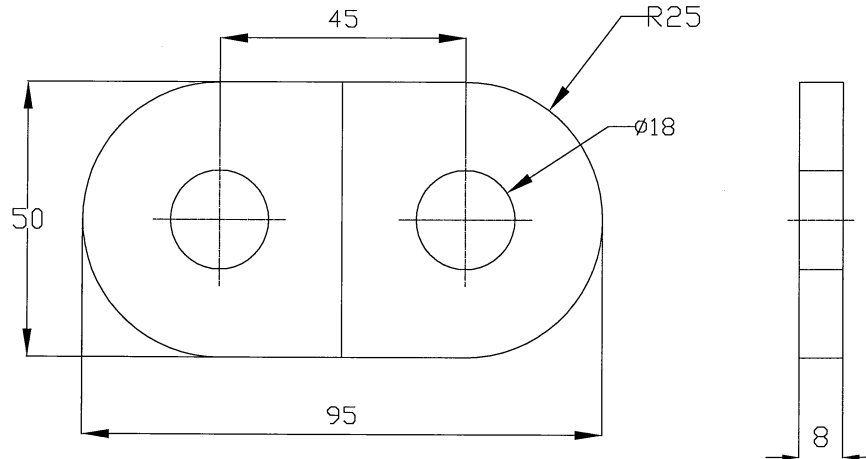

PLATE

MATERIAL: PLATE

SABS 1431 GRADE 350WA
HOT DIP GALVANISED

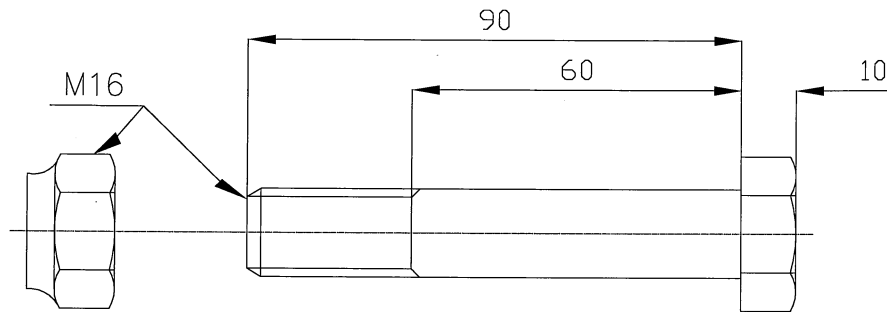

NUT



MATERIAL: NUT

STAINLESS STEEL

AMENDMENTS

REV B- SHEET 2 ADDED FOR PLATE AND NUT LINKS

STORES MATERIAL SAP NO.
138509

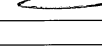
TITLE	NAME	SIGNATURE	DATE
DRAWN	S.BOLITSHI		26/07/2012
CHECKED	P.SWART		26/07/2012
APPROVED	N.STRYDOM		26/07/2012
PR.ENG / PR.TECH			
NAME			DATE
SIGNATURE			
REG.NUMBER			



SALDANHA BULK TERMINAL

DRAWING TITLE:
GARLAND CARRYING IDLER STRING - QUICK RELEASE
BRACKETS - 1650 BW 45' - S40

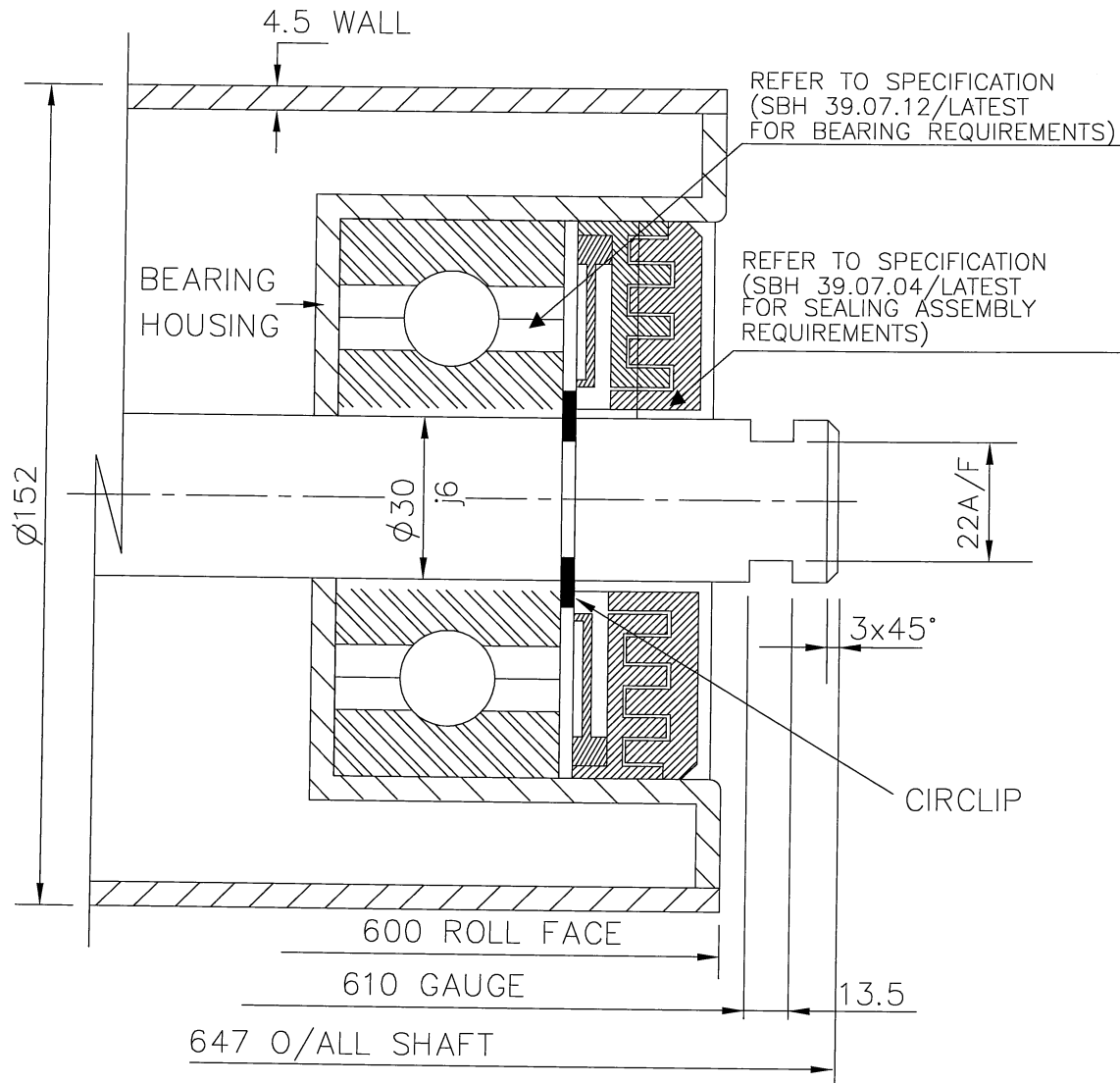

DRAWING NUMBER	PAPER	SCALE	REV.						
BTS 010	A3	N.T.S.	A	B					SHEET 2 OF 2



NOTE :
 IDLERS SHALL COMPLY WITH SABS 1313/LATEST
 AND SALDANHA BULK TERMINAL SPECIFICATION
 SBH 39.07.04/LATEST.

AMENDMENTS

STORES MATERIAL SAP NO.
 138505

TITLE	NAME	SIGNATURE	DATE
DRAWN	S.BOLITSHI		26/07/2012
CHECKED	P.SWART		26/07/2012
APPROVED	N.STRYDOM		26/07/2012
PR.ENG / PR.TECH			
NAME			DATE
SIGNATURE			
REG.NUMBER			

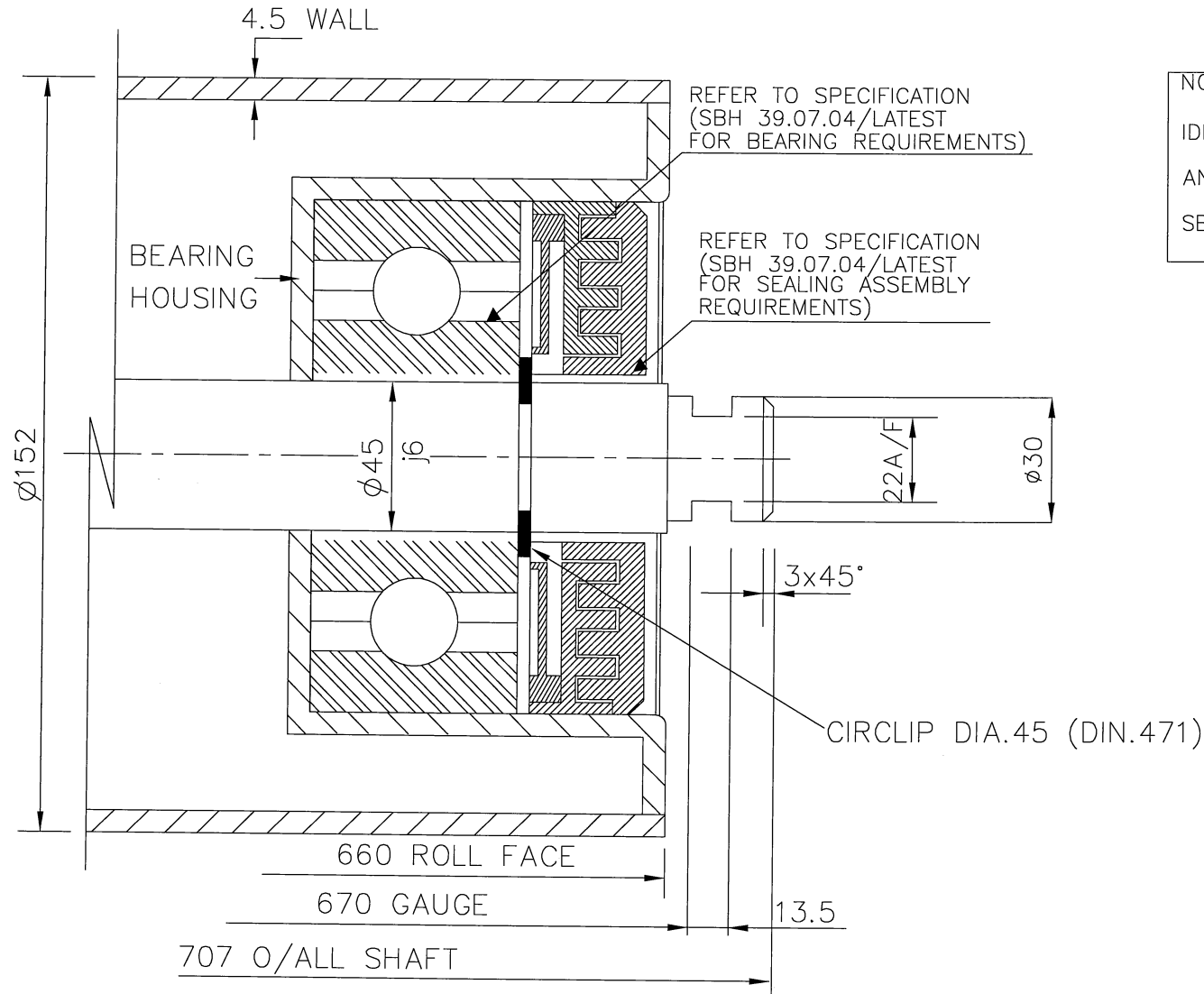

				SALDANHA BULK TERMINAL			
DRAWING TITLE:							THROUGH, RETRACTABLE, TRAINING & RIGID SUSPENDED IDLER
SUBTITLE:							CONVEYOR CARRYING IDLERS
DRAWING NUMBER	PAPER	SCALE	REV.				
BTS 011	A3	N.T.S.	A				SHEET 1 OF 1



NOTE :
 IDLERS SHALL COMPLY WITH SABS 1313/LATEST
 AND SALDANHA BULK TERMINAL SPECIFICATION
 SBH 39.07.04/LATEST.

AMENDMENTS

STORES MATERIAL SAP NO.
 138513

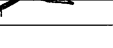
TITLE	NAME	SIGNATURE	DATE
DRAWN	S.BOLITSHI		26/07/2012
CHECKED	P.SWART		26/07/2012
APPROVED	N.STRYDOM		26/07/2012
PR.ENG / PR.TECH			DATE
SIGNATURE			
REG.NUMBER			



SALDANHA BULK TERMINAL

DRAWING TITLE: THROUGH, RETRACTABLE, TRAINING & RIGID SUSPENDED IDLER			
SUBTITLE: CONVEYOR CARRYING IDLERS			
DRAWING NUMBER	PAPER	SCALE	REV.
BTS 012	A3	N.T.S.	A

DIMENSIONS IN mm EXCEPT WHERE OTHERWISE INDICATED



FOR LIMITS ON UNTOLERANCED DIMENSIONS SEE BS 4500-PART 3(LATEST)

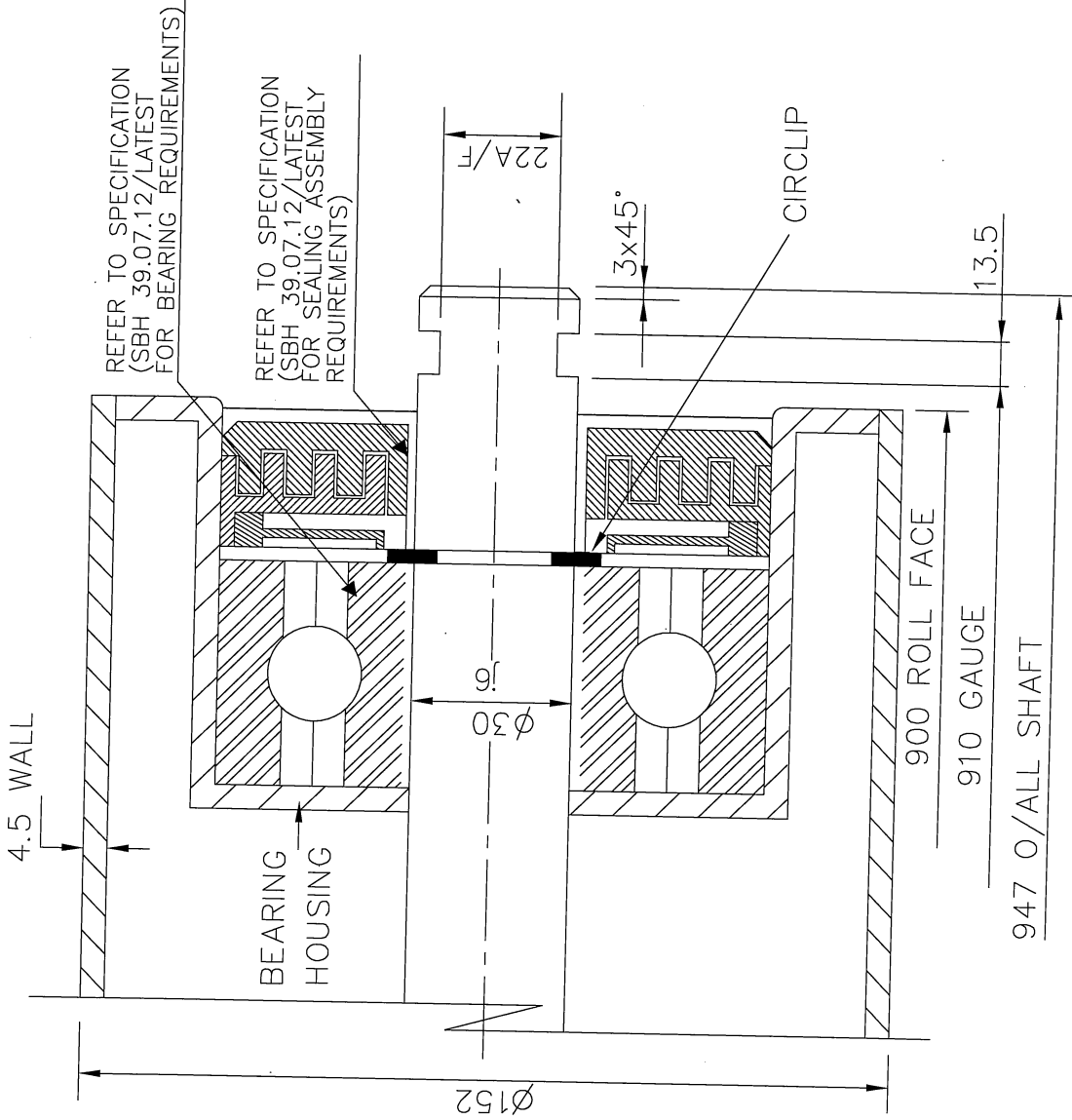

NOTE :
 IDLERS SHALL COMPLY WITH SABS 1313/LATEST
 AND SALDANHA BULK TERMINAL SPECIFICATION
 SBH 39.07.12/LATEST.

AMENDMENTS

STORES MATERIAL SAP NO.
138504

TITLE	NAME	SIGNATURE	DATE
DRAWN	S.BOLTSHI		25/07/2012
CHECKED	P.SWAART		25/07/2012
APPROVED	M.STRYDOM		25/07/2012
PR.ENG / PR.TECH			
NAME			DATE
SIGNATURE			
REG-NUMBER			



SALDANHA BULK TERMINAL

DRAWING TITLE:
SR4-FLAT RETURN IDLER-FIXED

SUBTITLE: CONVEYOR RETURN IDLER

DRAWING NUMBER
BTS 013

PAPER SCALE
A3

REV
N.T.S. A

SHEET 1 OF 1

DIMENSIONS IN mm EXCEPT WHERE OTHERWISE INDICATED



FOR LIMITS ON UNTOLERANCED DIMENSIONS SEE BS 4500:PART 3:(LATEST)

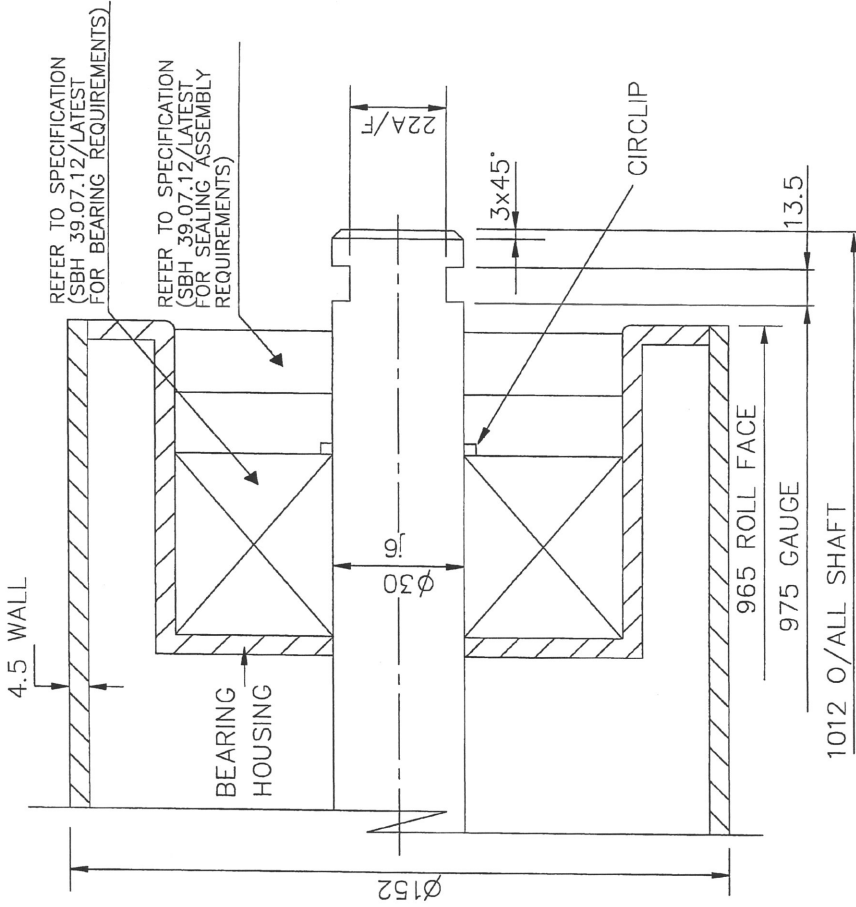

NOTE :
 IDLERS SHALL COMPLY WITH SABS 1313/LATEST
 AND SALDANHA BULK TERMINAL SPECIFICATION
 SBH 39.07.12/LATEST.

AMENDMENTS		STORES MATERIAL SAP NO. 138503		SALDANHA BULK TERMINAL	
TITLE DRAWN	NAME S.BOLITSKI	SIGNATURE	DATE 19/01/2012	DRAWING TITLE: SR4-V-RETURN IDLER-S30-1600BV-2ROLL	
CHECKED	P.SWART		19/01/2012	SUBTITLE: CONVEYOR RETURN IDLERS	
APPROVED	N.SIRYIDIN		19/01/2012	DRAWING NUMBER: 1600	
PR.ENG / PR.TECH			DATE	DRAWING SCALE: 1:1	
NAME				BTS 014	
SIGNATURE				A3 INT.S.A	
REGNUMBER				SHEET 1 OF 1	

DIMENSIONS IN mm EXCEPT WHERE OTHERWISE INDICATED

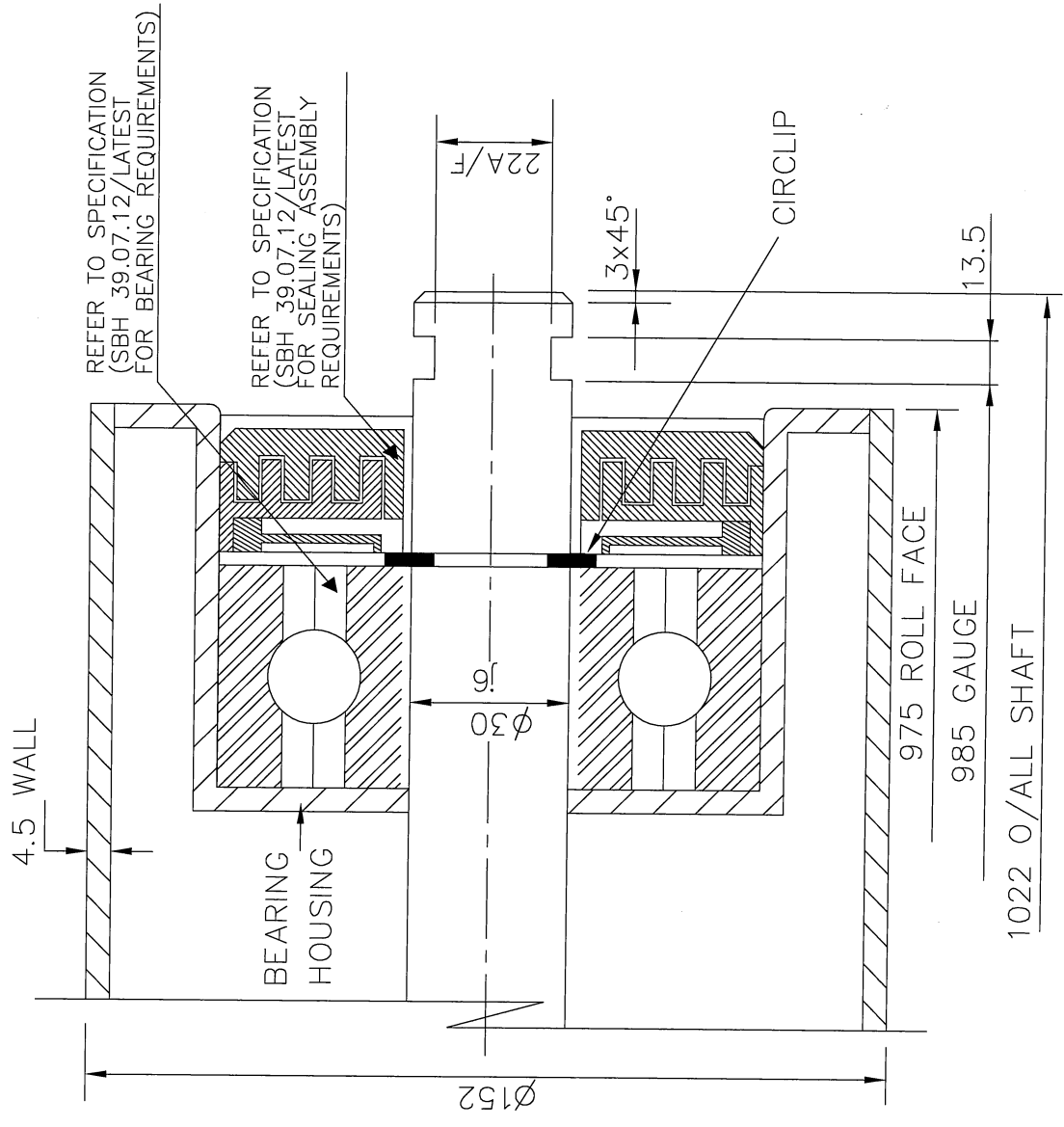

PROJECTION 

FOR LIMITS ON UNTOLERANCED DIMENSIONS SEE BS 4500:PART 3(LATEST)



NOTE :
 IDLERS SHALL COMPLY WITH SABS 1313/LATEST
 AND SALDANHA BULK TERMINAL SPECIFICATION
 SBH 39.07.12/LATEST.

TRANSNET

 SALDANHA BULK TERMINAL

TITLE	NAME	SIGNATURE	DATE
DRAWN	S. BOLTSHI		25/07/2012
CHECKED	P. SWART		25/07/2012
APPROVED	N. STRYDOM		25/07/2012
PR. ENG / PR. TECH			
NAME			DATE
SIGNATURE			
REG. NUMBER			

DRAWING TITLE: SR4-V-RETURN IDLER
 SUBTITLE: CONVEYOR RETURN IDLERS
 DRAWING NUMBER: SR4-V-RETURN IDLER
 PAPER SCALE: 1 REV.
 BTS 015 A3 N.T.S. A

STORES MATERIAL SAP NO.
 138502

AMENDMENTS

DIMENSIONS IN mm EXCEPT WHERE OTHERWISE INDICATED



FOR LIMITS ON UNTOLERANCED DIMENSIONS SEE BS 4500:PART 3(LATEST)

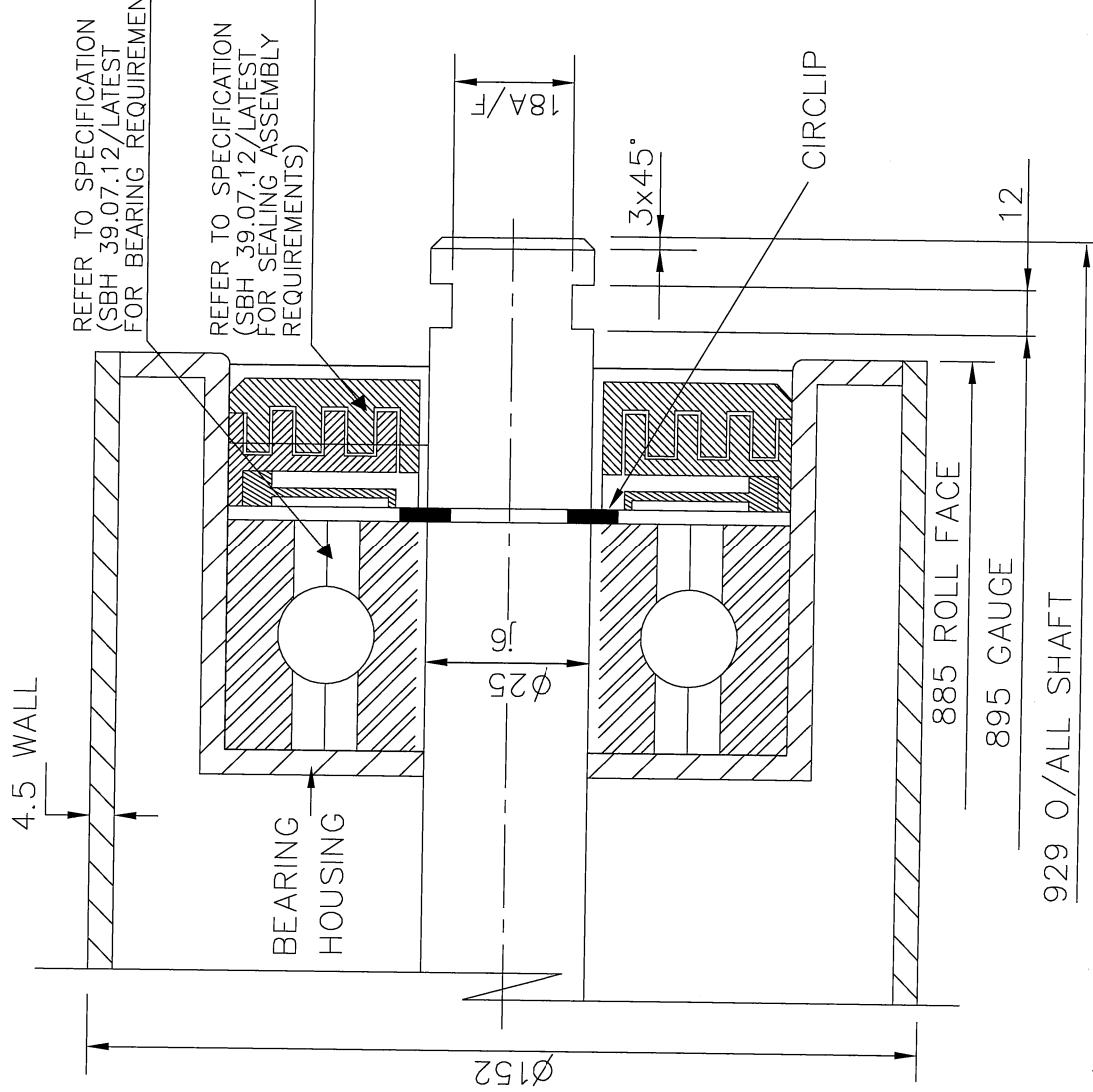

NOTE :

IDLERS SHALL COMPLY WITH SABS 1313/LATEST
AND SALDANHA BULK TERMINAL SPECIFICATION
SBH 39.07.12/LATEST.

AMENDMENTS

STORES MATERIAL SAP NO.
138510

TITLE	NAME	SIGNATURE	DATE
DRAWN	S.BOLITSHI		25/07/2012
CHECKED	P.SWART		25/07/2012
APPROVED	N.STRYDOM		25/07/2012
PR.ENG / PR.TECH			
NAME			DATE
SIGNATURE			
REG. NUMBER			

DRAWING TITLE:	
FLAT RETURN&V-RETURN IDLER	
SUBTITLE: CONVEYOR RETURN IDLERS	
DRAWING NUMBER	REV.
BTS 017	A3 N.T.S. A



SALDANHA BULK TERMINAL

SHEET 1 OF 1

DIMENSIONS IN mm EXCEPT WHERE OTHERWISE INDICATED

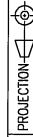

FOR LIMITS ON UNTOLERANCED DIMENSIONS SEE BS 4500:PART 3(LATEST)

NOTE :

IDLERS SHALL COMPLY WITH SABS 1313/LATEST AND SALDANHA BULK TERMINAL SPECIFICATION SBH 39.07.12/LATEST.

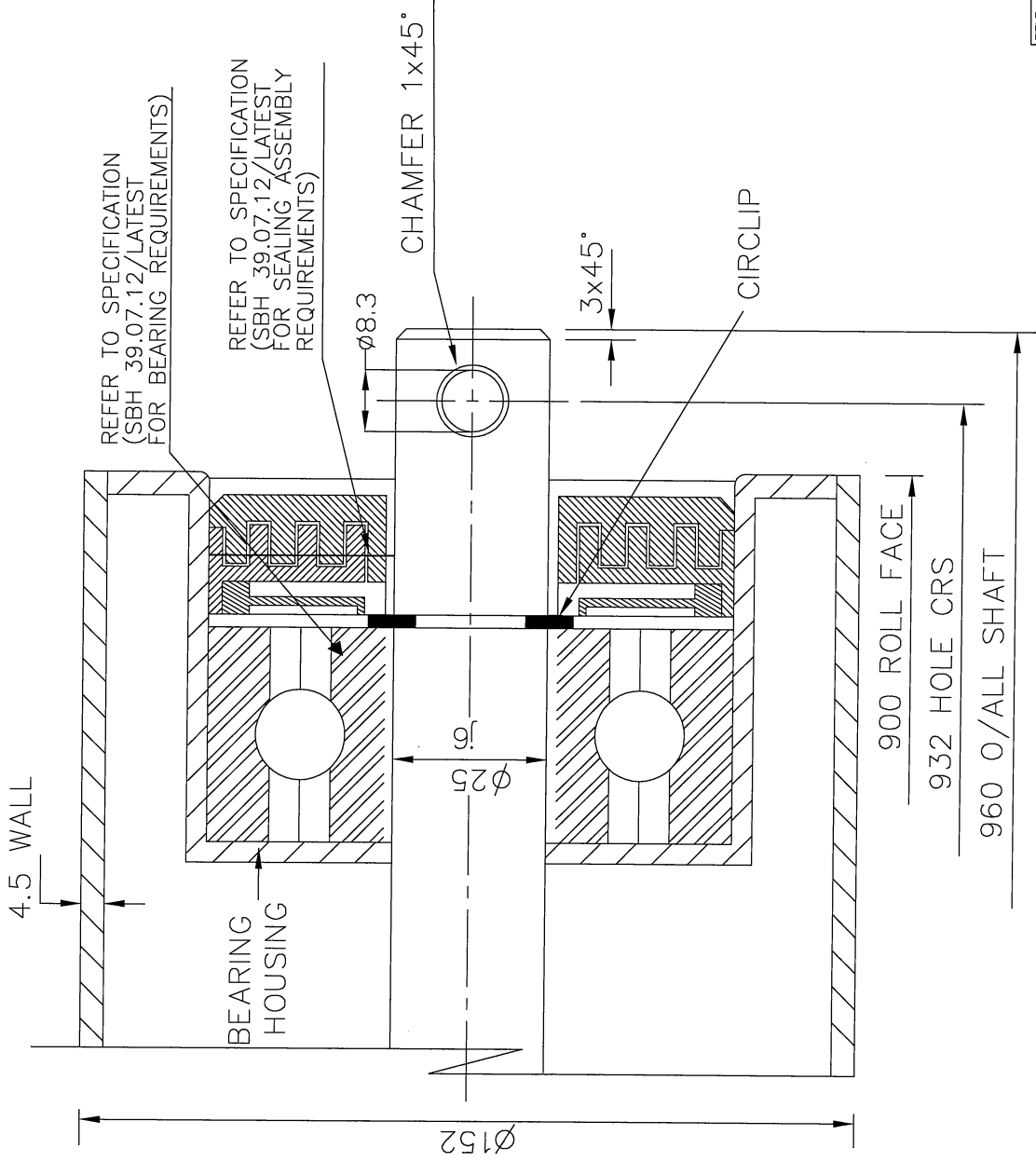

REV B- SHEET 2 ADDED FOR PLATE AND NUT LINKS

STORES MATERIAL SAP NO.
138506

AMENDMENTS

TITLE	NAME	SIGNATURE	DATE
DRAWN	S.BOLITSHI		25/07/2012
CHECKED	P.SWART		25/07/2012
APPROVED	N.STRYDOM		25/07/2012
PR.ENG / PR.TEC			
NAME			DATE
SIGNATURE			
REG. NUMBER			

DRAWING TITLE:	
GARLAND V-RETURN IDLER	
SUBTITLE: CONVEYOR RETURN IDLERS	
DRAWING NUMBER	PAPER SCALE
BTS 018	A3 N.T.S.

SALDANHA BULK TERMINAL	
DRAWING TITLE:	
GARLAND V-RETURN IDLER	
SUBTITLE: CONVEYOR RETURN IDLERS	
DRAWING NUMBER	PAPER SCALE
BTS 018	A3 N.T.S.

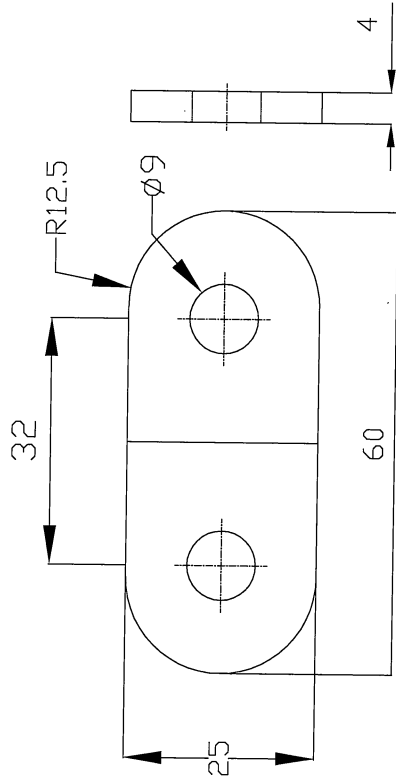

PLATE

MATERIAL: PLATE

SABS 1431 GRADE 350WA
HOT DIP GALVANISED

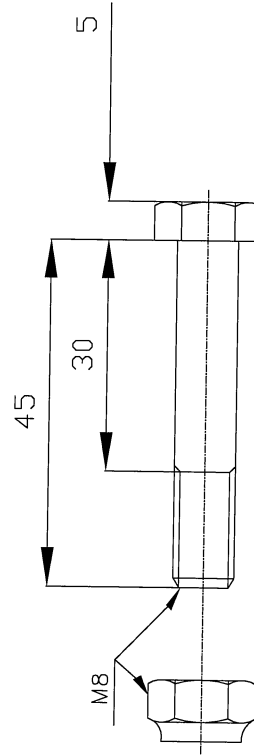

NUT

MATERIAL: NUT

STAINLESS STEEL

AMENDMENTS

REV B- SHEET 2 ADDED FOR PLATE AND NUT LINKS

STORES MATERIAL SAP NO.

138506

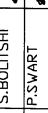
TITLE DRAWN	NAME S.BOLITSHI	SIGNATURE	DATE 25/07/2012
CHECKED	P.SWART		25/07/2012
APPROVED	INSTRIYDUM		25/07/2012
PR.ENG / PR.TECH			
NAME			DATE
SIGNATURE			
REG.NUMBER			



SALDANHA BULK TERMINAL

DRAWING TITLE:

GARLAND V-RETURN IDLER

SUBTITLE: CONVEYOR RETURN IDLERS

DRAWING NUMBER

PAPER SCALE

REV.

A3

1:1

A/B

SHEET 2 OF 2

DIMENSIONS IN mm EXCEPT WHERE OTHERWISE INDICATED

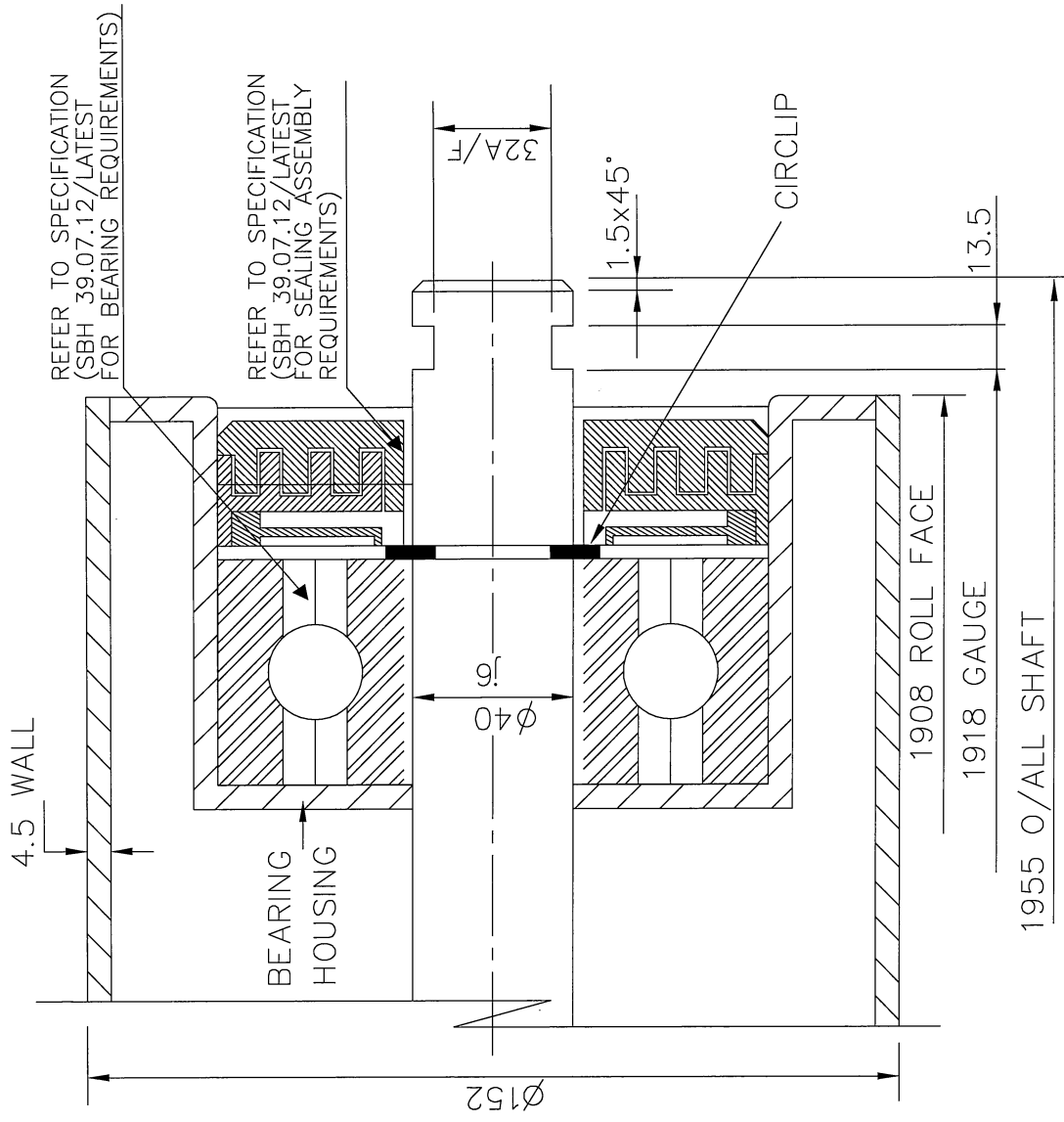

PROJECTION 

FOR LIMITS ON UNTOLERANCED DIMENSIONS SEE BS 4500:PART 3(LATEST)



NOTE :

IDLERS SHALL COMPLY WITH SABS 1313/LATEST AND SALDANHA BULK TERMINAL SPECIFICATION SBH 39.07.12/LATEST.

TITLE	NAME	SIGNATURE	DATE
DRAWN	S.BOLITSHI		25/07/2012
CHECKED	P.SWART		25/07/2012
APPROVED	N.STRYDOM		25/07/2012
PR.ENG / PR.TECH			
NAME			DATE
SIGNATURE			
REG. NUMBER			

TRANSHET
SALDANHA BULK TERMINAL

DRAWING TITLE:	BTS 029	A3	N.T.S.	A								SHEET 1 OF 1
SUBTITLE:												
DRAWING NUMBER												
PAPER SCALE												
REV.												
DRAWING NUMBER												
PAPER SCALE												
REV.												
DRAWING NUMBER												
PAPER SCALE												
REV.												
DRAWING NUMBER												
PAPER SCALE												
REV.												

STORES MATERIAL SAP NO.
115629

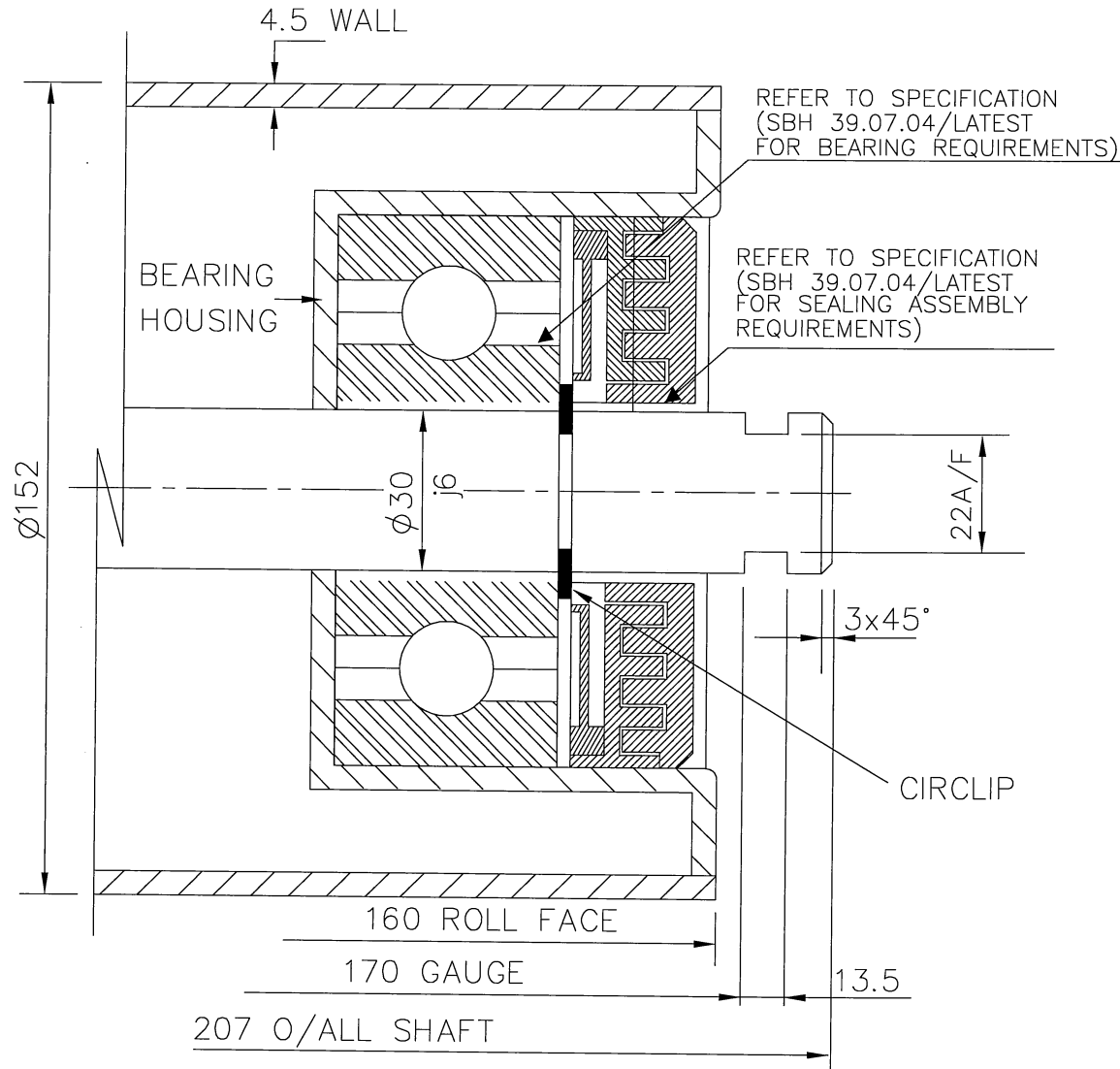

AMENDMENTS



NOTE :
 IDLERS SHALL COMPLY WITH SABS 1313/LATEST
 AND SALDANHA BULK TERMINAL SPECIFICATION
 SBH 39.07.04/LATEST.

AMENDMENTS	
------------	--

STORES MATERIAL SAP NO.
 134970

TITLE	NAME	SIGNATURE	DATE
DRAWN	S.BOLITSHI		26/07/2012
CHECKED	P.SWART		26/07/2012
APPROVED	N.STRYDOM		26/07/2012
PR.ENG / PR.TECH			DATE
NAME			
SIGNATURE			
REG.NUMBER			

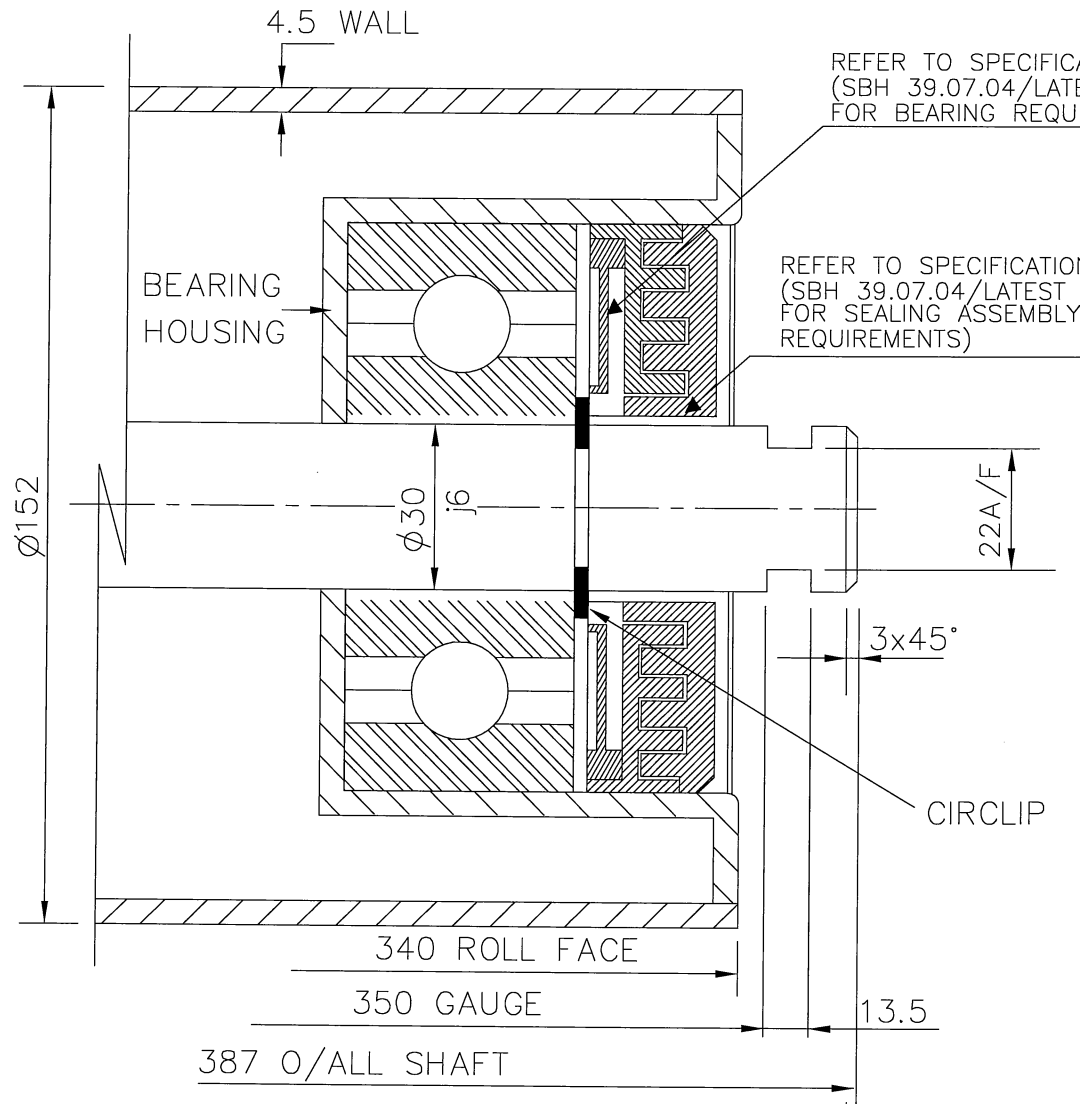

 SALDANHA BULK TERMINAL			
DRAWING TITLE: STEEL IMPACT CARRYING IDLER			
SUBTITLE: CONVEYOR 109			
DRAWING NUMBER	PAPER	SCALE	REV.
BTS 030	A3	N.T.S. A	
			SHEET 1 OF 1



NOTE :
 IDLERS SHALL COMPLY WITH SABS 1313/LATEST
 AND SALDANHA BULK TERMINAL SPECIFICATION
 SBH 39.07.04/LATEST.

AMENDMENTS

STORES MATERIAL SAP NO.
 136856

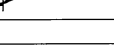
TITLE	NAME	SIGNATURE	DATE
DRAWN	S.BOLITSHI		26/07/2012
CHECKED	P.SWART		26/07/2012
APPROVED	N.STRYDOM		26/07/2012
PR.ENG / PR.TECH			
NAME			DATE
SIGNATURE			
REG.NUMBER			

 SALDANHA BULK TERMINAL			
DRAWING TITLE: STEEL IMPACT CARRYING IDLER			
SUBTITLE: TRAIN SIDE CONVEYORS			
DRAWING NUMBER	PAPER	SCALE	REV.
BTS 031	A3	N.T.S.	A
			SHEET 1 OF 1

NOTE :
 IDLERS SHALL COMPLY WITH SABS 1313/LATEST
 AND SALDANHA BULK TERMINAL SPECIFICATION
 SBH 39.07.12/LATEST.

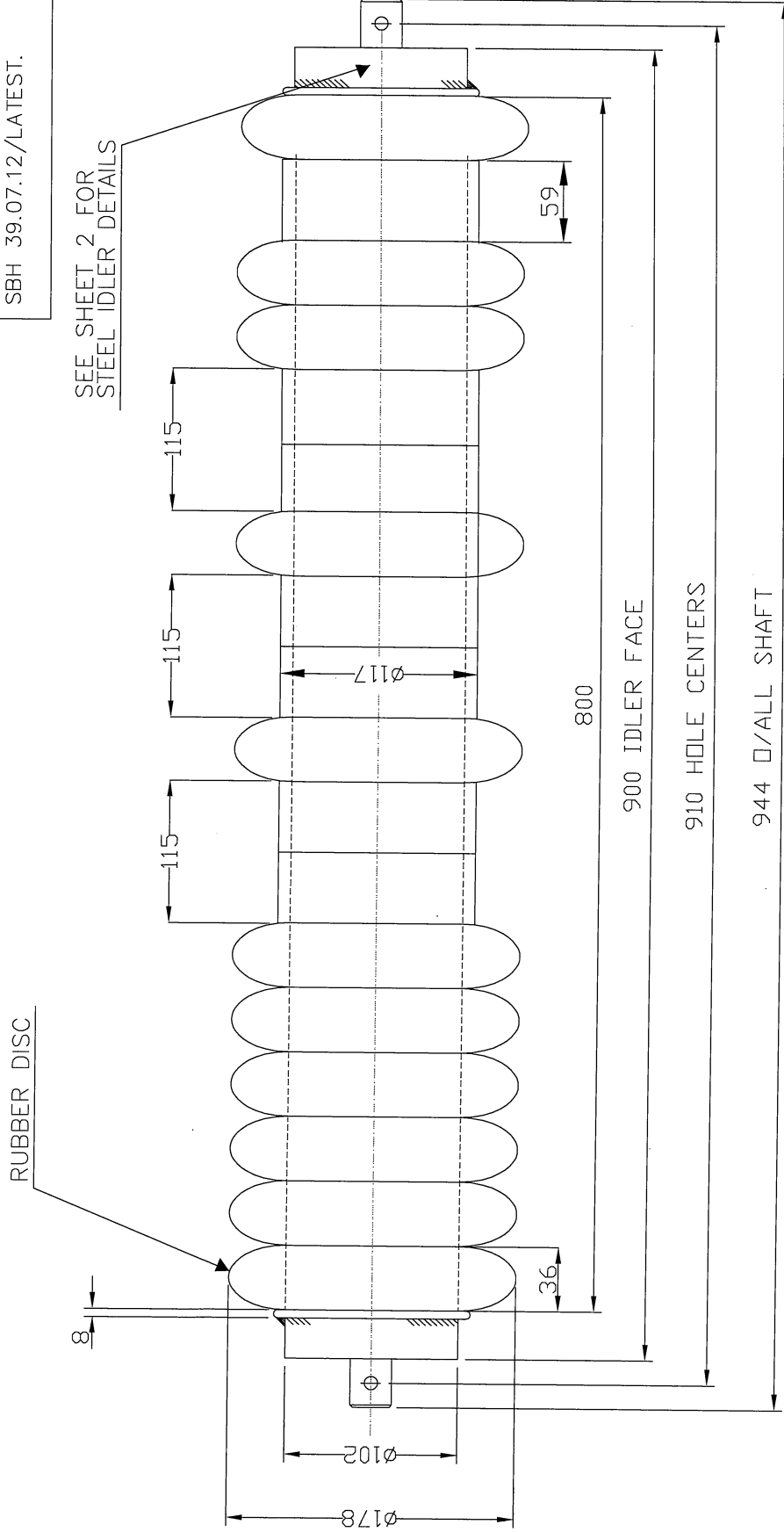

ISSUED FOR TENDERING PURPOSES - ONLY

AMENDMENTS

STORES MATERIAL SAP NO.
 134971

TITLE DRAWN	NAME S. BOLTSHI	SIGNATURE <i>[Signature]</i>	DATE 25/07/2012
CHECKED	P. SWART	<i>[Signature]</i>	25/07/2012
APPROVED	M. STRYDOM	<i>[Signature]</i>	25/07/2012
PR. ENG	PR. TECH		
NAME		DATE	
SIGNATURE			
REG. NUMBER			

TERMINET
 SALDANHA BULK TERMINAL

DRAWING TITLE:
 RUBBER V-RETURN IDLER

SUBTITLE:
 CONVEYOR RETURN IDLER

DRAWING NUMBER
 BITS 032

PAPER SCALE
 A3 N.T.S. A

REV

4.5 WALL

REFER TO SPECIFICATION (SBH 39.07.12/LATEST FOR BEARING REQUIREMENTS)

REFER TO SPECIFICATION (SBH 39.07.12/LATEST FOR SEALING ASSEMBLY REQUIREMENTS)

Ø25 NOM.

Ø102

Ø25

Ø8.5^{+0.1000}
-0.0000

3x45°

900 ROLL FACE

910 HOLE CENTRES

944 O/ALL SHAFT

NOTE :
IDLERS SHALL COMPLY WITH SABS 1313/LATEST
AND SALDANHA BULK TERMINAL SPECIFICATION
SBH 39.07.12/LATEST.

FOR ASSEMBLY SEE DRG. A3SBH2112

ISSUED FOR TENDERING PURPOSES - ONLY

TITLE DRAWN	NAME S. BOLITSHI	SIGNATURE	DATE 25/07/2012
CHECKED	P. SWART		25/07/2012
APPROVED	M. STRYDOM		25/07/2012
PR. ENG / PR. TECH			
NAME			DATE
SIGNATURE			
REG. NUMBER			

STORES MATERIAL SAP NO. 134971		SALDANHA BULK TERMINAL	
AMENDMENTS		DRAWING TITLE: STEEL IDLER DETAILS	
		SUBTITLE: CONVEYOR RETURN IDLER	
		DRAWING NUMBER	
		PAPER SCALE	
		REV	
		A3	
		N.T.S.	
		A	
		SHEET 2 OF 2	



NOTE :

IDLERS SHALL COMPLY WITH SABS 1313/LATEST AND SALDANHA BULK TERMINAL SPECIFICATION SBH 39.07.12/LATEST.

RUBBER DISC

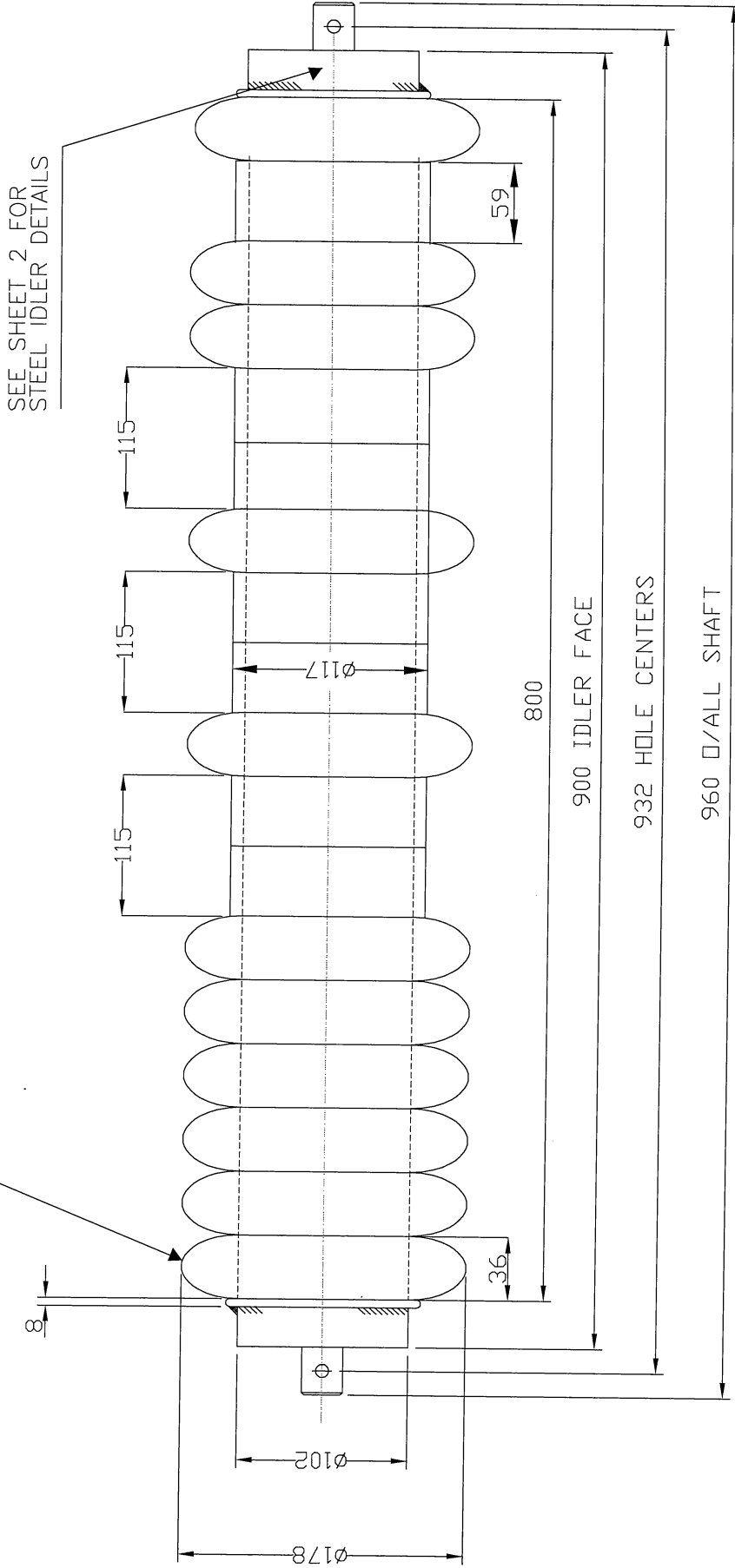



ISSUED FOR TENDERING PURPOSES - ONLY

AMENDMENTS

STORES MATERIAL SAP NO.

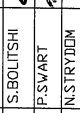
127584

TITLE	NAME	SIGNATURE	DATE
DRAWN	S. BOLITSHI		25/07/2012
CHECKED	P. SWART		25/07/2012
APPROVED	N. STRYDOM		25/07/2012
PR. ENG / PR. TECH			
NAME	DATE		
SIGNATURE			
REG. NUMBER			



SALDANHA BULK TERMINAL

DRAWING TITLE:

RUBBER V-RETURN IDLER-COMLETE

SUBTITLE: CONVEYOR RETURN IDLER

DRAWING NUMBER: PAPER SCALE: REV.

BTS 033 A3 N.T.S. A

DIMENSIONS IN mm EXCEPT WHERE OTHERWISE INDICATED



FOR LIMITS ON UNTOLERANCED DIMENSIONS SEE BS 4500:PART 3(LATEST)

REFER TO SPECIFICATION (SBH 39.07.12/LATEST FOR BEARING REQUIREMENTS)

REFER TO SPECIFICATION (SBH 39.07.12/LATEST FOR SEALING ASSEMBLY REQUIREMENTS)

NOTE :
IDLERS SHALL COMPLY WITH SABS 1313/LATEST
AND SALDANHA BULK TERMINAL SPECIFICATION
SBH 39.07.12/LATEST.

FOR ASSEMBLY SEE DRG. A3SBH2112

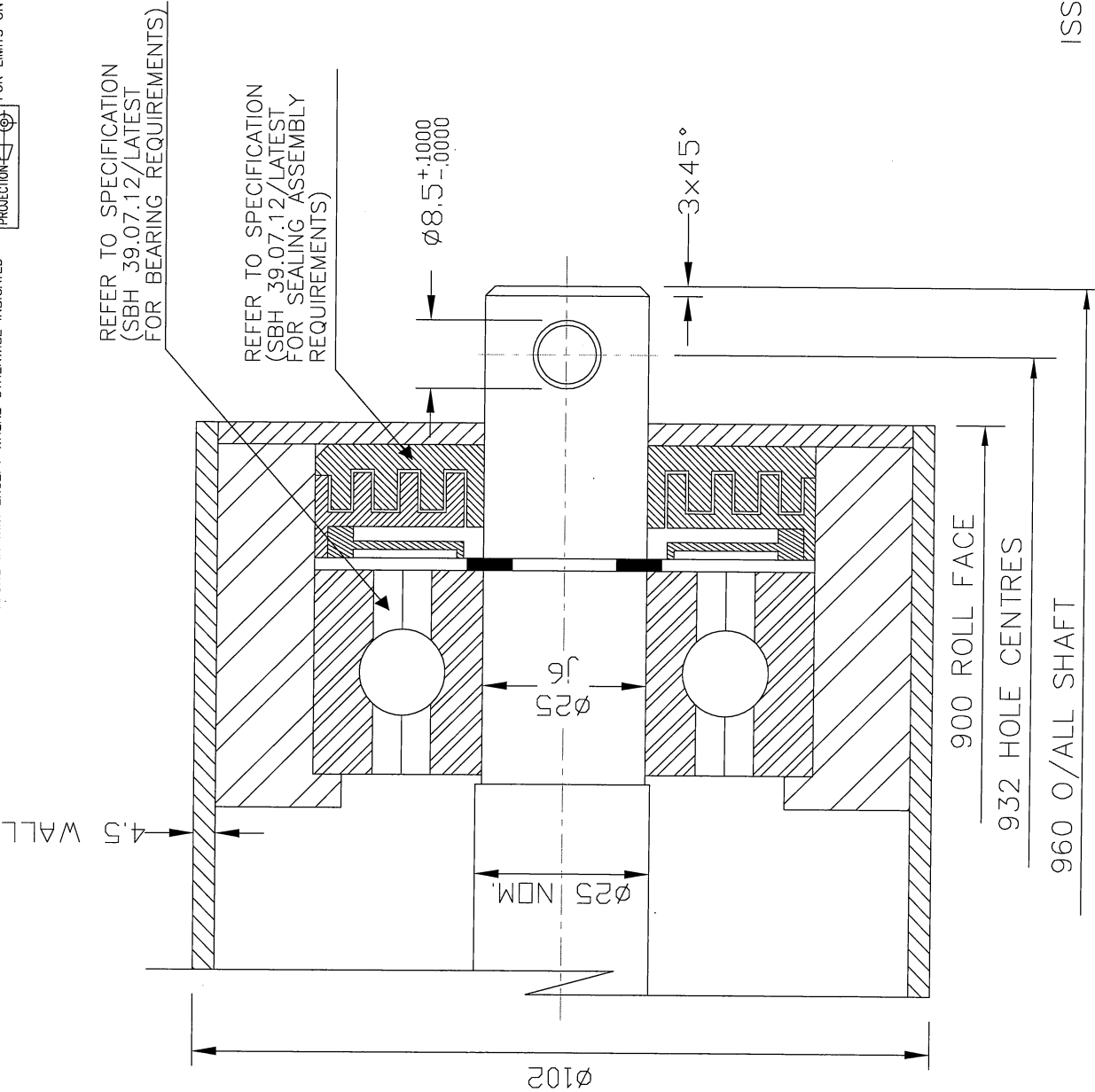

ISSUED FOR TENDER PURPOSES ONLY

TITLE	NAME	SIGNATURE	DATE
DRAWN	S.BOLITSHI	[Signature]	25/07/2012
CHECKED	P.SWART	[Signature]	25/07/2012
APPROVED	N.STRYDOM	[Signature]	25/07/2012
PR.ENG / PR.TECH			
NAME			DATE
SIGNATURE			
REG. NUMBER			

STORES MATERIAL SAP NO. 127584	
AMENDMENTS	

TRANSMET		SALDANHA BULK TERMINAL	
DRAWING NUMBER		DRAWING TITLE:	
PAPER SCALE		STEEL IDLER DETAILS	
REV.		SUBTITLE: CONVEYOR RETURN IDLER	
BTS 033		DRAWING NUMBER	
A3		N.T.S./A	
SHEET 2 OF 2			

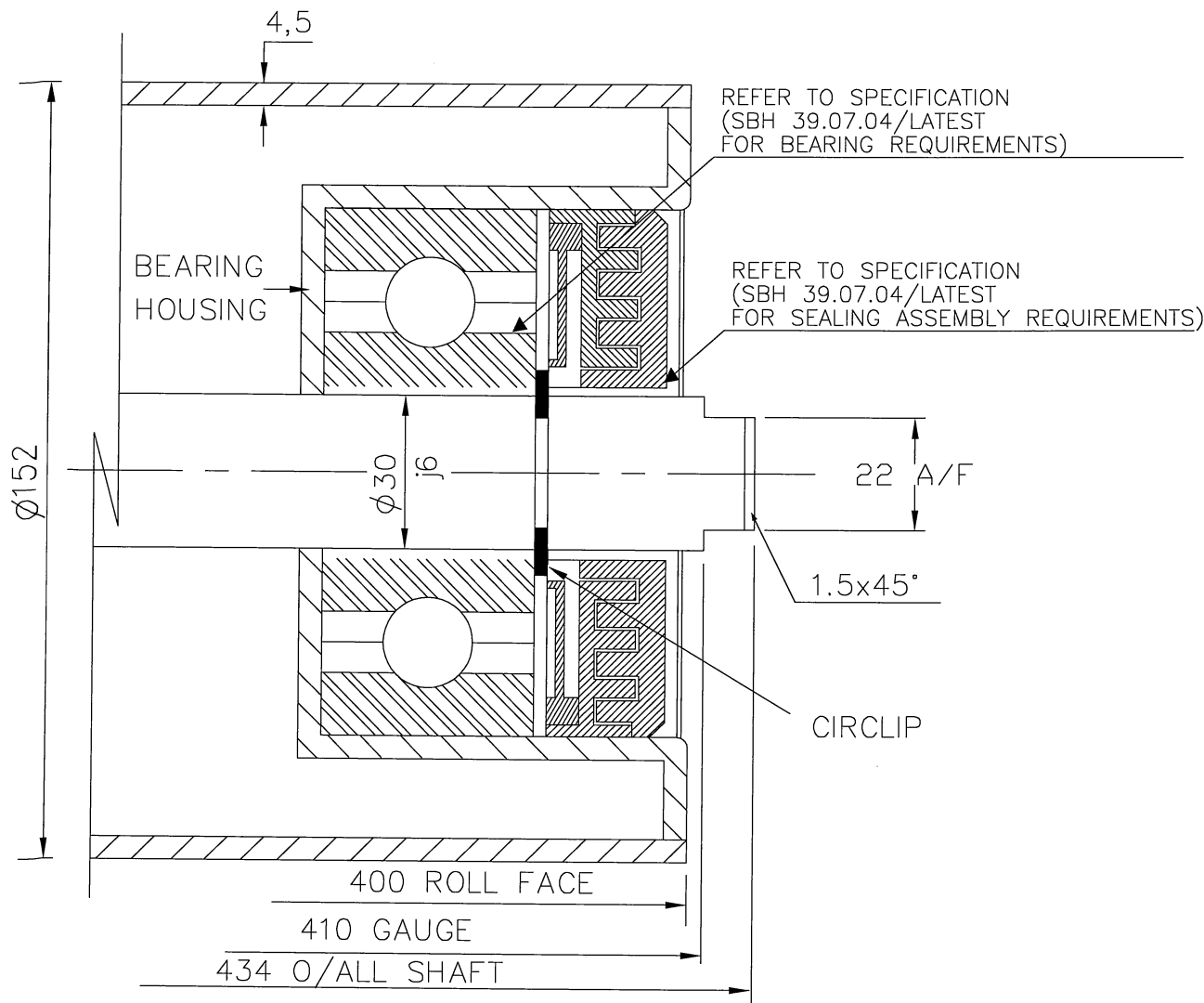



NOTE :

IDLERS SHALL COMPLY WITH SABS 1313/LATEST AND SALDANHA BULK TERMINAL SPECIFICATION SBH 39.07.04/LATEST.

IDLER MUST BE BALANCED AS IT IS TO BE USED ON A CONVEYOR SCALE

ISSUED FOR TENDERING PURPOSES - ONLY

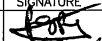
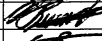
STORES MATERIAL SAP NO.
134110

TITLE	NAME	SIGNATURE	DATE
DRAWN	S.BOLITSHI		26/07/2012
CHECKED	P.SWART		26/07/2012
APPROVED	N.STRYDOM		26/07/2012
PR.ENG / PR.TECH			
NAME			DATE
SIGNATURE			
REG.NUMBER			

 SALDANHA BULK TERMINAL			
DRAWING TITLE: SCALE IDLER 400mm FACE			
SUBTITLE: CONVEYOR SCALE			
DRAWING NUMBER	PAPER	SCALE	REV.
BTS 036	A3	N.T.S. A	
			SHEET 1 OF 1

AMENDMENTS

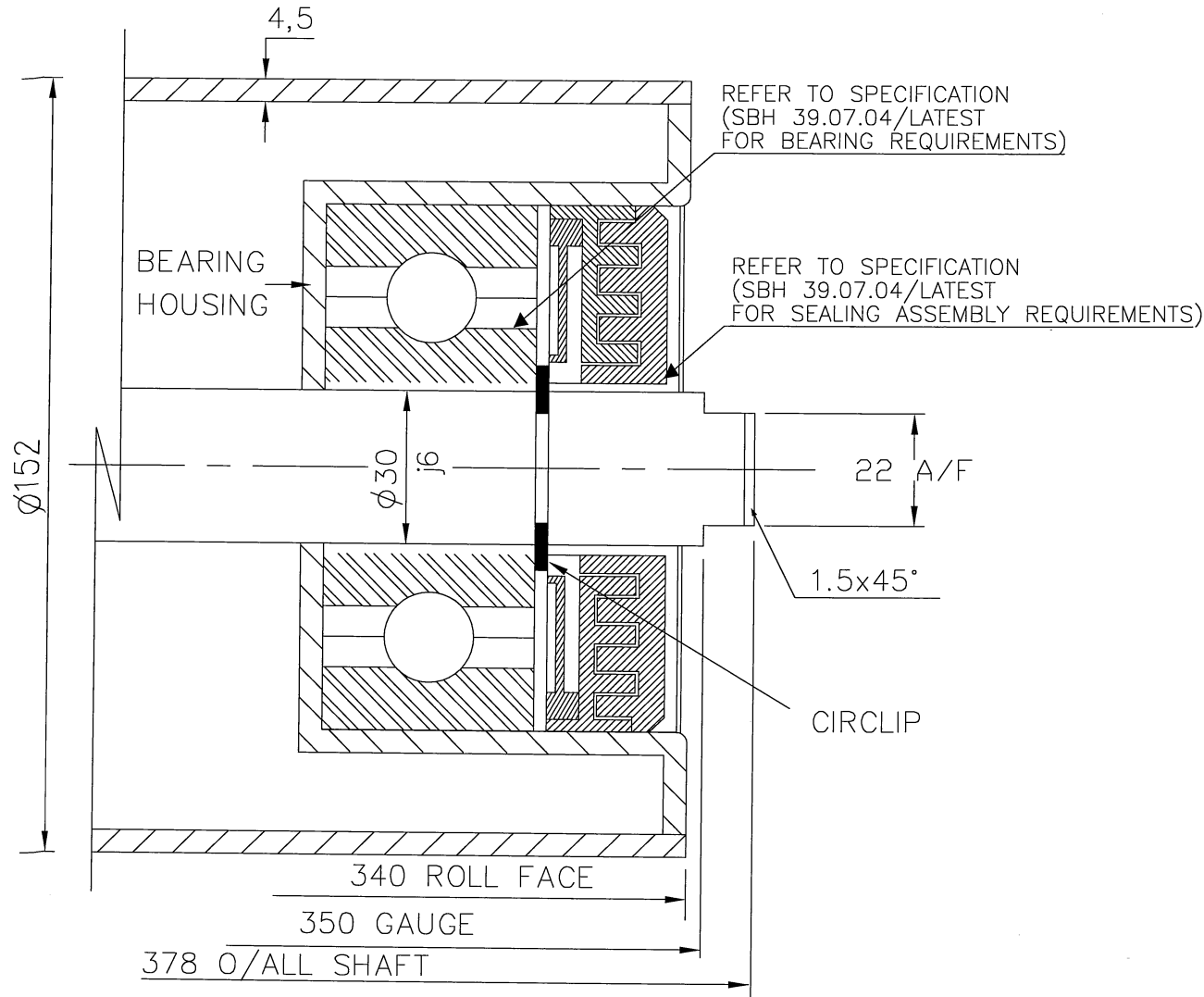





NOTE :
 IDLERS SHALL COMPLY WITH SABS 1313/LATEST
 AND SALDANHA BULK TERMINAL SPECIFICATION
 SBH 39.07.04/LATEST.
 IDLER MUST BE BALANCED AS IT IS TO BE
 USED ON A CONVEYOR SCALE

ISSUED FOR TENDERING PURPOSES - ONLY

AMENDMENTS	
------------	--

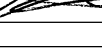
STORES MATERIAL SAP NO.
 134123

TITLE	NAME	SIGNATURE	DATE
DRAWN	S.BOLITSHI		26/07/2012
CHECKED	P.SWART		26/07/2012
APPROVED	N.STRYDOM		26/07/2012
PR.ENG / PR.TECH			
NAME			DATE
SIGNATURE			
REG.NUMBER			

			
SALDANHA BULK TERMINAL			
DRAWING TITLE: SCALE IDLER 340mm FACE			
SUBTITLE: CONVEYOR SCALE			
DRAWING NUMBER	PAPER	SCALE	REV.
BTS 037	A3	N.T.S. A	
			SHEET 1 OF 1

DIMENSIONS IN mm EXCEPT WHERE OTHERWISE INDICATED

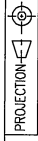

FOR LIMITS ON UNTOLERANCED DIMENSIONS SEE BS 4500-PART 3(LATEST)

NOTE :

IDLERS SHALL COMPLY WITH SABS 1313/LATEST AND SALDANHA BULK TERMINAL SPECIFICATION SBH 39.07.04/LATEST.

RUBBER DISC

SEE SHEET 2 FOR STEEL IDLER DETAILS

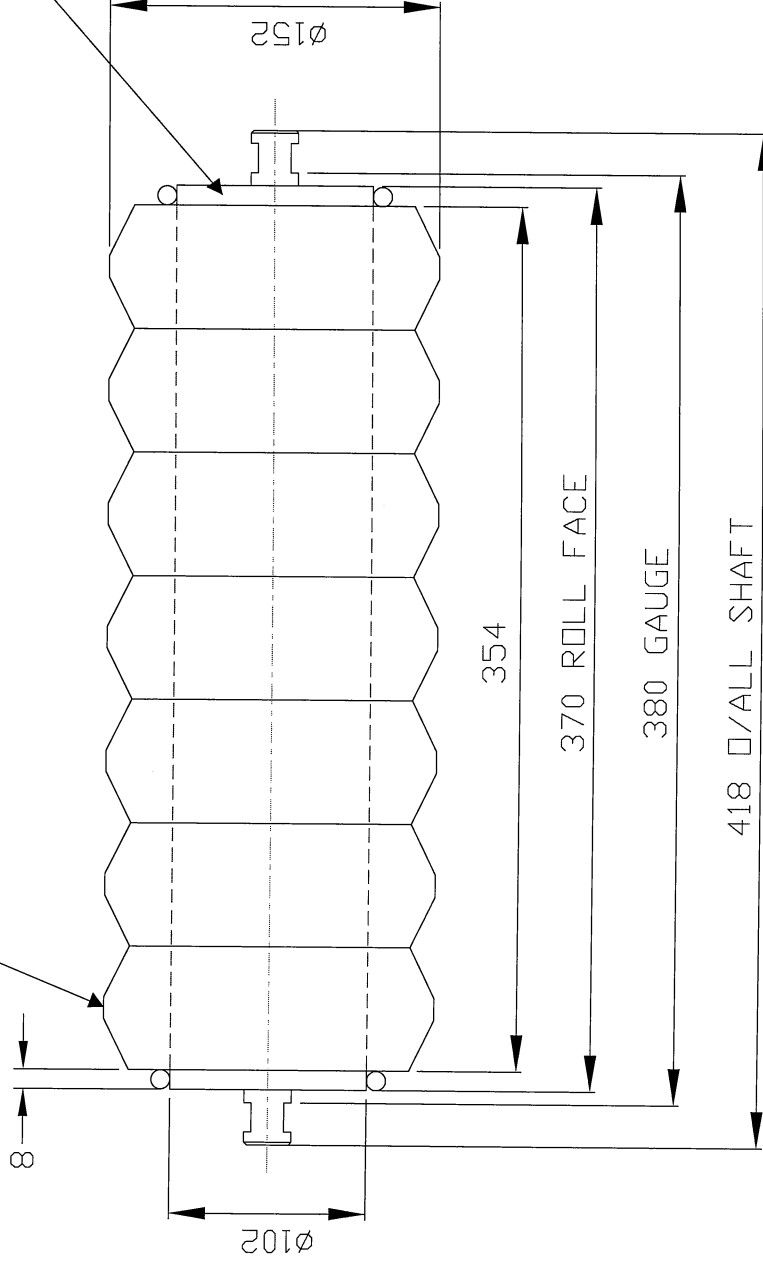

ISSUED FOR TENDERING PURPOSES - ONLY

AMENDMENTS
-/8
DRAWING
TEMPLATE
UPDATED,
SHEET 2
ADDED

STORES MATERIAL SAP NO.

131072

TITLE	NAME	SIGNATURE	DATE
DRAWN	S. BOLTISHI		25/07/2012
CHECKED	P. SWART		25/07/2012
APPROVED	N. STRYDOM		25/07/2012
PR. ENG /	PR. TECH		
NAME			DATE
SIGNATURE			
REG. NUMBER			



SALDANHA BULK TERMINAL

DRAWING TITLE:

RUBBER CARRYING IDLER 370 IDLER FACE

SUBTITLE: METSD S/R INCLINE CONVEYDR

DRAWING NUMBER

PAPER SCALE

REV

BTS 038

A3

N.T.S.

B

SHEET 1 DF 2

DIMENSIONS IN mm EXCEPT WHERE OTHERWISE INDICATED



FOR LIMITS ON UNTOLERANCED DIMENSIONS SEE BS 4500:PART 3(LATEST)

NOTE :
 IDLERS SHALL COMPLY WITH SABS 1313/LATEST
 AND SALDANHA BULK TERMINAL SPECIFICATION
 SBH 39.07.04/LATEST.

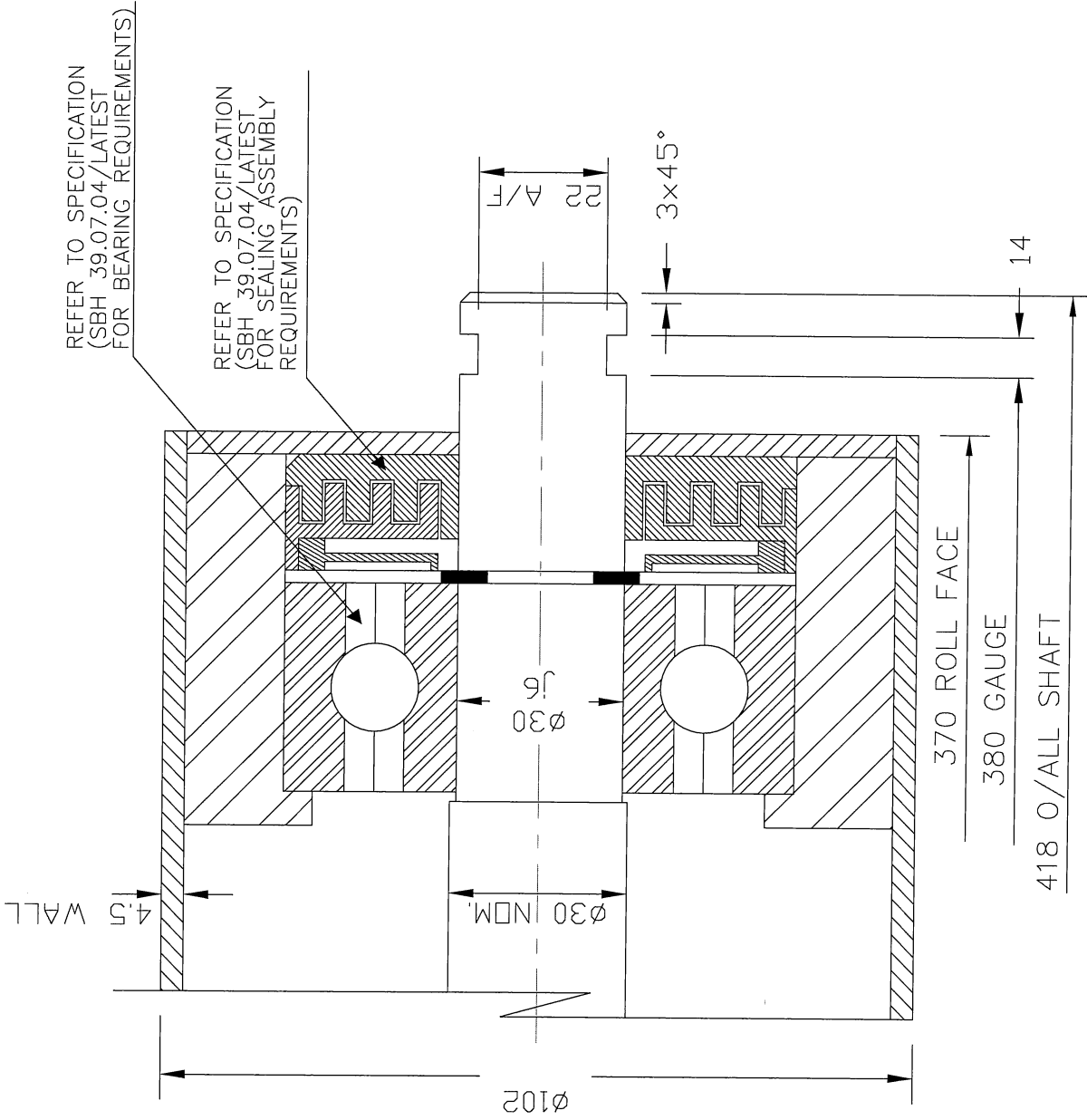

AMENDMENTS

-/B
 DRAWING
 TEMPLATE
 UPDATED,
 SHEET 2
 ADDED

STORES MATERIAL SAP NO.
 131072

TITLE	NAME	SIGNATURE	DATE
DRAWN	S. BOUITSHI	<i>[Signature]</i>	25/07/2012
CHECKED	P. SWART	<i>[Signature]</i>	25/07/2012
APPROVED	N. STRYDOM	<i>[Signature]</i>	25/07/2012
PR. ENG / PR. TECH			
NAME			DATE
SIGNATURE			
REG. NUMBER			

DRAWING TITLE:	
SUBTITLE: METSD S/R INCLINE CONVEYOR	STEEL IDLER DETAILS
DRAWING NUMBER	PAPER SCALE
BTS 038	REV.
A3	N.T.S. <i>[Initials]</i>

TRANSNET
 SALDANHA BULK TERMINAL

DIMENSIONS IN mm EXCEPT WHERE OTHERWISE INDICATED

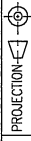

FOR LIMITS ON UNTOLERANCED DIMENSIONS SEE BS 4500-PART 3(LATEST)

NOTE :

IDLERS SHALL COMPLY WITH SABS 1313/LATEST AND SALDANHA BULK TERMINAL SPECIFICATION SBH 39.07.12/LATEST.

RUBBER DISC

SEE SHEET 2 FOR STEEL IDLER DETAILS

SYMMETRICAL ABOUT CENTRE LINE

105

52

105

156

8

Ø152

Ø105

885 IDLER FACE

895 GAUGE

933 O/ALL SHAFT

ISSUED FOR TENDERING PURPOSES - ONLY

STORES MATERIAL SAP NO.

131070

AMENDMENTS

TITLE	NAME	SIGNATURE	DATE
DRAWN	S.BOUTTSHI		25/07/2012
CHECKED	P.SWART		25/07/2012
APPROVED	N.STRYDOM		25/07/2012
PR.ENG / PR.TECH			
NAME			DATE
SIGNATURE			
REG. NUMBER			

TRANSNET
SALDANHA BULK TERMINAL

DRAWING TITLE:	
RUBBER RETURN IDLER	
SUBTITLE: CONVEYOR RETURN IDLER	
DRAWING NUMBER	REV.
BTS 039	A3 N.T.S. A

SHEET 1 OF 2

DIMENSIONS IN mm EXCEPT WHERE OTHERWISE INDICATED

PROJECTION

FOR LIMITS ON UNTOLERANCED DIMENSIONS SEE BS 4500:PART 3(LATEST)

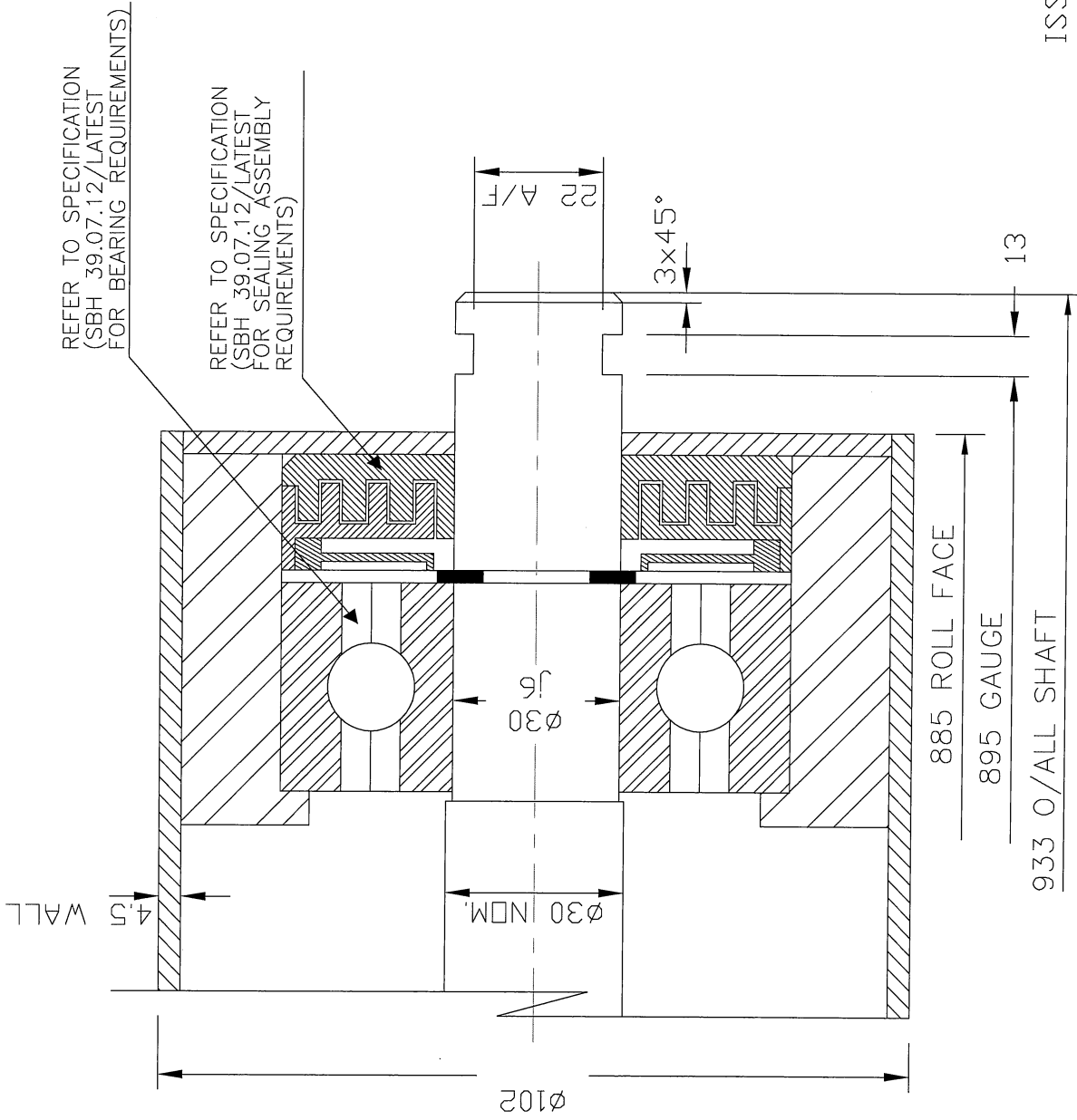

NOTE :
 IDLERS SHALL COMPLY WITH SABS 1313/LATEST
 AND SALDANHA BULK TERMINAL SPECIFICATION
 SBH 39.07.12/LATEST.

ISSUED FOR TENDERING PURPOSES - ONLY

TITLE	NAME	SIGNATURE	DATE
DRAWN	S.BOLITSHI	<i>[Signature]</i>	25/07/2012
CHECKED	P.SWART	<i>[Signature]</i>	25/07/2012
APPROVED	N.STRYDOM	<i>[Signature]</i>	25/07/2012
PR.ENG / PR.TECH			
NAME			DATE
SIGNATURE			
REG. NUMBER			

DRAWING TITLE:		STEEL IDLER DETAILS
SUBTITLE:	CONVEYOR RETURN IDLER	
DRAWING NUMBER	PAPER SCALE	REV.
BTS 039	A3	N.T.S. A

STORES MATERIAL SAP NO.
 131070

AMENDMENTS

DRAWING TEMPLATE

UPDATED

1/8

SHEET 2 ADDED

TRANSNET

SALDANHA BULK TERMINAL

DRAWING TITLE: STEEL IDLER DETAILS

SUBTITLE: CONVEYOR RETURN IDLER

DRAWING NUMBER: A3

PAPER SCALE: N.T.S. | A

REV. SHEET 2 OF 2

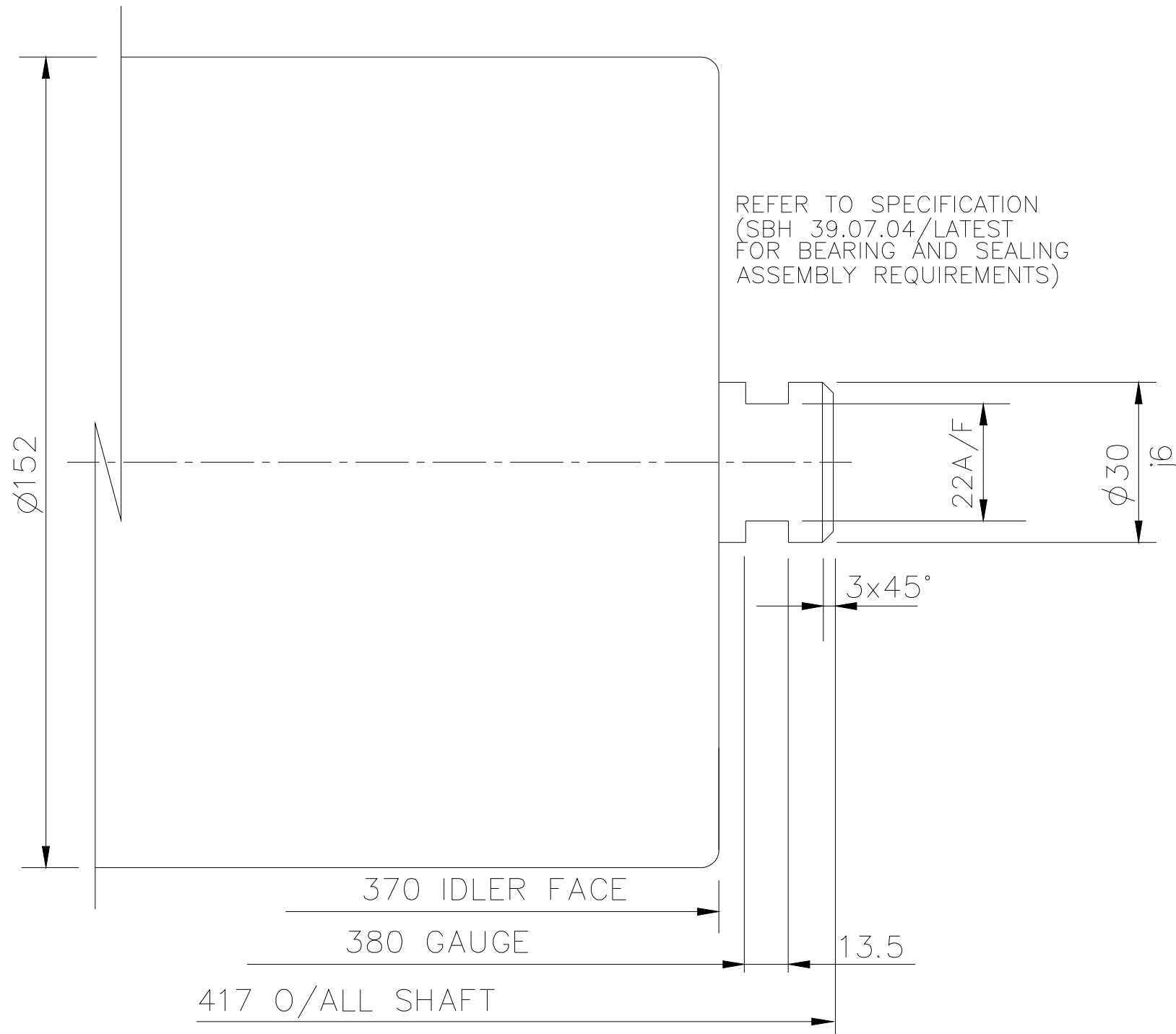

REFER TO SPECIFICATION
(SBH 39.07.04/LATEST
FOR BEARING AND SEALING
ASSEMBLY REQUIREMENTS)

NOTE :

IDLERS SHALL COMPLY WITH SABS 1313/LATEST
AND SALDANHA BULK TERMINAL SPECIFICATION
SBH 39.07.04/LATEST.

ISSUED FOR TENDERING PURPOSES - ONLY

AMENDMENTS

STORES MATERIAL SAP NO.

124772

TITLE	NAME	SIGNATURE	DATE
DRAWN	S.BOLITSHI		08/06/2012
CHECKED	P.SWART		08/06/2012
APPROVED	N.STRYDOM		08/06/2012
PR.ENG / PR.TECH			
NAME		DATE	
SIGNATURE			
REG.NUMBER			



SALDANHA BULK TERMINAL

DRAWING TITLE:
IDLER, HDPE , 370mm IDLER FACE
SUBTITLE: CONVEYOR 114

DRAWING NUMBER	PAPER	SCALE	REV.						
BTS 040	A3	N.T.S.	A						

DIMENSIONS IN mm EXCEPT WHERE OTHERWISE INDICATED

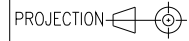

FOR LIMITS ON UNTOLERANCED DIMENSIONS SEE BS 4500:PART 3(LATEST)

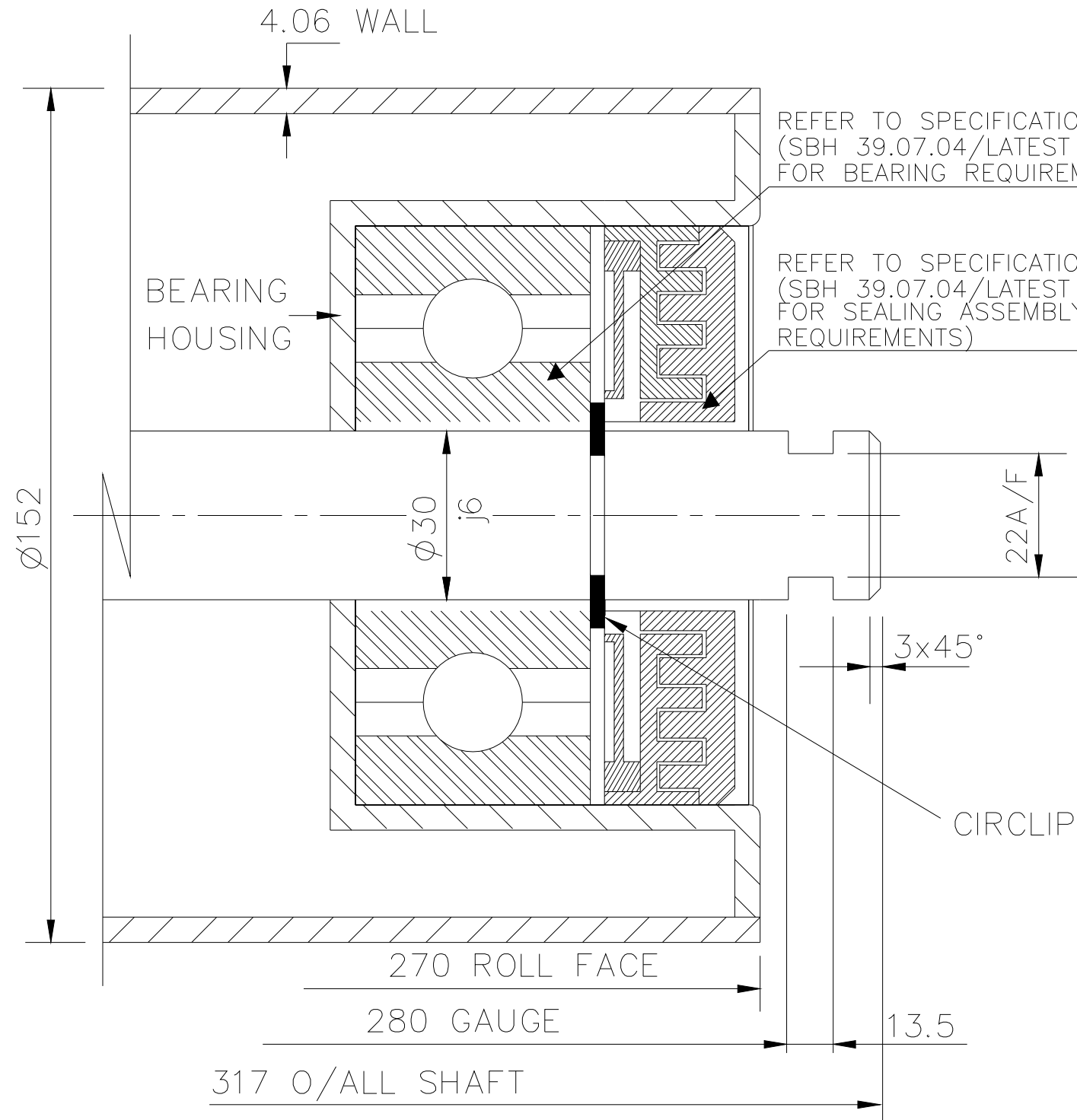

REFER TO SPECIFICATION (SBH 39.07.04/LATEST FOR BEARING REQUIREMENTS)

REFER TO SPECIFICATION (SBH 39.07.04/LATEST FOR SEALING ASSEMBLY REQUIREMENTS)

NOTE :
IDLERS SHALL COMPLY WITH SABS 1313/LATEST AND SALDANHA BULK TERMINAL SPECIFICATION SBH 39.07.04/LATEST.

AMENDMENTS	
------------	--

STORES MATERIAL SAP NO.
N/S

TITLE	NAME	SIGNATURE	DATE
DRAWN	S.BOLITSHI		15/10/2015
CHECKED	I.MOKOPANELE		15/10/2015
APPROVED	J.KESTER		15/10/2015
PR.ENG / PR.TECH			
NAME			DATE
SIGNATURE			
REG.NUMBER			



SALDANHA BULK TERMINAL

DRAWING TITLE:			
CARRYING IDLER - DIA 152 270 FACE SERIES 30			
SUBTITLE:			
CONVEYOR CV314			
DRAWING NUMBER	PAPER	SCALE	REV.
BTS 073	A3	N.T.S.	A
			SHEET 1 OF 1

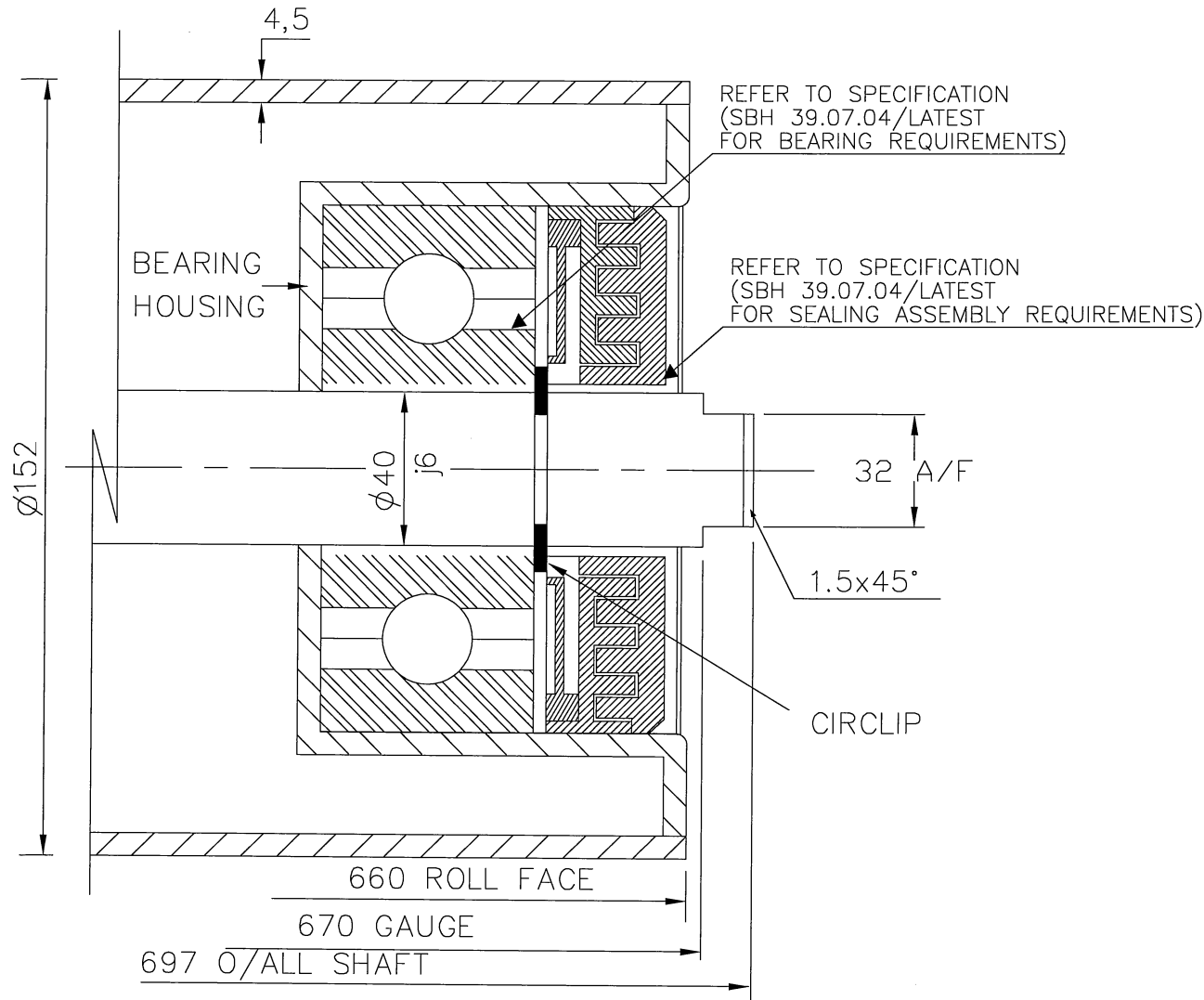



NOTE :

IDLERS SHALL COMPLY WITH SABS 1313/LATEST AND SALDANHA BULK TERMINAL SPECIFICATION SBH 39.07.04/LATEST.

IDLER MUST BE BALANCED AS IT IS TO BE USED ON A CONVEYOR SCALE

ISSUED FOR TENDERING PURPOSES - ONLY

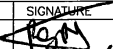
STORES MATERIAL SAP NO.
141201

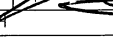
TITLE	NAME	SIGNATURE	DATE
DRAWN	S.BOLITSHI		26/07/2012
CHECKED	P.SWART		26/07/2012
APPROVED	N.STRYDOM		26/07/2012
PR.ENG / PR.TECH			
NAME			DATE
SIGNATURE			
REG.NUMBER			

 SALDANHA BULK TERMINAL			
DRAWING TITLE: BOOM CONVEYOR SCALE ROLLER			
SUBTITLE: STACKER RECLAIMER 4			
DRAWING NUMBER	PAPER	SCALE	REV.
SBHS 5040	A3	N.T.S.	A B
			SHEET 1 OF 1

AMENDMENTS	-/B	DRAWING TEMPLATE	UPDATED
------------	-----	------------------	---------



MASTER AGREEMENT

entered into by and between

TRANSNET SOC LTD

and

.....

**FOR THE PROVISION OF SERVICE TO SUPPLY AND DELIVER CONVEYOR
CARRYING IDLERS AND RETURN-IDLER ASSEMBLIES FOR A ONCE OFF
PERIOD**

Agreement Number

Commencement Date

Expiry Date

TABLE OF CONTENTS

1	INTRODUCTION.....	3
2	DEFINITIONS	3
3	INTERPRETATION	6
4	NATURE AND SCOPE	7
5	AUTHORITY OF PARTIES	7
6	DURATION/TERM AND CANCELLATION.....	7
7	RISK MANAGEMENT	8
8	TRANSNET'S OBLIGATIONS	8
9	GENERAL OBLIGATIONS OF THE SUPPLIER.....	8
10	SERVICE PROVIDER'S PERSONNEL	11
11	SUBCONTRACTING.....	11
12	PAYMENT TO SUB-CONTRACTORS	12
13	B-BBEE AND SOCIO-ECONOMIC OBLIGATIONS	12
14	LOCAL CONTENT OBLIGATIONS.....	13
17	PENALTIES	ERROR! BOOKMARK NOT DEFINED.
18	FEES AND EXPENSES RELATING TO SERVICES	17
19	INVOICES AND PAYMENT	17
20	PRICE ADJUSTMENTS.....	18
21	WARRANTIES APPLICABLE TO GOODS.....	19
22	WARRANTIES APPLICABLE TO SERVICES	19
23	THIRD PARTY INDEMNITY	21
24	INSPECTION APPLICABLE TO GOODS	21
25	DEFECTIVE GOODS	22
26	TOTAL OR PARTIAL FAILURE TO PERFORM.....	23
27	NON CONFORMANCE OF SERVICES PROCURED.....	23
28	RIGHTS ON CANCELLATION.....	23
29	BREACH AND TERMINATION.....	24
30	CESSIONS AND ASSIGNMENTS AS PER NT INSTRUCTION NOTE 08 OF 2022/2023.....	25
31	FORCE MAJEURE.....	25
32	PROTECTION OF PERSONAL INFORMATION.....	25
33	CONFIDENTIALITY	27
34	INSURANCES	S29
35	LIMITATION OF LIABILITY.....	30
36	INTELLECTUAL PROPERTY RIGHTS	30
37	NON-WAIVER	32
38	PARTIAL INVALIDITY	33
39	DISPUTE RESOLUTION	33
40	ADDRESSES FOR NOTICES	33
41	WHOLE AND ONLY AGREEMENT.....	34
42	AMENDMENT AND CHANGE CONTROL	34
43	GENERAL.....	34
44	DATABASE OF RESTRICTED SUPPLIER.....	35

SCHEDULE 1 – WORK ORDER / SCHEDULE OF REQUIREMENTS

1 INTRODUCTION

This Agreement is entered into by and between:

Transnet SOC Ltd [Registration Number 1990/000900/30] whose registered address is
....., Republic of South Africa [**Transnet**]

and

..... [Registration Number] whose registered address is
..... [**the Supplier**].

NOW THEREFORE, IT IS AGREED:

- 1.1 Transnet hereby appoints the Supplier to provide, and Transnet undertakes to accept the provision of Services provided for herein, as formally agreed between the Parties and in accordance with the Schedule of Requirements / Work Orders issued as a schedule to this Agreement; and
- 1.2 the Supplier hereby undertakes to provide the Services provided for herein, as formally agreed between the Parties and in accordance with the Schedule of Requirements issued as a schedule to this Agreement.

2 DEFINITIONS

Where the following words or phrases are used in this Agreement, such words or phrases shall have the meaning assigned thereto in this clause, except where the context clearly requires otherwise:

- 2.1 **AFSA** means the Arbitration Foundation of South Africa;
- 2.2 **Agreement** means this Agreement and its associated schedules and/or annexures and/or appendices, and/or schedules, including the Schedule of Requirements/Work Orders, the technical specifications for the Services and such special conditions as shall apply to this Agreement, together with the General Tender Conditions and any additional provisions in the associated bid documents tendered by the Supplier [as agreed, in writing, between the Parties], which collectively and exclusively govern the provision of Services and provision of ancillary Services by the Supplier to Transnet;
- 2.3 **Assignment** refers to the transfer of rights and obligations in a contract from an assigner to an assignee.
- 2.4 **Background Intellectual Property** means all Intellectual Property introduced and required by either Party to give effect to their obligations under this Agreement owned in whole or in part by or licensed to either Party or their affiliates prior to the Commencement Date or developed after the Commencement Date otherwise pursuant to this Agreement;
- 2.5 **Business Day(s)** means Mondays to Fridays between 07:30 and 16:00, excluding public holidays as proclaimed in South Africa;
- 2.6 **Cession** refers to the transfer of only the rights a service provider has in terms of a contract from it to a third party.

- 2.7 **Commencement Date** means, notwithstanding the signature date of this Agreement;
- 2.8 **Confidential Information** means any information or other data, whether in written, oral, graphic or in any other form such as in documents, papers, memoranda, correspondence, notebooks, reports, drawings, diagrams, discs, articles, samples, test results, prototypes, designs, plans, formulae, patents, or inventor's certificates, which a Party discloses or provides to the other Party [intentionally or unintentionally, or as a result of one Party permitting the representative of the other Party to visit any of its premises], or which otherwise becomes known to a Party, and which is not in the public domain and includes, without limiting the generality of the term:
- a) information relating to methods of operation, data and plans of the disclosing Party;
 - b) the contents of this Agreement;
 - c) private and personal details of employees or clients of the disclosing Party or any other person where an onus rests on the disclosing Party to maintain the confidentiality of such information;
 - d) any information disclosed by either Party and which is clearly marked as being confidential or secret;
 - e) information relating to the strategic objectives and planning of the disclosing Party relating to its existing and planned future business activities;
 - f) information relating to the past, present and future research and development of the disclosing Party;
 - g) information relating to the business activities, business relationships, products, services, customers, clients and Subcontractors of the disclosing Party where an onus rests on the disclosing Party to maintain the confidentiality of such information;
 - h) information contained in the software and associated material and documentation belonging to the disclosing Party;
 - i) technical and scientific information, Know-How and trade secrets of a disclosing Party including inventions, applications and processes;
 - j) Copyright works;
 - k) commercial, financial and marketing information;
 - l) data concerning architecture, demonstrations, tools and techniques, processes, machinery and equipment of the disclosing Party;
 - m) plans, designs, concepts, drawings, functional and technical requirements and specifications of the disclosing Party;
 - n) information concerning faults or defects in Goods, equipment, hardware or software or the incidence of such faults or defects; and
 - o) information concerning the charges, fees and/or costs of the disclosing Party or its authorised Subcontractors, or their methods, practices or service performance levels actually achieved;
- 2.9 **Copyright** means the right in expressions, procedures, methods of operations or mathematical concepts, computer program codes, compilations of data or other material, literary works, musical works, artistic works, sound recordings, broadcasts, program carrying signals, published editions,

photographic works, or cinematographic works of the copyright owner to do or to authorise the doing of certain acts specified in respect of the different categories of works;

- 2.10 **Data** means all data, databases, documents, information, graphics, text or other material in an electronic or tangible medium which the Parties to this Agreement generate, collect, process, store or transmit in relation to their business;
- 2.11 **Designs** mean registered Designs and/or Design applications and will include the monopoly right granted for the protection of an independently created industrial design including designs dictated essentially by technical or functional considerations as well as topographies of integrated circuits and integrated circuits;
- 2.12 **Expiry Date** means Once off ;
- 2.13 **Foreground Intellectual Property** means all Intellectual Property developed by either Party pursuant to this Agreement;
- 2.14 **Goods** means provision of service to supply and deliver conveyor carrying idlers and return idler assembled on a once off period, the material / products specified in the Schedule of Requirements appended as Schedule 1 hereto;
- 2.15 **ICC Incoterms** means the the latest version of commercial trade terms as published by the International Chamber of Commerce, Paris [ICC], which are otherwise referred to as purchase terms and which define precisely the responsibilities, costs and risks of the buyer [**Transnet**] and the seller [**the Supplier**]. Incoterms are only applicable to contracts involving the import or export of Goods from one country to another and for the purpose of this Agreement, if applicable, shall mean the designated Incoterm as stipulated in Schedule 1 hereto. Further details of the Incoterm [purchase terms] for this Agreement, if applicable, can be viewed at the International Business Training website - <http://www.i-b-t.net/incoterms.html>;
- 2.16 **Imported content** means that portion of the bid price represented by the cost of components, parts or materials which have been or are still to be imported (whether by the supplier or its subcontractors) and which costs are inclusive of the costs abroad (this includes labour or intellectual property costs), plus freight and other direct importation costs, such as landing costs, dock duties, import duty, sales duty or other similar tax or duty at the South African port of entry;
- 2.17 **Intellectual Property** means Patents, Designs, Know-How, Copyright and Trade Marks and all rights having equivalent or similar effect which may exist anywhere in the world and includes all future additions and improvements to the Intellectual Property;
- 2.18 **Know-How** means all Confidential Information of whatever nature relating to the Intellectual Property and its exploitation as well as all other Confidential Information generally relating to Transnet's field of technology, including technical information, processing or manufacturing techniques, Designs, specifications, formulae, systems, processes, information concerning materials and marketing and business information in general;
- 2.19 **Local content** means that portion of the bid price which is not included in the imported content, provided that local manufacture does take place;
- 2.20 **Parties** mean the Parties to this Agreement together with their subsidiaries, divisions, business units, successors-in-title and assigns;
- 2.21 **Party** means either one of these Parties;

- 2.22 **Patents** mean registered Patents and Patent applications, once the latter have proceeded to grant, and includes a right granted for any inventions, products or processes in all fields of technology;
- 2.23 **Permitted Purpose** means any activity or process to be undertaken or supervised by a Staff member of one Party during the term of this Agreement, for which purpose authorised disclosure of the other Party's Confidential Information or Intellectual Property is a prerequisite in order to enable such activity or process to be accomplished;
- 2.24 **Price(s)** means the agreed Price(s) for the Services to be purchased from the Supplier by Transnet, as detailed in the Schedule of Requirements, issued in accordance with this Agreement, as amended by mutual agreement between the Parties and in accordance with the terms and conditions in this Agreement from time to time;
- 2.25 **Purchase Order(s)** means official orders issued by an operating division of Transnet to the Supplier for the supply of Goods or Services;
- 2.26 **Service Level Agreement** or **SLA** means the processes, deliverables, key performance indicators and performance standards relating to the Services to be provided by the Supplier;
- 2.27 **Staff** means any partner, employee, agent, consultant, independent associate or contractor, Subcontractor and the staff of such Subcontractor, or other authorised representative of either Party;
- 2.28 **Schedule of Requirements** means Schedule 1 hereto;
- 2.29 **Subcontract** means any contract or agreement or proposed contract or agreement between the Supplier and any third party whereby that third party agrees to provide to the Supplier the Goods or related Services or any part thereof or material used in the manufacture of the Goods or any part thereof;
- 2.30 **Subcontractor** means the third party with whom the Supplier enters into a Subcontract;
- 2.31 **Tax Invoice** means the document as required by Section 20 of the VAT Act, as may be amended from time to time;
- 2.32 **Trade Marks** mean registered Trade Marks and Trade Mark applications and include any sign or logo, or combination of signs and/or logos capable of distinguishing the goods or services of one undertaking from those of another undertaking;
- 2.33 **VAT** means Value-Added Tax chargeable in terms of the VAT Act, 89 of 1991, as may be amended from time to time; and
- 2.34 **VAT Act** means the Value Added Tax Act, No 89 of 1991, as may be amended from time to time.

3 INTERPRETATION

- 3.1 Clause headings in this Agreement are included for ease of reference only and do not form part of this Agreement for the purposes of interpretation or for any other purpose. No provision shall be construed against or interpreted to the disadvantage of either Party hereto by reason of such Party having or being deemed to have structured or drafted such provision.
- 3.2 Any term, word or phrase used in this Agreement, other than those defined under the clause heading "*Definitions*" shall be given its plain English meaning, and those terms, words, acronyms, and phrases used in this Agreement will be interpreted in accordance with the generally accepted meanings accorded thereto.

- 3.3 A reference to the singular incorporates a reference to the plural and *vice versa*.
- 3.4 A reference to natural persons incorporates a reference to legal persons and *vice versa*.
- 3.5 A reference to a particular gender incorporates a reference to the other gender.

4 NATURE AND SCOPE

- 4.1 This Agreement is an agreement under the terms and conditions of which the Supplier will arrange for the supply/provision to Transnet of the Services which meet the requirements and specifications of Transnet, the delivery of which is controlled by means of Purchase Orders to be issued by Transnet and executed by the Supplier in accordance with this Agreement.
- 4.2 Such Purchase Orders and deliveries to Transnet shall be agreed between the Parties from time to time, subject to the terms of the Schedule of Requirements/Work Order.
- 4.3 Each properly executed Purchase Order forms an inseparable part of this Agreement as if it were fully incorporated into the body of this Agreement.
- 4.4 During the period of this Agreement, both Parties can make written suggestions for amendments to the Schedule of Requirements/Work Orders in accordance with procedures set out in clause 392 [*Amendment and Change Control*]. A Party will advise the other Party within 14 [fourteen] Business Days, or such other period as mutually agreed, whether the amendment is acceptable.
- 4.5 Insofar as any term, provision or condition in the Schedule of Requirements/Work Order conflicts with a like term, provision or condition in this Agreement and/or a Purchase Order, the term or provision or condition in this Master Agreement shall prevail, unless such term or provision or condition in this Master Agreement has been specifically revoked or amended by mutual written agreement between the Parties.
- 4.6 Time will be of the essence and the Supplier will perform its obligations under this Agreement in accordance with the timeframe(s) [if any] set out in the relevant schedule, save that the Supplier will not be liable under this clause if it is unable to meet such obligation within the time required as a direct result of any act or omission by Transnet and it has used its best endeavours to advise Transnet of such act or omission. In the event of such delay, any time deadlines detailed in the relevant schedule shall be extended by a period equal to the period of that delay.

5 AUTHORITY OF PARTIES

- 5.1 Nothing in this Agreement will constitute or be deemed to constitute a partnership between the Parties, or constitute or be deemed to constitute the Parties as agents or employees of one another for any purpose or in any form whatsoever.
- 5.2 Neither Party shall be entitled to, or have the power or authority to:
 - a) enter into an agreement in the name of the other; or
 - b) give any warranty, representation or undertaking on the other's behalf; or
 - c) create any liability against the other or bind the other's credit in any way or for any purpose whatsoever.

6 DURATION/TERM AND CANCELLATION

- 6.1 Notwithstanding the date of signature hereof, the Commencement Date if this Agreement is and the duration shall be for a [.....] year period, expiring on, unless:

- a) this Agreement is terminated by either Party in accordance with the provisions incorporated herein or in any schedules or annexures appended hereto, or otherwise in accordance with law or equity; or
 - b) this Agreement is extended at Transnet's option for a further period to be agreed by the Parties.
- 6.2 Notwithstanding clause 269 [*Breach and Termination*], either Party may cancel this Agreement without cause by giving 30 [thirty] calendar days prior written notice thereof to the other Party, provided that in such instance, this Agreement will nevertheless be applicable in respect of all Purchase Orders which have been placed prior to the date of such cancellation.

7 RISK MANAGEMENT

- 7.1 Where Transnet determines appropriate, within 2 weeks from the date of contract signature, the Parties are to meet to prepare and maintain a contract Risk Register. The Risk Register shall include a description of the risks and a description of the actions which are to be taken to avoid or reduce these risks which both Parties shall jointly determine.
- 7.2 Contract progress meetings shall be held monthly, or unless otherwise agreed between the Parties in writing. The purposes of these progress meetings shall be to capture the number of late deliverables against agreed milestones, actual costs against payment plans, performance issues or concerns, contract requirements not achieved, the status of previous corrective actions and risk management. Minutes of meetings shall be maintained and signed off between the Parties throughout the contract period

8 TRANSNET'S OBLIGATIONS

- 8.1 Transnet undertakes to promptly comply with any reasonable request by the Supplier for information, including information concerning Transnet's operations and activities, that relates to the Services as may be necessary for the Supplier to provide the Goods/Services, but for no other purpose. However, Transnet's compliance with any request for information is subject to any internal security rules and requirements and subject to the observance by the Supplier of its confidentiality obligations under this Agreement.
- 8.2 The Supplier shall give Transnet reasonable notice of any information it requires.
- 8.3 Transnet agrees to provide the Supplier or its Personnel such access to and use of its facilities as is necessary to allow the Supplier to perform its obligations under this Agreement.

9 GENERAL OBLIGATIONS OF THE SUPPLIER

- 9.1 The Supplier shall:
- a) respond promptly to all complaints and enquiries from Transnet;
 - b) inform Transnet immediately of any dispute or complaint arising in relation to the storage or delivery of the Goods;
 - c) conduct its business in a professional manner which will reflect positively upon the Supplier and the Supplier's/Service Provider's products/services;

- d) keep full records clearly indicating all transactions concluded by the Supplier relating to the delivery of the Services and keep such records for at least 5 [five] years from the date of each such transaction;
- e) obtain, and at all times maintain in full force and effect, any and all licences, permits and the like required under applicable laws for the provision of the Services and ancillary Services and the conduct of the business and activities of the Supplier;
- f) observe and ensure compliance with all requirements and obligations as set out in the labour and related legislation of South Africa, including the Occupational Health and Safety Act, 85 of 1993, as may be amended from time to time;
- g) observe and ensure compliance with all requirements and objectives of the Transnet Supplier Integrity Pact as agreed to in response to the RFP. The general purpose of the Supplier Integrity Pact is to agree to avoid all forms of dishonesty, fraud and corruption by following a system that is fair, transparent and free from any undue influence prior to, during and subsequent to the currency of the procurement event leading to this Agreement and this Agreement itself;
- h) comply with all applicable environmental legislation and regulations, demonstrate sound environmental performance and have an environmental management policy which ensures that its products, including the Services or ancillary Services are procured, produced, packaged, delivered and are capable of being used and ultimately disposed of in a way that is environmentally appropriate; and
- i) ensure the validity of all renewable certifications, including but not limited to its B-BBEE Verification Certificate, throughout the entire term of this Agreement. Should the Supplier fail to present Transnet with such renewals as they become due, Transnet shall be entitled, in addition to any other rights and remedies that it may have in terms of the Agreement, to terminate this Agreement forthwith without any liability and without prejudice to any claims which Transnet may have for damages against the Supplier.

9.2 The Supplier acknowledges and agrees that it shall at all times:

- a) render the supply of the Services and ancillary Services (if applicable) and perform all its duties with honesty and integrity;
- b) communicate openly and honestly with Transnet regarding the supply and performance of the Services and demonstrate a commitment to effecting the supply and performing ancillary Services timeously, efficiently and at least to the required standards;
- c) endeavour to provide the highest possible standards of service and workmanship, with a reasonable degree of care and diligence;
- d) use its best endeavours and make every diligent effort to meet agreed deadlines;
- e) treat its own Staff, as well as all Transnet's Staff, with fairness and courtesy and respect for their human rights;
- f) practice and promote its own internal policies aimed at prohibiting and preventing unfair discrimination;

- g) treat all enquiries from Transnet in connection with the supply of the Services and/or ancillary Services with courtesy and respond to all enquiries promptly and efficiently. Where the Supplier is unable to comply with the provisions of this clause, the Supplier will advise Transnet of the delay and the reasons therefor and will keep Transnet informed of progress made regarding the enquiry;
 - h) when requested by Transnet, provide clear and accurate information regarding the Supplier's/Service Provider's own policies and procedures, excluding Know-How and other Confidential Information, except where a non-disclosure undertaking has been entered into between the Parties;
 - i) not allow a conflict of interest to develop between its own interests [or the interests of any of its other customers] and the interests of Transnet;
 - j) not accept or offer, nor allow, induce or promote the acceptance or offering of any gratuity, enticement, incentive or gift that could reasonably be regarded as bribery or an attempt to otherwise exert undue influence over the recipient;
 - k) not mislead Transnet or its officers, employees and stakeholders, whether by act or omission;
 - l) not otherwise act in an unethical manner or do anything which could reasonably be expected to damage or tarnish Transnet's reputation or business image;
 - m) immediately report to Transnet any unethical, fraudulent or otherwise unlawful conduct of which it becomes aware in connection with Transnet or the supply of Services or ancillary Services to Transnet;
 - n) ensure that at all times, during the currency of this Agreement, it complies with all obligations and commitments in terms of the provisions of the Income Tax Act, No 58 of 1962, the VAT Act or any other tax legislation relating to their liability for Income Tax, VAT, Pay as You Earn or any other tax. The Supplier shall further ensure Tax Clearance Compliance, for the duration of this Agreement;
 - o) not victimise, harass or discriminate against any employee of either Party to this Agreement or any applicant for employment with either Party to this Agreement due to their gender, race, disability, age, religious belief, sexual orientation or part-time status. This provision applies, but is not limited to employment, upgrading, work environment, demotion, transfer, recruitment, recruitment advertising, termination of employment, rates of pay or other forms of compensation and selection for training.
 - p) shall ensure that its employees, agents and Subcontractors will not breach any applicable discrimination legislation and any amendments and re-enactments thereof.
- 9.3 In compliance with the National Railway Safety Regulator Act, 16 of 2002, as may be amended from time to time, the Supplier shall ensure that the Services and ancillary Services, to be supplied to Transnet under the terms and conditions of this Agreement, comply fully with the Specifications as set forth in Schedule 1 hereto, and shall thereby adhere [as applicable] to railway safety requirements and/or regulations. Permission for the engagement of a Subcontractor by the Supplier, as applicable, shall be subject to a review of the capability of the proposed Subcontractor to comply with the specified railway safety requirements and/or regulations. The Supplier and/or its

Subcontractor shall grant Transnet access, during the term of this Agreement, to review any safety-related activities, including the coordination of such activities across all parts of its organisation.

10 SERVICE PROVIDER'S PERSONNEL

- 10.1 The Service Provider's Personnel shall be regarded at all times as employees, agents or Subcontractors of the Service Provider and no relationship of employer and employee shall arise between Transnet and any Service Provider Personnel under any circumstances regardless of the degree of supervision that may be exercised over the Personnel by Transnet.
- 10.2 The Service Provider warrants that all its Personnel will be entitled to work in South Africa or any other country in which the Services are to be performed.
- 10.3 The Service Provider will ensure that its Personnel comply with all reasonable requirements made known to the Service Provider by Transnet concerning conduct at any Transnet premises or any other premises upon which the Services are to be performed [including but not limited to security regulations, policy standards and codes of practice and health and safety requirements]. The Service Provider will ensure that such Personnel at all times act in a lawful and proper manner in accordance with these requirements.
- 10.4 Transnet reserves the right to refuse to admit or to remove from any premises occupied by or on behalf of it, any Service Provider Personnel whose admission or presence would, in the reasonable opinion of Transnet, be undesirable or who represents a threat to confidentiality or security or whose presence would be in breach of any rules and regulations governing Transnet's Personnel, provided that Transnet notifies the Service Provider of any such refusal [with reasons why]. The reasonable exclusion of any such individual from such premises shall not relieve the Service Provider from the performance of its obligations under this Agreement.
- 10.5 The Service Provider agrees to use all reasonable endeavours to ensure the continuity of its Personnel assigned to perform the Services. If any re-assignment by the Service Provider of those Personnel is necessary, or if Transnet advises that any such Personnel assigned are in any respect unsatisfactory, including where any such Personnel are, or are expected to be or have been absent for any period, then the Service Provider will promptly supply a replacement of equivalent calibre and experience, and any such replacement shall be approved by Transnet prior to commencing provision of the Services, such approval not to be unreasonably withheld or delayed.

11 SUBCONTRACTING

- 11.1 The Supplier may only enter into a subcontracting arrangement or replace a subcontractor with the approval of Transnet.
- 11.2 If the Supplier subcontracts a portion of the contract to another person without declaring it to Transnet reserves the right to penalise the Supplier up to 10% of the value of the contract.
- 11.3 Where the Supplier seeks to replace a subcontractor Transnet shall be entitled to obtain representations or input from the initial subcontractor who was part of the tender process whose credentials were used in the Supplier's tender submission. Transnet shall consider input from all parties concerned, in order to take a decision on the proposed replacement of the subcontractor. The subcontracting arrangement or contract remains between the Supplier (main contractor) and the subcontractor.

- 11.4 Should Transnet approve the Supplier's/Service Provider's subcontracting arrangement, the Supplier and not the Sub-contractor will at all times be held liable for performance in terms of its contractual obligations.
- 11.5 The Supplier may not subcontract in such a manner that the the overall value of the contract is reduced to below the stipulated minimum threshold.
- 11.6 The Supplier may not subcontract more than 25% of the value of the contract to any other enterprise that does not have an equal or higher B-BBEE status level of contributor than the Supplier, unless the contract is subcontracted to an Exempted Micro Enterprise (EME) that has the capability and ability to execute the Subcontract.

12 PAYMENT TO SUB-CONTRACTORS

- 12.1 Transnet reserves the right, in its sole discretion, to make payment directly to the sub-contractor of the Supplier, subject to the following conditions:
 - a) Receipt of an undisputed invoice from the sub-contractor; and
 - b) Receipt of written confirmation from the Supplier that the amounts claimed by the sub-contractor are correct and that the services for which the sub-contractor has requested payment were rendered to the satisfaction of the Supplier, against the required standards.
- 12.2 Nothing contained in this clause must be interpreted as bestowing on any sub-contractor a right or legitimate expectation to be paid directly by Transnet. Furthermore, this clause does not bestow any right or legitimate expectation on the Supplier to demand that Transnet pay its sub-contractor directly. The decision to pay any sub-contractor directly, remains that of Transnet alone.
- 12.3 The Supplier remains liable for its contractual obligations under the Agreement, including all services rendered by the sub-contractor.
- 12.4 This clause does not establish any contractual relationship between Transnet and any sub-contractor of the Supplier, whatsoever.

13 B-BBEE AND SOCIO-ECONOMIC OBLIGATIONS

13.1 B-BBEE Scorecard

- a) Transnet fully endorses and supports the Broad-Based Black Economic Empowerment Programme and is strongly of the opinion that all South African business enterprises have an equal obligation to redress the imbalances of the past.
- b) In response to this requirement, the Supplier shall submit to Transnet's Contract Manager or such other designated person details of its B-BBEE status in terms of the latest Codes of Good Practice issued in terms of the B-BBEE Act and proof thereof at the beginning of March each year during the currency of this Agreement.
- c) The Supplier undertakes to notify and provide full details to Transnet in the event there is:
 - (i) a change in the Supplier's/Service Provider's B-BBEE status which is less than what it was at the time of its appointment including the impact thereof; and
 - (ii) a corporate or internal restructure or change in control of the Supplier which has or likely to impact negatively on the Supplier's/ Service Provider's B-BBEE status.

- d) Notwithstanding any other reporting requirement in terms hereof, the Supplier Service Provider undertakes to provide any B-BBEE data (underlying data relating to the Supplier /Service Provider which has been relied upon or utilised by a verification agency or auditor for the purposes of issuing a verification certificate in respect of the Supplier B-BBEE status) which Transnet may request on written notice within 30 (thirty) calendar days of such request. A failure to provide such data shall constitute a Supplier/ Service Provider Default and may be dealt with in accordance with the provisions of clause 269.
- e) In the event there is a change in the Supplier's/ Service Provider's B-BBEE status, then the provisions of clause 269 shall apply.

13.2 Green Economy/Carbon Footprint

- a) The Supplier has in its bid provided Transnet with an understanding of the Supplier's/Service Provider's position with regard to issues such as waste disposal, recycling and energy conservation.

13.3 Reporting

- a) The Supplier shall monitor, audit, and record in an auditable manner, its own implementation and compliance with its Local Content obligations (if applicable) and provide the Contract Manager with such information as the Contract Manager may reasonably request concerning its Local Content obligations.
- b) The Supplier shall, on a monthly basis from the Commencement Date and within 7 (seven) calendar days of the end of the previous calendar month, provide Transnet with a report (for monitoring purposes only) in respect of each of the undertakings stipulated in this clause.

14 LOCAL CONTENT OBLIGATIONS

- 14.1 In terms of Annexure A (SBD 6.2) and Annexure C of the RFP, the Supplier has undertaken to implement the local content and production requirements set by National Treasury for the designated sector ("local content undertaking"). It is recorded that the local content undertaking was a prequalification criterion of the RFP and it is therefore mandatory for the Supplier to comply with Annexures A and C in order for it to fulfil its local content obligations.
- 14.2 The Supplier is required to note that Transnet, the Department of Trade, Industry and Competition [DTIC] and/or the body appointed by the DTIC as the verification authority for local content may conduct compliance audits with regard to the local content requirements as prescribed in Regulation 9 of the Preferential Procurement Regulations, 2011 issued in terms of the Preferential Procurement Policy Framework Act.
- 14.3 The Supplier is required to continuously update Declarations C, D and E of the Local Content Declaration templates with the actual local content values for the duration of the contract.
- 14.4 Breach of Local Content obligations also provides Transnet cause to terminate the contract in certain cases where material non compliance with Local Content requirements are not achieved.

14.5 Non-compliance Penalties for Local Content:

- a) The Parties have agreed on the following milestone targets ("the Local Content Plan"):
.....

- b) If for any reason the Supplier is unable to achieve any milestone target indicated in the Local Content Plan **OR** the local content undertaking the Supplier must approach the Department of Trade and Industry ("DTI") to obtain exemption in order to supply the goods at a lower local content threshold. The Supplier is obliged to approach DTI for exemption within 10 (ten) days of determining that it is unable to achieve any milestone target or local content threshold.
- c) Should the DTI provide exemption, the Supplier shall be entitled to provide the goods at the lower local content threshold set by DTI. In such event, the Parties shall in good faith renegotiate the milestone targets or local content undertaking to ensure that the lowered local content thresholds are achieved.
- d) Should DTI not provide the necessary exemption, the Supplier shall be obliged to meet each milestone target as stated in the Local Content Plan or the local content undertaking.
- e) Should the Supplier fail to meet any milestone target or the local content undertaking, the following remedies shall apply without limiting any of Transnet's other rights in law:
 - i. Transnet shall afford the Supplier a period of thirty (30) days to remedy its non-compliance.
 - ii. Should the Supplier fail to meet its obligations within the further 30 day period, the Supplier shall pay a Non-Compliance penalty ("Non-compliance Penalty") to Transnet in respect of such Non-compliance as set out in clause iv below. The penalties shall be imposed per milestone measurement for non-delivery of committed values in the case of a Local Content Plan or shall be imposed against the non-delivery of committed values where local content undertakings must be met immediately.
 - iii. To the extent that the Actual Local Content Spend¹ is lower than the Required Local Content Spend² (or the Adjusted Required Local Content Spend³, as the case may be), the Supplier shall be liable for Penalties which is the difference in value between the Actual Local Content Spend and the Required Local Content Spend (or the Adjusted Required Local Content Spend, as the case may be) plus an additional percentage of such difference. Such Non-compliance Penalties shall be calculated and levied at the relevant milestones as stipulated in the Local Content Plan or shall be imposed against the non-delivery of committed values where local content undertakings must be met immediately, in accordance with clause iv below.
 - iv. Non-compliance penalties shall apply at the following rate: the difference in value between the Required Local Content Spend and the Actual Local Content Spend, plus 5% of such difference.
 - v. In order to guarantee that the Supplier meets its obligations in terms of the Local Content Plan or its committed local content undertaking, Transnet shall be entitled to retain a Non-compliance Penalty at the rate of 2% of every monthly payment due by

¹ Actual Local Content Spend means the monetary value of local content initiatives actually delivered by the Supplier during the period under review.

² Required Local Content Spend means the monetary value of local content obligations that the Supplier has agreed to deliver during the period under review.

³ Adjusted Required Local Content Spend means any adjustment to the Required Local Content Spend as prescribed by DTI through the process of exemption referred to in clause c) above and as agreed to between the parties, reduced to writing and signed by the parties.

Transnet to the Supplier over the contract period ("the Local Content Retention Amount"). The Local Content Retention Amount shall be set off against any penalties payable by the Supplier at any milestone assessment.

- f) Should no penalties be imposed during the duration of the contract, Transnet shall refund the full value of the Local Content Retention Amount to the Supplier at the end of the contract period.
- g) Should any unpaid penalties remain at the end of the contract period, then without limiting other rights that Transnet may have in law, the Supplier shall forfeit the Local Content Retention Amount and shall have no further claim against Transnet for the repayment of such amount.

Non-compliance Penalty Certificate:

- h) If any Non-compliance Penalty arises, the Supplier Development Manager shall issue a Non-compliance Penalty Certificate on the last day of each month during such Non-compliance indicating the Non-compliance Penalties which have accrued during that period.
- i) A Non-compliance Penalty Certificate shall be prima facie proof of the matters to which it relates. If the Supplier disputes any of the amounts set out in a Non-compliance Penalty Certificate:
 - the dispute shall be resolved in accordance with the provisions of the Agreement; and
 - if pursuant to that referral, it is determined that the Supplier owes any amount to Transnet pursuant to the Non-compliance Penalty Certificate, then the Supplier shall pay such amount to Transnet within 10 (ten) Business Days of the determination made pursuant to such determination and an accompanying valid Tax Invoice.

Payment of Non-compliance Penalties:

- j) Subject to Clause i) above, the Supplier shall pay the Non-compliance Penalty indicated in the Non-compliance Penalty Certificate within 10 (ten) Business Days of Transnet issuing a valid Tax Invoice to the Supplier for the amount set out in that certificate. If Transnet does not issue a valid Tax Invoice to the Supplier for Non-compliance Penalties accrued during any relevant period, those Non-compliance Penalties shall be carried forward to the next period.
- k) The Supplier shall pay the amount due within 10 (ten) days after receipt of a valid Tax Invoice from Transnet, failing which Transnet shall, without prejudice to any other rights of Transnet under this Agreement, be entitled to call for payment which may be in any form Transnet deems reasonable and appropriate.
- l) It is agreed that Transnet, the DTI, the South African Bureau of Standards and/or any of their appointed agents shall be entitled to monitor, evaluate and audit the Contractor's compliance with its obligations under the Local Content Plan. To this end, the Contractor shall provide its full cooperation to the respective bodies referred to in this clause to ensure that effective monitoring, evaluation and auditing takes place.
- m) The Non Compliance Penalties set forth in this Clause are stated exclusive of VAT. Any VAT payable on Non Compliance Penalties will be for the account of the Supplier.

Payment of Non-compliance Penalties:

- n) Subject to Clause (e) above, the Supplier shall pay the Non-compliance Penalty indicated in the Non-compliance Penalty Certificate within 10 (ten) Business Days of Transnet issuing a valid Tax Invoice to the Supplier for the amount set out in that certificate. If Transnet does not issue a valid Tax Invoice to the Supplier for Non-compliance Penalties accrued during any relevant period, those Non-compliance Penalties shall be carried forward to the next period.
- o) The Supplier shall pay the amount due within 10 (ten) days after receipt of a valid Tax Invoice from Transnet, failing which Transnet shall, without prejudice to any other rights of Transnet under this Agreement, be entitled to call for payment which may be in any form Transnet deems reasonable and/or appropriate.
- p) Should the Supplier fail to pay any Non Compliance Penalties within the time indicated above (as applicable), Transnet shall be entitled to deduct (set off) the amount not paid by the Supplier from the account of the Supplier in the ensuing month.
- q) The Non Compliance Penalties set forth in this Clause are stated exclusive of VAT. Any VAT payable on Non Compliance Penalties will be for the account of the Supplier.

14.6 Non-compliance penalties for Job Creation

- a) Breach of job creation obligations provides Transnet cause to terminate the contract in certain cases where there is a material Non-compliance.
- b) If the Supplier fails to achieve its job creation commitments as per their bid submission ("a **Non-Compliance**"), the Supplier shall pay a Non-Compliance penalty ("Non-compliance Penalty") to Transnet in respect of such Non-compliance.
- c) Such penalty shall be calculated based on the difference between the committed and delivered jobs. For every job not created, a penalty of 2% of the contract value will be applied.

Non-compliance Penalty Certificate:

- d) If any Non-compliance Penalty arises, the Supplier Development Manager shall issue a Non-compliance Penalty Certificate **90 business days** before the expiry of the contract indicating the Non-compliance Penalties which have accrued during that period.
- e) A Non-compliance Penalty Certificate shall be prima facie proof of the matters to which it relates. If the Supplier disputes any of the amounts set out in a Non-compliance Penalty Certificate:
 - the dispute shall be resolved in accordance with the provisions of the Agreement; and
 - if pursuant to that referral, it is determined that the Supplier owes any amount to Transnet pursuant to the Non-compliance Penalty Certificate, then the Supplier shall pay such amount to Transnet within 10 (ten) Business Days of the determination made pursuant to such determination and an accompanying valid Tax Invoice.

Payment of Non-compliance Penalties:

- f) Subject to Clause (e) above, the Supplier shall pay the Non-compliance Penalty indicated in the Non-compliance Penalty Certificate within 10 (ten) Business Days of Transnet issuing a valid Tax Invoice to the Supplier for the amount set out in that certificate. If Transnet does not issue a valid Tax Invoice to the Supplier for Non-compliance Penalties accrued during

any relevant period, those Non-compliance Penalties shall be carried forward to the next period.

- g) The Supplier shall pay the amount due within 10 (ten) days after receipt of a valid Tax Invoice from Transnet, failing which Transnet shall, without prejudice to any other rights of Transnet under this Agreement, be entitled to call for payment which may be in any form Transnet deems reasonable and/or appropriate.
- h) Should the Supplier fail to pay any Non Compliance Penalties within the time indicated above (as applicable), Transnet shall be entitled to deduct (set off) the amount not paid by the Supplier from the account of the Supplier in the ensuing month.

The Non Compliance Penalties set forth in this Clause are stated exclusive of VAT. Any VAT payable on Non Compliance Penalties will be for the account of the Supplier.

15 FEES AND EXPENSES RELATING TO SERVICES

- 15.1 In consideration of the provision of the Services, Transnet will pay to the Service Provider the Fees detailed in the relevant schedule or Work Order.
- 15.2 Transnet will not be invoiced for materials used in the provision of the Services save for those materials [if any] set out in the Work Order and accepted by Transnet or in any relevant Work Order [which will be invoiced to Transnet at cost].
- 15.3 Unless otherwise agreed in a schedule or Work Order, Transnet will reimburse to the Service Provider all reasonable and proper expenses incurred directly and solely in connection with the provision of the Services, provided that all such expenses:
 - a) are agreed by Transnet in advance;
 - b) are incurred in accordance with Transnet's standard travel and expenses policies;
 - c) are passed on to Transnet at cost with no administration fee; and
 - d) will only be reimbursed if supported by relevant receipts.
- 15.4 All Tax Invoices relating to Fees, out of pocket expenses and, if applicable, travel and accommodation costs, will provide the detail for each of the Personnel carrying out the Services and incurring the expenses, and the Tax Invoice will, where appropriate, include VAT as a separate item.

16 INVOICES AND PAYMENT

- 16.1 Transnet shall pay the Supplier the amounts stipulated in each Purchase Order/Work Order, subject to the terms and conditions of this Agreement.
- 16.2 Transnet shall pay such amounts to the Supplier upon receipt of a valid and undisputed Tax Invoice together with the supporting documentation, as specified in the Schedule of Requirements appended hereto, once the valid and undisputed Tax Invoices or such portions of the Tax Invoices which are valid and undisputed become due and payable to the Supplier for the delivery of the Services ordered, in terms of clause 16.5 below.
- 16.3 Transnet may, pending an investigation, withhold any payments to the Supplier, in the case where irregular expenditure has been identified in the particular contract and that there is reasonable suspicion that the Supplier is involved or was aware that the contract transgressed any legislation.

- 16.4 All Prices set out in this Agreement and the Schedule of Requirements hereto are to be indicated inclusive and exclusive of VAT, which will be payable at the applicable rate in ZAR.
- 16.5 Unless otherwise provided for in the Schedule of Requirements appended to this Agreement, Tax Invoices shall be submitted together with a month-end statement. Payment against such month-end statement shall be made by Transnet within 30 [thirty] calendar days after date of receipt by Transnet of the Supplier's/Service Provider's statement together with the relevant valid and undisputed Tax Invoice(s) and supporting documentation.
- 16.6 Where the payment of any Tax Invoice, or any part of a Tax Invoice which is not in dispute, is not made in accordance with this clause, the Supplier shall be entitled to charge interest on the outstanding amount, at The Standard Bank of South Africa's prime rate of interest in force, for the period from the due date of payment until the outstanding amount is paid.
- 16.7 The Supplier shall remain the owner of all plant, material, machinery, equipment and the like [collectively, **the Supplier's Goods**] provided to Transnet until Transnet has paid in full for the Supplier's Goods, it being specifically agreed that Transnet shall acquire no rights [including liens] of whatsoever nature in such Supplier's Goods until date of final payment by Transnet. Subject to the foregoing, all risk and benefit to the Supplier's Goods shall pass from the Supplier to Transnet on delivery of the Supplier's Goods by the Supplier to Transnet.

17 PRICE ADJUSTMENTS

- 17.1 Prices for Services supplied in terms of this Agreement shall be subject to review as indicated in the Schedule of Requirements/Works Order annexed hereto.
- 17.2 No less than 2 [two] months prior to any proposed Price adjustment, the Parties shall commence negotiations for Prices for the next period or as otherwise indicated in Schedule 1 hereto. The Parties shall have regard for market-related pricing of equivalent goods, continuous improvement initiatives, costs [including labour, raw materials and transport/delivery], order size and frequency and changes to the specification of the Goods/Services.
- 17.3 Pursuant to clause 17.2 above, the Supplier shall keep full and accurate records of all costs associated with the supply of the Services to Transnet, in a form to be approved in writing by Transnet. The Supplier shall produce such records to Transnet for inspection at all reasonable times on request and such records may, at Transnet's option, be audited by Transnet or its designated representatives.
- 17.4 Should Transnet and the Supplier fail to reach an agreement on Price for the successive period, either Party shall be entitled to submit this matter to dispute resolution in accordance with clause 39 of the Master Agreement [Dispute Resolution].
- 17.5 If during the period of this Agreement Transnet can purchase similar Services of a like quality from another supplier at a total delivered cost to a Transnet facility that is lower than the total delivered cost of the Services purchased hereunder from the Supplier, Transnet may notify the Supplier of such total delivered cost and the Supplier shall have an opportunity to adjust the Price of the Services purchased hereunder, on such a basis as to result in the same total delivered cost to Transnet, within 30 [thirty] calendar days of such notice. If the Supplier fails to do so or cannot legally do so, Transnet may (i) purchase the Services from such other supplier in which case the obligations, including, but not limited to, any purchase and sale requirements and/or commitments, if any, of Transnet and the Supplier hereunder shall be reduced accordingly; (ii)

terminate this Agreement without any penalty, liability or further obligation; or (iii) continue purchases under this Agreement.

- 17.6 If during the period of this Agreement the Supplier sells any materials which are the same as, equivalent to, or substantially similar to the Services herein, at a total delivered cost to a third party lower than the total delivered cost to a Transnet facility, then the Supplier has an opportunity to adjust its Price for the Services purchased hereunder within 30 [thirty] calendar days so that the Price is the same or lower than the total delivered cost of such third party. If the Supplier fails to do so or cannot legally do so, Transnet may (i) purchase the Services from any other such supplier, in which case the obligations, including, but not limited to, any purchase and sale requirements and/or commitments, if any, of Transnet and the Supplier hereunder shall be reduced accordingly; or (ii) terminate this Agreement without any penalty, liability or further obligation. Within 30 [thirty] calendar days of the Commencement Date of this Agreement or at any time Transnet so requests, the Supplier shall certify in writing to Transnet that it is in compliance with this clause and shall provide all information that Transnet reasonably requests in order to verify such compliance.

18 WARRANTIES APPLICABLE TO GOODS

The Supplier warrants that:

- 18.1 pursuant to clause 9.3 [General Obligations of the Supplier], the Goods will be manufactured in accordance with the specifications appended hereto at Schedule 1, or the manufacturer's specifications, as agreed in writing by both Parties;
- 18.2 the execution and performance of this Agreement by the Supplier does not infringe any rights of a third party or breach any obligation of the Supplier to any third party; and
- 18.3 it has taken all reasonable precautions to ensure that, in the event of a disaster, the impact of such disaster on the ability of the Supplier to comply with its obligations under this Agreement will be reduced to the greatest extent possible, and that the Supplier shall ensure that it has appropriate, tested and documented recovery arrangements in place.

19 WARRANTIES APPLICABLE TO SERVICES

The Service Provider warrants to Transnet that:

- a) it has full capacity and authority to enter into and to perform this Agreement and that this Agreement is executed by a duly authorised representatives of the Service Provider;
- b) it will discharge its obligations under this Agreement and any annexure, appendix or schedule hereto with all due skill, care and diligence;
- c) it will be solely responsible for the payment of remuneration and associated benefits, if any, of its Personnel and for withholding and remitting income tax for its Personnel in conformance with any applicable laws and regulations;
- d) it will procure licences for Transnet in respect of all Third Party Material detailed in the Work Order(s), and will procure the right for Transnet to take such copies [in whole or in part] of such Third Party Materials as it may reasonably require for the purposes of back-up for archiving and disaster recovery; and

- e) the use or possession by Transnet of any Materials will not subject Transnet to any claim for infringement of any Intellectual Property Rights of any third party.
- 19.2 The Service Provider warrants that it will perform its obligations under this Agreement in accordance with the Service Levels as defined in the relevant schedule. Transnet may at its discretion audit compliance with the Service Levels, provided that any such audit is carried out with reasonable prior notice and in a reasonable way so as not to have an adverse effect on the performance of the Services. Without prejudice to clause 19.3 below, in the event that the Service Provider fails to meet the Service Levels, Transnet may claim appropriate service credits or invoke a retention of Fees as detailed in the relevant schedule and/or Work Order.
- 19.3 The Service Provider warrants that for a period of 90 [ninety] calendar days from Acceptance of the Deliverables they will, if properly used, conform in all material respects with the requirements set out in the relevant schedule. The Service Provider will at its expense remedy any such non-conformance as soon as possible but in any event within 30 [thirty] calendar days of notification by Transnet. In the event that the Service Provider fails or is unable to remedy such non-conformance within such time-scale, Transnet will be entitled to employ a third party to do so in place of the Service Provider and any excess charges or costs incurred by Transnet as a result shall be paid by the Service Provider.
- 19.4 The Service Provider will remedy any defect within 30 [thirty] calendar days of being notified of that defect by Transnet in writing.
- 19.5 The Service Provider will not be liable to remedy any problem arising from or caused by any modification made by Transnet to the Deliverables, or any part thereof, without the prior approval of the Service Provider.
- 19.6 The Service Provider shall advise Transnet of the effects of any steps proposed by Transnet pursuant to clause 19.5 above, including but not limited to any cost implications or any disruption or delay in the performance of the Services. The Parties agree that any changes to the Services, including the charges for the Services or any timetables for delivery of the Services, will be agreed in accordance with the change control procedure, as set out in clause 392 [*Amendment and Change Control*].
- 19.7 The Service Provider warrants that:
- a) it has, using the most up-to-date software available, tested for [and deleted] all commonly known viruses in the Materials and for all viruses known by the Service Provider at the date of the relevant Work Order; and
 - b) at the time of delivery to Transnet, the Materials do not contain any trojan horse, worm, logic bomb, time bomb, back door, trap door, keys or other harmful components.
- The Service Provider agrees that, in the event that a virus is found, it will at its own expense use its best endeavours to assist Transnet in reducing the effect of the virus and, particularly in the event that a virus causes loss of operational efficiency or loss of data, to assist Transnet to the same extent to mitigate such losses and to restore Transnet to its original operating efficiency.
- 19.8 The Service Provider undertakes to comply with South Africa's general privacy protection in terms of Section 14 of the Bill of Rights in connection with this Agreement and shall procure that its Personnel shall observe the provisions of Section 14 [as applicable] or any amendments and re-enactments thereof and any regulations made pursuant thereto.

- 19.9 The Service Provider warrants that it has taken all reasonable precautions to ensure that, in the event of a disaster, the impact of such disaster on the ability of the Service Provider to comply with its obligations under this Agreement will be reduced to the greatest extent possible, and that the Service Provider shall ensure that it has appropriate, tested and documented recovery arrangements in place.
- 19.10 In compliance with the National Railway Safety Regulator Act, 16 of 2002, the Service Provider shall ensure that the Services, to be supplied to Transnet under the terms and conditions of this Agreement, comply fully with the specifications as set forth in Schedule 1 hereto, and shall thereby adhere [as applicable] to railway safety requirements and/or regulations. Permission for the engagement of a Subcontractor by the Service Provider [as applicable] shall be subject to a review of the capability of the proposed Subcontractor to comply with the specified railway safety requirements and/or regulations. The Service Provider and/or its Subcontractor shall grant Transnet access, during the term of this Agreement, to review any safety-related activities, including the coordination of such activities across all parts of its organisation.

20 THIRD PARTY INDEMNITY

The Supplier hereby indemnifies and shall hold Transnet harmless against any direct damages suffered by or claims arising against Transnet in respect of clause 18.2 above.

21 INSPECTION APPLICABLE TO GOODS

- 21.1 Transnet reserves the right to arrange for the inspection of all Goods forming the subject of any Purchase Order, at any stage before final acceptance and by any means it may think fit, and when such inspection is to be carried out, the relevant Purchase Order(s) shall be endorsed accordingly.
- 21.2 When inspection at the Supplier's works or warehouse is specified, Transnet's authorised inspector shall have free access to the premises of the Supplier at all times during working hours on a Business Day; shall have liberty to inspect work which is the subject of the Purchase Order at any stage of manufacture, and may reject any Goods which are found to be incomplete, defective or in any way not in conformity with the terms and specifications of this Agreement; and the Supplier shall afford all reasonable facilities for such access and inspection.
- 21.3 The Supplier shall provide inspection gauges, measuring and test equipment to ensure that the requirements of this Agreement are satisfied. All gauges, templates, tools and other equipment required to check the accuracy of the work shall be calibrated at regular and reasonable intervals by a laboratory which has been approved in writing by Transnet. This certificate shall not be more than 12 [twelve] months old.
- 21.4 The Supplier shall prepare and supply, without charge to Transnet, all test pieces, samples and specimens; shall provide all labour and apparatus for carrying out tests and analyses in accordance with the terms of this Agreement or Purchase Order, and render all reasonable assistance in making such tests and analyses.
- 21.5 All special rules governing gauging, testing, analysis and other inspection procedures shall be adhered to strictly in accordance with the terms of this Agreement or Purchase Order and the conditions of any specifications and drawings quoted therein.
- 21.6 Inspection will be arranged by the Staff of Transnet, as indicated in the Purchase Order(s).

- 21.7 When Goods are ready for inspection, the Supplier shall apply promptly to the appropriate authority for instructions regarding such inspection. All applications for inspection shall quote Transnet's Agreement or Purchase Order number. 7 [seven] Business Days' notice of readiness from the Supplier shall be given to the authorised inspector appointed by Transnet to carry out such inspection.
- 21.8 Transnet shall have the right to recover from the Supplier the cost of inspection of any Goods that have been rejected by its authorised inspector in terms of this clause 214.

22 DEFECTIVE GOODS

- 22.1 Notwithstanding any certificate and/or receipt that may have been issued by or on behalf of Transnet either in South Africa or overseas, Goods will be accepted at the place of delivery or at the port of shipment, as specified in this Agreement, only as regards outward condition of packages and Transnet retains the right to reject the Goods supplied, on or after arrival at the place to which they are consigned, or after they have been placed in use in South Africa, should they be found defective.
- 22.2 If Goods are rejected owing to latent defects becoming apparent during machining operations or other preparation necessary on the part of Transnet before they can be put into use, the Supplier shall bear all expenses incurred by Transnet in carrying out such necessary operations.
- 22.3 If such Goods are rejected, the Supplier will pay the following costs:
- a) for Goods purchased in South Africa on an ex works basis, the cost of transport from the Supplier's works in South Africa to the named destination where the Goods have been rejected by Transnet, plus handling charges and storage, if leviable; or
 - b) for Goods manufactured overseas, the Supplier shall pay all replacement costs including the overseas inland transport cost, freight and insurance charges incurred plus railage or other inland transport costs from the South African port to the place where the Goods have been rejected by Transnet, including handling charges, storage, landing charges, customs duty and surcharges, if leviable.
- 22.4 If Transnet requires rejected Goods to be replaced, the Supplier shall, when called upon to do so, arrange prompt replacement of the Goods within the prescribed manufacturing lead times for such Goods, as indicated in Schedule 1.
- 22.5 If Goods are found to be defective but the defects are, in the opinion of Transnet, not of so serious a nature as to warrant total rejection of the Goods, the Supplier shall, when called upon to do so, remedy or make good such defects at its own cost, or Transnet may remedy or make good such defects at the request of the Supplier and recover from the Supplier all costs or expenses reasonably incurred by it in doing so.
- 22.6 Should the Supplier fail, when called upon to remedy or make good such defects within a reasonable time or to request Transnet to do so, Transnet may proceed to remedy or make good such defects and thereafter recover from the Supplier all such costs and expenses as aforementioned.
- 22.7 Any amount recoverable from the Supplier in terms of this clause may, without prejudice to any other legal remedies available to Transnet, be deducted in whole or in part from any monies in the hands of Transnet which are due for payment to the Supplier.

23 TOTAL OR PARTIAL FAILURE TO PERFORM

23.1 In the case of Goods to be specially manufactured for it, if Transnet at any time ascertains that:

- a) no manufacturing of the Goods specified in a Purchase Order has commenced and there is little or no prospect, in Transnet's opinion, that manufacturing will commence within a reasonable time; or
- b) delivery of any of the Goods is being or is likely to be delayed beyond the promised delivery date(s), and there is little or no prospect of the Purchase Order(s) being carried out within reasonable adherence to the promised delivery rate(s) or time(s),

then Transnet may, irrespective of the cause of the delay, by notice to the Supplier, cancel as from a future date specified in such notice the whole or any part of this Agreement or Purchase Order in respect of which the Goods to be supplied have not been completed by that date, without incurring any liability by reason of such cancellation except as provided in this clause.

23.2 The Supplier shall thereupon, as soon as possible after such date, deliver to Transnet the Services [if any] already completed, and payment for the part performance shall be made on a pro rata basis, provided the uncompleted part is not an integral or essential part of the completed Goods/Services. Where an integral or essential part of the work has not been completed, the amount to be paid to the Supplier will be calculated on the basis of Transnet's enrichment. The Supplier shall, wherever practicable, supply Transnet with the necessary drawings and/or specifications to enable it to complete the work.

23.3 Whenever, in any case not covered by clause 23.1 above, the Supplier fails or neglects to execute the work or to deliver any portion of the Services as required by the terms of this Agreement or Purchase Order, or if any Services are rejected on any of the grounds mentioned in clause 225 [Defective Goods], Transnet may cancel this Agreement or Purchase Order in so far as it relates to the unexecuted work or the undelivered or rejected portion of the Goods/Services, and in such event, the supply of the remaining portion shall remain subject in all respects to these conditions.

24 NON CONFORMANCE OF SERVICES PROCURED

24.1 *In the case of Services manufactured for and procured by Transnet from the Supplier in terms of this Agreement, being found not to conform to the Transnet standards, specifications and requirements, Transnet at any time may be entitled to raise a Non Conformance Report (NCR) against a Supplier whose Goods/ Services do not conform to Transnet standards, specifications and requirements directing the Supplier to investigate and remedy the non-conformance within the stipulated time frame as may be determined by Transnet at its discretion.*

24.2 *Failure by the Supplier to fully comply with NCR within the period stated in sub-clause 26.1 above, shall entitle Transnet to further conditions to which the Supplier/ Service Provider must discharge in order to close the NCR or to terminate the order without giving the Supplier written notice of termination in terms of this Agreement.*

25 RIGHTS ON CANCELLATION

25.1 If this Agreement or Purchase Order is cancelled in whole or in part in terms of clause 236 [Total or Partial Failure to Perform], Transnet may execute or complete this Agreement with any other entity and do so on such terms as it may deem proper, or may procure other comparable Services in substitution for those neglected to be manufactured or supplied or rejected as aforesaid, and may

recover from the Supplier the difference between the cost of such Services and the Price [if the latter was lower] as well as any costs and expenses [including any additional transport costs] which Transnet may have had to incur in consequence of the Supplier's/Service Provider's default.

- 25.2 Any amount which may be recoverable from the Supplier in terms of clause 25.1 above, without prejudice to any other legal remedies available to Transnet, may be deducted in whole or in part from any monies in the hands of Transnet and due for payment to the Supplier.

26 BREACH AND TERMINATION

- 26.1 Termination in accordance with clause 6 [Term and Cancellation] shall not prejudice or affect any right of action or remedy which shall have accrued or shall thereafter accrue to either Party and all provisions which are to survive this Agreement or impliedly do so shall remain in force and in effect.
- 26.2 On termination of this Agreement or a Work Order, the Service Provider will immediately deliver up, and procure that its Personnel will immediately deliver up to Transnet, all Deliverables and property belonging to Transnet [or, in the event of termination of a Work Order, such as is relevant to that Work Order] which may be in the possession of, or under the control of the Service Provider, and certify to Transnet in writing that this has been done.
- 26.3 To the extent that any of the Deliverables and property referred to in clause 26.2 above are in electronic form and contained on non-detachable storage devices, the Service Provider will provide Transnet with unencrypted copies of the same on magnetic media and will irretrievably destroy and delete copies so held.
- 26.4 In the event that this Agreement is terminated by the Service Provider under clause **Error! Reference source not found.** [Term and Cancellation], or in the event that a Work Order is terminated by Transnet under clause **Error! Reference source not found.** [Breach and Consequences of Termination], Transnet will pay to the Service Provider all outstanding Fees [apportioned on a pro rata basis] relating to the work undertaken by the Service Provider up until the date of such termination. Transnet will also pay the costs of any goods and materials ordered by the Service Provider in relation to the such work for which the Service Provider has paid or is legally obliged to pay, in which case, on delivery of such goods or materials, the Service Provider will promptly deliver such goods and materials to Transnet or as it may direct.
- 26.5 If either Party [**the Defaulting Party**] commits a material breach of this Agreement and fails to remedy such breach within 30 [thirty] calendar days of written notice thereof, the other Party [hereinafter **the Aggrieved Party**], shall be entitled, in addition to any other rights and remedies that it may have in terms of this Agreement, to terminate this Agreement forthwith without any liability and without prejudice to any claims which the Aggrieved Party may have for damages against the Defaulting Party.
- 26.6 Either Party may terminate this Agreement forthwith by notice in writing to the other Party when the other Party is unable to pay its debts as they fall due or commits any act or omission which would be an act of insolvency in terms of the Insolvency Act, 24 of 1936 [as amended from time to time], or if any action, application or proceeding is made with regard to it for:
- a) a voluntary arrangement or composition or reconstruction of its debts;
 - b) its winding-up or dissolution;
 - c) the appointment of a liquidator, trustee, receiver, administrative receiver or similar officer;

d) any similar action, application or proceeding in any jurisdiction to which it is subject.

26.7 Transnet may terminate this Agreement at any time within 2 [two] months of becoming aware of a change of control of the Supplier by notice in writing to the Supplier. For the purposes of this clause, **control** means the right to direct the affairs of a company whether by ownership of shares, membership of the board of directors, agreement or otherwise.

26.8 Notwithstanding this clause 269, Transnet may cancel this Agreement without cause by giving 30 [thirty] calendar days prior written notice thereof to the Supplier, or

26.9 The provisions of clauses 2 [Definitions], 182 [Warranties], 258 [Rights on Cancellation], 293 [Confidentiality], 325 [Limitation of Liability], 36 [Intellectual Property Rights], 369 [Dispute Resolution] and 40.1 [Governing Law] shall survive termination or expiry of this Agreement.

27 CESSIONS AND ASSIGNMENTS AS PER NT INSTRUCTION NOTE 08 OF 2022/2023

27.1 The Supplier is not allowed to cede its rights for payment in terms of this Agreement without prior written approval from Transnet. Cession shall only be applicable as follows:

- a) Cession must only be applicable to the transfer of right to payment for Services delivered/rendered by a Supplier to an FSP or State Institutions;
- b) The written request for cession must be by the Supplier and not a third party; and
- c) The written request by the Supplier must be accompanied by the cession agreement.

27.2 The Supplier is prohibited from transferring its rights and obligations to perform under this contract. Assignments are against the principles of section 217 of the Constitution mainly, fairness, transparency and competitiveness.

28 FORCE MAJEURE

28.1 Neither Party shall have any claim against the other Party arising from any failure or delay in the performance of any obligation of either Party under this Agreement caused by an act of force majeure such as acts of God, fire, flood, war, lockout, government action, laws or regulations, terrorism or civil disturbance, defaults or other circumstances or factors beyond the reasonable control of either Party, and to the extent that the performance of obligations of either Party hereunder is delayed by virtue of the foregoing, any period stipulated for any such performance shall be reasonably extended. Transnet may however rely on strikes, industrial dispute and riots as a ground of force majeure.

28.2 Each Party will take all reasonable steps by whatever lawful means that are available to resume full performance as soon as practicable and will seek agreement to modification of the relevant provisions of this Agreement in order to accommodate the new circumstances caused by the act of *force majeure*. If a Party fails to agree with such modifications proposed by the other Party within 90 [ninety] calendar days of the act of *force majeure* first occurring, either Party may thereafter terminate this Agreement with immediate notice.

29 PROTECTION OF PERSONAL INFORMATION

a) The following terms shall bear the same meaning as contemplated in Section 1 of the Protection of Personal Information Act 4 of 2013 ("POPIA"):

consent; person; personal information; processing; record; Regulator as well as any terms derived from these terms of the POPIA

- b) Transnet will process all information by the Respondent in terms of the requirements contemplated in Section 4(1) of the POPIA:

Accountability; Processing limitation; Purpose specification; Further processing limitation; Information quality; Openness; Security safeguards and Data subject participation.

- c) Transnet agrees that in submitting any information or documentation requested in the RFP and in this Agreement, the Supplier consents to the processing of their personal information for the purpose of, but not limited to, risk assessment, contract award, contract management, auditing, legal opinions/litigation, investigations (if applicable), document storage for the legislatively required period, destruction, de-identification and publishing of personal information by Transnet and/or its authorised appointed third parties.

- d) The Parties agree that they may obtain and have access to personal information for the fulfilment of the rights and obligations contained herein. In performing the obligations as set out in this Agreement, the Parties shall at all times ensure that:

- i. they process personal information only for the express purpose for which it was obtained;
- ii. once processed for the purposes for which it was obtained, all personal information will be destroyed to an extent that it cannot be reconstructed to its original form, subject to any legal retention requirements;
- iii. Personal information is provided only to authorised personnel who strictly require the personal information to carry out the Parties' respective obligations under this Agreement;
- iv. they do not disclose personal information of the other Party, other than in terms of this Agreement;
- v. they have all reasonable technical and organisational measures in place to protect all personal information from unauthorised access and/or use;
- vi. they have appropriate technical and organisational measures in place to safeguard the security, integrity and authenticity of all information in their possession or under their control in terms of this Agreement;
- vii. they identify all reasonably foreseeable internal and external risks to personal information in their possession or under their control; establish and maintain appropriate safeguards against the risks identified; regularly verify that the safeguards are effectively implemented; and ensure that the safeguards are continually updated in response to new risks or deficiencies in previously implemented safeguards;
- viii. such personal information is protected against unauthorised or unlawful processing, accidental loss, destruction or damage, alteration, disclosure or access.

- 29.1 The Parties agree that if personal information will be processed for additional purposes beyond the original purpose for which it was obtained, explicit consent must be obtained beforehand from those persons whose information will be subject to such processing.

- 29.2 Should it be necessary for either Party to disclose or otherwise make available the personal information to any third party (including sub-contractors and employees) that is not already consented to, it may do so only with the prior written consent of the other Party. The Party requiring such consent shall require of all such third parties, appropriate written undertakings to be provided, containing similar terms to that set forth in this clause, and dealing with that third party's obligations in respect of its processing of the personal information. Following approval by the other Party, the Party requiring consent agrees that the provisions of this clause shall *mutatis mutandis* apply to all authorised third parties who process personal information.
- 29.3 The Parties shall ensure that any persons authorized to process information on their behalf (including employees and third parties) will safeguard the security, integrity and authenticity of all information. Where necessary to meet this requirement, the Parties shall keep all personal information and any analyses, profiles, or documents derived therefrom logically separated from all other information and documentation held by it.
- 29.4 The Parties shall carry out regular assessments to identify all reasonably foreseeable internal and external risks to the personal information in its possession or under its control. The Parties shall implement and maintain appropriate safeguards against the risks which it identifies and shall also regularly verify that the safeguards which it has in place have been effectively implemented.
- 29.5 The Parties agree that they will promptly return, destroy or de-identify any personal information in their possession or control which belongs to the other Party once it no longer serves the purpose for which it was collected in relation to this Agreement, subject to any legal retention requirements. This may be at the request of the other Party and includes circumstances where a person has requested the Parties to delete all instances of their personal information. The information will be destroyed or de-identified in such a manner that it cannot be reconstructed to its original form, linking it to any particular individual or organisation.
- 29.6 Personal Information security breach:
- a) Each Party shall notify the other party in writing as soon as possible after it becomes aware of or suspects any loss, unauthorised access or unlawful use of any personal information and shall, at its own cost, take all necessary remedial steps to mitigate the extent of the loss or compromise of personal information and to restore the integrity of the affected personal information as quickly as is possible. The Parties shall also be required to provide each other with details of the persons affected by the compromise and the nature and extent of the compromise, including details of the identity of the unauthorised person who may have accessed or acquired the personal information.
 - b) The Parties shall provide on-going updates on the progress in resolving the compromise at reasonable intervals until such time as the compromise is resolved.
 - c) Where required, the Parties must notify the South African Police Service; and/or the State Security Agency and the Information Regulator and the affected persons of the security breach. Any such notification shall always include sufficient information to allow the persons to take protective measures against the potential consequences of the compromise.
 - d) The Parties undertake to co-operate in any investigations relating to security which is carried out by or on behalf of the other including providing any information or material in its possession or control and implementing new security measures.

30 CONFIDENTIALITY

30.1 The Parties hereby undertake the following with regard to Confidential Information:

- a) not to divulge or disclose to any person whomsoever in any form or manner whatsoever, either directly or indirectly, any Confidential Information of the other without the prior written consent of such other Party, other than when called upon to do so in accordance with a statute, or by a court having jurisdiction, or by any other duly authorised and empowered authority or official, in which event the Party concerned shall do what is reasonably possible to inform the other of such a demand and each shall assist the other in seeking appropriate relief or the instituting of a defensive action to protect the Confidential Information concerned;
- b) not to use, exploit, permit the use of, directly or indirectly, or in any other manner whatsoever apply the Confidential Information disclosed to it as a result of this Agreement, for any purpose whatsoever other than for the purpose for which it is disclosed or otherwise than in strict compliance with the provisions in this Agreement;
- c) not to make any notes, sketches, drawings, photographs or copies of any kind of any part of the disclosed Confidential Information without the prior written consent of such other Party, except when reasonably necessary for the purpose of this Agreement, in which case such copies shall be regarded as Confidential Information;
- d) not to de-compile, disassemble or reverse engineer any composition, compilation, concept application, item, component de-compilation, including software or hardware disclosed and shall not analyse any sample provided by Transnet, or otherwise determine the composition or structure or cause to permit these tasks to be carried out except in the performance of its obligations pursuant to this Agreement;
- e) not to exercise less care to safeguard Transnet Confidential Information than the Party exercises in safeguarding its own competitive, sensitive or Confidential Information;
- f) Confidential Information disclosed by either Party to the other or by either Party to any other party used by such party in the performance of this Agreement, shall be dealt with as "restricted" or shall be dealt with according to any other appropriate level of confidentiality relevant to the nature of the information concerned, agreed between the Parties concerned and stipulated in writing for such information in such cases;
- g) the Parties shall not make or permit to be made by any other person subject to their control, any public statements or issue press releases or disclose Confidential Information with regard to any matter related to this Agreement, unless written authorisation to do so has first been obtained from the Party first disclosing such information;
- h) each Party shall be entitled to disclose such aspects of Confidential Information as may be relevant to one or more technically qualified employees or consultants of the Party who are required in the course of their duties to receive the Confidential Information for the Permitted Purpose provided that the employee or consultant concerned has a legitimate interest therein, and then only to the extent necessary for the Permitted Purpose, and is informed by the Party of the confidential nature of the Confidential Information and the obligations of the confidentiality to which such disclosure is subject and the Party shall ensure such employees or consultants honour such obligations;

- i) each Party shall notify the other Party of the name of each person or entity to whom any Confidential Information has been disclosed as soon as practicable after such disclosure;
 - j) each Party shall ensure that any person or entity to which it discloses Confidential Information shall observe and perform all of the covenants the Party has accepted in this Agreement as if such person or entity has signed this Agreement. The Party disclosing the Confidential Information shall be responsible for any breach of the provisions of this Agreement by such person or entity; and
 - k) each Party may by written notice to the other Party specify which of the Party's employees, officers or agents are required to sign a non-disclosure undertaking.
- 30.2 The duties and obligations with regard to Confidential Information in this clause 303 shall not apply where:
- a) a Party can demonstrate that such information is already in the public domain or becomes available to the public through no breach of this Agreement by that Party, or its Staff; or
 - b) was rightfully in a Party's possession prior to receipt from the other Party, as proven by the first-mentioned Party's written records, without an infringement of an obligation or duty of confidentiality; or
 - c) can be proved to have been rightfully received by a Party from a third party without a breach of a duty or obligation of confidentiality; or
 - d) is independently developed by a Party as proven by its written records.
- 30.3 This clause 303 shall survive termination for any reason of this Agreement and shall remain in force and effect from the Commencement Date of this Agreement and 5 [five] years after the termination of this Agreement. Upon termination of this Agreement, all documentation furnished to the Supplier by Transnet pursuant to this Agreement shall be returned to Transnet including, without limitation, all corporate identity equipment including dyes, blocks, labels, advertising matter, printing matter and the like.

31 INSURANCES

- 31.1 Without limiting the liability of the Supplier under this Agreement, the Supplier shall take out insurance in respect of all risks for which it is prudent for the Supplier to insure against, including any liability it may have as a result of its activities under this Agreement for theft, destruction, death or injury to any person and damage to property. The level of insurance will be kept under review by Transnet, on an annual basis, to ensure its adequacy, provided that any variation to the level of such insurance shall be entirely at the discretion of the Supplier.
- 31.2 The Supplier shall arrange insurance with reputable insurers and will produce to Transnet evidence of the existence of the policies on an annual basis within 30 [thirty] calendar days after date of policy renewals.
- 31.3 Subject to clause 31.4 below, if the Supplier fails to effect adequate insurance under this clause 314, it shall notify Transnet in writing as soon as it becomes aware of the reduction or inadequate cover and Transnet may arrange or purchase such insurance on behalf of the Supplier. The Supplier shall promptly reimburse Transnet for any premiums paid provided such insurance protects the Supplier's liability. Transnet assumes no responsibility for such insurance being adequate to protect all of the Supplier's liability.

- 31.4 In the event that the Supplier receives written notice from its insurers advising of the termination of its insurance cover referred to in clause 31.1 above or if the insurance ceases to be available upon commercially reasonable terms, the Supplier shall immediately notify Transnet in writing of such termination and/or unavailability, whereafter either the Supplier or Transnet may terminate this Agreement on giving the other Party not less than 30 [thirty] calendar days prior written notice to that effect.

32 LIMITATION OF LIABILITY

- 32.1 The Supplier's liability under this clause 325 shall be in addition to any warranty or condition of any kind, express or implied by law or otherwise, relating to the Services or ancillary Services, including the quality of the Services or ancillary Services or any materials delivered pursuant to this Agreement.
- 32.2 Neither Party excludes or limits liability to the other Party for:
- a) death or personal injury caused by its negligence, [including its employees', agents' or Subcontractors' negligence]; or
 - b) fraud or theft.
- 32.3 The Supplier shall indemnify and keep Transnet indemnified from and against liability for damage to any Transnet property [whether tangible or intangible] or any other loss, costs or damage suffered by Transnet to the extent that it results from any act of or omission by the Supplier or its Personnel in connection with this Agreement. The Supplier's liability arising out of this clause 32.3 shall be limited to direct damages.
- 32.4 Subject always to clauses 32.1 and 32.2 above, the liability of either the Supplier or Transnet under or in connection with this Agreement, whether for negligence, misrepresentation, breach of contract or otherwise, for direct loss or damage arising out of each Default or series of related Defaults shall not exceed 100% [one hundred per cent] of the Fees paid under the schedule or Work Order to which the Default(s) relates.
- 32.5 Subject to clauses 32.1 to 32.4 above, in no event shall either Party be liable to the other for indirect or consequential loss or damage or including indirect or consequential loss of profits, business, revenue, goodwill or anticipated savings of an indirect nature or loss or damage incurred by the other Party as a result of third party claims.
- 32.6 If for any reason the exclusion of liability in clause 32.5 above is void or unenforceable, either Party's total liability for all loss or damage under this Agreement shall be as provided in clause 32.3 above.
- 32.7 Nothing in this clause 325 shall be taken as limiting the liability of the Parties in respect of clauses 293 [*Confidentiality*] and 336 [*Intellectual Property Rights*].

33 INTELLECTUAL PROPERTY RIGHTS

- 33.1 **Title to Confidential Information**
- a) Transnet will retain all right, title and interest in and to its Confidential Information and Background Intellectual Property and the Supplier acknowledges that it has no claim of any nature in and to the Confidential Information and Background Intellectual Property that is

proprietary to Transnet. For the avoidance of doubt all the Supplier's Background Intellectual Property shall remain vested in the Supplier.

- b) Transnet shall grant to the Supplier an irrevocable, royalty free, non-exclusive licence to use Transnet's Background Intellectual Property only for the Permitted Purpose. This licence shall not permit the Supplier to sub-license to other parties.
- c) The Supplier shall grant to Transnet an irrevocable, royalty free, non-exclusive licence to use the Supplier's Background Intellectual Property for the Permitted Purpose. This licence shall not permit Transnet to sub-license to other parties.
- d) The Supplier shall grant Transnet access to the Supplier's Background Intellectual Property on terms which shall be *bona fide* negotiated between the Parties for the purpose of commercially exploiting the Foreground Intellectual Property, to the extent that such access is required.
- e) The above shall not pertain to any software licenses procured by the Supplier from third parties and used in the supply of the Goods/Services.

33.2 **Title to Intellectual Property**

- a) All right, title and interest in and to Foreground Intellectual Property prepared, conceived or developed by the Supplier, its researchers, agents and employees shall vest in Transnet and the Supplier acknowledges that it has no claim of any nature in and to the Foreground Intellectual Property. The Supplier shall not at any time during or after the termination or cancellation of this Agreement dispute the validity or enforceability of such Foreground Intellectual Property, or cause to be done any act or anything contesting or in any way impairing or tending to impair any part of that right, title and interest to any of the Foreground Intellectual Property and shall not counsel or assist any person to do so.
- b) Transnet shall be entitled to seek protection in respect of the Foreground Intellectual Property anywhere in the world as it shall decide in its own absolute discretion and the Supplier shall reasonably assist Transnet in attaining and maintaining protection of the Foreground Intellectual Property.
- c) Where the Foreground Intellectual Property was created by the Supplier or its researchers, agents and employees and where Transnet elects not to exercise its option to seek protection or decides to discontinue the financial support of the prosecution or maintenance of any such protection, Transnet shall notify the Supplier who shall have the right of first refusal to file or continue prosecution or maintain any such applications and to maintain any protection issuing on the Foreground Intellectual Property.
- d) No consideration shall be paid by Transnet to the Supplier for the assignment of any Foreground Intellectual Property from the Supplier to Transnet, over and above the sums payable in terms of this Agreement. The Supplier undertakes to sign all documents and do all things as may be necessary to effect, record and perfect the assignment of the Foreground Intellectual Property to Transnet.
- e) Subject to anything contrary contained in this Agreement and/or the prior written consent of Transnet [which consent shall not be unreasonably withheld], the Supplier shall under no circumstances be entitled as of right, or to claim the right, to use Transnet's Background Intellectual Property and/or Foreground Intellectual Property.

33.3 **Title to Improvements**

Any improvements, developments, adaptations and/or modifications to the Foreground Intellectual Property, and any and all new inventions or discoveries, based on or resulting from the use of Transnet's Background Intellectual Property and/or Confidential Information shall be exclusively owned by Transnet. The Supplier shall disclose promptly to Transnet all such improvements, developments, adaptations and/or modifications, inventions or discoveries. The Supplier hereby undertakes to sign all documents and do all things as may be necessary to effect, record and perfect the assignment of such improvements, developments, adaptations and/or modifications, inventions or discoveries to Transnet and the Supplier shall reasonably assist Transnet in attaining, maintaining or documenting ownership and/or protection of the improved Foreground Intellectual Property.

33.4 **Unauthorised Use of Confidential Information**

The Supplier shall not authorise any party to act on or use in any way any Confidential Information belonging to Transnet whether or not such party is aware of such Confidential Information, and shall promptly notify Transnet of the information if it becomes aware of any party so acting, and shall provide Transnet the information with such assistance as Transnet reasonably requires, at Transnet's cost and expense, to prevent such third party from so acting.

33.5 **Unauthorised Use of Intellectual Property**

- a) The Supplier agrees to notify Transnet in writing of any conflicting uses of, and applications of registrations of Patents, Designs and Trade Marks or any act of infringement, unfair competition or passing off involving the Intellectual Property of Transnet of which the Supplier acquires knowledge and Transnet shall have the right, as its own option, to proceed against any party infringing its Intellectual Property.
- b) It shall be within the sole and absolute discretion of Transnet to determine what steps shall be taken against the infringer and the Supplier shall co-operate fully with Transnet, at Transnet's cost, in whatever measure including legal action to bring any infringement of illegal use to an end.
- c) The Supplier shall cooperate to provide Transnet promptly with all relevant ascertainable facts.
- d) If proceedings are commenced by Transnet alone, Transnet shall be responsible for all expenses but shall be entitled to all damages or other awards arising out of such proceedings. If proceedings are commenced by both Parties, both Parties will be responsible for the expenses and both Parties shall be entitled to damages or other awards arising out of proceedings.

34 NON-WAIVER

- 34.1 Failure or neglect by either Party, at any time, to enforce any of the provisions of this Agreement, shall not in any manner be construed to be a waiver of any of that Party's rights in that regard and in terms of this Agreement.
- 34.2 Such failure or neglect shall not in any manner affect the continued, unaltered validity of this Agreement, or prejudice the right of that Party to institute subsequent action.

35 PARTIAL INVALIDITY

If any provision of this Agreement shall be held to be invalid, illegal or unenforceable, or shall be required to be modified, the validity, legality and enforceability of the remaining provisions shall not be affected thereby.

36 DISPUTE RESOLUTION

- 36.1 Should any dispute of whatsoever nature arise between the Parties concerning this Agreement, the Parties shall try to resolve the dispute by negotiation within 10 [ten] Business Days of such dispute arising.
- 36.2 If the dispute has not been resolved by such negotiation, either of the Parties may refer the dispute to AFSA and notify the other Party accordingly, which proceedings shall be held in Johannesburg.
- 36.3 Such dispute shall be finally resolved in accordance with the rules of AFSA by an arbitrator or arbitrators appointed by AFSA.
- 36.4 This clause constitutes an irrevocable consent by the Parties to any proceedings in terms hereof, and neither of the Parties shall be entitled to withdraw from the provisions of this clause or claim at any such proceedings that it is not bound by this clause 36.
- 36.5 This clause 369 is severable from the rest of this Agreement and shall remain in effect even if this Agreement is terminated for any reason.
- 36.6 This clause 369 shall not preclude either Party from seeking urgent relief in a court of appropriate jurisdiction, where grounds for urgency exist.

37 ADDRESSES FOR NOTICES

37.1 The Parties to this Agreement select the physical addresses and fax numbers, as detailed hereafter, as their respective addresses for giving or sending any notice provided for or required in terms of this Agreement, provided that either Party shall be entitled to substitute such other address or fax number, as may be, by written notice to the other:

a) **Transnet**

(i) For legal notices:
.....
.....
Fax No.
Attention: Group Legal Department

(ii) For commercial notices:
.....
.....
Fax No.
Attention:

b) **The Supplier**

(i) For legal notices:
.....

.....

Fax No.

Attention:

(ii) For commercial notices:

.....

.....

.....

Fax No.

Attention:

37.2 Any notice shall be addressed to a Party at its physical address, or delivered by hand, or sent by fax or email.

37.3 Any notice shall be deemed to have been given:

- a) if hand delivered, on the day of delivery;
- b) if faxed, on the date and time of sending of such fax, as evidenced by a fax confirmation printout, provided that such notice shall be confirmed by prepaid registered post on the date of dispatch of such fax, or, should no postal facilities be available on that date, on the next Business Day; or
- c) if sent by email, on the date and time received, provided that such notice shall be confirmed by prepaid registered post on the date of dispatch of such email, or, should no postal facilities be available on that date, on the next Business Day.

38 WHOLE AND ONLY AGREEMENT

38.1 The Parties hereby confirm that this Agreement constitutes the whole and only agreement between them with regard to the subject matter of this Agreement.

38.2 The Parties hereby confirm that this Agreement replaces all other agreements which exist or may have existed in any form whatsoever between them, with regard to the subject matter dealt with in this Agreement, any annexures appended hereto and the Schedule of Requirements/Work Order.

39 AMENDMENT AND CHANGE CONTROL

39.1 Any amendment or change of any nature made to this Agreement and the Schedule of Requirements thereof shall only be valid if it is in writing, signed by both Parties and added to this Agreement as an addendum hereto. In this regard a Change Notice must first be defined and issued by the requesting Party. A Change Notice Response must then be issued by responding Party. A formal approval of the Change Request will then trigger the issue of the addendum to this Agreement.

39.2 In the event the Parties cannot agree upon changes, the Parties shall in good faith seek to agree any proposed changes using the dispute resolution procedures in clause 369 *[Dispute Resolution]*.

40 GENERAL

40.1 **Governing Law**

This Agreement is exclusively governed by and construed in accordance with the laws of the Republic of South Africa and is subject to the jurisdiction of the courts of the Republic of South Africa.

40.2 **Change of Law**

In this Agreement, unless the context otherwise requires, references to a statutory provision include references to that statutory provision as from time to time amended, extended or re-enacted and any regulations made under it, provided that in the event that the amendment, extension or re-enactment of any statutory provision or introduction of any new statutory provision has a material impact on the obligations of either Party, the Parties will negotiate in good faith to agree such amendments to this Agreement as may be appropriate in the circumstances. If, within a reasonable period of time, the Supplier and Transnet cannot reach agreement on the nature of the changes required or on modification of Prices, delivery schedules, warranties, or other terms and conditions, either Party may seek to have the matter determined in accordance with clause 369 [*Dispute Resolution*] above.

40.3 **Counterparts**

This Agreement may be signed in any number of counterparts, all of which taken together shall constitute one and the same instrument. Either Party may enter into this Agreement by signing any such counterpart.

41 DATABASE OF RESTRICTED SUPPLIER

The process of restriction is used to exclude a company/person from conducting future business with Transnet and other organs of state for a specified period. No Bid shall be awarded to a Bidder whose name (or any of its members, directors, partners or trustees) appear on the Register of Tender Defaulters kept by National Treasury, or who have been placed on National Treasury's List of Restricted Suppliers. Transnet reserves the right to withdraw an award, or cancel a contract concluded with a Bidder should it be established, at any time, that a bidder has been restricted with National Treasury by another government institution.

Thus signed by the Parties and witnessed on the following dates and at the following places:

For and on behalf of TRANSNET SOC LTD duly authorised hereto	For and on behalf of duly authorised hereto
Name:	Name:
Position:	Position:
Signature:	Signature:
Date:	Date:
Place:	Place:

AS WITNESS: Name:	AS WITNESS: Name:
Signature:	Signature:

AS WITNESS: Name:	AS WITNESS: Name:
Signature:	Signature:

GENERAL BID CONDITIONS

TABLE OF CONTENTS

1 DEFINITIONS3

2 GENERAL3

3 SUBMITTING OF BID DOCUMENTS.....3

4 USE OF BID FORMS3

5 BID FEES4

6 VALIDITY PERIOD.....4

7 SITE VISITS / BRIEFING SESSIONS4

8 CLARIFICATION BEFORE THE CLOSING DATE4

9 COMMUNICATION AFTER THE CLOSING DATE4

10 UNAUTHORISED COMMUNICATION ABOUT BIDS.....4

11 RETURNABLE DOCUMENTS4

12 DEFAULTS BY RESPONDENTS4

13 CURRENCY5

14 PRICES SUBJECT TO CONFIRMATION5

15 ALTERATIONS MADE BY THE RESPONDENT TO BID PRICES5

16 EXCHANGE AND REMITTANCE.....5

17 ACCEPTANCE OF BID.....6

18 NOTICE TO UNSUCCESSFUL RESPONDENTS.....6

19 TERMS AND CONDITIONS OF CONTRACT6

20 CONTRACT DOCUMENTS6

21 LAW GOVERNING CONTRACT.....6

22 IDENTIFICATION7

23 RESPONDENT'S SAMPLES7

24 SECURITIES.....7

25 PRICE AND DELIVERY BASIS FOR GOODS7

26 EXPORT LICENCE8

27 QUALITY OF MATERIAL8

28 VALUE-ADDED TAX8

29 IMPORTANT NOTICE TO RESPONDENTS REGARDING PAYMENT8

30 CONTRACT QUANTITIES AND DELIVERY REQUIREMENTS9

31 PLANS, DRAWINGS, DIAGRAMS, SPECIFICATIONS AND DOCUMENTS10

32 BIDS BY OR ON BEHALF OF FOREIGN RESPONDENTS.....10

33 DATABASE OF RESTRICTED SUPPLIERS11

34 CONFLICT WITH ISSUED RFX DOCUMENT11

1 DEFINITIONS

Where the following words or phrases are used in this Agreement, such words or phrases shall have the meaning assigned thereto in this clause, except where the context clearly requires otherwise:

- 1.1 **Bid** shall mean a Respondent's tendered response / proposal to a Transnet RFP or RFQ;
- 1.2 **Bid Document(s)** shall mean a reference to a Request for Proposal or Request for Quotation;
- 1.3 **Business Day** shall mean any day other than a Saturday, Sunday or public holiday;
- 1.4 **Goods** shall mean the goods required by Transnet as specified in its Bid Document;
- 1.5 **Parties** shall mean Transnet and the Respondents to a Bid Document;
- 1.6 **Respondent(s)** shall mean a respondent/bidder to a Bid Document;
- 1.7 **RFP** shall mean Request for Proposal;
- 1.8 **RFQ** shall mean Request for Quotation;
- 1.9 **RFX** shall mean RFP or RFQ, as the case may be;
- 1.10 **Services** shall mean the services required by Transnet as specified in its Bid Document;
- 1.11 **Supplier** shall mean the successful Respondent;
- 1.12 **Tax Invoice** shall mean the document as required by Section 20 of the Value-Added Tax Act, 89 of 1991, as may be amended from time to time;
- 1.13 **Transnet** shall mean Transnet SOC Ltd, a State Owned Company; and
- 1.14 **VAT** shall mean Value-Added Tax in terms of the Value-Added Tax Act, 89 of 1991, as may be amended from time to time.

2 GENERAL

All Bid Documents and subsequent contracts and orders shall be subject to the following general conditions as laid down by Transnet and are to be strictly adhered to by any Respondent to this RFX.

3 SUBMITTING OF BID DOCUMENTS

- 3.1 A Bid, which shall hereinafter include reference to an RFP or RFQ, shall be submitted to Transnet no later than the closing date and time specified in accordance with the directions issued in the Bid Documents. Late Bids will not be considered.
- 3.2 The Bid Documents must be completed in their entirety and Respondents are required to complete and submit their Bid submissions by uploading them into the system against each tender selected. The bidder guide can be found on the Transnet Portal transnetetenders.azurewebsites.net.

4 USE OF BID FORMS

- 4.1 Where special forms and/or formats are issued by Transnet for the submission of Bids, Respondents are required to submit their Bids by completion of the appropriate sections on such official forms and/or formats and not in other forms and/or formats or documents bearing their own terms and conditions of contract. Non-compliance with this condition may result in the rejection of a Bid.
- 4.2 Respondents must note that the original Bid forms and/or formats must be completed for submission.
- 4.3 Only if insufficient space has been allocated to a particular response may a Respondent submit additional information under separate cover using the Company's letterhead. This must be duly cross-referenced in the RFX.

5 BID FEES

A bid fee is not applicable. The Bid Documents may be downloaded directly from National Treasury's e-Tender Publication Portal at www.etenders.gov.za and may also be downloaded from the Transnet website at www.transnet.net free of charge.

6 VALIDITY PERIOD

6.1 The Respondents must hold their Bid valid for acceptance by Transnet at any time within the requested validity period after the closing date of the bid.

6.2 Respondents may be requested to extend their validity period for a specified additional period. In such instances, Respondents will not be allowed to change any aspect of their Bid, unless they are able to demonstrate that the proposed change/s is as a direct and unavoidable consequence of Transnet's extension of the validity period.

7 SITE VISITS / BRIEFING SESSIONS

Respondents may be requested to attend a site visit or briefing session where it is necessary to view the site in order to prepare their Bids, or where Transnet deems it necessary to provide Respondents with further information to allow them to complete their Bids properly. Where such visits or sessions are indicated as compulsory in the RFX Document, Respondents are obliged to attend these meetings as failure to do so will result in their disqualification.

8 CLARIFICATION BEFORE THE CLOSING DATE

Should clarification be required on any aspect of the Bid before the closing date, the Respondent must upload questions onto the Transnet e-Tender Submission Portal or direct such queries to the contact person listed in the RFX Document in the stipulated manner.

9 COMMUNICATION AFTER THE CLOSING DATE

After the closing date of a Bid (i.e. during the evaluation period) the Respondent may only communicate with the contact person listed in the RFX Document.

10 UNAUTHORISED COMMUNICATION ABOUT BIDS

Respondents may at any time communicate with the contact person listed in the RFX Document on any matter relating to its Bid but, in the absence of written authority from the delegated individual (BEC chairperson), no communication on a question affecting the subject of a Bid shall take place between Respondents or other potential Supplier or any member of the Bid Adjudication Committee or official of Transnet during the period between the closing date for the receipt of the Bid and the date of the notification of the successful Respondent(s). A Bid, in respect of which any such unauthorised communication has occurred, may be disqualified.

11 RETURNABLE DOCUMENTS

All returnable documents listed in the RFX Documents must be submitted with Respondent's Bid. Failure to submit mandatory returnable schedules / documents will result in disqualification. Failure to submit other schedules / documents may result in disqualification.

12 DEFAULTS BY RESPONDENTS

If the Respondent, after it has been notified of the acceptance of its Bid fails to:

- 12.1 enter into a formal contract when called upon to do so within such period as Transnet may specify; or
- 12.2 accept an order in terms of the Bid;
- 12.3 furnish satisfactory security when called upon to do so for the fulfilment of the contract; or
- 12.4 comply with any condition imposed by Transnet,

Transnet may, in any such case, without prejudice to any other legal remedy which it may have, proceed to accept any other Bid or, if it is necessary to do so, call for Bids afresh, and may recover from the defaulting Respondent any additional expense incurred by Transnet in calling for new offers or in accepting a less favourable offer.

13 CURRENCY

All monetary amounts referred to in a Bid response must be in Rand, the currency of the Republic of South Africa [**ZAR**], save to the extent specifically permitted in the RFP.

14 PRICES SUBJECT TO CONFIRMATION

Prices which are quoted subject to confirmation will not be considered.

15 ALTERATIONS MADE BY THE RESPONDENT TO BID PRICES

All alterations made by the Respondent to its Bid price(s) prior to the submission of its Bid Documents must be done by deleting the incorrect figures and words where required and by inserting the correct figures and words against the items concerned. All such alterations must be initialled by the person who signs the Bid Documents. Failure to observe this requirement may result in the particular item(s) concerned being excluded in the matter of the award of the business.

16 EXCHANGE AND REMITTANCE

- 16.1 The Respondent should note that where the whole or a portion of the contract or order value is to be remitted overseas, Transnet shall, if requested to do so by the Supplier, effect payment overseas directly to the foreign principal or manufacturer of such percentage of the contract or order value as may be stipulated by the Respondent in its Bid Documents.
- 16.2 It is Transnet's preference to enter into Rand-based agreements. Transnet would request, therefore, that the Respondent give favourable consideration to obtaining forward exchange cover on the foreign currency portion of the Agreement at a cost that is acceptable to Transnet to protect itself against any currency rate fluctuation risks for the duration of any resulting contract or order.
- 16.3 The Respondent who desires to avail itself of the aforementioned facility must at the time of bidding furnish the information called for in the Exchange and Remittance section of the Bid Documents and also furnish full details of the principals or manufacturer to whom payment is to be made.
- 16.4 The South African Reserve Bank's approval is required before any foreign currency payments can be made to or on behalf of Respondents.
- 16.5 Transnet will not recognise any claim for adjustment of the order and/or contract price if the increase in price arises after the date on which the Goods were to be delivered, as set out in the order and/or contract, or any subsequent agreement between the parties.
- 16.6 Transnet reserves the right to request a pro-forma invoice/tax invoice in order to ensure compliance with the contract and Value-Added Tax Act no. 89 of 1991 [VAT Act].

17 ACCEPTANCE OF BID

17.1 Upon the acceptance of a Bid by Transnet, the parties shall be bound by these General Bid Conditions and any contractual terms and/or any schedule of "Special Conditions" or otherwise which form part of the Bid Documents.

17.2 Where the Respondent has been informed by Transnet of the acceptance of its Bid, an email communication that has been successfully sent to the Respondent shall be regarded as proof of delivery to the Respondent 1 day after the date of submission.

18 NOTICE TO UNSUCCESSFUL RESPONDENTS

18.1 Unsuccessful Respondents shall be advised in writing that their Bids have not been accepted as soon as possible after the closing date of the Bid. On award of business to the successful Respondent all unsuccessful Respondents must be informed of the name of the successful Respondent and of the reason as to why their Bids had been unsuccessful.

19 TERMS AND CONDITIONS OF CONTRACT

19.1 The Supplier shall adhere to the Terms and Conditions of Contract issued with the Bid Documents, together with any schedule of "Special Conditions" or otherwise which form part of the Bid Documents.

19.2 Should the Respondent find any conditions unacceptable, it should indicate which conditions are unacceptable and offer amendments/ alternatives by written submission on a company letterhead. Any such submission shall be subject to review by Transnet's Legal Counsel who shall determine whether the proposed amendments /alternative(s) are acceptable or otherwise, as the case may be. Respondents will be afforded an opportunity to withdraw an unacceptable deviation, failing which the respondent will be disqualified.

20 CONTRACT DOCUMENTS

20.1 The contract documents will comprise these General Bid Conditions, the Terms and Conditions of Contract and any schedule of "Special Conditions" which form part of the Bid Documents.

20.2 The abovementioned documents together with the Respondent's Bid response will constitute the contract between the parties upon receipt by the Respondent of Transnet's letter of acceptance, subject to all additional amendments and/or special conditions thereto as agreed to by the parties.

20.3 Should Transnet inform the Respondent that a formal contract will be signed, the abovementioned documents together with the Respondent's Bid response [and, if any, its covering letter and any subsequent exchange of correspondence] as well as Transnet's Letter of Acceptance, shall constitute a binding contract until the final contract is signed.

21 LAW GOVERNING CONTRACT

The law of the Republic of South Africa shall govern the contract created by the acceptance of a Bid. The *domicilium citandi et executandi* shall be a place in the Republic of South Africa to be specified by the Respondent in its Bid at which all legal documents may be served on the Respondent who shall agree to submit to the jurisdiction of the courts of the Republic of South Africa. A foreign Respondent shall, therefore, state in its Bid the name of its authorised representative in the Republic of South Africa who is empowered to sign any contract which may be entered into in the event of its Bid being accepted and to act on its behalf in all matters relating to the contract.

22 IDENTIFICATION

If the Respondent is a company, the full names of the directors shall be stated in the Bid. If the Respondent is a close corporation, the full names of the members shall be stated in the Bid. If the Respondent is a partnership or an individual trading under a trade name, the full names of the partners or of such individual, as the case may be, shall be furnished.

23 RESPONDENT'S SAMPLES

- 23.1 If samples are required from Respondents, such samples shall be suitably marked with the Respondent's name and address, the Bid number and the Bid item number and must be despatched in time to reach the addressee as stipulated in the Bid Documents on or before the closing date of the Bid. Failure to submit samples by the due date may result in the rejection of a Bid.
- 23.2 Transnet reserves the right to retain samples furnished by Respondents in compliance with Bid conditions.
- 23.3 Payment will not be made for a successful Respondent's samples that may be retained by Transnet for the purpose of checking the quality and workmanship of Goods delivered in execution of a contract.
- 23.4 If Transnet does not wish to retain unsuccessful Respondents' samples and the Respondents require their return, such samples may be collected by the Respondents at their own risk and cost.

24 SECURITIES

- 24.1 The successful Respondent, when called upon to do so, shall provide security to the satisfaction of Transnet for the due fulfilment of a contract or order. Such security shall be in the form of a Deed of Suretyship [Deed of Suretyship] furnished by an approved bank, building society, insurance or guarantee corporation carrying on business in South Africa.
- 24.2 The security may be applied in whole or part at the discretion of Transnet to make good any loss or damage which Transnet may incur in consequence of a breach of the contract or any part thereof.
- 24.3 Such security, if required, shall be an amount which will be stipulated in the Bid Documents.
- 24.4 For the purpose of clause 24.124.1 above, Transnet will supply a Deed of Suretyship form to the successful Respondent for completion and no guarantee in any other form will be accepted. A copy of such form will be supplied to Respondents on request. For this purpose a Deed of Suretyship form will be provided which shall be completed and returned to Transnet or a designated official by the successful Respondent within 30 [thirty] calendar days from the date of the letter of acceptance. No payment will be made until the form, duly completed, is delivered to Transnet. Failure to return the Deed of Suretyship within the prescribed time shall, save where prior extension has been granted, entitle Transnet without notice to the Supplier to cancel the contract with immediate effect.
- 24.5 Additional costs incurred by Transnet necessitated by reason of default on the part of the Supplier in relation to the conditions of this clause 244 will be for the account of the Supplier.

25 PRICE AND DELIVERY BASIS FOR GOODS

- 25.1 Unless otherwise specified in the Bid Documents, the prices quoted for Goods must be on a Delivered Duty Paid [latest ICC Incoterms] price basis in accordance with the terms and at the delivery point or points specified in Transnet's Bid Documents. Bids for supply on any other basis of delivery are liable to disqualification. The lead time for delivery stated by the Respondent must be inclusive of all non-

working days or holidays, and of periods occupied in stocktaking or in effecting repairs to or overhauling plant, which would ordinarily occur within the delivery period given by the Respondent.

25.2 Respondents must furnish their Bid prices in the Price Schedule of the Bid Documents on the following basis:

- a) Local Supplies - Prices for Goods to be manufactured, produced or assembled in the Republic of South Africa, or imported supplies held in South Africa, to be quoted on a Delivered RSA named destination basis.
- b) Imported Supplies - Prices for Goods to be imported from all sources to be quoted on a Delivered Duty Paid [latest ICC Incoterms] basis, to end destination in South Africa, unless otherwise specified in the Bid Price Schedule.

26 EXPORT LICENCE

The award of a Bid for Goods to be imported may be subject to the issue of an export licence in the country of origin or supply. If required, the Supplier's manufacturer or forwarding agent shall be required to apply for such licence.

27 QUALITY OF MATERIAL

Unless otherwise stipulated, the Goods offered shall be NEW i.e. in unused condition, neither second-hand nor reconditioned.

28 VALUE-ADDED TAX

28.1 In respect of local supplies, i.e. Goods to be manufactured, produced or assembled in the Republic of South Africa, or imported supplies held or already in transit to South Africa, the prices quoted by the Respondent are to be inclusive of VAT which must be shown separately at the standard rate on the Tax Invoice.

28.2 In respect of foreign Services rendered:

- a) the invoicing by a South African supplier on behalf of its foreign principal rendering such Service represents a Service rendered by the principal; and
- b) the Supplier's Tax Invoice(s) for the local portion only [i.e. the "commission" for the Services rendered locally] must show the VAT separately.

29 IMPORTANT NOTICE TO RESPONDENTS REGARDING PAYMENT

29.1 Method of Payment

- a) The attention of the Respondent is directed to the Terms and Conditions of Contract which set out the conditions of payment on which Bid price(s) shall be based.
- b) However, in addition to the foregoing the Respondent is invited to submit offers based on alternative methods of payment and/or financing proposals.
- c) The Respondent is required to give full particulars of the terms that will be applicable to its alternative offer(s) and the financial merits thereof will be evaluated and taken into consideration when the Bid is adjudicated.
- d) The Respondent must, therefore, in the first instance, tender strictly in accordance with clause 29.1 (a) above. Failure to comply with clause 29.1 (a) above may preclude a Bid from further consideration.

NOTE: The successful Respondent [the **Supplier**] shall, where applicable, be required to furnish a guarantee covering any advance payments.

29.2 Conditional Discount

Respondents offering prices which are subject to a conditional discount applicable for payment within a specific period are to note that the conditional period will be calculated as from the date of receipt by Transnet of the Supplier's month-end statement reflecting the relevant Tax Invoice(s) for payment purposes, provided the conditions of the order or contract have been fulfilled and the Tax Invoice is correct in all respects as referred to in the contract or order. Incomplete and/or incorrect Tax Invoices shall be returned and the conditional period will be recalculated from the date of receipt of the correct documentation.

30 CONTRACT QUANTITIES AND DELIVERY REQUIREMENTS

30.1 Contract Quantities

- a) It must be clearly understood that although Transnet does not bind itself to purchase a definitive quantity under any contract which may be entered into pursuant to this Bid, the successful Respondent nevertheless undertakes to supply against the contract such quantities as may be ordered against the contract, which orders are posted or delivered by hand or transmitted electronically on or before the expiry date of such contract.
- b) It is furthermore a condition that Transnet will not accept liability for any material/stocks specially ordered or carried by the Respondent with a view to meeting the requirements under any such contract.
- c) The estimated planned quantities likely to be ordered by Transnet per annum are furnished in relevant section of the Bid Documents. For avoidance of doubt the estimated quantities are estimates and Transnet reserves the right to order only those quantities sufficient for its operational requirements.

30.2 Delivery Period

a) Period Contracts and Fixed Quantity Requirements

It will be a condition of any resulting contract/order that the delivery period embodied therein will be governed by the provisions of the Terms and Conditions of Contract.

b) Progress Reports

The Supplier may be required to submit periodical progress reports with regard to the delivery of the Goods

c) Emergency Demands as and when required

If, due to unforeseen circumstances, supplies of the Goods covered by the Bid are required at short notice for immediate delivery, the Supplier will be given first right of refusal for such business. If it is unable to meet the desired critical delivery period, Transnet reserves the right to purchase such supplies as may be required to meet the emergency outside the contract if immediate delivery can be offered from any other source. The *Total or Partial Failure to Perform the Scope of Supply* section in the Terms and Conditions of Contract will not be applicable in these circumstances.

31 PLANS, DRAWINGS, DIAGRAMS, SPECIFICATIONS AND DOCUMENTS

31.1 Copyright

Copyright in plans, drawings, diagrams, specifications and documents compiled by the Supplier for the purpose of contract work shall be governed by the Intellectual Property Rights section in the Terms and Conditions of Contract.

31.2 Drawings and specifications

In addition to what may be stated in any Bid Document, the Respondent should note that, unless notified to the contrary by Transnet or a designated official by means of an official amendment to the Bid Documents, it is required to tender for Goods strictly in accordance with the drawings and/or specifications supplied by Transnet, notwithstanding that it may be aware that alterations or amendments to such drawings or specifications are contemplated by Transnet.

31.3 Respondent's drawings

Drawings required to be submitted by the Respondent must be furnished before the closing time and date of the Bid. The non-receipt of such drawings by the appointed time may disqualify the Bid.

31.4 Foreign specifications

The Respondent quoting for Goods in accordance with foreign specifications, other than British and American standards, is to submit translated copies of such specifications with the Bid. In the event of any departures or variations between the foreign specification(s) quoted in the Bid Documents, full details regarding such departures or variations must be furnished by the Respondent in a covering letter attached to the Bid. Non-compliance with this condition may result in disqualification.

32 BIDS BY OR ON BEHALF OF FOREIGN RESPONDENTS

32.1 Bids submitted by foreign principals may be forwarded directly by the principals or by its South African representative or agent to the designated official of Transnet according to whichever officer is specified in the Bid Documents.

32.2 In the case of a representative or agent, written proof must be submitted to the effect that such representative or agent has been duly authorised to act in that capacity by the principal. Failure to submit such authorisation by the representative or agent shall disqualify the Bid.

32.3 When legally authorised to prepare and submit Bids on behalf of their principals not domiciled in the Republic of South Africa, representatives or agents must compile the Bids in the names of such principals and sign them on behalf of the latter.

32.4 South African representatives or agents of a successful foreign Respondent must when so required enter into a formal contract in the name of their principals and must sign such contract on behalf of the latter. In every such case a legal Power of Attorney from their principals must be furnished to Transnet by the South African representative or agents authorising them to enter into and sign such contract.

a) Such Power of Attorney must comply with Rule 63 (Authentication of documents executed outside the Republic for use within the Republic) of the Uniform Rules of Court: Rules regulating the conduct of the proceedings of the several provincial and local divisions of the Supreme Court of South Africa.

b) The Power of Attorney must be signed by the principal under the same title as used in the Bid Documents.

- c) If a Power of Attorney held by the South African representative or agent includes matters of a general nature besides provision for the entering into and signing of a contract with Transnet, a certified copy thereof should be furnished.
 - d) The Power of Attorney must authorise the South African representative or agent to choose the *domicilium citandi et executandi*.
- 32.5 If payment is to be made in South Africa, the foreign Supplier [i.e. the principal, or its South African agent or representative], must notify Transnet in writing whether, for payment by electronic funds transfer [EFT]:
- a) funds are to be transferred to the credit of the foreign Supplier's account at a bank in South Africa, in which case the name and branch of such bank shall be furnished; or
 - b) funds are to be transferred to the credit of its South African agent or representative, in which case the name and branch of such bank shall be furnished.
- 32.6 The attention of the Respondent is directed to clause 24 above [Securities] regarding the provision of security for the fulfilment of contracts and orders and the manner and form in which such security is to be furnished.

33 DATABASE OF RESTRICTED SUPPLIERS

The process of restriction is used to exclude a company/person from conducting future business with Transnet and other organs of state for a specified period. No Bid shall be awarded to a Bidder whose name (or any of its members, directors, partners or trustees) appear on the Register of Tender Defaulters kept by National Treasury, or who have been placed on National Treasury's List of Restricted Suppliers. Transnet reserves the right to withdraw an award, or cancel a contract concluded with a Bidder should it be established, at any time, that a bidder has been restricted with National Treasury by another government institution.

34 CONFLICT WITH ISSUED RFX DOCUMENT

- 34.1 Should a conflict arise between these General Bid Conditions and the issued RFX document, the conditions stated in the RFX document shall prevail.

oooOOOooo



Important Note: All potential bidders must read this document and certify in the RFX Declaration Form that they have acquainted themselves with, and agree with the content. The contract with the successful bidder will automatically incorporate this Integrity Pact as part of the final concluded contract.

INTEGRITY PACT

Between

TRANSNET SOC LTD

Registration Number: 1990/000900/30

("Transnet")

And The Bidder / Supplier/ Service Provider / Contractor (hereinafter referred to as the "Bidder / Supplier")

PREAMBLE

Transnet values full compliance with all relevant laws and regulations, ethical standards and the principles of economical use of resources, fairness and transparency in its relations with its Bidders / Suppliers.

In order to achieve these goals, Transnet and the Bidder / Supplier hereby enter into this agreement hereinafter referred to as the "Integrity Pact" which will form part of the Bidder's / Supplier's application for registration with Transnet as a vendor.

The general purpose of this Integrity Pact is to agree on avoiding all forms of dishonesty, fraud and corruption by following a system that is fair, transparent and free from any undue influence prior to, during and subsequent to the currency of any procurement and / or reverse logistics event and any further contract to be entered into between the Parties, relating to such event.

All Bidders / Suppliers will be required to sign and comply with undertakings contained in this Integrity Pact, should they want to be registered as a Transnet vendor.

1 OBJECTIVES

- 1.1 Transnet and the Bidder / Supplier agree to enter into this Integrity Pact, to avoid all forms of dishonesty, fraud and corruption including practices that are anti-competitive in nature, negotiations made in bad faith and under-pricing by following a system that is fair, transparent and free from any influence / unprejudiced dealings prior to, during and subsequent to the currency of the contract to be entered into with a view to:
 - a) Enable Transnet to obtain the desired contract at a reasonable and competitive price in conformity to the defined specifications of the works, goods and services; and
 - b) Enable Bidders / Suppliers to abstain from bribing or participating in any corrupt practice in order to secure the contract.

2 COMMITMENTS OF TRANSNET

Transnet commits to take all measures necessary to prevent dishonesty, fraud and corruption and to observe the following principles:

- 2.1 Transnet hereby undertakes that no employee of Transnet connected directly or indirectly with the sourcing event and ensuing contract, will demand, take a promise for or accept directly or through intermediaries any bribe, consideration, gift, reward, favour or any material or immaterial benefit or any other advantage from the Bidder, either for themselves or for any person, organisation or third party related to the contract in exchange for an advantage in the bidding process, bid evaluation, contracting or implementation process related to any contract.
- 2.2 Transnet will, during the registration and bidding process treat all Bidders / Suppliers with equity, transparency and fairness. Transnet will in particular, before and during the registration process, provide to all Bidders / Suppliers the same information and will not provide to any Bidders / Suppliers confidential / additional information through which the Bidders / Suppliers could obtain an advantage in relation to any bidding process.
- 2.3 Transnet further confirms that its employees will not favour any prospective bidder in any form that could afford an undue advantage to a particular bidder during the tendering stage, and will further treat all Bidders / Supplier participating in the bidding process in a fair manner.
- 2.4 Transnet will exclude from the bidding process such employees who have any personal interest in the Bidders / Suppliers participating in the bidding process.

3 OBLIGATIONS OF THE BIDDER / SUPPLIER

- 3.1 Transnet has a '**Zero Gifts**' Policy. No employee is allowed to accept gifts, favours or benefits.
- a) Transnet officials and employees **shall not** solicit, give or accept, or from agreeing to solicit, give, accept or receive directly or indirectly, any gift, gratuity, favour, entertainment, loan, or anything of monetary value, from any person or juridical entities in the course of official duties or in connection with any operation being managed by, or any transaction which may be affected by the functions of their office.
 - b) Transnet officials and employees **shall not** solicit or accept gifts of any kind, from vendors, suppliers, customers, potential employees, potential vendors, and suppliers, or any other individual or organisation irrespective of the value.
 - c) Under **no circumstances** should gifts, business courtesies or hospitality packages be accepted from or given to prospective suppliers participating in a tender process at the respective employee's Operating Division, regardless of retail value.
 - d) Gratuities, bribes or kickbacks of any kind must never be solicited, accepted or offered, either directly or indirectly. This includes money, loans, equity, special privileges, personal favours, benefit or services. Such favours will be considered to constitute corruption.
- 3.2 The Bidder / Supplier commits itself to take all measures necessary to prevent corrupt practices, unfair means and illegal activities during any stage of its bid or during any ensuing contract stage in order to secure the contract or in furtherance to secure it and in particular the Bidder / Supplier commits to the following:
- a) The Bidder / Supplier will not, directly or through any other person or firm, offer, promise or give to Transnet or to any of Transnet's employees involved in the bidding process or to any third person any material or other benefit or payment, in order to obtain in exchange an advantage during the bidding process; and
 - b) The Bidder / Supplier will not offer, directly or through intermediaries, any bribe, gift, consideration, reward, favour, any material or immaterial benefit or other advantage, commission, fees, brokerage or inducement to any employee of Transnet, connected directly or indirectly with the bidding process, or to any person, organisation or third party related to the contract in exchange for any advantage in the bidding, evaluation, contracting and implementation of the contract.
- 3.3 The Bidder / Supplier will not collude with other parties interested in the contract to preclude a competitive bid price, impair the transparency, fairness and progress of the bidding process, bid evaluation, contracting and implementation of the contract. The Bidder / Supplier further commits itself to delivering against all agreed upon conditions as stipulated within the contract.
- 3.4 The Bidder / Supplier will not enter into any illegal or dishonest agreement or understanding, whether formal or informal with other Bidders / Suppliers. This applies in particular to certifications, submissions or non-submission of documents or actions that are restrictive or to introduce cartels into the bidding process.
- 3.5 The Bidder / Supplier will not commit any criminal offence under the relevant anti-corruption laws of South Africa or any other country. Furthermore, the Bidder /Supplier will not use for illegitimate purposes or for restrictive purposes or personal gain, or pass on to others, any information provided by Transnet as part of the business relationship, regarding plans, technical proposals and business details, including information contained or transmitted electronically.
- 3.6 A Bidder / Supplier of foreign origin shall disclose the name and address of its agents or representatives in South Africa, if any, involved directly or indirectly in the registration or bidding process. Similarly, the Bidder / Supplier of South African nationality shall furnish the name and address of the foreign principals, if any, involved directly or indirectly in the registration or bidding process.
- 3.7 The Bidder / Supplier will not misrepresent facts or furnish false or forged documents or information in order to influence the bidding process to the advantage of the Bidder / Supplier or detriment of Transnet or other competitors.

- 3.8 Transnet may require the Bidder / Supplier to furnish Transnet with a copy of its code of conduct. Such code of conduct must address the compliance programme for the implementation of the code of conduct and reject the use of bribes and other dishonest and unethical conduct.
- 3.9 The Bidder / Supplier will not instigate third persons to commit offences outlined above or be an accessory to such offences.
- 3.10 The Bidder/Supplier confirms that they will uphold the ten principles of the United Nations Global Compact (UNGC) in the fields of Human Rights, Labour, Anti-Corruption and the Environment when undertaking business with Transnet as follows:
- a) Human Rights
 - Principle 1: Businesses should support and respect the protection of internationally proclaimed human rights; and
 - Principle 2: make sure that they are not complicit in human rights abuses.
 - b) Labour
 - Principle 3: Businesses should uphold the freedom of association and the effective recognition of the right to collective bargaining;
 - Principle 4: the elimination of all forms of forced and compulsory labour;
 - Principle 5: the effective abolition of child labour; and
 - Principle 6: the elimination of discrimination in respect of employment and occupation.
 - c) Environment
 - Principle 7: Businesses should support a precautionary approach to environmental challenges;
 - Principle 8: undertake initiatives to promote greater environmental responsibility; and
 - Principle 9: encourage the development and diffusion of environmentally friendly technologies.
 - d) Anti-Corruption
 - Principle 10: Businesses should work against corruption in all its forms, including extortion and bribery.

4 INDEPENDENT BIDDING

- 4.1 For the purposes of this undertaking in relation to any submitted Bid, the Bidder declares to fully understand that the word "competitor" shall include any individual or organisation, other than the Bidder, whether or not affiliated with the Bidder, who:
- a) has been requested to submit a Bid in response to this Bid invitation;
 - b) could potentially submit a Bid in response to this Bid invitation, based on their qualifications, abilities or experience; and
 - c) provides the same Goods and Services as the Bidder and/or is in the same line of business as the Bidder.
- 4.2 The Bidder has arrived at his submitted Bid independently from, and without consultation, communication, agreement or arrangement with any competitor. However communication between partners in a joint venture or consortium will not be construed as collusive bidding.
- 4.3 In particular, without limiting the generality of paragraph 4.2 above, there has been no consultation, communication, agreement or arrangement with any competitor regarding:
- a) prices;
 - b) geographical area where Goods or Services will be rendered [market allocation];
 - c) methods, factors or formulas used to calculate prices;
 - d) the intention or decision to submit or not to submit, a Bid;

- e) the submission of a Bid which does not meet the specifications and conditions of the RFP; or
 - f) bidding with the intention of not winning the Bid.
- 4.4 In addition, there have been no consultations, communications, agreements or arrangements with any competitor regarding the quality, quantity, specifications and conditions or delivery particulars of the Goods or Services to which his/her Bid relates.
- 4.5 The terms of the Bid as submitted have not been, and will not be, disclosed by the Bidder, directly or indirectly, to any competitor, prior to the date and time of the official Bid opening or of the awarding of the contract.
- 4.6 Bidders are aware that, in addition and without prejudice to any other remedy provided to combat any restrictive practices related to bids and contracts, Bids that are suspicious will be reported to the Competition Commission for investigation and possible imposition of administrative penalties in terms of section 59 of the Competition Act No 89 of 1998 and/or may be reported to the National Prosecuting Authority [**NPA**] for criminal investigation and/or may be restricted from conducting business with the public sector for a period not exceeding 10 [ten] years in terms of the Prevention and Combating of Corrupt Activities Act No 12 of 2004 or any other applicable legislation.

5 DISQUALIFICATION FROM BIDDING PROCESS

- 5.1 If the Bidder / Supplier has committed a transgression through a violation of paragraph 3 of this Integrity Pact or in any other form such as to put its reliability or credibility as a Bidder / Supplier into question, Transnet may reject the Bidder's / Supplier's application from the registration or bidding process and remove the Bidder / Supplier from its database, if already registered.
- 5.2 If the Bidder / Supplier has committed a transgression through a violation of paragraph 3, or any material violation, such as to put its reliability or credibility into question, Transnet may after following due procedures and at its own discretion also exclude the Bidder / Supplier from future bidding processes. The imposition and duration of the exclusion will be determined by the severity of the transgression. The severity will be determined by the circumstances of the case, which will include amongst others the number of transgressions, the position of the transgressors within the company hierarchy of the Bidder / Supplier and the amount of the damage. The exclusion will be imposed for up to a maximum of 10 (ten) years. However, Transnet reserves the right to impose a longer period of exclusion, depending on the gravity of the misconduct.
- 5.3 If the Bidder / Supplier can prove that it has restored the damage caused by it and has installed a suitable corruption prevention system, or taken other remedial measures as the circumstances of the case may require, Transnet may at its own discretion revoke the exclusion or suspend the imposed penalty.

6 DATABASE OF RESTRICTED SUPPLIERS

- 6.1 The process of restriction is used to exclude a company/person from conducting future business with Transnet and other organs of state for a specified period. No Bid shall be awarded to a Bidder whose name (or any of its members, directors, partners or trustees) appear on the Register of Tender Defaulters kept by National Treasury, or who have been placed on National Treasury's List of Restricted Suppliers. Transnet reserves the right to withdraw an award, or cancel a contract concluded with a Bidder should it be established, at any time, that a bidder has been restricted with National Treasury by another government institution.
- 6.2 All the stipulations on Transnet's restriction process as laid down in Transnet's Supply Chain Policy and Procurement Procedures Manual are included herein by way of reference. Below follows a condensed summary of this restriction procedure.
- 6.3 On completion of the restriction procedure, Transnet will submit the restricted entity's details (including the identity number of the individuals and registration number of the entity) to National Treasury for placement on National Treasury's Database of Restricted Suppliers for the specified period of exclusion. National

Treasury will make the final decision on whether to restrict an entity from doing business with any organ of state for a period not exceeding 10 years and place the entity concerned on the Database of Restricted Suppliers published on its official website.

- 6.4 The decision to restrict is based on one of the grounds for restriction. The standard of proof to commence the restriction process is whether a "*prima facie*" (i.e. on the face of it) case has been established.
- 6.5 Depending on the seriousness of the misconduct and the strategic importance of the Goods/Services, in addition to restricting a company/person from future business, Transnet may decide to terminate some or all existing contracts with the company/person as well.
- 6.6 A supplier or contractor to Transnet may not subcontract any portion of the contract to a restricted company.
- 6.7 Grounds for restriction include: If any person/Enterprise which has submitted a Bid, concluded a contract, or, in the capacity of agent or subcontractor, has been associated with such Bid or contract:
- a) Has, in bad faith, withdrawn such Bid after the advertised closing date and time for the receipt of Bids;
 - b) has, after being notified of the acceptance of his Bid, failed or refused to sign a contract when called upon to do so in terms of any condition forming part of the bid documents;
 - c) has carried out any contract resulting from such bid in an unsatisfactory manner or has breached any condition of the contract;
 - d) has offered, promised or given a bribe in relation to the obtaining or execution of the contract;
 - e) has acted in a fraudulent or improper manner or in bad faith towards Transnet or any Government Department or towards any public body, Enterprise or person;
 - f) has made any incorrect statement in a certificate or other communication with regard to the Local Content of his Goods or his B-BBEE status and is unable to prove to the satisfaction of Transnet that:
 - (i) he made the statement in good faith honestly believing it to be correct; and
 - (ii) before making such statement he took all reasonable steps to satisfy himself of its correctness;
 - g) has submitted false information regarding any other matter required in terms of the Preferential Procurement Regulations, 2017 issued in terms of the Preferential Procurement Policy Framework Act which will affect the evaluation of a Bid or where a Bidder has failed to declare any subcontracting arrangements;
 - h) caused Transnet damage, or to incur costs in order to meet the contractor's requirements and which could not be recovered from the contractor;
 - i) has litigated against Transnet in bad faith.

7 PREVIOUS TRANSGRESSIONS

- 7.1 The Bidder / Supplier hereby declares that no previous transgressions resulting in a serious breach of any law, including but not limited to, corruption, fraud, theft, extortion and contraventions of the Competition Act 89 of 1998, which occurred in the last 5 (five) years with any other public sector undertaking, government department or private sector company that could justify its exclusion from its registration on the Bidder's / Supplier's database or any bidding process.
- 7.2 If it is found to be that the Bidder / Supplier made an incorrect statement on this subject, the Bidder / Supplier can be rejected from the registration process or removed from the Bidder / Supplier database, if already registered, for such reason (refer to the Breach of Law Form contained in the applicable RFX document.)

8 SANCTIONS FOR VIOLATIONS

- 8.1 Transnet shall also take all or any one of the following actions, wherever required to:
- a) Immediately exclude the Bidder / Supplier from the bidding process or call off the pre-contract negotiations without giving any compensation to the Bidder / Supplier. However, the proceedings with the other Bidders / Suppliers may continue;
 - b) Immediately cancel the contract, if already awarded or signed, without giving any compensation to the Bidder / Supplier;
 - c) Recover all sums already paid by Transnet;
 - d) Encash the advance bank guarantee and performance bond or warranty bond, if furnished by the Bidder / Supplier, in order to recover the payments, already made by Transnet, along with interest;
 - e) Cancel all or any other contracts with the Bidder / Supplier;
 - f) Exclude the Bidder / Supplier from entering into any bid with Transnet and other organs of state in future for a specified period; and
 - g) If the Supplier subcontracted a portion of the bid to another person without declaring it to Transnet, Transnet must penalise the Supplier up to 10% of the value of the contract.

9 CONFLICTS OF INTEREST

- 9.1 A conflict of interest includes, inter alia, a situation in which:
- a) A Transnet employee has a personal financial interest in a bidding / supplying entity; and
 - b) A Transnet employee has private interests or personal considerations or has an affiliation or a relationship which affects, or may affect, or may be perceived to affect his / her judgment in action in the best interest of Transnet, or could affect the employee's motivations for acting in a particular manner, or which could result in, or be perceived as favouritism or nepotism.
- 9.2 A Transnet employee uses his / her position, or privileges or information obtained while acting in the capacity as an employee for:
- a) Private gain or advancement; or
 - b) The expectation of private gain, or advancement, or any other advantage accruing to the employee must be declared in a prescribed form.
- Thus, conflicts of interest of any bid committee member or any person involved in the sourcing process must be declared in a prescribed form.
- 9.3 If a Bidder / Supplier has or becomes aware of a conflict of interest i.e. a family, business and / or social relationship between its owner(s) / member(s) / director(s) / partner(s) / shareholder(s) and a Transnet employee / member of Transnet's Board of Directors in respect of a bid which will be considered for the bid process, the Bidder / Supplier:
- a) must disclose the interest and its general nature, in the Request for Proposal ("RFX") declaration form; or
 - b) must notify Transnet immediately in writing once the circumstances has arisen.
- 9.4 The Bidder / Supplier shall not lend to or borrow any money from or enter into any monetary dealings or transactions, directly or indirectly, with any committee member or any person involved in the sourcing process, where this is done, Transnet shall be entitled forthwith to rescind the contract and all other contracts with the Bidder / Supplier.

10 DISPUTE RESOLUTION

10.1 Transnet recognises that trust and good faith are pivotal to its relationship with its Bidders / Suppliers. When a dispute arises between Transnet and its Bidder / Supplier, the parties should use their best endeavours to resolve the dispute in an amicable manner, whenever possible. Litigation in bad faith negates the principles of trust and good faith on which commercial relationships are based. Accordingly, following a restriction process as mentioned in paragraph 6 above, Transnet will not do business with a company that litigates against it in bad faith or is involved in any action that reflects bad faith on its part. Litigation in bad faith includes, but is not limited to the following instances:

- a) **Vexatious proceedings:** these are frivolous proceedings which have been instituted without proper grounds;
- b) **Perjury:** where a supplier make a false statement either in giving evidence or on an affidavit;
- c) **Scurrilous allegations:** where a supplier makes allegations regarding a senior Transnet employee which are without proper foundation, scandalous, abusive or defamatory; and
- d) **Abuse of court process:** when a supplier abuses the court process in order to gain a competitive advantage during a bid process.

11 GENERAL

11.1 This Integrity Pact is governed by and interpreted in accordance with the laws of the Republic of South Africa.

11.2 The actions stipulated in this Integrity Pact are without prejudice to any other legal action that may follow in accordance with the provisions of the law relating to any civil or criminal proceedings.

11.3 The validity of this Integrity Pact shall cover all the bidding processes and will be valid for an indefinite period unless cancelled by either Party.

11.4 Should one or several provisions of this Integrity Pact turn out to be invalid the remainder of this Integrity Pact remains valid.

11.5 Should a Bidder / Supplier be confronted with dishonest, fraudulent or corruptive behaviour of one or more Transnet employees, Transnet expects its Bidders / Suppliers to report this behaviour directly to a senior Transnet official / employee or alternatively by using Transnet's "Tip-Off Anonymous" hotline number 0800 003 056, whereby your confidentiality is guaranteed.

The Parties hereby declare that each of them has read and understood the clauses of this Integrity Pact and shall abide by it. To the best of the Parties' knowledge and belief, the information provided in this Integrity Pact is true and correct.

oooOOOooo

Transnet Port Terminals

Tender Number: TPT/2024/02/0030/56812/RFP

DESCRIPTION OF WORKS : FOR THE PROVISION OF SERVICE TO SUPPLY AND DELIVER CONVEYOR CARRYING IDLERS AND RETURN-IDLER ASSEMBLIES FOR A ONCE OFF PERIOD

NON-DISCLOSURE AGREEMENT

Transnet Port Terminals
Tender Number: TPT/2024/02/0030/56812/RFP

DESCRIPTION OF WORKS : FOR THE PROVISION OF SERVICE TO SUPPLY AND DELIVER CONVEYOR CARRYING IDLERS AND RETURN-IDLER ASSEMBLIES FOR A ONCE OFF PERIOD

Note to tenderers: This Non-Disclosure Agreement is to be completed and signed by an authorised signatory:

THIS AGREEMENT is made effective as of day of 20..... by and between:

TRANSNET SOC LTD

(Registration No. 1990/000900/30), a company incorporated and existing under the laws of South Africa, having its principal place of business at Transnet Corporate Centre 138 Eloff Street , Braamfontein , Johannesburg 2000

and

.....

(Registration No.), a private company incorporated and existing under the laws of South Africa having its principal place of business at

.....

.....

WHEREAS

Transnet and the Company wish to exchange Information [as defined below] and it is envisaged that each party may from time to time receive Information relating to the other in respect thereof. In consideration of each party making available to the other such Information, the parties jointly agree that any dealings between them shall be subject to the terms and conditions of this Agreement which themselves will be subject to the parameters of the Tender Document.

IT IS HEREBY AGREED

1. INTERPRETATION

In this Agreement:

- 1.1 **Agents** mean directors, officers, employees, agents, professional advisers, contractors or sub-contractors, or any Group member;
- 1.2 **Bid or Bid Document** (hereinafter Tender) means Transnet's Request for Information [**RFI**] Request for Proposal [**RFP**] or Request for Quotation [**RFQ**], as the case may be;
- 1.3 **Confidential Information** means any information or other data relating to one party [the **Disclosing Party**] and/or the business carried on or proposed or intended to be carried on by that party and which is made available for the purposes of the Bid to the other party [the **Receiving Party**] or its Agents by the Disclosing Party or its Agents or recorded in agreed minutes following oral disclosure and any other information otherwise made available by the Disclosing Party or its Agents to the Receiving Party or its

**Transnet Port Terminals****Tender Number: TPT/2024/02/0030/56812/RFP****DESCRIPTION OF WORKS : FOR THE PROVISION OF SERVICE TO SUPPLY AND DELIVER CONVEYOR CARRYING IDLERS AND RETURN-IDLER ASSEMBLIES FOR A ONCE OFF PERIOD**

Agents, whether before, on or after the date of this Agreement, and whether in writing or otherwise, including any information, analysis or specifications derived from, containing or reflecting such information but excluding information which:

- 1.3.1 is publicly available at the time of its disclosure or becomes publicly available [other than as a result of disclosure by the Receiving Party or any of its Agents contrary to the terms of this Agreement];
or
- 1.3.2 was lawfully in the possession of the Receiving Party or its Agents [as can be demonstrated by its written records or other reasonable evidence] free of any restriction as to its use or disclosure prior to its being so disclosed; or
- 1.3.3 following such disclosure, becomes available to the Receiving Party or its Agents [as can be demonstrated by its written records or other reasonable evidence] from a source other than the Disclosing Party or its Agents, which source is not bound by any duty of confidentiality owed, directly or indirectly, to the Disclosing Party in relation to such information;
- 1.4 **Group** means any subsidiary, any holding company and any subsidiary of any holding company of either party; and
- 1.5 **Information** means all information in whatever form including, without limitation, any information relating to systems, operations, plans, intentions, market opportunities, know-how, trade secrets and business affairs whether in writing, conveyed orally or by machine-readable medium.

2. CONFIDENTIAL INFORMATION

- 2.1 All Confidential Information given by one party to this Agreement [the **Disclosing Party**] to the other party [the **Receiving Party**] will be treated by the Receiving Party as secret and confidential and will not, without the Disclosing Party's written consent, directly or indirectly communicate or disclose [whether in writing or orally or in any other manner] Confidential Information to any other person other than in accordance with the terms of this Agreement.
- 2.2 The Receiving Party will only use the Confidential Information for the sole purpose of technical and commercial discussions between the parties in relation to the Tender or for the subsequent performance of any contract between the parties in relation to the Tender.
- 2.3 Notwithstanding clause 2.1 above, the Receiving Party may disclose Confidential Information:
 - 2.3.1 to those of its Agents who strictly need to know the Confidential Information for the sole purpose set out in clause 2.2 above, provided that the Receiving Party shall ensure that such Agents are made aware prior to the disclosure of any part of the Confidential Information that the same is confidential and that they owe a duty of confidence to the Disclosing Party. The Receiving Party shall at all times remain liable for any actions of such Agents that would constitute a breach of this Agreement; or

**Transnet Port Terminals****Tender Number: TPT/2024/02/0030/56812/RFP****DESCRIPTION OF WORKS : FOR THE PROVISION OF SERVICE TO SUPPLY AND DELIVER CONVEYOR CARRYING IDLERS AND RETURN-IDLER ASSEMBLIES FOR A ONCE OFF PERIOD**

-
- 2.3.2 to the extent required by law or the rules of any applicable regulatory authority, subject to clause 2.4 below.
- 2.4 In the event that the Receiving Party is required to disclose any Confidential Information in accordance with clause 2.3.2 above, it shall promptly notify the Disclosing Party and cooperate with the Disclosing Party regarding the form, nature, content and purpose of such disclosure or any action which the Disclosing Party may reasonably take to challenge the validity of such requirement.

**Transnet Port Terminals****Tender Number: TPT/2024/02/0030/56812/RFP****DESCRIPTION OF WORKS : FOR THE PROVISION OF SERVICE TO SUPPLY AND DELIVER CONVEYOR CARRYING IDLERS AND RETURN-IDLER ASSEMBLIES FOR A ONCE OFF PERIOD**

- 2.5 In the event that any Confidential Information shall be copied, disclosed or used otherwise than as permitted under this Agreement then, upon becoming aware of the same, without prejudice to any rights or remedies of the Disclosing Party, the Receiving Party shall as soon as practicable notify the Disclosing Party of such event and if requested take such steps [including the institution of legal proceedings] as shall be necessary to remedy [if capable of remedy] the default and/or to prevent further unauthorised copying, disclosure or use.
- 2.6 All Confidential Information shall remain the property of the Disclosing Party and its disclosure shall not confer on the Receiving Party any rights, including intellectual property rights over the Confidential Information whatsoever, beyond those contained in this Agreement.

3. RECORDS AND RETURN OF INFORMATION

- 3.1 The Receiving Party agrees to ensure proper and secure storage of all Information and any copies thereof.
- 3.2 The Receiving Party shall keep a written record, to be supplied to the Disclosing Party upon request, of the Confidential Information provided and any copies made thereof and, so far as is reasonably practicable, of the location of such Confidential Information and any copies thereof.
- 3.3 The Company shall, within 7 [seven] days of receipt of a written demand from Transnet:
- 3.3.1 return all written Confidential Information [including all copies]; and
- 3.3.2 expunge or destroy any Confidential Information from any computer, word processor or other device whatsoever into which it was copied, read or programmed by the Company or on its behalf.
- 3.4 The Company shall on request supply a certificate signed by a director as to its full compliance with the requirements of clause 3.3.2 above.

4. ANNOUNCEMENTS

- 4.1 Neither party will make or permit to be made any announcement or disclosure of its prospective interest in the Tender without the prior written consent of the other party.
- 4.2 Neither party shall make use of the other party's name or any information acquired through its dealings with the other party for publicity or marketing purposes without the prior written consent of the other party.

5. DURATION

The obligations of each party and its Agents under this Agreement shall survive the termination of any discussions or negotiations between the parties regarding the Tender and continue thereafter for a period of 5 [five] years.

6. PRINCIPAL

Each party confirms that it is acting as principal and not as nominee, agent or broker for any other person and that it will be responsible for any costs incurred by it or its advisers in considering or pursuing the Tender and in complying with the terms of this Agreement.

Transnet Port Terminals

Tender Number: TPT/2024/02/0030/56812/RFP

DESCRIPTION OF WORKS : FOR THE PROVISION OF SERVICE TO SUPPLY AND DELIVER CONVEYOR CARRYING IDLERS AND RETURN-IDLER ASSEMBLIES FOR A ONCE OFF PERIOD

7. ADEQUACY OF DAMAGES

Nothing contained in this Agreement shall be construed as prohibiting the Disclosing Party from pursuing any other remedies available to it, either at law or in equity, for any such threatened or actual breach of this Agreement, including specific performance, recovery of damages or otherwise.

8. PRIVACY AND DATA PROTECTION

8.1 The Receiving Party undertakes to comply with South Africa’s general privacy protection in terms Section 14 of the Bill of Rights in connection with this Tender and shall procure that its personnel shall observe the provisions of such Act [as applicable] or any amendments and re-enactments thereof and any regulations made pursuant thereto.

8.2 The Receiving Party warrants that it and its Agents have the appropriate technical and organisational measures in place against unauthorised or unlawful processing of data relating to the Tender and against accidental loss or destruction of, or damage to such data held or processed by them.

9. GENERAL

9.1 Neither party may assign the benefit of this Agreement, or any interest hereunder, except with the prior written consent of the other, save that Transnet may assign this Agreement at any time to any member of the Transnet Group.

9.2 No failure or delay in exercising any right, power or privilege under this Agreement will operate as a waiver of it, nor will any single or partial exercise of it preclude any further exercise or the exercise of any right, power or privilege under this Agreement or otherwise.

9.3 The provisions of this Agreement shall be severable in the event that any of its provisions are held by a court of competent jurisdiction or other applicable authority to be invalid, void or otherwise unenforceable, and the remaining provisions shall remain enforceable to the fullest extent permitted by law.

9.4 This Agreement may only be modified by a written agreement duly signed by persons authorised on behalf of each party.

9.5 Nothing in this Agreement shall constitute the creation of a partnership, joint venture or agency between the parties.

9.6 This Agreement will be governed by and construed in accordance with South African law and the parties irrevocably submit to the exclusive jurisdiction of the South African courts.

Signed

Date

Name

Position

Tenderer