

PART A**INVITATION TO BID**

YOU ARE HEREBY INVITED TO BID FOR REQUIREMENTS OF THE AIRPORTS COMPANY SOUTH AFRICA					
BID NUMBER:	KSIA7227/2023/RFP	CLOSING DATE:	10 May 2024 1	CLOSING TIME:	11 a.m.
DESCRIPTION	CONTRACTOR APPOINTMENT FOR THE ONCE OFF REPLACEMENT OF SUBMERSIBLE PUMPS AT KING SHAKA INTERNATIONAL AIRPORT.				
BID RESPONSE DOCUMENTS MAY BE DEPOSITED IN THE BID BOX SITUATED AT (STREET ADDRESS)					
Airports Company South Africa, King Shaka International Airport, La Mercy, MSO Building, Ground Floor, Reception, near Pickup Zone. Please complete the bid closing register available at reception.					
BIDDING PROCEDURE ENQUIRIES MAY BE DIRECTED TO			TECHNICAL ENQUIRIES MAY BE DIRECTED TO:		
CONTACT PERSON	Johnson Mji		CONTACT PERSON	Johnson Mji	
TELEPHONE NUMBER	071 600 3793		TELEPHONE NUMBER	071 600 3793	
FACSIMILE NUMBER	n/a		FACSIMILE NUMBER	n/a	
E-MAIL ADDRESS	Procurement3.KSIA@airports.co.za		E-MAIL ADDRESS	Procurement3.KSIA@airports.co.za	
SUPPLIER INFORMATION					
NAME OF BIDDER					
POSTAL ADDRESS					
STREET ADDRESS					
TELEPHONE NUMBER	CODE		NUMBER		
CELLPHONE NUMBER					
FACSIMILE NUMBER	CODE		NUMBER		
E-MAIL ADDRESS					
VAT REGISTRATION NUMBER					
SUPPLIER COMPLIANCE STATUS	TAX COMPLIANCE SYSTEM PIN:		OR	CENTRAL SUPPLIER DATABASE No:	MAAA

Tel +27 11 723 1400 Fax +27 11 453 9354
 Western Precinct, Aviation Park, O.R. Tambo International Airport, 1 Jones Road, Kempton Park, Gauteng, South Africa, 1632
 P O Box 75480, Gardenview, Gauteng, South Africa, 2047
www.airports.co.za

ARE YOU THE ACCREDITED REPRESENTATIVE IN SOUTH AFRICA FOR THE GOODS /SERVICES OFFERED?	Yes No [[IF YES ENCLOSE PROOF]]	ARE YOU A FOREIGN BASED SUPPLIER FOR THE GOODS /SERVICES OFFERED?	Yes No [[IF YES, ANSWER THE QUESTIONNAIRE BELOW]]
--	------------------------------------	---	--

QUESTIONNAIRE TO BIDDING FOREIGN SUPPLIERS

IS THE ENTITY A RESIDENT OF THE REPUBLIC OF SOUTH AFRICA (RSA)?	YES NO
DOES THE ENTITY HAVE A BRANCH IN THE RSA?	YES NO
DOES THE ENTITY HAVE A PERMANENT ESTABLISHMENT IN THE RSA?	YES NO
DOES THE ENTITY HAVE ANY SOURCE OF INCOME IN THE RSA?	YES NO
IS THE ENTITY LIABLE IN THE RSA FOR ANY FORM OF TAXATION?	YES NO
IF THE ANSWER IS "NO" TO ALL OF THE ABOVE, THEN IT IS NOT A REQUIREMENT TO REGISTER FOR A TAX COMPLIANCE STATUS SYSTEM PIN CODE FROM THE SOUTH AFRICAN REVENUE SERVICE (SARS) AND IF NOT REGISTER AS PER 2.3 BELOW.	

PART B

TERMS AND CONDITIONS FOR BIDDING

<p>1. BID SUBMISSION:</p> <p>1.1. BIDS MUST BE DELIVERED BY THE STIPULATED TIME TO THE CORRECT ADDRESS. LATE BIDS WILL NOT BE ACCEPTED FOR CONSIDERATION.</p> <p>1.2. ALL BIDS MUST BE SUBMITTED ON THE OFFICIAL FORMS PROVIDED (NOT TO BE RE-TYPED) OR IN THE MANNER PRESCRIBED IN THE BID DOCUMENT.</p> <p>1.3. THIS BID IS SUBJECT TO THE PREFERENTIAL PROCUREMENT POLICY FRAMEWORK ACT, 2000 AND THE PREFERENTIAL PROCUREMENT REGULATIONS, THE GENERAL CONDITIONS OF CONTRACT (GCC) AND, IF APPLICABLE, ANY OTHER SPECIAL CONDITIONS OF CONTRACT.</p> <p>1.4. THE SUCCESSFUL BIDDER MUST ENSURE THEY HAVE A FULLY COMPLETED AND SIGNED WRITTEN CONTRACT POST AWARD.</p>
<p>2. TAX COMPLIANCE REQUIREMENTS</p> <p>2.1 BIDDERS MUST ENSURE COMPLIANCE WITH THEIR TAX OBLIGATIONS.</p> <p>2.2 BIDDERS ARE REQUIRED TO SUBMIT THEIR UNIQUE PERSONAL IDENTIFICATION NUMBER (PIN) ISSUED BY SARS TO ENABLE THE ORGAN OF STATE TO VERIFY THE TAXPAYER'S PROFILE AND TAX STATUS.</p> <p>2.3 APPLICATION FOR TAX COMPLIANCE STATUS (TCS) PIN MAY BE MADE VIA E-FILING THROUGH THE SARS WEBSITE WWW.SARS.GOV.ZA.</p> <p>2.4 BIDDERS MAY ALSO SUBMIT A PRINTED TCS CERTIFICATE TOGETHER WITH THE BID.</p> <p>2.5 IN BIDS WHERE CONSORTIA / JOINT VENTURES / SUB-CONTRACTORS ARE INVOLVED; EACH PARTY MUST SUBMIT A SEPARATE TCS CERTIFICATE / PIN / CSD NUMBER.</p>

Tel +27 11 723 1400 Fax +27 11 453 9354
Western Precinct, Aviation Park, O.R. Tambo International Airport, 1 Jones Road, Kempton Park, Gauteng, South Africa, 1632
P O Box 75480, Gardenview, Gauteng, South Africa, 2047
www.airports.co.za



2.6 WHERE NO TCS PIN IS AVAILABLE BUT THE BIDDER IS REGISTERED ON THE CENTRAL SUPPLIER DATABASE (CSD), A CSD NUMBER MUST BE PROVIDED.

NB: FAILURE TO PROVIDE / OR COMPLY WITH ANY OF THE ABOVE PARTICULARS MAY RENDER THE BID INVALID.

SIGNATURE OF BIDDER:

CAPACITY UNDER WHICH THIS BID IS SIGNED:
 (Proof of authority must be submitted e.g. company resolution)

DATE:

Tel +27 11 723 1400 Fax +27 11 453 9354
Western Precinct, Aviation Park, O.R. Tambo International Airport, 1 Jones Road, Kempton Park, Gauteng, South Africa, 1632
P O Box 75480, Gardenview, Gauteng, South Africa, 2047
www.airports.co.za

Airports Company South Africa SOC Ltd Reg No 1993/004149/30 VAT no 4930138393 Board of Directors: Advocate S Nogxina (Chairperson), M Mpfu (Chief Executive Officer), N Zikala-Mvelase, N Nokwe-Macamo, Y Pillay, K Esterhuizen, GA Victor, D Hlatswayo, Dr KH Badimo, F Sefara (Company Secretary)



BID DOCUMENT

FOR

CONTRACTOR APPOINTMENT FOR THE ONCE OFF REPLACEMENT OF SUBMERSIBLE PUMPS AT KING SHAKA INTERNATIONAL AIRPORT.

Bid Reference Number: KSIA7227/2023/RFP

MONTH 2024 APRIL

Issued by
Airports Company South Africa
__Airport

Note:

Upon Acceptance of the Offer by the Employer, this Tender Document becomes the Contract Document, subsequent to which, all references to the term “Tenderer(s)” then become synonymous with the term “Contractor”.

VOLUME 1

NAME OF BIDDER:

BIDDER’S DETAILS

1.	NAME OF BIDDER (BIDDING ENTITY)	(FULL NAME, i.e. (CC, (Pty) Ltd, JV, SOLE PROPRIETOR)
----	------------------------------------	---

Tel +27 11 723 1400 Fax +27 11 453 9354
Western Precinct, Aviation Park, O.R. Tambo International Airport, 1 Jones Road, Kempton Park, Gauteng, South Africa, 1632
P O Box 75480, Gardenview, Gauteng, South Africa, 2047
www.airports.co.za

Airports Company South Africa SOC Ltd Reg No 1993/004149/30 VAT no 4930138393 Board of Directors: Advocate S Nogxina (Chairperson), M Mpfu (Chief Executive Officer), N Zikala-Mvelase, N Nokwe-Macamo, Y Pillay, K Esterhuizen, GA Victor, D Hlatswayo, Dr KH Badimo, F Sefara (Company Secretary)

2.	TEL NUMBER	
3.	FAX NUMBER	
4.	EMAIL	
5.	NAME OF CONTACT	
6.	NATIONAL TREASURY CSD REGISTRATION NUMBER	

Tel +27 11 723 1400 Fax +27 11 453 9354
Western Precinct, Aviation Park, O.R. Tambo International Airport, 1 Jones Road, Kempton Park, Gauteng, South Africa, 1632
P O Box 75480, Gardenview, Gauteng, South Africa, 2047
www.airports.co.za

Airports Company South Africa SOC Ltd Reg No 1993/004149/30 VAT no 4930138393 Board of Directors: Advocate S Nogxina (Chairperson), M Mpfu (Chief Executive Officer), N Zikala-Mvelase, N Nokwe-Macamo, Y Pillay, K Esterhuizen, GA Victor, D Hlatswayo, Dr KH Badimo, F Sefara (Company Secretary)

Contents	
The BID	
Part T1: Tendering procedures	
T1.1	Tender Notice and Invitation to Tender
T1.2	Tender Data
Part T2: Returnable documents	
T2.1	List of Returnable Documents
T2.2	Returnable Schedules
The Contract	
Part C1: Agreement and Contract Data	
C1.1	Form of Offer and Acceptance
C1.2	Contract Data
Part C2: Pricing data	
C2.1	Pricing Instructions
C2.2	ACSA Service Level Agreement
C2.3	Bills of Quantities
Part C3: Scope of Work	
Part C4: Site information	
Part C5: Annexures	

Tel +27 11 723 1400 Fax +27 11 453 9354
 Western Precinct, Aviation Park, O.R. Tambo International Airport, 1 Jones Road, Kempton Park, Gauteng, South Africa, 1632
 P O Box 75480, Gardenview, Gauteng, South Africa, 2047
www.airports.co.za

Airports Company South Africa SOC Ltd Reg No 1993/004149/30 VAT no 4930138393 Board of Directors: Advocate S Nogxina (Chairperson), M Mpfu (Chief Executive Officer), N Zikala-Mvelase, N Nokwe-Macamo, Y Pillay, K Esterhuizen, GA Victor, D Hlatswayo, Dr KH Badimo, F Sefara (Company Secretary)



T1.1 Tender Notice and Invitation to Tender

Airports Company South Africa SOC Limited invites tenders for the Contractor appointment for the once off Replacement of **Submersible Pumps at King Shaka International Airport**.

It is estimated that bidders should have a contractor grading designation of 3ME or higher as stated on the Tender Data may submit tender offers.

Tender Document Availability

Tender documents are available from 8 April 2024 for free download from National Treasury's eTender Publication Portal (<http://www.etenders.gov.za>) and ACSA Tender Bulletin website - <http://www.airports.co.za/business/tender-bulletin/current-and-future-tenders>. Kindly print and complete.

Queries relating to the issue of these documents may be addressed to Mr Johnson Mji **071 600 3793**, E-mail address: Procurement3.KSIA@airports.co.za

Closing date for enquiries is 26 April 2024

Compulsory Site Inspection and Non-Compulsory Briefing Session

A compulsory site meeting/inspection and Non-compulsory briefing session with representatives of the Employer will take place at **Airports Company South Africa, King Shaka International Airport, La Mercy, MSO Building, Ground Floor, Reception, near Pickup Zone on 18 April 2024 starting at 10 a.m.**

PPE and Identification Required

- Normal PPE with safety shoes/closed shoes or boots
- Original Identity/Passport document.

Parking

Free of charge parking at Shaded Parking. Tickets will be validated at the meeting.

Payment for Site Inspection

1-day Personal Temporary Permit R179.55 per person payable by cash or EFT at ACSA Permit Office. Forms will be issued to the bidders at the Permit Office for those bidders who meet the above requirements (payment and Original Identification/Passport). Please note that this payment is nonrefundable.

Closing Date

The closing date and time for receipt of tenders is 10 May 2024 **at 11 a.m.** (South African Time). Tenders must be placed inside the **Tender Box at the Airport:**

Airports Company South Africa, King Shaka International Airport, La Mercy, MSO Building, Ground Floor, Reception, near Pickup Zone. Please complete the bid closing register available at reception.



Tender Box is operational from Monday-Friday from 8 am – 4 pm. It is closed on Weekends and also closed during the public holidays.

**Telephonic, telegraphic, telex, facsimile, e-mailed tenders will not be accepted.
No late tenders will be accepted.**

Bidders to ensure that their names and contacts are reflected on the cover of the bid document.
Tenders may only be submitted on the tender documentation that is issued.
Requirements for sealing, addressing, delivery, opening and assessment of tenders are stated in the Tender Data Bidders to ensure that their names and contacts are reflected on the cover of the bid document.

Tenders may only be submitted on the tender documentation that is issued.

Requirements for sealing, addressing, delivery, opening and assessment of tenders are stated in the Tender Data.

T1.2 Tender Data

The conditions of tender are the Standard Conditions of Tender as contained in Annex C of the CIDB Standard for Uniformity in Construction Procurement (8 August 2019) as published in Government Gazette 42622, Board Notice 423 of 2019 of 8 August 2019. (See www.cidb.org.za).

The Standard Conditions of Tender make several references to the Tender Data for details that apply specifically to this tender. The Tender Data shall have precedence in the interpretation of any ambiguity or inconsistency between it and the Standard Conditions of Tender.

Each item of data given below is cross-referenced to the clause in the Standard Conditions of Tender to which it mainly applies.

Clause Number	Tender Data
C.1	GENERAL
C.1.1	The Employer is AIRPORTS COMPANY SOUTH AFRICA SOC LIMITED
C.1.2	<p>The Tender Documents issued by the Employer comprise:</p> <p>Part T1: Tendering Procedures</p> <ul style="list-style-type: none"> T1.1 Tender notice and invitation to tender T1.2 Tender data T1.3 CIDB Standard conditions of tender <p>Part T2: Returnable Document</p> <ul style="list-style-type: none"> T2.1 List of returnable documents T2.2 Returnable schedule <p>Part C1: Agreements and Contract Data</p> <ul style="list-style-type: none"> C1.1 Form of offer and acceptance C1.2 Contract data <p>Part C2: Pricing Schedule</p> <ul style="list-style-type: none"> C2.1 Pricing instructions C2.2 ACSA Service Level Agreement C2.3 Bills of Quantities <ul style="list-style-type: none"> Section 1 - Preliminaries <p>Part C3: Scope of work</p> <p>Part C4: Site information</p> <p>Part C5: Annexures</p>
C.1.4	<p>The Employer's Agent is Johnson Mji (SCM Representative) Telephone number: 071 600 3793. Email address: Procurement3.KSIA@airports.co.za</p> <p>All communication during the Tender period shall not be made to the Principal Agent but to ACSA's Supply Chain Department</p>
C.1.5	<p>C1.5 Cancellation and Re-Invitation of Tenders</p> <p>C1.5.1 An employer may, prior to the award of the tender, cancel a tender if-</p> <ul style="list-style-type: none"> a) due to changed circumstances, there is no longer a need for the engineering and construction works specified in the invitation; b) funds are no longer available to cover the total envisaged expenditure; or c) no acceptable tenders are received. d) there is a material irregularity in the tender process. <p>C.1.5.2 The decision to cancel a tender invitation must be published in the same manner in which the original tender invitation was advertised</p>

	<p>C.1.5.3 An employer may only with the prior approval of the relevant treasury cancel a tender invitation for the second time.</p>
C.1.6	<p>Procurement procedures</p> <p>C.1.6.1 General</p> <p>Unless otherwise stated in the tender data, a contract will, subject to C.3.13, be concluded with the tenderer who in terms of C.3.11 is the highest ranked or the tenderer scoring the highest number of tender evaluation points, as relevant, based on the tender submissions that are received at the closing time for tenders.</p> <p>C.1.6.2 Competitive negotiation procedure</p> <p>C.1.6.2.1 Where the tender data require that the competitive negotiation procedure is to be followed, tenderers shall submit tender offers in response to the proposed contract in the first round of submissions. Notwithstanding the requirements of C.3.4, the employer shall announce only the names of the tenderers who make a submission. The requirements of C.8 relating to the material deviations or qualifications which affect the competitive position of tenderers shall not apply.</p> <p>C.1.6.2.2 All responsive tenderers or at least a minimum of not less than three responsive tenderers that are highest ranked in terms of the evaluation criteria stated in the tender data shall be invited to enter into competitive negotiations based on the principle of equal treatment, keeping confidential the proposed solutions and associated information.</p> <p>Notwithstanding the provisions of C.2.17, the employer may request that tenders be clarified, specified and fine-tuned in order to improve a tenderer's competitive position provided that such clarification, specification, fine-tuning or additional information does not alter any fundamental aspects of the offers or impose substantial new requirements which restrict or distort competition or have a discriminatory effect.</p> <p>C.1.6.2.3 At the conclusion of each round of negotiations, tenderers shall be invited by the employer to revise their tender offer based on the same evaluation criteria, with or without adjusted weightings. Tenderers shall be advised when they are to submit their best and final offer.</p> <p>C.1.6.2.4 The contract shall be awarded in accordance with the provisions of C.3.11 and C.3.13 after tenderers have been requested to submit their best and final offer.</p>
C.2	TENDERER'S OBLIGATIONS
C.2.1	<p>Eligibility</p> <p>C.2.1.1 Submit a tender offer only if the tenderer satisfies the criteria stated in the tender data and the tenderer, or any of his principals, is not under any restriction to do business with employer.</p> <p>C.2.1.2 Notify the employer of any proposed material change in the capabilities or formation of the tendering entity (or both) or any other criteria which formed part of the qualifying requirements used by the employer as the basis in a prior process to invite the tenderer to submit a tender offer and obtain the employer's written approval to do so prior to the closing time for tenders.</p>
C.2.2	<p>Cost of tendering</p> <p>C.2.2.1 Accept that, unless otherwise stated in the tender data, the employer will not compensate the tenderer for any costs incurred in the preparation and submission of a tender offer, including the costs of any testing necessary to demonstrate that aspects of the offer complies with requirements.</p>

C.2.3	<p>Check documents</p> <p>Check the tender documents on receipt for completeness and notify the employer of any discrepancy or omission.</p>
C.2.4	<p>Confidentiality and copyright of documents</p> <p>Treat as confidential all matters arising in connection with the tender. Use and copy the documents issued by the employer only for the purpose of preparing and submitting a tender offer in response to the invitation.</p>
C.2.6	<p>Acknowledge addenda</p> <p>Acknowledge receipt of addenda to the tender documents, which the employer may issue, and if necessary apply for an extension to the closing time stated in the tender data, in order to take the addenda into account.</p>
C.2.7	<p>Clarification meeting</p> <p>The arrangements for a compulsory briefing session are as stated in the Tender Notice and Invitation to Tender (T1.1).</p> <p>Tenderers must sign the attendance list in the name of the tendering entity. Addenda will be issued to and tenders will be received only from those tendering entities appearing on the attendance list.</p>
C.2.8	<p>Seek clarification</p> <p>Request clarification of the tender documents, if necessary, by notifying the employer at least five (5) working days before the closing time stated in the tender data.</p>
C.2.9	<p>Insurance</p> <p>Be aware that the extent of insurance to be provided by the employer (if any) might not be for the full cover required in terms of the conditions of contract identified in the contract data. The tenderer is advised to seek qualified advice regarding insurance.</p>
C.2.10.3	<p>This contract shall not be subject to Contract Price Adjustments, foreign fluctuations, etc and all rates and prices shall remain FIXED, final and binding for the full duration of this contract.</p>
C.2.11	<p>Alterations to documents</p> <p>Do not make any alterations or additions to the tender documents, except to comply with instructions issued by the employer, or necessary to correct errors made by the tenderer. All signatories to the tender offer shall initial all such alterations.</p>
C.2.12	<p>Alternative bids will not be considered. (If applicable please copy the clause as per SFU 2019)</p>
C.2.13	<p>Submitting a tender offer</p> <p>C.2.13.1 Submit one tender offer only, either as a single tendering entity or as a member in a joint venture to provide the whole of the works identified in the contract data and described in the scope of works, unless stated otherwise in the tender data.</p> <p>C.2.13.2 Return all returnable documents to the employer after completing them in their entirety, either electronically (if they were issued in electronic format) or by writing legibly in non-erasable ink.</p> <p>C.2.13.3 Submit the parts of the tender offer communicated on paper as an original plus the number of copies stated in the tender data, with an English translation of any documentation in a language other than English, and the parts communicated electronically in the same format as they were issued by the employer.</p> <p>C.2.13.4 Sign the original and all copies of the tender offer where required in terms of the tender data. The employer will hold all authorized signatories liable on behalf of the tenderer. Signatories for tenderers</p>

	<p>proposing to contract as joint ventures shall state which of the signatories is the lead partner whom the employer shall hold liable for the purpose of the tender offer.</p> <p>C.2.13.5 Seal the original and each copy of the tender offer as separate packages marking the packages as "ORIGINAL" and "COPY". Each package shall state on the outside the employer's address and identification details stated in the tender data, as well as the tenderer's name and contact address.</p>
C.2.14	<p>Information and data to be completed in all respects</p> <p>Accept that tender offers, which do not provide all the data or information requested completely and in the form required, may be regarded by the employer as non-responsive.</p>
C.2.15	<p>Closing time</p> <p>The Employer's details and address for delivery of tender offers and identification details that are to be shown on each tender offer package are:</p> <p>Location of tender box:</p> <p>Airports Company SA SOC Ltd, King Shaka International Airport La Mercy, MSO Building (Multi Story Office) Ground Floor, Reception, near Pickup zone From Monday to Friday (8a.m to 4p.m) Closed during weekends and public holidays.</p> <p>Identification details: Bid Ref. No: KSIA7227/2023/RFP</p> <p>Title: Contractor appointment for the once off Replacement of Submersible Pumps at King Shaka International Airport</p> <p>Closing Date: 10 May 2024 at 11 a.m.</p>
C.2.16	<p>Tender offer validity</p> <p>C.2.16.1 Hold the tender offer(s) valid for Twelve Weeks for acceptance by the employer at any time during the validity period stated after the closing time stated in the tender data.</p> <p>C.2.16.2 If requested by the employer, consider extending the validity period stated in the tender data for an agreed additional period with or without any conditions attached to such extension.</p> <p>C.2.16.3 Accept that a tender submission that has been submitted to the employer may only be withdrawn or substituted by giving the employer's agent written notice before the closing time for tenders that a tender is to be withdrawn or substituted. If the validity period stated in C.2.16 lapses before the employer evaluating tender, the contractor reserves the right to review the price based on Consumer Price Index (CPI).</p> <p>C.2.16.4 Where a tender submission is to be substituted, a tenderer must submit a substitute tender in accordance with the requirements of C.2.13 with the packages clearly marked as "SUBSTITUTE".</p>
C.2.17	<p>Clarification of tender offer after submission</p> <p>Provide clarification of a tender offer in response to a request to do so from the employer during the evaluation of tender offers. This may include providing a breakdown of rates or prices and correction of arithmetical errors by the adjustment of certain rates or item prices (or both). No change in the competitive position of tenderers or substance of the tender offer is sought, offered, or permitted.</p>
C.2.20	<p>Submit securities, bonds and policies</p>

	If requested, submit for the employer's acceptance before formation of the contract, all securities, bonds, guarantees, policies and certificates of insurance required in terms of the conditions of contract identified in the contract data.
C.3	EMPLOYER'S UNDERTAKINGS
C.3.1	Respond to requests from the tenderer The Employer will respond to requests for clarification received up to five (5) working days before the tender closing time.
C.3.2	Issue Addenda Addenda will be issued until three (3) working days before the tender closing time.
C.3.3	Return late tender offers Tender offers received after the closing time stated in the Tender Data will be returned, unopened, (unless it is necessary to open a tender submission to obtain a forwarding address), to the tenderer concerned.
C.3.4	There will be public opening of tenders after the closing date and time (10 May 2024 at 11 a.m.) . Tender opening register will be made available to all bidders who submitted a bid.
C.3.7	Grounds for rejection and disqualification Determine whether there has been any effort by a tenderer to influence the processing of tender offers and instantly disqualify a tenderer (and his tender offer) if it is established that he engaged in corrupt or fraudulent practices.
C.3.8	Test for Responsiveness C.3.8.1 Determine, after opening and before detailed evaluation, whether each tender offer properly received: a) complies with the requirements of these Conditions of Tender, (scope work, pricing, proposed amendments and qualifications, cover letters must be considered) b) has been properly and fully completed and signed, and c) is responsive to the other requirements of the tender documents.(check certificates if attached, eg Qualifications, etc allow bidder reasonable time to submit.) C.3.8.2 A responsive tender is one that conforms to all the terms, conditions, and specifications of the tender documents without material deviation or qualification. A material deviation or qualification is one which, in the Employer's opinion, would: a) detrimentally affect the scope, quality, or performance of the works, services or supply identified in the Scope of Work, b) significantly change the Employer's or the tenderer's risks and responsibilities under the contract, or c) affect the competitive position of other tenderers presenting responsive tenders, if it were to be rectified. Reject a non-responsive tender offer, and not allow it to be subsequently made responsive by correction or withdrawal of the non-conforming deviation or reservation.
C.3.9	Arithmetical errors, omissions and discrepancies. C.3.9.1 Check responsive tenders for discrepancies between amounts in words and amounts in figures. Where there is a discrepancy between the amounts in figures and the amount in words, the amount in words shall govern.



C.3.9.2 Check the highest ranked tender or tenderer with the highest number of tender evaluation points after the evaluation of tender offers in accordance with C.3.11 for:

- a) the gross misplacement of the decimal point in any unit rate;
- b) omissions made in completing the pricing schedule or bills of quantities; or
- c) arithmetic errors in:
 - (i) line item totals resulting from the product of a unit rate and a quantity in bills of quantities or schedules of prices; or
 - (ii) the summation of the prices.

C.3.9.3 Notify the tenderer of all errors or omissions that are identified in the tender offer and either confirm the tender offer as tendered or accept the corrected total of prices.

C.3.9.4 Where the tenderer elects to confirm the tender offer as tendered, correct the errors as follows:

- a) If bills of quantities or pricing schedules apply and there is an error in the line item total resulting from the product of the unit rate and the quantity, the line item total shall govern and the rate shall be corrected. Where there is an obviously gross misplacement of the decimal point in the unit rate, the line item total as quoted shall govern, and the unit rate shall be corrected.
- b) Where there is an error in the total of the prices either as a result of other corrections required by this checking process or in the tenderer's addition of prices, the total of the prices shall govern and the tenderer will be asked to revise selected item prices (and their rates if bills of quantities apply) to achieve the tendered total of the prices.

C.3.10 **Clarification of a tender offer**
Obtain clarification from a tenderer on any matter that could give rise to ambiguity in a contract arising from the tender offer.

C.3.11 **A staged approach will be used to evaluate tenders**

Stage 1	Stage 2	Stage 3	Stage 4	Stage 5	Stage 6
Test for Responsiveness As per Clause C3.8	Mandatory Requirements	Evaluate on functionality or the technical aspect of the bid	Evaluate price and Preference	Post tender negotiations (If Applicable)	Security Vetting (If Applicable)

Stage 1 Test for responsiveness as outlined by the clause C3.8 above.

Stage 2 Mandatory Administration Criteria

- (a) Completed in full and signed Form of offer C1.1. Refer page 74 of 127 in the contract document
- (b) It is estimated that bidders should have a contractor grading designation of 3ME or higher as stated on the Tender Data may submit tender offers. Refer Form B2 on page 58 of 127
- (c) Bidders must attend a compulsory site meeting/inspection. **Please complete attendance register at the meeting.**

Stage 4 Functionality Evaluation Criteria

Functionality is the terminology used to define the technical ability of the Tenderer, based on experience to deliver the required product in accordance with the specialised quality, reliability and functionality.

The functionality evaluation will be conducted by the end-user/operations/the Tender Preparation and Evaluation Committee which comprises of various skilled and experienced members from diverse professional disciplines. The evaluation process will be based on functionality criteria. The criteria will be as follows:

Functionality Criteria

The functional evaluation will be based on a threshold, where bidders which fail to achieve a minimum of 65 points on the functional stage will not be considered further in the evaluation. The thresholds on each element of the evaluation are as follows:

Qualifications. Please refer to page 63 & 64 of 127 Form C7 C8 CVs, Qualifications for Key Personnel

Role	Qualification	Score
Millwright x 1 Please provide: Certified Proof of Qualification	N6 in Engineering plus SAQA Accredited trade test Millwright	20
	SAQA Accredited trade test Millwright	15
	Not Relevant	0
Maximum Score		20
Minimum Score		15

NB: All minimum threshold per resource must be met to be evaluated further.

OR Please refer to page Please refer to page 63 & 64 of 127 Form C7 C8 CVs, Qualifications for Key Personnel

Role	Qualification	Score
Fitter x 1 Please provide: Certified Proof of Qualification	N6 in Engineering plus SAQA Accredited trade test Fitter	10
	SAQA Accredited trade test Fitter	7.5
	Not Relevant	0
Maximum Score		10
Minimum Score		7.5
Role	Qualification	Score
Electrician x 1 Please provide: Certified Proof of Qualification	N6 in Engineering plus SAQA Accredited trade test Electrician	10
	SAQA Accredited trade test Electrician	7.5
	Not Relevant	0
Maximum Score		10
Minimum Score		7.5

BIDDER TO PROVIDE EITHER A MILLWRIGHT OR TWO ARTISANS (FITTER AND ELECTRICIAN)

Please refer to page 63 & 64 of 127 Form C7 C8 CVs, Qualifications for Key Personnel

Role	Qualification	Score
Technical Assistants x 1 Please provide: Certified Proof of Qualification	N3 or higher Engineering Certificate	15
	Matric or N2 Engineering Certificate	10
	Qualification not relevant	0
Maximum Score		15
Minimum Score		10

Please refer to page 38-43 of 127 Form A5, A6,A7,A8 and A9 for Recent experience, Completion certificate, Reference letters for completed projects, Contract values for previous completed projects and current commitments respectively

EXPERIENCE

Role	Experience	Score
Millwright x 1 Please provide: <u>Comprehensive</u> CVs for each member of the team to demonstrate technical skills and projects worked on (relating to the advert). Please ensure that the correct supporting CV is included in the submission.	More than 3 years' experience post trade test on the maintenance or replacements of Pumps	20
	2-3 years' experience post trade test on the maintenance or replacements of Pumps	15
	No relevant Experience	0
Maximum Score		20
Minimum Score		15

NB: All minimum threshold per resource must be met to be evaluated further.

Role	Experience	Score
Fitter x 1 Please provide: Comprehensive CVs for each member of the team to demonstrate technical skills and projects worked on (relating to the advert). Please ensure that the correct supporting CV is included in the submission.	More than 3 years' experience post trade test on the maintenance or replacements of Pumps	10
	2-3 years' experience post trade test on the maintenance or replacements of Pumps	7.5
	No relevant Experience	0
Maximum Score		10
Minimum Score		7.5
Role	Experience	Score

<p>Electrician x 1 Please provide: Comprehensive CVs for each member of the team to demonstrate technical skills and projects worked on (relating to the advert). Please ensure that the correct supporting CV is included in the submission.</p>	More than 3 years' experience post trade test on the maintenance or replacements of Pumps	10																								
	2-3 years' experience post trade test in industrial electrical installations including control panels and PLCs.	7.5																								
	No relevant Experience	0																								
	Maximum Score		10																							
	Minimum Score		7.5																							
BIDDER TO PROVIDE EITHER A MILLWRIGHT OR TWO ARTISANS (FITTER AND ELECTRICIAN)																										
<table border="1"> <thead> <tr> <th>Role</th> <th>Experience</th> <th>Score</th> </tr> </thead> <tbody> <tr> <td rowspan="3"> <p>Technical Assistants x 1 Please provide: <u>Comprehensive</u> CVs for each member of the team to demonstrate technical skills and projects worked on (relating to the advert). Please ensure that the correct supporting CV is included in the submission.</p> </td> <td>More than 2 years' experience in installation of mechanical system</td> <td>15</td> </tr> <tr> <td>1-2 years' experience in installation of mechanical system</td> <td>10</td> </tr> <tr> <td>No relevant Experience</td> <td>0</td> </tr> <tr> <td colspan="2" style="text-align: center;">Maximum Score</td> <td>15</td> </tr> <tr> <td colspan="2" style="text-align: center;">Minimum Score</td> <td>10</td> </tr> </tbody> </table>			Role	Experience	Score	<p>Technical Assistants x 1 Please provide: <u>Comprehensive</u> CVs for each member of the team to demonstrate technical skills and projects worked on (relating to the advert). Please ensure that the correct supporting CV is included in the submission.</p>	More than 2 years' experience in installation of mechanical system	15	1-2 years' experience in installation of mechanical system	10	No relevant Experience	0	Maximum Score		15	Minimum Score		10								
Role	Experience	Score																								
<p>Technical Assistants x 1 Please provide: <u>Comprehensive</u> CVs for each member of the team to demonstrate technical skills and projects worked on (relating to the advert). Please ensure that the correct supporting CV is included in the submission.</p>	More than 2 years' experience in installation of mechanical system	15																								
	1-2 years' experience in installation of mechanical system	10																								
	No relevant Experience	0																								
Maximum Score		15																								
Minimum Score		10																								
<p><i>NB: All minimum threshold per resource must be met to be evaluated further.</i></p>																										
<p>Please refer to page 38 – 43 of 127 Form A5, A6,A7,A8 and A9 for Recent experience, Completion certificate, Reference letters for completed projects, Contract values for previous completed projects and current commitments respectively</p>																										
<p>Company Experience.</p> <table border="1"> <thead> <tr> <th>Criteria</th> <th>Sub-Criteria</th> <th>Score</th> </tr> </thead> <tbody> <tr> <td rowspan="4"> <p>Bidder must provide a minimum of one (1) Trade reference letter showing successful completion of similar installation/refurbishment work of pumps. The letter or completion certificate must be on company letter head and include contactable references.</p> </td> <td>Relevant Work</td> <td></td> </tr> <tr> <td>Provide two or more positive response (proof of successful completion)</td> <td>30</td> </tr> <tr> <td>Provide one positive response (proof of successful completion)</td> <td>15</td> </tr> <tr> <td>Negative Response</td> <td>0</td> </tr> <tr> <td colspan="2" style="text-align: center;">Maximum Score</td> <td>30</td> </tr> <tr> <td colspan="2" style="text-align: center;">Minimum Score</td> <td>15</td> </tr> <tr> <td colspan="2">Total Maximum Score</td> <td>100</td> </tr> <tr> <td colspan="2">Total Minimum Score</td> <td>65</td> </tr> </tbody> </table>			Criteria	Sub-Criteria	Score	<p>Bidder must provide a minimum of one (1) Trade reference letter showing successful completion of similar installation/refurbishment work of pumps. The letter or completion certificate must be on company letter head and include contactable references.</p>	Relevant Work		Provide two or more positive response (proof of successful completion)	30	Provide one positive response (proof of successful completion)	15	Negative Response	0	Maximum Score		30	Minimum Score		15	Total Maximum Score		100	Total Minimum Score		65
Criteria	Sub-Criteria	Score																								
<p>Bidder must provide a minimum of one (1) Trade reference letter showing successful completion of similar installation/refurbishment work of pumps. The letter or completion certificate must be on company letter head and include contactable references.</p>	Relevant Work																									
	Provide two or more positive response (proof of successful completion)	30																								
	Provide one positive response (proof of successful completion)	15																								
	Negative Response	0																								
Maximum Score		30																								
Minimum Score		15																								
Total Maximum Score		100																								
Total Minimum Score		65																								



Stage 5 Price and Preference

This is the final stage of the evaluation process and will be based on the PPPFA preference point system. Bidders will be ranked by applying the preferential point scoring *80/20 for bids with the rand value equal to or below R50 million*. A maximum of 80 points is allocated for price based on the following formulae

80/20

$$Ps = 80 \left(1 - \frac{Pt - Pmin}{Pmin} \right)$$

Where:

- Ps = Points scored for price of tender under consideration
- Pt = Price of tender under consideration
- Pmin = Price of lowest acceptable tender

Evaluation of Preference

ACSA will score specific goals out of 20 in accordance with the PPP Regulations 2022/2023. If a bidder fails to meet the Specific goals as outlined on the table below and to submit proof, the bidder will score zero (0) out of 20. ACSA will not disqualify the bidder. See below Specific goals that must be achieved for this bid:

Category	Specific Goals	Score	
		20	10
Construction	51% owned by Black male and Black women and Black youth and People living with disabilities	20	10
	51% owned by Black male or Black women or Black youth or People living with disabilities (at least two of the above designated groups must achieved)	15	8
	51% owned by Black male or Black women or Black youth or People living with disabilities	10	6
	Less than 51% owned by Black male, Black women, Black youth, People living with disabilities	5	4
	Other	0	0

Stage 6 Objective. Criteria N/A

	<p>Determine acceptability of preferred tenderer:</p> <p>Perform a risk analysis on the preferred tenderer to ascertain if any of the following might present an unacceptable commercial risk to the employer:</p> <ul style="list-style-type: none"> • Unduly high or unduly low tendered rates or amounts in the tender offer; • Contract data provided by the tenderer; or • The contents of the tender returnable which are to be included in the contract.
C.3.12	<p>Insurance provided by the employer Refer to Contract Data</p>
C.3.13	<p>C.3.13 Acceptance of tender offer</p> <p>Accept the tender offer; if in the opinion of the employer, it does not present any risk and only if the tenderer:</p> <p>a) is not under restrictions, or has principals who are under restrictions, preventing participating in the employer's procurement;</p> <p>b) can, as necessary and in relation to the proposed contract, demonstrate that he or she possesses the professional and technical qualifications, professional and technical competence, financial resources, equipment and other physical facilities, managerial capability, reliability, experience and reputation, expertise and the personnel, to perform the contract;</p> <p>c) has the legal capacity to enter into the contract;</p> <p>d) is not; insolvent, in receivership, under Business Rescue as provided for in chapter 6 of the Companies Act No. 2008, bankrupt or being wound up, has his/her affairs administered by a court or a judicial officer, has suspended his/her business activities or is subject to legal proceedings in respect of any of the foregoing;</p> <p>e) complies with the legal requirements, if any, stated in the tender data; and</p> <p>f) is able, in the opinion of the employer, to perform the contract free of conflicts of interest.</p>

Standard Conditions of Tender

C.1 General

C.1.1 Actions

C.1.1.1 The employer and each tenderer submitting a tender offer shall comply with these conditions of tender. In their dealings with each other, they shall discharge their duties and obligations as set out in C.2 and C.3, timeously and with integrity, and behave equitably, honestly and transparently, comply with all legal obligations and not engage in anticompetitive practices.

C.1.1.2 The employer and the tenderer and all their agents and employees involved in the tender process shall avoid conflicts of interest and where a conflict of interest is perceived or known, declare any such conflict of interest, indicating the nature of such conflict. Tenderers shall declare any potential conflict of interest in their tender submissions. Employees, agents and advisors of the employer shall declare any conflict of interest to whoever is responsible for overseeing the procurement process at the start of any deliberations relating to the procurement process or as soon as they become aware of such conflict and abstain from any decisions where such conflict exists or recuse themselves from the procurement process, as appropriate.

Note: 1) A conflict of interest may arise due to a conflict of roles which might provide an incentive for improper acts in some circumstances. A conflict of interest can create an appearance of impropriety that can undermine confidence in the ability of that person to act properly in his or her position even if no improper acts result.

2) Conflicts of interest in respect of those engaged in the procurement process include direct, indirect or family interests in the tender or outcome of the procurement process and any personal bias, inclination, obligation, allegiance or loyalty which would in any way affect any decisions taken.

C.1.1.3 The employer shall not seek and a tenderer shall not submit a tender without having a firm intention and the capacity to proceed with the contract.

C.1.2 Tender Documents

The documents issued by the employer for the purpose of a tender offer are listed in the tender data.

C.1.3 Interpretation

C.1.3.1 The tender data and additional requirements contained in the tender schedules that are included in the returnable documents are deemed to be part of these conditions of tender.

C.1.3.2 These conditions of tender, the tender data and tender schedules which are required for tender evaluation purposes, shall form part of any contract arising from the invitation to tender.

C.1.3.3 For the purposes of these conditions of tender, the following definitions apply:

- a) **conflict of interest** means any situation in which:
 - i) someone in a position of trust has competing professional or personal interests

- which make it difficult to fulfill his or her duties impartially;
- ii) an individual or tenderer is in a position to exploit a professional or official capacity in some way for their personal or corporate benefit; or
 - iii) incompatibility or contradictory interests exist between an employee and the tenderer who employs that employee.
- b) **comparative offer** means the price after the factors of a non-firm price and all unconditional discounts it can be utilised to have been taken into consideration;
 - c) **corrupt practice** means the offering, giving, receiving or soliciting of anything of value to influence the action of the employer or his staff or agents in the tender process;
 - d) **fraudulent practice** means the misrepresentation of the facts in order to influence the tender process or the award of a contract arising from a tender offer to the detriment of the employer, including collusive practices intended to establish prices at artificial levels;

C.1.4 Communication and employer's agent

Each communication between the employer and a tenderer shall be to or from the employer's agent only, and in a form that can be readily read, copied and recorded. Communications shall be in the English language. The employer shall not take any responsibility for non-receipt of communications from or by a tenderer. The name and contact details of the employer's agent are stated in the tender data.

C.1.5 Cancellation and Re-Invitation of Tenders

C.1.5.1 An employer may, prior to the award of the tender, cancel a tender if-

- a) due to changed circumstances, there is no longer a need for the engineering and construction works specified in the invitation;
- b) funds are no longer available to cover the total envisaged expenditure; or
- c) no acceptable tenders are received.
- d) there is a material irregularity in the tender process.

C.1.5.2 The decision to cancel a tender invitation must be published in the same manner in which the original tender invitation was advertised.

C.1.5.3 An employer may only with the prior approval of the relevant treasury cancel a tender invitation for the second time.

C.1.6 Procurement procedures

C.1.6.1 General

Unless otherwise stated in the tender data, a contract will, subject to C.3.13, be concluded with the tenderer who in terms of C.3.11 is the highest ranked or the tenderer scoring the highest number of tender evaluation points, as relevant, based on the tender submissions that are received at the closing time for tenders.

C.1.6.2 Competitive negotiation procedure

C.1.6.2.1 Where the tender data require that the competitive negotiation procedure is to be followed, tenderers shall submit tender offers in response to the proposed contract in the first



round of submissions. Notwithstanding the requirements of C.3.4, the employer shall announce only the names of the tenderers who make a submission. The requirements of C.8 relating to the material deviations or qualifications which affect the competitive position of tenderers shall not apply.

C.1.6.2.2 All responsive tenderers or at least a minimum of not less than three responsive tenderers that are highest ranked in terms of the evaluation criteria stated in the tender data shall be invited to enter into competitive negotiations based on the principle of equal treatment, keeping confidential the proposed solutions and associated information.

Notwithstanding the provisions of C.2.17, the employer may request that tenders be clarified, specified and fine-tuned in order to improve a tenderer's competitive position provided that such clarification, specification, fine-tuning or additional information does not alter any fundamental aspects of the offers or impose substantial new requirements which restrict or distort competition or have a discriminatory effect.

C.1.6.2.3 At the conclusion of each round of negotiations, tenderers shall be invited by the employer to revise their tender offer based on the same evaluation criteria, with or without adjusted weightings. Tenderers shall be advised when they are to submit their best and final offer.

C.1.6.2.4 The contract shall be awarded in accordance with the provisions of C.3.11 and C.3.13 after tenderers have been requested to submit their best and final offer.

C.1.6.3 Proposal procedure using the two stage-system

C.1.6.3.1 Option 1

Tenderers shall in the first stage submit technical proposals and, if required, cost parameters around which a contract may be negotiated. The employer shall evaluate each responsive submission in terms of the method of evaluation stated in the tender data, and in the second stage negotiate a contract with the tenderer scoring the highest number of evaluation points and award the contract in terms of these conditions of tender.

C.1.6.3.2 Option 2

C.1.6.3.2.1 Tenderers shall submit in the first stage only technical proposals. The employer shall invite all responsive tenderers to submit tender offers in the second stage, following the issuing of procurement documents.

C.1.6.3.2.2 The employer shall evaluate tenders received during the second stage in terms of the method of evaluation stated in the tender data, and award the contract in terms of these conditions of tender.

C.2 Tenderer's obligations

C.2.1 Eligibility

C.2.1.1 Submit a tender offer only if the tenderer satisfies the criteria stated in the tender data and the tenderer, or any of his principals, is not under any restriction to do business with employer.

C.2.1.2 Notify the employer of any proposed material change in the capabilities or formation of the tendering entity (or both) or any other criteria which formed part of the qualifying



requirements used by the employer as the basis in a prior process to invite the tenderer to submit a tender offer and obtain the employer's written approval to do so prior to the closing time for tenders.

C.2.2 Cost of tendering

C.2.2.1 Accept that, unless otherwise stated in the tender data, the employer will not compensate the tenderer for any costs incurred in the preparation and submission of a tender offer, including the costs of any testing necessary to demonstrate that aspects of the offer complies with requirements.

C.2.2.2 The cost of the tender documents charged by the employer shall be limited to the actual cost incurred by the employer for printing the documents. Employers must attempt to make available the tender documents on its website so as not to incur any costs pertaining to the printing of the tender documents.

C.2.3 Check documents

Check the tender documents on receipt for completeness and notify the employer of any discrepancy or omission.

C.2.4 Confidentiality and copyright of documents

Treat as confidential all matters arising in connection with the tender. Use and copy the documents issued by the employer only for the purpose of preparing and submitting a tender offer in response to the invitation.

C.2.5 Reference documents

Obtain, as necessary for submitting a tender offer, copies of the latest versions of standards, specifications, conditions of contract and other publications, which are not attached but which are incorporated into the tender documents by reference.

C.2.6 Acknowledge addenda

Acknowledge receipt of addenda to the tender documents, which the employer may issue, and if necessary apply for an extension to the closing time stated in the tender data, in order to take the addenda into account.

C.2.7 Clarification meeting

Attend, where required, a clarification meeting at which tenderers may familiarize themselves with aspects of the proposed work, services or supply and raise questions. Details of the meeting(s) are stated in the tender data.

C.2.8 Seek clarification

Request clarification of the tender documents, if necessary, by notifying the employer at least five (5) working days before the closing time stated in the tender data.

C.2.9 Insurance

Be aware that the extent of insurance to be provided by the employer (if any) might not be for the full cover required in terms of the conditions of contract identified in the contract data. The tenderer is advised to seek qualified advice regarding insurance.



C.2.10 Pricing the tender offer

C.2.10.1 Include in the rates, prices, and the tendered total of the prices (if any) all duties, taxes except Value Added Tax (VAT), and other levies payable by the successful tenderer, such duties, taxes and levies being those applicable fourteen (14) days before the closing time stated in the tender data.

C.2.10.2 Show VAT payable by the employer separately as an addition to the tendered total of the prices.

C.2.10.3 Provide rates and prices that are fixed for the duration of the contract and not subject to adjustment except as provided for in the conditions of contract identified in the contract data.

C.2.10.4 State the rates and prices in Rand unless instructed otherwise in the tender data. The conditions of contract identified in the contract data may provide for part payment in other currencies.

C.2.11 Alterations to documents

Do not make any alterations or additions to the tender documents, except to comply with instructions issued by the employer, or necessary to correct errors made by the tenderer. All signatories to the tender offer shall initial all such alterations.

C.2.12 Alternative tender offers

C.2.12.1 Unless otherwise stated in the tender data, submit alternative tender offers only if a main tender offer, strictly in accordance with all the requirements of the tender documents, is also submitted as well as a schedule that compares the requirements of the tender documents with the alternative requirements that are proposed.

C.2.12.2 Accept that an alternative tender offer must be based only on the criteria stated in the tender data or criteria otherwise acceptable to the employer.

C.2.12.3 An alternative tender offer must only be considered if the main tender offer is the winning tender.

C.2.13 Submitting a tender offer

C.2.13.1 Submit one tender offer only, either as a single tendering entity or as a member in a joint venture to provide the whole of the works identified in the contract data and described in the scope of works, unless stated otherwise in the tender data.

C.2.13.2 Return all returnable documents to the employer after completing them in their entirety, either electronically (if they were issued in electronic format) or by writing legibly in non-erasable ink.

C.2.13.3 Submit the parts of the tender offer communicated on paper as an original plus the number of copies stated in the tender data, with an English translation of any documentation in a language other than English, and the parts communicated electronically in the same format as they were issued by the employer.

C.2.13.4 Sign the original and all copies of the tender offer where required in terms of the tender data. The employer will hold all authorized signatories liable on behalf of the tenderer.



Signatories for tenderers proposing to contract as joint ventures shall state which of the signatories is the lead partner whom the employer shall hold liable for the purpose of the tender offer.

C.2.13.5 Seal the original and each copy of the tender offer as separate packages marking the packages as "ORIGINAL" and "COPY". Each package shall state on the outside the employer's address and identification details stated in the tender data, as well as the tenderer's name and contact address.

C.2.13.6 Where a two-envelope system is required in terms of the tender data, place and seal the returnable documents listed in the tender data in an envelope marked "financial proposal" and place the remaining returnable documents in an envelope marked "technical proposal". Each envelope shall state on the outside the employer's address and identification details stated in the tender data, as well as the tenderer's name and contact address.

C.2.13.7 Seal the original tender offer and copy packages together in an outer package that states on the outside only the employer's address and identification details as stated in the tender data.

C.2.13.8 Accept that the employer will not assume any responsibility for the misplacement or premature opening of the tender offer if the outer package is not sealed and marked as stated.

C.2.13.9 Accept that tender offers submitted by facsimile or e-mail will be rejected by the employer, unless stated otherwise in the tender data.

C.2.14 Information and data to be completed in all respects

Accept that tender offers, which do not provide all the data or information requested completely and in the form required, may be regarded by the employer as non-responsive.

C.2.15 Closing time

C.2.15.1 Ensure that the employer receives the tender offer at the address specified in the tender data not later than the closing time stated in the tender data. Accept that proof of posting shall not be accepted as proof of delivery.

C.2.15.2 Accept that, if the employer extends the closing time stated in the tender data for any reason, the requirements of these conditions of tender apply equally to the extended deadline.

C.2.16 Tender offer validity

C.2.16.1 Hold the tender offer(s) valid for acceptance by the employer at any time during the validity period stated in the tender data after the closing time stated in the tender data.

C.2.16.2 If requested by the employer, consider extending the validity period stated in the tender data for an agreed additional period with or without any conditions attached to such extension.

C.2.16.3 Accept that a tender submission that has been submitted to the employer may only be withdrawn or substituted by giving the employer's agent written notice before the closing time for tenders that a tender is to be withdrawn or substituted. If the validity period stated in C.2.16 lapses before the employer evaluating tender, the contractor reserves the right to review the price based on Consumer Price Index (CPI).

C.2.16.4 Where a tender submission is to be substituted, a tenderer must submit a substitute



tender in accordance with the requirements of C.2.13 with the packages clearly marked as "SUBSTITUTE".

C.2.17 Clarification of tender offer after submission

Provide clarification of a tender offer in response to a request to do so from the employer during the evaluation of tender offers. This may include providing a breakdown of rates or prices and correction of arithmetical errors by the adjustment of certain rates or item prices (or both). No change in the competitive position of tenderers or substance of the tender offer is sought, offered, or permitted.

Note: Sub-clause C.2.17 does not preclude the negotiation of the final terms of the contract with a preferred tenderer following a competitive selection process, should the Employer elect to do so.

C.2.18 Provide other material

C.2.18.1 Provide, on request by the employer, any other material that has a bearing on the tender offer, the tenderer's commercial position (including notarized joint venture agreements), preferencing arrangements, or samples of materials, considered necessary by the employer for the purpose of a full and fair risk assessment.

Should the tenderer not provide the material, or a satisfactory reason as to why it cannot be provided, by the time for submission stated in the employer's request, the employer may regard the tender offer as non-responsive.

C.2.18.2 Dispose of samples of materials provided for evaluation by the employer, where required.

C.2.19 Inspections, tests and analysis

Provide access during working hours to premises for inspections, tests and analysis as provided for in the tender data.

C.2.20 Submit securities, bonds and policies

If requested, submit for the employer's acceptance before formation of the contract, all securities, bonds, guarantees, policies and certificates of insurance required in terms of the conditions of contract identified in the contract data.

C.2.21 Check final draft

Check the final draft of the contract provided by the employer within the time available for the employer to issue the contract.

C.2.22 Return of other tender documents

If so instructed by the employer, return all retained tender documents within twenty-eight (28) days after the expiry of the validity period stated in the tender data.

C.2.23 Certificates

Include in the tender submission or provide the employer with any certificates as stated in the tender data.

C.3 The employer's undertakings

C.3.1 Respond to requests from the tenderer

C.3.1.1 Unless otherwise stated in the tender Data, respond to a request for clarification received up to five (5) working days before the tender closing time stated in the Tender Data and notify all tenderers who collected tender documents.

C.3.1.2 Consider any request to make a material change in the capabilities or formation of the tendering entity (or both) or any other criteria which formed part of the qualifying requirements used to prequalify a tenderer to submit a tender offer in terms of a previous procurement process and deny any such request if as a consequence:

- a) an individual firm, or a joint venture as a whole, or any individual member of the joint venture fails to meet any of the collective or individual qualifying requirements;
- b) the new partners to a joint venture were not prequalified in the first instance, either as individual firms or as another joint venture; or
- c) in the opinion of the Employer, acceptance of the material change would compromise the outcome of the prequalification process.

C.3.2 Issue Addenda

If necessary, issue addenda that may amend or amplify the tender documents to each tenderer during the period from the date that tender documents are available until three (3) working days before the tender closing time stated in the Tender Data. If, as a result a tenderer applies for an extension to the closing time stated in the Tender Data, the Employer may grant such extension and, shall then notify all tenderers who collected tender documents.

C.3.3 Return late tender offers

Return tender offers received after the closing time stated in the Tender Data, unopened, (unless it is necessary to open a tender submission to obtain a forwarding address), to the tenderer concerned.

C.3.4 Opening of tender submissions

C.3.4.1 Unless the two-envelope system is to be followed, open valid tender submissions in the presence of tenderers' agents who choose to attend at the time and place stated in the tender data. Tender submissions for which acceptable reasons for withdrawal have been submitted will not be opened.

C.3.4.2 Announce at the meeting held immediately after the opening of tender submissions, at a venue indicated in the tender data, the name of each tenderer whose tender offer is opened and, where

applicable, the total of his prices, number of points claimed for its BBBEE status level and time for completion for the main tender offer only.

C.3.4.3 Make available the record outlined in C.3.4.2 to all interested persons upon request.

C.3.5 Two-envelope system

C.3.5.1 Where stated in the tender data that a two-envelope system is to be followed, open only the technical proposal of valid tenders in the presence of tenderers' agents who choose to attend at the time and place stated in the tender data and announce the name of each tenderer

whose technical proposal is opened.

C.3.5.2 Evaluate functionality of the technical proposals offered by tenderers, then advise tenderers who remain in contention for the award of the contract of the time and place when the financial proposals will be opened. Open only the financial proposals of tenderers, who score in the functionality evaluation more than the minimum number of points for functionality stated in the tender data, and announce the score obtained for the technical proposals and the total price and any points claimed on BBBEE status level. Return unopened financial proposals to tenderers whose technical proposals failed to achieve the minimum number of points for functionality.

C.3.6 Non-disclosure

Not disclose to tenderers, or to any other person not officially concerned with such processes, information relating to the evaluation and comparison of tender offers, the final evaluation price and recommendations for the award of a contract, until after the award of the contract to the successful tenderer.

C.3.7 Grounds for rejection and disqualification

Determine whether there has been any effort by a tenderer to influence the processing of tender offers and instantly disqualify a tenderer (and his tender offer) if it is established that he engaged in corrupt or fraudulent practices.

C.3.8 Test for responsiveness

C.3.8.1 Determine, after opening and before detailed evaluation, whether each tender offer properly received:

- a) complies with the requirements of these Conditions of Tender,
- b) has been properly and fully completed and signed, and
- c) is responsive to the other requirements of the tender documents.

C.3.8.2 A responsive tender is one that conforms to all the terms, conditions, and specifications of the tender documents without material deviation or qualification. A material deviation or qualification is one which, in the Employer's opinion, would:

- a) detrimentally affect the scope, quality, or performance of the works, services or supply identified in the Scope of Work,
- b) significantly change the Employer's or the tenderer's risks and responsibilities under the contract, or
- c) affect the competitive position of other tenderers presenting responsive tenders, if it were to be rectified.

Reject a non-responsive tender offer, and not allow it to be subsequently made responsive by correction or withdrawal of the non-conforming deviation or reservation.

C.3.9 Arithmetical errors, omissions and discrepancies

C.3.9.1 Check responsive tenders for discrepancies between amounts in words and amounts in figures. Where there is a discrepancy between the amounts in figures and the amount in words, the amount in words shall govern.

C.3.9.2 Check the highest ranked tender or tenderer with the highest number of tender



evaluation points after the evaluation of tender offers in accordance with C.3.11 for:

- a) the gross misplacement of the decimal point in any unit rate;
- b) omissions made in completing the pricing schedule or bills of quantities; or
- c) arithmetic errors in:
 - (i) line item totals resulting from the product of a unit rate and a quantity in bills of quantities or schedules of prices; or
 - (ii) the summation of the prices.

C.3.9.3 Notify the tenderer of all errors or omissions that are identified in the tender offer and either confirm the tender offer as tendered or accept the corrected total of prices.

C.3.9.4 Where the tenderer elects to confirm the tender offer as tendered, correct the errors as follows:

- a) If bills of quantities or pricing schedules apply and there is an error in the line item total resulting from the product of the unit rate and the quantity, the line item total shall govern and the rate shall be corrected. Where there is an obviously gross misplacement of the decimal point in the unit rate, the line item total as quoted shall govern, and the unit rate shall be corrected.
- b) Where there is an error in the total of the prices either as a result of other corrections required by this checking process or in the tenderer's addition of prices, the total of the prices shall govern and the tenderer will be asked to revise selected item prices (and their rates if bills of quantities apply) to achieve the tendered total of the prices.

C.3.10 Clarification of a tender offer

Obtain clarification from a tenderer on any matter that could give rise to ambiguity in a contract arising from the tender offer.

C.3.11 Evaluation of tender offers

The Standard Conditions of Tender standardize the procurement processes, methods and procedures from the time that tenders are invited to the time that a contract is awarded. They are generic in nature and are made project specific through choices that are made in developing the Tender Data associated with a specific project.

Conditions of tender are by definition the document that establishes a tenderer's obligations in submitting a tender and the employer's undertakings in soliciting and evaluating tender offers. Such conditions establish the rules from the time a tender is advertised to the time that a contract is awarded and require employers to conduct the process of offer and acceptance in terms of a set of standard procedures.

The CIDB Standard Conditions of Tender are based on a procurement system that satisfies the following system requirements:	
Requirement	Qualitative interpretation of goal
Fair	The process of offer and acceptance is conducted impartially without bias, providing simultaneous and timely access to participating parties to the same information.
Equitable	Terms and conditions for performing the work do not unfairly prejudice the interests of the parties.
Transparent	The only grounds for not awarding a contract to a tenderer who satisfies all requirements are restrictions from doing business with the employer, lack of capability or capacity, legal impediments and conflicts of

	interest.
Competitive	The system provides for appropriate levels of competition to ensure cost effective and best value outcomes.
Cost effective	The processes, procedures and methods are standardized with sufficient flexibility to attain best value outcomes in respect of quality, timing and price, and least resources to effectively manage and control procurement processes.

The activities associated with evaluating tender offers are as follows:

- a) Open and record tender offers received
- b) Determine whether or not tender offers are complete
- c) Determine whether or not tender offers are responsive
- d) Evaluate tender offers
- e) Determine if there are any grounds for disqualification
- f) Determine acceptability of preferred tenderer
- g) Prepare a tender evaluation report
- h) Confirm the recommendation contained in the tender evaluation report

C.3.11.1 General

The employer must appoint an evaluation panel of not less than three persons conversant with the proposed scope of works to evaluate each responsive tender offer using the tender evaluation methods and associated evaluation criteria and weightings that are specified in the tender data.

C.3.12 Insurance provided by the employer

If requested by the proposed successful tenderer, submit for the tenderer's information the policies and / or certificates of insurance which the conditions of contract identified in the contract data, require the employer to provide.

C.3.13 Acceptance of tender offer

Accept the tender offer; if in the opinion of the employer, it does not present any risk and only if the tenderer:

- a) is not under restrictions, or has principals who are under restrictions, preventing participating in the employer's procurement;
- b) can, as necessary and in relation to the proposed contract, demonstrate that he or she possesses the professional and technical qualifications, professional and technical competence, financial resources, equipment and other physical facilities, managerial capability, reliability, experience and reputation, expertise and the personnel, to perform the contract;
- c) has the legal capacity to enter into the contract;
- d) is not; insolvent, in receivership, under Business Rescue as provided for in chapter 6 of the Companies Act No. 2008, bankrupt or being wound up, has his/her affairs administered by a court or a judicial officer, has suspended his/her business activities or is subject to legal proceedings in respect of any of the foregoing;
- e) complies with the legal requirements, if any, stated in the tender data; and
- f) is able, in the opinion of the employer, to perform the contract free



of conflicts of interest.

C.3.14 Prepare contract documents

C.3.14.1 If necessary, revise documents that shall form part of the contract and that were issued by the employer as part of the tender documents to take account of:

- a) addenda issued during the tender period,
- b) inclusion of some of the returnable documents and
- c) other revisions agreed between the employer and the successful tenderer.

C.3.14.2 Complete the schedule of deviations attached to the form of offer and acceptance, if any.

C.3.15 Complete adjudicator's contract

Unless alternative arrangements have been agreed or otherwise provided for in the contract, arrange for both parties to complete formalities for appointing the selected adjudicator at the same time as the main contract is signed.

C.3.16 Registration of the award

An employer must, within twenty-one (21) working days from the date on which a contractor's offer to perform a construction works contract is accepted in writing by the employer, register and publish the award on the cidb Register of Projects.

C.3.17 Provide copies of the contracts

Provide to the successful tenderer the number of copies stated in the Tender Data of the signed copy of the contract as soon as possible after completion and signing of the form of offer and acceptance.

C.3.18 Provide written reasons for actions taken

Provide upon request written reasons to tenderers for any action that is taken in applying these conditions of tender but withhold information which is not in the public interest to be divulged, which is considered to prejudice the legitimate commercial interests of tenderers or might prejudice fair competition between tenderers.



AIRPORTS COMPANY SOUTH AFRICA

AIRPORT: King Shaka International Airport

BID REF. No: KSIA7227/203/RFP

TITLE: CONTRACTOR APPOINTMENT FOR THE ONCE OFF REPLACEMENT OF SUBMERSIBLE PUMPS AT KING SHAKA INTERNATIONAL AIRPORT.

Part T2: Returnable Documents

T2.1: List of Returnable Document

T2.2: Returnable Schedules

AIRPORTS COMPANY SOUTH AFRICA

AIRPORT: King Shaka International Airport

BID REF. No: KSIA7227/2023/RFP

TITLE CONTRACTOR APPOINTMENT FOR THE ONCE OFF REPLACEMENT OF SUBMERSIBLE PUMPS AT KING SHAKA INTERNATIONAL AIRPORT.

T2.1: LIST OF RETURNABLE DOCUMENTS

The tenderer must complete the following returnable documents:		Completed (tick)
1	Returnable Schedules required for tender evaluation purposes only	
	A1: Certificate of Attendance at Non-Compulsory Briefing session	
	A2: Record of Addenda to Tender Documents	
	A3: Certificate of Authority for Signatory	
	A4: Certificate of Authority for Joint Ventures (<i>where applicable</i>)	
	A5: Schedule of the Tenderer's Recent Experience related to this Project	
	A6: Completion Certificates of Previous Projects Completed	
	A7: Certified Copies of Client Reference Letters of Previous Projects Completed	
	A8: Proof of Contract Values of Previous Projects Completed	
	A9: Schedule of Current Commitments	
	A10: SBD 4: Bidder's Disclosure Form	
	A11: SBD 6.1: Preference points claim form in terms of preferential procurement Regulations	
	A12: SBD 6.2 Declaration for local content and production for PPPFA designated sectors (<i>if applicable</i>)	
	A13: Confidentiality and Non-Disclosure Agreement.	
2	Other documents required only for tender evaluation purposes	
	B1: Proof of registration for Contractor's WCA registration and or COID	
	B2: A certified copy of Certificate of Contractor Registration issued by the Construction Industry Development Board (CIDB)	
	B3: SARS Pin issued by the South African Revenue Services.	
	B4: An original Bank Statement of good financial standing (Bank Rating) for the tender sum	
	B5: Central Supplier Database (CSD) proof of registration.	
3	Returnable Schedules required for tender evaluation purposes that will be incorporated into the contract	
	C1.1 Form of Offer and Acceptance (Contract part)	
	C1: Compulsory Enterprise Questionnaire	



The tenderer must complete the following returnable documents:	<u>Completed</u> <u>(tick)</u>
C2: Schedule of Proposed Subcontractors	
C4: Subcontractor’s Supporting Documents	
C5: Plant and Equipment	
C6: A certified copy of B-BBEE Verification Certificate	
C7: CV’s of key personnel	
C8: Certified Certificates of Qualifications of Key Personnel.	
C9 Work Plan and Proposed Methodology	
C10 Occupational Health and Safety Questionnaire	
C11 Schedule of Information to be provided by Tenderer	
C12 Proposed Amendments and Qualifications	

T2.2: RETURNABLE SCHEDULES

FORM A1. Certificate of Attendance of the Non-Compulsory Briefing Session

This is to certify that

I,

Representative of (tenderer).....

.....

of (address).....

.....

.....

e-mail

telephone number

fax number.....

visited the compulsory brief session held on date.....

Signed		Date	18/04/2024
Name		Position	



Tenderer	
----------	--

Signed by ACSA
Representative:

18/04/2024

Name: Johnson Mji

FORM A2. Record of Addenda to Tender Documents

We confirm that the following communications received from the Employer before the submission of this response for Tenders, amending the Tenders documents, have been taken into account in this response:

	Date	Title or Details
1.		
2.		
3.		
4.		
5.		
6.		
7.		
8.		
9.		
10.		



Attach additional pages if more space is required.

Signed		Date	
Name		Position	
Tenderer			

Form A3: Certificate of Authority for Signatory

- (1) Signatories for close corporations and companies shall confirm their authority by attaching to this form a duly signed and dated copy of the relevant resolution of their members or their board of directors, as the case may be.
- (2) In the event that the tenderer is a joint venture, a certificate of authority for signatories (Form A3) is required from all members of the joint venture and the designated lead member shall be clearly identified as requested by tender condition C2.13.4.

An example is shown below:

"By resolution of the board of directors taken on 20.....

Mr/Ms

whose signature appear below, has been duly authorized to sign all documents in connection with this tender for Tender number KSIA7227/2023/RFP and any contract which may arise there from on behalf of

(block capitals)

Signed on behalf of Company:

In his/her capacity as:

Date:..... Signatory of Authority:

Witnesses:

.....
Signature

.....
Signature

.....
Name (print)

.....
Name (print)



Attach: <ul style="list-style-type: none"> ▪ Latest Audited Annual Financial Report (If applicable) ▪ Bank reference Letter
--

Signed		Date	
Name		Position	
Tenderer			

FORM A4. Certificate of Authority of Joint Ventures (where applicable)

This Returnable Schedule is to be completed by joint ventures.

We, the undersigned, are submitting this tender offer in Joint Venture and hereby authorise Mr/Ms , authorised signatory of the company , acting in the capacity of lead partner, to sign all documents in connection with the tender offer and any contract resulting from it on our behalf.

Please attach JV agreement stipulation % share of each JV

NAME OF FIRM	ADDRESS	DULY AUTHORISED SIGNATORY
Lead partner		Signature: Name: Designation:
		Signature: Name: Designation:
		Signature: Name: Designation:

Signed		Date	
--------	--	------	--



Name		Position	
Tenderer			

FORM A5. Schedule of the Tenderer’s Recent Experience

The experience of the tenderer or joint venture partners in the case of an unincorporated joint venture or consortium as opposed to the key staff members / experts in similar projects or similar areas and conditions in relation to the scope of work over the last **xx years**.

Bidders are requested to submit a comprehensive portfolio of relevant (value and complexity) projects successfully completed.

As a minimum the bidder is to have successfully completed at least **xxxx** each project with contract value of **RXX million (inclusive of VAT)** or more to achieve a satisfactory score.

Bidders should very briefly describe his or her experience in this regard and attach this to this schedule. See format below

The description should be put in tabular form with the following headings:

Employer, contact person and telephone number	Principal Agent (Name, Tel No, Contact Person)	Description of works/ Project Name	Value of work inclusive of VAT (Rand)	Date started	Date completed	COMPLETION CERTIFICATE OR CLIENT REFERENCE LETTER	
						YES	NO



Note: When completing the above schedule, Tenderer's must take cognisance of the evaluation criteria as described in the Tender Data, Part T1.2, Clause C.3.11

The undersigned, who warrants that he / she is duly authorized to do so on behalf of the enterprise, confirms that the contents of this schedule are within my personal knowledge and are to the best of my belief both true and correct.

Signed		Date	
Name		Position	
Tenderer			



FORM A6 Certified Copies of Completion Certificates of Previous Projects Completed

Please attach Completion Certificates (Practical Completion) of Previous Projects Completed as listed under Form A5 above to this page.

A minimum of three (3) certificates required for relevant projects

The undersigned, who warrants that he / she is duly authorized to do so on behalf of the enterprise, confirms that the contents of this schedule are within my personal knowledge and are to the best of my belief both true and correct.

Signed		Date	
--------	--	------	--



Name		Position	
Tenderer			

FORM A7 Certified Copies of Client Reference Letters of Previous Projects Completed

Please attach certified copies of Client Reference Letters of Previous Projects Completed as listed under Form A5 above to this page.
A minimum of three (3) reference letters required from the client bodies/Principal Agent.

The undersigned, who warrants that he / she is duly authorized to do so on behalf of the enterprise, confirms that the contents of this schedule are within my personal knowledge and are to the best of my belief both true and correct.



Signed		Date	
Name		Position	
Tenderer			

Form A8 Proof of Contract Values of Previous Projects Completed

Please attach proof of Contract Values of Previous Projects Completed as listed under Form A5 above to this page. A minimum of three (3) certificates required for relevant projects

The undersigned, who warrants that he / she is duly authorized to do so on behalf of the enterprise, confirms that the contents of this schedule are within my personal knowledge and are to the best of my belief both true and correct.

Signed		Date	
--------	--	------	--



Name		Position	
Tenderer			

Form A9: Schedule of Current Commitments

1. The tenderer shall list below all projects with which the proposed key personnel are currently involved.
2. In the event of a joint venture enterprise, details of all the members of the joint venture shall similarly be attached to this form.

Employer, contact person and telephone number	Consultant/ Principal Agent, contact person and telephone number	Description of contract	Value of work inclusive of VAT (rand)	Completion Date



Signed		Date	
Name		Position	
Tenderer			

SBD 4

A10. BIDDER’S DISCLOSURE

1. PURPOSE OF THE FORM

Any person (natural or juristic) may make an offer or offers in terms of this invitation to bid. In line with the principles of transparency, accountability, impartiality, and ethics as enshrined in the Constitution of the Republic of South Africa and further expressed in various pieces of legislation, it is required for the bidder to make this declaration in respect of the details required hereunder.

Where a person/s are listed in the Register for Tender Defaulters and / or the List of Restricted Suppliers, that person will automatically be disqualified from the bid process.

2. Bidder’s declaration

2.1 Is the bidder, or any of its directors / trustees / shareholders / members / partners or any person having a controlling interest¹ in the enterprise, employed by the state? **YES/NO**

2.1.1 If so, furnish particulars of the names, individual identity numbers, and, if applicable, state employee numbers of sole proprietor/ directors / trustees / shareholders / members/ partners or any person having a controlling interest in the enterprise, in table below.

Full Name	Identity Number	Name of State institution

¹ the power, by one person or a group of persons holding the majority of the equity of an enterprise, alternatively, the person/s having the deciding vote or power to influence or to direct the course and decisions of the enterprise.



2.2 Do you, or any person connected with the bidder, have a relationship with any person who is employed by the procuring institution? **YES/NO**

2.2.1 If so, furnish particulars:

.....
.....

2.3 Does the bidder or any of its directors / trustees / shareholders / members / partners or any person having a controlling interest in the enterprise have any interest in any other related enterprise whether or not they are bidding for this contract? **YES/NO**

2.3.1 If so, furnish particulars:

.....
.....

3 DECLARATION

I, the undersigned, (name)..... in submitting the accompanying bid, do hereby make the following statements that I certify to be true and complete in every respect:

- 3.1 I have read and I understand the contents of this disclosure;
- 3.2 I understand that the accompanying bid will be disqualified if this disclosure is found not to be true and complete in every respect;
- 3.3 The bidder has arrived at the accompanying bid independently from, and without consultation, communication, agreement or arrangement with any competitor. However, communication between partners in a joint venture or consortium² will not be construed as collusive bidding.
- 3.4 In addition, there have been no consultations, communications, agreements or arrangements with any competitor regarding the quality, quantity, specifications, prices, including methods, factors or formulas used to calculate prices, market allocation, the intention or decision to submit or not to submit the bid, bidding with the intention not to win the bid and conditions or delivery particulars of the products or services to which this bid invitation relates.
- 3.4 The terms of the accompanying bid have not been, and will not be, disclosed by the bidder, directly or indirectly, to any competitor, prior to the date and time of the official bid opening or of the awarding of the contract.
- 3.5 There have been no consultations, communications, agreements or arrangements made by the bidder with any official of the procuring institution in relation to this procurement process prior to and during the bidding process except to provide clarification on the bid submitted where so required by the institution; and the bidder was not involved in the drafting of the specifications or terms of reference for this bid.
- 3.6 I am aware that, in addition and without prejudice to any other remedy provided to combat any restrictive practices related to bids and contracts, bids that are suspicious will be reported to the Competition Commission for investigation and possible imposition of administrative penalties in terms of section 59 of the Competition Act No 89 of 1998 and or may be reported to the National Prosecuting Authority (NPA) for criminal investigation and or may be restricted from conducting business with the public sector for a period not exceeding ten (10) years in terms of the Prevention and Combating of Corrupt Activities Act No 12 of 2004 or any other applicable legislation.

² Joint venture or Consortium means an association of persons for the purpose of combining their expertise, property, capital, efforts, skill and knowledge in an activity for the execution of a contract.



I CERTIFY THAT THE INFORMATION FURNISHED IN PARAGRAPHS 1, 2 and 3 ABOVE IS CORRECT.

I ACCEPT THAT THE STATE MAY REJECT THE BID OR ACT AGAINST ME IN TERMS OF PARAGRAPH 6 OF PFMA SCM INSTRUCTION 03 OF 2021/22 ON PREVENTING AND COMBATING ABUSE IN THE SUPPLY CHAIN MANAGEMENT SYSTEM SHOULD THIS DECLARATION PROVE TO BE FALSE.

.....
Signature

.....
Date

.....
Position

.....
Name of bidder

SBD 6.1

A11. PREFERENCE POINTS CLAIM FORM IN TERMS OF THE PREFERENTIAL PROCUREMENT REGULATIONS 2022 SBD 6.1

This preference form must form part of all tenders invited. It contains general information and serves as a claim form for preference points for specific goals.

NB: BEFORE COMPLETING THIS FORM, TENDERERS MUST STUDY THE GENERAL CONDITIONS, DEFINITIONS AND DIRECTIVES APPLICABLE IN RESPECT OF THE TENDER AND PREFERENTIAL PROCUREMENT REGULATIONS, 2022

1. GENERAL CONDITIONS

1.1 The following preference point systems are applicable to invitations to tender:

- the 80/20 system for requirements with a Rand value of up to R50 000 000 (all applicable taxes included); and

1.2 To be completed by the organ of state

- a) The applicable preference point system for this tender is the 80/20 preference point system.
- b) The 80/20 preference point system will be applicable in this tender.

1.3 Points for this tender (even in the case of a tender for income-generating contracts) shall be awarded for:

- (a) Price; and
- (b) Specific Goals / Preference .

1.4 To be completed by the organ of state:



The maximum points for this tender are allocated as follows:

	POINTS
PRICE	80
SPECIFIC GOALS / PREFERENCE	20
Total points for Price and SPECIFIC GOALS	100

- 1.5 Failure on the part of a tenderer to submit proof or documentation required in terms of this tender to claim points for specific goals with the tender, will be interpreted to mean that preference points for specific goals are not claimed.
- 1.6 The organ of state reserves the right to require of a tenderer, either before a tender is adjudicated or at any time subsequently, to substantiate any claim in regard to preferences, in any manner required by the organ of state.

2. DEFINITIONS

- (a) **“tender”** means a written offer in the form determined by an organ of state in response to an invitation to provide goods or services through price quotations, competitive tendering process or any other method envisaged in legislation;
- (b) **“price”** means an amount of money tendered for goods or services, and includes all applicable taxes less all unconditional discounts;
- (c) **“rand value”** means the total estimated value of a contract in Rand, calculated at the time of bid invitation, and includes all applicable taxes;
- (d) **“tender for income-generating contracts”** means a written offer in the form determined by an organ of state in response to an invitation for the origination of income-generating contracts through any method envisaged in legislation that will result in a legal agreement between the organ of state and a third party that produces revenue for the organ of state, and includes, but is not limited to, leasing and disposal of assets and concession contracts, excluding direct sales and disposal of assets through public auctions; and
- (e) **“the Act”** means the Preferential Procurement Policy Framework Act, 2000 (Act No. 5 of 2000).

3. FORMULAE FOR PROCUREMENT OF GOODS AND SERVICES

3.1. POINTS AWARDED FOR PRICE

3.1.1 THE 80/20 PREFERENCE POINT SYSTEMS

A maximum of 80 points is allocated for price on the following basis:

80/20

$$Ps = 80 \left(1 - \frac{Pt - P_{min}}{P_{min}} \right)$$

Where



- Ps = Points scored for price of tender under consideration
- Pt = Price of tender under consideration
- Pmin = Price of lowest acceptable tender

4. POINTS AWARDED FOR SPECIFIC GOALS

- 4.1. In terms of Regulation 4(2); 5(2); 6(2) and 7(2) of the Preferential Procurement Regulations, preference points must be awarded for specific goals stated in the tender. For the purposes of this tender the tenderer will be allocated points based on the goals stated in table 1 below as may be supported by proof/ documentation stated in the conditions of this tender:
- 4.2. In cases where organs of state intend to use Regulation 3(2) of the Regulations, which states that, if it is unclear whether the 80/20 preference point system applies, an organ of state must, in the tender documents, stipulate in the case of—
 - (a) an invitation for tender for income-generating contracts, that the 80/20 preference point system will apply and that the highest acceptable tender will be used to determine the applicable preference point system; or
 - (b) any other invitation for tender, that either the 80/20 preference point system will apply and that the lowest acceptable tender will be used to determine the applicable preference point system,
 then the organ of state must indicate the points allocated for specific goals for the 80/20 preference point system.

Table 1: Specific goals for the tender and points claimed are indicated per the table below.

Note to tenderers: The tenderer must indicate how they claim points for each preference point system.)

The specific goals/preference point allocated points in terms of this tender	Number of points allocated (80/20 system) (To be completed by the organ of state)	Number of points claimed (80/20 system) (To be completed by the tenderer)
--	--	--



51% owned by Black male and/or Black women and Black youth and People living with disabilities	20	
51% owned by Black male or Black women or Black youth or People living with disabilities (at least two of the above designated groups must achieved)	15	
51% owned by Black male or Black women or Black youth or People living with disabilities	10	
Less than 51% owned by Black male, Black women, Black youth, People living with disabilities	5	
Other	0	

DECLARATION WITH REGARD TO COMPANY/FIRM

4.3. Name of company/firm.....

4.4. Company registration number:

4.5. TYPE OF COMPANY/ FIRM

- Partnership/Joint Venture / Consortium
 - One-person business/sole propriety
 - Close corporation
 - Public Company
 - Personal Liability Company
 - (Pty) Limited
 - Non-Profit Company
 - State Owned Company
- [TICK APPLICABLE BOX]

4.6. I, the undersigned, who is duly authorised to do so on behalf of the company/firm, certify that the points claimed, based on the specific goals as advised in the tender, qualifies the company/ firm for the preference(s) shown and I acknowledge that:

- i) The information furnished is true and correct;
- ii) The preference points claimed are in accordance with the General Conditions as indicated in paragraph 1 of this form;
- iii) In the event of a contract being awarded as a result of points claimed as shown in paragraphs 1.4 and 4.2, the contractor may be required to furnish documentary proof to the satisfaction of the organ of state that the claims are correct;
- iv) If the specific goals have been claimed or obtained on a fraudulent basis or any of the conditions of contract have not been fulfilled, the organ of state may, in addition to any



other remedy it may have –

- (a) disqualify the person from the tendering process;
- (b) recover costs, losses or damages it has incurred or suffered as a result of that person’s conduct;
- (c) cancel the contract and claim any damages which it has suffered as a result of having to make less favourable arrangements due to such cancellation;
- (d) recommend that the tenderer or contractor, its shareholders and directors, or only the shareholders and directors who acted on a fraudulent basis, be restricted from obtaining business from any organ of state for a period not exceeding 10 years, after the *audi alteram partem* (hear the other side) rule has been applied; and
- (e) forward the matter for criminal prosecution, if deemed necessary.

 SIGNATURE(S) OF TENDERER(S)
SURNAME AND NAME:
DATE:
ADDRESS:

Form A13: CONFIDENTIALITY AND NON-DISCLOSURE AGREEMENT

Between

AIRPORTS COMPANY SOUTH AFRICA SOC LIMITED
(Registration No. 1993/004149/30)
("Airports Company")

of



Western Precinct, Aviation Park
O.R. Tambo International Airport
1 Jones Road
Kempton Park
1632

AND

[NAME OF SERVICE PROVIDER]
(Registration No: _____)
("_____")

of

[Service Providers Address]

1. **INTERPRETATION**

In this agreement -

- 1.1 "confidential Information" – is information which is confidential to the disclosing party, and includes whether in written, graphic, oral, proprietary, tangible, intangible, electronic or other form, and, -
 - 1.1.1 any information in respect of know-how, formulae, statistics, processes, systems, business methods, marketing, trading and merchandising methods and information, promotional and advertising plans and strategies, pricing, financial plans and models, inventions, long-term plans, research and development data, user or consumer/customer data and profiles, ideas, computer programmes, drawings and any other information of an confidential nature of the disclosing party, in whatever form it may be;
 - 1.1.2 the contractual business and financial arrangements of the disclosing party and others with whom it has business arrangements of whatever nature;
 - 1.1.3 all information peculiar to the business of the disclosing party which is not readily available to a competitor of the disclosing party in the ordinary course of business;
 - 1.1.4 the fact of and content of any discussions between the disclosing party and the receiving party as well as the existence and content of any agreement, which may be concluded between the disclosing party and the receiving party;
 - 1.1.5 all other matters of a confidential nature which relate to the disclosing party's business;
 - 1.1.6 generally, information which is disclosed in circumstances of confidence or would be understood by the parties, exercising reasonable business judgement, to be confidential;
 - 1.1.7 all information of whatsoever nature relating to the disclosing party as contemplated in 2.1 below;

but does not include information which -

 - 1.1.8 is or hereafter becomes part of the public domain, otherwise than as a result of a breach or default of the receiving party or of a representative or affiliate of the receiving party;



- 1.1.9 can be shown to have been lawfully in the possession of the receiving party or its affiliates or consultants prior to its disclosure and is not subject to an existing agreement between the disclosing party and the receiving party;
- 1.1.10 is acquired by the receiving party independently from a third party who lawfully acquired such information without restriction and who had not previously obtained the confidential information directly or indirectly under a confidentiality obligation from the disclosing party;
- 1.1.11 is acquired or developed by the receiving party independently of the disclosing party and in circumstances which do not amount to a breach of the provisions of this agreement;
- 1.1.12 is disclosed or released by the receiving party to satisfy an order of a court of competent jurisdiction or to otherwise comply with the provisions of any law or regulation in force at the time or the requirements of any recognised stock exchange; provided that, in these circumstances, the receiving party shall inform the disclosing party of the requirement to disclose prior to making the disclosure and provided further that the receiving party will disclose only that portion of the confidential information which it is legally required to so disclose; and the receiving party will use its reasonable endeavours to protect the confidentiality of such information to the widest extent lawfully possible in the circumstances (and shall co-operate with the disclosing party if it elects to contest any such disclosure);
- 1.2 For the purposes of this agreement the party, which discloses confidential information, shall be referred to as “the disclosing party” and the party, which receives the confidential information, shall be referred to as “the receiving party”.
- 1.3 ““affiliate” –of a Party means any person, now or hereafter existing, who directly or indirectly controls, (*holding company*) or is controlled or is under common control of such Party (subsidiary company); a Person “controls” another person if it holds or is beneficially entitled to hold , directly or indirectly, other than by way of security interest only, more than 50% of its voting , income or capital;
- 1.4 “disclosing party” – the party disclosing confidential information in terms of this agreement and being Airports Company;
- 1.5 “receiving party” – the party receiving confidential information in terms of this agreement;
- 1.6 “the parties” – the Airports Company and _____.

2. **INTRODUCTION**

- 2.1 The parties intend to provide each other with certain information pertaining to their operations and the parties are in the process of discussing certain matters with a view to concluding an agreement (“the potential agreement”), which discussions have required and will require the disclosure to one another of information of a proprietary, secret and confidential nature. Whether or not the parties conclude the potential agreement will not affect the validity of this agreement.
- 2.2 If the confidential information so disclosed is used by the receiving party for any purpose other than that for which its use is authorised in terms of this agreement or is disclosed or disseminated by the receiving party to another person or entity which is not a party to this agreement, this may cause the disclosing party to suffer damages and material financial loss.



- 2.3 This agreement shall also bind the parties, notwithstanding the date of signature hereof, in the event that either party shall have disclosed any confidential information to the other party prior to date of signature hereof.
- 2.4 The parties wish to record the terms and conditions upon which each shall disclose confidential information to the other, which terms and conditions shall constitute a binding and enforceable agreement between the parties and their agents.

3. **USE OF CONFIDENTIAL INFORMATION**

Any confidential information disclosed by the disclosing party shall be received and used by the receiving party only for the limited purpose described in 2.1 above and for no other purpose.

4. **NON-DISCLOSURE**

4.1 THE RECEIVING PARTY undertakes that -

- 4.1.1 it will treat the disclosing party's confidential information as private and confidential and safeguard it accordingly;
- 4.1.2 it will not use (except as permitted in 3 above) or disclose or release or copy or reproduce or publish or circulate or reverse or engineer and/or decompile or otherwise transfer, whether directly or indirectly, the confidential information of the disclosing party to any other person or entity; and the receiving party shall take all such steps as may be reasonably necessary to prevent the disclosing party's confidential information falling into the hands of unauthorised persons or entities;
- 4.1.3 it shall not disclose the confidential information of the disclosing party to any employee, consultant, professional adviser, contractor or sub-contractor or agent of the receiving party (collectively referred to herein as "representative") or an affiliate of the receiving party, nor shall they be given access thereto by the receiving party -
- 4.1.3.1 unless it is strictly necessary for the purposes referred to in 2.1 above; and
- 4.1.3.2 the receiving party shall have procured that the representative, affiliate or consultant to whom or to which such information is disclosed or made available shall have agreed to be bound by all the terms of this agreement, and, in such event, the receiving party hereby indemnifies the disclosing party against any loss, harm or damage which it may suffer as a result of the unauthorised disclosure of confidential information by a representative, affiliate or consultant.

- 4.2 Any documentation or written record or other material containing confidential information (in whatsoever form) which comes into the possession of the receiving party shall itself be deemed to form part of the confidential information of the disclosing party. The receiving party shall, on request, and in any event if the discussions referred to in 2.1 above should not result in an agreement, return to the disclosing party all of its confidential information which is in physical form (including all copies) and shall destroy any other records (including, without limitation, those in machine readable form) as far as they contain the disclosing party's confidential information. The receiving party will, upon written or oral request from the disclosing party and within five (5) business days of the disclosing party's request, provide the disclosing party with written confirmation that all such records have been destroyed.

5. **COPIES**

- 5.1 The receiving party may only make such copies of the disclosing party's confidential information as are strictly necessary for the purpose and the disclosures which are not in breach of this



agreement and authorised in terms of this agreement. The receiving party shall clearly mark all such copies as “Confidential”.

- 5.2 At the written request of the disclosing party, the receiving party shall supply to the disclosing party a list showing, to the extent practical –
- 5.2.1 where copies of the confidential Information are held;
 - 5.2.2 copies that have been made by the receiving party (except where they contain insignificant extracts from or references to confidential information) and where they are held; and
 - 5.2.3 the names and addresses of the persons to whom confidential information has been disclosed and, if applicable, a copy of the confidentiality undertaking signed by such persons complying with the provisions of this agreement.

6. **THE USE OF THE COMPANY’S INTELLECTUAL PROPERTY**

- 6.1 The receiving party shall not use any intellectual property of the Company (including trademarks, service marks, logos, slogans, trade names, brand names and other indicia of origin) (collectively, the “**Company IP**”) for any reason whatsoever without first obtaining the Company’s prior written consent which consent the Company shall be entitled to grant solely at its own discretion.
- 6.2 If the receiving party requires the use of such Company IP, a request must be sent to the Brand Custodians Office, via email to brandcustodian@airports.co.za. Each single request by the same receiving party shall be treated as a new request.
- 6.3 Should the Company provide its consent in terms of clause 6.1 above, the receiving party shall comply with the Company’s policies and standards with regard to the use of the Company IP. Such policies and standards shall be communicated to the receiving party at the time the Company grants the consent to the receiving party.
- 6.4 Failure to adhere to the provisions of this clause 6 or the policies, brand requirements and protocols that will be communicated by the Brand Custodians Office to the receiving party, shall result in the penalty equal to the value of 2% (two per cent) of the receiving party’s annual turnover in the financial year in which the aforesaid failure occurred.

7. **DURATION**

- 7.1 Subject to Clause 2.3 this agreement shall commence or shall be deemed to have commenced on the date of signature of this agreement by the last party to sign the agreement.
- 7.2 This agreement shall remain in force for a period of **5** years (“the term”), or for a period of one (1) year from the date of the last disclosure of confidential information to the receiving party, whichever is the longer period, whether or not the parties continue to have any relationship for that period of time.

8. **Title**

- 8.1 All confidential information disclosed by the disclosing party to the receiving party is acknowledged by the receiving party:
- 8.1.1 to be proprietary to the disclosing party; and
 - 8.1.2 not to confer any rights to the receiving party of whatever nature in the confidential information.

9. **RELATIONSHIP BETWEEN THE PARTIES**

- 9.1 The disclosing party is not obliged, by reason of this agreement, to disclose any of its confidential information to the receiving party or to enter into any further agreement or business relationship with the receiving party. Nothing herein shall imply or create any exclusive relationship between the Parties or otherwise restrict either Party from pursuing any



business opportunities provided it complies at all times with the non-disclosure obligations set forth herein

9.2 The disclosing party retains the sole and exclusive ownership of intellectual property rights to its confidential information and no license or any other interest in such confidential information is granted in terms hereof or by reason of its disclosure.

9.3 The termination of the discussions referred to in 2.1 above shall not release the parties from the obligations set out in this agreement.

10. **ENFORCEMENT, GOVERNING LAWS AND JURISDICTION**

10.1 This agreement shall be governed by and interpreted according to the laws of the Republic of South Africa, without reference to the choice of laws' provisions of the Republic of South Africa. In the event of a conflict between or inconsistency in the laws applicable in the various provinces of the Republic of South Africa, the law as applied and interpreted in the Gauteng Province shall prevail.

10.2 The parties irrevocably submit to the exclusive jurisdiction of the High Court of South Africa, Witwatersrand Local Division, in respect of any action or proceeding arising from this agreement.

10.3 The parties agree that, in the event of a breach of this agreement, monetary damages would not be an adequate remedy. In the event of a breach or threatened breach of any provisions of this agreement by the receiving party, the disclosing party (and/or its relevant affiliate) shall be entitled to injunctive relief in any court of competent jurisdiction and the receiving party shall reimburse the disclosing party for any costs, claims, demands or liabilities arising directly or indirectly out of a breach. Nothing contained in this agreement shall be construed as prohibiting a party or its affiliate from pursuing any other remedies available to it for a breach or threatened breach.

10.4 The failure by the disclosing party to enforce or to require the performance at any time of any of the provisions of this agreement shall not be construed to be a waiver of such provision, and shall not affect either the validity of this agreement or any part hereof or the right of the disclosing party to enforce the provisions of this agreement.

11. **DOMICILIUM**

11.1 The parties choose as their *domicilium* the addresses indicated in the heading to this agreement for the purposes of giving any notice, the payment of any sum, the serving of any process and for any other purpose arising from this agreement.

11.2 Each of the parties shall be entitled from time to time, by written notice to the other, to vary its domicilium to any other address which is not a post office box or poste restante.

11.3 Any notice required or permitted to be given in terms of this agreement shall be valid and effective only if in writing.

11.4 Any notice given and any payment made by one party to the other ("the addressee") which:

11.4.1 is delivered by hand during the normal business hours of the addressee at the addressee's domicilium for the time being shall be presumed, until the contrary is proved, to have been received by the addressee at the time of delivery;

11.4.2 is posted by prepaid registered post from an address within the Republic of South Africa to the addressee at the addressee's domicilium for the time being shall be presumed, until the



contrary is proved, to have been received by the addressee on the fourth day after the date of posting;

11.4.3 is transmitted by facsimile to the addressee's receiving machine shall be presumed, until the contrary is proved, to have been received within one (1) hour of transmission where it is transmitted during normal business hours or, if transmitted outside normal business hours, within one (1) hour of the resumption of normal business hours on the next normal business day.

12. **GENERAL**

12.1 No party shall be bound by any representation, warranty, undertaking, promise or the like not recorded in this agreement.

12.2 No addition to, variation or agreed cancellation of this agreement shall be of any force or effect unless in writing and signed by or on behalf of the parties.

12.3 Any indulgence which either party may show to the other in terms of or pursuant to the provisions contained in this agreement shall not constitute a waiver of any of the rights of the party which granted such indulgence.

12.4 The parties acknowledge that this agreement and the undertakings given by it in terms hereof are fair and reasonable in regard to their nature, extent and period and go no further than is reasonably necessary to protect the interests of the parties.

12.5 The parties hereby confirm that they have entered into this agreement with full and clear understanding of the nature, significance and effect thereof and freely and voluntarily and without duress.

12.6 Neither party shall have the right to assign or otherwise transfer any of its rights or obligations under this agreement.

12.7 This agreement may be executed in several counterparts that together shall constitute one and the same instrument.

12.8 In this agreement, clause headings are for convenience and shall not be used in its interpretation.

12.9 Each clause of this agreement is severable, the one from the other and if any one or more clauses are found to be invalid or unenforceable, that clause shall not affect the balance of the clauses which shall remain in full force and effect.

SIGNED at _____ on _____ day of _____ 202_____

AIRPORTS COMPANY SOUTH AFRICA SOC LIMITED
the signatory warranting that he is duly authorised thereto.

Name: _____

Designation: _____

AS WITNESSES

1. _____



2. _____

SIGNED at _____ on _____ day of _____ 202__

[NAME OF SERVICE PROVIDER]

the signatory warranting that s/he is duly authorised thereto.

Name: _____

Designation: _____

AS WITNESSES

1. _____

2. _____

Form B1 to Form B5: Certificates

Attach the following Certificates to this page:

- B1:** Proof of registration for Contractor's WCA registration or COID
- B2:** An original Certificate of Contractor Registration issued by the Construction Industry Development Board (CIDB)
- B3:** SARS Pin issued by the South African Revenue Services
- B4:** An original Bank Statement of good financial standing. (This document shall include a Bank Rating for the tender sum as indicated below)
- B5:** Central Supplier Database (CSD) proof of registration with Supplier number (MAAA) and Unique registration number

Bank Report on : *(Tenderers Name)*
 Account No :
 Bank :
 Branch Code :
 Amount : *(Tender Value)*
 Duration : **XX months** (excluding special non-working days)

BUSINESS POTENTIAL CODE (MARK X AGAINST APPLICABLE CLASSIFICATION)

- | | | |
|--------------------------|---|---|
| <input type="checkbox"/> | A | UNDOUBTED FOR INQUIRY |
| <input type="checkbox"/> | B | GOOD FOR AMOUNT QUOTED |
| <input type="checkbox"/> | C | GOOD FOR AMOUNT QUOTED IF STRICTLY IN WAY OF BUSINESS |
| <input type="checkbox"/> | D | FAIR TRADE RISK |
| <input type="checkbox"/> | E | FIGURE CONSIDER TOO HIGH |
| <input type="checkbox"/> | F | FINANCIAL POSITION UNKNOWN |
| <input type="checkbox"/> | G | OCCASIONALLY DISHONOURED |
| <input type="checkbox"/> | H | FREQUENTLY DISHONOURED |

Form C1: Compulsory Enterprise Questionnaire

The following particulars must be furnished. In the case of a joint venture, separate enterprise questionnaires in respect of each partner must be completed and submitted.

Section 1: Name of enterprise:

Section 2: VAT registration number, if any:

Section 3: cidb registration number, if any:

Section 4: CSD number:

Section 5: Particulars of sole proprietors and partners in partnerships:

** Complete only if sole proprietor or partnership and attach separate page if more than 3 partners*

Section 6: Particulars of companies and close corporations

Company registration number:

Close corporation number:

Tax reference number:

Section 7: SBD4 issued by National Treasury must be completed for each tender and be attached as a tender requirement.

Section 8: SBD 6 issued by National Treasury must be completed for each tender and be attached as a tender requirement.

The undersigned, who warrants that he / she is duly authorised to do so on behalf of the enterprise:

- i) authorizes the employer to verify the tenderers tax clearance status from the South African Revenue Services that it is in order;
- ii) confirms that the neither the name of the enterprise or the name of any partner, manager, director or other person, who wholly or partly exercises or may exercise, control over the enterprise appears on the Register of Tender Defaulters established in terms of the Prevention and Combating of Corrupt Activities Act of 2004;
- iii) confirms that no partner, member, director or other person, who wholly or partly exercises, or may exercise, control over the enterprise appears, has within the last five years been convicted of fraud or corruption;
- iv) confirms that I / we are not associated, linked or involved with any other tendering entities submitting tender offers and have no other relationship with any of the tenderers or those responsible for compiling the scope of work that could cause or be interpreted as a conflict of interest; and
- iv) confirms that the contents of this questionnaire are within my personal knowledge and are to the best of my belief both true and correct.

Signed		Date	
Name		Position	
<i>Enterprise name</i>			

Form C2: Proposed Domestic Subcontractors

We notify you that it is our intention to employ the following Subcontractors for work in this contract.

If we are awarded a contract, we agree that this notification does not change the requirement for us to submit the names of proposed Subcontractors in accordance with requirements in the contract for such appointments. If there are no such requirements in the contract, then your written acceptance of this list shall be binding between us.

	Name and address of proposed Subcontractor	Nature and extent of work	Previous experience with Subcontractor.
1.			
2.			
3.			
4.			
5.			

Signed		Date	
Name		Position	
Tenderer			

Form C4 Subcontractor Supporting Documents

List supporting documents required for subcontractor:

- Subcontracting Agreement between Main Contractor and Subcontract specifying percentage that will be set aside for the subcontract and the scope of work that will be executed by the subcontract.
- Proof of registration with Central Supplier Database form
- CIPC certificate
- Share Certificate
- Valid BBBEE Certificate.
- CIDB Certificate.

Signed		Date	
Name		Position	
Tenderer			

Form C5: Plant and Equipment

The following are lists of major items of relevant equipment that I/we presently own or lease and will have available for this contract or will acquire or hire for this contract if my/our tender is accepted.

(a) Details of major equipment that is owned by and immediately available for this contract.

Quantity	Description, size, capacity, etc.

Attach additional pages if more space is required.

(b) Details of major equipment that will be hired, or acquired for this contract if my/our tender is acceptable.

Quantity	Description, size, capacity, etc.

Attach additional pages if more space is required.

Signed		Date	
Name		Position	
Tenderer			

FORM C6: A certified copy of B-BBEE Verification Certificate

1. Valuation of preference points is based on tenderer's B-BBEE verification certificate for Construction Sector:
 - a) The certificate shall have been issued by:
 - i. A verification agency accredited by South African National Accreditation

- System (SANAS);
 - ii. A registered auditor approved by the Independent Regulatory Board of Auditors (IRBA);
 - b) The verification certificate must be valid at the tender closing date
 - c) Failure to submit a valid verification certificate will result in the award of zero (0) points for preference.
- 2. In the event of a Joint Venture (JV), a consolidated B-BBEE verification certificate in the name of the JV shall be submitted.
 - a) The verification certificate shall identify:
 - i. The name and *domicilium citandi et executandi* of the tenderer
 - ii. The registration and VAT number of the tenderer
 - iii. The dates of granting of the B-BBEE score and the period of validity
 - iv. The expiry date of the verification certificate
 - v. A unique identification number
- 3. The standard and/or normative document, including the issue and/or revision used to evaluate the tenderer:
 - a) The name and/or mark/logo of the B-BBEE verification agency.
 - b) The scorecard (GENERIC, QSE, EME) against which the tenderer has been verified.
 - c) The B-BBEE status level
 - d) The SANAS or IRBA logo on the verification certificate.
 - e) The B-BBEE procurement recognition level.
 - f) The score achieved per B-BBEE element.
 - g) The % black shareholding.
 - h) The % black woman shareholding.
 - i) The % black persons with disabilities.
- 4. ACSA will not be responsible to acquire data that it needs for its own reporting systems and which may not form part of a verification agency's standard certificate format. The tenderer, at its own cost, must acquire the specified data listed in 3 above from its selected verification agency and have it recorded on the certificate.

Alternatively, such missing data must be supplied separately, but certified as correct by the same verification agency and also submitted. Failure to abide by this requirement will result in such a tenderer scoring zero (0) preference.

Signed		Date	
Name		Position	
Tenderer			

FORM C7. The CV's of key personnel

Bidders are referred to [clause C.3.11](#) which indicates the maximum possible score for information requested under this schedule.

Commitment to the Project

The undersigned commits himself / herself to the overall project. He/she does not intend to cancel his/her contract or to leave the company which employs him/her within the overall duration of this project. Should the person stated above not be available for the Contract (for a *bona fide* reason), a person of at least the same experience and qualifications will need to be submitted for approval prior to taking up the position.

Note: When completing the above schedule, Tenderer's must be cognisant of the evaluation criteria as described in the Tender Data, Clause C3.11

Signed		Date	
Name		Position	
Tenderer			

FORM C8: Certified Certificates of Qualifications of Key Personnel.

Please attach certified copies of Qualifications of Key Personnel as listed under Form C7 above to this page.

Signed		Date	
Name		Position	
Tenderer			

Form C9 Work Plan and Proposed Methodology

Signed		Date	
Name		Position	
Tenderer			

Form C10. Occupational Health and Safety Questionnaire

1.	SHE POLICY, ORGANISATION AND MANAGEMENT INVOLVEMENT	YES	NO
1.1	Do you have a SHE Policy?		
	Is this signed by the senior executive?		
	Please supply copy of this policy		
1.2	Does a She structure exist in your company?		
	Please provide details		
1.3	Are senior and middle management actively involved in the promotions of SHE?		
	Please provide details e.g.		
	<ul style="list-style-type: none"> • Periodical work area inspection • Regular Health and Safety meetings with personnel 		
1.4	Are the SHE responsibilities of managers clearly defined?		
	Please provide details		
1.5	Are annual SHE objectives included in your business plan?		
	Please provide example		
1.6	Is your company registered with the Compensation Commissioner? (COID Act)?		
	If so, please provide registration number		

1.7	Do you have a copy of good standing certificate, confirming that your registration is paid up?		
	If so, please provide copy thereof		
2.	SHE TRAINING	YES	NO
2.1	Is training provided to employees at the following stages?		
	• When joining the company		
	• When changing jobs within the company		
	• When new plant or equipment needs to be operated		
	As a result of experience of and feedback from an accident/ incident reports		
	Are you able to provide proof of specialist training provided?		
	Please state how this can be achieved		
2.2	What formal SHE training is provided specifically to		
	• First line supervisors		
	Middle and top management		
	Please describe		
2.3	Are all employees (including sub-contractors) instructed as to the application of rules and regulations?		
	When is this done and how is it achieved?		
2.4	Does this training include the selection, use and care of personal protective equipment?		
2.5	What refresher training is provided and at what intervals?		
	Please list examples		
	Course Title	Target audience	Interval
2.6	Has the person(s) allocated as your SHE advisor followed specific SHE training?		
	Please list most recent courses		
	Does this include refresher training?		
3.	PURCHASE OF GOODS, MATERIALS AND SERVICES	YES	NO
3.1	Do you have a system for establishing SHE specifications as part of the assessment of goods, materials and services?		
	Please describe		
3.2	Do you have a system which ensures that all statutory inspection of plant and equipment are carried out?		
	Please give examples of plant /equipment covered		
3.3	Is there record of inspection?		
	Where is it kept?		
	Are you able to supply copies of these inspection records if required?		
3.4	How is plant and equipment, which has been inspected identifies as being safe to use?		

3.5	Do you evaluate the SHE competence of all sub-contractors?		
	Please describe how this is achieved and how the results are monitored		
4.	SHE INSPECTIONS	YES	NO
4.1	Are periodic work inspections carried out by first line supervisors or your General Safety Regulation 11(1) appointee?		
4.2	Are records of these inspections kept and available?		
4.3	During the inspections are supervisors required to check that safety rules and regulations (including personal protective equipment) are adhered to?		
4.4	Are unsafe acts and conditions reported and remedial actions formally monitored?		
	Please provide examples of the above		
5.	RULES AND REGULATIONS	YES	NO
5.1	Do health and safety rules and regulations exist for personnel and sub-contractors?		
	Do these cover		
	<ul style="list-style-type: none"> • General rules • Project rules • Specific task rules 		
5.2	Do these rules include permit to work system (as applicable)		
5.3	Do you have experience of project SHE plans?		
	Please give examples of where these have been used		
5.4	Do you have a formal company guideline for holding pre-contract health and safety meetings with the client?		
6	RISK MANAGEMENT	YES	NO
6.1	Have the following, involved in the execution of your work, been identified?		
	<ul style="list-style-type: none"> • Hazards affecting health and safety? • The groups of people who might be affected? • An evaluation of the risk from each significant hazard? • Whether the risks arising are adequately controlled? 		
6.2	Are these findings and assessments recorded?		
6.3	How often are they reviewed?		
	Please list the time frame e.g. years		
6.4	For what processes/risk is personal protective equipment issued?		
	Process/Risk	Type of PPE	
	Do you have a copy of the issue lists for PPE available on request?		
7	EMERGENCY ARRANGEMENTS	YES	NO

7.1	How do you manage your arrangements for dealing with emergencies?				
	Are these communicated to your sub-contractors?				
7.2	What provision have you made for first aid? E.g. Trained First Aiders				
7.3	What training do you provide to employees in Safety/Fire Fighting?				
	Please list institutions used for these training				
8	RECRUITMENT OF PERSONNEL	YES	NO		
8.1	Are health and Safety factors considered when hiring personnel?				
8.2	Are medical examinations carried prior to employment?				
	In all cases				
	Where type of work requires medical examination				
8.3	Do you cover exit medical examination?				
8.4	How do you assess the competence of staff before an appointment is made?				
	E.g. Via trade testing, reference checks				
9.	REPORTING AND INVESTIGATION OF ACCIDENTS, INCIDENTS AND DANGEROUS CONDITIONS	YES	NO		
9.1	Do you have a procedure for reporting, investigating and recording accidents and incidents?				
	Please supply a copy				
9.2	Is there a standard report/investigation form used?				
	Please supply a copy				
9.3	Do you have a formal system for reporting situations/near misses etc.?				
	Please provide a copy				
9.4	Please provide the following statistic for the last five years				
		YEAR1	YEAR 2	YEAR 3	YEAR 4
		YEAR 5			
	Lost time accidents per 100 employees				
	Major/ Reportable injuries per 100 employees				
	Number of dangerous occurrences				
	Lost man day due to accidents				
10	HEALTH AND SAFETY COMMUNICATION AND CONSULTATION	YES	NO		
10.1	Are Health and Safety Committee meetings held between management and appointed Health and Safety representatives?				
10.2	Are the results of these meetings communicated to all employees?				
	If Yes please describe method				
10.3	Are Health and Safety meetings held?				

	At what frequency?		
	Chaired by whom?		
10.4	Do you carry out SHE promotions / campaigns?		
	If Yes please provide examples		

The following documentation should also be provided with the tender:

1. **Management Structure including organogram**
2. **Human Resource Plan**
3. **Letter of Good Standing from the Compensation Commissioner or licensed compensation insurer**
4. **COID Insurance**

Declaration

I/wedeclare that the above information provided is correct.

Signed		Date	
Name		Position	
Tenderer			

Form C11: Schedule of Information to be provided by Tenderer

1. Company details:

Registered Address:
 Contact Person:
 Telephone:
 Fax:

2. Shareholders

Names/Percentages of holdings:

3. Bankers

Name of Account Holder :
 Bank:
 Branch:
 Account Number:
 Bank and branch contact details:

4. Turnover

Approximate turnover for each of the past three years:
 2020:
 2021:
 2022:

5. Management and Manpower Resources

Supervisors:
 Labourers:
 Other:

Name of Supervisor to be allocated to this contract:

6. Construction Equipment (Value in R)

Equipment owned by Company:
 Own workshop/stores (location):

Signed		Date	
Name		Position	
Tenderer			

Form C12: Proposed Amendments and Qualifications

The Tenderer should record any deviations or qualifications he may wish to make to the tender documents in this Returnable Schedule. Alternatively, a tenderer may state such deviations and qualifications in a covering letter to his tender and reference such letter in this schedule.

The Tenderer's attention is drawn to clause C.3.8 of the Standard Conditions of Tender referenced in the Tender Data regarding the employer's handling of material deviations and qualifications.

Page	Clause item or	Proposal

Signed		Date	
Name		Position	
Tenderer			



AIRPORTS COMPANY SOUTH AFRICA SOC LIMITED

PROJECT NAME AND NUMBER:

TITLE OF PROJECT: CONTRACTOR APPOINTMENT FOR THE ONCE OFF REPLACEMENT OF SUBMERSIBLE PUMPS AT KING SHAKA INTERNATIONAL AIRPORT.

NEC 3: ENGINEERING AND CONSTRUCTION CONTRACT (ECC)

Between AIRPORTS COMPANY SOUTH AFRICA SOC LIMITED

Applicable at [DRAFTING NOTE: KING SHAKA INTERNATIONAL AIRPORT]

(Registration Number : 1993/004149/30)

and **[DRAFTING NOTE: INSERT CONTRATOR NAME]**

(Registration Number : _____)

for **[DRAFTING NOTE: INSERT TITLE OF WORKS]**

Contents:	No of pages
Part C1 Agreements & Contract Data	[●]
Part C2 Pricing Data	[●]
Part C3 Scope of Works	[●]
Part C4 Site Information	[●]

Part C1: Agreements and Contract Data

C1.1: Form of Offer and Acceptance

Offer

The Employer, identified in the Acceptance signature block, has solicited offers to enter into a contract for the procurement of: REPLACEMENT OF SUBMIRSIBLE PUMPS

The tenderer, identified in the Offer signature block, has examined the documents listed in the Tender Data and addenda thereto as listed in the Returnable Schedules, and by submitting this Offer has accepted the Conditions of Tender.

By the representative of the tenderer, deemed to be duly authorised, signing this part of this Form of Offer and Acceptance the tenderer offers to perform all of the obligations and liabilities of the **Contractor** under the contract including compliance with all its terms and conditions according to their true intent and meaning for an amount to be determined in accordance with the conditions of contract identified in the Contract Data.

THE OFFERED TOTAL OF THE PRICES INCLUSIVE OF VAT IS:

(in words)
..... Rands;

(in figures) R.....

THE OFFERED PRICES ARE AS STATED IN THE PRICING SCHEDULE

This Offer may be accepted by the Employer by signing the Acceptance part of this Form of Offer and Acceptance and returning one copy of this document including the Schedule of Deviations (if any) to the tenderer before the end of the period of validity stated in the Tender Data, or other period as agreed, whereupon the tenderer becomes the party named as the **Contractor** in the conditions of contract identified in the Contract Data.

Signature(s)

Name(s)

Capacity

For the Bidder:

Name & signature of witness

.....
(Insert name and address of organisation)

.....
Date

Acceptance

By signing this part of this Form of Offer and Acceptance, the Employer identified below accepts the tenderer's Offer. In consideration thereof, the Employer shall pay the **Contractor** the amount due in accordance with the conditions of contract identified in the Contract Data. Acceptance of the tenderer's Offer shall form an agreement between the Employer and the tenderer upon the terms and conditions contained in this agreement and in the contract that is the subject of this agreement.

The terms of the contract, are contained in:

- Part C1 Agreements and Contract Data, (which includes this Form of Offer and Acceptance)
- Part C2 Pricing Data
- Part C3 Scope of Work: Works Information
- Part C4 Site Information

and drawings and documents (or parts thereof), which may be incorporated by reference into the above listed Parts.

Deviations from and amendments to the documents listed in the Tender Data and any addenda thereto listed in the Returnable Schedules as well as any changes to the terms of the Offer agreed by the tenderer and the Employer during this process of offer and acceptance, are contained in the Schedule of Deviations attached to and forming part of this Form of Offer and Acceptance. No amendments to or deviations from said documents are valid unless contained in this Schedule.

The tenderer shall within two weeks of receiving a completed copy of this agreement, including the Schedule of Deviations (if any), contact the Employer's agent (whose details are given in the Contract Data) to arrange the delivery of any securities, bonds, guarantees, proof of insurance and any other documentation to be provided in terms of the conditions of contract identified in the Contract Data. Failure to fulfil any of these obligations in accordance with those terms shall constitute a repudiation of this agreement.

Notwithstanding anything contained herein, this agreement comes into effect on the date when the tenderer receives one fully completed original copy of this document, including the Schedule of Deviations (if any). Unless the tenderer (now **Contractor**) within five working days of the date of such receipt notifies the Employer in writing of any reason why he cannot accept the contents of this agreement, this agreement shall constitute a binding contract between the Parties.

Signature(s)

Name(s)

Capacity

**for the
Employer**

.....

.....

.....

.....

Name & signature of witness	<i>(Insert name and address of organisation)</i>	Date
-----------------------------------	--	------

Schedule of Deviations

1 Subject

 Details

.....

.....

.....

.....

.....

2 Subject

 Details

.....

.....

.....

.....

.....

3 Subject

 Details

.....

.....

.....

.....

By the duly authorised representatives signing this agreement, the Employer and the Tenderer agree to and accept the foregoing schedule of deviations as the only deviations from and amendments to the documents listed in the Tender Data and addenda thereto as listed in the returnable schedules, as well as any confirmation, clarification or changes to the terms of the offer agreed by the Tenderer and the Employer during this process of offer and acceptance.

It is expressly agreed that no other matter whether in writing, oral communication or implied during the period between the issue of the tender documents and the receipt by the tenderer of a completed signed copy of this Agreement shall have any meaning or effect in the contract between the parties arising from this agreement.

	<u>For the Employer</u>	<u>For the Bidder</u>
Signature (s)
Name (s)
Capacity
Name and Address	Airports Company South Africa SOC Limited	
Name & Signature of witness	<i>(Insert name and address of organisation)</i>	<i>(Insert name and address of organisation)</i>
Date

Part C1.2a Contract Data

Part one – Data provided by the *Employer*

The Conditions of contract are selected from the NEC3 Engineering and Construction Contract, April 2013.

Each item of data given below is cross-referenced to the NEC3 Engineering Construction Contract which requires it.

Clause	Statement	Data
1	General	
	The <i>conditions of contract</i> are the core clauses and the clauses for Main Option	
	Main Option	B: Priced contract with Bill of Quantities
	Dispute resolution Option	W1: Dispute resolution procedure
	Secondary Options (incorporating amendments)	X2: Changes in the law X7: Delay damages X13: Performance Bond X16: Retention X18: Limitation of liability Z: Additional conditions of contract
		of the NEC3 Engineering and Construction Contract, April 2013
10.1	The <i>Employer</i> is (Name)	Airports Company South Africa SOC Limited, Applicable to King Shaka International Airport
	Address	Airports Company South Africa SOC Limited King Shaka International Airport La Mercy Drive La Mercy
	Telephone	032 436 6000
10.1	The <i>Project Manager</i> is	
	Address	King Shaka International Airport
	Telephone	
	E-mail address	

10.1	The <i>Supervisor</i> is	
	Address	
	Telephone	
	Fax	
	Email	
11.2	The <i>works</i> are	Replacement of Submersible Pumps
11.2	The following matters will be included in the Risk Register	<ul style="list-style-type: none"> • Availability of As Built information • Access to Site • Site Constraints and Constructability
11.2	The <i>Works Information</i> is in	Part C3 'Scope of Works' section of this contract
11.2	The <i>Site Information</i> is in	Part C4 'Works Information' section of this contract
11.2	The <i>boundary of the site</i> is	
12.2	The <i>law of the contract</i> is the law of	the Republic of South Africa
13.1	The <i>language of this contract</i> is	English
13.3	The <i>period of reply</i> is	Seven (7) days
3	Time	
31.2	The <i>starting date</i> is	
11.2	The <i>completion date</i> is	
30.1	The <i>access date</i> is	
31.1	The <i>Contractor</i> submits a first (preliminary) programme with the tender by the tender closing date	
32.2	The <i>Contractor</i> submits revised programmes at intervals no longer than	Four (4) weeks

35.1	The <i>Employer</i> is not willing to take over the works before the <i>completion date</i>	The <i>Employer</i> and Others will have access to the <i>works</i> during construction or prior to completion. Such access by the <i>Employer</i> and Others shall not relieve the <i>Contractor</i> from liability for the completion of the <i>works</i> in accordance with the Works Information and in terms of this contract.																												
4	Testing and Defects																													
42.2	The <i>defects date</i> is	Twelve (12) months after Completion of the whole of the <i>works</i>																												
43.2	The <i>defects correction period</i> is	Two (2) weeks																												
5	Payment																													
50.1	The <i>assessment interval</i> is	Two (2) weeks																												
50.1	The <i>currency of this contract</i> is the	South African Rand																												
51.2	The period within which payment is made is	Four (4) weeks																												
51.4	The <i>interest rate</i> is	The prime lending rate of the Nedbank Bank. as determined from time to time																												
6	Compensation events																													
60.1	The <i>weather measurements</i> to be recorded for each calendar month are	the cumulative rainfall (mm) the number of days with rainfall more than 10 mm the number of days with minimum air temperature less than 0 degrees Celsius																												
60.1	The place where weather is to be recorded (on the Site) is	At the Construction Site Office and the records to be kept on site in a file clearly marked for this purpose																												
60.1	Assumed values for the ten year return <i>weather data</i> for each <i>weather measurement</i> for each calendar month are	<table border="1"> <thead> <tr> <th>Month</th> <th>Days</th> <th>Month</th> <th>Days</th> </tr> </thead> <tbody> <tr> <td>January</td> <td>1</td> <td>July</td> <td>4</td> </tr> <tr> <td>February</td> <td>1</td> <td>August</td> <td>3</td> </tr> <tr> <td>March</td> <td>2</td> <td>September</td> <td>2</td> </tr> <tr> <td>April</td> <td>2</td> <td>October</td> <td>2</td> </tr> <tr> <td>May</td> <td>3</td> <td>November</td> <td>2</td> </tr> <tr> <td>June</td> <td>3</td> <td>December</td> <td>1</td> </tr> </tbody> </table>	Month	Days	Month	Days	January	1	July	4	February	1	August	3	March	2	September	2	April	2	October	2	May	3	November	2	June	3	December	1
Month	Days	Month	Days																											
January	1	July	4																											
February	1	August	3																											
March	2	September	2																											
April	2	October	2																											
May	3	November	2																											
June	3	December	1																											
7	Title	No data required for this section of the <i>conditions of contract</i>																												
8	Risks and Insurance																													
84.1	The <i>Employer</i> provides these insurances	Refer to the Insurance Clauses which is attached at the end of the Contract Data																												
84.2	The <i>Contractor</i> provides the insurance stated in	The Insurance Clauses which is attached at the end of the Contract Data. The insurances are in the joint names of the Parties and provide cover for events which are at the Contractor's risk from the starting date until the Defects Certificate or a termination certificate has been issued.																												

The minimum limit of indemnity for insurance in respect of death of or bodily injury to employees of the Contractor arising out of and in the course of their employment in connection with this contract for any one event is:

As prescribed by the Compensation for Occupational Injuries and Diseases Act No. 130 of 1993

9	Termination	No data required for this section of the <i>conditions of contract</i>
10	Data for Main Options	
B	Priced contract with Bill of Quantities	
11	Data for Option W1	
W1.1	The <i>Adjudicator</i> is	The person appointed jointly by the parties from the list of adjudicators contained below
W1.2	The <i>Adjudicator nominating body</i> is	The current Chairman of Johannesburg Advocate's Bar Council
W1.4	The <i>tribunal</i> is	Arbitration
W1.4	If the <i>tribunal</i> is arbitration, the arbitration procedure is	The <i>arbitration procedure</i> is set out in The Rules for the Conduct of Arbitrations 2013 Edition, 7th Edition, published by The Association of Arbitrators, (Southern Africa)
W1.4	The place where arbitration is to be held is	Johannesburg, South Africa.
W1.4	The person or organisation who will choose an arbitrator	The <i>Arbitrator</i> is the person selected by the Parties as and when a dispute arises in terms of the relevant Z Clause, from the Panel of Arbitrators provided under the relevant Z clause if the arbitration procedure does not state who selects an arbitrator. The Arbitrator nominating body is the Chairman of the Johannesburg Advocates Bar Council.
12	Data for Secondary Option Clauses	
X7	Delay Damages	
	Delay damages of the <i>works</i> are	Amount per day is 0.05%, to the maximum of 10% of the Contract value
X13	Performance bond	
X13.1	The amount of the performance bond is	10% of the contract value. Pro-forma draft of a performance bond to be used is attached to this contract.
X16	Retention	

X16.1 The *retention percentage* is 5% of the Contract value.

X18 Limitation of Liability

X18.1 The *Contractor's* liability to the *Employer* for indirect or consequential loss is limited to Nil - Neither Party is liable to the other for any consequential or indirect loss, including but not limited to loss of profit, loss of income or loss of revenue

X18.2 For any one event, the *Contractor's* liability to the *Employer* for loss of or damage to the *Employer's* property is limited to The total of the Prices

X18.3 The *Contractor's* total liability to the *Employer* for defects due to his design which are not listed on the Defects Certificate is limited to The total of the Prices

X18.4 The *Contractor's* total liability to the *Employer* for all matters arising under or in connection with this contract, other than excluded matters, is limited to The Contractor's total direct liability to the Employer for all matters arising under or in connection with this contract, other than the excluded matters, is limited to the total of the Prices and applies in contract, tort or delict and otherwise to the extent allowed under the law of the contract.

The e excluded matters are amounts payable by the Contractor as stated in this contract for

- Loss of or damage to the Employer's property,
- Delay damages,
- Defects liability,
- Insurance liability to the extent of the Contractor's risks
- loss of or damage to property (other than the *works*, Plant and Materials),
- death of or injury to a person;
- damage to third party property; and
- infringement of an intellectual property right

Z The Additional conditions of Z1 – Z20 contract are

Amendments to the Core Clauses

Z1 Interpretation of the law

Z1.1 Add to core clause 12.3:

Any extension, concession, waiver or relaxation of any action stated in this contract by the Parties, the *Project Manager*, the *Supervisor*, or the *Adjudicator* does not constitute a waiver of rights, and does not give rise to an estoppel unless the Parties agree otherwise and confirm such agreement in writing.

Z2	Providing the Works:
Z2.1	Delete core clause 20.1 and replace with the following: The <i>Contractor</i> provides the works in accordance with the Works Information and warrants that the results of the Works, when complete, shall be fit for their intended purpose
Z3	Other responsibilities:
	Add the following at the end of core clause 27:
Z3.1	The <i>Contractor</i> shall have satisfied himself, prior to the Contract Date, as to the completeness, sufficiency and accuracy of all information and drawings provided to him as at the Contract Date
Z3.2	The <i>Contractor</i> shall be responsible for the correct setting out of the <i>Works</i> in accordance with the original points, lines and levels stated in the <i>Works</i> Information or notified by the <i>Project Manager</i> , <i>Supervisor</i> or the <i>Employer</i> . Any errors in the positioning of the <i>Works</i> shall be rectified by the <i>Contractor</i> at the <i>Contractor's</i> own costs.
Z4	Extending the defects date:
	Add the following as a new core clause 46:
Z4.1	If the <i>Employer</i> cannot use the <i>works</i> due to a Defect, which arises after Completion and before the <i>defects date</i> , the <i>defects date</i> is delayed by a period equal to that during which the <i>Employer</i> , due to a Defect, is unable to use the <i>works</i>
Z4.2	If part of the <i>works</i> is replaced due to a Defect arising after Completion and before the <i>defects date</i> , the <i>defects date</i> for the part of the <i>works</i> which is replaced is delayed by a period equal to that between Completion and the date by when the part has been replaced
Z4.3	The <i>Project Manager</i> notifies the <i>Contractor</i> of the change to a <i>defect date</i> when the delay occurs. The period between Completion and an extended <i>defects date</i> does not exceed twice the period between Completion and the <i>defects date</i> stated in the Contract Data
Z5	Termination
Z5.1	Add the following to core clause 91.1, at the second main bullet, fifth sub-bullet point, after the words "assets or": "business rescue proceedings are initiated or steps are taken to initiate business rescue proceedings".
Amendment to the Secondary Option Clauses	
Z6	Performance Bond
Z6.1	Amend the first sentence of clause X13.1 to read as follows: The <i>Contractor</i> gives the <i>Employer</i> an unconditional, on-demand performance bond, provided by a bank which the <i>Project Manager</i> and the <i>Employer</i> have accepted, for the amount stated in the Contract Data and in the form set out in Annexure C.ii of this Contract Data.
Z6.2	Add the following new clause as Option X13.2: The <i>Contractor</i> ensures that the performance bond is valid and enforceable until the end of the <i>contract period</i> . If the terms of the performance bond specify its expiry date and the end of the <i>contract period</i> does not coincide with such expiry date, four weeks prior to the said expiry date, the <i>Contractor</i> extends the validity of the performance bond until the end of the <i>contract period</i> . If the <i>Contractor</i> fails to so extend the validity of the performance bond, the <i>Employer</i> may claim the full amount of the performance bond and retain the proceeds as cash security
Z7	Limitation of liability:

Insert the following new clause as Option X18.6:

- Z7.1** The *Employer's* liability to the *Contractor* for the *Contractor's* indirect or consequential loss is limited to R0.00
- Z7.2** Notwithstanding any other clause in this contract, any proceeds received from any insurances or any proceeds which would have been received from any insurances but for the conduct of the *Contractor* shall be excluded from the calculation of the limitations of liability listed in the contract

Additional Z Clauses**Z8 Cession, delegation and assignment**

- Z8.1** The *Contractor* shall not cede, delegate or assign any of its rights or obligations to any person without the written consent of the *Employer*, which consent shall not be unreasonably withheld. This clause shall be binding on the liquidator/business rescue practitioner /trustee (whether provisional or not) of the *Contractor*
- Z8.2** The *Employer* may cede and delegate its rights and obligations under this contract to any person or entity

Z9 Joint and several liability

- Z9.1** If the *Contractor* constitutes a joint venture, consortium or other unincorporated grouping of two or more persons, these persons are deemed to be jointly and severally liable to the *Employer* for the performance of the Contract.
- Z9.2** The *Contractor* shall, within 1 week of the Contract Date, notify the *Project Manager* and the *Employer* of the key person who has the authority to bind the *Contractor* on their behalf.
- Z9.3** The *Contractor* does not materially alter the composition of the joint venture, consortium or other unincorporated grouping of two or more persons without prior written consent of the *Employer*.

Z10 Ethics

- Z10.1** The *Contractor* undertakes:
- Z10.1.1** not to give any offer, payment, consideration, or benefit of any kind, which constitutes or could be construed as an illegal or corrupt practice, either directly or indirectly, as an inducement or reward for the award or in execution of this contract;
- Z10.1.2** to comply with all laws, regulations or policies relating to the prevention and combating of bribery, corruption and money laundering to which it or the *Employer* is subject, including but not limited to the Prevention and Combating of Corrupt Activities Act, 12 of 2004.
- Z10.2** The *Contractor's* breach of this clause constitutes grounds for terminating the *Contractor's* obligation to Provide the Works or taking any other action as appropriate against the *Contractor* (including civil or criminal action). However, lawful inducements and rewards shall not constitute grounds for termination.
- Z10.3** If the *Contractor* is found guilty by a competent court, administrative or regulatory body of participating in illegal or corrupt practices, including but not limited to the making of offers (directly or indirectly), payments, gifts, gratuity, commission or benefits of any kind, which are in any way whatsoever in connection with the contract with the *Employer*, the *Employer* shall be entitled to terminate the contract in accordance with the procedures stated in core clause 92.2. the amount due on termination is A1.

Z11	Confidentiality
Z11.1	All information obtained in terms of this contract or arising from the implementation of this contract shall be treated as confidential by the <i>Contractor</i> and shall not be used or divulged or published to any person not being a party to this contract, without the prior written consent of the <i>Project Manager</i> or the <i>Employer</i> , which consent shall not be unreasonably withheld.
Z11.2	If the <i>Contractor</i> is uncertain about whether any such information is confidential, it is to be regarded as such until otherwise notified by the <i>Project Manager</i> .
Z11.3	This undertaking shall not apply to –
Z11.3.1	Information disclosed to the employees of the <i>Contractor</i> for the purposes of the implementation of this agreement. The <i>Contractor</i> undertakes to procure that its employees are aware of the confidential nature of the information so disclosed and that they comply with the provisions of this clause;
Z11.3.2	Information which the <i>Contractor</i> is required by law to disclose, provided that the <i>Contractor</i> notifies the <i>Employer</i> prior to disclosure so as to enable the <i>Employer</i> to take the appropriate action to protect such information. The <i>Contractor</i> may disclose such information only to the extent required by law and shall use reasonable efforts to obtain assurances that confidential treatment will be afforded to the information so disclosed;
Z11.3.3	Information which at the time of disclosure or thereafter, without default on the part of the <i>Contractor</i> , enters the public domain or to information which was already in the possession of the <i>Contractor</i> at the time of disclosure (evidenced by written records in existence at that time);
Z11.4	The taking of images (whether photographs, video footage or otherwise) of the <i>works</i> or any portion thereof, in the course of Providing the Works and after Completion, requires the prior written consent of the <i>Project Manager</i> . All rights in and to all such images vests exclusively in the <i>Employer</i>
Z11.5	The <i>Contractor</i> ensures that all his Subcontractors abide by the undertakings in this clause.
Z12	Employer's Step-in rights
Z12.1	If the <i>Contractor</i> defaults by failing to comply with his obligations and fails to remedy such default within 2 weeks of the notification of the default by the <i>Project Manager</i> , the <i>Employer</i> , without prejudice to his other rights, powers and remedies under the contract, may remedy the default either himself or procure a third party (including any subcontractor or supplier of the <i>Contractor</i>) to do so on his behalf. The reasonable costs of such remedial works shall be borne by the <i>Contractor</i>
Z12.2	The <i>Contractor</i> co-operates with the <i>Employer</i> and facilitates and permits the use of all required information, materials and other matter (including but not limited to documents and all other drawings, CAD materials, data, software, models, plans, designs, programs, diagrams, evaluations, materials, specifications, schedules, reports, calculations, manuals or other documents or recorded information (electronic or otherwise) which have been or are at any time prepared by or on behalf of the <i>Contractor</i> under the contract or otherwise for and/or in connection with the <i>works</i>) and generally does all things required by the <i>Project Manager</i> to achieve this end.
Z13	Liens and Encumbrances
Z13.1	The <i>Contractor</i> keeps the Equipment used to Provide the Services free of all liens and other encumbrances at all times. The <i>Contractor</i> , vis-a-vis the <i>Employer</i> , waives all and any liens which he may from time to time have, or become entitled to over such Equipment and any part thereof and procures that his Subcontractors similarly, vis-a-vis the <i>Employer</i> , waive all liens they may have or become entitled to over such Equipment from time to time

Z14	Intellectual Property
------------	------------------------------

Z14.1	Intellectual Property (“IP”) rights means all rights in and to any patent, design, copyright, trade mark, trade name, trade secret or other intellectual or industrial property right relating to the Works.
Z14.2	IP rights remain vested in the originator and shall not be used for any reason whatsoever other than carrying out the <i>works</i> .
Z14.3	The <i>Contractor</i> gives the <i>Employer</i> an irrevocable, transferrable, non-exclusive, royalty free licence to use and copy all IP related to the <i>works</i> for the purposes of constructing, repairing, demolishing, operating and maintaining the works
Z14.4	The written approval of the <i>Contractor</i> is to be obtained before the <i>Contractor’s</i> IP made available to any third party which approval will not be unreasonably withheld or delayed. Prior to making any <i>Contractor’s</i> IP available to any third party the <i>Employer</i> shall obtain a written confidentiality undertaking from any such third party on terms no less onerous than the terms the <i>Employer</i> would use to protect its IP
Z14.5	The <i>Contractor</i> shall indemnify and hold the <i>Employer</i> harmless against and from any claim alleging an infringement of IP rights (“ the claim ”), which arises out of or in relation to:
Z14.5.1	the <i>Contractor’s</i> design, manufacture, construction or execution of the Works
Z14.5.2	the use of the <i>Contractor’s</i> Equipment, or
Z14.5.3	the proper use of the Works.
Z14.6	The <i>Employer</i> shall, at the request and cost of the <i>Contractor</i> , assist in contesting the claim and the <i>Contractor</i> may (at its cost) conduct negotiations for the settlement of the claim, and any litigation or arbitration which may arise from it.

Z16	Dispute resolution:
------------	----------------------------

Z16.1	Appointment of the Adjudicator
--------------	---------------------------------------

An *Adjudicator* is appointed when a dispute arises, from the Panel of Adjudicators below. The referring party nominates an Adjudicator, which nomination is either accepted or rejected by the other party. In the instance of a rejection of the nominated *Adjudicator*, the referring Party refers the appointment deadlock to the Chairman of the Johannesburg Bar Council, who appoints an *Adjudicator* listed in the Panel of Adjudicators below

The Parties appoint the *Adjudicator* under the NEC3 Adjudicator's Contract, April 2013

Panel of Adjudicators

Name	Location	Contact details (phone & e mail)
Adv. Ghandi Badela	Gauteng	+27 11 282 3700 gandi@badela.co.za
Mr. Errol Tate Pr. Eng.	Durban	+27 11 262 4001 Errol.tate@mweb.co.za
Adv. Saleem Ebrahim	Gauteng	+27 11 535-1800 salimebrahim@mweb.co.za
Mr. Sebe Msutwana Pr. Eng.	Gauteng	+27 11 442 8555 sebe@civilprojects.co.za
Mr. Sam Amod	Gauteng	sam@samamod.com
Adv. Sias Ryneke SC	Gauteng	083 653 2281 reyneke@duma.nokwe.co.za
Mr. Emeka Ogbugo (Quantity Surveyor)	Pretoria	+27 12 349 2027 emeka@gosiame.co.za

Z16.2 Appointment of the Arbitrator

An *Arbitrator* is appointed when a dispute arises from the Panel of Arbitrators below. The referring party nominates an Arbitrator, which nomination is either accepted or rejected by the other party. In the instance of a rejection of the nominated *Arbitrator*, the referring Party refers the appointment deadlock to the Chairman of the Johannesburg Bar Council, who appoints an *Arbitrator* listed in the Panel of *Arbitrators* below

Panel of Arbitrators

Name	Location	Contact details (phone & e mail)
Adv. Ghandi Badela	Gauteng	+27 11 282 3700 gandi@badela.co.za
Mr. Errol Tate Pr. Eng.	Durban	+27 11 262 4001 Errol.tate@mweb.co.za
Adv. Saleem Ebrahim	Gauteng	+27 11 535-1800 salimebrahim@mweb.co.za
Mr. Sebe Msutwana Pr. Eng.	Gauteng	+27 11 442 8555 sebe@civilprojects.co.za
Mr. Sam Amod	Gauteng	sam@samamod.com
Adv. Sias Ryneke SC	Gauteng	083 653 2281 reyneke@duma.nokwe.co.za
Mr. Emeka Ogbugo (Quantity Surveyor)	Pretoria	+27 12 349 2027 emeka@gosiame.co.za

Z17 Notification of a compensation event

Z17.1 Delete "eight weeks" in clause 61.3 and replace with "four weeks". Delete the words "unless the event arises from the Project Manager or the Supervisor giving an instruction, issuing a certificate, changing an earlier decision or correcting an assumption."

Z18 BBEE Certificate

Z18.1 The *Contractor* shall be expected to annually present a compliant BEE Certificate. Failure to do adhere to these requirements shall be considered a material breach of the conditions of this Contract, the sanction for which may be a cancellation of this Contract.

Z19 Communication

Z19.1 **Add a new Core Clause** 14.5 and 14.6 to read as follows:

The *Project Manager* requires the written consent of the Employer if an action will result in a change to the design, scope, and Works information that is 5% or more

Z19.2 The *Project Manager* requires the written consent of the Employer if an action will result in the Completion Date being extended by more than 30 days.

Z20 Delegation

As stipulated by Section 37(2) of the Occupational Health and Safety Act No. 85 of 1993 as amended the *Contractor* agrees to the following:

Z20.1 As part of this contract the *Contractor* acknowledge that it (mandatory) is an employer in its own right with duties as prescribed in the Occupational Health and Safety Act No 85 of 1993 as amended and agree to ensure that all work being performed, or Equipment, Plant and Materials being used, are in accordance with the provisions of the said Act, and in particular with regard to the Construction Regulations

PART C1.2b CONTRACT DATA

PART TWO – DATA PROVIDED BY THE CONTRACTOR

Clause	Statement	Data
10.1	The Contractor is (Name): Address: Telephone No. Fax No.	
11.2	The <i>working areas</i> are	Only the Site Area. See C4 'Site Information'
24.1	The <i>Contractor's Key people</i> are:	CV's to be appended to Tender Schedule
	Name:	
	Job:	
	Responsibility:	
	Qualifications:	
	Experience:	
	Name:	
	Job:	
	Responsibility:	
	Qualifications:	
	Experience:	
	Name:	
	Job:	
	Responsibility:	
	Qualifications:	
	Experience:	

Name:

Job:

Responsibility:

Qualifications:

Experience:

11.2	The <i>completion date</i> is	
------	-------------------------------	--

11.2	The following matters will be included in the Risk Register	<ul style="list-style-type: none">• Existing Services• Access to Site• Delay in supply of material and/or equipment• Progress of the works against the program• Travelling public and ACSA stakeholders
------	---	---

11.2	The <i>Works Information</i> is in	Part C3 'Scope of Works' section of this contract
------	------------------------------------	---

31.1	The programme identified in the	
------	---------------------------------	--

Part C1: Agreements and Contract Data

C1.3: Form of Guarantee

PRO FORMA FOR PERFORMANCE BOND

PERFORMANCE BOND

[TO BE REPLICATED ON BANK'S LETTERHEAD]

Brief description of contract.....

Name and address of Beneficiary.....

..... (whom the contract defines as the Contractor).

We, the undersigned and..... in our capacities as Guarantor's..... of (**Registration Number:**) (hereinafter called "the Bank") have been informed that hereinafter called the 'Principal') is your Contractor under such contract, which requires him to obtain an irrevocable, unconditional performance security.

At the request of the Principal, we(name of bank) hereby irrevocably undertake to pay you, the Employer, any sum or sums not exceeding in total the amount of(the "Guaranteed Amount") upon receipt by us of your first written demand stating that such an amount (or lesser amount) as may be claimed is due and payable to the Employer.

This guarantee constitute an irrevocable, unconditional, non-negotiable and non-transferable undertaking to pay in accordance with the above, subject to the proviso that this Letter will not be interpreted as extending the Bank's liability to anything more than the Guaranteed Amount.

Notwithstanding anything to the contrary herein contained, the Bank's obligation shall be construed as principal and not as accessory to the contract and shall not be delayed or discharged by the fact that a dispute exists between the Employer and the Contractor.

We undertake to pay you such Guaranteed Amount upon receipt by us, within such period of 14 days, of your first written demand stating that such an amount (or lesser amount) as may be claimed is due and payable to the Employer.

The guarantee shall be governed by and construed in accordance with the laws of the Republic of South Africa

Signed at _____ on _____ 20....

For:

Registration Number:

Name & Position

As witnesses:

1. _____

2. _____

PART C1: AGREEMENTS AND CONTRACT DATA

C1.4: OCCUPATIONAL HEALTH AND SAFETY AGREEMENT

OCCUPATIONAL HEALTH AND SAFETY AGREEMENT

AGREEMENT IN TERMS OF SECTION 37(2) OF THE OCCUPATIONAL HEALTH & SAFETY ACT (ACT 85 Of 1993) & CONSTRUCTION REGULATION 5.1(k)

OBJECTIVES

To assist Airport Company South Africa (ACSA) in order to comply with the requirements of:

1. The Occupational Health & Safety (Act 85 of 1993) and its regulations and
2. The Compensation for Occupational Injuries & Diseases Act (Act 130 of 1993) also known as the (COID Act).

To this end an Agreement must be concluded before any contractor/ subcontracted work may commence

The parties to this Agreement are:

Name of Organisation: AIRPORTS COMPANY SOUTH AFRICA KING SHAKA INTERNATIONAL AIRPORT
Physical Address: Airport Company South Africa King Shaka Drive, La Mercy

Hereinafter referred to as “Client”

Name of organisation:
Physical Address

Hereinafter referred to as “the Mandatary/ Principal Contractor”

MANDATORY'S MAIN SCOPE OF WORK

GENERAL INFORMATION FORMING PART OF THIS AGREEMENT

1. The Occupational Health & Safety Act comprises of SECTION 1-50 and all unrepealed REGULATIONS promulgated in terms of the former Machinery and Occupational Safety Act No.6 of 1983 as amended as well as other REGULATIONS which may be promulgated in terms of the Act and other relevant Acts pertaining to the job in hand.
2. "Mandatory" is defined as including as agent, a principal contractor or a contractor for work, but WITHOUT DEROGATING FROM HIS/HER STATUS IN HIS/HER RIGHT AS AN EMPLOYER or user of the plant
3. Section 37 of the Occupational Health & Safety Act potentially punishes Employers (PRINCIPAL CONTRACTOR) for unlawful acts or omissions of Mandatories (CONTRACTORS) save where a Written Agreement between the parties has been concluded containing arrangements and procedures to ensure compliance with the said Act BY THE MANDATARY.
4. All documents attached or refer to in the above Agreement form an integral part of the Agreement.
5. To perform in terms of this agreement Mandatories must be familiar and conversant with the relevant provisions of the Occupational Health & Safety Act 85 of 1993 (OHS Act) and applicable Regulations.
6. Mandatories who utilise the services of their own Mandatories (contractors) must conclude a similar Written Agreement with them.
7. Be advised that this Agreement places the onus on the Mandatory to contact the CLIENT in the event of inability to perform as per this Agreement.
8. This Agreement shall be binding for all work the Mandatory undertakes for the client.
9. All documentation according to the Safety checklist including a copy of the written Construction Manager appointment in terms of construction regulation 8, must be submitted 7 days before work commences.

THE UNDERTAKING

The Mandatory undertakes to comply with:

INSURANCE

1. The Mandatory warrants that all their employees and/or their contractor's employees if any are covered in terms of the COID Act, which shall remain in force whilst any such employees are present on the Client's premises. A letter is required prior commencing any work on site confirming that the Principal contractor or contractor is in good standing with the Compensation Fund or Licensed Insurer.
2. The Mandatory warrants that they are in possession of the following insurance cover, which cover shall remain in force whilst they and /or their employees are present on the Client's premises, or which shall remain in force for that duration of their contractual relationship with the Client, whichever period is the longest.
 - a. Public Liability Insurance Cover as required by the Subcontract Agreement.
 - b. Any other Insurance cover that will adequately makes provision for any possible losses and/or claims arising from their and /or their Subcontractors and/or their respective employee's acts and/or omissions on the Client's premises.

COMPLIANCE WITH THE OCCUPATIONAL HEALTH & SAFETY ACT 85 OF 1993

The Mandatory undertakes to ensure that they and/or their subcontractors if any and/or their respective employees will at all times comply with the following conditions:

1. All work performed by the Mandatory on the Client's premises must be performed under the

- close supervision of the Mandatary's employees who are to be trained to understand the hazards associated with any work that the Mandatary performs on the Client's premises.
2. The Mandatary shall be assigned the responsibility in terms of Section 16(1) of the OHSAct 85 of 1993, if the Mandatary assigns any duty in terms of Section 16(2), a copy of such written assignment shall immediately be forwarded to the Client.
 3. The Mandatary shall ensure that he/she familiarise himself/herself with the requirements of the OHSAct 85 of 1993 and that s/he and his/her employees and any of his subcontractors comply with the requirements.
 4. The Mandatary shall ensure that a baseline risk assessment is performed by a competent person before commencement of any work in the Client's premises. A baseline risk assessment document will include identification of hazards and risk, analysis and evaluation of the risks and hazards identified, a documented plan and safe work procedures to mitigate, reduce or control the risks identified, and a monitoring and review plan of the risks and hazards.
 5. The Mandatary shall appoint competent persons who shall be trained on any Occupational Health & Safety aspect pertaining to them or to the work that is to be performed.
 6. The Mandatary shall ensure that discipline regarding Occupational Health & Safety shall be strictly enforced.
 7. Any personal protective equipment required shall be issued by the Mandatary to his/her employees and shall be worn at all times.
 8. Written safe working practices/procedures and precautionary measures shall be made available and enforced and all employees shall be made conversant with the contents of these practises.
 9. No unsafe equipment/machinery and/or articles shall be used by the Mandatary or contractor on the Client's premises.
 10. All incidents/accidents referred to in OHSAct shall be reported by the Mandatary to the Provincial Director: Department of Labour as well as to the Client.
 11. No user shall be made by the Mandatary and/or their employees and or their subcontractors of any of the Client's machinery/article/substance/plant/personal protective equipment without prior written approval.
 12. The Mandatary shall ensure that work for which the issuing of permit is required shall not be performed prior to the obtaining of a duty completed approved permit.
 13. The Mandatary shall ensure that no alcohol or any other intoxicating substance shall be allowed on the Client's premises. Anyone suspected to be under the influence of alcohol or any other intoxicating substance shall not be allowed on the premises. Anyone found on the premises suspected to be under the influence of alcohol or any other intoxicating substance shall be escorted off the said premises immediately.
 14. Full participation by the Mandatary shall be given to the employees of the Client if and when they inquire into Occupational Health & Safety.

FURTHER UNDERTAKING

1. Only a duly authorised representative appointed in terms of Section 16.2 of the OHS Act is eligible to sign this agreement on behalf of the Mandatary. The signing power of this representative must be designated in writing by the Chief Executive Officer of the Mandatary. A copy of this letter must be made available to the Client.
2. The Mandatary confirms that he has been informed that he must report to the Client's management, in writing anything he/she deems to be unhealthy and /or unsafe. He has versed his employees in this regard.
3. The Mandatary warrants that he/she shall not endanger the health & safety of the Client's employees and other persons in any way whilst performing work on the Client's premises.
4. The Mandatary understands that no work may commence on the Client's premises until this procedure is duly completed, signed and received by the Client.
5. Non-compliance with any of the above clauses may lead to an immediate cancellation of the contract.

ACCEPTANCE BY MANDATARY

In terms of section 37(2) of the Occupational Health & Safety Act 85 of 1993 and section 5.1(k) of the Construction Regulations 2014,

Ia duly authorised 16.2 Appointee acting for and on behalf of(company name) undertake to ensure that the requirements and the provision of the OHSAct 85 of 1993 and its regulations are complied with.

Mandatory – WCA/ Federated Employers Mutual No.....

Expiry date

SIGNATURE ON BEHALF OF MANDATARY
(Warrant his authority to sign)

DATE

SIGNATURE ON BEHALF OF THE CLIENT
AIRPORT COMPANY SOUTH AFRICA

DATE

PART C1: AGREEMENTS AND CONTRACT DATA

C1.5: ACSA INSURANCE CLAUSES

Each Party shall be responsible for effecting and maintaining the relevant insurances as specified below and to the extent relevant to the Contract.

1. Insurance Effected By The Employer (Principle Controlled Insurance (“PCI”))

- 1.1 Notwithstanding anything elsewhere contained in this Contract and without limiting the obligations, liabilities or responsibilities of the Contractor in anyway whatsoever (including but not limited to any requirement for the provision by the Contractor of any other insurances) the **Employer** shall effect and maintain for the duration of the construction and maintenance periods of the Contract - as appropriate in the joint names of the Employer, the Contractor and where relevant Sub-Contractors the following insurances which are subject to the terms, limits, exceptions and conditions of the Policy:

a) **Contract Works/Contractors Public Liability/ Removal Of Lateral Support Liability**

Section 1 Of The Policy – Contract Works

Contract Works Insurance for the full value of the Works to provide cover against accidental physical loss of or damage to the Works, Temporary Works and materials intended for incorporation in the Works all being the subject matter of this Contract including to the extent provided for in the policy whilst in transit or temporarily stored at any premises en route to or from the Site (other than where this is a continuation of Marine Transit) within the territorial limits of the policy.

This insurance may specifically exclude any cost necessary to replace or rectify any of the property insured, which is in a defective condition due to defect in design, plan specification, material or workmanship.

This insurance contains the following limitations and warranties ;

Open Trench Limitation

In respect of loss or damage to open trenches and pipes, conduits or cables laid therein, caused directly or indirectly by rain, inundation or flood, Insurers liability shall be limited in respect of the aggregate length of open trenches at any one time to 2,500 meters.

Exposed Layer Works (applicable to works involving paving, roadways, bulk earthworks and runways and taxiways)

In respect of loss or damage to Exposed Layer Works relating to paving, roadways and runways (including taxiways) caused directly or indirectly by rain, inundation or flood, Insurers liability shall be limited in respect of the aggregate length of Exposed Layer Works at any one time to 2,500 meters.

Section II of the Policy – Contractors Public Liability

Public Liability Insurance which provides indemnity against legal liability in the event of accidental death of or injury to persons and/or loss of or damage to property (other than the Works the subject matter of this Contract) arising from the execution of the Contract with a limit of indemnity of

R100,000,000 in respect of any one occurrence or series of occurrences consequent on or attributable to one source or original cause.

Section III of the Policy – Removal Of Lateral Support Liability

Removal Of Lateral Support Liability which provides indemnity against legal liability in the event of accidental death of or injury to persons and/or loss of or damage to property (other than the Works the subject matter of this Contract) arising out of or in connection with shock or vibration or the removal or weakening of or interference with support to property in the vicinity of the Contract Site and arising out of or in connection with the Insured Contract (but not in respect of tunneling works) and occurring during the Period of Insurance.

The Limit of Indemnity being limited to R50,000,000 attributable to one source or original cause

- b. Contract Works SASRIA** – Providing physical loss of or damage to the Works, Temporary Works and materials intended for incorporation in the Works as covered by the underlying Contract Works policy as noted in (a) above due to perils as covered in terms of the SASRIA Contract Works wording as issued by SASRIA SOC.

The Contract Works SASRIA cover excludes consequential or indirect loss or damage of any kind or description whatsoever.

The SASRIA Contract Works policy is limited to **R500,000,000 (Incl VAT)** in the aggregate during the policy period of insurance.

The Contract Works SASRIA policy wording can be obtained from the SASRIA website <http://www.sasria.co.za/> which notes the covers and policy exclusions.

- c) Aviation Liability Insurance** which provides indemnity against legal liability in the event of accidental death of or injury to persons and/or loss of or damage to property (other than the Works the subject matter of this Contract) arising from the execution of the Contract with a limit of indemnity of **R2,000,000,000** in respect of any one occurrence or series of occurrences consequent on or to one source or original cause.

This insurance is in respect of liability relating to aircrafts.

- d) Design & Construct Professional Indemnity Insurance** which provides indemnity against legal liability to pay compensation as a result of any actual or alleged negligent act, error or omission in the performance of the Professional Duties of the insured and arising from the execution of this project. The limit of indemnity under this insurance shall be ***R25,000,000 in the aggregate during the annual policy period of insurance that ACSA effect such cover during the policy period from 1 April to 31 March during each policy period of insurance.**

****The limits of indemnity applies to all ACSA contracts as a whole and does not apply specifically to this contract. The aggregate limit could be exhausted by claims under other ACSA contracts and there is no guarantee that this insurance cover will provide sufficient cover to this specific contract should the aggregate limit be exhausted.***

The Policy only covers the rectification of the works and excludes all consequential losses.

Professional Duties do not include:

- a) Labour and construction work which would normally be the responsibility of the building or engineering contractor.
- b) Supervision of the construction works usually undertaken by a building or engineering contractor.

1.2 The **Contractor** shall familiarise itself fully with the details of such insurance effected by the Employer. The Contractor shall comply to all the terms and conditions of the Employer arranged policies and the Contractor shall be deemed to be fully aware of all the conditions, limits, limitations, exclusions/exceptions and deductibles that are contained in the Employer arranged policies. Copies of the Employer arranged policies are obtainable on request from the Employer and if the Contractor is of the opinion that additional insurance is required, such shall be for the Contractors account.

1.3 The Employer shall pay the premium in connection with the insurances effected by the Employer. The Employer is entitled to all return premiums, dividends, discounts, or adjustments in connection with the insurances effected by the Employer.

1.4 The Contractor shall not include any premium charges for this insurance except to the extent, which he may deem necessary in his own interests to effect supplementary insurance to the insurance effected by the Employer. The Employer reserves the right to call for full information regarding insurance costs included by the Contractor.

In the event that the Contractor purchases any insurances in addition to those indicated above, the premium and taxes, duties, etc. shall be borne entirely by the contractor.

1.5 Any further clarification of the scope of cover provided by the Policies arranged by the Employer should be obtained from the Employer.

1.6 The Contractor and/or any other party who obtains indemnity under the policies effected under 1.1 shall become liable for the deductibles (first amount payable) which are applicable in respect of each and every occurrence or series of occurrences attributable to one source or cause giving rise to loss or damage or indemnifiable liability. The deductibles applicable to the policies effected under 1.1 are as follows:

a) Contract Works/Contractors Public Liability/ Removal Of Lateral Support Liability

Unless stated otherwise in the Policy Extensions the Deductibles shall be as follows which will apply in respect of each and every occurrence or series of occurrences arising out of or in connection with any one event giving rise to loss or damage:

Section 1 Of The Policy – Contract Works

In respect of all loss or damage **R150,000** but increased to **R250,000** in respect of loss or damage arising out of or in connection with testing and commissioning.

Section 2 Of The Policy – Contractors Public Liability

R75,000 each and every claim in respect of Property Damage.

Section 3 Of The Policy – Removal Of Lateral Support Liability

R75,000 each and every claim.

b) Contract Works SASRIA

In respect of theft as a result of the SASRIA perils insured - **R25,000** each and every occurrence

c) Aviation Liability Insurance ;

In respect of each and every loss or damage or injury - **US\$250,000**.

d) Design & Construct Professional Indemnity Insurance

a) In respect of contracts under R50 million at award – **R5,000,000**.

b) **In respect of contracts over R50 million at award – R10,000,000**

1.7 In the event of any occurrence which is likely to give rise to a claim under the insurance arranged by the Employer, the Contractor shall:

- a) In addition to any statutory requirement or other requirements contained in the Contract immediately notify the Employer and the Employer's Insurance Brokers by telephone, mobile phone or email giving the circumstances, nature and an estimate of the loss or damage or liability. The Contractor must also complete the Claim Advice Form (Appendix "A").

The following persons/insurers must be advised immediately on the occurrence of a claim on site or even a possibility of a claim arising due to an incident occurring on site:

Airports Company South Africa :
Johnson Mji

- b) Preserve damage and make it available for inspection by a representative of the Insurers.
- c) Wherever possible, photographs of damage should be taken.
- d) Inform the police authorities promptly in the event of loss or damage by theft, burglary or any malicious persons(s) for the purpose of recovering any property so lost, discovering the guilty person or persons, and having him, her or them duly prosecuted.
- e) Advise the Insurers of any other insurance(s) which may cover the same loss, damage or injury, or any part thereof.
- f) Give to the Insurers every assistance to enable the Insurers to settle or resist any claim against the Insured, or institute any proceedings;
- g) On completion the Claims Advice Form, the form must be sent to the Employers Insurance Brokers for further action (the original may be emailed to the Employers Insurance Broker). (Please do not remove the Claims Advice Form out of this document. Rather photocopy the form and send the copy to the Employers Insurance Brokers).
- h) The Employer and the employers Insurance brokers / Insurers or their appointed loss adjusters shall have the right to make all and any enquiry's on the Site of the Works or elsewhere as to the

cause and results of any such occurrence and the Contractor shall co-operate in carrying out such enquiry's.

- i) The Contractor, Project Managers and Consultants must allow free access to Insurers' assessors for the purpose of investigating and assessing the loss or damage.
- j) The Contractor must not proceed with the making good any off the loss without the prior authorisation of the Insurers.**
- k) The Contractor must keep separate records of the costs involved in making good any loss or damage and these records should be available at all times for inspection by Insurers. Such records should include inter alia the entire cost of labour, materials, transport and equipment.
- l) Where required by the Employer, negotiate the settlement of claims with the Insurer or their appointed loss adjusters through the Employer's Insurance Brokers and shall obtain the Employer's approval of such settlement.
- m) Once the amount of a claim is agreed by the Insurers and the Contractor, an "Agreement of Loss" form must be signed by the Contractor and if required this shall be counter signed by the Employer or the Project Managers.
- n) The proceeds of such claim will, if required by the Employer, be paid net of any Deductible applicable under the policy by the Insurers to the Employer who on receipt thereof will arrange for payment to be made in terms of the Conditions of Contract. In the event that it is agreed by the Employer that such claims payment be made directly to the Contractor, the Contractor shall arrange for the Employer to endorse the "Agreement of Loss" to this effect.

2. Insurance Effected by the Contractor.

In addition to Clause 1.1 in respect of the insurances effected by the Employer the following Insurances to be effected by the Contractor :

2.1 Without limiting the Contractor's obligations, responsibilities and liabilities, the Contractor and Sub-contractor shall maintain at the Contractor's and Subcontractor's expense and where applicable provide as a minimum the following insurances:

- a) **Insurance of Construction Plant and Equipment** (including tools offices and other temporary structures and contents) and other things (except those intended for incorporation into the Works) brought onto the site for a sum sufficient to provide for their replacement.

The Employer shall be named as additional insured and a waiver of subrogation shall be provided to the Employer.

- b) **Contractor's Common Law Liability/ Worker's Compensation Insurance**

The Contractor shall take out and maintain employer's liability insurance with a limit of indemnity of not less than **R20,000,000** and/or workmen's compensation insurance covering personal injury to or death of the employees of the Contractor engaged in connection with the Works to the minimum value required by applicable law.

The Contractor shall procure that its Subcontractors take out and maintain similar insurance in respect of its Subcontractor's personnel performing the Works.

In the event that a claim is made against the Employer in connection with such insurance, the Contractor shall indemnify and hold harmless the Employer against any such claim. The Employer shall be named as additional insured and a waiver of subrogation shall be provided to the Employer.

- c) **Motor Vehicle Liability Insurance** comprising (as a minimum) "Balance of Third Party" Risks including Passenger Liability indemnity with a limit of indemnity of not less than **R5 000 000** for all owned, non-owned, leased and hired vehicles.

- d) **Insurance For Buy-Down Cover Of Employer's Deductibles**

Should the Contractor believe that the Employer effected Contract Works, Public Liability and Design & Construct Professional Indemnity deductibles as noted in Clause 1.6 (a),(c) and (d) be considered to be unacceptable to the Contractor, then the Contractor must obtain Buy Down cover for these deductibles to a deductible considered by the Contractor as being acceptable in respect of the works being undertaken.

- e) Where the Contract involves manufacturing and/or fabrication of the Works or parts thereof at premises other than at the Contract Site the Contractor shall satisfy the Employer that all materials and equipment for incorporation in the Works are adequately insured during manufacture and/or fabrication. In the event of the Employer having an insurable interest in such Works during manufacture or fabrication then such interest shall be noted by endorsement to the relevant Policies of Insurance.

Such insurance shall name Employer as an additional insured, and shall be primary to any insurance maintained by the Employer.

- f) **Public Liability** insurances in excess of the Employers Public Liability insurances as stated under clause 1.1(a).
- g) **Aviation Liability** insurances in excess of the Employers Aviation Liability insurances as stated under clause 1.1(c).
- h) **Contractor's Professional Indemnity Insurance** in excess of the Employers Design & Construct Professional Indemnity insurances as stated under clause 1.1(d) and if applicable to cover the deductible that applies to the Employer effected insurance.

- i) **Marine Cargo Insurance (If Applicable)**

Cover : Imports of cargo, equipment, goods, plant, machinery and materials ("**Insured Property**") to the site where the Permanent Works will be constructed.

Sum Insured: Not less than the value of the largest single cargo shipment, conveyance or the value in storage, whichever is the greater (CIF plus 10%).

Marine / Air Cargo Insurance covering the Insured Property against all risks of physical loss or damage while in transit by land, sea or air from country of origin anywhere in the world to the site where the Permanent Works will be constructed including loading, or vice versa, from the commencement of the time the insured items are loaded prior leaving the warehouse or factory for shipment to the said site.

The insured parties are the Employer, the Contractor and its Subcontractors, and all their personnel involved in the execution of any Works on the construction site.

j) Miscellaneous Insurance

Other insurance as is customary, desirable or necessary to comply with applicable Laws in the Country.

- 2.2 The insurances to be provided by the Contractor and his Sub-contractor shall be effected with Insurers and on terms approved by the Employer (which approval shall not be unreasonably withheld) and shall be maintained in force for the duration required (including any period of maintenance/defects liability period). The Contractor shall within twenty eight (28) days of commencement of the contract produce to the Employer the relevant Policy or Policies of Insurance.
- 2.3 In the event that the Contractor or his Sub-contractor receives any notice of cancellation or restrictive modification to the insurance provided to them they shall immediately notify the Employer in writing of such cancellation or restriction and shall advise what action the Contractor or his Sub-contractor will take to remedy such action.

If the Contractor fails to effect and keep in force the insurances referred to then the Employer may effect and keep in force any such insurances and pay such premium or premiums as may be necessary for that purpose and from time to time deduct the amount paid by the Employer from any monies due or which may become due to the Contractor or recover same as a debt from the Contractor.

2.4 Sub-Contractors.

The Contractor shall:

- a) ensure that all potential and appointed Sub-contractors are aware of the whole contents of these Insurance Clauses, and
- b) enforce the compliance by sub contract agreement between the Contractor and Sub-Contractor and where applicable that the Sub Contractor effect similar insurance relating to the insurances required to be effected by the Contractor under Clause 2 (Contractor effected insurances).

Pricing Schedule 1 - Provisional Amounts

Items	Price
Safety File (Safety, OHS Act compliance, medicals, safety, training)	R 7 000,00
Permits and Induction (Based on proven costs, no markup)	R 13 000,00
Airside Vehicle Compliance (Branding, Amber Light, Reflective Strip)	R 5 000,00
Contingencies (Based on proven and approved costs)	R 75 000,00
Total	R 100 000,00

Pricing Schedule 2

Parts (Supply the following pumps. Minimum technical specifications provided in Scope of works)	Unit	Qty	Unit Price	Price
7.5Kw, 3 phase submersible pump	ea	2	R	R
Car Rental, Sewer, submersible pumps, 3.7kW	ea	4	R	R
Basement Sewer Depot and Delivery Gate (Landside), submersible pump 3.7kW	ea	3	R	R
Stormwater Submersible Pumps, 11kW	ea	6	R	R
Sewage Grinder (Macerator), motor size 3.7kW	ea	2	R	R
Other required materials (sprays, cables, bolts and nuts, etc.)	sum			R
Total				R

Pricing Schedule 3			
Items			Price(R)
Car Rental depot northern	ea	1	
Car Rental depot southern	ea	1	
Delivery gate	ea	1	
Basement north	ea	1	
Basement south	ea	1	
Basement plant room	ea	1	
Airside dump facility	ea	3	
Electrical	sum		R

Pricing Schedule 4

Items	Price (R)
Decommissioning of existing pumps	R
Installation of new pumps	R
Testing & Commissioning	R
Compliance Certificates	R

Total	R
--------------	---

Note: Labour price to include PPE, Tools, travelling and accommodation.

Pricing Schedule 5

Items	Price (R)
Rigging Equipment	R
Total	R

Pricing Schedule 6

Items	Rate per Litre (R)
Honeysucker 6	R

Pricing Summary	Price
Pricing Schedule 1	R 100 000,00
Pricing Schedule 2	R
Pricing Schedule 3	R
Pricing Schedule 4	R
Pricing Schedule 5	R
Pricing Schedule 6	R
Total Excluding Vat	R
VAT @15%	R
Total Including Vat	R

ADHOC LABOUR RATES

- Note: *These costs are for Information purposes*
- Bidders to provide following labour rates that will be applied to adhoc works.
- This is not to be included in the Pricing Schedules.
- All rates to exclude vat. Subject to agreement between the Employer and the Contractor, the number of staff allocated may be increased/decreased to cater for special needs that may arise from time to time.
- Labour rates shall include *travelling, accommodation, admin and fees on overheads, PPE, tools allowances, all per diem and incentive bonuses.*

Items	Rate per Hour (R)
-------	-------------------

Technician (Millwright/Fitter)	R
Technical Assistant	R

Items	Rate per Litre (R)
Honeysucker	R

Markup	
Indicate % Mark-up on 3 rd party procured items and services	
Value of items or services	% Mark-up
R1.00 – R5000.00	
R5001.00 - R 10 000.00	
R10 001.00 – R50 000.00	
R50 001.00 – R100 000.00	

PART 3: SCOPE OF WORK

Document reference	Title	No of pages
C3.1	This cover page	1
C3.2	<i>Employer's Works Information</i>	
	<i>Contractor's Works Information</i> ³	
	Total number of pages	

Develop Scope of Work using guidance provided .Note that this document is merely a guideline of what to include in the scope of work. The contract manager will be required to apply his / her mind and delete or add any information required, depending on the nature of the works. Where the contract requires information to be included in the scope of works, the relevant heading will contain a footnote indicating that the information is compulsory. Complete this document by replacing the guidance notes in [square brackets] with the relevant information. When the document is complete, delete this note and ALL footnotes.

*For further guidance refer to guidance notes on CIDB website:
http://www.cidb.org.za/procurement/procurement_toolbox/overview/contract_sec/default.aspx*

³ Insert at award stage or delete if not applicable. Delete this note once a selection is made.

TABLE OF CONTENTS

Clause number and description	Page
Part 3: Scope of Work.....	115
C3.1: Employer's works Information.....	2
1. Description of the <i>works</i>	62
2. Contract Management	2
3. Engineering and design of the <i>works</i>	5
4. Procurement	6
5. Construction.....	7
6. Plant and Materials standards and workmanship.....	10
2. List of drawings.....	11
C3.2 <i>Contractor's Works Information</i>	62

C3.1: EMPLOYER'S WORKS INFORMATION

1. Description of the works

The objective of this scope is to source a suitable service provider for decommissioning the existing Submersible Pumps; supply and install new submersible pumps; at King Shaka International Airport.

2. Background

Submersible pumps are designed to operate beneath ground level. A submersible pump is designed to be completely submerged in liquid and then deliver the liquid to the surface.

There is a need for replacement of submersible pumps - as they are nearing the end of their Lifecycle, they now require repairs at higher intervals. This has reduced asset availability. These pumps experiences burning of windings on the motor stator, and the continuous bearing failure.

3. Interpretation and terminology

Abbreviation	Meaning given to the abbreviation
ACSA	Airports Company South Africa SOC Limited
KSIA	King Shaka International Airport
OEM	Original Equipment Manufacturer
BOQ	Bill of Quantities
WWTP	Wastewater Treatment Plant
TMB	Terminal Building

4. Contract Management

Management meetings⁴

The Contractor will be expected to attend meetings relating to the project, maintenance, operations, contract management and other issues that may arise from time to time. As far as is practicable, the Contractor will make all required persons available for these meetings. The Contractor shall not submit claims for payment for staff attending any of these meetings.

Health and safety risk management

- (i) The Project Manager shall be entitled to fine the *Contractor* low service damages for each non-conformance to Health and Safety matters. This shall not transfer any of the Contractor's responsibilities in this regard to the Employer by any means.

⁴ The information in this section is required by the contract. Do not delete.

- (ii) The Contractor shall be fully responsible for compliance to the Occupational Health and Safety Act for all persons, equipment and installations relating to this Contract. The Contractor is expected to sign the undertaking in this regard as attached in the annexes.
- (iii) It shall be the Contractor's responsibility to ensure that all relevant labour and safety legislation is adhered to in rostering staff.
- (iv) All persons on company premises shall obey all health and safety rules, procedures, and practices. NO SMOKING signs and the prohibition of the carrying of smoking materials in designated areas shall always be obeyed. A copy of the Safety Rules booklet is available on request from the ACSA Safety Department.
- (v) All the applicable requirements of the Occupational Health and Safety Act (1993) and Regulations and any amendments thereto, shall be met. Where the OHS, Act prescribes certification of competency of persons performing certain tasks, proof of such certification shall be provided to the Project Manager.
- (vi) The Contractor's Workmen's Compensation fees must be up to date. A copy of the Contractor's WCA registration shall be produced on request. The following areas in the company are declared as "HOT WORKS PERMIT" areas:
 - All airside areas
 - All basement areas
 - All areas accessible to the public
 - All enclosed areas
 - The terminal building
- (vii) Any process in the above-mentioned areas involving open flames, sparks, or heat shall be authorised by the issue of a permit to work - obtainable from the ACSA Safety department. Any work done under the protection of a permit to work shall be in strict compliance with every prescription regarding the permit.
- (viii) Safety equipment shall be used where applicable (e.g. safety, goggles, boots, harness, etc.) The Contractor, at his/her own expense shall provide such equipment, for his/her employees. The Contractor shall apply the necessary discipline and control to ensure compliance by his workers.
- (ix) All Contractors must ensure that his/her employees are familiar with the existing emergency procedures and must co-operate in any drills or exercises, which might be held. Emergency / fire equipment and extinguishers shall not be obstructed at any time.
- (x) No person shall perform an unsafe / unhygienic act or operation whilst on Company premises.
- (xi) No unsafe/dangerous equipment or tools may be brought onto or used on Company premises. The Company reserves the right to inspect all equipment/tools at any time and to prevent/prohibit their use, without any penalty to the Company and without affecting the terms of the Contract in any way.
- (xii) The Company reserves the right to act in any way to ensure the safety/security of any persons, equipment or goods on its premises and will not be liable for any costs or loss evoked by the action. This includes the right to search all vehicles and persons entering, leaving or on the premises and to inspect any parcel, package, handbag, and pockets. Persons who are not willing to permit such searches may not bring any such items or vehicles onto the premises.
- (xiii) The Contractor shall maintain good housekeeping standards in the area where he is working for the duration of the contract.
- (xiv) At no time, must the Contractor interfere with, or put at risk, the functionality of any Sprinklers and/or fire prevention system. In cases where the project is for the replacement or refurbishment of the Sprinkler System, care must be taken to prevent fire hazards.

- (xv) The Contractor is required to issue all staff with standard uniforms. This shall as a minimum include steel-tipped safety shoes/boots, overalls (clearly marked with Contractor's company logo) and numbered reflective jackets (also clearly marked with Contractor's company logo, the team members unique personnel number in a font size to be instructed by the Project Manager). All costs relating to uniforms shall be for the Contractor's account.

Environmental constraints and management

The Contractor will keep noise and dust levels to a minimum. At no time, shall his/her work result in nuisance, interference, or danger to the public or any other person working at the Airport.

At no time, shall the Contractor:

- allow any pollutive or toxic substance to be released into the air or storm water systems
- interfere with, or put at risk, the functionality of any system or service
- cause a fire or safety hazard

Quality assurance requirements

Within the period stated in the Contact Data, the *Contractor* submits his complete quality control and assurance system (with all quality control and assurance procedures and manuals) for review and acceptance by the *Employer*. The manual includes pro-forma checklists for all requirements of the *Contractor's* quality control and assurance program and those called for in the Scope.

Acceptance by the *Employer* of the *Contractor's* quality assurance programme, quality plans and/or inspection and/or test plans, or of those of his Subcontractors will not relieve the *Contractor* of his obligation to provide services which meet the requirements of the Contract.

Programming

The *Contractor* shall provide the project schedule to the Project Manager, detailing all key dates to the projects, i.e., forecast start, forecast finish etc.

The *Contractor's* Personnel

Key Personnel (Minimum):

Millwright
Technical Assistant

Insurance provided by the *Employer*

Refer to C1.5 ACSA Insurance Clause

Provision of bonds and guarantees

Without limitation to the Employer's rights under the Contract, the *Employer* may withhold payment of amounts due to the *Contractor* until the bond or guarantee required in terms of this contract has been received and accepted by the person notified to the *Contractor* by the *Project Manager* to receive and accept such bond or guarantee. Such withholding of payment due to the *Contractor* does not affect the *Employer's* right to termination stated in this contract.

Records of Defined Cost, payments & assessments of compensation events to be kept by the *Contractor*.

Training workshops and technology transfer

Technology Transfer: transferring new knowledge and technology developed at the through the installation of the new Submersible Pumps to the Employer (ACSA) who can realise value from them by making them available to the facility custodians for operations.

Transfer of Information (Contractor to Employer) and Basic Training to use the system is required at commissioning and handover

5. Engineering and design of the works

Contractor's design

N/A

Equipment required to be included in the works⁵

Contractor to supply own tools and equipment required to execute the works.

As-built drawings, operating manuals and maintenance schedules

⁵ **The information in this section is required by the contract. Do not delete.**

Handover Documentation OEM Service Manuals, Operational Manuals, Maintenance Manuals & Drawings will be submitted and approved by the Project Manager prior to acceptance.

6. Procurement

The Contractor will respect OEM warranties to the Employer always when procuring spare parts, products, or 3rd party services. It will be the Contractor's sole responsibility to ensure that OEM warranty requirements are adhered to always.

Where the Contractor uses or quotes on spare parts of a lower quality than recommended by the OEM, or parts not recommended by the OEM, this shall be clearly indicated to the Project Manager on the quotation. This also implies that the Contractor must build relationships with the various key OEM's.

The Contractor must adhere to all airport requirements regarding fire, health and safety when procuring pumps and/or other equipment or spares.

No casual labour (i.e. "off the street" labour) may be employed by the Contractor unless pre-arranged with the Employer. Whenever this is required, the Contractor shall come to a suitable arrangement with the Employer regarding sourcing and screening of such individuals.

Personnel:

Minimum requirements of people employed on the Site

A schedule of key personnel to this Contract (as per the Schedules) will be provided to the Project Manager at commencement of this Contract. This will, as a minimum, include all persons from technician level to management level. For the full duration of this Contract, none of these persons will be replaced by a person of lesser ability or qualification. All on-site staff leaves shall be reported and agreed with the Project Manager

Subcontracting

No part of this Contract may be subcontracted unless with written approval from the *Employer*. the *Employer* shall be under no obligation to grant such approval. Should any part of this Contract be subcontracted, the *Contractor* will be responsible for all Works (or failure to affect the Works) as if it were done so by the *Contractor*.

Limitations on subcontracting

The Contractor may not subcontract more than 20% of the Works.

Construction

The *Contractor* must accept and respect the fact that the Airport is continuously undergoing construction and improvement and that a variety of stakeholders are involved in the Employer's business. Therefore, within reason and with prior arrangement with the *Contractor*, the Employer might require the following from time to time:

- Assisting with airport operations Re-scheduling of work to accommodate other contractors
- Allowing access and aiding OEM suppliers to correct defects on equipment and/or systems
- Communicating with current service provider in order to reduce risk to passenger loading bridges
- Providing access to other contractors
- Removing scrap from site
- Recommending improvements on maintenance procedures
- Safe / legal disposal of used and irreparable spares

The Project Manager may instruct operational and works procedures to the *Contractor* as might be required from time to time. The *Contractor* will instruct his/her staff accordingly and implement measures to ensure that these procedures are strictly adhered to.

Employer's Site entry and security control, permits, and Site regulations

The *Contractor* shall not be compensated for costs relating to the Employer's required permits, or for labour/time spent in obtaining it. An allowance must be made in the Activity Schedule in this regard.

The *Contractor* must ensure that he/she is, always, familiar with the Employer's safety and security requirements relating to permits for no work to be delayed as a result thereof. This will include the permit application process.

Note that (within reason) the *Contractor* will have no claim against the Employer if a permit request is refused.

The following table is not all inclusive, but is provided for illustration purposes:

Permit	Required by/for	Department
AVOP – Airside Vehicle Operator permit	All drivers of vehicles on airside	ACSA Safety
Airside Vehicle Permit	All vehicles that enter airside	ACSA Safety
Basement Parking permit	All vehicles allowed to enter the delivery basement	ACSA Parking
Personal permit	All persons employed on the airport	ACSA Security
Cell phone permit	All persons taking cell phones to airside	ACSA Security
Lap top permit	All persons taking lap top computers to airside	ACSA Security
Camera permit	All persons taking cameras or camera equipment to airside	ACSA Security

Hot Works Permit	All welding and/metal cutting work	ACSA Safety
------------------	------------------------------------	-------------

Proof of having attended the airside induction training course is required for all personal permit applications. Persons applying for an AVOP must provide proof of having attended an AVOP course. Fees are levied for these courses. Fees are further levied for all permit renewals and refresher courses - where applicable

Vehicle Permit (Permanent permits – for the duration of the project):

- The disc must be up to date
- Public Liability Up to date
- Vehicle certificate of Registration
- Ensure that the lifespan of the vehicles (Light commercial passenger vehicles (up to twelve (12) passengers)) does not exceed the following limits: maximum age eight (8) years
- Reflective strip on the vehicle 80% covered
- Decal x3 - one on the left and right front doors and one on the top (font size min 200mm high). Code can be the first three letters of the company name – Eg. For ACSA Vehicles Code can be **AC 01**
- Strobe light.
- The regular driver would need to have an AVOP on their permit when we complete the vehicle permits after the above has been sorted.

Equipment provided by the *Employer*

The Employer is in under no obligation provide any equipment for the contractor the contractor is to provide their own tools and equipment to execute the works.

Site services and facilities provided by the *Employer*⁶

Employer will provide power, water, waste disposal and ablutions.

site conditions and requirements

The Contractor will keep noise and dust levels to a minimum. At no time, shall his/her work result in nuisance, interference, or danger to the public or any other person working at the Airport.

At no time, shall the *Contractor*:

- allow any pollutive or toxic substance to be released into the air or storm water systems
- interfere with, or put at risk, the functionality of any system or service
- cause a fire or safety hazard
- cause traffic with airport users

The *Contractor* will be required to do housekeeping and will be required to clear site and dispose of old material.

⁶ **The information in this section is required by the contract. Do not delete. If it does not apply, delete the notes in italics and substitute the words ‘Not applicable’, but ALWAYS state “the Contractor shall provide everything else necessary for Providing the Works”.**

Construction requirements

Installation and decommissioning procedure to be provided by the *Contractor* and approved by the *Employer (Project Manager)*. The program to clearly show sequence of activities, timelines, and resource allocations.

Completion, testing, commissioning and correction of Defects

Work to be done by the Completion Date⁷

All work is to be done by the Contractor shall be completed by the Completion Date as per the program of activities as agreed by the *Contractor* and *Project Manager*.

The *Project Manager* cannot certify Completion until all the work except that listed above has been completed and is also free of Defects which would have, in his opinion, prevented the *Employer* from using the *works* and Others from doing their work.

Use of the *works* before Completion has been certified⁸

N/A

Materials facilities and samples for tests and inspections

N/A

Commissioning

To be conducted after installation and successful testing of the system.

Start-up procedures required to put the *works* into operation

Contractor to submit methodology to Project Manager for Approval of start-up procedures.

Take over procedures

Final handover from the *Contractor* to the *Project Manager* to be done once all the works have been completed as per the Scope of Works and agreed upon.

Access given by the *Employer* for correction of Defects⁹

⁷ The information in this section is required by the contract. Do not delete.

⁸ The information in this section is required by the contract. Do not delete. If it does not apply, delete the notes in italics and substitute the words 'Not applicable'.

⁹ The information in this section is required by the contract. Do not delete. If it does not apply, delete the notes in italics and substitute the words 'Not applicable'.

Permit approvals will be arranged by the *Employer* for defects that need to be resolved by the *Contractor*.

Performance tests after Completion

Contractor to submit methodology to Project Manager (prior to installation) for Approval of Testing procedures

Operational maintenance after Completion

N/A

PLANT AND MATERIALS STANDARDS AND WORKMANSHIP

Plant & Materials provided “free issue” by the Employer

Site clearance/Grass Cutting

7. LIST OF DRAWINGS

1.1. Drawings issued by the *Employer*

[This is the list of drawings issued by the Employer at or before the Contract Date and which apply to this contract]

Drawing number	Revision	Title

C3.2 CONTRACTOR'S WORKS INFORMATION

Description of the works

The contractor will be responsible for the replacement of submersible pumps.

Submersible pumps are designed to operate beneath the earth's surface. A submersible pump will not work unless it's completely submerged in liquid. Unlike an above ground pumping system, which sucks water out of the ground, a submersible is designed to push water to the surface.

King Shaka International Airport has 15 submersible pumps in total, there`s two pumps at the North Waste water treatment plant, two pumps at South waste water treatment plant also there is two at the south car rentals, two at the North car rentals, two at the Basement North(Stormwater), Two at the Permit office basement tunnel and also there`s two at the Basement south(Stormwater), Two at the basement plant room one, there is one pump at basement entry Delivery gate. Additionally, to the Submissible pumps there are 2 Macerators at the Dumping facility (Airside). All these pumps play a significant role to pump wastewater and storm water from the Terminal basement and other areas around KSIA to the designated treatment plant.

The scope of work includes:

- Decommissioning of the existing submersible pumps and handing them over to ACSA(Find out from Finance if there is a disposal process that can be included in the bid document and be part of the project).
- Decommission old control panels
- Removal of existing guide rails, duck foot couplings, and chains
- Installation of guide rails, duck foot couplings, and chains
- Supply and install new control panels

- Supply of fifteen 3 phase submersible pumps with ultrasonic level sensors, two macerator pumps. (Get confirmation if all our pumps require 3 phase power) IAM to action
- Installation of fifteen 3 phase submersible pumps with ultrasonic level sensors, two macerator pumps.
- The scope includes all pipe work, sprays and fittings. (How is it going to be priced? Please check)
- The scope includes all electrical installation, connection and commissioning thereof and provision of the Certificate of compliance (COC)
- Testing and commissioning
- Handover

Emptying of pits:

- Wastewater pits to be emptied and carting to South Wastewater Treatment Plant (SWWTP).
- For pumps at the SWWTP, potable submersible pump is required to serve as a contingency to pump into SBRs to avoid overflow during the replacement.

Specification of Pumps

Location	Pump	Make	Model	Power	Voltage
SWWTP (Landside)	2	Grundfos	Submersible	7.5 kW	380V
Northern Car Rental Sewer Depot (Landside)	2	HCP Pump	AF-35A	3.7 kW	380V
Southern Car Rental Sewer Depot (Landside)	2	HCP Pump	AF-35A	3.7 kW	380V
Basement Plant room 1 (Landside)	2	Jung Pumpen	UFK 35/2.AW.Y3	3.7 kW	380V
Delivery Gate Entry Pump (Landside)	1	Jung Pumpen	Submersible	1.8kW	240V
Basement North Storm Water Pumps (Landside)	2	HCP Pump	Submersible	11 kW	380V
Basement South Storm Water Pumps (Landside)	2	HCP Pump	Submersible	311 kW	380V
Permit office basement tunnel Pumps (Landside)	2	Jung Pumpen	Submersible	0,75 kW	240V
Dumping Facility Macerator (Airside)	2	Muffin Monster	Macerators	3kW	380V

Technical Specification

The following are the drawings and pump curves of the existing submersible pumps. This is for illustration purpose only; measurements are to be done and confirmed by the bidder. All dimensions are in millimetres.

1. Grundfos 7.5kW 3 phase pumps

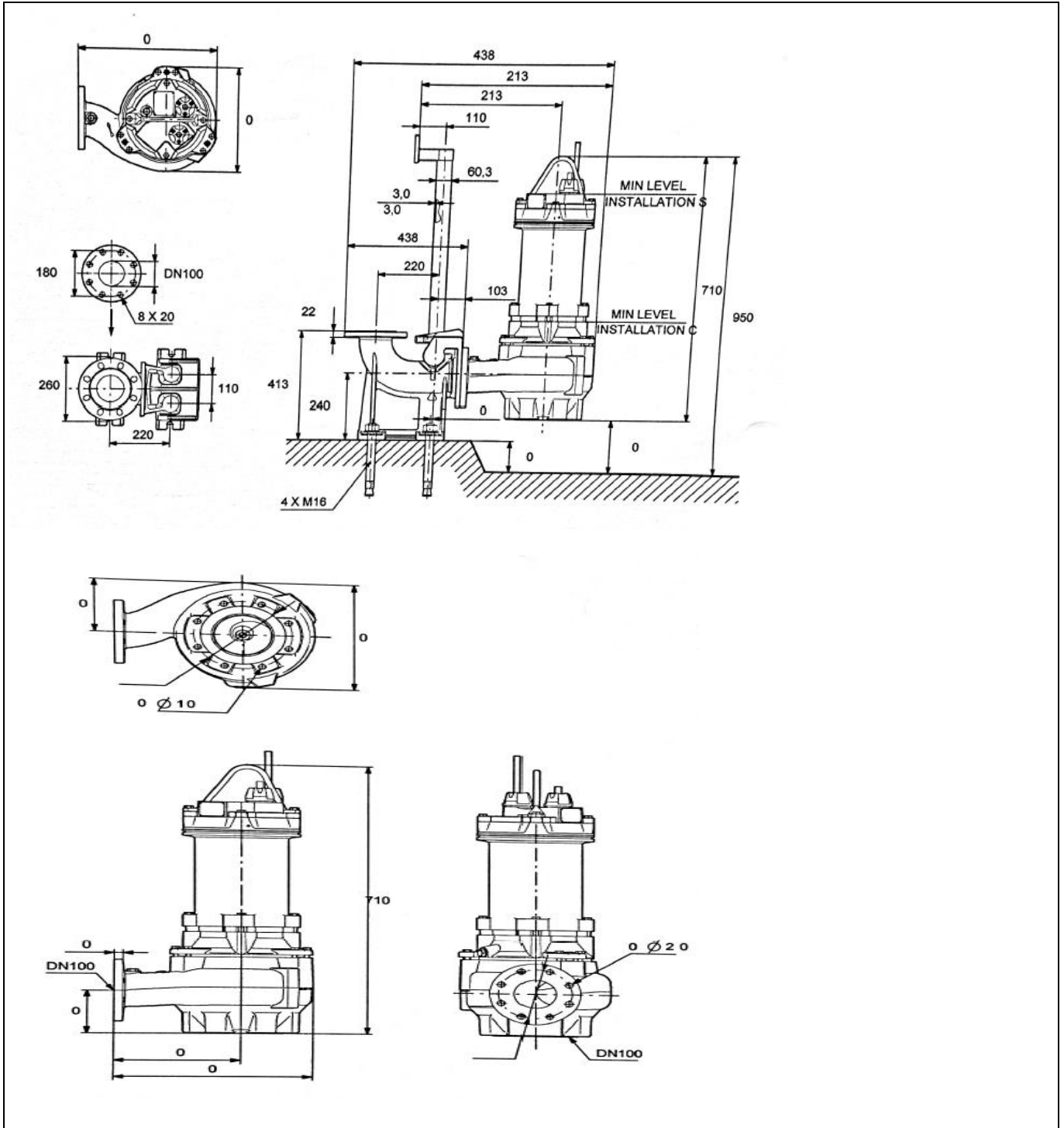

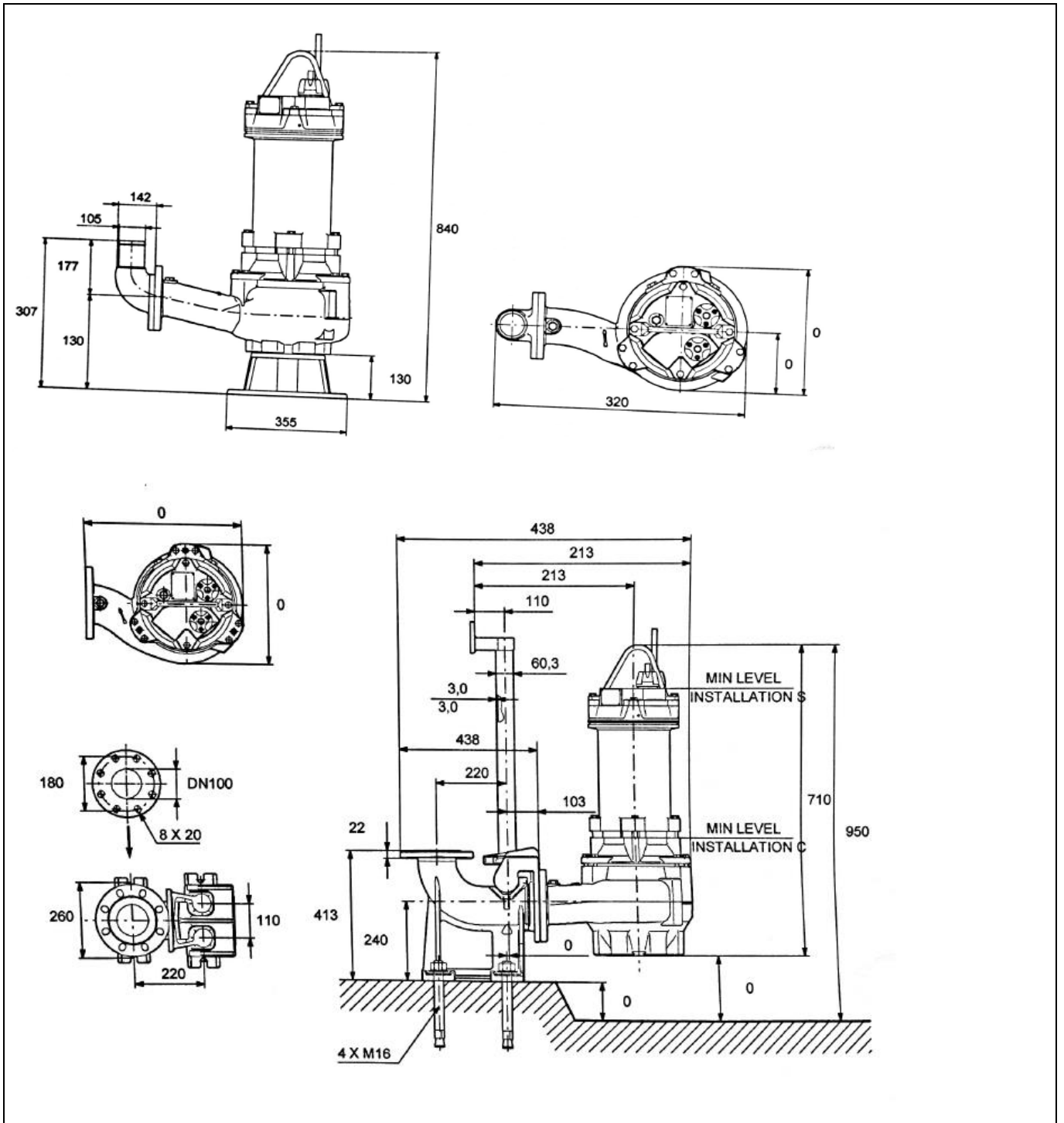

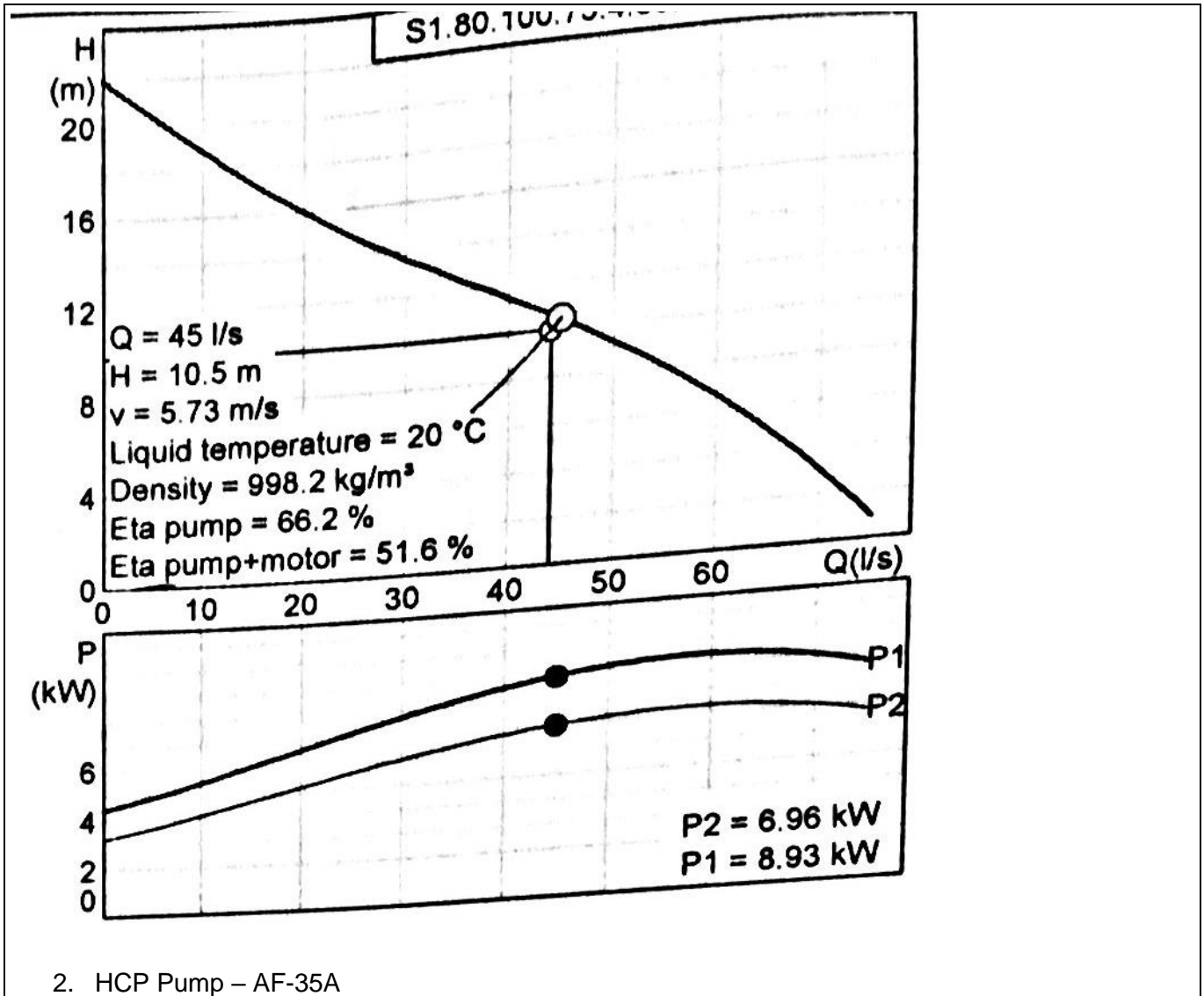

2. HCP Pump – AF-35A

PERFORMANCE SPEC.

Pole	Model	Power HP (kW)	Discharge Inch (mm)	Phase Ø	Start Method	Head m	Capacity m³/min	Head feet	Capacity GPM	Weight kg (lb) 10/30	solid passage mm	Dimension (mm)		
												Length	Width	Height
2P	50AFU2.4	0.5(0.4)	2"(50)	1 3	Capacitor Direct	5.5	0.15	18	40	20(44) 20(44)	35	236	152	418
	50AFU2.8	1(0.75)	2"(50)	1 3	Capacitor Direct	8	0.2	26	54	21(46) 21(46)	35	236	152	418
	AF-15AU	2(1.5)	3"(80)	1 3	Capacitor Direct	5	0.5	16	132	42(92) 40(88)	46	412	250	595 547
	AF-33U	3(2.2)	3"(80)	3	Direct	9	0.5	30	132	42(92)	46	412	250	570
	AF-35A	5(3.7)	3"(80)	3	Direct	15	0.5	50	132	58(128)	56	478	220	588
	AF-15AP	2(1.5)	3"(80)	1 3	Capacitor Direct	8	0.5	26	132	42(92) 38(84)	31	412	250	595 547
	AF-33P	3(2.2)	3"(80)	3	Direct	10	0.6	33	160	42(97)	32	412	250	570
	50AFU4.4	0.5(0.4)	2"(50)	1 3	Capacitor Direct	3.5	0.23	12	61	29(64) 28(62)	50	346	204	516
4P	50AFU4.8	1(0.75)	2"(50)	1 3	Capacitor Direct	5	0.3	16	80	30(66) 29(64)	50	346	204	516
	80AFU41.5	2(1.5)	3"(80)	3	Direct	5	0.6	16	160	60(132)	76	500	256	622
	80AFU42.2	3(2.2)	3"(80)	3	Direct	7	0.6	23	160	71(156)	76	538	289	673
	80AFU43.7	5(3.7)	3"(80)	3	Direct	10.5	0.6	33	160	80(176)	76	538	289	697
	80AFP41.5	2(1.5)	3"(80)	3	Direct	8	0.5	26	132	54(119)	50	530	290	567
	80AFP42.2	3(2.2)	3"(80)	3	Direct	10	0.6	33	160	73(161)	50	553	313	623
	80AFP43.7	5(3.7)	3"(80)	3	Direct	15	0.6	50	160	82(180)	50	553	313	643
	100AFP43.7	5(3.7)	4"(100)	3	Direct	11.5	1.0	37	265	84(185)	50	570	313	643



AF-35A

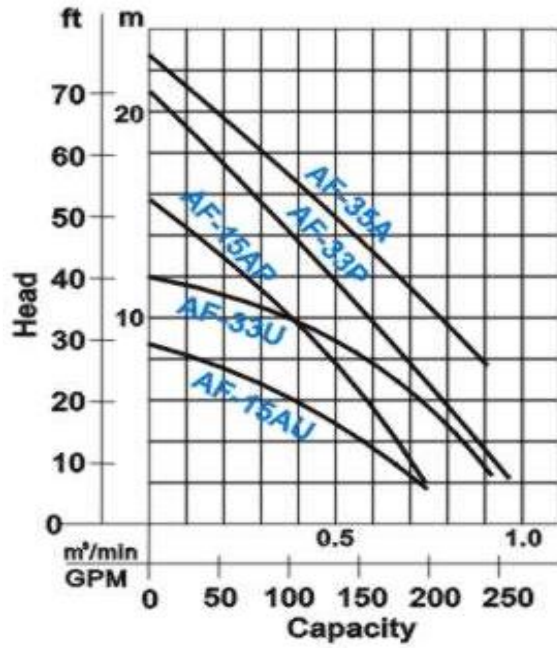

3. Jung Pumpen – UFK 35/2.AW.Y3

Dimensions with pump base (mm)

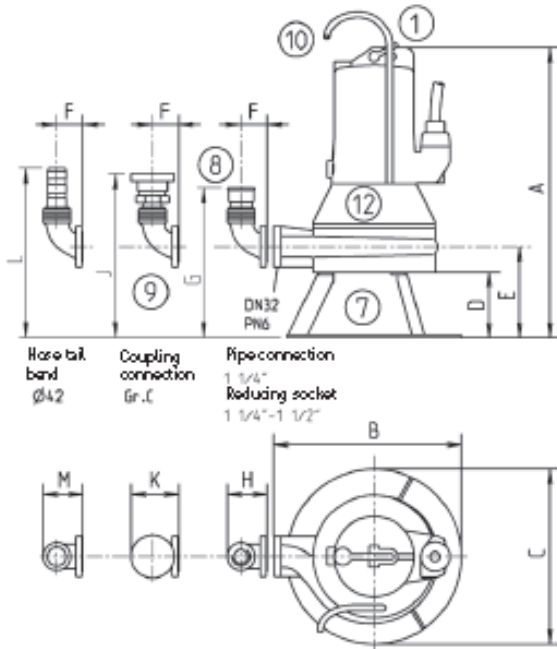

Typ	A	B	C	D	E	F	G	H	J	K	L	M
20/2M	440	290	230	100	140	60	230	90	310	110	320	90
25/2ME	520	330	250	140	180	60	270	90	350	110	360	90
35/2M+36/2M	520	330	250	140	180	60	270	90	350	110	360	90
45/2M	520	330	255	140	180	60	270	90	350	110	360	90
75/2M+76/2M	665	430	400	150	210	60	300	90	380	110	-	-

22625-08

PERFORMANCE

Type	Delivery head H [m]	6	9	12	15	18	21	25	28	32	34	36	38	40	44	46	48	50	52	54
20/2 M plus	Flow rate Q [m³/h]	18	17	16	13	10	6													
25/2 ME		17	16	15	12	9	5													
35/2 M							16	13	10	5										
36/2 M							16	14	10	7	5	2								
45/2 M													10	8	2					
75/2 M																				
76/2 M											17	16	15	13	8	5	2			
																13	11	9	6	3

4. Muffin Monster – Macerators (Model No. 30005 -0032)

Head drop, H = 445mm

Flow rate, Q = 477 m³/hr

Dimensions (mm)

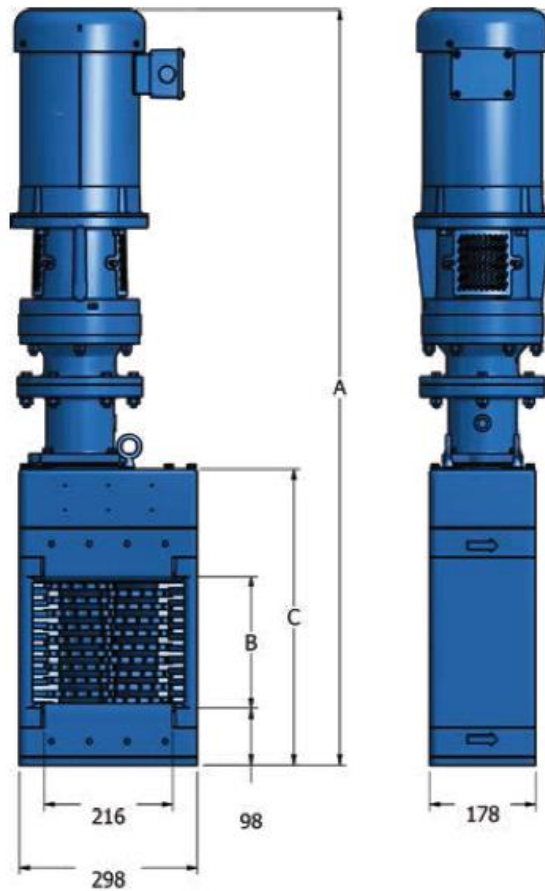

Open channel model	Flow rate ¹ - m ³ /hr	Head drop - mm	Standard dimensions ² - mm				Approximate net weight - kg
			A (IP55)	A (IP68)	B	C	
30005-0012	141	290	1307	1411	305	600	186
30005-0018	223	405	1486	1560	457	749	211
30005-0024	311	405	1602	1706	609	895	236
30005-0032	477	445	1799	1903	813	1092	263
30005-0040	686	495	2002	2106	1016	1295	295
30005-0060	1277	760	2474	2720	1524	1813	383

1. Flow based on optimum channel conditions. Consult factory for analysis of application.
2. Drive dimensions are a maximum based on a unit with a 4.0 kW motor.

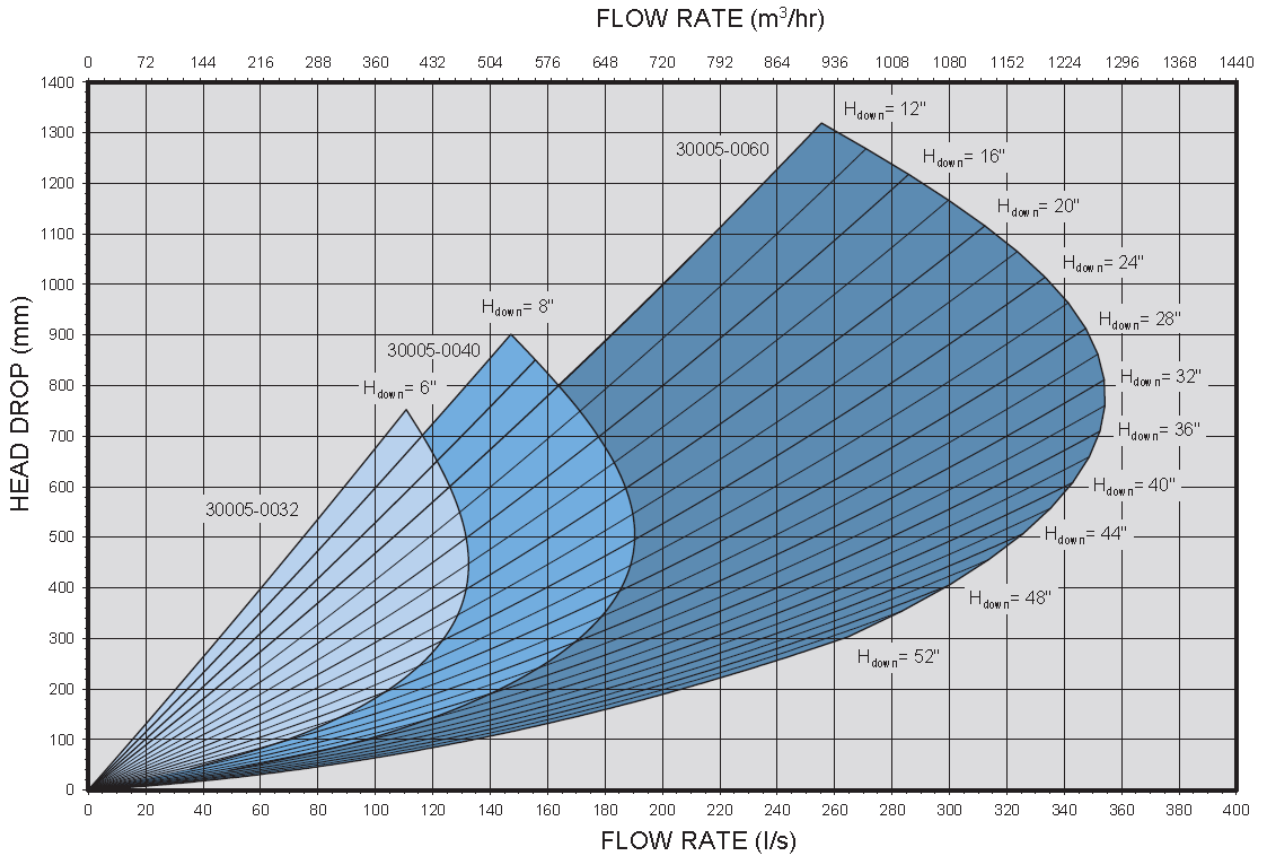

Documentation to be submitted upon project completion includes:

- Guarantees and warranties
- Certificate of Compliance (COC)
- Operating and maintenance manuals
- Updated professional electrical drawings

PART C4: SITE INFORMATION

Document reference	Title	No of pages
C4	This cover page Site Information	1
	Total number of pages	

Core clause 11.2(16) states

“Site Information is information which describes the Site and its surroundings and is in the documents which the Contract Data states it is in.”

In Contract Data, reference has been made to this Part 4 of the contract for the location of Site Information.

Description of the Site and its surroundings

General description

King Shaka International Airport,
King Shaka Drive
La Mercy
4407

Existing buildings, structures, and plant & machinery on the Site

Terminal Building
WWTP
Permit Office Building

Hidden services

Existing Electrical installations