

PROVINCE OF THE NORTHERN CAPE

WILLIAM HUMPHREYS ART GALLERY



**PROCUREMENT DOCUMENTS
FOR**

**WILLIAM HUMPHREYS ART GALLERY
UPGRADE OF HVAC SYSTEM**

CLIENTS REPRESENTATIVE

Mr. T. Semosa

William Humphreys Art Gallery
1 Cullinan Crescent
CIVIC CENTRE
KIMBERLEY, 8300

Email: tumelo@whag.co.za
Tel: 053 831 1724/5

PROJECT MANAGER

MVD Kalahari Consulting Engineers and Town
Planners

186 Du Toitspan Road
KIMBERLEY
8301

Email: theo@mvdkalahari.co.za
Tel: 053 831 1889

MECHANICAL ENGINEER

BVI Consulting Engineers

PO Box 1155
Upington
8801

Tel: 054 – 337 6600
Email: ricardoh@BVINC.co.za

BID NR: WB 01/2024
ADVERTISING DATE: 05 APRIL 2024
CLOSING DATE: 30 April 2024
CLOSING TIME: 11:00

BIDDER'S NAME :



REFERENCED INDEX TO PARTS OTHER THAN BILLS OF QUANTITIES

The following index has been included for ease of paginating the document.

FORM OF OFFER AND ACCEPTANCE	3
PART T1: TENDERING PROCEDURES.....	10
T1.1- Notice and Invitation to Tender.....	11
PART A	12
INVITATION TO BID	12
PART B	13
Notice and invitation to Tender	15
Tender will be evaluated according to the price and specific goals:.....	16
T 1.2 - Tender Data.....	18
T1.2- TENDER DATA	19
PART T2: RETURNABLE DOCUMENTS.....	29
T2.1- List of Returnable Documents	30
Resolution of Board of Directors	32
T2.2-1	32
Resolution of Board of Directors to Enter into Consortia or Joint Ventures.....	34
Special Resolution of Consortia or Joint Ventures.....	37
T2. 2-3.....	37
Schedule of Proposed Subcontractor	41
T2. 2-4	41
Capacity of Tenderer.....	43
T2. 2-5.....	43
Preference Certificate	49
T2. 2-6.....	49
80/20 or 90/10	51
80/20 or 90/10	51
Site Inspection Meeting Certificate	55
T2. 2-7	55
Declaration of Interest.....	57
T2. 2-8.....	57
Record of Addenda to Tender Documents	63
T2. 2-11	63
Particulars of Electrical Contractor.....	65
T2. 2-12.....	65
SPECIAL CONDITIONS OF TENDER	68
Compulsory Enterprise Questionnaire	69
T2. 2-9.....	69
PART C1 : CONTRACT DATA	73
Contract Data: JBCC 2000 Principal Building Agreement.....	74
Fixed Construction Guarantee – JBCC.....	89
Variable Construction Guarantee – JBCC	92
C2.2- Bills of Quantities.....	98
PART C3: SCOPE OF WORKS.....	99
Scope of Works – JBCC	100



Health and Safety Specification 104
PART C4: SITE INFORMATION..... 113
Site Information – JBCC..... 114
DRAWINGS..... 116



FORM OF OFFER AND ACCEPTANCE



FORM OF OFFER AND ACCEPTANCE

OFFER

The Employer, identified in the acceptance signature block, has solicited offers to enter into a contract for the procurement of:

WILLIAM HUMPHREYS ART GALLERY - UPGRADE OF HVAC SYSTEM

The Tenderer, identified in the offer signature block, has examined the documents listed in the tender data and addenda thereto as listed in the returnable schedules, and by submitting this offer has accepted the conditions of tender.

By the representative of the Tenderer, deemed to be duly authorized, signing this part of this form of offer and acceptance, the Tenderer offers to perform all of the obligations and liabilities of the Contractor under the contract including compliance with all its terms and conditions according to their true intent and meaning for an amount to be determined in accordance with the conditions of contract identified in the contract data.

THE OFFERED TOTAL OF THE PRICES INCLUSIVE OF VALUE ADDED TAX IS:

Rand (in words):	
Rand in figures:	R

VAT IS TO BE INCLUDED EVEN IF THE TENDERER IS A NON-VAT VENDOR

This offer may be accepted by the Employer by signing the acceptance part of this form of offer and acceptance and returning one copy of this document to the Tenderer before the end of the period of validity stated in the tender data, whereupon the Tenderer becomes the party named as the Contractor in the conditions of contract identified in the contract data.

THIS OFFER IS MADE BY THE FOLLOWING LEGAL ENTITY: (cross out block which is not applicable)

Company or Close Corporation: And: Whose Registration Number is: And: Whose Income Tax Reference Number is:	OR	Natural Person or Partnership: Whose Identity Number(s) is/are: Whose Income Tax Reference Number is/are:
---	-----------	--

AND WHO IS (if applicable):

Trading under the name and style of:
--

AND WHO IS:

Represented herein, and who is duly authorised to do so, by: Mr/Mrs/Ms: In his/her capacity as:	Note: A Resolution / Power of Attorney, signed by all the Directors / Members / Partners of the Legal Entity must accompany this Offer, authorising the Representative to make this offer.
---	---

SIGNED FOR THE TENDERER:

Name of representative	Signature	Date

WITNESSED BY:

Name of witness	Signature	Date



This Offer is in respect of: (Please indicate with an “X” in the appropriate block)

- The official documents
 The official alternative
 Own alternative (only if documentation makes provision therefore) ..

(N.B.: Separate Offer and Acceptance forms are to be completed for the main and for each alternative offer)

SECURITY OFFERED:

(a) the Tenderer accepts that in respect of contracts from R 500 000 and up to R 1 million, a surety of 2% of the contact value (excluding VAT) will be applicable and will be deducted by the Employer in terms of the applicable conditions of contract

(b) in respect of contracts above R 500 000, the Tenderer offers to provide security as indicated below:

(1) cash deposit of 10 % of the Contract Sum (excluding VAT) Yes No

(2) variable construction guarantee of 10 % of the Contract Sum (excluding VAT) **(DPW 10.3)** Yes No

(3) payment reduction of 10% of the value certified in the **payment certificate** (excluding VAT) Yes No

(4) cash deposit of 5% of the **contract sum** (excluding. VAT) and a payment reduction of 5% of the value certified in the **payment certificate** (excluding. VAT) Yes No

(5) fixed **construction guarantee** of 5% of the **contract sum** (excluding VAT) and a payment reduction of 5% of the value certified in the **payment certificate** (excluding VAT) Yes No

NB. Guarantees submitted must be issued by either an insurance company duly registered in terms of the Short-Term Insurance Act, 1998 (Act 35 of 1998) or by a bank duly registered in terms of the Banks Act, 1990 (Act 94 of 1990) on the pro-forma referred to above. No alterations or amendments of the wording of the pro-forma will be accepted.

The Tenderer elects as its *domicilium citandi et executandi* in the Republic of South Africa, where any and all legal notices may be served, as (physical address):

.....

Other Contact Details of the Tenderer are:

Telephone No	Cellular Phone No.
Fax No	Other contact No.
Postal address:	
Main or Principal Place of Business: E-mail Address :	
Registered Place of Business:	



.....
Banker Branch.....
Registration No of Tenderer at Department of Labour
CIDB Registration Number: (Attached copy of certificate)
CSD Number:.....SARS Pin.....



ACCEPTANCE

By signing this part of this form of offer and acceptance, the Employer identified below accepts the Tenderer’s offer. In consideration thereof, the Employer shall pay the Contractor the amount due in accordance with the conditions of contract identified in the contract data. Acceptance of the Tenderer’s offer shall form an agreement between the Employer and the Tenderer upon the terms and conditions contained in this agreement and in the contract that is the subject of this agreement.

The terms of the contract, are contained in:

- Part 1 Agreement and contract data, (which includes this agreement)
- Part 2 Pricing data
- Part 3 Scope of work
- Part 4 Site information

and drawings and documents or parts thereof, which may be incorporated by reference into Parts 1 to 4 above.

Deviations from and amendments to the documents listed in the tender data and any addenda thereto as listed in the tender schedules as well as any changes to the terms of the offer agreed by the Tenderer and the Employer during this process of offer and acceptance, are contained in the schedule of deviations attached to and forming part of this agreement. No amendments to or deviations from said documents are valid unless contained in this schedule.

The Tenderer shall within one week after receiving a completed copy of this agreement, including the schedule of deviations (if any), contact the Employer's agent (whose details are given in the contract data) to arrange the delivery of any bonds, guarantees, proof of insurance and any other documentation to be provided in terms of the conditions of contract identified in the contract data. Failure to fulfil any of these obligations in accordance with those terms shall constitute a repudiation of this agreement.

Notwithstanding anything contained herein, this agreement comes into effect, if delivered by hand on the day of delivery, or if delivered by courier within two working days after submission by the Employer to the courier services for a door-to-door delivery to the Tenderer, provided that the Employer notifies the Tenderer of the tracking number within 24 hours of such submission, or if delivered by telefax, one working day after transmission, or if delivered by email, one working day after transmission.

For the Employer:

Name of signatory	Signature	Date

Name of Organisation:	WILLIAM HUMPHREYS ART GALLERY
Address of Organisation:	William Humphreys Art Gallery 1 Cullinan Crescent CIVIC CENTRE KIMBERLEY, 8300

WITNESSED BY:

Name of witness	Signature	Date



Schedule of Deviations

1.1.1. Subject:
Detail:
1.1.2. Subject:
Detail:
1.1.3. Subject:
Detail:
1.1.4. Subject:
Detail:
1.1.5. Subject:
Detail:
1.1.6. Subject:
Detail:

By the duly authorized representatives signing this agreement, the Employer and the Tenderer agree to and accept the foregoing schedule of deviations as the only deviations from and amendments to the documents listed in the tender data and addenda thereto as listed in the tender schedules, as well as any confirmation, clarification or changes to the terms of the offer agreed by the Tenderer and the Employer during this process of offer and acceptance.

It is expressly agreed that no other matter whether in writing, oral communication or implied during the period between the issue of the tender documents and the receipt by the Tenderer of a completed signed copy of this Agreement shall have any meaning or effect in the contract between the parties arising from this agreement.



THE TENDER



PART T1: TENDERING PROCEDURES



T1.1- Notice and Invitation to Tender



PART A

INVITATION TO BID

SBD 1

YOU ARE HEREBY INVITED TO BID FOR REQUIREMENTS OF THE (NAME OF DEPARTMENT/PUBLIC ENTITY)

BID NUMBER:	WB 01/2024	CLOSING DATE:	30 April 2024	CLOSING TIME:	11:00
-------------	------------	---------------	---------------	---------------	-------

DESCRIPTION	WILLIAM HUMPHREYS ART GALLERY - UPGRADE OF HVAC SYSTEM
-------------	---

THE SUCCESSFUL BIDDER WILL BE REQUIRED TO FILL IN AND SIGN A WRITTEN CONTRACT FORM (SBD7).

BID RESPONSE DOCUMENTS MAY BE DEPOSITED
 IN THE BID BOX SITUATED AT (STREET ADDRESS)

William Humphreys Art Gallery
 1 Cullinan Crescent
 CIVIC CENTRE
 KIMBERLEY, 8300

SUPPLIER INFORMATION

NAME OF BIDDER			
POSTAL ADDRESS			
STREET ADDRESS			
TELEPHONE NUMBER	CODE	NUMBER	
CELLPHONE NUMBER			
FACSIMILE NUMBER	CODE	NUMBER	
E-MAIL ADDRESS			
VAT REGISTRATION NUMBER			

	TCS PIN:	OR	CSD No:
B-BBEE STATUS LEVEL VERIFICATION CERTIFICATE [TICK APPLICABLE BOX]	<input type="checkbox"/> Yes <input type="checkbox"/> No	B-BBEE STATUS LEVEL SWORN AFFIDAVIT	<input type="checkbox"/> Yes <input type="checkbox"/> No

IF YES, WHO WAS THE CERTIFICATE ISSUED BY?

AN ACCOUNTING OFFICER AS CONTEMPLATED IN THE CLOSE CORPORATION ACT (CCA) AND NAME THE APPLICABLE IN THE TICK BOX	<input type="checkbox"/>	AN ACCOUNTING OFFICER AS CONTEMPLATED IN THE CLOSE CORPORATION ACT (CCA)
	<input type="checkbox"/>	A VERIFICATION AGENCY ACCREDITED BY THE SOUTH AFRICAN ACCREDITATION SYSTEM (SANAS)
	<input type="checkbox"/>	A REGISTERED AUDITOR
	NAME:	

[A B-BBEE STATUS LEVEL VERIFICATION CERTIFICATE/SWORN AFFIDAVIT(FOR EMEs& QSEs) MUST BE SUBMITTED IN ORDER TO QUALIFY FOR PREFERENCE POINTS FOR B-BBEE]

ARE YOU THE ACCREDITED REPRESENTATIVE IN SOUTH AFRICA FOR THE GOODS /SERVICES /WORKS OFFERED?	<input type="checkbox"/> Yes <input type="checkbox"/> NO [IF YES ENCLOSE PROOF]	ARE YOU A FOREIGN BASED SUPPLIER FOR THE GOODS/SERVICES /WORKS OFFERED?	<input type="checkbox"/> Yes <input type="checkbox"/> No [IF YES ANSWER PART B:3 BELOW]
---	--	---	---

SIGNATURE OF BIDDER	DATE	
---------------------	--------------	------	--

CAPACITY UNDER WHICH THIS BID IS SIGNED (Attach proof of authority to sign this bid; e.g. resolution of directors, etc.)



TOTAL NUMBER OF ITEMS OFFERED		TOTAL BID PRICE (ALL INCLUSIVE)	
BIDDING PROCEDURE ENQUIRIES MAY BE DIRECTED TO:		TECHNICAL INFORMATION MAY BE DIRECTED TO:	
DEPARTMENT/ PUBLIC ENTITY		CONTACT PERSON	
CONTACT PERSON		TELEPHONE NUMBER	
TELEPHONE NUMBER		FACSIMILE NUMBER	
FACSIMILE NUMBER		E-MAIL ADDRESS	
E-MAIL ADDRESS			

**PART B
 TERMS AND CONDITIONS FOR BIDDING**

1. BID SUBMISSION:
<p>1.1. BIDS MUST BE DELIVERED BY THE STIPULATED TIME TO THE CORRECT ADDRESS. LATE BIDS WILL NOT BE ACCEPTED FOR CONSIDERATION.</p> <p>1.2. ALL BIDS MUST BE SUBMITTED ON THE OFFICIAL FORMS PROVIDED–(NOT TO BE RE-TYPED) OR ONLINE</p> <p>1.3. BIDDERS MUST REGISTER ON THE CENTRAL SUPPLIER DATABASE (CSD) TO UPLOAD MANDATORY INFORMATION NAMELY: (BUSINESS REGISTRATION/ DIRECTORSHIP/ MEMBERSHIP/IDENTITY NUMBERS; TAX COMPLIANCE STATUS; AND BANKING INFORMATION FOR VERIFICATION PURPOSES). B-BBEE CERTIFICATE OR SWORN AFFIDAVIT FOR B-BBEE MUST BE SUBMITTED TO BIDDING INSTITUTION.</p> <p>1.4. WHERE A BIDDER IS NOT REGISTERED ON THE CSD, MANDATORY INFORMATION NAMELY: (BUSINESS REGISTRATION/ DIRECTORSHIP/ MEMBERSHIP/IDENTITY NUMBERS; TAX COMPLIANCE STATUS MAY NOT BE SUBMITTED WITH THE BID DOCUMENTATION. B-BBEE CERTIFICATE OR SWORN AFFIDAVIT FOR B-BBEE MUST BE SUBMITTED TO BIDDING INSTITUTION.</p> <p>1.5. THIS BID IS SUBJECT TO THE PREFERENTIAL PROCUREMENT POLICY FRAMEWORK ACT 2000 AND THE PREFERENTIAL PROCUREMENT REGULATIONS, 2017, THE GENERAL CONDITIONS OF CONTRACT (GCC) AND, IF APPLICABLE, ANY OTHER LEGISLATION OR SPECIAL CONDITIONS OF CONTRACT.</p>
2. TAX COMPLIANCE REQUIREMENTS
<p>2.1 BIDDERS MUST ENSURE COMPLIANCE WITH THEIR TAX OBLIGATIONS.</p> <p>2.2 BIDDERS ARE REQUIRED TO SUBMIT THEIR UNIQUE PERSONAL IDENTIFICATION NUMBER (PIN) ISSUED BY SARS TO ENABLE THE ORGAN OF STATE TO VIEW THE TAXPAYER’S PROFILE AND TAX STATUS.</p> <p>2.3 APPLICATION FOR TAX COMPLIANCE STATUS (TCS) OR PIN MAY ALSO BE MADE VIA E-FILING. IN ORDER TO USE THIS PROVISION, TAXPAYERS WILL NEED TO REGISTER WITH SARS AS E-FILERS THROUGH THE WEBSITE WWW.SARS.GOV.ZA.</p> <p>2.4 BIDDERS MAY ALSO SUBMIT A PRINTED TCS TOGETHER WITH THE BID.</p> <p>2.5 IN BIDS WHERE CONSORTIA / JOINT VENTURES / SUB-CONTRACTORS ARE INVOLVED, EACH PARTY MUST SUBMIT A SEPARATE PROOF OF TCS / PIN / CSD NUMBER.</p> <p>2.6 WHERE NO TCS IS AVAILABLE BUT THE BIDDER IS REGISTERED ON THE CENTRAL SUPPLIER DATABASE (CSD), A CSD NUMBER MUST BE PROVIDED.</p>
3. QUESTIONNAIRE TO BIDDING FOREIGN SUPPLIERS



- 3.1. IS THE BIDDER A RESIDENT OF THE REPUBLIC OF SOUTH AFRICA (RSA)? YES NO
- 3.2. DOES THE BIDDER HAVE A BRANCH IN THE RSA? YES NO
- 3.3. DOES THE BIDDER HAVE A PERMANENT ESTABLISHMENT IN THE RSA? YES NO
- 3.4. DOES THE BIDDER HAVE ANY SOURCE OF INCOME IN THE RSA? YES NO

IF THE ANSWER IS “NO” TO ALL OF THE ABOVE, THEN, IT IS NOT A REQUIREMENT TO OBTAIN A TAX COMPLIANCE STATUS / TAX COMPLIANCE SYSTEM PIN CODE FROM THE SOUTH AFRICAN REVENUE SERVICE (SARS) AND IF NOT REGISTER AS PER 2.3 ABOVE.

NB: FAILURE TO PROVIDE ANY OF THE ABOVE PARTICULARS MAY RENDER THE BID INVALID.



Notice and invitation to Tender

WILLIAM HUMPHREYS ART GALLERY INVITES TENDERS FOR:

Project Title:	WILLIAM HUMPHREYS ART GALLERY - UPGRADE OF HVAC SYSTEM		
Bid No:	WB 01/2024	Closing Time:	11:00
Closing Date:	30 April 2024	Validity Period:	120 Days

Tenderers should have a CIDB contractor grading of	6 ME OR HIGHER
---	-----------------------

RESPONSIVENESS CRITERIA	
√	Only those tenderers who are registered with the CIDB, or are capable of being so prior to the evaluation of submission, in a contractor grading designation equal to or higher than a contractor grading designation determined in accordance with the sum tendered for the specified CLASS and RANGE of construction works are eligible to submit tenders.
√	Joint ventures are eligible to submit tender provided that: <ol style="list-style-type: none"> 1. every member of the joint venture is registered with the CIDB 2. The lead partner has a contractor grading designation one grade lower in the value or higher as indicated above; and 3. The combined contractor grading designation calculated in accordance with the Construction Industry Development Regulations is equal to or higher than a contractor grading designation determined in accordance with the sum tendered for this project. 4. A Joint Venture Agreement <u>must</u> be submitted with the tender in the case of a joint venture offer.
√	Tender offer must be properly received on the closing date and time specified on the invitation, fully completed and signed in ink (All as per Standard Conditions of Tender).
√	Submission of applicable: Resolution by the Legal Entity or Consortium / joint venture, authorising a dedicated person(s) to sign documents on behalf of the Firm / Consortium / joint venture.
√	Submission of (PA-11) DECLARATION OF INTEREST.
√	Submission of other compulsory returnable schedules / documents as per LIST OF RETURNABLE DOCUMENTS.
√	Submission of SITE INSPECTION CERTIFICATE as proof for attendance of compulsory site meeting.
√	Submission of PRICED BILL OF QUANTITIES WITH THE TENDER
√	No bidder or any of its consortium/joint venture members may have an interest in any of the other bidder/joint venture/consortium participation in this bid." Bidders may be disqualified should such be found in your bid submission.



Tender will be evaluated according to the price and specific goals:

<p>The 80/20 system for requirements with a Rand value of up to R50 000 000; OR</p> <p>The 90/10 system for requirements with a Rand value above R50 000 000.</p> <p>Where the financial value inclusive of VAT of one or more responsive tenders received equals or is less than R 50 000 000, the 80/20 system shall be applicable.</p> <p>Where the financial value inclusive of VAT of all responsive tenders received has a value in excess of R 50 000 000, the 90/10 system shall be applicable.</p>

Price / Preference / Functionality:				
Requirement	≤ R50 000 000	> R50 000 000		
Price	80	90	Total must equal	100
Preference	20	10		
Functionality	0 of 80	0 of 90		

Table1: Specific goals for the tender and points claimed are indicated per table below.
(Note to organ of state: Where either the 90/10 or 80/10 goals point system is applicable, corresponding points must be indicated as such. (Refer to Item 4, Page 48 for Scoring)
Notes to tenderers: The tenderer must indicate how they claim points for each preference system.)

CRITERION	POINTS	PROOF OF CLAIM
B-BBEE Status	4	PA-40 , Valid B-BBEE verification certificate or an affidavit confirming micro enterprise status.
Business Based in the Northern Cape	4	PA-40 , Proof of Business Address not older than three months.
Ownership by Youth	4	PA-40 , Company Registration Documents, and Identity Documents of Shareholders.
Ownership by Women	4	PA-40 , Company Registration Documents, and Identity Documents of Shareholders.
Ownership by People with Disabilities	4	PA-40 , Company Registration Documents, and Identity Documents of Shareholders.

Collection of tender documents:

DEPOSIT	The document is available at www.etenders.gov.za and www.whag.co.za as the Gallery does not print out the document nor sell the document is payable and is required on collection of the tender documents.
INSPECTION	Compulsory Clarification Meeting – 15 April 2024 at 11H00 at William Humpherys Art Gallery premises

Enquiries related to tender documents may be addressed to:

Dept Project Leader:	Mr. T. Semosa	Telephone no:	053 831 1724/5
Cell no:	N/A	Fax no:	N/A
E-mail:	tumelo@whag.co.za		



Deposit / RETURN of tender documents:

DEPOSITED IN	ATTENTION: Mr. T. Semosa OR Tender documents may be placed in the tender box outside the main entrance: William Humphreys Art Gallery 1 Cullinan Crescent CIVIC CENTRE KIMBERLEY, 8300
Telegraphic, telephonic, telex, facsimile, electronic and / or late tenders will not be accepted.	
Requirements for sealing, addressing, delivery, opening and assessment of tenders are stated in the TENDER DATA (T 1. 2)	



T 1.2 - Tender Data



T1.2- TENDER DATA

The department of roads & public Works invites tender FOR:

Project Title:	WILLIAM HUMPHREYS ART GALLERY - UPGRADE OF HVAC SYSTEM		
Bid No:	WB 01/2024	Closing Time:	11:00
Closing Date:	30 April 2024	Validity Period:	120 days

CLAUSE NUMBER	DETAIL
	<p>The conditions of tender are the Standard Conditions of Tender as contained in Annexure F of the CIDB Standard for Uniformity in Construction Procurement as per Government Notice No 423 Published in Government Gazette No. 42662 of 22 August 2019 and as amended for time to time. (see. www.cidb.org.za)</p> <p>The Standard Conditions of Tender make several references to the Tender Data for details that apply specifically to this tender. The Tender Data shall have precedence in the interpretation of any ambiguity or inconsistency between it and the Standard Conditions of Tender.</p> <p>Each item of data given below is cross-referenced to the clause marked 'F' in the above-mentioned Standard Conditions of Tender.</p>
F.1.1	<p>The employer is the Government of the Republic of South Africa in its Northern Cape Provincial Government, represented by the Accounting Officer of the William Humphreys Art Gallery.</p>
F.1.2	<p>For this contract the single volume approach is adopted.</p> <p>This procurement document has been formatted and compiled under the headings for a single volume approach as contained in table 6 of the CIDB's "Standard Uniformity in Construction Procurement."</p> <p>The list of Returnable Documents identifies which of the documents a tenderer must complete when submitting a tender offer. The tenderer must submit his tender offer by completing the Returnable Documents including the Fully Priced Activity Schedule/ Bills of Quantities, signing the "Offer" section in the Form of Offer and Acceptance" and delivering the single volume procurement document back to the Department bounded up as it was when it was received.</p> <p>The single volume procurement document issued by the employer comprises the following:</p> <p>TENDER</p> <p>Part 1: Tendering Procedures T1.1 – Tender notice and invitation to tender (Refer to index) T1.2 – Tender data (Refer to index)</p> <p>Part 2: Returnable Documents T2.1 – List of returnable documents (Refer to index) T2.2 - Returnable Schedules</p> <p>CONTRACT</p> <p>Part 1: Agreement and Contract Data C1.1 – Form of offer and acceptance (Refer to index) C1.2 – Contract data (Refer to index) C1.3 – Form of Guarantee (Refer to index)</p> <p>Part 2: Pricing Data C2.1 – Pricing instructions (Refer to index) C2.2 - Activity schedules / Bills of Quantities</p> <p>Part 3: Scope of Work C3 – Scope of work (Refer to index)</p> <p>Part 4: Site Information C4 – Site information (Refer to index)</p>



F.1.4	The employer's agent is:	
	Name	Mr. T. van den Berg
	Capacity	PROJECT MANAGER
	Address	186 Du Toitspan Road KIMBERLEY, 8301
	Tel:	053 839 2100
	Fax	N/A
	E-mail	theo@mvdkalahari.co.za
F.1.5.2	Insert the following: "..... tender offers, <u>save for all tenders being nonresponsive</u> , re-issue a tender covering	
F.2.1	For eligibility refer to Notice and Invitation to Tender T1.1.	
	A contract will only be entered into with a tenderer who has in his employment management and supervisory staff satisfying the requirement of the scope of works for labour intensive competencies for supervisory and management staff.	

	<p>Only those tenderers who are registered with the CIDB or are capable of being so prior to the evaluation of Submissions in a GENERAL BUILDING class of construction, in the grading mentioned in the Notice and Invitation to Tender (T1.1), are eligible to submit tenders.</p> <p>Tender offers scoring less than a minimum of 70% in respect of the total evaluation points for quality will be regarded as non-responsive.</p> <p>NOTE: THIS SPECIAL CONDITIONS OF TENDER IS REGARDED AS A REPONSIVNESS CRITERIA, THUS FAILURE TO COMPLETE AND COMPLY WILL LEAD TO THE DISQUALIFICATION OF YOUR TENDER</p> <p><u>Individuals must be identified for each of the key personnel listed below.</u></p> <p>In order to be considered for an appointment in terms of this tender, the tenderer must have the Following key personnel who will be the single point of accountability and responsibility for the management of the construction works in its employment at the close of tender. Alternatively, a signed undertaking from an organisation having the required personnel, stating that they will undertake the necessary work on behalf of the tenderer in terms of a sub-consultant agreement, will be acceptable.</p> <p>A: Management Capability 1: Table A clause F.2.1 Contractors to provide CVs with qualifications and Organogram on Senior Staff indicating experience within construction of similar projects. (Directors, Site Managers/Foremen, Qualified Artisans and Technical Staff)</p> <p>B: Management Capability 2: Table B clause F.2.1 Contractor's current and previous work as reflected on form WHAG-01 for projects of similar scope for Central Package Unit Systems.</p> <p>C: Financial Stability: Provide Bank Rating from Banking Institute to justify credit risk (Letter of financial good standing indicating bank rating from banking institution)</p> <p>D: Technical Approach: Contractors to provide Preliminary Construction Program and Approach Methodology for execution of project within the construction period of 12.</p>
--	--

Bank Rating

In order to be eligible for award in terms of this tender, tenderers must submit a bank rating from a recognized financial institution (not older than 3 months at tender closing date) which indicates that the bidder possesses the minimum following bank code;

- Bank rating of minimum Code C: Good for amount quoted if strictly in the way of business – Unlikely to commit themselves beyond their means

Financial Statements

In order to be eligible for award in terms of this tender, tenderers must submit signed audited statements of the last three years.

Bidders must take note of the following;

The amount of enquiry on the bank rating letter must be equal to the sum of the amount tendered (including VAT) or higher.

A tender shall not be evaluated further under the following conditions;

1.A bidder who fails to provide a bank rating letter.

- Bidders who fail to satisfy any of the above eligibility criteria contained in clause C.2.1 shall be deemed to be non-responsive and their bids shall not be considered further. Bidders shall not be provided a second opportunity by the employer to submit any information in relation to any of the above eligibility criteria where such information is not provided by the bidder, bound within the bid submission, on the date and time of the bid closing.

Replace Clarification with Compulsory Briefing.

For particulars regarding a pre-tender site inspection meeting, see Tender Notice and Invitation to Tender T1.1

If a tenderer wishes to submit an alternative tender offer, the only criteria permitted for such alternative tender offer is that it demonstrably satisfies the Employer's standards and requirements, the details of which may be obtained from the Employer's Agent.

Calculations, drawings and all other pertinent technical information and characteristics as well as modified or proposed Pricing Data must be submitted with the alternative tender offer to enable the Employer to evaluate the efficacy of the alternative and its principal elements, to take a view on the degree to which the alternative complies with the Employer's standards and requirements and to evaluate the acceptability of the pricing proposals. Calculations must be set out in a clear and logical sequence and must clearly reflect all design assumptions. Pricing Data must reflect all assumptions in the development of the pricing proposal. Acceptance of an alternative tender offer will mean acceptance in principle of the offer. It will be an obligation of the contract for the tenderer, in the event that the alternative is accepted, to accept full responsibility and liability that the alternative offer complies in all respects with the Employer's standards and requirements.

The modified Pricing Data must include an amount equal to 5% of the amount tendered for the alternative offer to cover the Employer's costs of confirming the acceptability of the detailed design before it is constructed.

Alternative tender offer permitted: Yes No

Replace sub-clause F.2.1 with the following;

Return all returnable documents to the employer after completing them in their entirety by writing in non-erasable black ink

Parts of each tender offer communicated on paper shall be submitted as an original, plus 1 (one) copy.

The tender shall be signed by a person duly authorized to do so. Tenders submitted by joint ventures of two or more firms shall be accompanied by the document of formation of the joint venture, in the form of a joint venture agreement, in which it is defined precisely the conditions under which the joint venture will function, its period of duration, the persons authorized to represent and obligate it, the participation of the several firms forming the joint venture, and any other information necessary to permit a full appraisal of its functioning. Failure to provide the joint venture agreement, bound with the tender submission, on the date and time of the closing of the bid, shall render the tender non-responsive.

The tender offer validity period is 120 days.

A tender may be rejected as non-responsive if the tenderer fails to provide any clarification requested by the employer within the time for submission stated in the employer's written request for such clarification. The clarification of a tender offer includes the provision of the priced bills of quantities (Part C2.2: Bills of Quantities).

The tenderer shall, when requested by the Employer to do so, submit the names of all management and supervisory staff that will be employed to supervise the Labour-Intensive portion of the works together with satisfactory evidence that such staff members satisfy the eligibility requirements.



Access shall be provided for inspections, tests and analysis as may be required by the Employer

Letter of Good Standing

Tender are required to submit, bound with the tender submission, a letter of good from the compensation commissioner indicating that the bidder is in good standing. Failure to submit will result in the bid not being evaluated further.

Notwithstanding any requests for confirmation of receipt of Addenda issued, the tenderer shall be deemed to have received such addenda if the employer can show proof of transmission thereof (or a notice in respect thereof) via electronic mail, facsimile or registered post.

Bidders will be considered non-responsive if, inter alia:

1. The bidder has failed to attend the compulsory briefing meeting and failed to submit a fully completed briefing session certificate; After the briefing session, a signed briefing certificate will be issued to all the bidders who attended the briefing session.
2. The bid is submitted by Telegraphic, telephonic, telex, facsimile (faxed) or email media or if the tender is submitted late.
3. The bidder does not comply with the eligibility criteria listed in F2.1 above;
4. The resolution for signatory is not attached to the tender submission on a company letterhead.
5. The bidder has failed to fully complete and sign SBD1, SBD4, SBD8 & SBD9.
6. The bidder failed to comply to TAX obligations at the award of the bid.



Stage 1 Functionality

Functionality of responsive bids submitted will be evaluated according to the predetermined criteria described below.

A bid will not be evaluated further if it fails to meet the minimum threshold of total 70 points out of maximum 100 points for functionality as prescribed in the following tables.

	FUNCTIONALITY CRITERIA	POINTS ALLOCATED
A	Management Capability 1	25
B	Management Capability 2	25
C	Financial Stability	25
D	Technical Approach	25
E	TOTAL	100

A							
Functionality criteria 1:						Weighting factor	
Management Capability 1:						25	
Contractors to provide CVs with qualifications and Organogram on Senior Staff indicating experience within construction of similar projects. (Directors, Site Managers/Foremen, Qualified Artisans and Technical Staff)							
NB: CONTRACTOR TO TICK RELEVANT EXPERIENCE PER MANAGEMENT STAFF AREA							
Sub-Criteria	YEARS EXPERIANCE POINTS SCORING PER SUB-CRITERIA						
Management Staff	15 years up (5=25 Points)	11 to 14 years (4=20 Points)	6 to 10 years (3=15 Points)	3 to 5 years (2=10 Points)	0 to 2 years (1=5 Point)		
Director							
Site Manager							
Foreman							
Qualified Artisans							
Technical Staff							
EXAMPLE							
Sub-Criteria	YEARS EXPERIANCE POINTS SCORING PER SUB-CRITERIA						
Management Staff	15 years up (25 Points)	11 to 10 years (20 Points)	6 to 10 years (15 Points)	3 to 5 years (10 Points)	0 to 2 years (5 Point)		
Director			√				
Site Manager	√						
Foreman		√					
Qualified Artisans				√			
Technical Staff		√					



B		
Functionality criteria 2:		Weighting factor
Management Capability 2: Contractor's current and previous work as reflected on form WHAG-01 for projects of similar scope for Central Package Unit Systems. Contractors to provide References (Letters), Appointment Letters and Practical Completion Certificates for previous and current projects undertaken and completed successfully (With Time, Cost & Quality)		25
7 and above	5 = 25 Points	
5 to 6 Projects	4 = 20 Points	
3 to 4 Projects	3 = 15 Points	
1 to 2 Projects	2 = 5 Points	
0 Projects	1 = 0 Points	
C		
Functionality criteria 3:		Weighting factor
Financial Stability: Provide Bank Rating from Banking Institute to justify credit risk (Letter of financial good standing indicating bank rating from banking institution)		25
Sub Criteria		
Credit Rating of 'A':	5 = 25 points	
Credit Rating of 'B':	4 = 15 points	
Credit Rating of 'C':	3 = 10 points	
Credit Rating of 'D':	2 = 5 points	
Credit Rating of 'E':	1 = 2 point	
No Credit Rating records furnished:	= 0 points	
D		
Functionality criteria 4:		Weighting factor
Technical Approach		25
Contractors to provide Preliminary Construction Program and Approach Methodology for execution of project within the construction period of 12 Months.		
Excellent	5 = 25 points	
Good	4 = 20 points	
Above Average	3 = 15 points	
Average	2 = 10 points	
Poor	1 = 0 point	
Total Criteria Weighting		100%



	<p>Stage 2 Price and Specific Goals</p> <p><i>Add the following:</i> The financial offer will be scored using the following Formula:</p> $P_s = 90 \left[1 - \frac{P_t - P_{min}}{P_{min}} \right]$ <p>where</p> <p>P_s = Points scored for price of tender under consideration; P_t = Price of tender under consideration; and</p> <p>P_{min} = Price of lowest acceptable tender.</p> <p>A trust, consortium or joint venture will qualify for points for their B-BBEE status level as a legal entity, provided that the entity submits their BBB-EE status level certificate. A trust, consortium or joint venture will qualify for points for their B-BBEE status level as an unincorporated entity, provided that the entity submits their consolidated B-BBEE scorecard as if they were a group.</p> <p>Bidders to fail to satisfy any of the above Functionality Criteria in clause F.2.1 shall be determined to be non-responsive and their bids shall not be considered further. Bidders shall not be provided a second opportunity by the employer to submit any information in relation to any of the above eligibility criteria where such information is not provided by the bidder, bound within the bid submission, on the date of the bidding.</p>
<p>F .2.7</p>	<p>For particulars regarding A PRE-TENDER SITE INSPECTION MEETING, see Notice and Invitation to Tender T1.1</p>
<p>F .2.12</p>	<p>If a tenderer wishes to submit an own alternative offer, the only criteria permitted for such alternative tender offer is that if demonstrably satisfies the Employer’s standards and requirements. A tender may submit alternative tender offers only if a main tender offer, strictly in accordance with all the requirements of the tender documents, is also submitted. Provided that the tenderer’s main tender offer is according to specification and would under normal circumstances be recommended for acceptance, his alternative tender offer may also be considered for the purpose of the award of the contract.</p> <p>Calculations, drawings and all other pertinent technical information and characteristics as well as modified or proposed Pricing Data must be submitted with the alternative tender offer to enable the Employer to evaluate the efficacy of the alternative and its principal elements, to take view on the degree to which the alternative complies with the Employer’s standards and requirements and to evaluate the acceptability of the pricing proposals. Calculations must be set out in a clear and logical sequence and must clearly reflect all design assumptions. Pricing Data must reflect all assumptions in the development of the pricing proposal</p> <p>Acceptance of an alternative tender offer will mean acceptance in principle of the offer. It will be a contractual obligation of the tenderer, in the event that the alternative is accepted, to accept full responsibility and liability that the alternative offer complies in all respect with the Employer’s standards and requirements.</p> <p>The modification Pricing Data must include an amount equal to 5% of the amount tenderer for the alternative offer to cover the Employer’s cost of confirming the acceptability of the detailed design before it is constructed</p> <p>Alternative tender offer permitted: NO</p>
<p>F .2.12</p>	<p>The EMPLOYERS ADDRESS FOR DELIVERY of tender offers and identification details to be shown on each tender offer package are as per Notice and Invitation to Tender T1.1</p>
<p>F.2.13.6 F .3.5</p>	<p><u>A One-envelope procedure is required:</u> <u>Envelope 1: Form & Offer, Bid Documents, Bank Rating, Financial Statements and Functionality Criteria, etc, as clause F.2.1 above</u></p>



F.2.15	The CLOSING TIME for submission of tender offers is as per Notice and Invitation to Tender T1.1
F.2.16	The tender offer VALIDITY PERIOD is as per Notice and Invitation to Tender T1.1
F.2.18	The tenderer will be required to submit a fully Priced Bill / Lump Sum tender document, with tender closing.
F.2.19	Access shall be provided for inspection, tests and analysis as may be required by the Employer.
F.2.22	Not a requirement.
F.3.4.1 F.3.4.2.	The location for opening of the tender offers, immediately after closing time thereof shall be at: William Humphreys Art Gallery, I Cullinan Crescent Kimberley
F.3.11.1	<p>The procedure for the evaluation of responsive tender is</p> <ul style="list-style-type: none"> • Method 1: Financial offer • Method 2: Financial offer and preferences • Method 3: Financial offer and quality • Method 4: Financial offer, quality and preferences <p style="text-align: right;">METHOD 4 - WILL apply for this tender.</p>
F.3.11	<p>Scoring the Financial Offer:</p> <p>$P_s = NEP + W_c$ (calculated separately for each tender offer)</p> <p>The score for quality and financial offer is to be combined, before the addition of the score for preference, as follows:</p> $W_c = W_3 \left(1 + \frac{P - P_m}{P_m}\right)$ <p>where</p> <p>W_3 = The number of tender evaluation points for quality and financial offer and equals:</p> <ol style="list-style-type: none"> 1) 90 where the financial value inclusive of VAT of all responsive tenders received have a value in excess of R 50 000 000; or 2) 80 where the financial value inclusive of VAT of one or more responsive tender offers equals or is less than R 50 000 000. <p>P = The price of the financial offer of the submission under consideration.</p> <p>P_m = The price of the financial offer of the submission of the lowest acceptable tender.</p> <p>W_c = Points allocated for price of tender under consideration.</p> <p>Scoring for Preferences:</p> <p>In terms of the Preferential Procurement Regulations 2011 preferences points for B-BBEE level of contribution are calculated on their B-BBEE Status Level of Contribution in the industry.</p> <p>Tender evaluation points will be awarded to tenderers who completes the preferencing schedule and who is found to be eligible for the preference claimed.</p> <p>Points for Direct Preference will be calculated according to the B-BBEE Status Level of Contribution of the tender under consideration as a per the points stated in the Notice and Invitation to Tender T1.1 and claimed in this form.</p> <p>Calculate Total tender Evaluation Points:</p> <p>The point calculated for price will be added to the point scored for preference for each individual tender offer.</p>
F.3.13.1	<p>Tender offers will only be accepted if:</p> <ol style="list-style-type: none"> a) The tenderer or any of its directors is not listed on the Register of Tender Defaulters in terms of the Prevention and Combating of Corrupt Activities Act, 2004 (Act 12 of 2004) as a person prohibited from doing business with the public sector; and b) The tenderer has not: <ol style="list-style-type: none"> 1. abused the Employer's Supply Chain Management System; or 2. Failed to perform on any previous contract and has been given a written notice to this effect.



F.3.18	Provide to the successful tender one copy of the signed contract document.
F.4	ADDITIONAL CONDITIONS OF TENDER The additional conditions of the tender are:
F.4.1	Invalid Tender Tenders shall be considered invalid and shall be endorsed and recorded as such in the tender opening record, by the responsible official who opened the tender, in the following circumstances: a) If the tender offer is not submitted on the Form of Offer and Acceptance bound into this tender document (form C1.1, Part C1: Agreements and Contract Data): b) If the Form of Offer and Acceptance has not been completed or has not been signed by the authorised representative of the tender c) If the Form of Offer and Acceptance is signed, but the name of the tenderer is not stated or is indecipherable. d) If the tender offer is not completed in non-erasable ink.
F.4.2	Negotiations with preferred tenderers The Employer may negotiate the final terms of a contract with tenderers identified through a competitive tendering process as preferred tenderers provided that such negotiations: a) Does not allow any preferred tenderer a second or unfair opportunity. b) Is not to the detriment of any other tender; and c) Does not lead to a higher price than the tender as submitted. Minutes of any such negotiations shall be kept for record purposes
F.4.3	Letter of good standing (COIDA) The Tenderer shall submit to the Employer a letter of good standing (COIDA)
F.4.4	Claims arising after submissions of tender No claim for any extra arising out of any doubt or obscurity as to the true intent and meaning of anything contained in the Conditions of Contract, Scope of Work and Pricing Data, will be admitted by the Employer after submission of any tender and the tenderer shall be deemed to have: 1) Read and fully understood the whole text of the Contract Data, Scope of Work and Pricing Data and thoroughly acquainted himself with the nature of the works proposed and generally of all matters which may influence the Contract. 2) Visited the site of any proposed works. 3) Requested the Employer or his duly authorised agent to make clear the actual requirements of anything contained in the Scope of Works and Pricing Data, the extract meaning or interpretation of which is not clearly intelligible to the tenderer. 4) Received any Addenda to the tender documents which have been issued in accordance with the Employer's Supply Chain Management Policy.
F.4.5	Imbalance in tendered rates In the event of tendered rates or lump sums being declared by the Employer to be unacceptable to it because they are either excessively low or high or not in proper balanced with other rates or lump sums, the tenderer may be required to produce evidence and advance arguments in support of the tendered rates or lump sums objected to. If, after submission of such evidence and any further evidence requested, the Employer is still not satisfied with the tendered rates or lump sums objected to, it may request the tenderer to amend these rates and lump sums along the lines indicated by it. The tenderer will then have the option to alter and/or amend the rates and lump sums objected to and such other amounts as are agreed on by the Employer, but this shall be done without altering the tender offer as tendered. Should the Tenderer fail to amend his Tender in a manner acceptable to the Employer, the Employer may reject the Tender.
F.4.6	The Employer shall not formally issue tender documents in electronic format as contemplated in C.2.12.2 and C.2.13.3 and shall only issue tender documents in hardcopy. An electronic version of the issued tender documents may be made available to the tenderer, upon written request in terms of this clause, subject to the following: (a) Electronic copies of the contract document, or parts thereof, will only be provided to tenderers who have been issued with the tender documents as contemplated in C.1.2 in hardcopy. (b) The electronic version shall not be regarded as a substitute for the issued tender documents.



	<p>(c) The Employer shall not accept Tender submitted in electronic format. Tenderers may not complete and submit a printed copy of the electronic version of the tender document or part thereof. Only those Tender that have been completed on an issued hard copy tender document shall be considered.</p> <p>(d) The Employer accepts no responsibility or liability arising from the reliance on or use of the electronic version provided in terms of this clause. The Employer further does not guarantee that the electronic version corresponds with the issued tender document in all respects. Tenderers are alerted to the fact that electronic version of the tender documents may not reflect any notices or addenda that amend the tender document.</p> <p>(e) Any non-compliance with these provisions, including effecting any unauthorized alterations to the tender as contemplated in C2.11, shall render the tender invalid. The Employer reserves the right to take any action against such tenderer allowed in law including, in circumstances where the tender had already been awarded, the right to cancel the contract.</p> <p>(f) In requesting the electronic version of the tender document or parts thereof, the tenderer is deemed to have read, understood and accepted all of the above conditions.</p>
<p>F.4.7</p>	<p>Local Content and Production for Designated Sectors: N/A</p> <p>Only locally produced or locally manufactured steel products and components for the construction with stipulated minimum threshold of 0% for local production and content will be considered. If the quantities of steel products and components for construction required cannot be wholly sourced in South Africa (RSA) based manufacturers and/or at the designated local content threshold of 0%, bidders and procuring entities should obtain written authorization from DTI should there be a need to import and copy of this authorization letter must be submitted together with the bid document at the closing date and time.</p> <p>The exchange rate to be used for the calculation of the local production and content must be the exchange rate published by the South Africa Reserve Bank (SARB) at 12:00 on the date of advertisement of the bid.</p> <p>A bid will be disqualified if:</p> <ul style="list-style-type: none"> • The bidder fails to achieve the stipulated minimum threshold for the local production and content unless written exemption has been granted to the bidder by the DTI to bid at a lower content level. • Failure to indicate the minimum percentage (0%) or not meeting minimum percentage for local content will automatically invalidate the bid from further consideration. • The Declaration Certificate for Local Content (SBD 6.2), the Annex C (Local Content Declaration: Summary Schedule) are not completed, duly signed, and submitted by the closing date and time of the bid <p>Bidders may contact the Metals Fabrication, Capital and Rail Transport Equipment Unit within the DTI at telephone 012 394 1356 or Primary Minerals Processing and Construction Unit at telephone 012 394 5157</p>
<p>F.4.8</p>	<p>Subcontracting as a condition of Tender: N/A</p> <p>The successful bidder shall be required to subcontract a minimum N/A of the value of the Contract including labour and materials to EME'S and/or QSE'S enterprises determined in terms of section 9(1) of the Broad-Based Black Economic Empowerment Act. These sub-contractors can be selected from the CIDB database who are registered on the CSD for the purposes of compliance. Bidders shall make allowance in their preliminaries for any additional costs required in this regard, for example, for the preparation of work packages, management of the subcontractors including site supervision, drafting and conclusion of the subcontract agreements, subcontractor OHS plan approvals, etc., that may arise due to this commitment.</p>
<p>F.4.9</p>	<p>Compliance with Occupation Health and Safety Act 1993</p> <p>Tenderers are to note the requirements of the Occupational Health and Safety Act (No. 85 of 1993) and the Construction Regulations 2014 issued in terms of Section 43 of the Act. The tenderer shall be deemed to have read and fully understood the requirements of the above Act and Regulations and to have allowed for all the costs in compliance therewith. Tenderers are to note that the service provider is required to ensure that all sub-contractor/sub-consultants or other engaged in the performance of this contract also comply with the above requirements.</p>



PART T2: RETURNABLE DOCUMENTS



T2.1- List of Returnable Documents



LIST OF RETURNABLE DOCUMENTS

1. RETURNABLE SCHEDULES REQUIRED FOR TENDER EVALUATION PURPOSES

(Insert a tick in the "Returnable document" column to indicate which documents must be returned with the tender)

Tender document name		Number of pages issued	Returnable document
T 2. 2-1	Resolution of Board of Directors (PA-15.1)	1 Page	<input checked="" type="checkbox"/> Yes
T2. 2-2	Resolution of Board of Directors to enter into consortia or JV's (PA-15.2)	2 Pages	<input checked="" type="checkbox"/> Yes
T2 2-3	Special Resolution of Consortia or JV's (PA-15.3)	3 Pages	<input checked="" type="checkbox"/> Yes
T2. 2-4	Schedule of proposed sub-contractors (WHAG-15: EC)	1 Page	<input checked="" type="checkbox"/> Yes
T2. 2-5	Capacity of Tender (PA-40: Declaration of designated groups for preferential procurement)	1 Page	<input checked="" type="checkbox"/> Yes
T2. 2-7	Site Inspection Meeting Certificate (WHAG-16: EC)	3 Pages	<input checked="" type="checkbox"/> Yes
T2. 2-8	Declaration of Interest (PA-11)	3 Pages	<input checked="" type="checkbox"/> Yes
T2. 2-9	Compulsory Enterprise Questionnaire	2 Pages	<input checked="" type="checkbox"/> Yes
F.2.1	Bank Rating Letter (not older than 3 months at the close of tender)	Pages	<input type="checkbox"/> No
F.2.1	Past three years Audited financial Statements	Pages	<input checked="" type="checkbox"/> Yes
	Valid Letter of Good Standing	Pages	<input checked="" type="checkbox"/> Yes
	Joint Venture Agreement (State percentage split)	Pages	<input checked="" type="checkbox"/> Yes
	Priced Bills of Quantities	Pages	<input checked="" type="checkbox"/> Yes

2. RETURNABLE SCHEDULES THAT WILL BE INCORPORATED INTO THE CONTRACT

Tender document name		Number of pages issued	Returnable document
T2. 2-6	Preference Certificate (SBD6.1)	6 Pages	<input checked="" type="checkbox"/> Yes
T2. 2-11	Record of Addenda to tender documents (WHAG-21: EC)	1 Pages	<input checked="" type="checkbox"/> Yes
T2. 2-12	Particulars of Contractor (refer to index)	1 Page	<input checked="" type="checkbox"/> Yes

3. OTHER DOCUMENTS THAT WILL BE INCORPORATED INTO THE CONTRACT

Tender document name		Number of pages issued	Returnable document
Form of construction guarantee (WHAG 10.1 & WHAG 10.3)		Pages	<input checked="" type="checkbox"/> Yes



Resolution of Board of Directors

T2.2-1



RESOLUTION OF BOARD OF DIRECTORS: (PA-15.1)

RESOLUTION of a meeting of the Board of *Directors / Members / Partners of:

(legally correct full name and registration number, if applicable, of the Enterprise)

Held at _____ (place)

On _____ (date)

RESOLVED that:

1. The Enterprise submits a Bid / Tender to the DEPARTMENT OF ROADS & PUBLIC WORKS in respect of the following project:

(Project description as per Bid / Tender Document)

Bid / Tender Number: _____ (Bid / Tender Number as per Bid / Tender Document)

2. *Mr/Mrs/Ms: _____

in *his/her Capacity as : _____ (Position in the Enterprise)

and who will sign as follows : _____

be, and is hereby, authorised to sign the Bid / Tender, and any and all other documents and/or correspondence in connection with and relating to the Bid / Tender, as well as to sign any Contract, and any and all documentation, resulting from the award of the Bid / Tender to the Enterprise mentioned above.

	NAME	Capacity	Signature
1			
2			
3			
4			
5			
6			

Note:

1. * Delete which is not applicable
2. **NB.** This resolution must be signed by all the Directors / Members / Partners of the Bidding Enterprise
3. Should the number of Directors / Members/Partners exceed the space available above, additional names and signatures must be supplied on a separate page

ENTERPRISE STAMP



Resolution of Board of Directors to Enter into Consortia or Joint Ventures

T2. 2-2



RESOLUTION OF BOARD OF DIRECTORS TO ENTER INTO CONSORTIA OR JOINT VENTURES: (PA-15.2)

RESOLUTION of a meeting of the Board of *Directors / Members / Partners of:

(Legally correct full name and registration number, if applicable, of the Enterprise)

Held at _____ (place)

On _____ (date)

RESOLVED that:

3. The Enterprise submits a Bid /Tender, in consortium/Joint Venture with the following Enterprises:

(List all the legally correct full names and registration numbers, if applicable, of the Enterprises forming the Consortium/Joint Venture)

to the DEPARTMENT OF ROADS & PUBLIC WORKS in respect of the following project:

(Project description as per Bid /Tender Document)

Bid / Tender Number: _____ (Bid / Tender Number as per Bid /Tender Document)

4. *Mr/Mrs/Ms: _____

in *his/her Capacity as: _____ (Position in the Enterprise)

and who will sign as follows: _____

be, and is hereby, authorised to sign a consortium/joint venture agreement with the parties listed under item 1 above, and any and all other documents and/or correspondence in connection with and relating to the consortium/joint venture, in respect of the project described under item 1 above.

5. The Enterprise accepts joint and several liability with the parties listed under item 1 above for the due fulfilment of the obligations of the joint venture deriving from, and in any way connected with, the Contract to be entered into with the Department in respect of the project described under item 1 above.

6. The Enterprise chooses as its *domicilium citandi et executandi* for all purposes arising from this joint venture agreement and the Contract with the Department in respect of the project under item 1 above:

Physical address: _____

_____ (code)



Postal Address: _____

 _____ (code)

Telephone number: _____ (code)

Fax number: _____ (code)

	Name	Capacity	Signature
1			
2			
3			
4			
5			
6			
7			
8			
9			
10			
11			
12			
13			
14			
15			

Note:

1. * Delete which is not applicable
2. **NB.** This resolution must be signed by all the Directors / Members / Partners of the Bidding Enterprise
3. Should the number of Directors / Members/Partners exceed the space available above, additional names and signatures must be supplied on a separate page

ENTERPRISE STAMP

Joint ventures are eligible to submit tender provided that:

- every member of the joint venture is registered with the CIDB
- The combined contractor grading designation calculated in accordance with the Construction Industry Development Regulations is equal to or higher than a contractor grading designation determined in accordance with the sum tendered for this project.
- A Joint Venture Agreement must be submitted with the tender in the case of a joint venture offer.



Special Resolution of Consortia or Joint Ventures

T2. 2-3



SPECIAL RESOLUTION OF CONSORTIA OR JOINT VENTURES: (PA-15.3)

RESOLUTION of a meeting of the duly authorized representatives of the following legal entities who have entered into a consortium/joint venture to jointly bid for the project mentioned below: *(legally correct full names and registration numbers, if applicable, of the Enterprises forming a Consortium/Joint Venture)*

- 7. _____

- 8. _____

- 9. _____

- 10. _____

- 11. _____

- 12. _____

- 13. _____

Held at _____ *(place)*

On _____ *(date)*

RESOLVED that:

RESOLVED that:

A. The above-mentioned Enterprises submit a Bid in Consortium/Joint Venture to the DEPARTMENT OF ROADS & PUBLIC WORKS in respect of the following project:

_____ *(Project description as per Bid /Tender Document)*

Bid / Tender Number: _____ *(Bid / Tender Number as per Bid /Tender Document)*

B. Mr/Mrs/Ms: _____

in *his/her Capacity as: _____ *(Position in the Enterprise)*

and who will sign as follows: _____



be, and is hereby, authorized to sign the Bid, and any and all other documents and/or correspondence in connection with and relating to the Bid, as well as to sign any Contract, and any and all documentation, resulting from the award of the Bid to the Enterprises in Consortium/Joint Venture mentioned above.

- C. The Enterprises constituting the Consortium/Joint Venture, notwithstanding its composition, shall conduct all business under the name and style of: _____
- D. The Enterprises to the Consortium/Joint Venture accept joint and several liability for the due fulfilment of the obligations of the Consortium/Joint Venture deriving from, and in any way connected with, the Contract entered into with the Department in respect of the project described under item A above.
- E. Any of the Enterprises to the Consortium/Joint Venture intending to terminate the consortium/joint venture agreement, for whatever reason, shall give the Department 30 days written notice of such intention. Notwithstanding such decision to terminate, the Enterprises shall remain jointly and severally liable to the Department for the due fulfilment of the obligations of the Consortium/Joint Venture as mentioned under item D above.
- F. No Enterprise to the Consortium/Joint Venture shall, without the prior written consent of the other Enterprises to the Consortium/Joint Venture and of the Department, cede any of its rights or assign any of its obligations under the consortium/joint venture agreement in relation to the Contract with the Department referred to herein.
- G. The Enterprises choose as the *domicilium citandi et executandi* of the Consortium/Joint Venture for all purposes arising from the consortium/joint venture agreement and the Contract with the Department in respect of the project under item A above:

Physical address: _____

_____ (code)

E-mail address : _____

Business address: _____

_____ (code)

Postal Address: _____

_____ (code)

Telephone number: _____ (code)

Fax number: _____ (code)



	Name	Capacity	Signature
1			
2			
3			
4			
5			
6			
7			
8			
9			
10			
11			
12			
13			
14			
15			

Note:

1. * Delete which is not applicable
2. **NB.** This resolution must be signed by all the Duly Authorised Representatives of the Legal Entities to the Consortium Joint Venture submitting this Bid
3. Should the number of Duly Authorised Representatives of the Legal Entities joining forces in this Bid exceed the space available above, additional names and signatures must be supplied on a separate page
4. Resolutions, duly completed and signed, from the separate Enterprises who participate in this Consortium/Joint Venture must be attached to the Special Resolution.

Joint ventures are eligible to submit tender provided that:

- every member of the joint venture is registered with the CIDB
- The combined contractor grading designation calculated in accordance with the Construction Industry Development Regulations is equal to or higher than a contractor grading designation determined in accordance with the sum tendered for this project.
- A Joint Venture Agreement must be submitted with the tender in the case of a joint venture offer.



Schedule of Proposed Subcontractor

T2. 2-4



SCHEDULE OF PROPOSED SUBCONTRACTORS: (WHAG-15: EC)

We notify you that it is our intention to employ the following Subcontractors for work in this contract.

We confirm that all subcontractors who are contracted to construct a house are registered as home builders with the National Home Builders Registration Council and/or with the CIDB (Construction Industry Development Board).

	Name and address of proposed Subcontractor	Nature and extent of work	Previous experience with Subcontractor
1			
2			
3			
4			
5			

Name of representative	Signature	Capacity	Date

Name of organisation:	
------------------------------	--



Capacity of Tenderer

T2. 2-5



WORK CAPACITY OF TENDERER:

4. **WORK CAPACITY:** *(The Tenderer is requested to furnish the following particulars, attach additional pages if more space is required. Failure to furnish the particulars may result in the Tender being disregarded.)*

Skilled artisans employed		Unskilled employees employed	
Categories of artisans	Number	Categories of employees	Number

4.1. Provide full particulars of:

Machinery	Plant	Workshops



5. PARTICULARS OF COMMITMENTS WHICH THE TENDERER HAS PREVIOUSLY COMPLETED AND PRESENTLY ENGAGED WITH:

5.1. Current projects:

FORM: WHAG-01

Project	Place (town)	Reference / Contact person	Contact Tel. No.	Contract amount	Contract period	Date of commencement	Scheduled date of completion
1							
2							
3							
4							
5							
6							
7							
8							
9							
10							
11							



5.2. Previous projects:

FORM: WHAG-01

Project	Place (town)	Reference / Contact person	Contact Tel. No.	Contract amount	Contract period	Date of commencement	Scheduled date of completion	Actual date of completion
1								
2								
3								
4								
5								
6								
7								
8								
9								
10								

Name of Tenderer	Signature	Date



PA- 40: DECLARATION OF DESIGNATED GROUPS FOR PREFERENTIAL PROCUREMENT

Name of Tenderer

EME1 QSE2 Non EME/QSE (tick applicable box)

1. LIST ALL PROPRIETORS, MEMBERS OR SHAREHOLDERS BY NAME, IDENTITY NUMBER, CITIZENSHIP AND DESIGNATED GROUPS.

Name and Surname #	Identity/ Passport number and Citizenship##	Percentage owned	Black	Indicate if youth	Indicate if woman	Indicate if person with disability	Indicate if living in rural / underdeveloped area/township	Indicate if military veteran
1.		%	<input type="checkbox"/> Yes <input type="checkbox"/> No	<input type="checkbox"/> Yes <input type="checkbox"/> No	<input type="checkbox"/> Yes <input type="checkbox"/> No	<input type="checkbox"/> Yes <input type="checkbox"/> No	<input type="checkbox"/> Yes <input type="checkbox"/> No	<input type="checkbox"/> Yes <input type="checkbox"/> No
2.		%	<input type="checkbox"/> Yes <input type="checkbox"/> No	<input type="checkbox"/> Yes <input type="checkbox"/> No	<input type="checkbox"/> Yes <input type="checkbox"/> No	<input type="checkbox"/> Yes <input type="checkbox"/> No	<input type="checkbox"/> Yes <input type="checkbox"/> No	<input type="checkbox"/> Yes <input type="checkbox"/> No
3.		%	<input type="checkbox"/> Yes <input type="checkbox"/> No	<input type="checkbox"/> Yes <input type="checkbox"/> No	<input type="checkbox"/> Yes <input type="checkbox"/> No	<input type="checkbox"/> Yes <input type="checkbox"/> No	<input type="checkbox"/> Yes <input type="checkbox"/> No	<input type="checkbox"/> Yes <input type="checkbox"/> No
4.		%	<input type="checkbox"/> Yes <input type="checkbox"/> No	<input type="checkbox"/> Yes <input type="checkbox"/> No	<input type="checkbox"/> Yes <input type="checkbox"/> No	<input type="checkbox"/> Yes <input type="checkbox"/> No	<input type="checkbox"/> Yes <input type="checkbox"/> No	<input type="checkbox"/> Yes <input type="checkbox"/> No
5.		%	<input type="checkbox"/> Yes <input type="checkbox"/> No	<input type="checkbox"/> Yes <input type="checkbox"/> No	<input type="checkbox"/> Yes <input type="checkbox"/> No	<input type="checkbox"/> Yes <input type="checkbox"/> No	<input type="checkbox"/> Yes <input type="checkbox"/> No	<input type="checkbox"/> Yes <input type="checkbox"/> No
6.		%	<input type="checkbox"/> Yes <input type="checkbox"/> No	<input type="checkbox"/> Yes <input type="checkbox"/> No	<input type="checkbox"/> Yes <input type="checkbox"/> No	<input type="checkbox"/> Yes <input type="checkbox"/> No	<input type="checkbox"/> Yes <input type="checkbox"/> No	<input type="checkbox"/> Yes <input type="checkbox"/> No
7.		%	<input type="checkbox"/> Yes <input type="checkbox"/> No	<input type="checkbox"/> Yes <input type="checkbox"/> No	<input type="checkbox"/> Yes <input type="checkbox"/> No	<input type="checkbox"/> Yes <input type="checkbox"/> No	<input type="checkbox"/> Yes <input type="checkbox"/> No	<input type="checkbox"/> Yes <input type="checkbox"/> No
8.		%	<input type="checkbox"/> Yes <input type="checkbox"/> No	<input type="checkbox"/> Yes <input type="checkbox"/> No	<input type="checkbox"/> Yes <input type="checkbox"/> No	<input type="checkbox"/> Yes <input type="checkbox"/> No	<input type="checkbox"/> Yes <input type="checkbox"/> No	<input type="checkbox"/> Yes <input type="checkbox"/> No
9.		%	<input type="checkbox"/> Yes <input type="checkbox"/> No	<input type="checkbox"/> Yes <input type="checkbox"/> No	<input type="checkbox"/> Yes <input type="checkbox"/> No	<input type="checkbox"/> Yes <input type="checkbox"/> No	<input type="checkbox"/> Yes <input type="checkbox"/> No	<input type="checkbox"/> Yes <input type="checkbox"/> No
10.		%	<input type="checkbox"/> Yes <input type="checkbox"/> No	<input type="checkbox"/> Yes <input type="checkbox"/> No	<input type="checkbox"/> Yes <input type="checkbox"/> No	<input type="checkbox"/> Yes <input type="checkbox"/> No	<input type="checkbox"/> Yes <input type="checkbox"/> No	<input type="checkbox"/> Yes <input type="checkbox"/> No

Where Owners are themselves a Company, Close Corporation, Partnership etc, identify the ownership of the Holding Company, together with Registration number
 ## State date of South African citizenship obtained (not applicable to persons born in South Africa)

1 EME: Exempted Micro Enterprise
 2 QSE: Qualifying Small Business Enterprise



2. DECLARATION:

The undersigned, who warrants that he/she is duly authorized to do so on behalf of the Tenderer, hereby confirms that:

1. The information and particulars contained in this Affidavit are true and correct in all respects.
2. The Broad-based Black Economic Empowerment Act, 2003 (Act 53 of 2003), Preferential Procurement Policy Framework Act, 2000 (Act 5 of 2000), the Preferential Procurement Regulations, 2020 as amended, National Small Business Act 102 of 1996 as amended and all documents pertaining to this Tender were studied and understood and that the above form was completed according to the definitions and information contained in said documents.
3. The Tenderer understands that any intentional misrepresentation or fraudulent information provided herein shall disqualify the Tenderer’s offer herein, as well as any other tender offer(s) of the Tenderer simultaneously being evaluated or will entitle the Employer to cancel any Contract resulting from the Tenderer’s offer herein.
4. The Tenderer accepts that the Employer may exercise any other remedy it may have in law and in the Contract, including a claim for damages for having to accept a less favourable tender as a result of any such disqualification due to misrepresentation or fraudulent information provided herein.
5. Any further documentary proof required by the Employer regarding the information provided herein, will be submitted to the Employer within the time period as may be set by the latter.

Signed by the Tenderer

Name of representative	Signature	Date



Preference Certificate

T2. 2-6



PREFERENCE POINTS CLAIM FORM IN TERMS OF THE PREFERENTIAL PROCUREMENT REGULATIONS 2022

This preference form must form part of all tenders invited. It contains general information and serves as a claim form for preference points for specific goals.

NB: BEFORE COMPLETING THIS FORM, TENDERERS MUST STUDY THE GENERAL CONDITIONS, DEFINITIONS AND DIRECTIVES APPLICABLE IN RESPECT OF THE TENDER AND PREFERENTIAL PROCUREMENT REGULATIONS, 2022

1. GENERAL CONDITIONS

1.1 The following preference point systems are applicable to invitations to tender:

- the 80/20 system for requirements with a Rand value of up to R50 000 000 (all applicable taxes included); and
- the 90/10 system for requirements with a Rand value above R50 000 000 (all applicable taxes included).

1.2 To be completed by the organ of state

(delete whichever is not applicable for this tender).

- a) The applicable preference point system for this tender is the 90/10 preference point system.
- b) Either the 90/10 or 80/20 preference point system will be applicable in this tender. The lowest/highest acceptable tender will be used to determine the accurate system once tenders are received.

1.3 Points for this tender (even in the case of a tender for income-generating contracts) shall be awarded for:

- (a) Price; and
- (b) Specific Goals.

1.4 To be completed by the organ of state:

The maximum points for this tender are allocated as follows:

	POINTS
PRICE	80
SPECIFIC GOALS	20
Total points for Price and SPECIFIC GOALS	100

1.5 Failure on the part of a tenderer to submit proof or documentation required in terms of this tender to claim points for specific goals with the tender, will be interpreted to mean that preference points for specific goals are not claimed.

1.6 The organ of state reserves the right to require of a tenderer, either before a tender is adjudicated or at any time subsequently, to substantiate any claim in regard to preferences, in any manner required by the organ of state.



2. DEFINITIONS

- (a) **“tender”** means a written offer in the form determined by an organ of state in response to an invitation to provide goods or services through price quotations, competitive tendering process or any other method envisaged in legislation;
- (b) **“price”** means an amount of money tendered for goods or services, and includes all applicable taxes less all unconditional discounts;
- (c) **“rand value”** means the total estimated value of a contract in Rand, calculated at the time of bid invitation, and includes all applicable taxes;
- (d) **“tender for income-generating contracts”** means a written offer in the form determined by an organ of state in response to an invitation for the origination of income-generating contracts through any method envisaged in legislation that will result in a legal agreement between the organ of state and a third party that produces revenue for the organ of state, and includes, but is not limited to, leasing and disposal of assets and concession contracts, excluding direct sales and disposal of assets through public auctions; and
- (e) **“the Act”** means the Preferential Procurement Policy Framework Act, 2000 (Act No. 5 of 2000).

3. FORMULAE FOR PROCUREMENT OF GOODS AND SERVICES

3.1. POINTS AWARDED FOR PRICE

3.1.1 THE 80/20 OR 90/10 PREFERENCE POINT SYSTEMS

A maximum of 80 or 90 points is allocated for price on the following basis:

$$Ps = 80 \left(1 - \frac{Pt - P_{min}}{P_{min}} \right) \text{ or } Ps = 90 \left(1 - \frac{Pt - P_{min}}{P_{min}} \right)$$

Where

- Ps = Points scored for price of tender under consideration
- Pt = Price of tender under consideration
- Pmin = Price of lowest acceptable tender

3.2. FORMULAE FOR DISPOSAL OR LEASING OF STATE ASSETS AND INCOME GENERATING PROCUREMENT

3.2.1. POINTS AWARDED FOR PRICE

A maximum of 80 or 90 points is allocated for price on the following basis:

$$Ps = 80 \left(1 + \frac{Pt - P_{max}}{P_{max}} \right) \text{ or } Ps = 90 \left(1 + \frac{Pt - P_{max}}{P_{max}} \right)$$

Where

- Ps = Points scored for price of tender under consideration
- Pt = Price of tender under consideration
- Pmax = Price of highest acceptable tender



4. POINTS AWARDED FOR SPECIFIC GOALS

- 4.1. In terms of Regulation 4(2); 5(2); 6(2) and 7(2) of the Preferential Procurement Regulations, preference points must be awarded for specific goals stated in the tender. For the purposes of this tender the tenderer will be allocated points based on the goals stated in table 1 below as may be supported by proof/ documentation stated in the conditions of this tender:
- 4.2. In cases where organs of state intend to use Regulation 3(2) of the Regulations, which states that, if it is unclear whether the 80/20 or 90/10 preference point system applies, an organ of state must, in the tender documents, stipulate in the case of—
- (a) an invitation for tender for income-generating contracts, that either the 80/20 or 90/10 preference point system will apply and that the highest acceptable tender will be used to determine the applicable preference point system; or
 - (b) any other invitation for tender, that either the 80/20 or 90/10 preference point system will apply and that the lowest acceptable tender will be used to determine the applicable preference point system,
- then the organ of state must indicate the points allocated for specific goals for both the 90/10 and 80/20 preference point system.

Table 1: Specific goals for the tender and points claimed are indicated per the table below.

(Note to organs of state: Where either the 90/10 or 80/20 preference point system is applicable, corresponding points must also be indicated as such.

Note to tenderers: The tenderer must indicate how they claim points for each preference point system.)

4.2.1. Preferential Points will be awarded as per below scoring:

CRITERION	POINTS	PROOF OF CLAIM
B-BBEE Status	4	Valid B-BBEE verification certificate or an affidavit confirming micro enterprise status.
Business Location		Proof of Business Address not older than three months.
Northern Cape	4	
Other Provinces	0	
Ownership by Youth	4	PA-40 , Company Registration Documents, and Identity Documents of Shareholders.
Ownership by Women	4	PA-40 , Company Registration Documents, and Identity Documents of Shareholders.
Ownership by People with Disabilities	4	PA-40 , Company Registration Documents, and Identity Documents of Shareholders.

4.2.1.1. B-BBEE Status Points will be awarded as indicated below:

B-BBEE STATUS	POINTS	Number of points claimed (80/20 system) (To be completed by the tenderer)
Level 1	4	
Level 2	3	
Level 3	2	
Level 4 and below	1	
Non-compliant	0	

4.2.1.2. Business Locality Points will be awarded as indicated below:

Locality Point Scoring (Northern Cape = Preference)	POINTS	Number of points claimed (80/20 system) (To be completed by the tenderer)
Northern Cape	4	
Other Provinces	0	

4.2.1.3. Ownership Points for Women will be awarded as indicated below:

OWNERSHIP	POINTS	Number of points claimed (80/20 system) (To be completed by the tenderer)
50% and above	4	
40% and above	3	
25% and above	2	
10% and above	1	
Below 10%	0	

4.2.1.4. Ownership Points for Youth will be awarded as indicated below:

OWNERSHIP	POINTS	Number of points claimed (80/20 system) (To be completed by the tenderer)
50% and above	4	
40% and above	3	
25% and above	2	
10% and above	1	
Below 10%	0	

4.2.1.5. Ownership Points for People with Disabilities will be awarded as indicated below:

OWNERSHIP	POINTS	Number of points claimed (80/20 system) (To be completed by the tenderer)
50% and above	4	
40% and above	3	
25% and above	2	
10% and above	1	
Below 10%	0	



DECLARATION WITH REGARD TO COMPANY/FIRM

4.3. Name of company/firm.....

4.4. Company registration number:

4.5. TYPE OF COMPANY/ FIRM

- Partnership/Joint Venture / Consortium
- One-person business/sole propriety
- Close corporation
- Public Company
- Personal Liability Company
- (Pty) Limited
- Non-Profit Company
- State Owned Company

[TICK APPLICABLE BOX]

4.6. I, the undersigned, who is duly authorised to do so on behalf of the company/firm, certify that the points claimed, based on the specific goals as advised in the tender, qualifies the company/ firm for the preference(s) shown and I acknowledge that:

- i) The information furnished is true and correct;
- ii) The preference points claimed are in accordance with the General Conditions as indicated in paragraph 1 of this form;
- iii) In the event of a contract being awarded as a result of points claimed as shown in paragraphs 1.4 and 4.2, the contractor may be required to furnish documentary proof to the satisfaction of the organ of state that the claims are correct;
- iv) If the specific goals have been claimed or obtained on a fraudulent basis or any of the conditions of contract have not been fulfilled, the organ of state may, in addition to any other remedy it may have –
 - (a) disqualify the person from the tendering process;
 - (b) recover costs, losses or damages it has incurred or suffered as a result of that person's conduct;
 - (c) cancel the contract and claim any damages which it has suffered as a result of having to make less favourable arrangements due to such cancellation;
 - (d) recommend that the tenderer or contractor, its shareholders and directors, or only the shareholders and directors who acted on a fraudulent basis, be restricted from obtaining business from any organ of state for a period not exceeding 10 years, after the *audi alteram partem* (hear the other side) rule has been applied; and
 - (e) forward the matter for criminal prosecution, if deemed necessary.

..... SIGNATURE(S) OF TENDERER(S)	
SURNAME AND NAME:
DATE:
ADDRESS:



Site Inspection Meeting Certificate

T2. 2-7



SITE INSPECTION MEETING CERTIFICATE: WHAG-16-EC

Project title:	WILLIAM HUMPHREYS ART GALLERY - UPGRADE OF HVAC SYSTEM
-----------------------	--

This is to certify that I, _____ representing
 _____ in the company of
 _____ visited the site on:

I have made myself familiar with all local conditions likely to influence the work and the cost thereof. I further certify that I am satisfied with the description of the work and explanations given at the site inspection meeting and that I understand perfectly the work to be done, as specified and implied, in the execution of this contract.

Name of Tenderer	Signature	Date

Name of Project Leader	Signature	Date

Name of Project Manager	Signature	Date



Declaration of Interest

T2. 2-8



SBD 4

BIDDER’S DISCLOSURE

1. PURPOSE OF THE FORM

Any person (natural or juristic) may make an offer or offers in terms of this invitation to bid. In line with the principles of transparency, accountability, impartiality, and ethics as enshrined in the Constitution of the Republic of South Africa and further expressed in various pieces of legislation, it is required for the bidder to make this declaration in respect of the details required hereunder.

Where a person/s are listed in the Register for Tender Defaulters and / or the List of Restricted Suppliers, that person will automatically be disqualified from the bid process.

2. Bidder’s declaration

2.1 Is the bidder, or any of its directors / trustees / shareholders / members / partners or any person having a controlling interest³ in the enterprise, employed by the state? **YES/NO**

2.1.1 If so, furnish particulars of the names, individual identity numbers, and, if applicable, state employee numbers of sole proprietor/ directors / trustees / shareholders / members/ partners or any person having a controlling interest in the enterprise, in table below.

Full Name	Identity Number	Name of State institution

2.2 Do you, or any person connected with the bidder, have a relationship with any person who is employed by the procuring institution? **YES/NO**

2.2.1 If so, furnish particulars:

2.3 Does the bidder or any of its directors / trustees / shareholders / members / partners or any person having a controlling interest in the enterprise have any interest in any other related enterprise whether or not they are bidding for this contract? **YES/NO**

2.3.1 If so, furnish particulars:

³ the power, by one person or a group of persons holding the majority of the equity of an enterprise, alternatively, the person/s having the deciding vote or power to influence or to direct the course and decisions of the enterprise.



3 DECLARATION

I, the undersigned, (name)..... in submitting the accompanying bid, do hereby make the following statements that I certify to be true and complete in every respect:

- 3.1 I have read and I understand the contents of this disclosure;
- 3.2 I understand that the accompanying bid will be disqualified if this disclosure is found not to be true and complete in every respect;
- 3.3 The bidder has arrived at the accompanying bid independently from, and without consultation, communication, agreement or arrangement with any competitor. However, communication between partners in a joint venture or consortium⁴ will not be construed as collusive bidding.
- 3.4 In addition, there have been no consultations, communications, agreements or arrangements with any competitor regarding the quality, quantity, specifications, prices, including methods, factors or formulas used to calculate prices, market allocation, the intention or decision to submit or not to submit the bid, bidding with the intention not to win the bid and conditions or delivery particulars of the products or services to which this bid invitation relates.
- 3.4 The terms of the accompanying bid have not been, and will not be, disclosed by the bidder, directly or indirectly, to any competitor, prior to the date and time of the official bid opening or of the awarding of the contract.
- 3.5 There have been no consultations, communications, agreements or arrangements made by the bidder with any official of the procuring institution in relation to this procurement process prior to and during the bidding process except to provide clarification on the bid submitted where so required by the institution; and the bidder was not involved in the drafting of the specifications or terms of reference for this bid.
- 3.6 I am aware that, in addition and without prejudice to any other remedy provided to combat any restrictive practices related to bids and contracts, bids that are suspicious will be reported to the Competition Commission for investigation and possible imposition of administrative penalties in terms of section 59 of the Competition Act No 89 of 1998 and or may be reported to the National Prosecuting Authority (NPA) for criminal investigation and or may be restricted from conducting business with the public sector for a period not exceeding ten (10) years in terms of the Prevention and Combating of Corrupt Activities Act No 12 of 2004 or any other applicable legislation.

I CERTIFY THAT THE INFORMATION FURNISHED IN PARAGRAPHS 1, 2 and 3 ABOVE IS CORRECT.

I ACCEPT THAT THE STATE MAY REJECT THE BID OR ACT AGAINST ME IN TERMS OF PARAGRAPH 6 OF PFMA SCM INSTRUCTION 03 OF 2021/22 ON PREVENTING AND COMBATING ABUSE IN THE SUPPLY CHAIN MANAGEMENT SYSTEM SHOULD THIS DECLARATION PROVE TO BE FALSE.

.....
Signature

.....
Date

.....
Position

.....
Name of Bidder

² Joint venture or Consortium means an association of persons for the purpose of combining their expertise, property, capital, efforts, skill and knowledge in an activity for the execution of a contract.



DECLARATION OF BIDDER’S PAST SUPPLY CHAIN MANAGEMENT PRACTICES

- 1 This Standard Bidding Document must form part of all bids invited.
- 2 It serves as a declaration to be used by institutions in ensuring that when goods and services are being procured, all reasonable steps are taken to combat the abuse of the supply chain management system.
- 3 The bid of any bidder may be disregarded if that bidder, or any of its directors have-
 - a. abused the institution’s supply chain management system;
 - b. committed fraud or any other improper conduct in relation to such system; or c. failed to perform on any previous contract.
- 4 **In order to give effect to the above, the following questionnaire must be completed and submitted with the bid.**

Item	Question	Yes	No
4.1	Is the bidder or any of its directors listed on the National Treasury’s Database of Restricted Suppliers as companies or persons prohibited from doing business with the public sector? (Companies or persons who are listed on this Database were informed in writing of this restriction by the Accounting Officer/Authority of the institution that imposed the restriction after the <i>audi alteram partem</i> rule was applied). The Database of Restricted Suppliers now resides on the National Treasury’s website(www.treasury.gov.za) and can be accessed by clicking on its link at	Yes <input type="checkbox"/>	No <input type="checkbox"/>
4.1.1	If so, furnish particulars:		
4.2	Is the bidder or any of its directors listed on the Register for Tender Defaulters in terms of section 29 of the Prevention and Combating of Corrupt Activities Act (No 12 of 2004)? The Register for Tender Defaulters can be accessed on the National Treasury’s website (www.treasury.gov.za) by clicking on its link at the bottom of the home page.	Yes <input type="checkbox"/>	No <input type="checkbox"/>
4.2.1	If so, furnish particulars:		
4.3	Was the bidder or any of its directors convicted by a court of law (including a court outside of the Republic of South Africa) for fraud or corruption during the past five years?	Yes <input type="checkbox"/>	No <input type="checkbox"/>
4.3.1	If so, furnish particulars:		
4.4	Was any contract between the bidder and any organ of state terminated during the past five years on account of failure to perform on or comply with the contract?	Yes <input type="checkbox"/>	No <input type="checkbox"/>



4.4.1	If so, furnish particulars:
-------	-----------------------------

SBD 8

CERTIFICATION

I, THE UNDERSIGNED (FULL NAME)..... CERTIFY THAT THE INFORMATION FURNISHED ON THIS DECLARATION FORM IS TRUE AND CORRECT.

I ACCEPT THAT, IN ADDITION TO CANCELLATION OF A CONTRACT, ACTION MAY BE TAKEN AGAINST ME SHOULD THIS DECLARATION PROVE TO BE FALSE.

.....
Signature

.....
Date

.....
Position

.....
Name of Bidder



CERTIFICATE OF INDEPENDENT BID DETERMINATION

- 1 This Standard Bidding Document (SBD) must form part of all bids¹ invited.
- 2 Section 4 (1) (b) (iii) of the Competition Act No. 89 of 1998, as amended, prohibits an agreement between, or concerted practice by, firms, or a decision by an association of firms, if it is between parties in a horizontal relationship and if it involves collusive bidding (or bid rigging).² Collusive bidding is a *pe se* prohibition meaning that it cannot be justified under any grounds.
- 3 Treasury Regulation 16A9 prescribes that accounting officers and accounting authorities must take all reasonable steps to prevent abuse of the supply chain management system and authorizes accounting officers and accounting authorities to:
 - a. disregard the bid of any bidder if that bidder, or any of its directors have abused the institution's supply chain management system and or committed fraud or any other improper conduct in relation to such system.
 - b. cancel a contract awarded to a supplier of goods and services if the supplier committed any corrupt or fraudulent act during the bidding process or the execution of that contract.
- 4 This SBD serves as a certificate of declaration that would be used by institutions to ensure that, when bids are considered, reasonable steps are taken to prevent any form of bid-rigging.
- 5 In order to give effect to the above, the attached Certificate of Bid Determination (SBD 9) must be completed and submitted with the bid:

¹ Includes price quotations, advertised competitive bids, limited bids and proposals.

² Bid rigging (or collusive bidding) occurs when businesses, that would otherwise be expected to compete, secretly conspire to raise prices or lower the quality of goods and / or services for purchasers who wish to acquire goods and / or services through a bidding process. Bid rigging is, therefore, an agreement between competitors not to compete.



SBD 9

CERTIFICATE OF INDEPENDENT BID DETERMINATION

I, the undersigned, in submitting the accompanying bid:

(Bid Number and Description)

in response to the invitation for the bid made by:

(Name of Institution)

do hereby make the following statements that I certify to be true and complete in every respect:

I certify, on behalf of: _____ that: (Name of Bidder)

1. I have read and I understand the contents of this Certificate;
2. I understand that the accompanying bid will be disqualified if this Certificate is found not to be true and complete in every respect;
3. I am authorized by the bidder to sign this Certificate, and to submit the accompanying bid, on behalf of the bidder;
4. Each person whose signature appears on the accompanying bid has been authorized by the bidder to determine the terms of, and to sign the bid, on behalf of the bidder;
5. For the purposes of this Certificate and the accompanying bid, I understand that the word “competitor” shall include any individual or organization, other than the bidder, whether or not affiliated with the bidder, who:
 - (a) has been requested to submit a bid in response to this bid invitation;
 - (b) could potentially submit a bid in response to this bid invitation, based on their qualifications, abilities or experience; and
 - (c) provides the same goods and services as the bidder and/or is in the same line of business as the bidder
6. The bidder has arrived at the accompanying bid independently from, and without consultation, communication, agreement or arrangement with any competitor. However communication between partners in a joint venture or consortium³ will not be construed as collusive bidding.
7. In particular, without limiting the generality of paragraphs 6 above, there has been no consultation, communication, agreement or arrangement with any competitor regarding:
 - (a) prices;
 - (b) geographical area where product or service will be rendered (market allocation)
 - (c) methods, factors or formulas used to calculate prices;

(c) the intention or decision to submit or not to submit, a bid;



SBD 9

- (e) the submission of a bid which does not meet the specifications and conditions of the bid; or
 - (f) bidding with the intention not to win the bid.
8. In addition, there have been no consultations, communications, agreements or arrangements with any competitor regarding the quality, quantity, specifications and conditions or delivery particulars of the products or services to which this bid invitation relates.
9. The terms of the accompanying bid have not been, and will not be, disclosed by the bidder, directly or indirectly, to any competitor, prior to the date and time of the official bid opening or of the awarding of the contract.
10. I am aware that, in addition and without prejudice to any other remedy provided to combat any restrictive practices related to bids and contracts, bids that are suspicious will be reported to the Competition Commission for investigation and possible imposition of administrative penalties in terms of section 59 of the Competition Act No 89 of 1998 and or may be reported to the National Prosecuting Authority (NPA) for criminal investigation and or may be restricted from conducting business with the public sector for a period not exceeding ten (10) years in terms of the Prevention and Combating of Corrupt Activities Act No 12 of 2004 or any other applicable legislation.

.....
Signature

.....
Date

.....
Position

.....
Name of Bidder



Record of Addenda to Tender Documents

T2. 2-11



RECORD OF ADDENDA TO TENDER DOCUMENTS: WHAG-21-EC

14. I / We confirm that the following communications received from the WILLIAM HUMPHREYS ART GALLERY before the submission of this tender offer, amending the tender documents, have been taken into account in this tender offer: *(Attach additional pages if more space is required)*

	Date	Title or Details
1.		
2.		
3.		
4.		
5.		
6.		
7.		
8.		
9.		
10.		
11.		
12.		
13.		

Name of Tenderer	Signature	Date

15. I / We confirm that no communications were received from the Engineer, Project Manager or Employer before the submission of this tender offer, amending the tender documents.

Name of Tenderer	Signature	Date



Particulars of Electrical Contractor

T2. 2-12



PARTICULARS OF ELECTRICAL CONTRACTOR

We confirm that the **Contractor** contracted to construct are registered with the Electrical Contracting Board of SA, the Department of Employment and Labour and with the CDB (Construction Industry Development Board) in their class of construction.

Name of Contractor:

Address:

Contractor registration number at the Electrical Contracting Board of S.A.:

Name of Tenderer	Signature	Date



Special Conditions of Contract For Subcontracting



SPECIAL CONDITIONS OF TENDER

PROJECT: WILLIAM HUMPHREYS ART GALLERY - UPGRADE OF HVAC SYSTEM

TENDER NO: WB 01/2024

The conditions of tender are the Standard Conditions of Tender as contained in Annex C of Board Notice 423 of 2019 in Government Gazette No. 42622 of 8 August 2019, Construction Industry Development Board (CIDB) Standard for Uniformity in Construction Procurement. (See www.cidb.org.za) which are reproduced without amendment or alteration for the convenience of tenderers as an Annex to this Tender Data. The Standard Conditions of Tender make several references to the Tender Data for details that apply specifically to this tender. The Tender Data shall have precedence in the interpretation of any ambiguity or inconsistency between it and the standard conditions of tender. Each item of data given below is cross-referenced to the clause in the Standard Conditions of Tender to which it mainly applies. The following variations, amendments and additions to the Standard Conditions of Tender as set out in the Tender Data below shall apply to this tender.

Add the following to clauses in Standard Conditions of Tender

The employer's agent is MVD Kalahari Consulting Engineers and Town Planners. Attention is drawn to the fact that verbal information, given by the Employer's agent during site visits/clarification meetings or at any other time prior to the award of the Contract, will not be regarded as binding on the Employer. Only information issued formally by the Employer in writing to Tenderers will be regarded as amending the Tender Documents

A competitive negotiation procedure will not be followed.

A two-stage system will not be followed.

SUBCONTRACTING

SUBCONTRACTING: N/A



Compulsory Enterprise Questionnaire

T2. 2-9



6. Compulsory Enterprise Questionnaire

The following particulars must be furnished. In the case of a joint venture, separate enterprise questionnaires in respect of each partner must be completed and submitted.

Attach to this form the most recent financial statements of the tendering entity.

Section 1: Name of enterprise:

Section 2: VAT registration number, if any:

Section 3: cidb registration number, if any:

Section 4: Particulars of sole proprietors and partners in partnerships

Name*	Identity number*	Personal income tax number*

* Complete only if sole proprietor or partnership and attach separate page if more than 3 partners

Section 5: Particulars of companies and close corporations

Company registration number

Close corporation number

Tax reference number

CSD Number.....

SARS Pin.....

Section 6: Record in the service of the state

Indicate by marking the relevant boxes with a cross, if any sole proprietor, partner in a partnership or director, manager, principal shareholder or stakeholder in a company or close corporation is currently or has been within the last 12 months in the service of any of the following:

- | | |
|--|---|
| <input type="checkbox"/> a member of any municipal council | <input type="checkbox"/> an employee of any provincial department, national or provincial public entity or constitutional institution within the meaning of the Public Finance Management Act, 1999 (Act 1 of 1999) |
| <input type="checkbox"/> a member of any provincial legislature | <input type="checkbox"/> a member of an accounting authority of any national or provincial public entity |
| <input type="checkbox"/> a member of the National Assembly or the National Council of Province | <input type="checkbox"/> an employee of Parliament or a provincial legislature |
| <input type="checkbox"/> a member of the board of directors of any municipal entity | <input type="checkbox"/> an employee or a member of board of directors of cidb |
| <input type="checkbox"/> an official of any municipality or municipal entity | |

If any of the above boxes are marked, disclose the following:

Name of sole proprietor, partner, director, manager, principal shareholder or stakeholder	Name of institution, public office, board or organ of state and position held	Status of service (tick appropriate column)	
		Current	Within last 12 months

*insert separate page if necessary



Section 7: Record of spouses, children and parents in the service of the state

Indicate by marking the relevant boxes with a cross, if any spouse, child or parent of a sole proprietor, partner in a partnership or director, manager, principal shareholder or stakeholder in a company or close corporation is currently or has been within the last 12 months been in the service of any of the following:

- | | |
|--|---|
| <input type="checkbox"/> a member of any municipal council | <input type="checkbox"/> an employee of any provincial department, national or provincial public entity or constitutional institution within the meaning of the Public Finance Management Act, 1999 (Act 1 of 1999) |
| <input type="checkbox"/> a member of any provincial legislature | <input type="checkbox"/> a member of an accounting authority of any national or provincial public entity |
| <input type="checkbox"/> a member of the National Assembly or the National Council of Province | <input type="checkbox"/> an employee of Parliament or a provincial legislature |
| <input type="checkbox"/> a member of the board of directors of any municipal entity | <input type="checkbox"/> an employee or a member of board of directors of CIDB |
| <input type="checkbox"/> an official of any municipality or municipal entity | |

Name of spouse, child or parent	Name of institution, public office, board or organ of state and position held	Status of service (tick appropriate column)	
		Current	Within last 12 months

*insert separate page if necessary

The undersigned, who warrants that he / she is duly authorized to do so on behalf of the enterprise:

- i) authorizes the Employer to obtain a tax clearance certificate from the South African Revenue Services that my / our tax matters are in order;
- ii) confirms that neither the name of the enterprise or the name of any partner, manager, director or other person, who wholly or partly exercises, or may exercise, control over the enterprise appears on the Register of Tender Defaulters established in terms of the Prevention and Combating of Corrupt Activities Act of 2004;
- iii) confirms that no partner, member, director or other person, who wholly or partly exercises, or may exercise, control over the enterprise appears, has within the last five years been convicted of fraud or corruption;
- iv) confirms that I / we are not associated, linked or involved with any other tendering entities submitting tender offers and have no other relationship with any of the tenderers or those responsible for compiling the scope of work that could cause or be interpreted as a conflict of interest; and
- iv) confirms that the contents of this questionnaire are within my personal knowledge and are to the best of my belief both true and correct.

Signed _____ Date _____

Name _____ Position _____

Enterprise name _____



THE CONTRACT



PART C1 : CONTRACT DATA



Contract Data: JBCC 2000 Principal Building Agreement



CONTRACT DATA: JBCC 2000 PRINCIPAL BUILDING AGREEMENT (Edition 4.1 of March 2005)

CONTRACT DATA

WILLIAM HUMPHREYS ART GALLERY - UPGRADE OF HVAC SYSTEM

	<p>The Conditions of Contract are clauses 1 to 41 of the JBCC Series 2000 Principal Building Agreement (Edition 4.1 of March 2005) prepared by the Joint Building Contracts Committee.</p> <p>Copies of these conditions of contract may be obtained through most regional offices of the Association of South African Quantity Surveyors, Master Builders Association, South African Association of Consulting Engineers, South African Institute of Architects, Association of Construction Project Managers, Building Industries Federation South Africa, South African Property Owners Association or Specialist Engineering Contractors Committee.</p>
--	--

	<p>CONTRACT VARIABLES</p> <p>THE SCHEDULE</p> <p>The schedule contains all variables referred to in this document and is divided into part 1: contract data completed by the employer and part 2: contract data completed by the contractor. Part 1 must be completed in full and included in the tender documents. Both the part 1 and part 2 form part of this agreement</p> <p>Spaces requiring information must be filled in, shown as ‘not applicable’ or deleted but not left blank. Where choices are offered, the non-applicable items are to be deleted. Where insufficient space is provided the information should be annexed hereto and cross referenced to the applicable clause of the schedule. Key cross reference clauses are italicized in [] brackets</p>
--	--

42.0	Part 1: Contract Data completed by the Employer:
-------------	---

42.1	CONTRACTING AND OTHER PARTIES
42.1.1	<p><u>Employer:</u></p> <p>William Humphreys Art Gallery, represented by the Accounting Officer</p> <p><u>Postal address:</u></p> <p>William Humphreys Art Gallery 1 Cullinan Crescent CIVIC CENTRE KIMBERLEY, 8300</p> <p>[1.2] Tel: (053) 831 1724/5 Fax: N/A</p> <p><u>Physical address:</u></p> <p>William Humphreys Art Gallery 1 Cullinan Crescent CIVIC CENTRE KIMBERLEY, 8300</p>



<p>42.1.2 [1.1, 5.1]</p>	<p>Professional Project Manager: <u>MVD KALAHARI CONSULTING ENGINEERS AND TOWN PLANNERS</u></p> <p>Agent's service: PROFESSIONAL SERVICE PROVIDER</p> <p>Postal address: 186 Du Toitspan Road KIMBERLEY 8300</p> <p>Tel: 053 831 1889 email: theo@mvdkalahari.co.za</p>
<p>[1.1]</p>	<p><u>Representative of the Employer:</u></p> <p>Project Leader: Mr. T. Semosa</p> <p>Postal address: William Humphreys Art Gallery 1 Cullinan Crescent CIVIC CENTRE KIMBERLEY, 8300</p> <p>Tel: (053) 831 1724/5 Cell: N/A Fax: N/A</p>
<p>42.1.3 [1.1, 5.2]</p>	<p>Agent (1): BVI Consulting Engineers</p> <p>Agent's service: Mechanical Engineering Services</p> <p>Postal address: PO Box 1155 Upington 8801</p> <p>Tel: 054 – 337 6600 email: ricardoh@BVINC.co.za</p>
<p>42.1.3 [1.1, 5.3]</p>	<p>Agent (2):</p> <p>Agent's service:</p> <p>Postal address:</p> <p>Tel:</p> <p>email:</p>
<p>42.1.3 [1.1, 5.4]</p>	<p>Agent (3):</p> <p>Agent's service:</p> <p>Postal address:</p> <p>Tel: Fax:</p> <p>email:</p>



42.2	CONTRACT DETAILS
42.2.1 [1.1]	Works description: Refer to document C3 – Scope of Work.
42.2.2 [1.1]	Site description: Refer to document C4 – Site Information.
42.2.4 [41.0]	Specific options that are applicable to a State organ only Where so :
[1.1 #] [31.11.2 #] [31.12.2#]	1) Interest rate legislation: The interest rate applicable will be as determined by the Minister of Finance, from time to time, in terms of section 80(1)(b) of the Public Finance Management Act, 1999 (Act No. 1 of 1999)
[11.2.#]	2) Lateral support insurance to be affected by the contractor: Yes <input type="checkbox"/> No <input checked="" type="checkbox"/>
[31.4.2 #]	3) Payment will be made for materials and goods Yes <input checked="" type="checkbox"/> No <input type="checkbox"/>
[40.2.2.#]	4) Dispute resolution by Adjudication Yes <input checked="" type="checkbox"/> No <input type="checkbox"/>
[26.1.2 #]	5) Extended defects liability period applicable to the following elements: N/A
42.2.6 [15.3]	Period for the commencement of the works after the contractor takes possession of the site : Ten (10) working days .
42.2.7 [24.3.1] [30.1]	For the works as a whole: Completion will be as follows: The date for practical completion shall be 12 Months from the commencement date and the penalty per calendar day shall be R 4 670.00 for late completion.
42.2.8 [24.3.1] [28.1]	For the works in sections : The date for practical completion from the commencement date and the penalty per calendar day : NOT APPLICABLE Section 1: N/A insert penalty amount: N/A Section 2: N/A insert penalty amount: N/A Section 3: N/A insert penalty amount: N/A Section 4: N/A insert penalty amount: N/A



42.2.9 [1.2]	The law applicable to this agreement shall be that of the: Republic of South Africa
42.3	INSURANCES
42.3.1 [10.1 #, 10.2 # 12.1 #]	Contract works insurance to be effected by the contractor <input checked="" type="checkbox"/> To the minimum value of the contract sum plus 10% With a deductible not exceeding 5% of each and every claim Or <input type="checkbox"/> For the minimum sum of R (.....) With a deductible not exceeding 5% of each and every claim
42.3.2 [10.1 #, 10.2 #, 12.1 #]	Supplementary insurance is required: Yes To the minimum value of the contract sum plus 10 %
42.3.3 [11.1 #, 12.1 #]	Public liability insurance to be effected by the contractor <input checked="" type="checkbox"/> For the sum of R 5 million With a deductible not exceeding 5% of each and every claim Or <input type="checkbox"/> For the sum of R 0 With a deductible not exceeding 5% of each and every claim
42.3.4 [11.2 #, 12.1 #]	Support insurance to be effected by the contractor For the sum of R 0 With a deductible of R 0

42.4	DOCUMENTS
42.4.1	Waiver of contractors lien or right of continuing possession is required .
42.4.2 [3.7]	Three (3) copies of the construction documents will be supplied to the contractor free of charge
42.4.3	Bills of quantities / Lump sum document schedule of rates drawn up in accordance with: <input checked="" type="checkbox"/> Standard System of Measuring Building Work (sixth edition as amended) Or <input type="checkbox"/> Standard System of Measuring Building Work for Small or Simple Buildings 1999 Or <input type="checkbox"/> Other) <i>Specific Project Specification forming part of this document. It will take preference over any contradictory items in the standard SABS/SANS 1200.</i>



<p>42.4.5 [3.4]</p>	<p>JBCC Engineering General Conditions are to be included in the contract documents: Yes</p>
<p>42.4.6 [31.5.3] [32.13]</p>	<p>The contract value is to be adjusted using CPAP indices: [No]</p> <p>Where CPAP is applicable, the contract sum will be adjusted in accordance with the JBCC Contract Price Adjustment Provisions (CPAP) as set out in the CPAP Indices Application Manual as prepared by the JBCC Series 2000, code 2118, dated May 2005 and any amendments thereto:</p> <ol style="list-style-type: none"> 1) Glass etc. measured in specialist section Metalwork, will be adjusted in terms of the index for that work group unless specifically stated otherwise in the bills of quantities 2) All electrical installations in buildings and power distribution systems shall be adjusted in terms of the index for Work Group 160 Electrical Installation. In case of uninterruptible power supplies, elevators, escalators and hoists, generating sets, motor-alternator sets and intercommunication systems shall be in accordance with Work Group 170 3) With reference to Work Group 190 a proportion of the value related preliminaries pro rata to the amount of work excluded from adjustment, shall be excluded from Contract Price Adjustment Provisions, if Option A has been selected for the adjustment of preliminaries 4) Further to clause 3.4.4 of the CPAP Indices Application Manual, the listing of additional items for exclusion by tenderers, will not be permitted 5) Where V results in a negative amount after application of the formula in clause 8.3 of the CPAP Indices Application Manual the factor of 0,55 shall be substituted by 1,45 <p>Alternative Indices: Not Applicable</p>
<p>42.4.7 [3.10]</p>	<p>Details of changes made to the provisions of JBCC standard documentation</p> <p>Clause</p> <p>1.1 COMMENCEMENT DATE – means the date that the agreement, made in terms of the Form of Offer and Acceptance, comes into effect</p> <p>CONSTRUCTION GUARANTEE – means a guarantee at call obtained by the contractor from an institution approved by the employer in terms of the employer’s construction guarantee form as selected in the schedule</p> <p>CONSTRUCTION PERIOD – means the period commencing on the commencement date and ending on the date of practical completion</p> <p>CORRUPT PRACTICE – means the offering, giving, receiving, or soliciting of anything of value to influence the action of a public official in the procurement process or in contract execution</p> <p>FRAUDULENT PRACTICE – means a misrepresentation of facts in order to influence a procurement process or the execution of a contract to the detriment of any tenderer, and includes collusive practice among tenderers (prior to or after the tender submission) designed to establish tender prices at artificial non-competitive levels and to deprive the tenderer of the benefits of free and open competition</p> <p>INTEREST – the interest rates applicable on this contract, whether specifically indicated in the relevant clauses or not, will be the rate as determined by the Minister of Finance, from time to time, in terms of section 80(1)(b) of the Public Finance Management Act, 1999 (Act No. 1 of 1999)</p> <p>PROFESSIONAL SERVICE PROVIDER – means the person or entity appointed by the employer and named in the schedule. In the event of a Professional Service Provider not being appointed, then all the duties and obligations of a Professional Service Provider as detailed in the agreement shall be fulfilled by a representative of the employer as named in the schedule</p>



	<p>SECURITY – means the form of security provided by the employer or contractor, as stated in the schedule, from which the contractor or employer may recover expense or loss</p> <p>1.6 Any notice given may be delivered by hand, sent by prepaid registered post or telefax. Notice shall be presumed to have been duly given when:</p> <p>1.6.4 No clause</p> <p>3.2.1 A construction guarantee in terms of 14.0, where so elected in his tender</p> <p>3.7 Add at the end thereof:</p> <p>The contractor shall supply and keep a copy of the JBCC Series 2000 Principal Building Agreement and Preliminaries applicable to this contract on the site, to which the employer, Professional Service Provider and agents shall have access at all times.</p> <p>3.10 Replace the second reference to “Professional Service Provider” with the word “employer”</p> <p>4.3 No clause</p> <p>5.1.2 under clause 41- Include reference to 32.6.3; 34.3; 34.4 and 38.5.8 in terms of which the employer has retained its authority and has not given a mandate to the Professional Service Provider and in terms of which the employer shall sign all documents</p> <p>10.5 Add the following as 10.5</p> <p>Damage to the works</p> <p>(1) Without in any way limiting the contractor’s obligations in terms of the contract, the contractor shall bear the full risk of damage to and/or destruction of the works by whatever cause during construction of the works and hereby indemnifies and holds harmless the employer against any such damage. The contractor shall take such precautions and security measures and other steps for the protection and security of the works as the contractor may deem necessary</p> <p>(2) The contractor shall at all times proceed immediately to remove or dispose of any debris arising from damage to or destruction of the works and to rebuild, restore, replace and/or repair the works</p> <p>(3) The employer shall carry the risk of damage to or destruction of the works and materials paid for by the employer that is the result of the excepted risks as set out in 10.6</p> <p>(4) Where the employer bears the risk in terms of this contract, the contractor shall, if requested to do so, reinstate any damage or destroyed portions of the works and the costs of such reinstatement shall be measured and valued in terms of 32.0 hereof</p> <p>10.6 Add the following as 10.6</p> <p>Injury to Persons or loss of or damage to Properties</p> <p>(a) The contractor shall be liable for and hereby indemnifies the employer against any liability, loss, claim or proceeding whether arising in common law or by statute, consequent upon personal injuries to or the death of any person whomsoever arising out of or in the course of or caused by the execution of the works unless due to any act or negligence of any person for whose actions the employer is legally liable</p> <p>(b) The contractor shall be liable for and hereby indemnifies the employer against any liability, loss, claim or proceeding consequent upon loss of or damage to any moveable, or immovable property or personal property or property contiguous to the site, whether belonging to or under the control of the employer or any other body or person, arising out of or in the course of or by reason of the execution of the works</p>
--	--



unless due to any act or negligence of any person for whose actions the **employer** is legally liable

- (c) The **contractor** shall upon receiving a **contract instruction** from the **Professional Service Provider** cause the same to be made good in a perfect and workmanlike manner at his own cost and in default thereof the **employer** shall be entitled to cause it to be made good and to recover the cost thereof from the **contractor** or to deduct the same from amounts due to the **contractor**
- (d) The **contractor** shall be responsible for the protection and safety of such portions of the premises placed under his control by the **employer** for the purpose of executing the **works** until the issue of the **certificate of practical completion**
- (5) Where the execution of the **works** involves the risk of removal of or interference with support to adjoining properties including land or structures or any structures to be altered or added to, the **contractor**, shall obtain adequate insurance and will remain adequately insured or insured to the specific limit stated in the contract against the death of or injury to persons or damage to such property consequent on such removal or interference with the support until such portion of the **works** has been completed
- (6) The **contractor** shall at all times proceed immediately at his own cost to remove or dispose of any debris and to rebuild, restore, replace and/or repair such property and to execute the **works**

10.7 Add the following as 10.7

HIGH RISK INSURANCE

In the event of the project being executed in a geological area classified as a “High Risk Area”, that is an area which is subject to highly unstable subsurface conditions that might result in catastrophic ground movement evident by sinkhole or doline formation the following will apply:

10.7.1 Damage to the works

The **contractor** shall, from the **commencement date** of the **works** until the date of the **certificate of practical completion**, bear the full risk of and hereby indemnifies and holds harmless the **employer** against any damage to and/or destruction of the **works** consequent upon a catastrophic ground movement as mentioned above. The **contractor** shall take such precautions and security measures and other steps for the protection of the **works** as he may deem necessary

When so instructed to do so by the **Professional Service Provider**, the **contractor** shall proceed immediately to remove and/or dispose of any debris arising from damage to or destruction of the **works** and to rebuild, restore, replace and/or repair the **works**, at the **contractor’s** own costs

10.7.2 Injury to persons or loss of or damage to property

The **contractor** shall be liable for and hereby indemnifies and holds harmless the **employer** against any liability, loss, claim or proceeding arising at any time during the period of the contract whether arising in common law or by statute, consequent upon personal injuries to or the death of any person whomsoever resulting from, arising out of or caused by a catastrophic ground movement as mentioned above

The **contractor** shall be liable for and hereby indemnifies the **employer** against any and all liability, loss, claim or proceeding consequent upon loss of or damage to any moveable, or immovable property or personal property or property contiguous to the **site**, whether belonging to or under the control of the **employer** or any other body or person whomsoever arising out of or caused by a catastrophic ground movement, as mentioned above, which occurred during the period of the contract

10.7.3 It is the responsibility of the **contractor** to ensure that he has adequate insurance to cover his risk and liability as mentioned in 10.7.1 and 10.7.2. Without limiting the **contractor’s**

obligations in terms of the contract, the **contractor** shall, within twenty one (21) **calendar days** of the **commencement date** but before commencement of the **works**, submit to the **employer** proof of such insurance policy, if requested to do so

10.7.4 The **employer** shall be entitled to recover any and all losses and/or damages of whatever nature suffered or incurred consequent upon the **contractor's** default of his obligations as set out in 10.7.1; 10.7.2 and 10.7.3. Such losses or damages may be recovered from the **contractor** or by deducting the same from any amounts still due under this contract or under any other contract presently or hereafter existing between the **employer** and the **contractor** and for this purpose all these contracts shall be considered one indivisible whole

14.0 Replace the entire clause 14.0 with the following:

14.0 SECURITY

14.1 In respect of contracts with a **contract sum** up to R1 million, the **security** to be provided by the **contractor** to the **employer** will be a payment reduction of five per cent (5%) of the value certified in the **payment certificate** (excluding VAT)

14.1.1 The payment reduction of the value certified in a **payment certificate** shall be *mutatis mutandi* in terms of 31.8(A)

14.1.2 The **employer** shall be entitled to recover expense and loss from the payment reduction in terms of 33.0 provided that the **employer** complies with the provisions of 33.4 in which event the **employer's** entitlement shall take precedence over his obligations to refund the payment reduction **security** or portions thereof to the **contractor**

14.2 In respect of contracts with a **contract sum** above R1 million, the **contractor** shall have the right to select the **security** to be provided in terms of 14.3, 14.4, 14.5, 14.6, or 14.7 as stated in the **schedule**. Such **security** shall be provided to the **employer** within twenty-one (21) **calendar days** from **commencement date**. Should the **contractor** fail to select the **security** to be provided or should the **contractor** fail to provide the **employer** with the selected **security** within twenty-one (21) **calendar days** from **commencement date**, the **security** in terms of 14.7 shall be deemed to have been selected.

14.3 Where the **security** as a cash deposit of ten per cent (10%) of the **contract sum** (excluding VAT) has been selected:

14.3.1 The **contractor** shall furnish the **employer** with a cash deposit equal in value to ten per cent (10%) of the **contract sum** (excluding VAT) within twenty-one (21) **calendar days** from **commencement date**

14.3.2 Within twenty-one (21) **calendar days** of the date of **practical completion** of the **works** the **employer** shall reduce the cash deposit to an amount equal to three per cent (3%) of the **contract value** (excluding VAT), and refund the balance to the **contractor**

14.3.3 Within twenty-one (21) **calendar days** of the date of **final completion** of the **works** the **employer** shall reduce the cash deposit to an amount equal to one per cent (1%) of the **contract value** (excluding VAT) and refund the balance to the **contractor**

14.3.4 On the date of payment of the amount in the final **payment certificate**, the **employer** shall refund the remainder of the cash deposit to the **contractor**

14.3.5 The **employer** shall be entitled to recover expense and loss from the cash deposit in terms of 33.0 provided that the **employer** complies with the provisions of 33.4 in which event the **employer's** entitlement shall take precedence over his obligations to refund the cash deposit **security** or portions thereof to the **contractor**

- 14.3.6 The parties expressly agree that neither the **employer** nor the **contractor** shall be entitled to cede the rights to the deposit to any third party
- 14.4 Where **security** as a variable **construction guarantee** of ten percent (10%) of the **contract sum** (excluding VAT) has been selected:
- 14.4.1 The **contractor** shall furnish the **employer** with an acceptable variable **construction guarantee** equal in value to ten per cent (10%) of the **contract sum** (excluding VAT) within twenty-one (21) **calendar days** from **commencement date**
- 14.4.2 The variable **construction guarantee** shall reduce and expire in terms of the Variable **Construction Guarantee** form included in the invitation to tender
- 14.4.3 The **employer** shall return the variable **construction guarantee** to the **contractor** within fourteen (14) **calendar days** of it expiring
- 14.4.4 Where the **employer** has a right of recovery against the **contractor** in terms of 33.0, the **employer** shall issue a written demand in terms of the variable **construction guarantee**
- 14.5 Where **security** as a fixed **construction guarantee** of five per cent (5%) of the **contract sum** (excluding VAT) and a five per cent (5%) payment reduction of the value certified in the **payment certificate** (excluding VAT) has been selected:
- 14.5.1 The **contractor** shall furnish a fixed **construction guarantee** to the **employer** equal in value to five per cent (5%) of the **contract sum** (excluding VAT)
- 14.5.2 The fixed **construction guarantee** shall come into force on the date of issue and shall expire on the date of the last certificate of **practical completion**
- 14.5.3 The **employer** shall return the fixed **construction guarantee** to the **contractor** within fourteen (14) **calendar days** of it expiring
- 14.5.4 The payment reduction of the value certified in a **payment certificate** shall be in terms of 31.8(A) and 34.8
- 14.5.5 Where the **employer** has a right of recovery against the **contractor** in terms of 33.0, the **employer** shall be entitled to issue a written demand in terms of the fixed **construction guarantee** or may recover from the payment reduction or may do both
- 14.6 Where **security** as a cash deposit of five per cent (5%) of the **contract sum** (excluding VAT) and a payment reduction of five per cent (5%) of the value certified in the **payment certificate** (excluding VAT) has been selected:
- 14.6.1 The **contractor** shall furnish the **employer** with a cash deposit equal in value to five per cent (5%) of the **contract sum** (excluding VAT) within twenty-one (21) **calendar days** from **commencement date**
- 14.6.2 Within twenty-one (21) **calendar days** of the date of **practical completion** of the **works** the **employer** shall refund the cash deposit in total to the **contractor**
- 14.6.3 The payment reduction of the value certified in a **payment certificate** shall be *mutatis mutandi* in terms of 31.8(A)
- 14.6.4 Where the **employer** has a right of recovery against the **contractor** in terms of 33.0, the **employer** may issue a written notice in terms of 33.4 or may recover from the payment reduction or may do both
- 14.7 Where **security** as a payment reduction of ten per cent (10%) of the value certified in the **payment certificate** (excluding VAT) has been selected:
- 14.7.1 The payment reduction of the value certified in a **payment certificate** shall be *mutatis mutandi* in terms of 31.8(B)

- 14.7.2 The **employer** shall be entitled to recover expense and loss from the payment reduction in terms of 33.0 provided that the **employer** complies with the provisions of 33.4 in which event the **employer's** entitlement shall take precedence over his obligations to refund the payment reduction or portions thereof to the **contractor**
- 14.8 Payments made by the guarantor to the **employer** in terms of the fixed or variable **construction guarantee** shall not prejudice the rights of the **employer** or **contractor** in terms of this **agreement**
- 14.9 Should the **contractor** fail to furnish the **security** in terms of 14.2 the **employer**, in his sole discretion, and without notification to the **contractor**, is entitled to change the **contractor's** selected form of **security** to that of a ten per cent (10%) payment reduction of the value certified in the **payment certificate** (excluding VAT), whereafter 14.7 shall be applicable
- 15.1.1 No clause
- 15.1.2 The **security** selected in terms of 14.0
- 15.1.4 Add 15.1.4 as follows:
- An acceptable health and safety plan, required in terms of the Occupational Health and Safety Act, 1993 (Act 85 of 1993 as amended), within twenty-one (21) **calendar days** of **site handover date**
- 15.2.1 Under 41: Amend to read as follows:
- “Give the **contractor** possession of the **site** within ten (10) **working days** of the **commencement date**.”
- 17.1.11 Delete the words “and the appointment of **nominated** and **selected sub-contractors**”
- 20.1.3 No clause
- 21.0 No clause
- 26.1.2 Add # next to 26.1.2
- 29.2.5 No clause
- 31.5.2 Security adjustments in terms of 14.0 or 31.8
- 31.8 Amend as follows:
- 31.8(A) Where a **security** is selected in terms of 14.1; 14.5 or 14.6, the value of the **works** in terms of 31.4.1 and of the **materials and goods** in terms of 31.4.2 shall be certified in full. The value certified shall be subject to the following percentage adjustments:
- 31.8(A).1 Ninety-five per cent (95%) of such value in interim **payment certificates** issued up to the date of **practical completion**
- 31.8(A).2 Ninety-seven per cent (97%) of such value in interim **payment certificates** issued on the date of **practical completion** and up to but excluding the date of **final completion**
- 31.8(A).3 Ninety-nine per cent (99%) of such value in interim **payment certificates** issued on the date of **final completion** and up to but excluding the final **payment certificate** in terms of 34.6
- 31.8(A).4 One hundred per cent (100%) of such value in the final **payment certificate** in terms of 34.6 except where the amount certified is in favour of the **employer**. In such an event the payment reduction shall remain at the adjustment level applicable to the final **payment certificate**.

	<p>31.8(B) Where security is a payment reduction in term of 14.7 has been selected the value of the works in terms of 31.4.1 and materials and goods in terms of 31.4.2 shall be certified in full. The value certified shall be subject to the following percentage adjustments:</p> <p>31.8(B).1 Ninety per cent (90%) of such value in interim payment certificates issued up to the date of practical completion</p> <p>31.8(B).2 Ninety-seven per cent (97%) of such value in interim payment certificates issued on the date of practical completion and up to but excluding the date of final completion</p> <p>31.8(B).3 Ninety-nine per cent (99%) of such value in interim payment certificates issued on the date of final completion and up to but excluding the final payment certificate in terms of 34.6</p> <p>31.8(B).4 One hundred per cent (100%) of such value in the final payment certificate in terms of 34.6 except were the amount certified is in favour of the employer. In such an event the payment reduction shall remain at the adjustment level applicable to the final payment certificate</p> <p>31.12 Delete the following: "Payment shall be subject to the employer giving the contractor a tax invoice for the amount due."</p> <p>32.5.1 Add the following to the end of each of these clauses: "...due to no fault of the 32.5.4 contractor" and 32.5.7</p> <p>34.1 Remove #</p> <p>34.2 Add # next to 34.2</p> <p>34.8 The Professional Service Provider shall certify one hundred per cent (100%) of the amount of the final account in the final payment certificate</p> <p>34.13 Replace "seven (7) calendar days" with "twenty one (21) calendar days" and delete the words: "subject to the employer giving the contractor a tax invoice for the amount due"</p> <p>36.1 Add the following clauses 36.1.3 to 36.1.5. under 36.1 to read as follows:</p> <p>36.1.3 refuses or neglects to comply strictly with any of the conditions of contract</p> <p>36.1.4 estate being sequestrated; liquidated or surrendered in terms of the insolvency laws in force within the Republic of South Africa</p> <p>36.1.5 in the judgment of the employer, has engaged in corrupt or fraudulent practices in competing for or in executing the contract</p> <p>36.3 Remove reference to "No clause", and replace "Professional Service Provider" with "employer"</p> <p>36.7 Add the following: "Notwithstanding any clause to the contrary, on cancellation of this 37.5 agreement either by the employer or the contractor; or for any reason whatsoever, and the contractor shall on written instruction, discontinue with the works on a date stated 38.7 and withdraw himself from the site. The contractor shall not be entitled to refuse to withdraw from the works on the grounds of any lien or right of retention or on the grounds of any other right whatsoever"</p> <p>37.3.5 Replace "ninety (90)" with "one hundred and twenty (120) And 38.5.4</p>
--	--



	<p>39.3.5 Add the following words at the end thereof: “within one hundred and twenty (120) working days of completion of such a report”</p> <p>40.2.2 under clause 41 – Replace “one (1) year” with “three (3) years”</p> <p>40.6 under clause 41 – Remove reference to no clause</p> <p>40.7.1 Change “(10)” to “(15)”</p> <p>Add the following to the end thereof:</p> <p>Whether or not mediation resolves the dispute, the parties shall bear their own costs concerning the mediation and equally share the costs of the mediator and related costs.</p>
--	---

42.0	Part 2: Contract Data provided by the Contractor:
42.5	CONTRACT DETAILS
42.5.1	<p>Contractor:</p> <p>Postal address:</p> <p>_____</p> <p>_____</p> <p>_____</p> <p>Tel: _____</p> <p>TAX / VAT Registration No: _____</p> <p>Physical address:</p> <p>_____</p> <p>_____</p> <p>_____</p>



42.5.2	The accepted contract sum inclusive of tax is R _____ Amount in words: _____
42.5.3 [31.3]	The latest day of the month for the issue of an interim payment certificate : _____
42.5.4 [32.12]	The preliminaries amounts shall be paid in terms of: Alternative A <input type="checkbox"/> Alternative B <input type="checkbox"/>
42.5.5 [32.12]	The preliminaries amounts shall be adjusted in terms of: Alternative A <input type="checkbox"/> Alternative B <input type="checkbox"/>

42.5.7 [14]	<p>The security to be provided by the contractor:</p> <p>(a) in respect of contracts up to R1 million, the contractor will provide security in terms of 14.1</p> <p>(b) in respect of contracts above R1 million, the contractor will provide, as security, one of the following:</p> <p>(1) cash deposit of 10 % of the contract sum (excluding VAT) Yes <input type="checkbox"/> No <input type="checkbox"/></p> <p>(2) variable construction guarantee of 10 % of the contract sum (excluding VAT) (WHAG-10.3 EC) Yes <input type="checkbox"/> No <input type="checkbox"/></p> <p>(3) payment reduction of 10% of the value certified in the payment certificate (excluding VAT) Yes <input type="checkbox"/> No <input type="checkbox"/></p> <p>(6) cash deposit of 5% of the contract sum (excluding. VAT) and a payment reduction of 5% of the value certified in the payment certificate (excluding. VAT) Yes <input type="checkbox"/> No <input type="checkbox"/></p> <p>(7) fixed construction guarantee of 5% of the contract sum (excluding VAT) and a payment reduction of 5% of the value certified in the payment certificate (excluding VAT) (WHAG-10.1 EC) Yes <input type="checkbox"/> No <input type="checkbox"/></p> <p>NB. Guarantees submitted must be issued by either an insurance company duly registered in terms of the Short-Term Insurance Act, 1998 (Act 35 of 1998) or by a bank duly registered in terms of the Banks Act, 1990 (Act 94 of 1990) on the pro-forma referred to above. No alterations or amendments of the wording of the pro-forma will be accepted.</p>
42.5.8 [29.7.2]	The annual building holiday period after the commencement of the construction period : From: _____ to _____



<p>42.6</p> <p>42.6.1</p>	<p>DOCUMENTS</p> <p>Contract documents marked and annexed hereto:</p> <p>Priced bills of quantities: Yes <input type="checkbox"/> No <input type="checkbox"/> Document marked as: _____</p> <p>Lump sum document: Yes <input type="checkbox"/> No <input type="checkbox"/> Document marked as: _____</p> <p>Guarantees: Yes <input type="checkbox"/> No <input type="checkbox"/> Document marked as: _____</p> <p>Contract drawings: Yes <input type="checkbox"/> No <input type="checkbox"/> Document marked as: _____</p> <p>Other documents: Yes <input type="checkbox"/> No <input type="checkbox"/> (<i>Attach additional pages if more space is required</i>)</p> <p>_____</p> <p>_____</p> <p>_____</p> <p>_____</p> <p>_____</p> <p>_____</p>
----------------------------------	--



Fixed Construction Guarantee – JBCC



FIXED CONSTRUCTION GUARANTEE
JBCC 2000 PRINCIPAL BUILDING AGREEMENT
(Edition 4.1 of March 2005)

WHAG 10.1

THE CFO
WILLIAM HUMPHREYS ART GALLERY
AN AGENCY OF THE DEPARTMENT OF SPORTS ARTS AND CULTURE

TO: CFO - Mr M Ramafalo

Madam,

**FIXED CONSTRUCTION GUARANTEE FOR THE EXECUTION OF A CONTRACT
IN TERMS OF JBCC 2000 (4.1 EDITION MARCH 2005)**

1. With reference to the contract between _____
_____ (hereinafter referred to as the
“**contractor**”) and the Government of the Republic of South Africa in its WILLIAM HUMPHREYS ART GALLERY
(hereinafter referred to as the “**employer**”), Contract/Tender No: WB 01/2024 for WILLIAM HUMPHREYS ART
GALLERY - UPGRADE OF HVAC SYSTEM (hereinafter referred to as the “**contract**”) in the amount of
R _____, (_____),
(hereinafter referred to as the **contract sum**),

I / We, _____ in my/our capacity
as _____ and _____ hereby representing
_____ (hereinafter referred to as the “**guarantor**”) advise that the
guarantor holds at the **employer’s** disposal the sum of R _____,
(_____)
being 10% of the **contract sum** (excluding VAT), for the due fulfilment of the contract.
2. The **guarantor** hereby renounces the benefits of the exceptions *non numeratae pecunia; non causa debiti; excussionis et divisionis*; and all other exceptions which could be pleaded against the enforcement of this guarantee, with the meaning and effect whereof I/we declare myself/ourselves to be conversant, and undertake to pay the **employer** the amount guaranteed, during the period when the claim is received by the **guarantor**, on receipt of a written demand from the **employer** to do so, and which demand the **employer** may make if the **employer** has a right of recovery against the **contractor** in terms of 33.0 of the contract.
3. Subject to the above, but without in any way detracting from the **employer’s** rights to adopt any of the procedures provided for in the contract, the said demand can be made by the **employer**, at any stage prior to the expiry of this guarantee.
4. The amount paid by the **guarantor** in terms of this guarantee may be retained by the **employer** on condition that upon the issue of the last final **payment certificate**, the **employer** shall account to the **guarantor** showing how this amount has been expended and refund any balance due to the **guarantor**.
5. The **employer** shall have the absolute right to arrange his affairs with the **contractor** in any manner which the **employer** deems fit and the **guarantor** shall not have the right to claim his release on account of any conduct alleged to be prejudicial to the **guarantor**. Without derogating from the foregoing, any compromise, extension of the **construction period**, indulgence, release or variation of the **contractor’s** obligation shall not affect the validity of this guarantee.
6. This undertaking is neither negotiable nor transferable, and
 - (a) must be surrendered to the **guarantor** at the time when the **employer** accounts to the **guarantor** in terms of clause 4 above, or
 - (b) shall lapse on the date of the last **certificate of practical completion**; and
 - (c) shall not be interpreted as extending the **guarantor’s** liability to anything more than payment of the amount guaranteed.



SIGNED AT _____ ON THIS _____ DAY OF _____ 2024

By and on behalf of

(insert the name and physical address of the guarantor)

NAME: _____

CAPACITY: _____
(duly authorised thereto by resolution attached marked Annexure A)

DATE: _____

AS WITNESS

1. _____

2. _____

- A. No alterations and/or additions of the wording of this form will be accepted.
- B. The physical address of the guarantor must be clearly indicated and will be regarded as the guarantor's *domicilium citandi et executandi*, for all purposes arising from this guarantee.
- C. This GUARANTEE must be returned to: _____



Variable Construction Guarantee – JBCC



VARIABLE CONSTRUCTION GUARANTEE
JBCC 2000 PRINCIPAL BUILDING AGREEMENT

WHAG 10.3

(Edition 4.1 of March 2005)

THE CFO
WILLIAM HUMPHREYS ART GALLERY
AN AGENCY OF THE DEPARTMENT OF SPORTS ARTS AND CULTURE

TO: CFO - Mr M Ramafalo

Madam,

VARIABLE CONSTRUCTION GUARANTEE FOR THE EXECUTION OF A CONTRACT IN TERMS OF JBCC 2000
(4.1 EDITION MARCH 2005)

5. With reference to the contract between _____
_____ (hereinafter referred to as the
“**contractor**”) and the Government of the Republic of South Africa, in its WILLIAM HUMPHREYS ART GALLERY,
(hereinafter referred to as the “**employer**”), Contract/Tender No: WB 002/2023 for the WILLIAM HUMPHREYS
ART GALLERY - UPGRADE OF HVAC SYSTEM (hereinafter referred to as the “**contract**”) in the amount of
R _____, (_____)
(hereinafter referred to as the **contract sum**),

I / We, _____
in my/our capacity as _____ and hereby representing
_____ (hereinafter referred to as the “**guarantor**”) advise that the
guarantor holds at the **employer’s** disposal the sum of R _____,
(_____)
being 10% of the **contract sum** (excluding VAT), for the due fulfilment of the contract.

6. I / We advise that the **guarantor’s** liability in terms of this guarantee shall be reduced as follows:
- (a) From and including the date on which this guarantee is issued and up to and including the date of payment of the amount in the last final **payment certificate**, the **guarantor** will be liable in terms of this guarantee to the maximum amount of 10% of the **contract sum** (excluding VAT);
 - (b) From and including the day after the date of the last **certificate of practical completion** and up to and including the date of the last **final completion** certificate, the **guarantor’s** liability will be reduced to 3% of the value of the works (excluding VAT);
 - (c) From and including the day after the date of the last **final completion** certificate and up to and including the date of settlement of the amount in the last final **payment certificate**, the **guarantor’s** liability will be reduced to 1% of the value of the works (excluding VAT);

(d) This guarantee shall expire on the date of payment of the amount in the last final payment certificate.

7. The **guarantor** hereby renounces the benefits of the exceptions *non numeratae pecunia; non causa debiti; excussionis et divisionis*; and all other exceptions which could be pleaded against the enforcement of this guarantee, with the meaning and effect whereof I/we declare myself/ourselves to be conversant, and undertake to pay the **employer** the amount guaranteed, during the period when the claim is received by the **guarantor**, on receipt of a written demand from the **employer** to do so, and which demand the **employer** may make if the **employer** has a right of recovery against the **contractor** in terms of 33.0 of the contract.

(a) Subject to the above, but without in any way detracting from the employer’s rights to adopt any of the procedures provided for in the contract, the said demand can be made by the employer at any stage prior to the expiry of this guarantee.



- (b) The amount paid by the guarantor in terms of this guarantee may be retained by the employer on condition that upon the issue of the last final payment certificate, the employer shall account to the guarantor showing how this amount has been expended and refund any balance due to the guarantor.
- (c) The employer shall have the absolute right to arrange his affairs with the contractor in any manner which the employer deems fit and the guarantor shall not have the right to claim his release on account of any conduct alleged to be prejudicial to the guarantor. Without derogating from the foregoing, any compromise, extension of the construction period, indulgence, release or variation of the contractor’s obligation shall not affect the validity of this guarantee.
- (d) This undertaking is neither negotiable nor transferable, and
- (e) must be surrendered to the guarantor at the time when the employer accounts to the guarantor in terms of clause 5 above, or
- (f) shall lapse in accordance with clause 2(d) above; and
- (g) shall not be interpreted as extending the guarantor’s liability to anything more than the payment of the amount guaranteed.

SIGNED AT _____ **ON THIS** _____ **DAY OF** _____ **2024**

By and on behalf of

(insert the name and physical address of the guarantor)

NAME: _____

CAPACITY: _____
(duly authorised thereto by resolution attached marked Annexure A)

DATE: _____

AS WITNESS

3. _____

4. _____

D. No alterations and/or additions of the wording of this form will be accepted

E. The physical address of the guarantor must be clearly indicated and will be regarded as the guarantor’s *domicilium citandi et executandi*, for all purposes arising from this guarantee.

F. This GUARANTEE must be returned to: _____



PART C2: PRICING DATA



PRICING INSTRUCTIONS

JBCC 2000 PRINCIPAL BUILDING AGREEMENT

(Edition 4.1 of March 2005)

C2.1 Pricing Instructions

1. BILLS OF QUANTITIES

The pricing strategy adopted for this project is the **provisional bills of quantities** which forms part of and must be read and priced in conjunction with all the other documents forming part of the **contract documents**, the Standard Conditions of Tender, Conditions of Contract, Specifications, Drawings and all other relevant documentation.

The Standard System of Measuring Building Work referred to in Clause 41.4.3 of Section 1: Preliminaries (Section A), has reference. Except where stated otherwise or where it is clear from the contents of the measured items, these bills of quantities have been compiled in accordance with the "Standard System of Measuring Building Work" 6 th edition (as amended), issued by the Association of South African Quantity Surveyors. All measurements and payments will be done in accordance with the principles as laid down in the said Standard System of Measuring Building Work.

2. GENERAL PREAMBLES

For further amplification of descriptions of materials to be used and methods to be adopted, the contractor is referred to the Specification of Materials and Methods to be used (PW371) as published by the Department of Public Works (fourth revision, October 1993), the relevant descriptions which shall be deemed to be read and priced in conjunction with the descriptions in the **provisional bills of quantities**. No claims arising from brevity of description of items fully described in the said specification will be entertained.

The document Specification of Materials and Methods to be used (PW371) is obtainable on request from the head office and all regional offices of the Department.

3. ORDERING OF MATERIALS

The Contractor shall place orders timeously for materials or specified articles that are required. Should the **bills of quantities** be used for ordering materials, this shall be entirely at the contractor's risk.

4. IMPORTED MATERIALS AND EQUIPMENT

Where imported items are listed in the tender documents, the tenderer shall provide all the information called for, failing which the price of any such item, material or equipment shall be excluded from currency fluctuations. (Refer to form DPW-23 EC for the Schedule of imported materials and equipment to be completed by the tenderer).

Notwithstanding any provisions elsewhere regarding the adjustment of contract prices, the price of any item, material or equipment listed in terms of this clause shall be excluded from the Contract Price Adjustment Provisions (if applicable).

5. VALUE ADDED TAX

The tender price must include for Value Added Tax (VAT). All rates, provisional sums, etc. in the **bills of quantities** must however be net (exclusive of VAT) with VAT calculated and added to the Total Value thereof in the Final Summary.

6. PRIME COST AMOUNTS

Prime cost amounts are a net allowance, excluding VAT, for materials only, and the tenderer should allow for the necessary labour, wastage, profit, etc in pricing these items.



7. EXISTING SERVICES

During construction in the various areas, it is anticipated that unknown live services will be exposed and temporary deviations will need to be constructed. The Contractor will be deemed to have made due allowance in his programming and pricing of the Bills of Quantities for possible delays due to the existence of unknown live services and no extension of time claims will be entertained in this regard.

8. SECURITY

The Contractor is to provide for his own site security and is to co-ordinate overall site security with any Nominated Sub-Contractors.

9. ACTS OF PARLIAMENT, ORDINANCES, REGULATIONS AND BY-LAWS AND OCCUPATIONAL HEALTH AND SAFETY ACT (ACT 85 OF 1993 – SECTION 37 [2])

Reference made to, or requirements called for in terms of the provisions of any Act of Parliament, Ordinance and the Regulations or By-Laws of any local or other statutory authority shall not in any way limit the Tenderer / Contractor's liability or obligations to familiarise himself with and comply with the provisions of all Acts of Parliament, Ordinances and the Regulations or By-Laws of any local or other statutory authority which may be applicable.

The Tenderer's attention is drawn to the fact that the Occupational Health and Safety Act (Act 85 of 1993 – Section 37[2]) is in force. Copies of the Act as well as the Construction Regulations 2003, issued in terms of the Act, are available from the Government Printing Works, 149 Bosman Street, Pretoria (Private Bag X85, Pretoria, 0001. Tel. 012 – 334 4500)

The Contractor is to provide the appropriate number of Safety Officers required for the execution of the full project and for the duration of the entire contract.

These Bills of Quantities contain items relating to the Construction Regulations, 2003 issued under the Occupational Health and Safety Act, 1993 (Act 85 of 1993). Tenderers must price separately all the relevant items under clause C11 of the Preliminaries to enable the Department to ensure that tenderers have made provision for the cost of all health and safety measures during the construction process.

10. CONTRACT PRICE ADJUSTMENT PROVISIONS (ESCALATION)

This Contract will be / ~~will not~~ be subject to escalation in terms of the JBCC Contract Price Adjustment Provisions.

11. LOCAL LABOUR

The Tenderer's attention is specifically drawn to Clause 13, Section 1: Preliminaries (Section C) of these Bills of Quantities.

It is strongly recommended that the successful Contractor appoint a community facilitator in order to facilitate the requirements of Clause 13 of the Preliminaries (Section C).

It must be clearly understood that should a community facilitator be appointed; he will remain the full responsibility of the Contractor and no claims will be entertained in this respect.

12. EXPENSES IN PREPARATION OF TENDERS

The Employer will not be responsible for, or pay for, any expenses or losses incurred by the Tenderer during the preparation of his tender.



C2.2- Bills of Quantities

WILLIAM HUMPHREYS ART GALLERY : HVAC INSTALLATION

BILL OF QUANTITIES

HVAC INSTALLATION

SECTION 1 : PRELIMINARY AND GENERAL ITEMS

Item No	Description	Unit	Quantity	Rate	Amount R
1	PRELIMINARIES AND GENERAL				
	Note: All items shall be priced for whatever cost may be consider necessary for Preliminary and General to carry out the HVAC Installations in full for this phase of works, as detailed in the drawings, specifications and schedules, which shall include, but shall not be limited, to the following:				
1.1	Site establishment for this phase				
1.1.1	Allow for all costs which may be required in order to place the necessary facilities on site for safe storage and orderly management purposes for the duration of this section/phase	Sum	1		
1.1.2	Full time ,Accredited Technician, as Supervisor for the duration of the Contract, who shall have the delegated authority to receive instructions and make decisions regarding this Contract, shall take responsibility of all the works done under this section/phase.	Sum	1		
1.1.3	Meetings during this section/phase	Sum	1		
1.1.4	Complete set of co-ordinated workshop drawings for HVAC installation of the associated section. To be submitted to Engineer for approval prior to construction.	No	1		
1.1.5	Ablution and latrine facilities	Sum	1		
1.1.6	Water supplies, electric power & access	Sum	1		
1.1.7	Remove Contractor's site on completion	Sum	1		
1.1.8	Allow for project notice board	Sum	1		
1.1.9	Allow for submission and revisions of Works programme	Sum	1		
1.1.10	Allow for the required Surety of 10% of the Contract Amount	Sum	1		
1.1.11	Allow for compliance with all statutory requirements as specified	Sum	1		
1.1.12	Allow for phasing of works including works after business hours to ensure the building is safe an can be utilized during the day time.	Sum	1		
1.2	Completion and submission of Client commissioning data including the following for this section				
1.2.1	Factory acceptance testing of air handling units for this phase	Sum	1		
1.2.2	As built layout drawing	Sum	1		
1.2.3	Commissioning data	Sum	1		
1.2.4	Commissioning inspection and verification for this section/phase	Sum	1		
1.2.5	All associated COC's	Sum	1		
1.2.6	Allow for the submission of instruction manuals	Sum	1		
1.3	Labelling and painting				
1.3.1	Labelling of equipment as per specification	Sum	1		
1.4	Maintenance and instruction				
1.4.1	Instructing and training the Employer's staff in operation of system and equipment prior to hand over to the Client (2 hours)	No	1		
1.4.2	Provision of full maintenance of mechanical equipment and installation for the full 12 month period. The maintenance period shall start after practical completion for the associated section is achieved. Service sheets to be submitted for every service carried out. Refer to tender specification.	Sum	1		
1.4.3	Allow for supervision by accredited 3phase electrician	Sum	1		
1.5	Demolition and removal				
1.5.1	Provision for strip out and removal of redundant HVAC services and equipment in this section/phase	Sum	1		
1.5.2	Provision for strip out and removal of redundant chilled water piping reticulation in this section/phase	Sum	1		
1.5.3	Provision for making safe and strip out and removal of redundant electrical services and equipment in this section/phase	Sum	1		
1.5.4	Tenderer to allow for all costs associated with cleaning the site of all rubbish and waste caused in this section/phase of the Contract.	Sum	1		
1.6	Health and safety				
1.6.1	The Contractor shall, as a condition of the contract, ensue that the Site of the Works and the Works at all times comply with all relevant legislation , latest COVID19 regulations regarding health and safety of employees, as well as public legitimately on the Site or in the vicinity of the Site, while preventing unauthorized access to the Site of the Works. Contractor to list all items of health and safety included in the lump sum cost and provide the Employer with the aforementioned list at tender:	Sum	1		
1.6.2	Compliance to O.H.S. act including all site programmes, inductions, preparation of Health & Safety Plan, COVID 19 protocols, etc as per OHS specifications & applicable Government Gazette.	Sum	1		
1.6.3	Allow for the following insurances:	Sum	1		
a	Of the Works	Sum	1		
b	Public liability	Sum	1		
c	Plant and equipment	Sum	1		
d	Common law liability	Sum	1		
e	Any other insurance	Sum	1		
1.6.4	OSH Plan	Sum	1		
Total Carried Forward To Summary					

WILLIAM HUMPHREYS ART GALLERY : HVAC INSTALLATION

BILL OF QUANTITIES

HVAC INSTALLATION

SECTION 2 : PLANT ROOM 1 AND 2

2	AIR CONDITIONING INSTALLATION				
	Supply, delivery to site, installation and commissioning of the following complete hybrid DX air handling systems as specified in technical specification and as shown on the drawings. Items shall include all associated consumables.				
<hr/>					
2.1	AHU 1.1: 15.5 kW Nominal cooling capacity:				
2.1.1	Supply of air handling unit	No	1		
2.1.2	Assembly of air handling unit on site	No	1		
2.1.3	Steel support framework base for air handling unit	No	1		
2.1.4	Supply and installation of 10kg steam humidifier and associated controls	No	1		
2.1.5	Supply and installation of VRF condenser unit (similar or equal to LG)	No	1		
2.1.6	BluChem treatment of condenser unit	No	1		
2.1.7	Control cabling between indoor and condenser unit	No	1		
2.1.8	Electrical supply cable from air handling unit control panel to condensing unit	m	15		
2.1.9	Supply and installation of wall mounted wired temperature sensor connected to unit controls and BMS including associated wiring and conduits	No	1		
2.1.10	Supply and installation of wall mounted wired relative humidity sensor connected to unit controls and BMS including associated wiring and conduits	No	1		
2.1.11	Supply and installation of wall mounted wired CO2 sensor connected to unit controls and BMS including associated wiring and conduits	No	1		
2.1.12	Supply and installation of 32mm diameter UPVC condensate drainage for air handling and condenser units including brackets and all fittings.	m	15		
2.1.13	Commissioning of unit	No	1		
2.1.14	Connection of air handling unit to BMS	No	1		
2.1.15	Labelling of unit	No	1		
2.1.16	Refrigeration installation (15 meters refrigerant piping)	No	1		
2.1.17	Supply and installation of wire mesh basket for refrigerant support	No	1		
2.1.18	Connection of humidifier to water supply	No	1		
2.1.19	Supply and install galvanised trunking to cover exposed refrigeration piping with accessories as specified. Galvanised trunking to be painted same colour as the exterior of the building.	Sum	1		
2.1.20	Protection exposed final refrigeration piping connection to condenser unit with 2 coats PVA paint. Colour same as exterior of building.	Sum	1		
2.1.21	Supply and install constant volume supply air diffusers, epoxy powder coated complete with supports and accessories as scheduled and specified. Complete with insulated flexible ducting, secured with jubilee clamps at both ends				
a	Ø 400 Rickard type RCD	No	4		
b	Provision for removal of existing diffusers at height	No	4		
2.1.22	Supply and install outside air grille complete with opposed blade damper onto the air handling unit				
a	Size: 500 x 500 (fixed)	No	1		
a	Refrigeration installation (15 meters refrigerant piping)	No	2		
2.1.23	Supply and install air balancing dampers complete with fittings, fixings, supports and accessories.				
a	Size: 400 x 400	No	2		
2.1.24	Supply and install complete ducting installation associated with the unit. Galvanised Sheet Metal Ducting shall complete with FRK insulation and all necessary hangers, brackets and accessories as scheduled and specified. The ducting shall be sealed properly in the joints.				
a	Ducting installation	Sum	1		
2.1.25	Supply and install fusible link fire dampers				
a	Size: Ø 150	No	4		
b	Size: Ø 200	No	2		
c	Size: 1200 x 600	No	1		
<hr/>					
2.2	AHU 1.2: 21.1 kW Nominal cooling capacity:				
2.2.1	Supply of air handling unit	No	1		
2.2.2	Assembly of air handling unit on site	No	1		
2.2.3	Steel support framework base for air handling unit	No	1		
2.2.4	Supply and installation of 15kg steam humidifier and associated controls	No	1		
2.2.5	Supply and installation of VRF condenser unit (similar or equal to LG)	No	1		
2.2.6	BluChem treatment of condenser unit	No	1		
2.2.7	Control cabling between indoor and condenser unit	No	1		
2.2.8	Electrical supply cable from air handling unit control panel to condensing unit	m	15		
2.2.9	Supply and installation of wall mounted wired temperature sensor connected to unit controls and BMS including associated wiring and conduits	No	1		
2.2.10	Supply and installation of wall mounted wired relative humidity sensor connected to unit controls and BMS including associated wiring and conduits	No	1		
2.2.11	Supply and installation of wall mounted wired CO2 sensor connected to unit controls and BMS including associated wiring and conduits	No	1		
2.2.12	Supply and installation of 32mm diameter UPVC condensate drainage for air handling and condenser units including brackets and all fittings.	m	15		
2.2.13	Commissioning of unit	No	1		
2.2.14	Connection of air handling unit to BMS	No	1		
2.2.15	Labelling of unit	No	1		
2.2.16	Refrigeration installation (15 meters refrigerant piping)	No	1		
2.2.17	Supply and installation of wire mesh basket for refrigerant support	No	1		
2.2.18	Connection of humidifier to water supply	No	1		
<hr/>					
Total Carried Forward					

WILLIAM HUMPHREYS ART GALLERY : HVAC INSTALLATION

BILL OF QUANTITIES

HVAC INSTALLATION

SECTION 2 : PLANT ROOM 1 AND 2

2 AIR CONDITIONING INSTALLATION (cont.)		Total Brought Forward			
2.2.19	Supply and install galvanised trunking to cover exposed refrigeration piping with accessories as specified. Galvanised trunking to be painted same colour as the exterior of the building.	Sum	1		
2.2.20	Protection exposed final refrigeration piping connection to condenser unit with 2 coats PVA paint. Colour same as exterior of building.	Sum	1		
2.2.21	Supply and install constant volume supply air diffusers, epoxy powder coated complete with supports and accessories as scheduled and specified. Complete with insulated flexible ducting, secured with jubilee clamps at both ends				
a	Ø 400 Rickard type RCD	No	4		
b	Provision for removal of existing diffusers at height	No	4		
2.2.22	Supply and install outside air grille complete with opposed blade damper onto the air handling unit				
a	Size: 500 x 500 (fixed)	No	1		
a	Size: 500 x 500 (motorized and controlled by CO2 sensor)	No	2		
2.2.23	Supply and install air balancing dampers complete with fittings, fixings, supports and accessories.				
a	Size: 400 x 400	No	2		
2.2.24	Supply and install complete ducting installation associated with the unit. Galvanised Sheet Metal Ducting shall complete with FRK insulation and all necessary hangers, brackets and accessories as scheduled and specified. The ducting shall be sealed properly in the joints.				
a	Ducting installation	Sum	1		
2.2.25	Supply and install fusible link fire dampers				
a	Size: Ø 150	No	4		
b	Size: Ø 200	No	2		
c	Size: 1200 x 600	No	1		
2.3	AHU 2: 17.14 kW Nominal cooling capacity:				
2.3.1	Supply of air handling unit	No	1		
2.3.2	Assembly of air handling unit on site	No	1		
2.3.3	Steel support framework base for air handling unit	No	1		
2.3.4	Supply and installation of 15kg steam humidifier and associated controls	No	1		
2.3.5	Supply and installation of VRF condenser unit (similar or equal to LG)	No	1		
2.3.6	Bluchem treatment of condenser unit	No	1		
2.3.7	Control cabling between indoor and condenser unit	No	1		
2.3.8	Electrical supply cable from air handling unit control panel to condensing unit	m	15		
2.3.9	Supply and installation of wall mounted wired temperature sensor connected to unit controls and BMS including associated wiring and conduits	No	1		
2.3.10	Supply and installation of wall mounted wired relative humidity sensor connected to unit controls and BMS including associated wiring and conduits	No	1		
2.3.11	Supply and installation of wall mounted wired CO2 sensor connected to unit controls and BMS including associated wiring and conduits	No	1		
2.3.12	Supply and installation of 32mm diameter UPVC condensate drainage for air handling and condenser units including brackets and all fittings.	m	15		
2.3.13	Commissioning of unit	No	1		
2.3.14	Connection of air handling unit to BMS	No	1		
2.3.15	Labelling of unit	No	1		
2.3.16	Refrigeration installation (15 meters refrigerant piping)	No	1		
2.3.17	Supply and installation of wire mesh basket for refrigerant support	No	1		
2.3.18	Connection of humidifier to water supply	No	1		
2.3.19	Supply and install galvanised trunking to cover exposed refrigeration piping with accessories as specified. Galvanised trunking to be painted same colour as the exterior of the building.	Sum	1		
2.3.20	Protection exposed final refrigeration piping connection to condenser unit with 2 coats PVA paint. Colour same as exterior of building.	Sum	1		
2.3.21	Supply and install constant volume supply air diffusers, epoxy powder coated complete with supports and accessories as scheduled and specified. Complete with insulated flexible ducting, secured with jubilee clamps at both ends				
a	Ø 400 Rickard type RCD	No	4		
b	Provision for removal of existing diffusers at height	No	4		
2.3.22	Supply and install outside air grille complete with opposed blade damper onto the air handling unit				
a	Size: 500 x 500 (fixed)	No	1		
a	Size: 500 x 500 (motorized and controlled by CO2 sensor)	No	2		
2.3.23	Supply and install air balancing dampers complete with fittings, fixings, supports and accessories.				
a	Size: 400 x 400	No	2		
2.3.24	Supply and install complete ducting installation associated with the unit. Galvanised Sheet Metal Ducting shall complete with FRK insulation and all necessary hangers, brackets and accessories as scheduled and specified. The ducting shall be sealed properly in the joints.				
a	Ducting installation	Sum	1		
2.3.25	Supply and install fusible link fire dampers				
a	Size: Ø 150	No	4		
b	Size: Ø 200	No	2		
c	Size: 1200 x 600	No	1		
2.4	Any other item not specified in the bill. Please specify below:				
2.4.1					R -
2.4.2					
2.4.3					
Total Carried Forward To Summary					

WILLIAM HUMPHREYS ART GALLERY : HVAC INSTALLATION

BILL OF QUANTITIES

HVAC INSTALLATION

SECTION 2 : PLANT ROOM 1 AND 2

3	WATER STORAGE INSTALLATION				
	Supply and install vertical storage tank complete with inlet float valve, filtration and pressure pump and reticulation to supply air handling unit humidifiers				
3.1 Storage tank and auxiliaries					
3.1.1	Supply and installation 1000 lt vertical storage water tank	No	2		
3.1.2	Tank inlet float valve including tank coupler	No	2		
3.1.3	40mm tank coupler	No	2		
3.1.4	40mm UPVC tank overflow piping including support brackets and elbows	m	20		
3.1.5	40mm to 15mm inlet pipe reducer	No	4		
3.1.6	15mm diameter isolation ball valve	No	4		
3.2 Piping reticulation					
3.2.1	Supply and install 15mm diameter PEX-AL-PEX piping complete with support brackets and elbows	m	40		
3.2.2	15mm diameter isolation ball valve	No	4		
3.2.3	Supply and install 15mm diameter PEX-AL-PEX piping complete with support brackets and elbows	m	40		
3.2.3	Supply and install 15mm diameter PEX-AL-PEX piping complete with support brackets and elbows	m	40		
3.3 Pump and filtration					
3.3.1	Supply and install 0.37kW peripheral pump complete with pressure switch	No	2		
3.3.2	Electrical isolator and connection of pump	No	2		
3.3.3	Supply and install 20" two-stage filter housing complete with 5 micron melted spray sediment filter and activated carbon block filter	No	2		
3.3.4	Supply and install 20" single-stage filter housing complete with 2 micron melted spray sediment filter	No	2		
Total Carried Forward To Summary					

WILLIAM HUMPHREYS ART GALLERY : HVAC INSTALLATION

BILL OF QUANTITIES

HVAC INSTALLATION

SECTION 2 : PLANT ROOM 1 AND 2

4	ELECTRICAL INSTALLATION				
The Supply and installation of LV Distribution Boards complete with equipment, busbars and switchgear as specified:					
4.1	New - DB AHU1&2 DB shall be conforming to the following specification and be fitted the equipment: a)Surface mounted,1.6mm thick steel ,epoxy powder coated. b.IP65 rated (Dust and Water proof) c.2 x Doors , handles , catches & locks d.Removable front panels e.1 x 250A,3Phase,25KA Circuit Breaker f.2 x 20A,3Phase,10KA Circuit Breaker g.8 x 30A,3Phase,10KA Circuit Breaker h.2 x 20A,1Phase,6KA Circuit Breaker h. Busbar rating 600A	No	2		
4.2	Strip and remove existing distribution board and safe making of circuits in plant room.	No	2		
4.3	Supply and Installation of 600/1000V PVC SWA cables on cable racks.				
4.3.1	35mm ² x 4 Core				
a	Supply	m	20		
b	Install	m	20		
4.3.2	6mm ² x 4 Core				
a	Supply	m	20		
b	Install	m	20		
4.4	Making off ends of 600/1000V PVC SWA cables onto switchgear and busbars,including all necessary cable end material,glands and cable clamps complete: 35mm ² x 4				
4.4.1	35mm ² x 4 Core				
a	Supply	No	4		
b	Install	No	4		
4.4.2	6mm ² x 4 Core				
a	Supply	No	20		
b	Install	No	20		
4.5	Supply and install 30A rotary IP 65 isolators .	No	10		
4.6	Marking/labelling of individual switch socket outlets and switches complete.	Sum	1		
4.7	Marking/labelling of individual main supply cables complete as per drawings.	Sum	1		
4.8	Testing , commissioning and issuing COC's for all Distribution(New & Existing) boards complete.	No	1		
Total Carried Forward To Summary					

WILLIAM HUMPHREYS ART GALLERY : HVAC INSTALLATION

BILL OF QUANTITIES

HVAC INSTALLATION

SECTION 3 : PLANT ROOMS 3 AND 4

Item No	Description	Unit	Quantity	Rate	Amount R
2	AIR CONDITIONING INSTALLATION				
	Supply, delivery to site, installation and commissioning of the following complete hybrid DX air handling systems as specified in technical specification and as shown on the drawings. Items shall include all associated consumables.				
2.1	AHU 3.1: 15.5 kW Nominal cooling capacity:				
2.1.1	Supply of air handling unit	No	1		
2.1.2	Assembly of air handling unit on site	No	1		
2.1.3	Steel support framework base for air handling unit	No	1		
2.1.4	Supply and installation of 10kg steam humidifier and associated controls	No	1		
2.1.5	Supply and installation of VRF condenser unit (similar or equal to LG)	No	1		
2.1.6	Bluchem treatment of condenser unit	No	1		
2.1.7	Control cabling between indoor and condenser unit	No	1		
2.1.8	Electrical supply cable from air handling unit control panel to condensing unit	m	15		
2.1.9	Supply and installation of wall mounted wired temperature sensor connected to unit controls and BMS including associated wiring and conduits	No	1		
2.1.10	Supply and installation of wall mounted wired relative humidity sensor connected to unit controls and BMS including associated wiring and conduits	No	1		
2.1.11	Supply and installation of wall mounted wired CO2 sensor connected to unit controls and BMS including associated wiring and conduits	No	1		
2.1.12	Supply and installation of 32mm diameter UPVC condensate drainage for air handling and condenser units including brackets and all fittings.	m	15		
2.1.13	Commissioning of unit	No	1		
2.1.14	Connection of air handling unit to BMS	No	1		
2.1.15	Labelling of unit	No	1		
2.1.16	Refrigeration installation (15 meters refrigerant piping)	No	1		
2.1.17	Supply and installation of wire mesh basket for refrigerant support	No	1		
2.1.18	Connection of humidifier to water supply	No	1		
2.1.19	Supply and install galvanised trunking to cover exposed refrigeration piping with accessories as specified. Galvanised trunking to be painted same colour as the exterior of the building.	Sum	1		
2.1.20	Protection exposed final refrigeration piping connection to condenser unit with 2 coats PVA paint. Colour same as exterior of building.	Sum	1		
2.1.21	Supply and install constant volume supply air diffusers, epoxy powder coated complete with supports and accessories as scheduled and specified. Complete with insulated flexible ducting, secured with jubilee clamps at both ends				
a	Ø 400 Rickard type RCD	No	4		
b	Provision for removal of existing diffusers at height	No	4		
2.1.22	Supply and install outside air grille complete with opposed blade damper onto the air handling unit				
a	Size: 500 x 500 (fixed)	No	1		
a	Size: 500 x 500 (motorized and controlled by CO2 sensor)	No	2		
2.1.23	Supply and install air balancing dampers complete with fittings, fixings, supports and accessories.				
a	Size: 400 x 400	No	2		
2.1.24	Supply and install complete ducting installation associated with the unit. Galvanised Sheet Metal Ducting shall complete with FRK insulation and all necessary hangers, brackets and accessories as scheduled and specified. The ducting shall be sealed properly in the joints.				
a	Ducting installation	Sum	1		
2.1.25	Supply and install fusible link fire dampers				
a	Size: Ø 150	No	4		
b	Size: Ø 200	No	2		
c	Size: 1200 x 600	No	1		
2.2	AHU 3.2: 20.7 kW Nominal cooling capacity:				
2.2.1	Supply of air handling unit	No	1		
2.2.2	Assembly of air handling unit on site	No	1		
2.2.3	Steel support framework base for air handling unit	No	1		
2.2.4	Supply and installation of 15kg steam humidifier and associated controls	No	1		
2.2.5	Supply and installation of VRF condenser unit (similar or equal to LG)	No	1		
2.2.6	Bluchem treatment of condenser unit	No	1		
2.2.7	Control cabling between indoor and condenser unit	No	1		
2.2.8	Electrical supply cable from air handling unit control panel to condensing unit	m	15		
2.2.9	Supply and installation of wall mounted wired temperature sensor connected to unit controls and BMS including associated wiring and conduits	No	1		
2.2.10	Supply and installation of wall mounted wired relative humidity sensor connected to unit controls and BMS including associated wiring and conduits	No	1		
2.2.11	Supply and installation of wall mounted wired CO2 sensor connected to unit controls and BMS including associated wiring and conduits	No	1		
2.2.12	Supply and installation of 32mm diameter UPVC condensate drainage for air handling and condenser units including brackets and all fittings.	m	15		
2.2.13	Commissioning of unit	No	1		
2.2.14	Connection of air handling unit to BMS	No	1		
2.2.15	Labelling of unit	No	1		
2.2.16	Refrigeration installation (15 meters refrigerant piping)	No	1		
2.2.17	Supply and installation of wire mesh basket for refrigerant support	No	1		
2.2.18	Connection of humidifier to water supply	No	1		
Total Carried Forward					

WILLIAM HUMPHREYS ART GALLERY : HVAC INSTALLATION

BILL OF QUANTITIES

HVAC INSTALLATION

SECTION 3 : PLANT ROOMS 3 AND 4

Item No	Description	Unit	Quantity	Rate	Amount R
2	AIR CONDITIONING INSTALLATION (cont.)				
			Total Brought Forward		
2.2.19	Supply and install galvanised trunking to cover exposed refrigeration piping with accessories as specified. Galvanised trunking to be painted same colour as the exterior of the building.	Sum	1		
2.2.20	Protection exposed final refrigeration piping connection to condenser unit with 2 coats PVA paint. Colour same as exterior of building.	Sum	1		
2.2.21	Supply and install constant volume supply air diffusers, epoxy powder coated complete with supports and accessories as scheduled and specified. Complete with insulated flexible ducting, secured with jubilee clamps at both ends				
a	Ø 400 Rickard type RCD	No	4		
b	Provision for removal of existing diffusers at height	No	4		
2.2.22	Supply and install outside air grille complete with opposed blade damper onto the air handling unit				
a	Size: 500 x 500 (fixed)	No	1		
a	Size: 500 x 500 (motorized and controlled by CO2 sensor)	No	2		
2.2.23	Supply and install air balancing dampers complete with fittings, fixings, supports and accessories.				
a	Size: 400 x 400	No	2		
2.2.24	Supply and install complete ducting installation associated with the unit. Galvanised Sheet Metal Ducting shall complete with FRK insulation and all necessary hangers, brackets and accessories as scheduled and specified. The ducting shall be sealed properly in the joints.				
a	Ducting installation	Sum	1		
2.2.25	Supply and install fusible link fire dampers				
a	Size: Ø 150	No	4		
b	Size: Ø 200	No	2		
c	Size: 1200 x 600	No	1		
2.3	AHU 4.1: 27.2 kW Nominal cooling capacity:				
2.3.1	Supply of air handling unit	No	1		
2.3.2	Assembly of air handling unit on site	No	1		
2.3.3	Steel support framework base for air handling unit	No	1		
2.3.4	Supply and installation of 18kg steam humidifier and associated controls	No	1		
2.3.5	Supply and installation of VRF condenser unit (similar or equal to LG)	No	1		
2.3.6	Bluchem treatment of condenser unit	No	1		
2.3.7	Control cabling between indoor and condenser unit	No	1		
2.3.8	Electrical supply cable from air handling unit control panel to condensing unit	m	15		
2.3.9	Supply and installation of wall mounted wired temperature sensor connected to unit controls and BMS including associated wiring and conduits	No	1		
2.3.10	Supply and installation of wall mounted wired relative humidity sensor connected to unit controls and BMS including associated wiring and conduits	No	1		
2.3.11	Supply and installation of wall mounted wired CO2 sensor connected to unit controls and BMS including associated wiring and conduits	No	1		
2.3.12	Supply and installation of 32mm diameter UPVC condensate drainage for air handling and condenser units including brackets and all fittings.	m	15		
2.3.13	Commissioning of unit	No	1		
2.3.14	Connection of air handling unit to BMS	No	1		
2.3.15	Labelling of unit	No	1		
2.3.16	Refrigeration installation (15 meters refrigerant piping)	No	1		
2.3.17	Supply and installation of wire mesh basket for refrigerant support	No	1		
2.3.18	Connection of humidifier to water supply	No	1		
2.3.19	Supply and install galvanised trunking to cover exposed refrigeration piping with accessories as specified. Galvanised trunking to be painted same colour as the exterior of the building.	Sum	1		
2.3.20	Protection exposed final refrigeration piping connection to condenser unit with 2 coats PVA paint. Colour same as exterior of building.	Sum	1		
2.3.21	Supply and install constant volume supply air diffusers, epoxy powder coated complete with supports and accessories as scheduled and specified. Complete with insulated flexible ducting, secured with jubilee clamps at both ends				
a	Ø 400 Rickard type RCD	No	4		
b	Provision for removal of existing diffusers at height	No	4		
2.3.22	Supply and install outside air grille complete with opposed blade damper onto the air handling unit				
a	Size: 500 x 500 (fixed)	No	1		
a	Size: 500 x 500 (motorized and controlled by CO2 sensor)	No	2		
2.3.23	Supply and install air balancing dampers complete with fittings, fixings, supports and accessories.				
a	Size: 400 x 400	No	2		
2.3.24	Supply and install complete ducting installation associated with the unit. Galvanised Sheet Metal Ducting shall complete with FRK insulation and all necessary hangers, brackets and accessories as scheduled and specified. The ducting shall be sealed properly in the joints.				
a	Ducting installation	Sum	1		
2.3.25	Supply and install fusible link fire dampers				
a	Size: Ø 150	No	4		
b	Size: Ø 200	No	2		
c	Size: 1200 x 600	No	1		
2.4	AHU 4.2: 12.03 kW Nominal cooling capacity:				
2.4.1	Supply of air handling unit	No	1		
2.4.2	Assembly of air handling unit on site	No	1		
2.4.3	Steel support framework base for air handling unit	No	1		
			Total Carried Forward		

WILLIAM HUMPHREYS ART GALLERY : HVAC INSTALLATION

BILL OF QUANTITIES

HVAC INSTALLATION

SECTION 3 : PLANT ROOMS 3 AND 4

Item No	Description	Unit	Quantity	Rate	Amount R
2	AIR CONDITIONING INSTALLATION (cont.)				
			Total Brought Forward		
2.4.4	Supply and installation of 10kg steam humidifier and associated controls	No	1		
2.4.5	Supply and installation of VRF condenser unit (similar or equal to LG)	No	1		
2.4.6	Bluchem treatment of condenser unit	No	1		
2.4.7	Control cabling between indoor and condenser unit	No	1		
2.4.8	Electrical supply cable from air handling unit control panel to condensing unit	m	15		
2.4.9	Supply and installation of wall mounted wired temperature sensor connected to unit controls and BMS including associated wiring and conduits	No	1		
2.4.10	Supply and installation of wall mounted wired relative humidity sensor connected to unit controls and BMS including associated wiring and conduits	No	1		
2.4.11	Supply and installation of wall mounted wired CO2 sensor connected to unit controls and BMS including associated wiring and conduits	No	1		
2.4.12	Supply and installation of 32mm diameter UPVC condensate drainage for air handling and condenser units including brackets and all fittings.	m	15		
2.4.13	Commissioning of unit	No	1		
2.4.14	Connection of air handling unit to BMS	No	1		
2.4.15	Labelling of unit	No	1		
2.4.16	Refrigeration installation (15 meters refrigerant piping)	No	1		
2.4.17	Supply and installation of wire mesh basket for refrigerant support	No	1		
2.4.18	Connection of humidifier to water supply	No	1		
2.4.19	Supply and install galvanised trunking to cover exposed refrigeration piping with accessories as specified. Galvanised trunking to be painted same colour as the exterior of the building.	Sum	1		
2.4.20	Protection exposed final refrigeration piping connection to condenser unit with 2 coats PVA paint. Colour same as exterior of building.	Sum	1		
2.4.21	Supply and install constant volume supply air diffusers, epoxy powder coated complete with supports and accessories as scheduled and specified. Complete with insulated flexible ducting, secured with jubilee clamps at both ends				
a	Ø 400 Rickard type RCD	No	4		
b	Provision for removal of existing diffusers at height	No	4		
2.4.22	Supply and install outside air grille complete with opposed blade damper onto the air handling unit				
a	Size: 500 x 500 (fixed)	No	1		
a	Size: 500 x 500 (motorized and controlled by CO2 sensor)	No	2		
2.4.23	Supply and install air balancing dampers complete with fittings, fixings, supports and accessories.				
a	Size: 400 x 400	No	2		
2.4.24	Supply and install complete ducting installation associated with the unit. Galvanised Sheet Metal Ducting shall complete with FRK insulation and all necessary hangers, brackets and accessories as scheduled and specified. The ducting shall be sealed properly in the joints.				
a	Ducting installation	Sum	1		
2.4.25	Supply and install fusible link fire dampers				
a	Size: Ø 150	No	4		
b	Size: Ø 200	No	2		
c	Size: 1200 x 600	No	1		
2.5	AHU 4.3: 15.32 kW Nominal cooling capacity:				
2.5.1	Supply of air handling unit	No	1		
2.5.2	Assembly of air handling unit on site	No	1		
2.5.3	Steel support framework base for air handling unit	No	1		
2.5.4	Supply and installation of 15kg steam humidifier and associated controls	No	1		
2.5.5	Supply and installation of VRF condenser unit (similar or equal to LG)	No	1		
2.5.6	Bluchem treatment of condenser unit	No	1		
2.5.7	Control cabling between indoor and condenser unit	No	1		
2.5.8	Electrical supply cable from air handling unit control panel to condensing unit	m	15		
2.5.9	Supply and installation of wall mounted wired temperature sensor connected to unit controls and BMS including associated wiring and conduits	No	1		
2.5.10	Supply and installation of wall mounted wired relative humidity sensor connected to unit controls and BMS including associated wiring and conduits	No	1		
2.5.11	Supply and installation of wall mounted wired CO2 sensor connected to unit controls and BMS including associated wiring and conduits	No	1		
2.5.12	Supply and installation of 32mm diameter UPVC condensate drainage for air handling and condenser units including brackets and all fittings.	m	15		
2.5.13	Commissioning of unit	No	1		
2.5.14	Connection of air handling unit to BMS	No	1		
2.5.15	Labelling of unit	No	1		
2.5.16	Refrigeration installation (15 meters refrigerant piping)	No	1		
2.5.17	Supply and installation of wire mesh basket for refrigerant support	No	1		
2.5.18	Connection of humidifier to water supply	No	1		
2.5.19	Supply and install galvanised trunking to cover exposed refrigeration piping with accessories as specified. Galvanised trunking to be painted same colour as the exterior of the building.	Sum	1		
2.5.20	Protection exposed final refrigeration piping connection to condenser unit with 2 coats PVA paint. Colour same as exterior of building.	Sum	1		
			Total Carried Forward		

WILLIAM HUMPHREYS ART GALLERY : HVAC INSTALLATION

BILL OF QUANTITIES

HVAC INSTALLATION

SECTION 3 : PLANT ROOMS 3 AND 4

Item No	Description	Unit	Quantity	Rate	Amount R
2	AIR CONDITIONING INSTALLATION (cont.)				
Total Brought Forward					
2.5.21	Supply and install constant volume supply air diffusers, epoxy powder coated complete with supports and accessories as scheduled and specified. Complete with insulated flexible ducting, secured with jubilee clamps at both ends				
a	Ø 400 Rickard type RCD	No	4		
b	Provision for removal of existing diffusers at height	No	4		
2.5.22	Supply and install outside air grille complete with opposed blade damper onto the air handling unit				
a	Size: 500 x 500 (fixed)	No	1		
a	Size: 500 x 500 (motorized and controlled by CO2 sensor)	No	2		
2.5.23	Supply and install air balancing dampers complete with fittings, fixings, supports and accessories.				
a	Size: 400 x 400	No	2		
2.5.24	Supply and install complete ducting installation associated with the unit. Galvanised Sheet Metal Ducting shall complete with FRK insulation and all necessary hangers, brackets and accessories as scheduled and specified. The ducting shall be sealed properly in the joints.				
a	Ducting installation	Sum	1		
2.5.25	Supply and install fusible link fire dampers				
a	Size: Ø 150	No	4		
b	Size: Ø 200	No	2		
c	Size: 1200 x 600	No	1		
2.6	<u>Any other item not specified in the bill. Please specify below:</u>				
2.6.1					R -
2.6.2					
2.6.3					
Total Carried Forward To Summary					

WILLIAM HUMPHREYS ART GALLERY : HVAC INSTALLATION**BILL OF QUANTITIES****HVAC INSTALLATION****SECTION 3 : PLANT ROOMS 3 AND 4**

Item No	Description	Unit	Quantity	Rate	Amount R
3	WATER STORAGE INSTALLATION				
	Supply and install vertical storage tank complete with inlet float valve, filtration and pressure pump and reticulation to supply air handling unit humidifiers				
3.1	<u>Storage tank and auxiliaries</u>				
3.1.1	Supply and installation 1000 lt vertical storage water tank	No	2		
3.1.2	Tank inlet float valve including tank coupler	No	2		
3.1.3	40mm tank coupler	No	2		
3.1.4	40mm UPVC tank overflow piping including support brackets and elbows	m	20		
3.1.5	40mm to 15mm inlet pipe reducer	No	4		
3.1.6	15mm diameter isolation ball valve	No	4		
3.2	<u>Piping reticulation</u>				
3.2.1	Supply and install 15mm diameter PEX-AL-PEX piping complete with support brackets and elbows	m	40		
3.2.2	15mm diameter isolation ball valve	No	4		
3.2.3	Supply and install 15mm diameter PEX-AL-PEX piping complete with support brackets and elbows	m	40		
3.2.3	Supply and install 15mm diameter PEX-AL-PEX piping complete with support brackets and elbows	m	40		
3.3	<u>Pump and filtration</u>				
3.3.1	Supply and install 0.37kW peripheral pump complete with pressure switch	No	2		
3.3.2	Electrical isolator and connection of pump	No	2		
3.3.3	Supply and install 20" two-stage filter housing complete with 5 micron melted spray sediment filter and activated carbon block filter	No	2		
3.3.4	Supply and install 20" single-stage filter housing complete with 2 micron melted spray sediment filter	No	2		
Total Carried Forward To Summary					

WILLIAM HUMPHREYS ART GALLERY : HVAC INSTALLATION**BILL OF QUANTITIES****HVAC INSTALLATION****SECTION 3 : PLANT ROOMS 3 AND 4**

Item No	Description	Unit	Quantity	Rate	Amount R
4	ELECTRICAL INSTALLATION				
	The Supply and installation of LV Distribution Boards complete with equipment, busbars and switchgear as specified:				
4.1	New - DB AHU3&4 DB shall be conforming to the following specification and be fitted the equipment: a.Surface mounted,1.6mm thick steel ,epoxy powder coated. b.IP65 rated (Dust and Water proof) c.2 x Doors , handles , catches & locks d.Removable front panels e.1 x 250A,3Phase,25KA Circuit Breaker f.2 x 20A,3Phase,10KA Circuit Breaker g.8 x 30A,3Phase,10KA Circuit Breaker h.2 x 20A,1Phase,6KA Circuit Breaker i. Busbar rating 600A i. 40% spare space	No	2		
4.2	Strip and remove existing distribution board and safe making of circuits in plant room.	No	2		
4.3	Supply and Installation of 600/1000V PVC SWA cables on cable racks.				
4.3.1	35mm ² x 4 Core				
a	Supply	m	20		
b	Install	m	20		
4.3.2	6mm ² x 4 Core				
a	Supply	m	20		
b	Install	m	20		
4.4	Making off ends of 600/1000V PVC SWA cables onto switchgear and busbars,including all necessary cable end material,glands and cable clamps complete: 35mm ² x 4				
4.4.1	35mm ² x 4 Core				
a	Supply	No	4		
b	Install	No	4		
4.4.2	6mm ² x 4 Core				
a	Supply	No	20		
b	Install	No	20		
4.5	Supply and install 30A rotary IP 65 isolators .	No	10		
4.6	Marking/labelling of individual switch socket outlets and switches complete.	Sum	1		
4.7	Marking/labelling of individual main supply cables complete as per drawings.	Sum	1		
4.8	Testing , commissioning and issuing COC's for all Distribution(New & Existing) boards complete.	No	1		
Total Carried Forward To Summary					

WILLIAM HUMPHREYS ART GALLERY : HVAC INSTALLATION

BILL OF QUANTITIES

HVAC INSTALLATION

SECTION 4: - PLANT ROOMS 5

Item No	Description	Unit	Quantity	Rate	Amount R
Total Carried Forward To Summary					
2	AIR CONDITIONING INSTALLATION				
	Supply, delivery to site, installation and commissioning of the following complete hybrid DX air handling systems as specified in technical specification and as shown on the drawings. Items shall include all associated consumables.				
2.1	AHU 5: 12.3 kW Nominal cooling capacity:				
2.1.1	Supply of air handling unit	No	1		
2.1.2	Assembly of air handling unit on site	No	1		
2.1.3	Steel support framework base for air handling unit	No	1		
2.1.4	Supply and installation of 10kg steam humidifier and associated controls	No	1		
2.1.5	Supply and installation of VRF condenser unit (similar or equal to LG)	No	1		
2.1.6	Bluchem treatment of condenser unit	No	1		
2.1.7	Control cabling between indoor and condenser unit	No	1		
2.1.8	Electrical supply cable from air handling unit control panel to condensing unit	m	15		
2.1.9	Supply and installation of wall mounted wired temperature sensor connected to unit controls and BMS including associated wiring and conduits	No	1		
2.1.10	Supply and installation of wall mounted wired relative humidity sensor connected to unit controls and BMS including associated wiring and conduits	No	1		
2.1.11	Supply and installation of wall mounted wired CO2 sensor connected to unit controls and BMS including associated wiring and conduits	No	1		
2.1.12	Supply and installation of 32mm diameter UPVC condensate drainage for air handling and condenser units including brackets and all fittings.	m	15		
2.1.13	Commissioning of unit	No	1		
2.1.14	Connection of air handling unit to BMS	No	1		
2.1.15	Labelling of unit	No	1		
2.1.16	Refrigeration installation (15 meters refrigerant piping)	No	1		
2.1.17	Supply and installation of wire mesh basket for refrigerant support	No	1		
2.1.18	Connection of humidifier to water supply	No	1		
2.1.19	Supply and install galvanised trunking to cover exposed refrigeration piping with accessories as specified. Galvanised trunking to be painted same colour as the exterior of the building.	Sum	1		
2.1.20	Protection exposed final refrigeration piping connection to condenser unit with 2 coats PVA paint. Colour same as exterior of building.	Sum	1		
2.1.21	Supply and install constant volume supply air diffusers, epoxy powder coated complete with supports and accessories as scheduled and specified. Complete with insulated flexible ducting, secured with jubilee clamps at both ends				
a	Ø 400 Rickard type RCD	No	4		
b	Provision for removal of existing diffusers at height	No	4		
2.1.22	Supply and install outside air grille complete with opposed blade damper onto the air handling unit				
a	Size: 500 x 500 (fixed)	No	1		
a	Size: 500 x 500 (motorized and controlled by CO2 sensor)	No	2		
2.1.23	Supply and install air balancing dampers complete with fittings, fixings, supports and accessories.				
a	Size: 400 x 400	No	2		
2.1.24	Supply and install complete ducting installation associated with the unit. Galvanised Sheet Metal Ducting shall complete with FRK insulation and all necessary hangers, brackets and accessories as scheduled and specified. The ducting shall be sealed properly in the joints.				
a	Ducting installation	Sum	1		
2.1.25	Supply and install fusible link fire dampers				
a	Size: Ø 150	No	4		
b	Size: Ø 200	No	2		
c	Size: 1200 x 600	No	1		
2.2	Air handling unit screening				
2.2.1	Supply and install of galvanized steel frame complete with gate around condenser unit and storage tank	No	1		
2.2.2	Cladding of frame with nutec	No	1		
2.2.3	Painting of frame and nutec to match existing external wall colour	No	1		
2.2.4	Provision of 600x600 concrete pavers below condenser unit	No	9		
2.2.5	Levelling and compaction of soil below concrete pavers	Sum	1		
2.3	Any other item not specified in the bill. Please specify below:				
2.3.1					
2.3.2					
2.3.3					
Total Carried Forward To Summary					

WILLIAM HUMPHREYS ART GALLERY : HVAC INSTALLATION

BILL OF QUANTITIES

HVAC INSTALLATION

SECTION 4: - PLANT ROOMS 5

Item No	Description	Unit	Quantity	Rate	Amount R
3	WATER STORAGE INSTALLATION				
	Supply and install vertical storage tank complete with inlet float valve, filtration and pressure pump and reticulation to supply air handling unit humidifiers				
3.1	<u>Storage tank and auxiliaries</u>				
3.1.1	Supply and installation 1000 lt vertical storage water tank	No	2		
3.1.2	Tank inlet float valve including tank coupler	No	2		
3.1.3	40mm tank coupler	No	2		
3.1.4	40mm UPVC tank overflow piping including support brackets and elbows	m	20		
3.1.5	40mm to 15mm inlet pipe reducer	No	4		
3.1.6	15mm diameter isolation ball valve	No	4		
3.2	<u>Piping reticulation</u>				
3.2.1	Supply and install 15mm diameter PEX-AL-PEX piping complete with support brackets and elbows	m	40		
3.2.2	15mm diameter isolation ball valve	No	4		
3.2.3	Supply and install 15mm diameter PEX-AL-PEX piping complete with support brackets and elbows	m	40		
3.2.3	Supply and install 15mm diameter PEX-AL-PEX piping complete with support brackets and elbows	m	40		
3.3	<u>Pump and filtration</u>				
3.3.1	Supply and install 0.37kW peripheral pump complete with pressure switch	No	2		
3.3.2	Electrical isolator and connection of pump	No	2		
3.3.3	Supply and install 20" two-stage filter housing complete with 5 micron melted spray sediment filter and activated carbon block filter	No	2		
3.3.4	Supply and install 20" single-stage filter housing complete with 2 micron melted spray sediment filter	No	2		
Total Carried Forward To Summary					

WILLIAM HUMPHREYS ART GALLERY : HVAC INSTALLATION

BILL OF QUANTITIES

HVAC INSTALLATION

SECTION 4: - PLANT ROOMS 5

Item No	Description	Unit	Quantity	Rate	Amount R
4	ELECTRICAL INSTALLATION				
	The Supply and installation of LV Distribution Boards complete with equipment, busbars and switchgear as specified:				
4.1	New - DB AHU5 DB shall be conforming to the following specification and be fitted the equipment: a)Surface mounted,1.6mm thick steel ,epoxy powder coated. b.IP65 rated (Dust and Water proof) c.2 x Doors , handles , catches & locks d.Removable front panels e.1 x 250A,3Phase,25KA Circuit Breaker f.2 x 20A,3Phase,10KA Circuit Breaker g.8 x 30A,3Phase,10KA Circuit Breaker h.2 x 20A,1Phase,6KA Circuit Breaker i. Busbar rating 600A i. 40% spare space	No	2		
4.2	Strip and remove existing distribution board and safe making of circuits in plant room.	No	2		
4.3	Supply and Installation of 600/1000V PVC SWA cables on cable racks.				
4.3.1	35mm ² x 4 Core				
a	Supply	m	20		
b	Install	m	20		
4.3.2	6mm ² x 4 Core				
a	Supply	m	20		
b	Install	m	20		
4.4	Making off ends of 600/1000V PVC SWA cables onto switchgear and busbars,including all necessary cable end material,glands and cable clamps complete: 35mm ² x 4				
4.4.1	35mm ² x 4 Core				
a	Supply	No	4		
b	Install	No	4		
4.4.2	6mm ² x 4 Core				
a	Supply	No	20		
b	Install	No	20		
4.5	Supply and install 30A rotary IP 65 isolators .	No	10		
4.6	Marking/labelling of individual switch socket outlets and switches complete.	Sum	1		
4.7	Marking/labelling of individual main supply cables complete as per drawings.	Sum	1		
4.8	Testing , commissioning and issuing COC's for all Distribution(New & Existing) boards complete.	No	1		
Total Carried Forward To Summary					

WILLIAM HUMPHREYS ART GALLERY : HVAC INSTALLATION
BILL OF QUANTITIES

HVAC INSTALLATION
SECTION 5 : BMS

Item No	Description	Unit	Quantity	Rate	Amount R
1	BUILDING MANAGEMENT SYSTEM INSTALLATION				
	Note: All items shall be priced for whatever cost may be consider necessary for Preliminary and General to carry out the HVAC Installations in full for this phase of works, as detailed in the drawings, specifications and schedules, which shall include, but shall not be limited, to the following:				
1.1	BMS				
1.1.1	Supply and installation of front end PC	No	1		
1.1.2	Supply and installation of 3000VA offline UPS	No	1		
1.1.3	Wireless Network connection to PC	No	1		
1.1.4	Electrical connection and multiplug for PC power supply	PC	1	R 7 500.00	R 7 500.00
1.1.5	Johnson controls BMS	Sum	1		
1.1.6	Programming of BMS including graphical display front end	Sum	1		
1.1.7	Control cabling installation	Sum	1		
1.1.8	Supply and installation of the following sensors				
a	Wall mounted RH sensor	No	9		
b	Duct mounted temperature sensor	No	27		
c	Wal mounted CO2 sensor	No	9		
d	Pressure sensor	No	36		
1.1.9	Connection of the following equipment				
a	Air handling unit	No	9		
b	Humidifier	No	9		
c	Motorized control damper	No	9		
1.2	Any other item not specified in the bill. Please specify below:				
1.2.1					
1.2.2					
1.2.3					
Total Carried Forward To Summary					

**WILLIAM HUMPHREYS ART GALLERY : HVAC INSTALLATION
BILL OF QUANTITIES**

Date 19 03 2024

SECTIONS : SUMMARY OF PRICES

Rev 0

Item	Description	Total
1	SECTION 1 : PRELIMINARY AND GENERAL ITEMS	
2	SECTION 2 : PLANT ROOM 1 AND 2	
3	SECTION 3 : PLANT ROOMS 3 AND 4	
4	SECTION 4: - PLANT ROOMS 5	
5	SECTION 5 : BMS	
	Subtotal - 1	
	10% Contingency	
	Subtotal - 2	
	VAT @ 15%	
	Total Contract Price	



PART C3: SCOPE OF WORKS



DEPARTMENT OF SPORTS ARTS AND CULTURE:

WILLIAM HUMPREYS ART GALLERY – REPLACEMENT OF HVAC SYSTEMS

35129.00

TECHNICAL SPECIFICATION AND BILL OF QUANTITIES

FEBRUARY 2023

PREPARED FOR:



William Humphreys Art Gallery
1 Cullinan Crescent
Civic Centre
Kimberley
8301

PREPARED BY:



BVi Consulting Engineers WC (Pty) Ltd
Edison Square C/o Edison Way and
Century Avenue
Century City
7441

PART ONE

GENERAL TECHNICAL SPECIFICATION

FOR

AIR CONDITIONING INSTALLATIONS

CONSULTING ENGINEERS
BVi CONSULTING ENGINEERS (PTY) LTD
P O Box 86, CENTURY CITY 7446
Telephone: (021) 527-7000 CAPE TOWN
alfredom@bviwc.co.za

REFERENCE IV-01

PART ONE

GENERAL TECHNICAL SPECIFICATION FOR AIR CONDITIONING INSTALLATIONS

<u>CLAUSE</u>		<u>PAGE NUMBER</u>
	Index	1
1.1	Scope	2
1.2	General	2
1.3	Packaged Air Conditioning Units - Air Cooled and Evaporative Condenser Cooled	6
1.4	Refrigeration Pipework	6
1.5	Refrigeration Charge	7
1.6	Ductwork	8
1.7	Ductwork Insulation	10
1.8	Diffusers, Grilles and Louvres	11
1.9	Dampers	12
1.10	Sound Attenuators	13
1.11	Air Filters	14
1.12	Electric Motors	15
1.13	Electrode Humidifiers	16
1.14	Automatic Controls	17
1.15	Switchpanels and Control Boards	19
1.16	Electric Wiring	24
1.17	Instruments	26
1.18	Equipment Bases	27
1.19	Equipment Supports	29
1.20	Noise and Vibration	30
1.21	Painting and Cleaning	31
1.22	Labelling and Identification	33
1.23	Commissioning and Testing	34
1.24	Operating and Maintenance Instructions	37
1.25	Maintenance	39
1.26	Drains	40
1.27	Exclusions	41

1.1 **SCOPE**

- 1.1.1 This General Specification describes the usual material required for Air Conditioning installations and the general methods of constructing and installing the various components and equipment associated therewith.
- 1.1.2 This General Specification forms a supplement to the drawings and specifications for a particular subcontract. Where the detailed Specification of Part 2 and/or the drawings differ from this General Specification, the Detailed Specification and Drawings shall take precedence.

1.2 **GENERAL**

- 1.2.1 All workmanship and materials used in the installation shall be of the highest quality and, where not fully covered by this Specification, shall conform with best modern practice, as determined by the Engineer.
- 1.2.2 The entire installation shall comply fully with all relevant requirements of governmental and local authorities and the equipment provided for the installation shall comply in all respects with the Occupational Health and Safety Act of 1993 as amended.
- 1.2.3 All electrical work associated with the installation shall comply with the requirements of the Municipal Authorities and shall be carried out in accordance with the latest edition of the "Standard Regulations for the Wiring of Premises".
- 1.2.4 Alternative equipment, materials or apparatus from those that are noted or required on the drawings and/or in the Specifications, may only be offered and supplied on the written approval of such equipment, material or apparatus by the Engineer.
- 1.2.5 All things being equal, preference will be given to South African manufactured equipment, material or apparatus. In cases where all the necessary information is not supplied by the tenderer, then the Engineer's decision shall be final.

1.3 DX HYBRID AIR HANDLING UNITS

1.3.1 The packaged air conditioning units shall be suitable in all respects for outdoor location and shall be equal to THERMOPAK.

1.3.2 Units shall comprise the following components all housed within, or forming part of, their cabinet:

- Refrigeration Compressors
- Air Cooled Condensing coils
- Condenser Fans and Motors
- Refrigeration pipework and controls
- Refrigerant gas charge
- Direct Expansion Cooling coils
- Centrifugal Supply Air Fans with Motor and Belt Drive
- Electric Heater Elements
- Cleanable air filters
- Mixing plenum with Economy Cycle Dampers
- Electric Switchpanel
- Internal electrical wiring.

1.3.3 Unit casings shall be constructed of not less than 1,2mm thick mild steel panels suitably braced and framed so as to prevent drumming, whilst at the same time being arranged in easily removable panels to facilitate access to any portion of the internal components. Casing panels shall be attached to a sub-frame of welded mild steel sections, which framework shall also hold all internal equipment in position. The casing panels shall be internally lined with "sonic liner" or equivalent non-combustible material, such insulation being adequately secured to the internal surfaces with non-combustible adhesive and mechanical fasteners. All mild steel casing panels and framework shall be thoroughly degreased and then painted with a suitable rustproofing primer prior to the application of two finishing coats of good quality enamel or lacquer in the standard colour of the manufacturer.

1.3.4 Tenderers are to note that the unit casing specification above is the minimum required, and that preference will be given to units having double skin panel construction. Further, preference will be given to units having an outer skin of anodised aluminium, or fibreglass construction.

1.3.5 Units shall contain a minimum of two refrigeration compressors. These shall be of the hermetic or the accessible hermetic type, direct driven by integral suction gas cooled squirrel cage motors, at a rotational speed not exceeding 1500 r.p.m. The compressor shall be complete with positive displacement reversible force-feed lubrication systems, and shall have low oil pressure protection, and shall contain crankcase oil heaters to ensure boil-off of dissolved refrigerant from lubricating oil when the compressors are stationary. Each compressor shall have at least one stage of capacity modulation other than full load and shall be arranged to start unloaded.

Each compressor shall have at least one stage of capacity modulation other than full load and shall be arranged to start unloaded.

1.3.6 Condenser coils shall consist of copper tubes with mechanically bonded aluminium plate fins, all housed in a robust galvanised steel frame and protected with a suitable galvanised wire mesh screen. Suitable space shall be provided at the coil ends in order that tube bends are easily accessible in the event of possible refrigerant leaks.

1.3.7 Condenser fans shall be of the slow-running propeller type, direct driven by squirrel cage electric motors. The units shall be provided with a minimum of two propeller fans, which shall be arranged, preferably for vertical discharge through suitable weatherproofed protective wire guards. The fan and motor bearings shall be of the permanently lubricated sealed type, and the motor shall be resiliently mounted so as not to transmit vibration to the unit casing.

1.3.8 Condenser air intake and discharge arrangements shall be such that no short-circuited discharge air can be drawn back into the air intake.

- 1.3.9 Refrigeration pipework shall be carried out in seamless, refrigeration quality copper tubing, suitable provision being made to ensure that the piping is not subjected to any stresses from vibration of the compressors. The refrigeration system shall be split into at least two stages on the liquid side for adequate capacity control. Refrigerant circuits shall incorporate replaceable core type filter-driers, sight glasses, thermostatic expansion valves and vapour proof insulation on the suction lines. The systems shall be factory charged with Refrigerant 22.
- 1.3.10 Automatic safety controls within the unit shall include a dual pressure switch with manual reset on the high pressure side, and an oil pressure switch with manual reset. Provision shall be made for pressure relief of the high side refrigerant piping in accordance with government regulations. Provision shall also be made for cycling the condenser fans so that the units may be capable of operating down to an ambient temperature of 10°C db .
- 1.3.11 Direct expansion cooling coils shall consist of at least two separate refrigerant circuits and shall comprise of copper tubes with mechanically bonded aluminium fins. The coils shall be encased in a heavy gauge grade 304 stainless steel casing fitted with a 1,2mm thick grade 304 stainless steel condensate pan so sized and located as to prevent entrainment of moisture into the air stream, whilst also ensuring positive drainage of condensate.

Cooling coil sizes shall be selected so that the face velocity does not exceed 2.5 m/s.

- 1.3.12 Supply air fans shall be of the double inlet, forward curved centrifugal type with impellers running in sealed, permanently lubricated ball-bearings incorporating pillow blocks located in the suction eye on both sides of each fan. Fan impellers shall be statically and dynamically balanced, and shall run well below critical speed. Fan assemblies shall be so mounted within the packaged air conditioning unit that they do not transmit any vibration. Where units having more than one fan are offered, these shall all be driven by a common motor.
- 1.3.13 Tenderers are to note that the supply air fan specification above is the minimum required and that preference will be given to units having a single, backward curved centrifugal fan mounted on anti-vibration mounts, and complete with a ventilated removable guard on the V-belt drive.
- 1.3.14 Supply air fan motors shall be three phase squirrel cage type, rated not less than 25% above the power input absorbed by the fans, and shall run at a rotational speed not exceeding 1500 r.p.m. The motor shall drive the fans by means of a V-belt drive having not less than two V-belts.
- 1.3.15 Heater elements shall be of the factory-bent, incoloy type, rated for still air, and fitted into the unit in such a manner as to ensure full air flow over each element.

The heater elements shall be fitted into a withdrawable fabricated galvanised channel frame. The side on which the terminals are located shall be fitted with a terminal base of sufficient size to contain all necessary electrical wiring. The terminal box shall be fitted with a removable weather proofed cover so fastened that no screw shall project into the actual terminal box. The electrical wiring within the terminal box shall be effected in insulated wiring capable of withstanding the temperatures encountered without breakdown of the insulation.

- 1.3.16 Air filters shall be equal to **FIBATRON WP77**, minimum 50mm thick, high performance washable, pleated panel type, housed in adequate holding frames, and fitted with gaskets to ensure a positive airtight seal around them.
- 1.3.17 The return air and fresh air mixing plenum shall be factory installed and shall be of similar construction to the rest of the cabinet. The mixing plenum shall be complete with return air and maximum fresh air volume control dampers equal to those specified later herein.
- 1.3.18 Because of the use of an economy cycle, and the resultant possible low "on coil" dry bulb temperature in the intermediate season, the compressors shall be protected by low limit thermostats positioned in the mixing plenum, and set to prevent the compressors from operating at a mixed temperature below 18°C.

- 1.3.19 A weatherproof electrical switchpanel shall be incorporated to form part of the unit, and shall house all the necessary switchgear and controls required to operate the various components within the units. The switch panel shall comply with best modern practice, and shall incorporate all necessary protection against overload or short-circuit. The switchpanel shall be fitted with a suitably sized main isolator backed up by High Rupturing Capacity fuses with a minimum capacity to suit the system fault level. In addition phase failure relays shall be incorporated to protect against low voltage or phase failure. The switchgear shall be fully interlocked so that cooling and heating cannot operate simultaneously, and so that the compressors cannot operate unless the condenser fans and supply air fans are operational. A run down timer shall be incorporated so that the supply air fans shall continue to run for three minutes after the unit is switched off. The switchpanels shall be fully labelled with engraved black ivorine labels having 6mm high white lettering. The labels shall be rivetted to chassis plates to identify all switchgear, relays, instruments and controls inside the switchpanel.
- 1.3.20 Wiring within the switchpanel and the unit shall comply with wiring regulations as relevant, and shall be neatly grouped in horizontal and vertical runs in P.V.C. trunking. All wiring shall be colour -coded in the colours red, yellow and blue for the relevant phases, and black for neutral, the busbars being similarly marked. Busbars shall be copper of adequate cross sectional area, suitably spaced and mounted on stand-off type porcelain insulators. All exposed current carrying parts must be fully insulated with P.V.C. tape of the colours mentioned above. Every wire inside, and outside the switchpanel, shall be fitted with ferrules and shall be labelled with identical numbers at both ends. All outgoing leads shall be connected to a clearly marked terminal strip.
- 1.3.21 All equipment stored or installed on site shall be adequately protected at all times, until the final overall acceptance of the entire installation by the engineer.

1.4 **REFRIGERATION PIPEWORK**

- 1.4.1 Refrigeration piping shall be carried out in seamless, bright, clean refrigeration quality copper tubing and recessed solder joint fittings. Fittings shall be wrought copper or tinned cast brass. Soft annealed tubing shall be used on all pipe sizes below 19mm O.D. ,whilst hard drawn tubing shall be utilised on all larger sizes. All pipe cuts shall be neatly reamed and cleaned prior to making joints. Silver solder shall be used and tubing shall be protected against oxidation during silver soldering by the use of dry nitrogen flowing through the tubing.
- 1.4.2 Liquid refrigerant lines shall incorporate the following components:-
- Bypass flow replaceable type filter driers, of angle type and rated for the full refrigeration duty of the system.
 - Y - type full flow strainers.
 - Isolating valves of the diaphragm type.
 - Moisture indicating type liquid sight glasses.
 - Angle type, backseating, capped liquid charging valves with flare charging connections fitted with flare-fitting cap nuts.
 - Liquid line solenoid valves.
 - Thermostatic expansions valves of the external Equaliser type.
- 1.4.3 Suction lines shall be vapour proof insulated with 25mm thick, preformed "**ARMAFLEX**" or equal insulation. The "**ARMAFLEX**" insulation lengths shall be applied to the piping as and when the joints are being soldered in order to reduce the joints in the insulation to a minimum. Once the piping has been tested for leaks the insulation joints shall be glued and taped.
- All visible refrigeration piping and/or piping exposed to the weather shall be housed within galvanised, or ultra violet resistant P.V.C. trunking.
- 1.4.4 Refrigeration pipework shall be supported at centres not exceeding 2,4m. Pipes shall be securely clamped to points of support using suitable holderbats. Insulated piping shall have moulded cork inserts of 25mm thickness and 50mm width in place of normal insulation where supports occur, vapour proofing at such points being carefully executed. Vibration eliminators of "**ANACONDA**" or equal make shall be installed where indicated on the drawings and the piping shall be supported immediately after such vibration eliminator.
- 1.4.5 All refrigeration pipework passing through walls and concrete floor slabs shall have P.V.C. sleeves within minimum 3mm thickness for the full depth of the wall and/or floor.
- 1.4.6 The sensing bulb of the thermostatic expansion valve shall be securely fastened to the suction line using a copper strip and brass screws.
- 1.4.7 Care shall be taken to ensure that pipework is neatly run in straight lines, this applying especially to soft copper tubing. Pipes shall pitch 25mm in 6m in the direction of flow to ensure oil return.

1.5 REFRIGERANT CHARGE

- 1.5.1 Refrigerant pipework systems shall be charged with refrigerant after evacuation and testing for leaks as outlined below:-
- 1.5.2 Complete refrigeration circuits shall be tested by means of dry Nitrogen to a pressure of at least 50% above working pressure. With the system under the pressure of the Nitrogen, all possible points of leakage shall be brushed with a solution of soap and water to which a few drops of Glycerine have been added. All soldered joints shall be tapped with a hammer to break possible flux seals. Any leaks which may be found by bubbling of the soapy water should be made good after the Nitrogen has first been released. When a leaking joint is detected, the fitting shall be taken out, cleaned and resoldered into the pipework again.
- 1.5.3 Systems should next be charged with Refrigerant to a minimum pressure of 200 kPa and then brought to a pressure of at least 50% above working pressure with dry Nitrogen. A "**HALIDE**" or Electronic leak detector shall at this stage be used to detect any further leaks.
- 1.5.4 Systems found to be free of leaks shall remain under pressure for a 24 hour period. If no pressure drop is observed after this period, taking into account ambient air temperatures, the Nitrogen mixture shall be discharged to atmosphere.
- 1.5.5 The system shall then be evacuated by means of a suitable vacuum pump to a vacuum of 2,5mm of Mercury, allowed to stand for 12 hours, and, if no pressure rise has occurred, shall be charged with refrigerant via the charging valve.

1.6. DUCTWORK

1.6.1 Ductwork shall be carried out in accordance with the details shown on the Drawings, and shall be fabricated from prime quality galvanised sheet steel. All duct sizes indicated on the drawings are metal sizes, and include the necessary allowances for any internal insulation which may be specified.

1.6.2 Ductwork shall be fabricated and installed in accordance with the following specification, which shall be read in conjunction with the standards set by the South African Bureau of Standards (SABS) Standard Specification for Air Conditioning Ductwork, SABS 1238-1979, which shall be adhered to in detail except only as hereinafter specified.

1.6.3 Rectangular ductwork sheet steel thickness and cross breaking length shall be as follows:-

Duct Size long side mm	Semi Perimeter	Duct Joint	Sheet Steel thickness mm	Cross Breaking length mm
Up to 750	<1150	Slip & Drive	0,6	2400
Up to 750	>1150	Mez	0,6	2400
760 to 1350		Mez	0,8	1500
Above 1350		Mez	1,0	1500

1.6.4 Longitudinal seams shall be Pittsburgh lock on all duct sizes. Cross joints on concealed ductwork having a semi-perimeter not exceeding 1150mm shall be as follows:-

Duct Size long side mm	Long Side	Short Side
Up to 750	'S= slip	Drive Slip

Cross joints on concealed ductwork having a semi-perimeter in excess of 1150mm shall be of Mez or equal flange type, installed in accordance with the manufacturer's recommendations. As an alternative to the Mez or equal flange joints, 40mm x 3mm angle flange joints may be used.

Cross joints on all exposed ductwork shall be of Mez or equal flange type.

1.6.5 Ductwork supports shall be of rod and angle type, sheet metal straps not being permitted. The size and spacing of these supports shall be as follows:-

Duct Size long side mm	Semi Perimeter	Angles mm	Rods dia mm	Spacing Max - mm
Up to 750	<1150	40 x 2	6	2400
Up to 750	>1150	40 x 2	6	2400
760 to 1350		40 x 3	8	2400
Above 1350		40 x 6	8	3000

Rods shall be cut back so as not to protrude beyond the angle bracket.

1.6.6 Rectangular ductwork shall be regarded as low velocity, low pressure ductwork, suitable for pressures up to 500 Pa and velocities up to 10 m/s. It shall accordingly be fabricated and installed to comply with the above requirements, and SABS 1238-1979.

1.6.7 All cross joints in ductwork shall be sealed with a liberal coating of 3M or equal Duct Sealer. Longitudinal joints/seams exposed to the weather shall be made waterproof.

1.6.8 All duct connections to vibrating equipment shall consist of a flanged joint, followed by a flexible connector, consisting of a neoprene covered, fibreglass cloth, fixed on either side of the joint in a double lock seam, to form an airtight flexible joint with a minimum of 50mm separation between metal edges. Ducting at flexible joints shall be so supported that the ductwork is held square with the adjoining ducting and no stress is imposed upon the flexible joint. Copper earthing straps shall be fitted over all flexible duct connections and be carried out in accordance with the standard wiring regulations.

The flexible connections exposed to the weather shall be covered with a sheetmetal strip, to protect the flexible material from direct sunlight.

1.6.9 Flexible ducts shall be **EUROPAIR INSULATED ISODEC – TYPE 25A**, or approved equal. They shall comprise aluminium innercore, shielding the fibreglass insulation from the airstream. The outerjacket / vapour barrier shall be of a very tough spirally reinforced multiple layer aluminium laminated construction. Where flexible ducts connect to normal sheet metal ductwork or other equipment, a liberal coating of 3M or equal Duct Sealer shall be used, the joint then sealed with **DURO – DYNE**, or equal, 75mm wide duct tape, and finished with an approved clamp or metal strap to ensure an airtight joint.

1.6.10 Circular flexible ducting connected to supply air diffusers shall not exceed 1,5 metres in length.

1.6.11 All supply air ducting shall be pressure tested with a maximum permissible leakage of 5% at a test pressure of twice the working pressure.

1.6.12 The maximum permissible leakage rate for return and ventilation air systems shall not exceed 5%.

Kitchen canopy and fume extract air ducting systems shall be made 100% airtight.

1.6.13 All insulated ducting in storage, or in position, shall be adequately protected at all times.

1.6.14 All ducting joints exposed to weather shall be waterproof and corrosion free.

1.6.15 All ducting exposed to the weather shall be painted as per Clause 4.36.2 of this section. Colour coding shall be as per Clause 4.36.6 of this section.

1.7 **DUCTWORK INSULATION**

- 1.7.1 Ductwork shall be insulated according to the requirements noted on the Drawings and in accordance with the following specifications.
- 1.7.2 Where noted on the Drawings, the supply air ducting shall be internally insulated with 25mm thick "sonic liner" or equal, glued to the inside surface of the ducting with a fire retardant adhesive. In addition the insulation shall be further mechanically secured with Grip Nails, or 'Spotter Pins', at 450mm centres, and not more than 75mm from the edges of each panel. The insulation ends shall be covered with 0,8mm thick galvanised metal strips rivetted to the duct panels to prevent erosion of particles of the insulation into the air stream.
- 1.7.3 External supply and return air ducting shall be internally insulated with 50mm thick "sonic liner" or equal, glued to the inside surface of the ducting and mechanically secured as specified in clause 17.2 above.
- 1.7.4 Ducting installed in open roof spaces above insulated ceilings shall, in addition to being insulated internally with 25mm thick "sonic liner" or equal in accordance with clause 16.2, be wrapped externally with 50mm thick "foil faced" or equal fibreglass insulation, unless otherwise noted on the drawings. This external insulation shall be strapped around the ducting with strapping bands fixed at 1200mm centres, and joints sealed with foil duct tape.
- 1.7.5 Ventilation ducting only installed above ceilings and below concrete slabs shall be uninsulated, unless otherwise noted on the Drawings.

1.8 **DIFFUSERS. GRILLES AND LOUVRES**

1.8.1 Air distribution shall be effected by means of ceiling diffusers or grilles of the sizes, types and having the discharge patterns as indicated on the Drawings.

1.8.2 Ceiling Diffusers and grilles shall be fixed to spigots extending not less than 100mm from the ducting, unless otherwise indicated on the Drawings, and shall be securely fixed so that no screws or other fixing devices are visible.

1.8.3 Supply air diffusers shall be of steel construction, and shall consist of an inner core which shall be easily removable from the outer section to facilitate access to the volume control damper located behind the diffuser. The inner core shall consist of concentric rectangular collars and the outer section shall consist of a single rectangular or bevel collar provided with a concealed spigot for attaching the diffuser to the supply ductwork.

The rear backing including the disc of all supply air diffusers for coastal projects, shall be lagged with a minimum 3mm thick life care - fire and heat resistant foam.

Supply air diffusers shall be equal to **RICKARD** model CCD or VCD, complete with dampers, and shall be finished in an epoxy powder coating in a colour to suit the Architects requirements. Alternatively fibreglass or aluminium diffuser casings will be acceptable.

1.8.4 Supply air grilles shall be of the double deflection type, consisting of two rows of individually adjustable aerofoil section vanes, the front vanes being horizontal and the rear vanes vertical. The vanes shall be housed in a surrounding fixing flange with neat mitred joints at the comers. The entire grille assembly shall be of extruded aluminium construction and shall be finished in plain anodised aluminium unless otherwise noted on the Drawings.

Supply air grilles shall be equal to **EUROPAIR OR TROX** complete with factory fitted opposed blade dampers.

1.8.5 The multivane opposed blade dampers provided with supply air diffusers and grilles shall be finished in matt black lacquer. The dampers shall be attached to the rear of the grilles and fitted into the spigot connections or the diffusers and shall be adjustable, by means of a key or a lever, from the front of the installed diffusers and grilles.

1.8.6 Return air grilles shall consist of aluminium grid core housed in an extruded aluminium fixing flange with neat mitred comers and finished in plain anodised aluminium, unless other noted on the Drawings.

Return air grilles shall be equal to **EUROPAIR OR TROX** with a 12mm grid core.

1.8.7 Door grilles shall be of extruded aluminium construction, equal to **EUROPAIR OR TROX** suitable for fitting into doors of varying thickness, and shall be finished in a colour to suit the Architects requirements. Door grilles shall be fixed to doors by means of countersunk screws with a colour to match the door grille.

1.8.8 Outside air intake weather louvres shall be of the extruded aluminium, fixed vane type, fitted with a metal vermin proof screen on the rear side, as well as an opposed blade damper.

Dampers shall be provided with a locking device so that once they have been set for the correct air flow they can be permanently locked in position. Louvres shall be finished in plain anodised aluminium.

Where indicated on the Drawings the outside air intake louvre assembly shall be fitted with filter holding frames, with firmly fixed foam rubber gaskets and spring clips, for the attachment of the fresh air filters, as later specified herein. The frames shall be fixed to the weather louvre so as to prevent any air by-passing the filters.

1.8.9 Rubber gaskets shall be glued to the rear of the fixing flanges of all diffusers, grilles and louvres, to ensure airtight seals and prevent smudging.

1.9 **DAMPERS**

1.9.1 Dampers shall be provided where shown on the Drawings for shut-off, bypass or volume control purposes, or where required to comply with local fire codes.

1.9.2 Volume control dampers shall consist of multiple blades acting in opposed blade manner, the blades being robustly linked together to operate in complete unison. Individual blades shall be hooked-edge construction, so bent for rigidity. The blades shall have steel trunnions mounted in bronze sleeve bearings or ball bearings. Permanently set dampers shall be provided with suitable devices to facilitate locking them in position, with 'Open' and 'Shut' position indicated.

Motorised dampers shall include suitable fastenings and supports for motor actuators.

Damper hardware shall be the product of an accredited manufacturer of such items, equal to **DURO-DYNE**. Damper sections shall be housed in flanged steel metal casings of 1,6mm thick galvanised steel. Damper blades shall not exceed 200mm in width and 1000mm in length. Dampers over 1000mm in length shall be sectionalised into separate cells, each with its own shaft and bearings, to ensure that the blade length of each section does not exceed 1000mm.

1.9.3 Fire dampers shall be equal to **BLENDAIR** or **TROX**, and manufactured to a recognised fire code with a two-hour fire rating. Damper casings shall have flanged ends and damper blades shall not exceed 300mm in width. The fire dampers shall comply in all respects with the requirements of the local municipal fire authorities in the area where they are to be installed.

Damper blades shall be closed by the operation of approved fusible links, located where they would be immediately affected by an abnormal rise in temperature of the air stream. When called for on the Drawings, the blades shall also be actuated by solenoid operators which shall be provided by the damper manufacturer. When closed the blades shall be held by a catch arrangement so as to provide a positive seal against the air stream.

1.9.4 Duct mounted air volume control dampers and fire dampers installed in ducts shall be provided with a minimum 300 x 300mm inspection opening, so that the dampers may be checked, maintained and reset when required. These inspection openings shall be covered with suitably sealed access panels.

1.10 SOUND ATTENUATORS

1.10.1 Sound Attenuators shall be provided and installed in the positions indicated on the Drawings, and shall be selected to provide the Noise Criteria levels specified hereof. Sound Attenuators shall be of factory fabricated type equal to those manufactured by **SOUND ATTENUATORS LIMITED**.

1.10.2 The sound absorbing lining material shall impart no odour to the air, shall not delaminate readily, and shall have no loose material or any exposed surface that may be detached by the air stream either during installation, or under regular operating conditions. The material shall also be non-combustible.

1.10.3 All lining material shall be in good condition at the time of final inspection. Material that has been damaged in shipment by rough handling, vibration or exposure, shall be rejected. Material that has been damaged prior to final inspection shall be replaced or coated to prevent detachment of loose material as directed by the Engineer.

1.10.4 Sound absorbing lining material generally shall have a density of not less than 16kg per m³, a thickness of not less than 25mm, and sound absorbing efficiency at each frequency of not less than the following:-

Frequency cycles per second	250	500	1000	2000
Percent absorption	45	65	65	80

1.10.5 The factory fabricated sound attenuators shall be complete units consisting of an outer casing, sound absorbing material and internal baffles and supports. Casings shall be made of zinc-coated steel, not lighter than that specified herein for ducts of the same outside dimensions.

1.10.6 Sound attenuators installed in any extract system from a kitchen canopy shall be Melinex lined.

1.10.7 Sound attenuators that form part of a system that operates under smoke/fire conditions shall have their lining covered with perforated plate.

1.11 AIR FILTERS

- 1.11.1 Air filters shall be installed before the coils in the packaged air conditioning units and the air handling units, and shall be equal to **FIBATRON WP77**, minimum 50mm thick, high performance, washable, pleated panel filters.
- 1.11.2 Long life air filters installed in independent air filter banks in Plantrooms, or before the coils in packaged air conditioning units and air handling units, where indicated on the Drawings, shall be equal to **BRANDT EXPO 3000** extended surface air filters with **VILEDON** type PSB 290 filter media having an arresance of 90% (ASHRAE). Each filter cell shall be suitable for the manufacturer's recommended air flow of 0,833 m/s at an initial resistance of 20Pa. Manometers to be used in conjunction with these filters shall be set for a final resistance of 150 Pa.
- 1.11.3 Fresh air filters shall be of the same make, type and size as the return air filters fitted in the units, and shall be fitted into the holding frames installed on the rear of the outside air intake weather louvre, so as to be easily removable from inside the plant room area or building.
- 1.11.4 Air filters shall be fitted into holding frames which shall be so designed to allow a negligible quantity of air to bypass the filters.
- 1.11.5 All filter banks shall be mounted in easily accessible positions and shall be reachable with a normal 1.8m long ladder.

1.12 ELECTRIC MOTORS

1.12.1 All electric motors on the installation shall be of one make unless forming an integral part of the equipment served, and shall not operate in excess of 1500 r.p.m., unless approved by the Engineers for specific applications.

1.12.2 Motors shall be 380 volt, three phase, 50 Hertz for all sizes from 0,4 kW upwards. Smaller motors may be 220 volts, single phase, 50 Hertz.

1.12.3 All motors shall be of the totally enclosed, fan cooled type, and shall have metric frame dimensions. Motors shall be quiet in operation and corrosion free to the full acceptance of the Engineers.

All electric motors for outdoor condensing units shall be of the weatherproof type, and all motor components shall be corrosion free.

1.12.4 Three phase motors shall all be squirrel cage, induction type, with special high torque motors being used on high inertia loads such as large centrifugal fans.

1.12.5 Starting methods for three phase motors shall be in accordance with local regulations. In the event that these regulations are not available at the time of tender, the following starting methods shall be allowed for:-

Motors up to	4 kW	direct-on-line
Motors above	7 kW	Star-delta (where the site is not serviced by its own transformer)
Motors above	22,5kW	Auto transformer started in three steps

1.12.6 Single phase motors shall be of the capacitor run or start type, protected by a manual reset overload.

1.12.7 The nameplate rating of electric motors shall be at least 15% greater than required, on motors below 15kW. On larger motors a 10% margin shall be allowed.

1.13 ELECTRODE HUMIDIFIERS

1.13.1 Electrode type, steam generating humidifiers shall have the capacities as called for in Part Two of the Specification.

1.13.2 Humidifiers shall be installed in full accordance with their manufacturer's instructions, with their steam injection nozzles fitted in the positions indicated on the Drawings.

1.13.3 Humidifiers shall be piped to suitably selected steam injection nozzles, each being of sufficient length so as to extend over the full length of the coils or the ducts, or be the maximum standard length available for the manufacturer's of the humidifiers, and positioned for optimum mixing of the steam discharge with the air, without condensate forming on any adjacent casings or inside the supply air ducts. Should steam distribution hosing runs, because of their length, cause excessive steam temperature drop and a consequent high rate of condensate within them, then the hoses shall be insulated with suitably sized light density, performed fibreglass sectional lagging, covered with P.V.C. plastic sheeting, overlapped over each section, and fixed with approved adhesive.

Each humidifier shall be supplied with two sets of spare replaceable electrode elements.

1.13.4 Water connections to, and drain connections from, the humidifiers shall be carried out in water quality tubing using **SECUREX**, or equivalent compression type fittings. The mains water serving the humidifiers must **NOT BE TREATED**, and shall be taken from the mains water supply connections to be provided by others, in each plant room, in the positions indicated on the drawings.

1.14 AUTOMATIC CONTROLS

1.14.1 Provide, install and set into operation all the automatic control devices shown on the relevant Diagrams, and interlock same as required to perform their function correctly. The Contractor shall note that the various controls shown on the drawings, and as mentioned herein, indicate the basic control elements and functions required only. They shall additionally furnish all ancillaries necessary to fulfil the desired plant operation.

1.14.2 All control equipment shall comply with the following:

1.14.3 Valve and damper operators shall be quiet in operation. In the event of power failure, operators shall be provided with spring return so that they will "fail safe" in either the normally open, or normally closed position as required.

Operators operating in sequence with other operators shall have adjustable operating ranges and starting points, to permit adjustment of the control sequence as required by the operating characteristics of the system.

1.14.4 Temperature and Humidity controllers shall be of the type specified in Part Two of the Specifications, and as indicated on the Wiring diagrams.

Thermostats shall have bimetal, vapour pressure, liquid filled, or resistance type sensitive elements, and humidistats shall have sensitive elements of human hair, or other suitable material of approximately equal sensitivity, or of the hygroscopic resistance type.

Room thermostats, electronic sensors and room humidistats shall be securely attached to suitable bases mounted on the walls or other building surfaces. Each thermostat, electronic sensor or humidistat shall be located where shown, or, if not shown, where it will respond to average temperature or humidity in the area controlled.

Thermostats, sensors and humidistats generally shall be mounted 1,8m above the floor, unless otherwise indicated on the drawings, and shall not be mounted on outside walls or partitions if other locations are possible.

Thermostats mounted on outside walls shall be provided with insulating bases.

Room thermostats and room humidistats in which the adjusting mechanism is integral with the sensing element shall have locked, or concealed adjusting devices, by means of which the operating points can be adjusted through a range of not less than 5 degrees and 10 per cent, respectively, above and below the operating points specified.

1.14.5 Electric temperature control systems operating at less than the normal lighting circuit voltage shall be provided with transformers to supply power for the equipment.

Transformers and line voltage controllers serving individual ventilation or air conditioning units may not be fed from the fan motor leads.

Transformers other than transformers in bridge circuits shall have primaries wound for the correct control circuit voltage. Each transformer shall have adequate capacity to operate simultaneously all apparatus connected to it, and shall be capable of carrying a 25 per cent overload for one hour. Each transformer shall be enclosed in a steel cabinet with conduit connections, and shall have a fused disconnect switch on the primary side, and a fuse cut-out, or thermal cut-out, on the secondary side, if the output exceeds 50 volt amperes. One leg of the secondary winding of every transformer shall be properly earthed.

1.14.6 **AIR CONDITIONING, VENTILATING, HEATING AND EXHAUST PLANTS**

1.14.7 Plants shall be switched ON and OFF automatically, by means of an electrically operated time switch, driven by a totally electronic unit to allow the switch to continue operating, without interruption to its programme, during power failure of up to eight (8) hours.

Time switches shall be installed within the electrical switchpanel, and shall be interlocked with a rotary type MANUAL\OFF\AUTO over-riding control switch, so that the plant may be operated manually, or switched off on Public Holidays, without interruption of the programme of the time switch.

MANUAL\OFF\AUTO switches shall be mounted in the positions indicated on the Drawings.

Where applicable, as indicated on the wiring diagrams, the time switch shall be replaced with an optimised start control system equal to **LANDIS & GYR, STAEFA, SATCHWELL** or equal, which shall automatically start and stop the plant. The control shall include an outdoor and indoor thermostat which shall influence the plant starting time, to ensure the desired indoor temperature at the beginning of the occupied period.

- 1.14.8 Where applicable, as indicated on the relevant Diagrams, plants shall be protected against low voltage or single phasing by an electronic single phase/low voltage monitoring device, pre-set to trip the entire plant should the line voltage drop by more than 10%, or the loss of one or more phases. The device shall be set to reinstate the operation of the plant five minutes after the voltage has returned to normal.
- 1.14.9 Fire safety thermostats of the rigid tailstock type shall be mounted in the return air stream to each unit, or behind the common return air opening to the plant room, as applicable, and if indicated on the drawings, to sense the return air temperature and shut-down the entire system should the return air temperature exceed $\pm 40^{\circ}\text{C}$. These safety thermostats shall be of the manual reset type.
- 1.14.10 Plants shall be started in sequence by means of time delay relays. The timing between switching stages shall be set at not less than 20 seconds.
- 1.14.11 Where applicable, the temperature control circuit of each compressor unit shall be interlocked with the condenser fan switch so that the compressors will not operate unless the fan switch contacts are closed.
- 1.14.12 Cooling and heating thermostats, or temperature sensors, shall be installed in the positions indicated on the Drawings to control cooling and heating through the number of stages as called for in the Specification.
- 1.14.13 Thermostats or temperature sensors positioned within the conditioned space shall be mounted on neat, recessed wall boxes of sufficient size, so as to project at least 25mm on all sides of the controller.
- 1.14.14 Each refrigerant circuit within the packaged air conditioning units shall include a dual pressure switch with manual reset on the high pressure side, and an oil pressure switch, with manual reset feature, to stop the compressor if the oil pressure drops below a preset minimum, all as previously specified herein.
- 1.14.15 Ventilation fans shall be interlocked with the air conditioning plant as called for on the relevant Drawings.

Fresh air intake fans shall be interlocked to operate only when the plant is switched on.

An additional manual override facility shall be provided to operate fresh air fans, for service inspection purposes.

Exhaust fans will be switched on and off at their relevant control points.

1.15 SWITCHPANELS AND CONTROL BOARDS

1.15.1 Provide and install, in the positions indicated on the Drawings, switchpanels and control boards complying in operating principals with the automatic control sequence as described before.

1.15.2 Before commencing with the manufacture and wiring of the switchpanels and control boards, the Contractor shall submit three copies of up-to-date Wiring Diagrams, schematic ladder type Diagrams of the control systems, and dimensioned panel layout Drawings to the Engineer for approval. All Drawings shall show the correct terminal numbers and wire identification numbers to be used.

The Engineer shall be informed of all modifications to the wiring made until the end of the guarantee period, and updated drawings shall be submitted immediately after each modification is made.

1.15.3 The complete electrical installation, and all electrical equipment and material covered under the Sub-contract shall comply with the latest edition of the S.A.B.S. Code of Practice. The workmanship and installation shall comply with the S.A.B.S. Code of Practice for the wiring of premises, the Factories, Machinery and Occupational Safety Act of 1984, Local Municipal Regulations and Bye Laws.

All components of a similar nature shall be of one make with corresponding parts being interchangeable. All equipment shall be of robust construction and have ample ratings for the duties imposed.

1.15.4 The System Fault Levels for which the switchpanel components shall be designed and selected shall be 10KA, or as otherwise noted in the specification, for each switchpanel and control centre.

All equipment in the switchpanels such as fused switches and moulded case circuit breakers, for controlling outgoing circuits, shall be rated accordingly.

1.15.5 Switchpanels and control boards shall be of the floor mounted type for panels having a total face area in excess of 1,2 m², and wall mounted if less than 1,2 m². Where switchpanels exceed 1,2 meters in length they shall be divided into multi-sections.

Switchpanels shall be arranged for front access only, and bottom cable entry with the main incoming isolators positioned on the extreme left hand side of each switchpanel. All switchpanels shall be arranged for top exit via cable ducts.

When starting equipment creates higher than normal ambient temperatures, the switchpanels shall be adequately ventilated by means of splash-proof, top ventilation openings provided with vermin proof screens.

Switchpanels and control boards shall be the products of specialist manufacturer's of this class of equipment, as approved by the Engineer, and shall be purpose made to contain all switchgear, controls, instruments and indicating equipment, and shall be complete with all internal wiring, all conforming with the following requirements.

1.15.6 Switchpanel and control board casings shall be fabricated from 2,0mm thick mild steel suitably stiffened with mild steel sections and fitted with removable, hinged doors, with flush-mounted locks each provided with triplicate keys, as well as removable panels secured with chromium plated dome nuts.

Wall mounting panels shall be of the surface type with removable inner mounting chassis.

Floor standing switchpanels and control centres shall be mounted on channel section, mild steel bases.

Door widths shall not exceed 900mm for all switchpanels. All doors, removable covers, door pillars, mullions, etc., shall be dust resistant and provided with oil resistant, closed-cell composition, synthetic rubber or similar gaskets. Gasketed surfaces shall be so constructed that gasketing material is retained by metal channels, and does not depend entirely on an adhesive holding the gasket on a flat metal surface.

All fixing screws shall enter holes tapped into an adequate thickness of metal, or nuts welded to the back surface of the metal plates. Self-tapping screws will not be accepted.

Switchpanels shall be so designed that no circuit breaker toggles shall protrude through the doors. All switches, the main circuit breakers, on/off handles, instruments and indicating equipment, reset buttons and pilot lamps only shall, however, be fully exposed and operable, as relevant, without the need to open the doors to the switchpanels, this equipment being flush mounted on the door of the switchpanel or on a fixed panel section on one side, or on top of the switchpanel.

Adequate barriers shall be provided in the switchpanels to segregate load circuit compartments from the busbar chamber, in such a way that transmission of flame from one compartment to another is minimized.

The electrical equipment within the panels shall be mounted on a steel chassis. The chassis shall also be used for the mounting of the relevant busbars.

Finish of the panels shall be in enamel. Orange on the outside and White inside. Boards shall be given three coats of paint after an initial coating of zinc-rich primer, to give a high-class gloss finish. Colour samples of the Orange enamel paint shall be approved by the Engineer prior to the switchpanels being painted. All switchpanels and control boards shall be fitted with earthing straps, in accordance with the standard wiring regulations.

1.15.7 Busbars shall be provided in hard drawn annealed copper, loaded to not more than 1,55 Amps per mm² of copper, on a $\pm 50^{\circ}\text{C}$ rise, and shall be enclosed in a top horizontal and accessible compartment, with steel casing separating the busbars from other equipment. Busbars shall be mounted on porcelain or epoxy resin type busbar insulators mechanically braced to withstand 40 kA through fault current. The clearance between busbars shall not be less than 40mm between phases, and 25mm to earth, and they shall be secured by bolts having a diameter of not less than the thickness of the busbars, with a minimum diameter of 8mm. Machined bolts and nuts with washers and spring washers shall be used, and busbar supports shall have a maximum pitch of 900mm. Connections shall be made by means of copper, preferably double indent, compression lugs. All busbar joints shall be silver or tin plated, and connected with high tensile steel cadmium plated bolts and lock washers. Busbars shall be taped after all connections are made. Busbar droppers to circuit breakers shall be of minimum section 10 mm², single copper conductor.

1.15.8 Neutral bars are to be not less than half the cross-sectional area of the phase busbars, but not less than 25mm x 6mm, and are to be mounted on porcelain or epoxy resin type insulators, where heaters or other phase to neutral loads are used.

Where neutral bars are purely on the control side, 15mm square brass bars with 2 tapped holes per way may be used, mounted on bakelite or equal insulators.

1.15.9 Earthing straps of not less than 25mm x 6mm copper shall run the full length of the complete floor standing panels, either at the top or bottom of the panels, where it must be securely bolted to the switchpanel framework to ensure good continuity.

Wall mounted switchpanels shall be provided with an earthing brass bolt of not less than 10mm diameter, securely fixed to the panel chassis.

1.15.10 All wiring within the panels shall be neatly grouped in horizontal and vertically run, approved fire resistant P.V.C. trunking, with dip-on removable covers. All wiring shall also be colour-coded in the colours red, white and blue for the relevant phases, and black for neutral, the busbars being similarly marked.

Power wiring shall be of 2,5 mm², minimum section P.V.C. covered, stranded wire, rated for 600 volts.

Control wiring from the secondary side of control transformers shall be minimum 1,5mm², P.V.C. covered, stranded, 250 volt grade wire with bared ends soldered. All switchpanels shall be carefully designed and sized to ensure ample space for wiring and making-off incoming cables.

1.15.11 Where required (due to fault level considerations), Current Limiting Circuit Breakers shall be used to reduce fault current levels to less than 5kA r.m.s., alternatively 7,5 kA "let-through-current". The circuit breakers to be used shall be the manually operated, trip-free type, with adjustable magnetic\thermal trips in each phase.

1.15.12 All fuses shall be of the HRC type, with minimum rupturing capacity to suit the system fault levels at 400 volts. Spare fuses of 25% of the total quantity, with a minimum of three of each size and type, including control circuit fuses shall be provided.

1.15.13 Isolators shall be of the 'on load' type, and of ample rating for the maximum load applicable. Live side terminals on all isolators must be shrouded or otherwise insulated against inadvertent contact.

Isolators installed within the switchpanels shall be housed in separate enclosures, the door of which shall be interlocked with the switch operator, to prevent the door from being opened unless the switch is in the open position, and prevent closing of the disconnect switch while the door is open, unless a manual by-pass is actuated, also to prevent closing of the disconnect switch until the door hardware is fully engaged. The stem operating the isolator shall not be less than 12mm in diameter, and shall not protrude more than 100mm. Provision shall be made for padlocking the disconnect switch in the open position only, with up to three 10mm shackle padlocks regardless of whether the door is open or closed.

1.15.14 Air break circuit breakers shall be of the double break type, and shall have a continuous rating not less than the total full load rating of the equipment. They shall have a fault capacity suitable for the design level of the system. They shall have adjustable overloads, covering the operating range of the equipment served. which shall be series tripping up to 800 Amp and C.T. operated above this value.

1.15.15 Moulded case air circuit breakers shall be rated to comply with a minimum fault level of 6kA, and a current rating to suit the load and shall be fitted with thermal overloads and instantaneous magnetic, over-current release.

1.15.16 Current transformers shall be air insulated and shall have an accuracy within 2% of the 0-100% scale output. One leg of the secondary winding shall be solidly earthed.

1.15.17 Magnetic contactors shall not be smaller than N.E.M.A. size 1 or equivalent, with encapsulated operating coils rated at 220 Volt, 50Hz. Each starter is to be furnished with one spare N.O. (Normally Open), and one N.C. (Normally Closed), auxiliary contacts rated at 5 amperes. Each starter shall also have provisions for adding two additional sets of auxiliary contact, either normally open or normally closed. Contacts and coils shall be replaceable without removing the entire contactor from the cubicle.

1.18.18 Motor Starters shall comply with BS 775 and N.E.M.A. specifications, and shall have thermal overload relays, which shall be of the bimetallic, ambient temperature compensated, manual reset type. Overload relays shall be resettable at any time after tripping, without rendering the relays inoperative. All terminals shall be shrouded, and the contact mechanism shall be trip-free, so that the snap action contacts cannot be held closed against continued overload. The ultimate trip current of overload devices shall be nominal 115% of the motor full load current.

With special hard starting, e.g. centrifugal fans, it may be necessary to increase the nominal value, but in no case shall the overload ultimate trip current exceed 130% of the motor full load current.

- 1.15.19 Control relays shall be either of the heavy duty industrial type, 600 volt with minimum 10 ampere replaceable contacts and shall be equipped with 110 volt, 50 Hz holding coils for continuous operation within a voltage range of 100 to 120 volts. Holding coils shall be replaceable without removing the entire relay from the cubicle or; alternatively the control relays may be of the plug-in type, hermetically sealed in plastic containers.
- 1.15.20 Phase failure SEQUENCE PROTECTION Relays shall be arranged to shunt trip the incoming breakers so that on failure, or phase reversing, the plants will stop. The relays shall be equal to **ELECTROMATIC**.
- 1.15.21 Timers shall be of the totally electronic unit type similar or equal to **SIEMENS**.
- 1.15.22 Sequence controllers to start plant with a minimum of 20 seconds time delay between each start-up of motors of 3kW and over shall be provided to avoid heavy current inrush on plant start-up. Sequence controllers shall be totally electronic unit type, and shall automatically recycle to zero position after power interruption, and on normal plant shutdown.
- 1.15.23 Pilot lights shall be of the neon or incandescent type, equal to **SIEMENS** with round 'Plexiglass' lenses. The colours of the lenses shall be as noted below:-
- | | |
|------------------|-------|
| Indication | Amber |
| Operation | Green |
| Failure or Alarm | Red |
- Pilot lights shall be grouped in the sequence of operation of the plant components, with amber coloured lamps generally above green lamps, and the red 'failure or alarm' lamps below the respective green 'operation' lamps.
- 1.15.24 Reset Pushbuttons shall be similar in appearance and size to the pilot lights, equal to **SIEMENS**, and shall be mounted adjacent to the red failure or alarm pilot lamps on the switch-panels.
- 1.15.25 When indicated on the Wiring Diagrams only, the main incoming switch of the switch panel shall be fitted with a kWh-meter, three Ammeters and one Voltmeter with selector switch.
- Kilowatt-hour meters shall be fitted as specified on the Drawings. The meters shall have 6 digits and manual reset knob. Above 100 Amp the kWh-meter shall be fitted with current transformers.
- Ammeters shall be fitted in the power circuits of all motors of 5kW and over, and where specified or shown on the Drawings. Ammeters over 50 Amps shall be operated by current transformers of the ring type. Ammeters shall have an accuracy of 2% of the scale range or better. For non-inductive loads the scale of ammeters shall not exceed the maximum current drawn by more than 40%. Motor ammeters shall be suitable for the starting current of the motor, and shall have an extended scale in the region of the operating current.
- Volt meters shall be of the moving iron or moving coil type.
- All indicating instruments shall be of the flush mounted square face pattern with 96mm dials.
- 1.15.26 Each control circuit shall be protected with a single pole circuit breaker. Controls shall be suitable for 220 volt operation.
- 1.15.27 Terminal boards, or blocks, shall be mounted in each switchpanel for all external connections, and shall be so located that they are readily accessible from the front of the switchpanel, and not in the wiring gutter, leaving it completely free for power and control wiring. If terminal blocks are of the 'split= disconnect type the female part shall be secured to the removable unit cubicle, and the male part shall be free and of a closepin type. The disconnect type terminal blocks shall be held together with screws or clamps. Terminal strips shall be properly labelled, and panel field wiring shall be marked accordingly by the means of numbered ferrules. Not more than one incoming and one outgoing wire shall be fixed to any one terminal.

Labels showing the unit designations shall be provided adjacent to each of the terminals.

- 1.15.28 The switchpanels shall be fully labelled with engraved white ivorine labels having 6mm high black lettering. The labels shall be fixed securely to switchpanel cover or chassis plates by means of small, self-tapping screws, to identify all switchgear, relays, instruments and controls, etc., on the face of, or inside, the switchpanels.

Equipment operating above 250 volts shall be fitted also with a red danger label.

Embossed Tape or Labels fixed with adhesive will not be accepted.

The Contractor shall be responsible for marking all switchgear and other equipment on the Wiring Diagrams with the wording of the labels to be used.

All cable terminals shall be clearly identified by permanent labels.

Every wire inside, and outside, the switchboard shall be fitted with ferrules, and shall be labelled with identical numbers at both ends.

All terminal numbers and wire identification numbers shall correspond with identical numbers which must be shown on the wiring and control Diagrams.

- 1.15.29 Work tests may be witnessed at the discretion of the Engineer, who shall be given one week's prior notice in writing of the date on which they will take place. Three copies of Wiring Diagrams and ladder type schematic Diagrams, complete with terminal numbers, shall be sent to the Engineers at least fourteen days before testing can be commenced.

Testing shall be carried out on all completed equipment, including:

- High voltage insulation and insulation resistance tests to earth and between phases.
- Satisfactory operation of relays shall be proved.
- Closing and opening operation of all starters and contactors shall be satisfactorily demonstrated.
- All mechanical interlocks shall be satisfactorily demonstrated.
- Satisfactory operation of current and voltage instruments.
- Operation of all control circuits shall be proved by simulating operation of switching devices in the external circuit.

In addition, all components parts shall comply with the type specified in the S.A.B.S. or B.S. Standards.

The pre-delivery tests is not a final acceptance test, and does not absolve the Contractor from his responsibility for the switchpanels.

All protective devices throughout shall be correctly set by the Contractor to the approval of the Engineer. Before any circuit is energised, the data for correct setting is to be established.

The Contractor shall be responsible for the complete electrical installation, i.e. the selection of equipment of appropriate rating and capacity, including the rupture of fuses and circuit breakers, all as covered under this Sub-contract.

- 1.15.30 Provide for each item of equipment located out of sight of the electrical switchpanel serving same, a remote-on-load isolator housed in a dustproof case. Where isolators are located in positions exposed to weather, they shall be of a waterproof type fitted with suitable watertight cable entry glands.

1.16 ELECTRICAL WIRING

- 1.16.1 Electrical wiring shall comply fully with the S.A.B.S. Code of Practice for the Wiring of Premises, and the additional requirements of the local authorities who have jurisdiction over the Site of Works, as well as being in accordance with best modern practice.
- 1.16.2 Main power incomers to plant rooms will be provided by others, excluding making-off of cables within the electrical switchpanels provided by the air conditioning Contractor, who shall attend upon, and liaise with whoever brings power cabling to his switchpanels.
- 1.16.3 Conduits shall be galvanised to S.A.B.S. specification. All joints shall be screwed. No conduit less than 20mm shall be used. Conduit fittings and boxes shall be of galvanised iron to S.A.B.S. specification.
- 1.16.4 Galvanised conduits and conduit fittings shall be installed in positions exposed to weather, or in moist surrounding. Where galvanising has been removed by threading, cutting, etc., the exposed parts shall be suitably treated with cold galvanising to render them weatherproof and rust resistant.
- 1.16.5 Conduit shall either be screwed and locknutted on both sides, and bushed on the inside of the box or appliances in which it is terminated. Only solid brass bushes shall be used. Alternatively, and particularly in distribution boards, conduits shall be terminated with couplings and brass male bushes. PVC conduit will be allowed where it complies with local regulations.
- 1.16.6 Conduit in roof spaces shall be run parallel, and at right angles to roof members, and shall be secured to these members by means of saddles and screws.
- 1.16.7 No conduit is to cross an expansion joint in the structure without an approved arrangement for crossover. Where details of the crossover are not given, the Contractor shall refer to the Engineer for instructions.
- 1.16.8 The Contractor shall notify the Engineer in good time before any conduits in concrete are covered, so that tubing may be inspected and checked before concrete is cast, and shall attend on the Engineer during such inspections.
- 1.16.9 Conduit for future requirements shall be terminated with boxes and overlapping cover plates, and fitted with galvanised steel draw-wires. Where such conduit terminations project from the wall or slab, they shall be fitted with couplings and plugs. Such terminations in exposed positions shall be sealed with bitumen and protected with weatherproofing paint.
- 1.16.10 Inspection facilities shall be provided as specified in S.A.B.S. 0142-1981, Clause 5.4.1.d.
- 1.16.11 Exposed conduits shall be fitted with steel saddles of same finish as conduits, fixed at centres not exceeding 2 meters.
- 1.16.12 Conduit boxes to be cast in concrete shall be secured to shuttering by means of 5mm screws and nuts, unless some other method of fixing is approved by the Engineer.
- 1.16.13 Drawboxes and blank boxes in R.C. slabs, columns or in walls shall be fitted with substantial oversized metal coverplates, fixed with countersunk screws, before surrounding surfaces are painted. Drawbox positions must be approved and care shall be taken that they do not affect the appearance of the building adversely. Where possible a single coverplate shall be fitted for a number of adjacent drawboxes.
- 1.16.14 Drawboxes in roof spaces which are only accessible above ceilings, shall not be installed in positions where clearance from ceiling to roof is less than 1 meter.
- 1.16.15 Blank switch and plugboxes shall be fitted with blank coverplates and screws to match those specified for switches and switch sockets.

1.16.16 Mounting heights of boxes shall be as indicated on the Drawings which shall refer to the distance between the centre of the outlet box and the finished floor level, unless otherwise specified or indicated. Where two similar outlets occur adjacent to each other, these shall line up accurately horizontally, unless otherwise indicated.

1.16.17 When chasing of brickwork is carried out by the Contractor due care shall be taken to prevent damaging of walls during chasing. He must ensure that other trades are not held up owing to delays in such work. Damage to brickwork will be made good by the building contractor.

Under no circumstances is facebrick, or other finished surfaces, to be chased without the permission of the Engineer.

Where it is necessary to chase structural concrete, the permission of the Structural Engineer must first be obtained. Where this is not done and the structure is chased without permission, the Contractor will be held responsible for any damage to the structure which may be caused.

1.16.18 All wiring shall, unless otherwise specified, be carried out with P.V.C. insulated cable to S.A.B.S.150-1970.

1.16.19 Plastic insulated (P.V.C.\S.W.A.) cables shall be to S.A.B.S. 150-1970, and addenda thereto and shall consist of P.V.C. insulated conductors, P.V.C. beddings, galvanised steel wire armouring and a P.V.C. sheath.

P.V.C.\S.W.A. Cable ends shall be made off with approved glands. The glands shall be of the type in which the armouring is clamped between tapered cones compressed by the action of a screw and in which the gland is secured to the outlet casing by means of screwing, and/or locknutting.

Neoprene shrouds shall be used to cover the junction of the cable and the base of the gland.

1.16.20 The wiring in all Plant rooms shall be supported on cable trays or in cable ducts.

Cable supports for single, or not more than a group of three cables, shall be equal to **UNISTRUT** die-cast cable cleats with **UNISTRUT** type P-1000 channel, fixed to walls or overhead slab, at not exceeding 600mm pitch. Cables supported in this manner shall be properly straightened and neatly run to the full satisfaction of the Engineer.

Cable trays shall be run strictly in horizontal or vertical planes, any change of level, however, being done with a 45E slope. Where cables leaving trays drop down to equipment, use minimum tray width of 150mm and two vertical **UNISTRUT** supporting channels fixed to horizontal tray at top and floor at bottom.

1.16.21 All earthing shall be carried out in accordance with wiring regulations, earthing connections being executed with appropriate copper earthing strip, using brass bolts, nuts and washers to ensure continuity to main building earth provided by others.

Each run of P.V.C.\S.W.A. multi-core cable shall carry an additional conductor to be used for earth continuity, and shall be properly made-off for this purpose.

1.16.22 Connections to vibrating equipment shall be made with metal sprague on conduited systems, a separate earth continuity conductor being run outside the flexible conduit.

On cable systems, leave sufficient cable slack to allow free cable movement to take up vibration.

All connections to vibrating equipment shall be made so as not to impose strain on conduits, cables, conductors or equipment, and shall be of sufficient length to allow full adjustment of motors on slide rails.

1.17 INSTRUMENTS

- 1.17.1 Provide and install instruments where shown on the applicable drawings, or mentioned herein as follows. All instruments shall be installed within Plant rooms where possible, and shall be mounted at eye level, and, if necessary, remote sensors shall be provided to ensure eye level accessibility. All instruments shall be installed in positions not affected by plant vibration.

Instruments shall be of the circular dial type, having equal sized dials between 75mm and 100mm in diameter, unless otherwise specified, and the same finish in either stainless steel or chrome plate. All panel mounted instruments shall be suitable for flush mounting and fixing from within the panels, without screws projecting through the panels.

Instruments shall be provided with pointers, or have painted on their dials, green lines to indicate the normal operating ranges of the services indicated, and red lines to indicate minimum and/or maximum limits.

- 1.17.2 Air and water temperatures shall be measured with alcohol in glass type thermometers, which shall have a guaranteed accuracy within 1% around the entire dial range, and a means for recalibrating the instruments on site. Thermometer ranges shall be suitable for the service and shall not exceed 50% above, or below, the normal operating temperatures for each instrument.

Stems or bulbs sensing temperatures in pipes shall be fitted into oil filled wells, and bulbs in ducts or plena, shall be neatly fitted on insulated brackets to the satisfaction of the Engineer.

- 1.17.3 Air pressure gauges shall be 50mm dial, scaled from 0 to 150% of normal operating pressure.

- 1.17.4 Inclined pressure differential manometers shall be installed to indicate the resistance to the air flow over all banks of filters. Each manometer shall be fitted with a spirit level to ensure proper horizontal mounting, and pointers to indicate the initial pressure drop, and when the filter media has to be changed.

- 1.17.5 Static pressure indicators shall be of the diaphragm actuated, dial and pointed type graduated to read from 0 to 50% more than the maximum allowable static pressure, and shall be installed to sense the leaving main supply duct pressure. The gauges shall be connected to static pressure taps of approved design.

1.18 EQUIPMENT BASES

1.18.1 Provide, as called for in Part Two or as indicated on the Drawings, equipment bases of the applicable type as specified below:

1.18.2 Floating steel bases shall be shop-fabricated from mild steel channel sections of sufficient strength and rigidity using welded joints. Such bases shall, unless otherwise called for elsewhere or noted on Drawings, be of rectangular shape, and at least 80mm larger in all plan dimensions than the equipment to be mounted onto it. The construction of the base shall be such that proper provisions are incorporated for attaching laterally, or fitting beneath it, vibration isolators of the type which each application may require. The principal Contractor will provide a level "housekeeping" plinth on which to mount the aforementioned steel base, the plinth to be 100mm minimum larger than the base all round.

1.18.3 Static plinths, 80mm minimum high, shall be provided by the Principal Contractor for mounting non-vibrating equipment upon them, the plinths to be rectangular in shape unless otherwise shown on the Drawings, and 100mm larger all around than the equipment to be mounted upon them.

The Contractor shall provide and position, where required, a channel iron frame, with mitred welded corner joints, and sheet metal bottom tray for the Principal Contractor to fill with concrete. The finish of the plinths shall be tinted granolithic.

1.18.4 Anti-vibration mountings shall be utilised in conjunction with the aforementioned bases, as relevant and as indicated on the Drawings for the following listed items of equipment.

All anti-vibration mountings shall be installed in full accordance with their manufacturer's application instructions, the model numbers mentioned herein referring to equipment of Mason Industries Inc., as locally supplied by **E.M. ARNOT**, although other approved makes would also be acceptable.

1.18.5 All equipment bases and anti-vibration mountings shall be corrosion free.

Equipment	Minimum Static Deflection	Type of Mounting	Model
Air Conditioning units Air Handling units and condensing units on concrete floors or bases		Neoprene Vibration Pads	NK or WMW

-
- 1.18.6 Full details of floating steel bases and all anti-vibration mountings selections shall be approved by the Engineer prior to the mounting being ordered, and the bases fabricated.
- 1.18.7 Where applicable, the Contractor shall exercise particular care to prevent damage to the roof slab when hoisting, positioning and connecting the air conditioning units, and shall note that he will be held responsible for repairs caused as a result of this installation.
- 1.18.8 All equipment, and particularly that which is mounted on the roof, shall operate without objectionable noise or vibration being transmitted to the full satisfaction of the Engineer.
- 1.18.9 All cut joints and holes drilled within ducting, equipment casings, supports, stands, platforms, suspension brackets and supporting cable trays shall be fully protected against corrosion.

1.19 EQUIPMENT SUPPORTS

1.19.1 Where equipment supports, stands, platforms and suspension brackets are indicated, specified or necessary for ductwork, pipework, etc., the Contractor shall provide supporting structures capable of carrying the load without distortion, affixed to the building structure in such a manner as not to subject it to undue stress.

Supporting of any rotating equipment shall incorporate vibration mountings of the type and selection specified in the applicable clauses referring to equipment bases herein.

All methods of suspension or supports shall be submitted to the Engineer for approval, and for reference to the Structural Engineer where necessary, prior to manufacture or installation.

1.19.2 Generally, supports shall preferably be proprietary products such as Unistrut, or failing this, shall be of mild steel sections, purpose fabricated for their application. Under no circumstances whatever will sheet metal straps be accepted as a supporting method. All supports shall cradle the item to be supported; supports shall not be rivetted or welded to the equipment to be carried, except in exceptional circumstances approved by the Engineer. Rod hangers shall not exceed one meter in length, and shall be of minimum diameter 12mm. For longer suspensions use mild steel angles. Angle iron supports shall be of 25mm x 3mm minimum. All supporting structures for equipment shall be hot dip galvanised.

1.19.3 Fastening methods shall employ **REDHEAD** or **RAMSET** anchor bolts, or their equivalent, for fixing supports to the building structure, it not being permissible to utilise gunpowder shot-driven bolts for this purpose, unless approval be obtained.

1.19.4 Pipework supporting holderbats shall be the product of a recognised manufacturer of such equipment, reinforced shop-fabricated saddles or similar devices. On insulated pipework, reinforced shop-fabricated saddles are to be used, up to and including $\theta 300$ pipes. These saddles are to be placed at support points, and are to be clamped around the pipe. The insulation is to be taken to the edges of these saddles, joints are to be sealed, and the necessary vapour seal and reinforcing taken over the complete section. For piping with a diameter of more than 300mm, hardwood inserts consisting of two half-round, machine cut pieces timber shall be clamped around the pipe, insulation being cut away at such points, to allow proper installation of the supports. Wooden inserts shall be of the same thickness as adjoining insulation and 50mm longer than the width of the holderbat support, to permit correct finishing of the insulation and vapour sealing to them.

1.19.5 Cables and flexible pipes shall be supported on Unistrut, or equivalent, perforated galvanised cable trays, manufactured by specialists. Shop-fabricated trays or racks not being acceptable. The cable tray shall be suspended, or bracketed, using suitable mild steel angles.

1.20 **NOISE AND VIBRATION**

- 1.20.1 Particular care shall be taken in the selection, application and installation of all equipment used to ensure that it operates below the maximum allowed noise levels, specified hereof, and with the least vibration possible, all to the full satisfaction of the Engineer.
- 1.20.2 The following measures shall be taken where necessary, whether specifically called for or not, all to ensure quiet, vibration-free operation of the equipment forming part of the air conditioning and ventilation installations.
- 1.20.3 Rectangular ductwork in the vicinity of critical areas shall be provided with internal acoustic insulation.
- 1.20.4 Anti-vibration cuff connections of flexible joints shall be used on ductwork where it joins vibrating equipment such as fans and air conditioning units.
- 1.20.5 Pipework connecting rotating or vibrating machinery shall be provided with anti-vibration flexible joints, all as previously specified.
- 1.20.6 Equipment shall be mounted on vibration isolators of the correct type and selection, dependent upon deflection requirements versus vibrating frequency.
- 1.20.7 Pipework and ductwork shall be suspended, or mounted, using suitable supports with vibrating isolators to prevent transmission of vibration from them to the structure to which they are attached, where necessary only.
- 1.20.8 Suitable sound attenuating devices shall be incorporated within ductwork to reduce airborne noise to acceptable levels, as indicated on the Drawings.
- 1.20.9 If in the opinion of the Engineer, any equipment operates with, or transmits from it, objectionable vibrations or noise above the levels specified for the individual areas, it will be necessary to rectify or replace, such equipment to the full approval of the Engineer at no additional cost to the Owners.

1.21 PAINTING AND CLEANING

- 1.21.1 No untreated metal surfaces shall be permitted on the project. Items which are not galvanised or similarly protected against corrosion shall be painted, as later detailed herein. No equipment, hangers, brackets, etc. , shall be permitted to be delivered on site in unprotected form; they shall be factory-coated with an approved zinc-rich primer coat before despatch from their place of manufacture.
- 1.21.2 Painting shall comprise the following consecutive processes. First thoroughly clean, descale and degrease all surfaces, in accordance with acknowledged good practice, follow with a good coating of approved zinc-rich primer, and finish with two coats of quality high-gloss enamel of an acceptable make. Final finish shall be to the full approval of the Engineer.
- 1.21.3 With the exception of ducting and piping, items with a galvanised finish, such as cable trays, need not be painted, but shall be properly cleaned with a suitable proprietary galvanised iron cleaning fluid.
- 1.21.4 Particular care shall be taken that appropriate primers be used as a basis for painting, and that paint be of high quality manufacture, all to provide a completely satisfactory finish to the approval of the Engineer. It shall be noted that galvanised surfaces are to be treated to ensure proper bonding of paint.
- 1.21.5 Whereas it would not be necessary to paint any ductwork or conduits installed in roof voids, shafts, masonry ducts, etc., or where not normally visible, it is a requirement that such equipment be properly cleaned, treated with two coats of rustproofing paint if not galvanised, or not metal subject otherwise to rust.
- 1.21.6 All equipment on the project shall be colour-coded in accordance with standards recognised in the Republic of South Africa and, where possible, to comply with relevant South African Bureau of Standard Colour Codes. (S.A.B.S. 1091-1975).

General colour coding for the various items of equipment shall otherwise be as follows. The numbers given in the schedule refer to the colour code numbers of S.A.B.S. 1091-1975. (Any alternative colours shall be approved by the Engineer).

All equipment shall be painted in accordance with colour code given and where factory painted items such as the Air Conditioning Units, Cooling Towers and Pumps are not painted a specified colour, they shall be repainted by the Contractor.

Factory painted equipment which is required to be repainted to comply with the specified colour code shall be rubbed down prior to being given two coats of gloss enamel paint, or as required in accordance with the paint manufacturer's recommendations, and depending upon the type of paint applied at the factory.

EQUIPMENT	COLOUR	CODE No . (SABS 1091-1975)
Air Conditioning Units	Cream	C66
Air Handling Units	Cream	C66
Fans - Axial Flow	Silver	-
Pipework - Mains Water	White	G80
Condenser Water	Green	E14
Chilled Water	Blue	E14
Drains and Overflow	Black	-
Copper - cleaned, polished then coated with	Clear Lacquer	-
Ductwork - Supply, Return & Exhaust	Cream	C66
Switchpanels & Control panels	Orange	-
Electric Wiring Trays or struts	Orange	-
Belt Guards	Red	A11
Equipment Bases	Black	-
Supports & Steelwork	Cream	C 66

- 1.21.7 On completion of the installation the Contractor shall clean all equipment properly, remove all superfluous materials from the site, make good black granolithic finished equipment bases with black concrete paint, sweep out Plant rooms and make the Plant completely presentable before calling upon the Engineers to accept the plant after completion of the 'Preliminary Tests'.

1.22 LABELLING AND IDENTIFICATION

- 1.22.1 All equipment shall be labelled and identified using white Traffolite labels having 10mm high black lettering engraved on them; where two similar items exist, they shall additionally be numbered for clarity in identification. Labels shall be neatly bolted to the equipment with brass fasteners.
- 1.22.2 Belt guards and items of plant containing belt driven equipment shall be fitted with a label stating the number of, and the size of the belts for each V-belt drive. The labels shall be of the same type and dimensions and shall be fixed as specified above for all equipment.
- 1.22.3 Designate and identify each automatic control device such as 3-way valve, thermostat, damper motor etc., and fit to each a white Traffolite label having 5mm high black lettering, the label to be bolted to equipment with brass fasteners. Prepare a complete control Diagram of the installation and label with relevant designations mentioned above, all to form part of plant operating instructions which are later mentioned herein.
- 1.22.4 Label pipes with directional arrow neatly stencilled onto finished pipework or in the form of a durable proprietary transfer. Arrows shall be at not more than 5 meter intervals and not less than 100mm long, of good colour contrast to equipment colour background.
- 1.22.5 Identify all Plant rooms as 'Air Conditioning' or 'Air Handling Plant Room' with 5mm thick engraved P.V.C. sheet notices having 25mm high black lettering on a white background.
- 1.22.6 Provide and install all necessary notices required in terms of 'Governmental and Local Authorities' laws, such as "No Entry to Unauthorised Persons", at all Plant room entrance doors, etc. Such notices to be silk screened onto 3mm thickness P.V.C. sheet, as obtainable from Messrs Mine Safety Appliances.
- 1.22.7 All labels and identification designations shall correspond to the numbers/labels as specified on the drawings and in the plant operating instructions.

1.23 COMMISSIONING AND TESTING - PRELIMINARY TESTS ON COMPLETION

- 1.23.1 Following completion of the Works, or any portion of the Works as specified or directed by the Engineer, the Contractor shall balance, set and test the Works or portion of the Works, in accordance with the following requirements, to establish the capacity and satisfactory performance of the Plant.
- 1.23.2 All balancing, setting and testing shall be done by the Contractor entirely at his own expense. The Contractor shall provide all facilities and apparatus for the testing of the Plant, and shall carry out such tests as may be necessary to satisfy the Engineer that the Plant meets with the requirements of the Specifications.
- 1.23.3 The Contractor shall also carry out, or attend upon, all tests required by Government and Local Authorities who have jurisdiction over the Works, and shall obtain all necessary certificates of approval and acceptance, and shall provide the Engineer with triplicate copies of all such certificates prior to, or at such time as providing the Engineer with copies of his "Preliminary Test" report.
- 1.23.4 All test instruments shall be checked for accuracy by the manufacturer's, supplier's or approved laboratory, and certified copies of certificates showing the degree of accuracy shall be supplied to the Engineer together with the "Preliminary Test" reports.
- 1.23.5 Gauges, thermometers, ammeters and other instruments specified as part of the permanent Plant may be used for test purposes, providing that the Contractor ensures that all such instruments are accurately calibrated. The Contractor shall check the accuracy and calibrate all such instruments against laboratory tested instruments.
- 1.23.6 The Contractor shall when required, provide the Engineer with equipment selection and performance data for all major items of plant, such as Air Conditioning Units, Air Handling Units, Cooling Towers, Pumps, Fans and Sound Attenuators.
- 1.23.7 The Contractor shall keep full and proper written records of all tests conducted and commissioning information, such data to be properly indexed and clearly set down to form part of the Operating and Maintenance manuals called for in the Specification.
- 1.23.8 The Engineer reserves the right to inspect any item of equipment during manufacture or before delivery to site. The Contractor shall make available any item for such inspection.
- 1.23.9 Electrical switchpanels shall be inspected by the Engineer at their place of manufacture, prior to delivery to Site. At such inspection and testing, the Contractor shall demonstrate the functioning of the switchpanel to the Engineer. Any defects in materials, finishes and operation of the switchpanels shall be corrected at their place of manufacture, prior to delivery to site.
- 1.23.10 The Contractor shall, on handing over the installation or any portion thereof to the Engineer, also provide the necessary certificates as proof of having conducted a satisfactory electrical test to the requirements of the electricity supply authority, such certificate emanating from such authority, and permitting full use to be made of the installation without the need for further tests.
- 1.23.11 The Contractor shall properly test and call for inspection by the Engineer, any work which is to be covered, concealed, built-in, otherwise closed up or rendered inaccessible, before such closing up takes place. The Engineer may require any work of this nature which he has not been called on to inspect before closing up, to be uncovered or made accessible, entirely at the Contractor's expense, making good included.
- 1.23.12 Prior to the "Final Tests" to be attended by the Engineer, the Contractor shall balance, set and test the following to establish the capacity and performance of the Plant. All such "Preliminary Tests" shall be recorded by the Contractor, who shall provide the Engineer with three typed copies of all test recordings which shall set out procedure, data and instrument readings obtained, as compared with the specified capacities and the manufacturer's name plate ratings where applicable. Such "Preliminary Test" reports shall be accompanied by one preliminary draft set of Operating and Maintenance Instructions prepared in accordance with the requirements as detailed herein.

- 1.23.13 On receipt of an acceptable preliminary test report and draft copy of the Preliminary Operating and Maintenance Instructions, the Engineer shall advise the Contractor in writing so that he may arrange for the "Final Test" and issue of the Acceptance Certificate\.

THE "PRELIMINARY TESTS" SHALL INCLUDE THE FOLLOWING:

- 1.23.13.1 Drains shall be tested for proper functioning by pouring water down them at a rate of at least four times normal drainage.
- 1.23.13.2 Field assembled refrigerant piping and apparatus shall be tested with dry carbon dioxide or nitrogen, plus a small amount of refrigerant. Test procedures shall be in accordance with the latest edition of the American Standard Safety Code for Mechanical Refrigeration. Leaks in pipe joints shall be corrected by remaking the joints. Caulking will not be permitted. The vacuum test shall follow the pressure test.

Charging of the equipment with refrigerant shall follow the vacuum test as closely as is practicable to minimise the possibility of air, or moisture, being returned to the system. After charging and prior to capacity tests, joints in refrigerant piping and apparatus shall be checked with a halide torch or other equally sensitive leak detector. If leaks are found, the system shall be pumped down and the leaks corrected.

- 1.23.13.3 Capacities of Air Conditioning Units, Fans and other equipment shall be determined by operating tests of not less than four hours duration, after stable conditions have been established. Test procedures shall be in accordance with applicable portions of **ASME** and other recognised test codes, as far as field conditions permit. Capacities shall be based on temperatures and air quantities measured during such tests.

Temperature differences required for determining capacities shall be measured by thermometers having graduations that permit interpolations having an accuracy of $\pm 0,5^{\circ}\text{C}$.

Air quantities may be measured by Pitot tube, anemometer or velometer, depending on the velocity and other conditions of flow.

Check alignment of all equipment drives prior to setting into operation.

- 1.23.13.4 Air systems shall be checked for obstructions, and balanced to provide the required air quantities at each outlet, without objectionable noise and draughts, and so that the velocity of the air is relatively uniform over the area of the outlet.

Velocity meters may be used to test all outlets and for duct velocities up to 1,5 m/s, above which velocities shall be measured with Pitot tubes. Properly capped openings shall be provided in ducting as required. Final setting of all volume adjusting devices shall be permanently marked.

Should it be necessary to re-balance any air system due to partitioning or repartitioning of the conditioned space after the specified conditions have been obtained and accepted by the Engineer in writing, then such re-balancing shall be carried out as an extra to the Sub-contract and shall be authorised, by the issue of a "Variation Order", by the Engineer.

- 1.23.13.5 All automatic controls and safety devices shall be checked for correct performance and satisfactory operation, and set to the respective settings required.
- 1.23.13.6 All electrical switchpanels shall be checked for the correct functioning of all components, electrical interlocks, all time clocks, time delay relays and automatic control devices shall be set for their correct function.
- 1.23.13.7 The full load running current of all electrically operated equipment shall be recorded and compared with the manufacturer's name plate ratings, which shall be recorded, together with any other relevant data stamped on the name plates. All overload protection devices shall be set to the correct values, which shall be recorded.

1.23.13.8 The Contractor shall ensure that the plants operate satisfactorily and uninterrupted for a period of 7 days prior to the final acceptance by the Engineer. Evidence of this, for air conditioning systems, shall be given in the form of a 24 hour long, continuous recording of temperature and humidity, which recording shall cover at least 50% of the areas handled by any one plant and shall be handed over to the Engineer prior to inviting him to the "Final Tests" and acceptance of the completed installation.

The original recorded graphs shall be supplied to the Engineer, and the Contractor shall also obtain and provide the Engineer with the daily maximum dry and wet bulb temperature readings recorded in the area, on the same days as the inside conditions are recorded. Such information may be obtained from local weather stations.

1.24 OPERATING AND MAINTENANCE INSTRUCTIONS

1.24.1 The Contractor shall furnish to the engineer before the Works are taken over, such Operating and Maintenance Instructions, together with Drawings of the Works as completed, and in sufficient detail to enable the Employer to operate, maintain, dismantle, re-assemble and adjust all parts of the Works.

The Works shall not be considered to be completed for the purpose for taking over until the required Instructions and Drawings have been supplied to the Engineer.

1.24.2 A draft copy of all written instructions shall be submitted to the Engineer for approval together with the required copies of the "Preliminary Test" report, as previously specified herein, prior to the preparation of the final copies.

THE "OPERATING INSTRUCTIONS" SHALL INCLUDE THE FOLLOWING:

1.24.3 Instruction Manuals comprising the following sections bound in a blue coloured vinyl plastic covered folder, with the name of the project typewritten on a card inserted into a clear plastic covered cardholder on the front cover.

1.24.3.1 INDEX (in detail)

1.24.3.2 DESCRIPTION OF PLANT (as installed)

1.24.3.3 OPERATION OF PLANT (as installed) to include:

- Automatic and manual start-up and shut-down procedure.
- Operation and Sequence of all automatic controls.
- Scheduled description of all Control and Safety Instruments; listing function, make, model number, range and differential (when applicable), and setting of each instrument.
- Functions of all switches, indication lamps, reset buttons and alarms; and instructions for adjusting and re-setting all controls and cut-out switches.

1.24.3.4 PLANT AND EQUIPMENT

Scheduled list of all major plant and equipment to include Description, Make, Model Number and supplier's name and address.

1.24.3.5 TEST REPORT

Copy of "Final Test" report as accepted by the Engineer. (Draft copy of "Operating Instructions" for Engineer's approval shall contain a copy of the "Preliminary Test" report.)

1.24.3.6 MAINTENANCE INSTRUCTIONS

In schedule form setting out each item of plant, and the description as necessary for preventative maintenance of the Plant as installed.

1.24.3.7 SPARE PARTS

List of spare parts supplied (in accordance with these Specifications), with detailed description of each part, make, model or part number and Supplier's name and address.

1.24.3.8 DESCRIPTIVE LITERATURE

To include manufacturer's operating and maintenance instructions, performance curves or charts and spare parts lists where applicable, and where available.

1.24.3.9 DRAWINGS

List of all Drawings and photographically reduced, Size A3, copies of all "as installed" Drawings and Diagrams to include the following:

Plant layout Drawings showing the actual positions and sizes of all plant and equipment, ducts, pipes, the location of all dampers, valves and controls, and the measured air quantities at all air intake and discharge points.

Control and Wiring Diagrams and Schematic Piping Diagrams noting, where applicable, the normal and abnormal gauge readings, control points, scale settings and time settings, differential bands, throttling ranges, time relays and the overload settings and actual rated amperages of all electrical components, and any other relevant variable and adjustable items, to permit checking and adjustments, controls and motor functions.

1.24.3.10 COPIES OF INSTRUCTIONS IN PLANT ROOMS

As required in compliance with Government and Local Regulations.

1.244.4 A copy of the "Operation of Plant" instructions shall be mounted within a glazed or plastic covered frame in the Plant rooms, in positions to be approved by the Engineer.

1.244.5 Copies of the Schematic Piping Diagrams and the Control and Wiring Diagrams shall be mounted within glazed or plastic covered frames in the Plant rooms in positions to be approved by the Engineer.

1.24.7 The Contractor shall instruct the Employer's personnel in the correct operation and use of the Plants. For this purpose the Contractor shall allow for the time of a competent instructor for a total of four hours on Site, and one return trip to the Site for the purpose of providing such instruction.

1.24.8 During this period the Contractor shall fully explain the layout, operation and maintenance of the plant to the Employer or the Employer's Representative.

At the conclusion of this period of instruction the Contractor shall obtain from the Employer an acknowledgement, in writing, that the instruction has been properly given for the prescribed period. Two copies of the acknowledgement shall be forwarded to the Engineer.

1.24.9 The Contractor shall supply the Employer or Tenant with a plant log book that will reflect all call-out or routine service visits.

1.25 MAINTENANCE

- 1.25.1 The Contractor shall maintain and service the Plant, in accordance with the following requirements for a period of twelve months calculated from the date of the "Acceptance Certificate" or, in the event of more than one certificate having been issued by the Engineer, from the respective dates so certified.
- 1.25.2 During the "Maintenance Period" the Contractor shall maintain and service the Plant regularly at monthly intervals, and make good any Defects in accordance with the provisions of these Specifications.
- 1.25.3 The Maintenance of the Plant shall be carried out during normal working hours and at each service the Contractor shall attend to the following: -
- 1.25.3.1 Report to an official nominated by the Employer on arriving and again on leaving the Works. Such person shall complete and sign the monthly "Service Report".
- 1.25.3.2 Check the function of each item of the Plant including all automatic controls and safety devices, for correct operation and lubrication, adjust, clean and/or replace components and ancillaries as necessary.
- 1.25.3.3 Clean all washable air filters, and check all disposable media type air filters serving the air conditioning plants, for pressure drops, fitting additional filter material, if required.
- 1.25.3.4 Check all refrigeration systems for leaks, refrigerant dryness, sufficient oil in the compressors, sufficient refrigerant gas or any other defect.
- 1.25.3.5 Check the electrical switchpanels replacing any burnt contacts or pilot lamp bulbs which have failed.
- 1.25.3.6 Take and record Wet and Dry Bulb temperatures in each of the conditioned areas and outside. Temperature readings shall be taken with a reliable sling psychrometer, and all readings shall be recorded on the "Service Report".
- 1.25.3.7 Attend to any complaints made with respect to the Plant, by the official nominated by the Employer's, being the only person authorised to instruct the Contractor or make any complaint, (other than the Engineer.) No other person shall have any right to instruct, or make any complaint to the Contractor.
- While attending to any Defects and the Servicing of the Plant, the Contractor shall not unduly disturb the functions of the occupants in the areas concerned.
- 1.25.3.8 The one year maintenance period shall commence on the date of the issue of the "Acceptance Certificate". The first service to take place 1 month after date of "Acceptance Certificate". The Contractor shall notify the Engineer and Client in writing, 14 days prior to this service, so that the Engineer and the Client's Representative may be present during the services.
- 1.25.3.9 It is an explicit condition of this enquiry that all work carried out in pursuance of this tender enquiry will be guaranteed against failure, or defect whatsoever, for a period of 12 months from the time of Acceptance by the Client.

Any costs for labour, materials, etc., which the Contractor incurs whilst maintaining the above guarantee for the specified period shall be borne by the Contractor.

1.26 **DRAINS**

- 1.26.1 Provide all necessary drain piping, laid to suitable falls, from every item requiring such drainage. Such drains shall be run to the adjacent relevant drain points shown on the Drawings.
- 1.26.2 Drainage pipework shall be adequately sized and carried out generally in medium grade galvanised piping, all connections to equipment being effected with conical faced unions or flanges.
- 1.26.3 All drains from cooling coil pans for condensate disposal shall be fitted with proprietary U-traps to prevent backflow, or non-drainage due to negative air pressures.
- 1.26.4 Drainage pipework of longer than 4,5m run shall be provided with cleaning eyes on all bends to facilitate maintenance.

1.27 **EXCLUSIONS**

- 1.27.1 The Tendered price shall specifically be understood to **INCLUDE** all the following items, it being stressed that such items will be provided by others to details given by the successful Tenderer, and approved in writing by the Engineer.
- 1.27.2 The provision and making good of any openings required through walls, floors, ceilings and roofs, as well as any timber framing or flashing necessary for same.
- 1.27.3 All concrete work associated with the provision of equipment bases as detailed herein.
- 1.27.4 Any item, comprised of timber, bricks, mortar or concrete which can reasonable be construed as builder's work, together with the building-in of any item required.
- 1.27.5 The architectural concealment of any equipment to be installed by the successful Tenderer. This would apply particularly to piping and ducting.
- 1.27.6 The provision of masonry shafts as shown on the Drawings, complete with smooth internal plastered finish.
- 1.27.7 All openings in glazing in windows for the installation of exhaust fans.
- 1.27.8 The provision of mains water supply points, each terminating in a gate type isolating valve within three meters of the equipment it serves, as indicated on the attached Drawings.
- 1.27.9 Drainage points will be provided in the positions, and of the sizes indicated on the Drawings, such drains for general equipment drainage and condensate disposal.
- 1.27.10 The bringing up, and connecting to, the incoming terminals of the main isolators in each switchpanel of suitably rated 380 volt, 3 phase 4 wire electricity supplies, in the positions indicated on the drawings. Suitably rated 380 volt, 3 phase, 4 wire electricity supplies to any remote fans or equipment in the positions indicated on the drawings. Suitably rated 220 volt, single phase switched socket outlets for propeller type exhaust fans in the positions indicated on the Drawings.
- 1.27.11 Any other item mentioned in these Specifications, or on the accompanying Drawings as being expressly for the provision of others.

PART TWO

DETAILED SPECIFICATION

PART TWO

DETAILED SPECIFICATION

<u>CLAUSE</u>		<u>PAGE NUMBERS</u>
2.1	INDEX	1
2.2	Scope of Works	2
2.3	Programme	3
2.4	Design conditions	3
2.5	Noise and vibration	3
2.6	Plant duties	4
2.7	Drawings	4
2.8	Description of the air conditioning system	4-5
2.9	Air handling units	7-9
2.10	Automatic control system and BMS	9-27
2.11	Design criteria	28
2.12	Schedules	29
2.13	Materials and Labour Rates	30-31

2.2 SCOPE OF WORK

2.2.1 The Contract, as detailed in these Specification Documents and the accompanying Drawings, comprises of the manufacture, supply, transport and delivery, hoisting, installation, testing, setting in operation, leaving in complete working order, and guarantee of the entire air conditioning plant and, except so far as the contract otherwise provides, the provision of all labour, materials, contractor's equipment and everything, whether of a temporary or permanent nature required in and for such manufacture, supply, offloading, hoisting, installation, testing, setting in operation, leaving in complete working order, guarantee so far as the necessity for providing the same is specified in or reasonably to be inferred from the contract.

2.2.2 Builder's Work shall be included in this contract and all such work, as later herein specified as being specifically included from this contract, shall be carried out the contractor as applicable and as provided herein.

2.2.3 Work by Contractor:

- All equipment plinths, bases and plant rooms. Metal plinth formers to be provided by HVAC Contractor.
- All plant enclosures
- All penetrations through walls, slabs, ceilings and steelwork
- Making good of all openings after installation of ductwork and equipment
- Waterproofing of all duct or piping entries to building through roofs, walls or the structure
- Cut outs in doors and installing door grilles supplied by Air Conditioning Contractor

NOTE: Ceiling panels must be removed by Air Conditioning Contractor.

- Water supply points terminating in valves
- Drain points. Galvanised steel drain piping to drain points must be provided by the HVAC Contractor.
- All as indicated on drawings.
- Mains incoming power supplies to the main air conditioning boards.
- Emergency power change over contactors, wiring to air conditioning plants and change over signal
- Wall boxes and conduit in brick walls or partitions for air conditioning controls
 - HVAC contractor to confirm all conduit and box sizes required.
- All as shown on drawings.
- Emergency power and fire signal to all smoke ventilation fans. HVAC contractor to provide all starters, wiring and manual test facility for each fan.

NOTE:

1. All final terminations in the air conditioning panels by the air conditioning contractor.
2. All air conditioning panels to be "top-entry" type.
3. Power distribution from air conditioning plant room distribution boards to AC units and fans is by the air conditioning Contractor.
4. All final connections between local isolator's outdoor units and ventilation fans by the Air Conditioning Contractor.
5. All site wiring between outdoor and indoor units including controls by Air Conditioning Contractor.

POWER SUPPLY ON SITE

1. Voltage: 400/230V \pm 5
2. All AC Electrical Panels Fault Levels of 10 kA (Unless stated otherwise)

2.3 PROGRAMME

2.3.1 The tenderer shall execute these contract works strictly in accordance with the programme dates.

The entire air conditioning and ventilation installation must be commissioned, tested and taken over by the Engineer before practical completion:

2.3.2 The contractor shall be required within ONE WEEK after acceptance of his Tender, to submit to the Engineer for his approval a Programme showing the order in which the Works will be executed. Such programme shall show the times for the preparation of all drawings, ordering and delivery times promised by the suppliers for each major item of Plant, manufacturing and delivery times for all manufactured items, installation times and the programmed dates for testing and commissioning the Plant. The programme is to indicate the times required for all the electrical, builder's and plumbing work.

The contractor shall submit TWO copies of his Programme to the Engineer for approval.. After submission to and approval by the Engineer of such Programme, the contractor shall adhere to the order of procedure and method stated therein unless he obtains the written permission of the Engineer to vary such order or method. The submission to and approval by the Engineer of such Programme shall not relieve the contractor of any of his duties or responsibilities under the contract.

2.3.3 The times required for the submission of Drawings are as follows:

Shop Drawings within **ONE WEEK**

2.4 DESIGN CONDITIONS

The Engineer's design for the air conditioned areas has been based on the following Ambient Conditions, whilst maintaining the specified Internal Conditions.

Ambient Temperature	- Summer	: 37°C Dry Bulb 22°C Wet Bulb
	- Winter	: 2.1°C Dry Bulb
Internal Areas 1.5°C	- Summer	: 22°C Dry Bulb ±

2.5 NOISE AND VIBRATION

Noise levels caused by the operation of the air conditioning / ventilation equipment shall not exceed 60Dba when measured at a distance of 1.5m from any grille or diffuser.

The sound attenuator currently installed on the supply air ducting of AC 1 will be re-used.
All equipment shall, in any event, be selected for the quietest possible operation.

Not transmission of vibration to the structure, or elsewhere, caused by the operation of the air conditioning or ventilation equipment, will be permitted. All sound absorbing and / or anti vibration materials or devices as are necessary to ensure a satisfactory degree of silence and absence of the transfer of vibration to the structure shall be included in the tender price.

2.6 PLANT DUTIES

The duties of all plant and equipment are indicated on the drawings. No plant shall have capacity of less than that indicated.

Tenderers shall note that fan pressures where indicated, are given for tendering purposes only, and selections shall be made to suit the losses of the system and the particular equipment offered.

2.7 DRAWINGS

2.7.1 Tender Drawings

The Drawings accompanying this Specification are as numbered below, and shall be deemed to indicate the general layout and requirements only and are not Shop Drawings.

The Engineer shall provide the Contractor, free of charge, with three sets of Specification Documents, to include the Tender Drawing.

DRAWING NUMBER

35129.00-740-01

35129.00-740-02

2.7.2 Architectural and Structural Drawings

The Contractor shall ensure that he is in possession of all information required for the installation of the Works and shall, if necessary, obtain copies of all relevant Architectural and Structural Drawings from the Architect and Structural Engineer, so named elsewhere in this Specification.

2.7.3 Builder's Work Drawings

All Builder's Work and work to be carried out by others in accordance with the Specification has been indicated on the Tender Drawings. The Contractor shall check, approve, add to or alter such drawings as may be necessary to suit the Plant offered by him, and accepted by the Engineer, within the time stipulated in Clause 5.3.4 on Page V/3 hereof from date of acceptance of his Tender and shall submit to the Engineer in duplicate any revision which shall be made to such Drawings.

Such Builder's Work Drawings shall indicate the location and extent of all foundations, bases, openings, timber frames and all other Builder's Work and the capacities and/or dimensions of all electrical and water supply points, the method of terminating such supplies and the position of the connection points, the position and dimensions for all water drainage connections and any other work to be provided by others for the Works, as detailed in these Specifications.

The Drawings shall be drawn to scale and in sufficient detail to enable the Builder to execute the work without any misunderstanding.

Within a reasonable period after receiving such Drawings, the Engineer shall signify his approval, or otherwise, and one signed copy of the approved Drawing shall be returned to the Contractor.

When approved, the following number of copies of each such Drawing shall be delivered to each of the following:

Contractor	3 copies
------------	----------

2.7.4 Shop Drawings

The Contractor shall submit to the Engineer, for approval within the time stipulated and duplicate copies of all Shop Drawings as required for the manufacture and installation of the Works or as the Engineer may reasonably require.

All Shop Drawings for work outside of plant rooms shall be drawn to a scale of not smaller than one in fifty and all Drawings of work within plant rooms shall be drawn to a scale of not smaller than one in twenty-five. All details shall be drawn to a scale to show the detail required.

Within a reasonable period after receiving such Drawings, the Engineer shall signify his approval, or otherwise, in writing and one signed copy of each approved Drawing shall be returned to the Contractor.

The Contractor shall not, unless otherwise directed by the Engineer, in writing, commence with any work prior to the approval of the relative Shop Drawings. Work installed prior to the approval of Shop Drawings shall be liable to rejection by the Engineer and removal and/or replacement by the Contractor, at his cost, if it is considered by the Engineer to deviate from the Specification.

The Contractor shall also supply copies of all approved Drawings in accordance with the requirements of the Operating and Maintenance Instructions of the Specification.

Drawings approved as above described shall not be departed from except as authorised by the Engineer.

The Engineer shall have the right at all reasonable times, to inspect at the factory of the Contractor, all Drawings of any portion of the Works.

2.7.5 Mistakes in Drawings

Any expense resulting from an error or omission in or from delay in delivery of the Drawings, shall be borne by the Contractor.

The Contractor shall be responsible for any discrepancies, errors, or omissions in the Drawings and other particulars supplied by him, whether such Drawings and particulars have been approved by the Engineer or not, provided that such discrepancies, errors, or omissions are not due to inaccurate information or particulars furnished in writing to the Contractor by the Engineer or the Architect. The Employer shall be responsible for Drawings and information supplied in writing by the Engineer or the Architect and for the details of special work by either of them.

2.8 DESCRIPTION OF THE AIR CONDITIONING SYSTEM

The system will consist of the installation of DX hybrid package units to replace the existing chilled water air handling units.

2.8.1 ELECTRICAL INSTALLATION

Tenderers must include pricing for all electrical boards, sub boards and wiring.

All ACDB's are to be weather proof.

All conduits / wireways to be galvanized steel.

2.8.1.1 ELECTRICAL SWITCHBOARDS AND WIRING

Electrical switchboards shall be constructed and wiring carried out in accordance with Part IV of this specification and the electrical schedules which form part of this documentation.

All switchboards shall be pre-wired and tested prior to delivery to site.

Switchboards shall be wired in such a way as to provide safe sequenced and automatic start up and operation of the systems. All necessary interlock and time delay relays etc. are to be allowed in the price.

The main offer shall be based on the use of YASKAWA IP 65 variable speed drives for the AHU or OHU supply fan motors. The VSD cannot cause the fan to whine.

Alternatives may be offered under separate cover.

All wiring from the air conditioning switchboards to all individual components of the air conditioning and ventilation systems is to be carried out as part of the air conditioning contract.

Tenderers are to allow in their price for 10% spare capacity on the number of outlets served by each switch panel.

It should be noted that this building has a standby generator. Allowance should be made in the tender for sequence starting of all equipment to avoid tripping of emergency equipment.

All ACDBs to have the following installed:

- Volt meter.
- Ammeter.
- Selector Switch
- Fire Interlock

Switch gear for all fans to include the following:

- Ammeter
- Manual/Auto/Off switch.
- Run & fault lights.

Switch gear for all AHU's to include the following:

- Manual/Auto/Off switch.
- Run & fault lights.
- Variable speed drives.
- Air Pressure Switches

Essential Boards to be as follows:

- | | |
|-------------------------|--------------------------|
| • System: | 400V/3 Phase/4 Wire |
| • Fault Level: | 10 kA |
| • Incoming cable entry: | Top |
| • Outgoing cable exit: | Top |
| • Panel access: | Front |
| • Labels: | English |
| • Control Wiring: | 1,5 mm ² |
| • Construction: | 2 mm Sheet metal (3CR12) |
| • Paint Finish: | Red |

Non-Essential Boards to be as follows:

- System: 400V/3 Phase/4 Wire
- Fault Level: 10 kA
- Incoming cable entry: Top
- Outgoing cable exit: Top
- Panel access: Front
- Labels: English
- Control Wiring: 1,5 mm²
- Construction: 2 mm Sheet metal (3CR12)
- Paint Finish: Orange

2.8.2 CO2 SENSORS

Measuring Range	0 to 2 000 ppm CO2
Accuracy at 25 °C	±[50 ppm + 3.0% of reading] (includes calibration uncertainty, repeatability and non-linearity). All accuracy specifications reflect the testing of the transmitter using high-grade certified gases. The transmitter is intended for an altitude range of (0 to 600 m) above sea level without compensation
Temperature Dependence of Output	-0.35% of reading/°C, typical (may vary between individual units)
Long-Term Stability	<5.0% of full Scale/5 years
Response Time (0 to 63%)	1 Minute
Operating Temperature Range	F-5 to 45°C
Storage Temperature Range	F-20 to 70°C
Humidity Range	0 to 85% RH (noncondensing), 29°C maximum dew point
Transmitter CO2 Output signal	4 to 20 mA or 0 to 10 VDC Maximum Output Current: 25 mA: Maximum Output voltage: 23.5V
Resolution of Analog Outputs	2.5 ppm CO2

2.9 **AIR HANDLING UNITS**

Air conditioning units shall be a hybrid type system consisting of a vertical discharge indoor air handling unit incorporating a DX cooling coil and matched with a set of suitably selected VRF outdoor units.

The indoor air handling unit shall be Thermopak series incorporating variable speed EC motor plug supply air fans. Fans shall be provided with fan guards and inlet screens.

Cooling coil shall be copper tube with aluminium fins in a Grade 304 stainless steel. To provide maximum dehumidification the coil shall have at least 10 rows.

Filter frames shall be Grade 304 stainless steel.

Condensate drip tray shall be constructed of 1.2 mm Grade 304 stainless steel and shall be at least 55 mm deep.

The VRF outdoor units shall be LG or equal.

Each outdoor unit shall be an inverter type thus enabling variable capacity (refrigerant volume flow) to suit the instantaneous capacities of the indoor unit. Outdoor units shall be air cooled, with vertical discharge.

Outdoor units shall be fixed to hot dipped galvanized steel channels (with Anti Vibration mounts) placed on top of the existing concrete plinth as indicated on the drawings. All steel, equipment supports, shall be provided by the HVAC Contractor.

All refrigerant piping shall be Refrigerant and Air conditioning grade copper tubing, annealed coils up to 19.05 mm and hard drawn straight lengths for 22.33 mm and larger. All tubes are to be thoroughly degreased, nitrogen filled and tube ends capped during installation to prevent ingress of moisture and dirt.

Wall thickness shall be selected for R410A refrigerant design pressure of 5.8 MPa.

All joints and fittings shall be made strictly in accordance with the manufacturer's instructions. All parts shall be carefully cleaned before jointing. Nitrogen shall be passed through pipes while soldering work is carried out.

Tenders shall note that the Engineer reserves the right to request that two refrigerant pipe joints be cut out and inspected by others to verify that the above has been complied with.

Before charging with refrigerant the system shall be purged of air and a vacuum held for 24 hours to ensure moisture removal. Equipment manufacturer's instructions and normal industry standards shall be adhered to at all times.

All joints (for branches) shall be as supplied by the VRF System supplier. Joint insulation shall be pre-formed, obtained from the joint supplier. Refnet joint insulation shall be neatly connected and glued onto the insulation material of the adjacent refrigerant piping, using a glue of adequate strength.

The HVAC Contractor shall certify in writing that all refrigerant piping installed meets with the technical specification and recommendations of the air conditioning equipment manufacturer. Piping shall be inspected by the Air Conditioning unit manufacturer's representative.

The refrigerant pipe circuits (before connection to the outdoor units) are to be pressurized to 4MPa and left to stand for 24hours. The circuits shall be considered satisfactory if during this time the pressure does not become reduced.

Refrigerant pipes shall be insulated with convectonal closed cells neoprene

Refrigerant pipes shall be insulated with convectonal closed cell neoprene rubber sheathes, minimum 10mm thick. Cut ends shall be glued together. All gas pipes and liquid pipes shall be individually insulated.

All piping shall run in cable tray, Cabstrut Medium Duty or equal, of galvanised perforated plate construction. Sizes shall be selected to suit the refrigerant piping.

Piping shall be fixed to the cable tray by means of cable ties with a section of galvanised sheetmetal wrapped around the pipe to prevent over tightening of the cable tie.

Uninsulated copper piping shall not touch any galvanised surfaces e.g. cable tray etc. PVC or rubber spaces shall be provided.

Pipework exposed outdoors shall be provided with galvanised steel covers, painted brown to match existing, to prevent deterioration of the insulation by exposure to the sun.

The control panel forming part of the AC 1 system shall be manufactured by the air handling unit manufacturer who shall take full responsibility for the integration of the system including VRF components with cooling coil functioning.

Due to space constraints inside the plantroom, the control panel shall form an integral part of the air handling unit and not be free standing.

The VRF outdoor unit suppliers shall inspect the completed installation and commission the VRF units on site. Written confirmation from the VRF supplier after site commissioning shall be submitted to the Engineer.

The AC 1 control panel shall be painted RED and controls shall include the following:

- Main Isolator (Essential Power)
- Supply air fans control
- VRF TX value controls
- Programmable digital controller
- Gas detection system interface
- Interface to switch system OFF if Collection Area goes into evacuation mode
- Auto restart after power failure
- ON/OFF Auto switch. On Auto the system must accept a signal from the BMS system for ON/OFF switching.
 - BMS interface of:
 - Return air temperature
 - Fan ON/OFF status
 - Filter dirty alarm
 - Air flow status
 - Trip alarm
 - Pilot lights for Power On (yellow), Fans run (green) and fans trip (red).

The control panel shall also include an electric display/set point adjustor, on the outer face of the door. This shall display set point temperature, actual temperature and provide means to adjust set point temperature.

Each item of equipment in the panel, or projecting through the door is to be labelled, indicating its function, by means of engraved plastic labels, screwed or pop riveted in position.

All wiring and cables shall be clearly labelled using proprietary cable labelling systems.

A wiring diagram of the control panel is to be provided and fixed to the inside of the door.

All terminals are to be numbered on the diagram.

The unit shall be set to operate at a room temperature of 18°C.

The unit shall be required to operate 24 hours per day throughout the year.

Heating is not required.

The indoor unit shall utilize the plant room as a return air plenum.

The Air Conditioning Contractor shall provide all refrigerant piping and condensate drain piping to the extent indicated on the drawings.

Drains shall be provided with suitable P traps.

The Air Conditioning Contractor shall supply and install a weatherproof lockable isolator adjacent to the outdoor VRF condensing units and a power supply to the indoor unit control panel as well as the interconnection cables to the HVAC Control Panel located in the Ground Floor plant room as indicated on the drawings. Interconnecting

2.10 AUTOMATIC CONTROL SYSTEM AND B.M.S.

2.10.1 Tenderers shall base their main offer on the use of controls by Johnson Controls.

Alternatives may be offered for the following systems:-

LANDIS AND STAEFA

ALERTON HONEYWELL

The final detailed design, supply, installation, wiring and commissioning of the control system shall be carried out by the specialist controls company. Note all conduits / wire ways to be galvanised steel.

2.10.2 GENERAL SPECIFICATION

The Heating ventilation and air conditioning Contractor shall employ a Controls Specialist Company who is well established in South Africa, is reputable and who shall be responsible for the design, engineering, documentation, supply, installation, commissioning, hand over, guarantee and maintenance of the BMS (Building Management System) and to implement the sequence of operation as shown on the drawings. This Controls Specialist Company shall hereinafter be shown as the BMS Contractor.

The Contractor's main tender offer shall be based on Johnson Control BMS system. Prices of alternative systems may be offered for consideration.

Work includes

A Basic Requirements:

1. BMS Contractor shall provide: -
 - a. A fully integrated building management system (BMS), preferable UL listed, incorporating direct digital control (DDC) for energy management, equipment monitoring and control, including colour graphic workstation.
 - b. Complete temperature, pressure etc. control system to be DDC as specified herein.
 - c. All wiring, conduit, panels for all temperature, humidity, pressure, etc. controls.
 - d. All final electrical connections to each stand-alone Application Specific controller and DDC Controller. Pick up power from the nearest MCC (A/C Motor Control Centre) of A/C DB (Electrical Distribution Board).
 - e. BMS Contractor shall be responsible for all electrical work associated with the BMS control system and as called for on the Drawings.
 - 1) Perform all wiring in accordance with all local and national codes. In particular:
 - a) SABS codes of Practice for Wiring of Premises.
 - b) The Occupational Health and Safety Act.
 - c) National Building Regulations Specifications and Codes of Practice issued by the SABS and British Standard Institute.
 - 2) The HVAC contractor shall provide 220 volt, 10 amp circuits and circuit breakers from normal and/or emergency power panels for the DDC systems.
 - 3) Surge transient protection shall be incorporated in the design of the system to protect electrical components in all DDC Controllers, Application Specific Controllers and operator's workstations.
 - 4) All low voltage control wiring throughout the building whether exposed or concealed shall be run in steel conduit. Any exceptions must be approved by the Engineer prior to installation.

2. The HVAC Contractor will provide.
 - a. The installation of all wells and openings for water monitoring devices such as flow switches, flow sensors etc as required by the BMS contractor.
 - b. Installation of control valve bodies.
 - c. All package unit and chiller controls.
 - d. Installation of damper actuators and ensure free movement of these dampers.
 - e. Installation of smoke dampers; outdoor air, exhaust air and vent dampers; with adjacent access doors where required.

- B. General Product Description:
 1. The building management system (BMS) shall integrate multiple building functions including equipment supervision and control, alarm management, energy management and historical data collection.
 2. The building management system shall consist of the following:
 - a. Stand-alone DDC Controllers.
 - b. Stand-alone Application Specific Controllers (ASCs).
 - c. Portable operator's terminal(s).
 - d. Personal computer operator workstation(s).
 3. The system shall be modular in nature and shall permit expansion of both capacity and functionality through the addition of sensors, actuators, DDC Controllers, Application Specific Controllers and operator devices.
 4. System architectural design shall eliminate dependence upon any single device for alarm reporting and control execution. Each DDC Controller shall operate independently by performing its own specified control, alarm management, operator I/O and data collection. The failure of any single component or network connection shall not interrupt the execution of control strategies at other operational devices.
 5. DDC Controllers shall be able to access any data from, or send control commands and alarm reports directly to, any other DDC Controller or combination of controllers on the network without dependence upon a central processing device. DDC Controllers shall also be able to send alarm reports to multiple operator workstations without dependence upon a central processing device.

Quality Assurance

- A. Materials and equipment shall be the catalogued products of manufacturers regularly engaged in production and installation of automatic temperature control systems and shall be manufacturer's latest standard design that complies with the specification requirements.

Locally produced substitutes may be offered only as alternatives to the main offer.

- B. Install system using competent workmen who are fully trained in the installation of temperature control equipment.
- C. All electronic equipment shall conform to the requirements of Governing Radio Frequency Electromagnetic Interference.
- D. Design and build all system components to be fault-tolerant.
 - 1. Satisfactory operation without damage at 110% and 85% of rated voltage and at plus 3 Hertz variation in line frequency.
 - 2. Static, transient and short-circuit protection on all inputs and outputs.
 - 3. Network-connected devices to be A.C. coupled or equivalent so that any single device failure will not disrupt or halt network communication.
 - 4. All real time clocks and data file RAM to be battery-backed for a minimum 72 hours and include local and system low battery indication.
 - 5. It must be possible to receive and print out alarms at a central location even when the operator's workstation at that location is non-operational or taken out of service for periodic maintenance.

Submittals

Before the BMS Contractor is appointed by the A/C Contractor the proposed BMS Contractor must submit a copy of this specification showing whether their system conforms to each clause and if not they must submit a detailed schedule of deviations together with a full description of how their system accomplishes the specific requirement.

The engineer reserves the right to reject the proposed BMS Contractor if there are any deviations to the specification.

PRODUCTS

Networking Communications

- A. The design of the BMS shall network operator workstations and stand-alone DDC Controllers. The network architecture shall consist of two levels, a high performance peer-to-peer network operating at an up to 19 000 baud as well as DDC Controller specific local area networks.
- B. Access to system data shall not be restricted by the hardware configuration of the building management system. The hardware configuration of the BMS network shall be totally transparent to the user when accessing data or developing control programs.
- C. Peer-to-Peer Network Level:
 - 1. Operator workstations and DDC Controllers shall directly reside on a network such that communications may be executed directly between DDC Controllers, directly between workstations and between DDC Controllers and workstations on a peer-to-peer basis.
 - 2. All operator devices either network resident or connected via dial-up modems shall have the ability to access all point status and application

report data or execute control functions for any and all other devices via the peer-to-peer network. Access to data shall be based upon logical identification of building equipment. No hardware or software limits shall be imposed on the number of devices with global access to the network data.

3. Network design shall include the following provisions:
 - a. Provide high-speed data transfer rates for alarm reporting, quick report generation from multiple controllers and upload/download efficiency between network devices. System performance shall insure that an alarm occurring at any DDC Controller is displayed at workstations and/or alarm printers within 5 seconds.
 - b. Support of any combination of DDC Controllers and operator workstations directly connected to the peer-to-peer network. A minimum of 64 devices shall be supported on a single network.
 - c. Message and alarm buffering to prevent information from being lost.
 - d. Error detection, correction and retransmission to guarantee data integrity.
 - e. Synchronisation of real-time clocks, to include automatic daylight savings time updating between all DDC Controllers shall be provided.

D. DDC Controller Local Area Network (LAN)

1. This level communication shall support a family of application specific controllers and shall communicate bi-directionally with the peer-to-peer network through DDC Controllers for transmission of global data.
2. A maximum of 32 application specific controllers may be configured on individual DDC Controller LANs to insure adequate global data and alarm response times. E. Telecommunication Capability:
 1. Auto-dial/auto-answer communications shall be provided to allow DDC Controllers to communicate with remote operator stations and/or remote terminals on an intermittent basis via telephone lines.
 2. Auto-dial DDC Controllers shall automatically place calls to workstations to report alarms or other significant events.
 - a. DDC Controllers shall be able to store a minimum of 10 phone numbers of at least 20 digits. Retry a single primary number at a fixed interval until successful.
 - b. The auto-dial program shall include provisions for handling busy signals, "no answers" and incomplete data transfers. Provide as a minimum 3 secondary numbers when communications cannot be established with the primary device.
3. Operators at dial-up workstations shall be able to perform all control functions, all report functions and all database generation and modification functions as described for workstations connected via the network. Routines shall be provided to automatically answer calls from remote DDC Controllers over telephone lines shall be completely transparent to an operator.

- a. An operator shall be able to access remote buildings by selection of any facility by its logical name. The workstation dial-up program shall store the phone numbers of each remote site, so the user shall not be required to remember or manually dial telephone numbers.
 - b. A PC workstation may serve as an operator device on a network, as well as a dial-up workstation for multiple auto-dial DDC Controllers on networks. Alarm and data file transfers handled via dial-up transactions shall not interfere with network activity, nor shall network activity keep the workstation from handling incoming calls.
4. Dial-up communications shall make use of TELKOM approved modem

DDC Controller

- A. Stand-alone Controllers shall be microprocessor-based with a minimum word size of 16 bits. They shall also be multi-tasking, multi-user, real-time digital control processors consisting of modular hardware with plug-in enclosed processors, communication controllers, power supplies and input/output point modules. Controller size shall be sufficient to fully meet the requirements of this specification.
- B. Each DDC Controller shall have sufficient memory, a minimum of 1.25 megabyte, to support its own operating system and databases, including:
 1. Control processes.
 2. Energy Management applications.
 3. Alarm management applications including custom alarm messages for each level alarm for each point in the system.
 4. Historical/trend data for points specified.
 5. Maintenance support applications.
 6. Custom processes.
 7. Operator I/O.
 8. Dial-up communications.
 9. Manual override monitoring.
- C. Each DDC Controller shall support:
 1. Monitoring of the following types of inputs, without the addition of equipment outside the DDC Controller cabinet: -
 - a. Analogue inputs
 - 1) 4-20 mA
 - 2) 0-10 Vdc
 - 3) 100 k ohm Thermistors
 - 4) 1000 ohm RTDs
 - b. Digital inputs
 - 1) Dry contact closure
 - 2) Pulse Accumulator
 - 3) Voltage Sensing
 2. Be capable of providing the following control outputs without the addition of equipment outside the DDC Controller cabinet:-
 - a. Digital outputs (contact closure).
 - b. Direct control of proportional electronic actuators and control devices.

Analogue outputs:-

- 1) 4-20 mA
- 2) 0-10 Vdc

- D. DDC Controllers shall provide at least two RS-232C serial data communication ports for operation of operator I/O devices such as industry standard printers, operator terminals, modems and portable laptop operator's terminals. DDC Controllers shall allow temporary use of portable devices without interrupting the normal operation of permanently connected modems, printers or terminals.
- E. Where required the operator shall have the ability to manually override automatic or centrally executed commands at the DDC Controller via local, point discrete, on-board hand/off/auto operator override switches for digital control type points and gradual switches for analogue control type points. These override switches shall be operable whether the panel processor is operational or not.
 1. Switches shall be mounted either within the DDC Controllers key-accessed enclosure, or externally mounted with each switch keyed to prevent unauthorised overrides.
 2. DDC Controllers shall monitor the status of all overrides and inform the operator that automatic control has been inhibited. DDC Controllers shall also collect override activity information for reports.
- F. DDC Controllers shall provide local LED status indication for each digital input and output for constant, up-to-date verification of all point conditions without the need for an operator I/O device. Graduated intensity LEDs or analogue indication of value shall also be provided for each analogue output. Status indication shall be visible without opening the panel door.
- G. Each DDC Controller shall continuously perform self-diagnostics, communication diagnosis and diagnosis of all panel components. The DDC Controller shall provide both local and remote annunciation of any detected component failures, low battery conditions or repeated failure to establish communication.
- H. Isolation shall be provided at all peer-to-peer network termination's as well as all field point termination's to suppress induced voltage transients consisted with IEEE Standards 587-1980.
- I. In the event of the loss of normal power, there shall be an orderly shutdown of all DDC Controllers to prevent the loss of database or operating system software. Nonvolatile memory shall be incorporated for all critical controller configuration data and battery backup shall be provided to support the real-time clock and all volatile memory for a minimum of 72 hours.
 1. Upon restoration of normal power, the DDC Controller shall automatically resume full operation without manual intervention.
 2. Should DDC Controller memory be lost for any reason, the user shall have the capability of reloading the DDC Controller via the local RS-232C port, via telephone line dial-in or from a network workstation PC.

DDC Controller resident software features

A. General:

1. All necessary software to form a complete operating system as described in this specification shall be provided.
2. The software programs specified in this Section shall be provided as an integral part of DDC Controllers and shall not be dependent upon any higher level computer for execution.

B. Control Software Description:

1. The DDC Controllers shall have the ability to perform the following pre-tested control algorithms:
 - a. Two-position control.
 - b. Proportional control.
 - c. Proportional plus integral control.
 - d. Proportional, integral, plus derivative control.
 - e. Control loop tuning.
2. Control software shall include a provision for limiting the number of times each piece of equipment may be cycled within any one-hour period.
3. The system shall provide protection against excessive demand situations during start-up periods by automatically introducing time delays between successive start commands to heavy electrical loads.
4. Upon the resumption of normal power, each DDC Controller shall analyse the status of all controlled equipment, compare it with normal occupancy scheduling and turn equipment on or off as necessary to resume normal operations.

C. DDC Controllers shall have the ability to perform any or all the following energy management routines:

1. Time-of day scheduling.
2. Calendar-based scheduling.
3. Holiday scheduling.
4. Temporary schedule overrides.
5. Start-Stop Time Optimisation.
6. Automatic Daylight Savings Time Switch over.
7. Night setback control.
8. Peak demand limiting.
9. Temperature-compensated duty cycling.
10. Fan speed control.
11. Heating/cooling interlock.
12. Supply air temperature reset.
13. Chilled water reset.
14. Condenser water reset.
15. Chiller sequencing.

All programs shall be executed automatically without the need for operator intervention and shall be flexible enough to allow user customisation. Programs shall be applied to building equipment as described in the Sequence of Operations.

D. DDC Controllers shall be able to execute custom, job-specific processes defined by the user, to automatically perform calculations and special control routines.

1. It shall be possible to use any of the following in a custom process:
 - a. Any system measured point data or status.
 - b. Any calculated data.
 - c. Any results from other processes.
 - d. User-defined constants.
 - e. Arithmetic functions (+, -, *, /, square root, exp, etc).
 - f. Boolean logic operators (and/or, exclusive or, etc).
 - g. On-delay/off-delay/one-shot timers.

2. Custom processes may be triggered based on any combination of the following:
 - a. Time interval.
 - b. Time-of-day.
 - c. Date.
 - d. Other processes.
 - e. Time programming.
 - f. Events (e.g. point alarms).

3. A single process shall be to incorporate measured or calculated data from any and all other DDC Controllers on the network. In addition, a single process shall be able to issue commands to points in any and all DDC Controllers on the network.

4. Processes shall be able to generate operator messages and advisories to operator I/O devices. A process shall be able to directly send a message to a specified device or cause the execution of a dial-up connection to a remote device such as a printer or pager.

5. The custom control programming feature shall be documented via English language descriptors.

- E. Alarm management shall be provided to monitor and direct alarm information to operator devices. Each DDC Controller shall perform distributed, independent alarm analysis and filtering to minimise operator interruptions due to non-critical alarms, minimise network traffic and prevent alarms from being lost. At no time shall the DDC Controllers ability to report alarms be affected by either operator or activity at a PC workstation, local I/O device or communications with other panels on the network.
 1. All alarm or point change reports shall include the point's English language description and the time and date of occurrence.

 2. The user shall be able to define the specific system reaction for each point. Alarms shall be prioritised to minimise nuisance reporting and to speed operator response to critical alarms. A minimum of six priority levels shall be provided for each point. Point priority levels shall be combined with user definable destination categories (PC, printer, DDC Controller, etc.) to provide full flexibility in defining the handling of system alarms. Each DDC Controller shall automatically inhibit the reporting of selected alarms during system shutdown and start-up. Users shall have the ability to manually inhibit alarm reporting for each point.

 3. Alarm reports and messages will be directed to a user-defined list of operator devices or PCS.

 4. In addition to the point's descriptor and the time and date, the user shall

be able to print, display or store a 200 character alarm message to more fully describe the alarm condition or direct operator response.

5. Each DDC Controller shall be capable of storing a library of at least 50 alarm messages. Each message may be assignable to any number of points in the Controller.
 6. In dial-up applications, operator-selected alarms shall initiate a call to a remote operator device.
- F. A variety of historical data collection utilities shall be provided to manually or automatically sample, store and display system data for points as specified in the I/O summary.
1. DDC Controllers shall store point history data for selected analogue and digital inputs and outputs:

Any point, physical or calculated may be designated for trending. Any point, regardless of physical location in the network, may be collected and stored in each DDC Controllers point group. Two methods of collection shall be allowed: either by a pre-defined time interval or upon a pre-defined change of value. Sample intervals of 1 minute to 7 days shall be provided. Each DDC Controller shall have a dedicated RAM-based buffer for trend data and shall be capable of storing a large number of data samples.
 2. Trend data shall be stored at the DDC Controllers and uploaded to the workstation when retrieval is desired. Uploads shall occur based upon either user-defined interval, manual command or when the trend buffers are full. All trend data shall be available for user in 3rd party personal computer applications.
 3. DDC Controllers shall also provide high resolution sampling capability for verification of control loop performance. Operator-initiated automatic and manual loop tuning algorithms shall be provided for operator-selected PID control loops. Provide capability to view or print trend and tuning reports.
 - a. In automatic mode, the controller shall perform a step response test with a minimum one-second resolution, evaluate the trend data, calculate the new PID gains and input these into the selected LOOP statement.
 - b. For troubleshooting in manual mode, the operator shall be able to select variables to override default values. Calculated PID gains shall then be reviewed before they are inserted into the selected LOOP statement.
 - c. Loop tuning shall be capable of being initiated either locally at the DDC controller, from a network workstation or remotely using dial-in modems. For all loop tuning functions, access shall be limited to authorised personnel through password protection.
- G. DDC Controllers shall automatically accumulate and store run-time hours for digital input and output points.
1. The totalisation routine shall have a sampling resolution of one minute or less.
 2. The user shall have the ability to define a warning limit for run-time

totalisation. Unique, user-specified messages shall be generated when the limit is reached.

- H. DDC Controllers shall automatically sample, calculate and store consumption totals on a daily, weekly or monthly basis for user-selected analogue and digital pulse input type points.
 - 1. Totalisation shall provide calculation and storage of accumulations of up to 99,999,9 units (eg kW, kWh, liters, etc).
 - 2. The totalisation routine shall have a sampling resolution of one minute or less.
 - 3. The user shall have the ability to define a warning limit. Unique, user-specified messages shall be generated when the limit is reached.

- I. DDC Controllers shall have the ability to count events such as the number of times a pump or fan system is cycled on and off. Event totalisation shall be performed on a daily, weekly or monthly basis.
 - 1. The event totalisation feature shall be able to store the records associated with a minimum of 9,999,9 events before reset.
 - 2. The user shall have the ability to define a warning limit. Unique, user-specified messages shall be generated when the limit is reached.

APPLICATION SPECIFIC CONTROLLERS (ASC)

- A. Each DDC Controller shall be able to extend its performance and capacity through the use of remote application specific controllers (ASCs)

- B. Each ASC shall operate as a stand-alone controller capable of performing its specified control responsibilities independently of other controllers in the network. Each ASC shall be a microprocessor-based, multi-tasking, real-time digital control processor.

PERSONAL COMPUTER OPERATOR INTERFACE/WORKSTATION HARDWARE

- A. A personal computer operator workstations shall be provided for command entry, information management, network alarm management and database management functions. All real-time control functions shall be resident in the DDC Controllers to facilitate greater fault tolerance and reliability.

Provide one workstation in the Building Manager's office on the ground floor of the building and shall consist of:

- 1. Mouse
- 2. Keyboard
- 3. CPU Case
- 4. 17" LCD touch screen display unit. Separate controls shall be provided for colour, contrasts and brightness. The screen shall be non-reflective.
- 5. CD plus disc drive for loading software.
- 6. Modem.

7. 2 kVA - 30minute UPS.

WORKSTATION OPERATOR INTERFACE

A. Basic Interface Description:

1. Operator workstation interface software shall minimise operator training through the use of English language prompting, English language point identification and industry standard PC application software. The software shall provide, as a minimum, the following functionality:-
 - a) Graphical viewing and control of environment.
 - b) Scheduling and override of building operations.
 - c) Collection and analysis of historical data.
 - d) Definition and construction of dynamic colour graphic displays.
 - e) Editing, programming, storage and downloading of controller databases.
 - a) Level 5 = All privileges
 - b) A minimum of 50 unique passwords, including user initials, shall be supported.
 - c) Operators will be able to perform only those commands available for their respective passwords. Menu selections displayed shall be limited to only those items defined for the access level of the password used on log-on.
 - d) The system shall automatically generate a report of log-on/log-off time and system activity for each user.
 - e) User-definable automatic log-off timers of from 5 to 60 minutes shall be provided to prevent operators from inadvertently leaving devices on-line.
2. Provide a graphical user interface which shall minimise the use of a typewriter style keyboard through the use of a mouse or similar pointing device and "point and click" approach to menu selection. Users shall be able to start and stop equipment or change set points form graphical displays through the use of a mouse.
 - a) Provide functionality such that all operations can also be performed using the keyboard as a backup interface device.
 - b) Provide additional capability that allows at least 10 special function keys to perform often-used operations.
3. The software shall provide a multi-tasking type environment that allows the user to run several applications simultaneously. The mouse shall be used to quickly select and switch between multiple applications. This shall be accomplished through the use of Microsoft Windows.

Provide functionality such that any of the following may be performed simultaneously, and in any combination, via user-sized windows:

 - a) Dynamic colour graphics and graphic control.
 - b) Alarm management coordinated with DDC Controllers.
 - c) Time-of-day scheduling.
 - d) Trend data definition and presentation.
 - e) Graphic definition.
 - f) Graphic construction.
4. Multiple-level password address protection shall be provided to allow the

user/manager to limit workstation control, display and data base manipulation capabilities as he deems appropriate for each user, based upon an assigned password.

- a) A minimum of five levels of access shall be supported:-
 - 1) Level 1 = view all applications, but perform no database modifications.
 - 2) Level 2 = Custodial privileges plus the ability to acknowledge alarms.
 - 3) Level 3 = All privileges except system configuration.
 - 4) Level 4 = All configuration privileges except passwords.
5. Software shall allow the operator to perform commands including, but not limited to, the following:
 - a) Start-up or shutdown selected equipment.
 - b) Adjust set points.
 - c) Add/modify/delete time programming.
 - d) Enable/disable process execution.
 - e) Lock/unlock alarm reporting for points.
 - f) Enable/disable totalisation for points.
 - g) Enable/disable trending for points.
 - h) Override PID loop set points.
 - i) Enter temporary override for points.
 - j) Define holiday schedules.
 - k) Change time/date.
 - l) Automatic daylight savings time adjustments.
 - m) Enter/modify analogue alarm limits.
 - n) Enter/modify analogue warning limits.
 - o) View limits.
 - p) Enable/disable demand limiting for each meter.
 - q) Enable/disable duty cycle for each load.
6. Reports shall be generated and directed to displays, printers or disk. As a minimum, the system shall allow the user to easily obtain the following types of reports:-
 - a) A general listing of all points in the network.
 - b) List of all points currently in alarm.
 - c) List of all points currently in override status.
 - d) List of all disabled points.
 - e) List of all points currently locked out.
 - f) DDC Controller trend overflow warning.
 - g) List all weekly schedules.
 - h) List of holiday programming.
 - i) List of limits and headbands.
7. Summaries shall be provided for specific points, for a logical point group, for a user selected group or groups or for the entire facility without restriction due to the hardware configuration of the building automation system. Under no conditions shall the operator need to specify the address of the hardware controller to obtain system information.

B. Scheduling:

1. Provide a graphical spreadsheet-type format for simplification of time-of-day scheduling and overrides of building operations. Provide the following spreadsheet graphic types as a minimum:-
 - a) Weekly schedules.
 - b) Zone schedules.

- c) Monthly calendars.
- 2. Weekly schedules shall be provided for each building zone or piece of equipment with a specific occupancy schedule. Each schedule shall include columns for each day of the week as well as holiday and special day columns for alternate scheduling on user-defined days. Equipment scheduling shall be accomplished by simply inserting occupancy and vacancy times into appropriate information blocks on the graphic. In addition, temporary overrides and associated times may be inserted into blocks for modified operating schedules. After overrides have been executed, the original schedule will automatically be restored.
- 3. Zone schedules shall be provided for each building zone as previously described. Each schedule shall include all commendable points residing within the zone. Each point may have a unique schedule of operation relative to the zone's occupancy schedule, allowing for sequential starting and control of equipment within the zone. Scheduling and rescheduling of points may be accomplished easily via the zone schedule graphic.
- 4. Monthly calendars for a 24-month period shall be provided which allow for simplified scheduling of holidays and special days in advance. Holidays and special days shall be user-selected with the pointing device and shall automatically reschedule equipment operation as previously defined on the weekly schedules.

C. Collection and Analysis of Historical Data.

- 1. Provide trending capabilities that allow the user to easily monitor and preserve records of system activity over an extended period of time. Any system point may be trended automatically at time-based intervals or changes of value, both of which shall be user-definable. Trend data may be stored on hard disk for future diagnostics and reporting.
- 2. Trend data report graphics shall be provided to allow the user to view all trended point data. Reports may be customised to include individual points or pre-defined groups of at least 6 points. Provide additional functionality to allow any trended data to be transferred easily to an off-the-shelf spreadsheet package such as Lotus 1-2-3. This shall allow the user to perform custom calculations such as energy usage, equipment efficiency and energy costs and shall allow for generation of these reports on high-quality plots, graphs and charts.
- 3. Provide additional functionality that allows the user to view trended data on trend graph displays. Displays shall be actual plots of both static and/or real-time dynamic point data. A minimum of 4 points may be viewed simultaneously on a single graph, with colour selection and line type for each point being user-definable. Displays shall include an 'X' axis indicating elapsed time and a 'Y' axis indicating a range scale in engineering units for each point. The 'Y' axis shall have the ability to be manually or automatically scaled at the user's option. Different ranges for each point may be used with minimum and maximum values listed at the bottom and top of the 'Y' axis. All 'Y' axis data shall be colour-coded to match the line colour for the corresponding point.
 - a) Static graphs shall represent actual point data that has been trended and stored on disk. Exact point values may be viewed on a data window by pointing or scrolling to the place of interest along the graph. Provide capability to print any graph on the system printer for use as a building management and diagnostics tool.

- b) Dynamic graphs shall represent real-time point data. Any point or group of points may be graphed, regardless of whether they have been redefined for trending. The graphs shall continuously update point values. At any time the user may redefine sampling times or range scales for any point. In addition, the user may pause the graph and take "snapshots" of screens to be stored on the workstation disk for future recall and analysis. As with static graphs, exact point values may be viewed and the graphs may be printed.

D Dynamic Colour Graphic Displays

1. Colour graphic floor plan displays and system schematics for each piece of mechanical equipment, including air handling units, chilled water systems and hot water boiler systems, shall be provided by the BMS contractor to optimise system performance analysis and speed-up alarm recognition.

To accomplish this, the user shall be able to build graphic displays that include point data from multiple DDC Controllers including Application Specific Controllers.

E System Configuration and Definition

1. All temperature and equipment control strategies and energy management routines shall be definable by the operator. System definition and modification procedures shall not interfere with normal system operation and control.
2. The operator interface shall allow users to access the various system schematics and floor plans via a graphical penetration scheme, menu selection or text-based commands.
3. Dynamic temperature, humidity, flow, pressure etc values and status indication shall be shown in their actual respective locations and shall automatically update to represent current conditions without operator intervention.
4. The windowing environment of the PC operator workstation shall allow the user to simultaneously view several graphics at a time to analyse total building operation or to allow the display of a graphic associated with an alarm to be viewed without interrupting work in progress.
5. Graphic generation software shall be provided to allow the user to add, modify or delete system graphic displays.
 - a) The BMS contractor shall provide libraries of pre-engineered screens and symbols depicting standard air handling unit components (eg fans, cooling coils, filters, dampers, etc) complete mechanical systems (eg constant volume-terminal reheat, VAV, etc) and electrical symbols.
 - b) The graphic development package shall use a mouse or similar pointing device in conjunction with a drawing program to allow the user to perform the following:-
 - 1) Define symbols.
 - 2) Position and size symbols.
 - 3) Define background screens.
 - 4) Define connecting lines and curves.
 - 5) Locate, orient and size descriptive text.
 - 6) Define and display colours for all elements.
 - 7) Establish correlation between symbols or text and associated system

points or other displays.

- c) Graphical displays can be created to represent any logical grouping of system points or calculated data based upon building function, mechanical system, building layout or any other logical grouping of points which aids the operator in the analysis of the facility.
2. The system shall be provided complete with all equipment and documentation necessary to allow an operator to independently perform the following functions:
 - a) Add/delete/modify stand-alone DDC Controller panels.
 - b) Add/delete/modify operator workstations.
 - c) Add/delete/modify application specific controllers.
 - d) Add/delete/modify points of any type and all associated point parameters and tuning constants.
 - e) Add/delete/modify alarm reporting definition for points.
 - f) Add/delete/modify control loops.
 - g) Add/delete/modify energy management applications.
 - h) Add/delete/modify time and calendar-based programming.
 - i) Add/delete/modify totalisation for points.
 - j) Add/delete/modify historical data trending for points.
 - k) Add/delete/modify custom control processes.
 - l) Add/delete/modify any and all graphic displays, symbols and cross-reference to point data.
 - m) Add/delete/modify dial-up telecommunication definition.
 - n) Add/delete/modify all operator passwords.
 - o) Add/delete/modify alarm messages.
 3. Definition of operator device characteristics, DDC Controllers individual points, applications and control sequences shall be performed using instructive prompting software.
 - a) Libraries of standard application modules such as temperature, humidity and static pressure control may be used as "building blocks" in defining or creating new control sequences. In addition, the user shall have the capability to easily create and archive new modules and control sequences as desired via a word processing type format. Provide a library of standard forms to facilitate definition of point characteristics. Forms shall be self-prompting and incorporate a fill-in-the-blank approach for definition of all parameter. The system shall immediately detect an improper entry and automatically display an error message explaining the nature of the mistake.
 - b) If programming must be done with the PC workstation off-line the BAS contractor shall provide at least 2 operator workstations.
 - c) Inputs and outputs for any process shall not be restricted to a single DDC Controller, but shall be able to include data from any and all other network panels to allow the development of network-wide control strategies. Processes shall also allow the operator to use the results of one process as the input to any number of other processes (cascading).
 - d) Provide the capability to backup and store all system databases on the workstation hard disk. In addition, all database changes shall be performed while the workstation is on-line without disrupting other system operations. Changes shall be automatically recorded and downloaded to the appropriate DDC Controller. Similarly, changes made at the DDC Controllers shall be automatically uploaded to the workstation, ensuring system continuity. The user shall also have the

option to selectively download changes as desired.

- e) Provide context-sensitive help menus to provide instructions appropriate with operations and applications currently being performed.

F. It must be possible to use a word processing and/or spreadsheet program such as WINDOWS WORD or EXCEL while the operating software is on line so that alarms and system events continue to be received.

Field Devices

- A. All devices and equipment shall be of the same manufacture.
- B. Temperature Sensors.
- C. Humidity Sensors.
- D. Pressure/Differential Pressure Sensors.
- E. Dampers Operators.
- F. Automatic Control valves.
- G. Overheat Safety / Fire Stats.
- H. Differential Pressure Switch.
- I. Electronic-to-Pneumatic Transducers.

INSTALLATION

All extra-low voltage BMS cables shall be run in screened twisted pair cables. They shall be drawn into conduit or trunking and protected as agreed with the engineer to suit the various environmental, social and mechanical locations. Cable specifications shall meet the manufacturers requirements, particularly respecting over-all resistance and capacitance limits. Where possible no joints will be allowed in cables, where these prove necessary the cables shall be jointed using an approved housing, securely fixed and having cable securing clamps. Any such connecting boxes shall be shown on the record drawings. No BMS data cable shall be installed in the same conduit as any power cable nor affixed within 25mm if surface/tray mounted. Where cables are run in trunking or with others clipped to tray of a similar type they shall be identified either by colour of labels every 2m.

Care shall be taken to ensure that the manufacturer's recommendations with respect to earthing data cables and DDC Controllers are obeyed.

Each BMS field device shall be identified (internally on space temperature and humidity sensors) with a common code used on points and wiring schedules, parts lists. Control strategy, MCP and installation diagrams/drawings.

Where a device is fitted with Auto/Man/Off switches, a common circuit shall monitor their auto condition, which shall cause an alarm when any switch is moved from the auto position.

All BMS cables shall be suitably with sleeves at the termination's. These shall be recorded on the installation diagrams and wiring schedules.

Sensors, actuators, switches and all field devices shall be mounted according to the manufacturer's instructions. All will be installed with clearance to allow for servicing and the conduit connected by methods to allow easy replacement.

The VAV units are all fitted with Ziehl Zetavent speed-controllers and the control system provided is to be fully compatible with the equipment.

The supply temperature for these units is reset by a signal received from the room temperature controllers. Up to 20 room thermostats per air handling unit may be installed.

The room variable air volume diffusers are to be controlled as shown on the schematic drawings. Setpoint adjustment and temperature indication shall be via the BMS.

The controller must incorporate a remote sensor complete with manual set point adjustment. The controller must have facilities to limit the effective set point adjustment at the sensor from zero to ± 5 deg C with respect to the set point as set via the Operator's Terminal.

The controller must be able to modulate up to 4 VAV diffuser actuators of 3 VA capacity each and switch via an adjustable time proportioning signal up to 43 kW heater via a 24 vac, 3 VA relay/contractor installed at each diffuser. Where more than 3 slave units are required per master then the necessary relays must be included to cater for this requirement.

Selected diffuser controllers will provide room temp feedback to the air conditioning unit controllers to off-set the respective supply temperatures.

The minimum requirements for the BMS monitoring and control the VAV diffuser controls are:-

- a) temperature indication
- b) set point adjustment
- c) damper position indication
- d) heater status
- e) override heater control (switch off)

Where DDC Controllers switch circuits having potentially different mains voltage supply feeds, extra low voltage relay circuit shall be employed. A notice shall be fixed inside the outstation detailing how all mains feeds into it can be isolated. Consideration shall be given to employing an extra low voltage control circuit for motor starter and contractor coils and shall be mandatory where MCP with separate cubicles for motor starters are employed.

In each riser cupboard and Plantroom through which network cables pass and not having an outstation a loop of cable will be made to allow future system expansion.

Network cable will be supplied with at least two spare pairs to allow for future system expansion.

COMMISSIONING

The BMS specialist shall be responsible for the full commissioning of his system and any other controls equipment supplied by him. Commissioning shall be in accordance with the "CIBSE Commissioning Code; Series C, Automatic Controls".

All safety interlocks, overrides and fail-safe conditions are to be operational prior to starting the plant.

Sensors shall be checked to ascertain accuracy within limits, pressure switches checked for switch points and hysteresis.

All the necessary test equipment and materials used in commissioning shall be supplied by the BMS specialist. All test equipment shall have valid test certificates.

Trend graphs will be provided to demonstrate the stable control of the plant. Simulated inputs will be employed to check stability over the design environmental range.

EQUIPMENT CONTROLLED/MONITORED BY THE BMS

The equipment shall be controlled and monitored as per the control schematics,

including:

(BMS - Indicates control, BMS(S) - Indicated status indication)

DDC Controller(s) located within the chiller plant electrical panel will provide the control for the a/c plant as shown on the control schematics.

In addition to the BMS being able to reflect the status of all plant controllers, including the position of all valves and actuators, input from all sensors and value of all set points, additional sensors shall be provided for the monitoring of building supply water temperature (1 off) and return chilled water temperature from the secondary systems.

DDC Controller(s) will control the fresh air systems as shown on the control schematic drawings.

Chilled water air handling units are located in plant room's through-out the building. Stand-alone controllers will provide the control as indicated on the control schematics.

2.10.3 **BMS POINTS LISTS**

BMS POINTS	ALL AHUs /OHUs	TOTALS
Type of Plant	CAV	
Analogue Inputs (AI)		
Supply Air Temp	9	
Return Air Temp	9	
Space Temp 1	9	
Space Temp 2		
Outside Air Temp	9	
End of Line Temp Sensors	9	
Pressure Sensors	9	
CO Sensor		
CO ₂ Sensor	9	
TOTAL AI's	63	63
Digital Input (DI)		
Fire Signal Status	9	
Run	9	
Fault	9	
Air Pressure Switch Status	9	
Filter Dirty Pressure Switch	18	
Remote on/off	9	
Remote Set point Adjuster	9	
TOTAL DI's	72	72
Analogue Output (AO)		
Hot / Chilled Water Valve		
Heater Current Valve		
Variable Speed Drives	9	
AHU Outside air Dampers	9	
TOTAL AO's	18	18
Digital Output (DO)		
Stop/Start	9	
Heaters Step 2		
Heaters Step 3		
Reheaters Enable		
TOTAL DO's	9	9

2.11 DESIGN CRITERIA

2.11.1 FUNCTIONAL PERFORMANCE

Outside Conditions		Summer 37°C DB 22.0°C WB Winter 2.1°C DB 1.8°C WB
<u>Inside Conditions</u>	Offices, Classrooms/Labs	Summer Temperature 24°C DB Relative Humidity \pm 50% Winter Temperature 21°C DB
<u>Control Tolerance</u>	Offices, Classrooms General Areas	Temperature \pm 1.5°C Relative Humidity not directly controlled but generally in the range of 40% to 60%

Internal Loads

Lighting – Offices, Class Room / Labs	-	15 w/m ²
Open Plan Offices	-	1 person per 4 m ²
Cellular Offices	-	1 person per 8 m ²
Teaching Area	-	1 person per 1.5 m ²
Reception	-	1 person per 5 m ²
Meeting Rooms	-	1 person per 2 m ²
Kitchen Sit	-	1 person per 2 m ²

Outside Air 7.5 l/s / person or 2ACH

Altitude 115m above sea level.

Noise Levels

The air conditioning and ventilation systems must be designed to maintain the background noise levels as specified below. The design target should be the first mentioned NR value. If the second NR value is exceeded then corrective measures must be implemented.

ITEM	AREA	NR LEVEL	DESIGN dBA	Max dBA
1.	Galleries	30-35	35	41

MEASURES TO REDUCE NOISE AND VIBRATION

- All equipment is to be placed on spring mounts with a minimum deflection of 10 mm.

2.12 SCHEDULES

TO BE COMPLETED BY ALL TENDERERS

2.12.1 AIR HANDLING UNITS

NB: All equipment to be guaranteed for a minimum of 2 years
 All equipment to be approved before ordering
 All equipment to be Intramech.

2.12.1.1 FIRST FLOOR FCUs

AHU NO					
Area Served					
Type of Unit					
Model Number					
Quantity					
Total Cooling	kW				
Sensible Cooling	kW				
Outside Air	m ³ /s				
Air Entering Coil Conditions	°C db /°C wb				
Air Leaving Coil Conditions	°C db /°C wb				
Chilled Water Entering / Leaving	°C				
Total Heating	kW				
Air Entering / Leaving	°C				
Heating Water Entering / Leaving	°C				
Electrical Power Supply	W				
Phase/Volt/Hz					

AHU NO					
Area Served					
Type of Unit					
Model Number					
Quantity					
Total Cooling	kW				
Sensible Cooling	kW				
Outside Air	m ³ /s				
Air Entering Coil Conditions	°C db /°C wb				
Air Leaving Coil Conditions	°C db /°C wb				
Chilled Water Entering / Leaving	°C				
Total Heating	kW				
Air Entering / Leaving	°C				
Heating Water Entering / Leaving	°C				
Electrical Power Supply	W				
Phase/Volt/Hz					

NOTES:

- Units to be fitted with condensate disposal pumps and AVM's.
- The HVAC Contractor is to allow for 1.5m of trapped galvanised condensate drain piping per unit.
- Drain piping in ceiling voids to run in galvanised cable trays.
- Exposed drain piping and control cables on walls to be enclosed in galvanised trunking and colour coded to match walls. Samples to be provided for approval.
- All units to be wrapped with 25mm Armaflex.
- All chilled water and hot water piping to be installed as per the specification. Supports to be HDG 100x50 channels.

2.13 MATERIALS AND LABOUR RATES

2.13.1 DUCTWORK

Fabrication by _____
 Installation by _____

2.13.2 DIFFUSERS

Make _____
 Model/Number _____
 Material _____

2.13.3 SUBLET WORK - where applicable

Tenderers to list any work or service which they intend to sublet and name the firm to whom they propose subletting the work.

<u>SERVICE</u>	<u>NAME OF FIRM</u>
_____	_____
_____	_____
_____	_____
_____	_____
_____	_____
_____	_____

2.13.4 RATES

The following schedule of rates will be used to calculate any variations to the contract. These rates are to include all P&G's, site establishment cost and mark-up.

ITEM	QUANTITY	RATE
<u>PVC DRAIN PIPING:</u>		
Ø25	per m	
Ø50	per m	
<u>GALVANISED CABLE TRAY:</u>		
Mesh Type (in ceiling void)	per m	
Closed Type (Plantroom Area)	per m	

ITEM	QUANTITY	RATE
<u>DIFFUSERS</u>		
Ø150	per unit	
Ø200	per unit	
Ø250	per unit	
Ø300	per unit	
Ø350	per unit	

ALL PRICES SHALL BE FOR WORK IN ACCORDANCE WITH THE SPECIFICATION AND SHALL BE NET AND EXCLUDE ANY DISCOUNTS AND VALUE ADDED TAX.

2.13.4.1 MATERIALS AND PLANT

Mark-up to cover overheads and profit – percentage%

2.13.5.1 LABOUR

	ARTISAN TEAM INCLUDING LABOURERS	ADDITIONAL LABOURERS	ENGINEER	SUPERVISOR	DRAUGHTSMEN
Normal Time/hr	R	R	R	R	R
Overtime Weekdays/hr	R	R	R	R	R
Sundays/hr	R	R	R	R	R
Transport	R	R	R	R	R
Capacity of Vehicle in Tons	Up to 1	Up to 2	Up to 3	3 to 5	Above 5
Per km	R	R	R	R	R



Scope of Works – JBCC



SCOPE OF WORKS
JBCC 2000 PRINCIPAL BUILDING AGREEMENT
(Edition 4.1 of March 2005)

PROJECT	WILLIAM HUMPHREYS ART GALLERY - UPGRADE OF HVAC SYSTEM
----------------	---

C3. Scope of Works

EXTENT OF THE WORKS

The works consist of the **UPGRADING OF HVAC SYSTEM** for WILLIAM HUMPHREYS ART GALLERY of the Northern Cape Province.

The scope of works includes, but is not limited to:

3.1. SCOPE OF WORK

The Contract, as detailed in these Specification Documents and the accompanying Drawings, comprises of the manufacture, supply, transport and delivery, hoisting, installation, testing, setting in operation, leaving in complete working order, and guarantee of the entire air conditioning plant and, except so far as the contract otherwise provides, the provision of all labour, materials, contractor's equipment and everything, whether of a temporary or permanent nature required in and for such manufacture, supply, offloading, hoisting, installation, testing, setting in operation, leaving in complete working order, guarantee so far as the necessity for providing the same is specified in or reasonably to be inferred from the contract.

3.1.1. Builder's Work shall be included in this contract and all such work, as later herein specified as being specifically included from this contract, shall be carried out the contractor as applicable and as provided herein.

3.1.2. Work by Contractor:

- All equipment plinths, bases and plant rooms. Metal plinth formers to be provided by HVAC Contractor.
- All plant enclosures
- All penetrations through walls, slabs, ceilings and steelwork
- Making good of all openings after installation of ductwork and equipment
- Waterproofing of all duct or piping entries to building through roofs, walls or the structure
- Cut outs in doors and installing door grilles supplied by Air Conditioning Contractor

NOTE: Ceiling panels must be removed by Air Conditioning Contractor.

- Water supply points terminating in valves
- Drain points. Galvanised steel drain piping to drain points must be provided by the HVAC Contractor.
- All as indicated on drawings.
- Mains incoming power supplies to the main air conditioning boards.
- Emergency power change over contactors, wiring to air conditioning plants and change over signal
- Wall boxes and conduit in brick walls or partitions for air conditioning controls
 - HVAC contractor to confirm all conduit and box sizes required.
- All as shown on drawings.
- Emergency power and fire signal to all smoke ventilation fans. HVAC contractor to provide all starters, wiring and manual test facility for each fan.



NOTE:

1. All final terminations in the air conditioning panels by the air conditioning contractor.
2. All air conditioning panels to be “top-entry” type.
3. Power distribution from air conditioning plant room distribution boards to AC units and fans is by the air conditioning Contractor.
4. All final connections between local isolator’s outdoor units and ventilation fans by the Air Conditioning Contractor.
5. All site wiring between outdoor and indoor units including controls by Air Conditioning Contractor.

POWER SUPPLY ON SITE

1. Voltage: 400/230V ±5
2. All AC Electrical Panels Fault Levels of 10 kA (Unless stated otherwise)

3.2. PROGRAMME

- 3.2.1. The tenderer shall execute these contract works strictly in accordance with the programme dates.
The entire air conditioning and ventilation installation must be commissioned, tested and taken over by the Engineer before practical completion:
- 3.2.2. The contractor shall be required within ONE WEEK after acceptance of his Tender, to submit to the Engineer for his approval a Programme showing the order in which the Works will be executed. Such programme shall show the times for the preparation of all drawings, ordering and delivery times promised by the suppliers for each major item of Plant, manufacturing and delivery times for all manufactured items, installation times and the programmed dates for testing and commissioning the Plant. The programme is to indicate the times required for all the electrical, builder’s and plumbing work.
The contractor shall submit TWO copies of his Programme to the Engineer for approval.. After submission to and approval by the Engineer of such Programme, the contractor shall adhere to the order of procedure and method stated therein unless he obtains the written permission of the Engineer to vary such order or method. The submission to and approval by the Engineer of such Programme shall not relieve the contractor of any of his duties or responsibilities under the contract.
- 3.2.3. The times required for the submission of Drawings are as follows: Shop Drawings within **ONE WEEK**

3.3. DESIGN CONDITIONS

The Engineer’s design for the air-conditioned areas has been based on the following Ambient Conditions, whilst maintaining the specified Internal Conditions.

Ambient Temperature	-Summer	: 37°C Dry Bulb 22°C Wet Bulb
	-Winter	: 2.1°C Dry Bulb
Internal Areas 1.5°C	- Summer	: 22°C Dry Bulb ±



ORDER OF THE WORKS

As per contractor's preliminary programme and as agreed by the Project Manager and not to exceed the contract period.

ACCESS

The site is located at WILLIAM HUMPHREYS ART GALLERY, 1 Cullinan Crescent Kimberley, Northern Cape.



Health and Safety Specification



STANDARD HEALTH AND SAFETY SPECIFICATION

Standard Bills

These specifications shall be used in conjunction with all other applicable Health and Safety specifications, Legislation as in Occupational Health and Safety Act no. 85 of 1993 as amended by Act no.181 of 1993, the Construction Regulations as promulgated in 2014 and incorporated into the OHS Act by Government Notice No. R1010 published in Government Gazette 25207, General Safety Regulations as promulgated on 18 July 2006 and incorporated into the OHS Act by Government Notice No. 1010 published in Government Gazette 25207 and all other relevant regulations incorporated into the OHS Act as well as ISO 9 000, all Environmental legislation such as:

- Environment Conservation Act No. 73 of 1989
- National Water Act No. 36 of 1998
- Hazardous Substances Act No. 15 of 1973
- Atmospheric Pollution Prevention Act No.45 of 1965
- Physical Planning Act 88 of 1967

GENERAL

- Client

The Client, Department of Roads and Public Works, shall execute his duties as per Regulation 4 of the Construction Regulations of 2003 that states *inter alia*, the following:

1. A client shall be responsible for the following in order to ensure compliance with the provisions of the Act-
 - (a) Prepare health and safety specifications for the construction work, and provide any Contractor who is making a bid or appointed to perform work for the client with the same;
 - (b) Appoint each Contractor in writing for the project or part thereof on a construction site;
 - (c) Take reasonable steps to ensure that each Contractor's health and safety plan is implemented and maintained on the construction site. Provided that the steps taken, shall include periodic audits at intervals, mutually agreed upon between the client and the Contractor, but at least once every month;
 - (d) Stop any Contractor from executing construction work, which is not in accordance with, the Contractor's health and safety plan;
 - (e) Ensure that where changes are brought about to the design or construction, sufficient health and safety information and appropriate resources are made available to the principal contractor to execute the work safely;
 - (f) Ensure that every Contractor is registered and in good standing with the Compensation fund or with a licensed compensation insurer prior to commencing on site.
 - (g) Ensure that potential principal contractors submitting tenders, have made provision for the cost of health and safety measures during construction process.

Therefore, the following specifications from the Client to the Contractor:

- Each and every Contractor shall make the following appointments and provide the necessary training accordingly:



- (a) Construction Works Supervisor
- (b) Health and Safety Representatives
- (c) Health and Safety Committee
- (d) Machinery Supervisor
- (e) Excavation Inspector
- (f) And all the necessary appointments as per the OHS Act and the relevant Regulations

All appointments should be completed before work commencement, signed, dated and completed in full, be fully explained to the nominated individual and should be at all times displayed on Site Notice Board that will have to be at least 600mm by 800mm.

- The Site Notice Board should also *inter alia*, have the following information on it:
 - a. Site regulations concerning safe working procedures
 - b. Information on the nearest first-aid station
 - c. Ambulance
 - d. Doctor
 - e. CSO's number and
 - f. Other relevant persons
- Each and every Contractor shall give notification of Construction work to the Office of the Department of Labour **PRIOR** to commencement of work.
- Each Contractor shall provide the Client with a Pre Site establishment checklist
- Each Contractor shall to monthly safety audits on the project and provide the Client with a copy thereof
- Each Contractor shall provide to the Client a Health and Safety Representative inspection checklist and ensure that Health and Safety representatives do inspections at least on a monthly basis
- Each Contractor shall provide and demonstrate to the Client a Health and Safety management policy
- As per the General Safety Regulations Regulation 4 as contemplated in the Basic Conditions of Employment Act, No. 3 of 1983, have the relevant amount of trained First-Aiders on site.
- In terms of Regulation 3 of the General Safety Regulations, provide a first-aid box or boxes on the premises of work
- In terms of Section 23 of the OHS Act, provide all workers at all times, with the necessary PPE.
- In terms of the Facilities Regulations provide the necessary facilities such as proper ablution, during space, lockers and any other item as per the Facilities Regulations that is necessary to carry out the work safely and without risk to the health of the workers.
- Keep an incident record book on site at all times.

SAFE WORKING LOADS

The Contractor shall ensure that where applicable:

- safe working loads of hoists, load bearing beams and cranes are prominently displayed at all times.
- The safe working loads are not exceeded under any circumstances.
- All lifting gear is marked with a unique identity number and recorded in a register



ELECTRICAL EQUIPMENT AND PROCEDURES USED BY THE CONTRACTOR

All electrical equipment shall be regularly inspected by a qualified electrician, who shall be appointed by the Contractor. And the inspections shall be logged. The frequency of inspections shall be determined by the Client. A record of the inspections shall be kept and shall be made available to the Client on request

The Contractor shall ensure that all his electrical equipment conforms to operational and safety requirements.

All earth leakage units shall be tested at intervals of not more than one month and signed for by a qualified electrician.

COMMISSIONING SAFETY PRECUATIONS

The Contractor shall ensure that wherever repairs, adjustments of any other work are undertaken on any plant or machinery, the power supply is switched off, disconnected or the plant/machinery disengaged until the work or repairs have been completed.

A Certificate of Completion by a qualified master electrician will be issued after electrical work is completed.

TOXIC MATERIALS

The Contractor shall exercise all necessary care in the handling of toxic compounds and shall be able to identify the major chemical components in the event of medical treatment being required.

A designated route as well as a dumping site will be identified for the transportation and disposal of waste material by the service provider.

INDEMNITY OF THE CLIENT AND HIS AGENTS

Annexure A to this Specification contains a “Mandatory Form of Authority and Agreement in terms of Section 37(2) of the Occupational Health and Safety Act No 85/93, as amended, which agreement shall be entered into and duly signed by both the Client and the Contractor prior to commencement of work. A copy of the signed agreement shall be included in the Contractor’s Health and Safety Plan.

Any acceptance, approval, check, certificate, consent, examination, inspection, instruction, notice observation, proposal, request, test or similar act by either the Client or any of his Agents, including lack of disapproval, shall not relieve the Contractor from any responsibility he has under the Act and the relevant regulations (Construction Regulation), including responsibility for errors, omissions, discrepancies and non-compliance.



SPECIFIC REQUIRMENTS

Design

No significant hazards can be identified which have not been considered in the detailed design. However, hazard must be anticipated that are due to and arising from shoddy and careless workmanship and unconventional construction methods used by semi-qualified and unqualified craftsmen during skills transfer.

Work sequences are a logical progression of the construction of a building under consideration of the tender documentation, National Building Regulations, Regulations, the Standard Occupational Health and Safety Specifications, other specifications and manufacturers' instructions.

Security

The Contractor's material site must be properly secured.

Existing environment

The surrounding roads and properties will be pointed out to the Contractor at site handover.

If the flow of traffic is in no way going to be hampered by the contractor's work, the necessary traffic authorities must be immediately informed.

Existing services

All known services will be pointed out at site handover.

Contractors must recognize that all services on the site must be expected to be "live" and potentially critical to the safe functioning of the works. Precautions for any work on or near them should be identified, planned, approved and taken accordingly.

In the event that previously unidentified services are discovered, Contractors shall immediately refer detail of location, suspected condition and status to the Client and await instruction. On no account must any services be interfered with without specific instruction and authority.

Ground conditions

As per the geotechnical assessment.

Related restrictions affecting health and safety

Being in a residential area, normal daytime working hours are to be adhered to in order to minimize disturbance to surrounding residences.

No unauthorized blasting in a residential area will be done without authorization from the client.



Control of pollution

All rubble, refuse, etc. is to be disposed of in accordance with the municipal by-laws.

Needed to mention, the above mentioned health and safety specifications should be used in accordance with the standard specifications as can be found in the existing tender document of the Client.

The Client can and will, if necessary and in the interest of health and safety, amends the above mentioned specifications.

An identified and agreed dumping site will be used in case of hazardous material. A disposal certificate will be issued by the contractor after disposal.

- **Principal Contractor and Contractor**

In terms of Regulation 5 of the Construction Regulations, after receiving the health and safety specifications from the Client, the Principal Contractor shall provide and demonstrate to the Client a Health and Safety Plan. This Health and Safety Plan shall indicate that the (Contractor) shall perform, but is not limited to, the following duties:

GENERAL REQUIREMENTS

- Administration
- Appointments
- Safety committees
- Registers, Checklists and permits
- Incident management
- Emergency planning
- Contractors
- Risk assessment
- Audits
- Hazardous substance control
- Training
- Additional requirements
- Planning



Annexure:

The following annexures should be attached to the Health and Safety Plan and the format should be agreed upon between the Client and the Contractor:

- Pro forma for Construction Works Supervisor appointment
- Pro forma for Health and Safety Representative Appointment and his IOSH membership
- Pro forma for Machinery Supervisor appointment
- Pro forma for Excavation Inspector appointment
- Pro forma for Notification of Construction Work
- Pro forma – Pre Site Inspection Checklist
- Monthly Safety Audit Checklist
- Health and Safety Representative Inspection checklist
- Health and Safety Management Policy

CONCLUSION

The objectives of this document is to outline all necessary procedures required to implement and maintain a comprehensive Occupational Health and Safety System for Construction Projects in line with specifications prescribed by the Department of Roads and Public Works.

It is general business imperative of the Department of Roads and Public Works to understand and embrace safe working procedures. Violations of simple safety procedures can lead to injury and even loss of life. Every accident, no matter how minor, can be translated into costs against the Project. These costs are both direct (damage to property, medical expenses, etc.) and indirect (investigation proceedings, disruption of work, delay in program, plant replacements, etc).

In order for an easier understanding of legislative requirements in particular with regard to the Construction Regulations this proposed planning document has been compiled in a very simplistic manner. It will therefore not focus on each and every scenario that may arise and does not intend to convey all requirements of statutes other than the following:

1. Occupational Health and Safety Act No. 85/93 as amended by Act No. 181/93
2. Incorporated Regulations of the Act – Construction Regulations of 2003
3. Relevant SABS codes of the Practice as per Section 40 of the OHS Act.
4. Compensation for Occupational Injury and Diseases Act no. 130 of 1993 as amended.



STANDARD ABBREVIATIONS
OCCUPATIONAL HEALTH AND SAFETY

ITEM	TERM	ABBREVIATION
1	Health and Safety	H&S
2	Occupational Health and Safety	OHS
3	Safety Health and environment Representative	SHE REP
4	Hazard Identification and Risk Assessment	HIRA
5	Personal Protective Equipment	PPE
6	General Administrative Regulations	GAR
7	Facilities Regulations	FR
8	General Safety Regulations	GSR
9	Environmental Regulations	ER
10	Electrical Installation Regulations	EIR
11	Asbestos Regulations	AR
12	Driven Machinery Regulations	DMR
13	General Machinery Regulations	GMR
14	Electrical Machinery Regulations	EMR
15	Diving Regulations	DR
16	Lead Regulations	LR
17	Vessels under Pressure Regulations	VPR
18	Regulations for Hazardous Chemicals Substances	HAZCHEM Reg.
19	Major Hazard Installation Regulations	MHIR
20	Construction Regulations	CR
21	Mines Health and Safety Act	MHS ACT
22	Compensation for Occupational Injuries and Diseases Act	COIDA
23	South African Bureau of Standards	SABS
24	Construction Safety Officer	CSO
25	Medical Safety Data Sheet	MSDS
26	Tunnelling Regulations	TR
27	Traffic Calming Devices	TCD
28	Environmental Impact Assessment	EIA
29	Hazardous Chemical Substances	HCS
30	Dangerous Goods	DG
31	Dry Chemical Powders	DCP



HEALTH AND SAFETY SPECIFICATION
BREAKDOWN OF MINIMUM EXPECTED COST ITEMS
ITEM 1.6 OF PRELIMINARIES

Breakdown of Minimum Expected Cost relating to Health and Safety shall be priced accordingly as set out in **Preliminaries and General, Bill of Quantities, item 1.6, Health and Safety**. Contractors are to price all items indicated, summarised under Collections and total price for **Health and Safety** and carried over to Final Summary.



PART C4: SITE INFORMATION



Site Information – JBCC

SITE INFORMATION
JBCC 2000 PRINCIPAL BUILDING AGREEMENT
(Edition 4.1 of March 2005)

Project title:	WILLIAM HUMPHREYS ART GALLERY - UPGRADE OF HVAC SYSTEM
-----------------------	--

C4 Site Information

1. LOCATION AND ACCESS

The site is located at the **1 Cullinan Crescent, CIVIC CENTRE Kimberley, Sol Plaatje Municipality, Northern Cape.**

Please contact the project leader for confirmation of the site. The project leader for this project is:

Mr. T. Semoa, contact the WHAG at 053 831 1724/5 for more information.



2. NATURE OF THE GROUND (DOLOMITE)

N/A.

3. DOLOMITE LOCALITY MAP

N/A

4. General Geotechnical Report

N/A



DRAWINGS

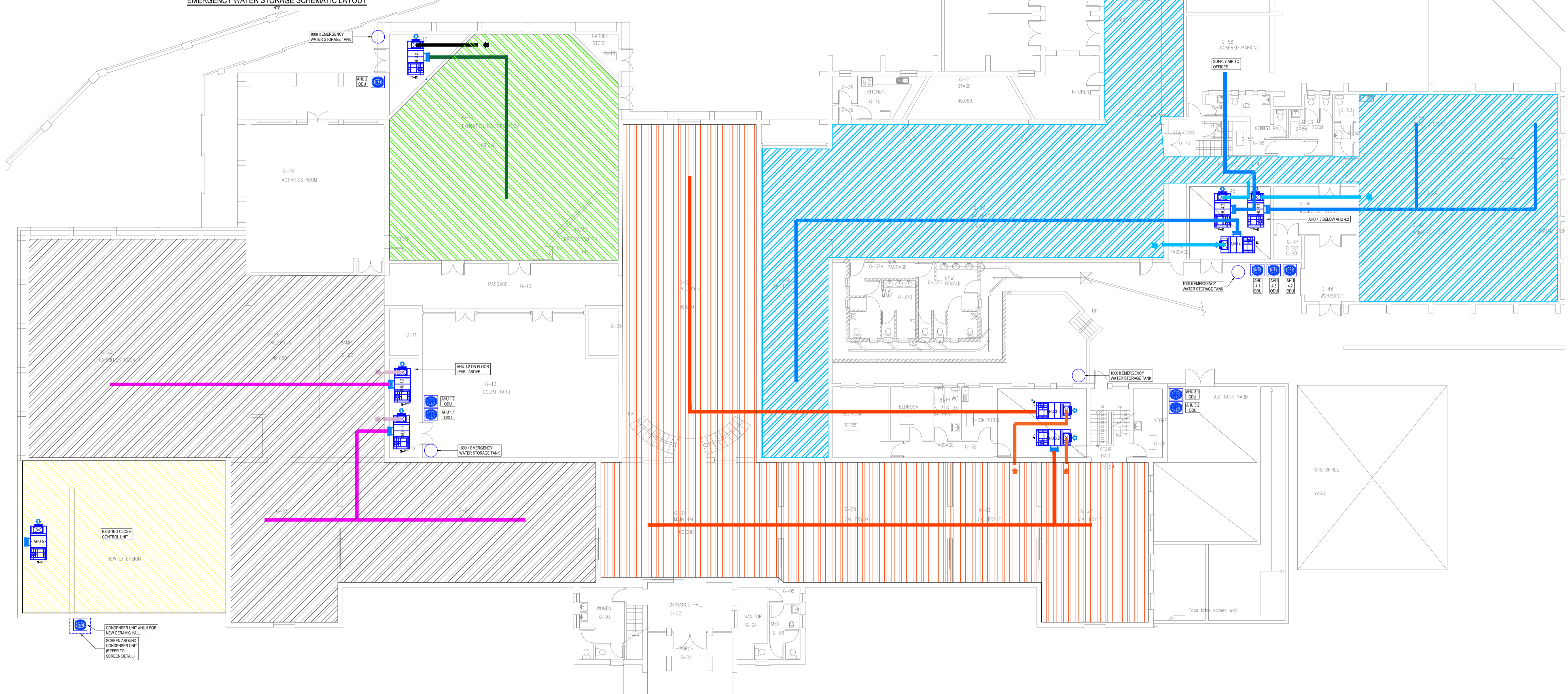
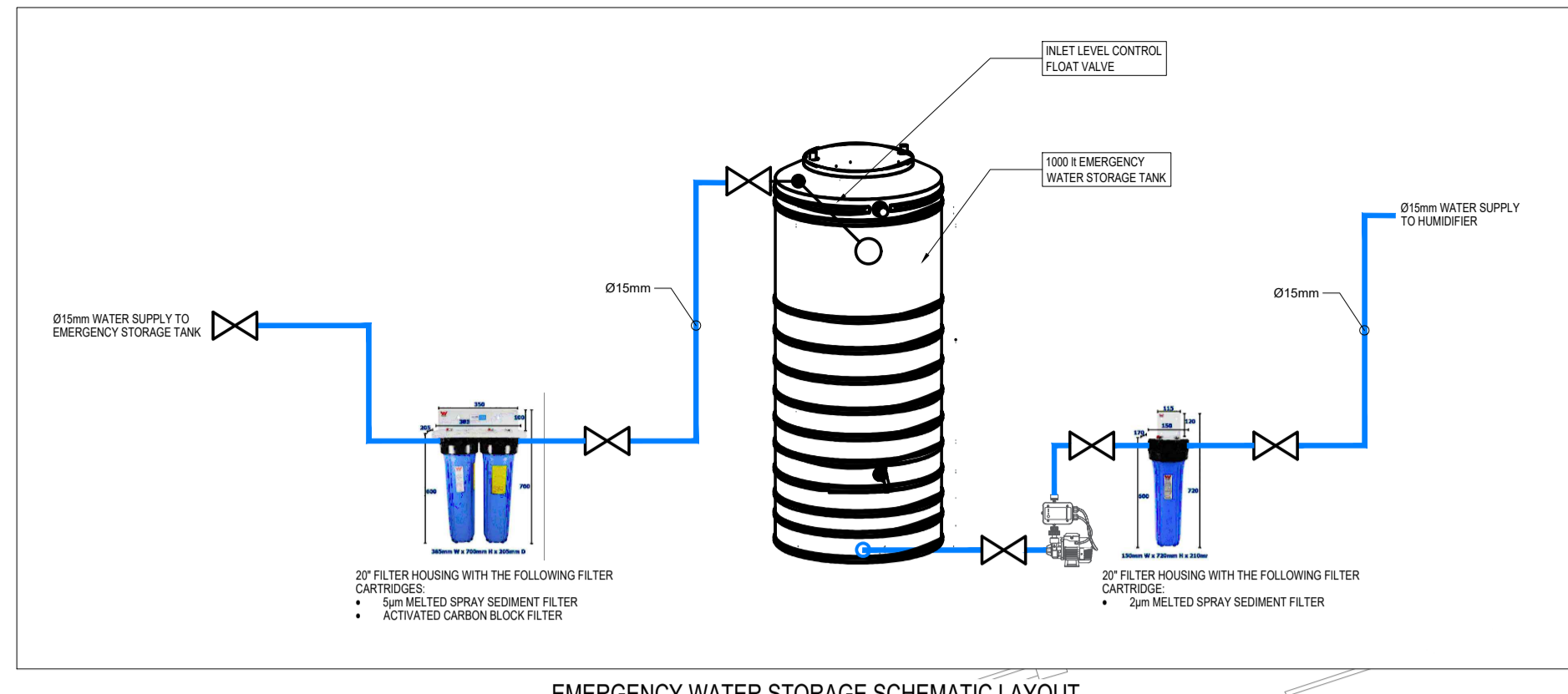

- GENERAL NOTES:**
1. SHEET METAL DUCTING MUST BE GALVANISED MILD STEEL, WITH MEZZ FLANGES. ALL HVAC EQUIPMENT TO BE ACCURATELY SUPPORTED AT REGULAR INTERVALS WITH SUITABLE THREADED ROD AND NUTS (BAG AS PER 880-110)
 2. ALL DUCTWORK JOINTS MUST BE PROPERLY SEALED AND AIRTIGHT.
 3. ALL DOORS TO TOILETS WITH MECHANICAL VENTILATION TO BE UNDERCUT MINIMUM 20mm.
 4. THE HVAC CONTRACTOR TO WIRE BETWEEN THE HVAC EQUIPMENT AND HVAC DB OR ISOLATOR.
 5. ALL ARTIFICIAL VENTILATION SYSTEMS MUST NOT EMIT A NOISE LEVEL OF WHICH CAUSE THE AMBIENT NOISE LEVEL TO EXCEED 50dB(A) MEASURED AT THE BOUNDARY OF PROPERTY.
 6. ALL EQUIPMENT MUST BE MOUNTED ON ANTI-VIBRATION MOUNTINGS.
 7. AC UNITS FINAL POSITIONS TO BE INSTALLED TO ARCHITECT'S DIMENSIONS AS PART OF CO-ORDINATION.
 8. ACCESS HATCHES POSITIONS TO ARCHITECT'S CO-ORDINATED CEILING LAYOUT.
 9. FINAL DIFFUSER POSITIONS AS PER ARCHITECT'S CO-ORDINATED CEILING LAYOUT - COLOUR TO ARCHITECT'S SPECIFICATION.
 10. FINAL WEATHER LOUVER POSITIONS AS PER ARCHITECT'S ELEVATION DRAWINGS COLOUR TO ARCHITECT'S SPECIFICATION.
 11. ALL FIRE DAMPERS MUST BE 200mm LONG ELECTROVENT OR EQUAL AND APPROVED.
 12. ALL WASHABLE FILTERS MUST BE INSTALLED WITH FRATS IN THE VERTICAL.
 13. SOUND ATTENUATORS MUST HAVE 100mm OR 150mm AIR GAPS WITH LENGTHS AS INDICATED.
- NOTES TO BUILDER:**
1. BUILDER TO PROVIDE PENETRATIONS THROUGH CONCRETE SLAB & BRICK WALLS FOR HVAC EQUIPMENT AND MAKE GOOD AFTER INSTALLATION OF HVAC EQUIPMENT.
 2. FIRE STOPPING & SEALING OF ALL DUCT & PIPE ENTRIES TO ARCHITECT'S DETAIL.
 3. ALL WEATHER LOUVER PENETRATIONS THROUGH WALLS MUST BE COMPLETE WITH 25mm TIMBER FRAME FOR THE SCREW FIXING OF WEATHER LOUVER & GRILLES WEATHER LOUVER TO BE FITTED WITH VERMIN PROOF MESH.
 4. DOOR GRILLES - 1000x300 (UNLESS NOTED OTHERWISE) SUPPLIED BY AIR-CONDITIONING CONTRACTOR AND CUT AND FITTED BY BUILDER.
 5. ALL EXTERNAL PENETRATIONS TO BE COMPLETE WITH BURGLAR BARS.
- NOTES TO ELECTRICAL CONTRACTOR:**
1. PROVIDE POWER SUPPLY TO ALL HVAC DB'S & ISOLATORS AS INDICATED ON DRAWING COMPLETE WITH CONDUITS, DRAW-WIRES & JUNCTION BOXES.
 2. ELECTRICAL POWER SUPPLIES & ISOLATORS TO BE PROVIDED WITH A METER OF HVAC EQUIPMENT.
 3. ISOLATORS TO FAN COIL UNITS AND FANS TO BE IN CEILING SPACE WITHIN A METER OF HVAC EQUIPMENT.
- TO PLUMBING SUB-CONTRACTOR:**
1. PLUMBER TO PROVIDE TRAPS IN CEILING CONNECTED TO SEWER SYSTEM FOR CONDENSATE DRAINS - REFER TO DETAIL.
 2. CONDENSATE DRAIN FROM AC UNITS TO A TRAP IN CEILING BY AC CONTRACTOR.
 3. CONDENSATE DRAIN PIPES TO FOLLOW THE SHORTEST POSSIBLE ROUTE, AS DETERMINED ON SITE, ACCEPTABLE FALL 1:80 MIN AND SIZES TO BE AS SHOWN ON PLAN LAYOUT.

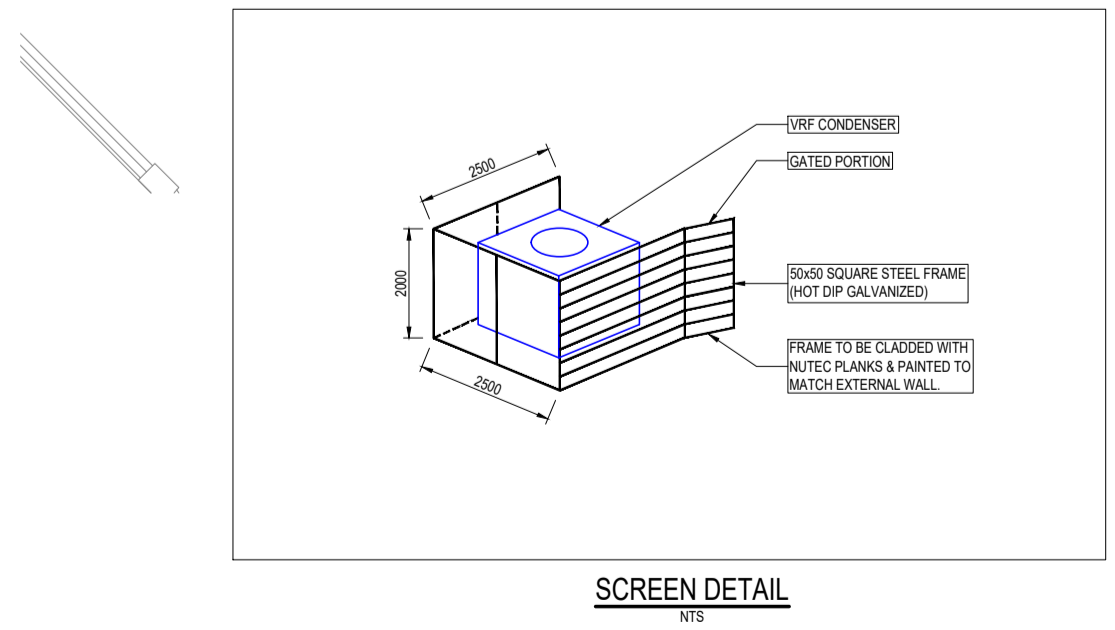

AIR HANDLING UNIT SCHEDULE

UNIT No.	TYPE	AREA SERVED	TOTAL COOLING CAPACITY (kW)	SUPPLY AIR (L/s)	OUTSIDE AIR (L/s)	DA DB (WB) (°C db & °C wb)	AIR LEAVING (°C db & °C wb)	ELECTRICAL SUPPLY (V / Ph / Hz)	POWER SUPPLY (A)	HUMIDIFIER (kg / hr)
AHU 1.1	HYBRID DX	GALLERY'S & C	16.5	1180	295	35 / 22	11.4 / 11.3	400 / 3 / 50	45	10.2
AHU 1.2	HYBRID DX	GALLERY & RAMP	21.1	1700	425	35 / 22	11.60 / 11.50	400 / 3 / 50	45	14.8
AHU 2	HYBRID DX	LECTURE ROOM	17.14	1410	350	35 / 22	11.75 / 11.65	400 / 3 / 50	45	12.2
AHU 3.1	HYBRID DX	GALLERY G	15.5	1060	265	35 / 22	11.4 / 11.3	400 / 3 / 50	45	9.3
AHU 3.2	HYBRID DX	GALLERY D, E & F & MAIN HALL	20.8	1600	395	35 / 22	11.45 / 11.35	400 / 3 / 50	45	13.8
AHU 4.1	HYBRID DX	GALLERY H & I	27.2	2075	530	35 / 22	11.41 / 11.31	400 / 3 / 50	45	18
AHU 4.2	HYBRID DX	OFFICES	12.03	880	175	35 / 22	16.1 / 15.6	400 / 3 / 50	45	5.8
AHU 4.3	HYBRID DX	STORAGE	15.32	1130	285	35 / 22	16.1 / 15.6	400 / 3 / 50	45	9.7
AHU 5	HYBRID DX	CERAMIC HALL	12.31	730	185	35 / 22	16.1 / 15.6	400 / 3 / 50	45	6.3

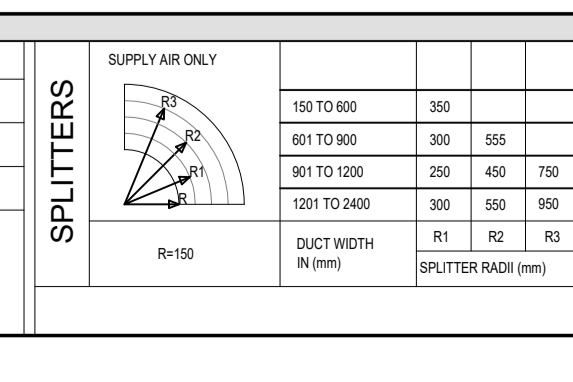
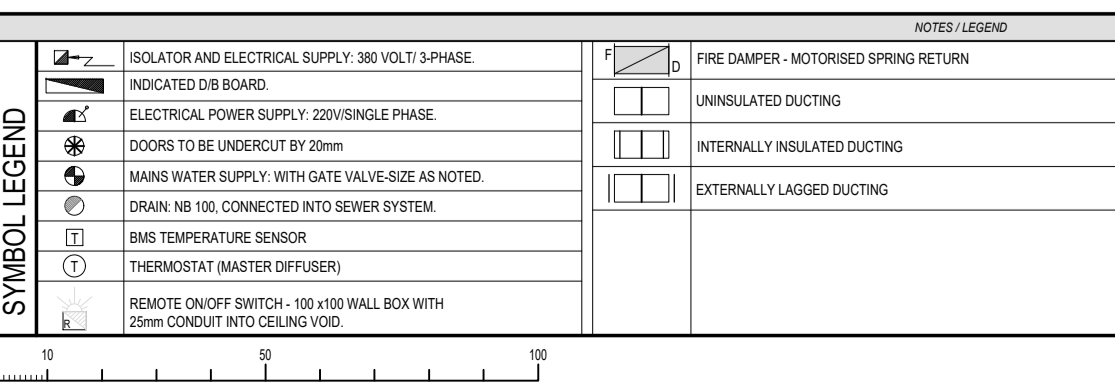

PROJECT STATUS

APPROVED BY COUNCIL/CLIENT

CITY ENGINEER / CLIENT REG. NO. DATE

AMENDMENT CODE

A. BY CLIENT
 B. BY ARCHITECT
 C. BY MECHANICAL OR ELECTRICAL
 D. BY BA
 E. BY OTHER ()

REVISION DESCRIPTION

DATE	INITIAL	NO.	CODE	REVISION DESCRIPTION
09/10/2023	S.B.	AD		DRAWING ISSUED FOR INFORMATION
09/10/2023	S.B.	BD		UPDATED FOR INFORMATION: • ADDED EMERGENCY WATER STORAGE SCHEMATIC INCLUDING FILTRATION • REPOSITIONED CONDENSER UNIT LOCATIONS FOR AHU 1.1 AND AHU 3.2 • INDICATED NEW CERAMIC HALL CONDENSER AND SCREEN WALL PROPOSED LOCATION
15/03/2024	S.B.	CD		UPDATED FOR INFORMATION: • ADDED EQUIPMENT SCHEDULE

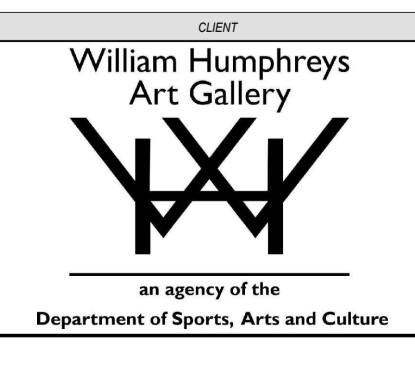

APPROVED BY

ROLE	NAME	DATE	DATE
Project Manager	J. du Plessis	09/10/2023	15/03/2024
Engineer/Technologist	S. Barnes	09/10/2023	15/03/2024
Designer	A. Malgas	09/10/2023	15/03/2024
Checker	A. Malgas	09/10/2023	15/03/2024
Approver	A. Malgas	09/10/2023	15/03/2024
Cap Type	A. Malgas	09/10/2023	15/03/2024

WILLIAM HUMPHREYS ART GALLERY

GROUND FLOOR HVAC LAYOUT

SCALE: 1:100 @ A1

DESIGNED BY: J. du PLESSIS

PROJECT NUMBER: 35129.00-741-01

REVISION NO. C

DATE SAVED: 15 March 2024

35129.00-741-01 REV C.DWG

- GENERAL NOTES:**
1. SHEET METAL DUCTING MUST BE GALVANNEED WLD STEEL, WITH MEZZ-FLANGES. ALL HVAC EQUIPMENT TO BE ACCURATELY SUPPORTED AT REGULAR INTERVALS WITH SUITABLE THREADED ROD AND NUTS (SAS AS PER SAS-110).
 2. ALL DUCTWORK JOINTS MUST BE PROPERLY SEALED AND AIRTIGHT.
 3. ALL DOORS TO TOILETS WITH MECHANICAL VENTILATION TO BE UNDERCUT MINIMUM 20mm.
 4. THE HVAC CONTRACTOR TO WIRE BETWEEN THE HVAC EQUIPMENT AND HVAC DB OR ISOLATOR.
 5. ALL ARTIFICIAL VENTILATION SYSTEMS MUST NOT EMIT A NOISE LEVEL OF WHICH CAUSE THE AMBIENT NOISE LEVEL TO EXCEED 55dB(A) MEASURED AT THE BOUNDARY OF PROPERTY.
 6. ALL EQUIPMENT MUST BE MOUNTED ON ANTI-VIBRATION MOUNTINGS.
 7. AC UNITS FINAL POSITIONS TO BE INSTALLED TO ARCHITECT'S DIMENSIONS AS PART OF CO-ORDINATION.
 8. ACCESS HATCHES POSITIONS TO ARCHITECT'S CO-ORDINATED CEILING LAYOUT.
 9. FINAL DIFFUSER POSITIONS AS PER ARCHITECT'S CO-ORDINATED CEILING LAYOUT - COLOUR TO ARCHITECT'S SPECIFICATION.
 10. FINAL WEATHER LOUVER POSITIONS AS PER ARCHITECT'S ELEVATION DRAWINGS COLOUR TO ARCHITECT'S SPECIFICATION.
 11. ALL FIRE DAMPERS MUST BE 200mm LONG ELECTROVENT OR EQUAL AND APPROVED.
 12. ALL WASHABLE FILTERS MUST BE INSTALLED WITH FRAMES IN THE VERTICAL.
 13. SOUND ATTENUATORS MUST HAVE 100mm OR 150mm AIR GAPS WITH LENGTHS AS INDICATED.
- NOTES TO BUILDER:**
1. BUILDER TO PROVIDE PENETRATIONS THROUGH CONCRETE SLAB & BRICK WALLS FOR HVAC EQUIPMENT AND MAKE GOOD AFTER INSTALLATION OF HVAC EQUIPMENT.
 2. FIRE STOPPING & SEALING OF ALL DUCT & PIPE ENTRIES TO ARCHITECT'S DETAIL.
 3. ALL WEATHER LOUVER PENETRATIONS THROUGH WALLS MUST BE COMPLETE WITH 25mm TIMBER FRAME FOR THE SCREW FIXING OF WEATHER LOUVERS & GRILLES SUPPLIED BY AIR CONDITIONING CONTRACTOR AND CUT AND FITTED BY BUILDER.
 4. DOOR GRILLES - 150x300 (UNLESS NOTED OTHERWISE) SUPPLIED BY AIR CONDITIONING CONTRACTOR AND CUT AND FITTED BY BUILDER.
 5. ALL EXTERNAL PENETRATIONS TO BE COMPLETE WITH BURGLAR BARS.
- NOTES TO ELECTRICAL CONTRACTOR:**
1. PROVIDE POWER SUPPLY TO ALL HVAC DB'S & ISOLATORS AS INDICATED ON DRAWING COMPLETE WITH CONDUITS, DRAW WIRES & JUNCTION BOXES.
 2. ELECTRICAL POWER SUPPLIES & ISOLATORS TO BE PROVIDED WITH A METER OF HVAC EQUIPMENT.
 3. ISOLATORS TO FAN COOL UNITS AND FANS TO BE IN CEILING SPACE WITHIN A METER OF HVAC EQUIPMENT.
- TO PLUMBING SUB-CONTRACTOR:**
1. PLUMBER TO PROVIDE TRAPS IN CEILING CONNECTED TO SEWER SYSTEM FOR CONDENSATE DRAINS - REFER TO DETAIL.
 2. CONDENSATE DRAINS FROM AC UNITS TO A TRAP IN CEILING BY AC CONTRACTOR.
 3. CONDENSATE DRAIN PIPES TO FOLLOW THE SHORTEST POSSIBLE ROUTE AS DETERMINED ON SITE. ACCEPTABLE FALL 1:80 MIN AND SIZES TO BE AS SHOWN ON PLAN LAYOUT.

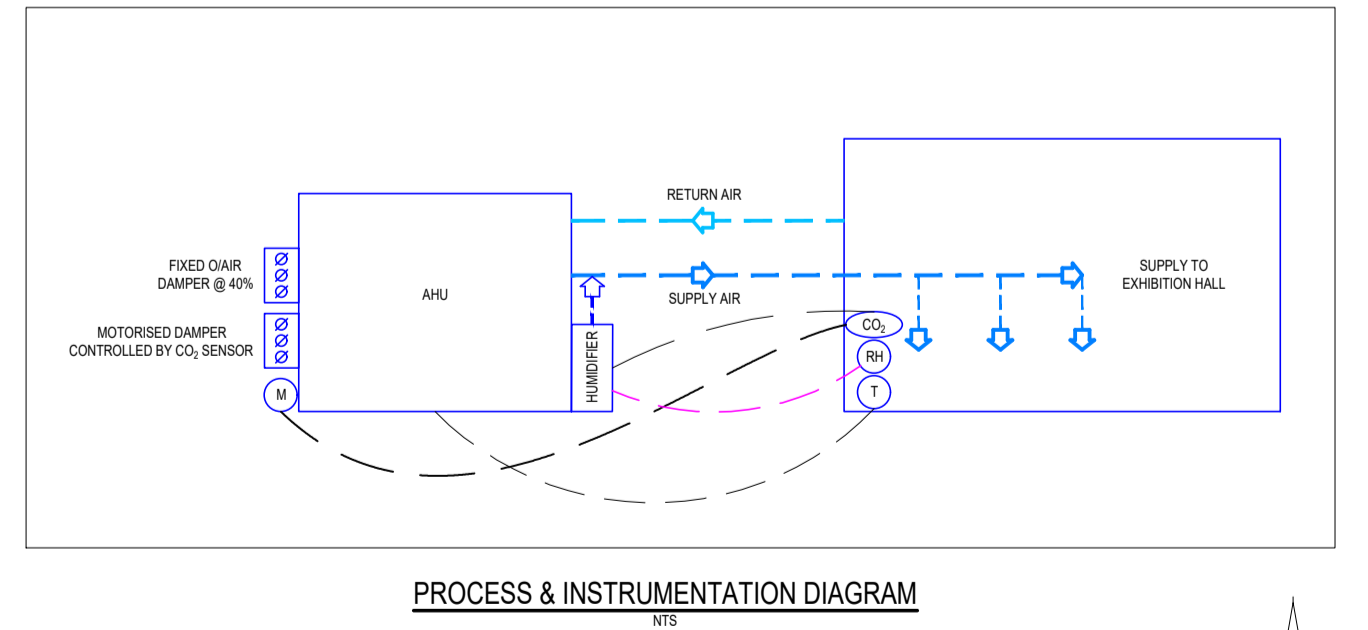
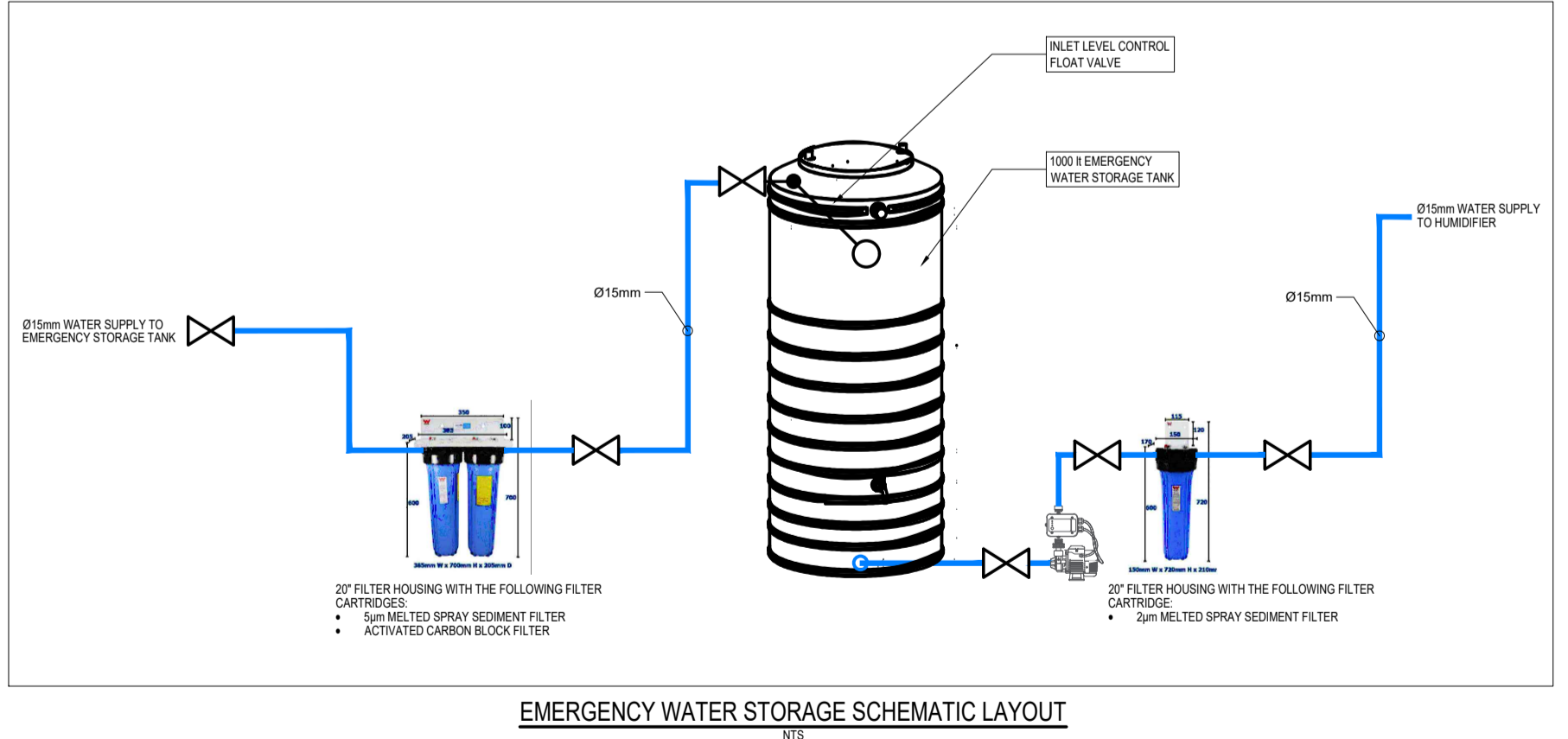
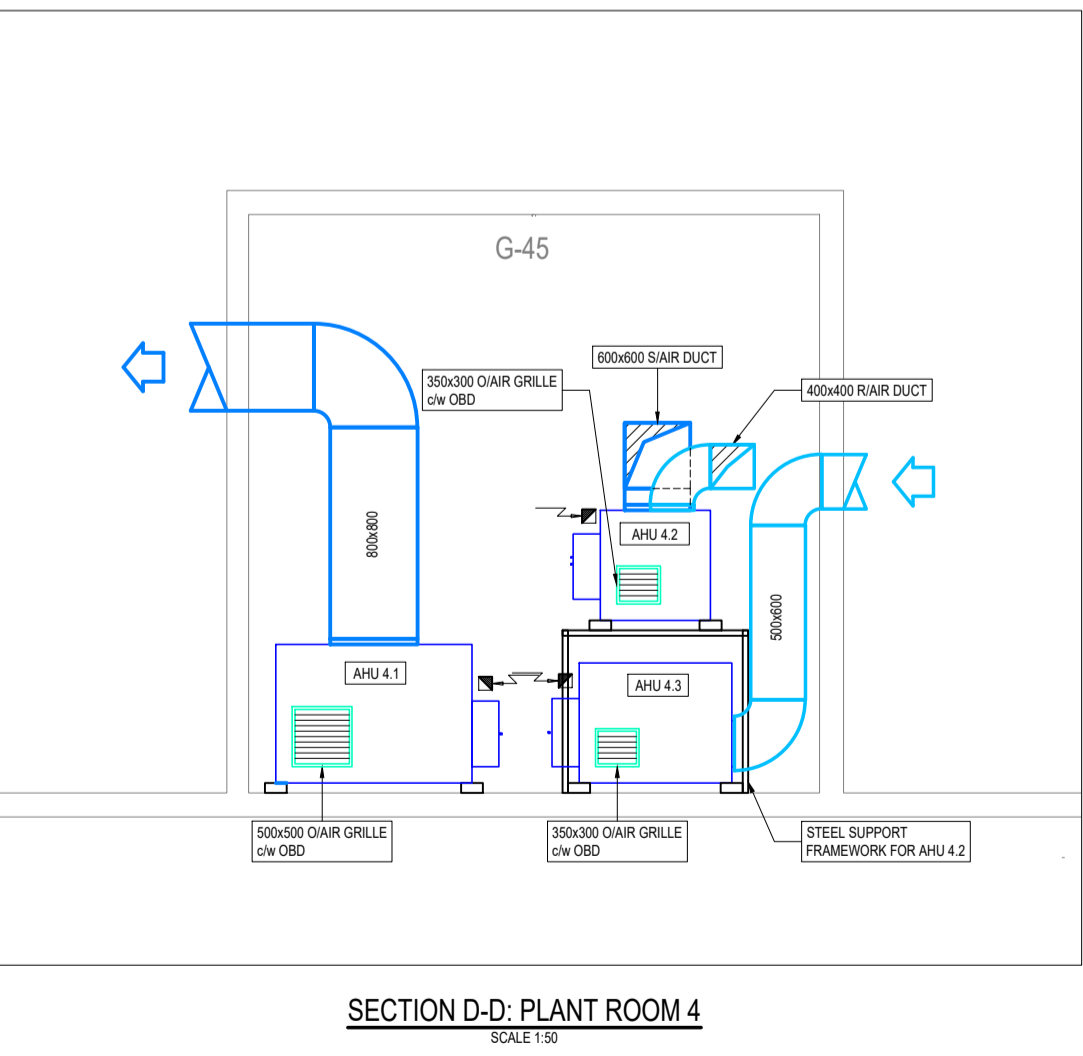
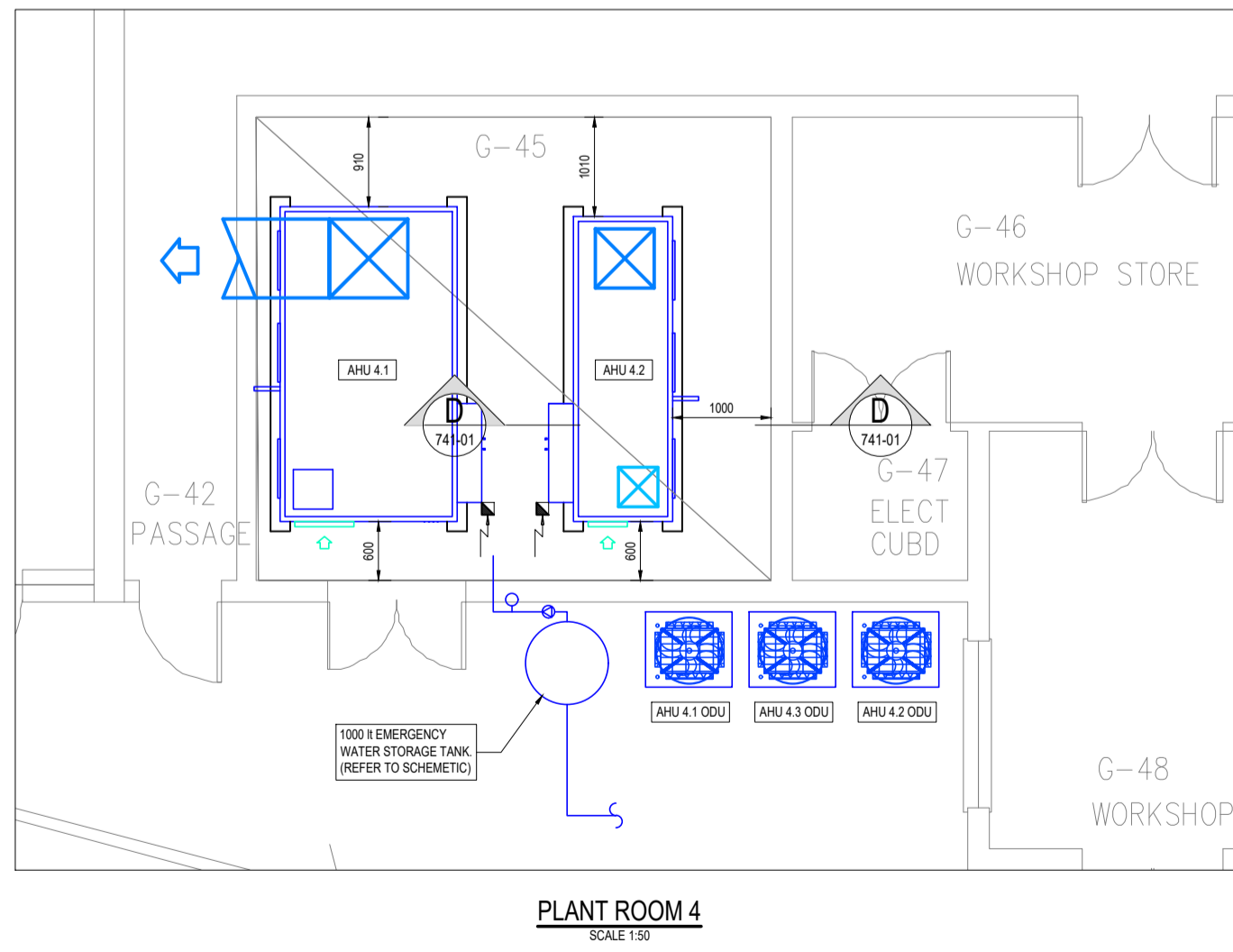
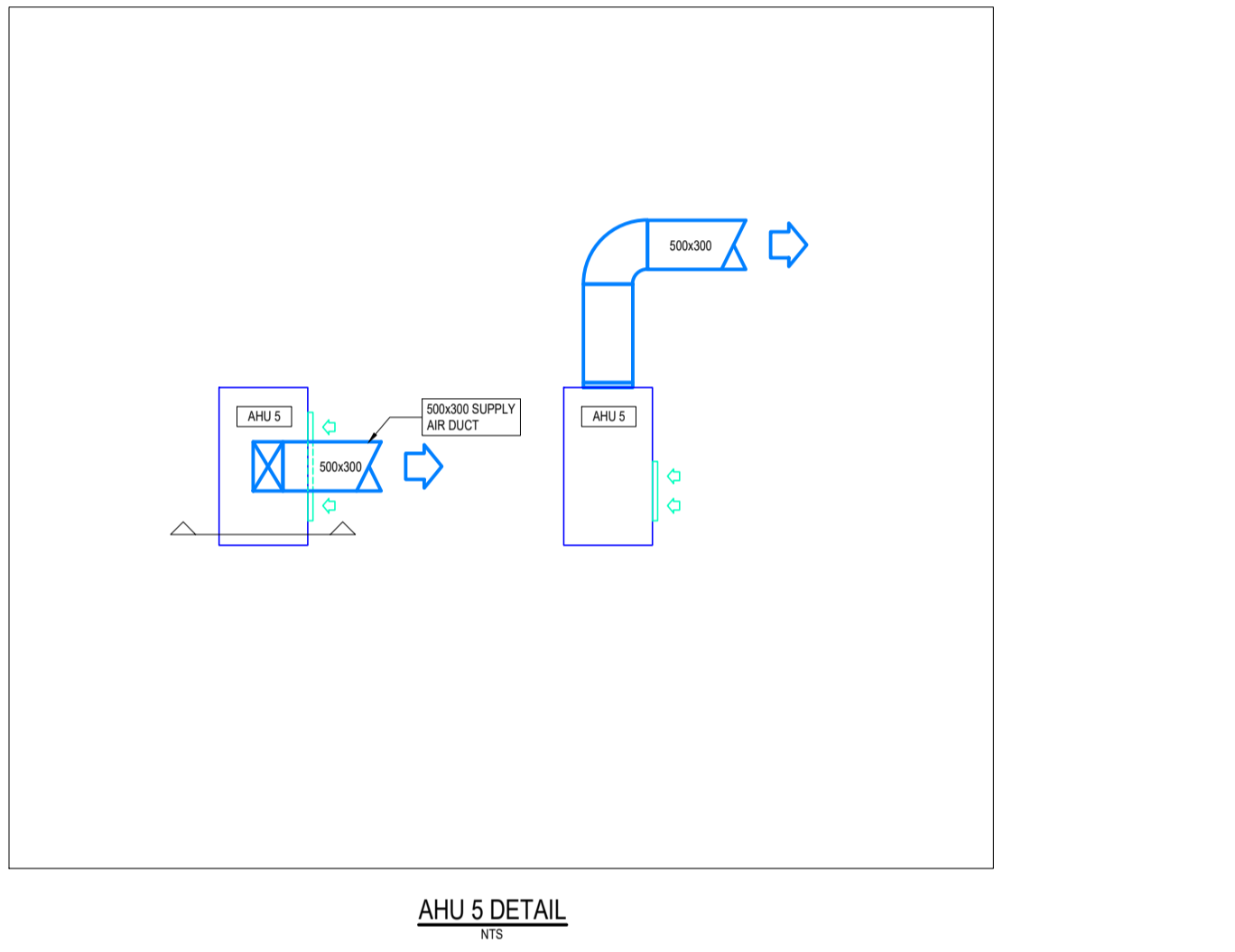
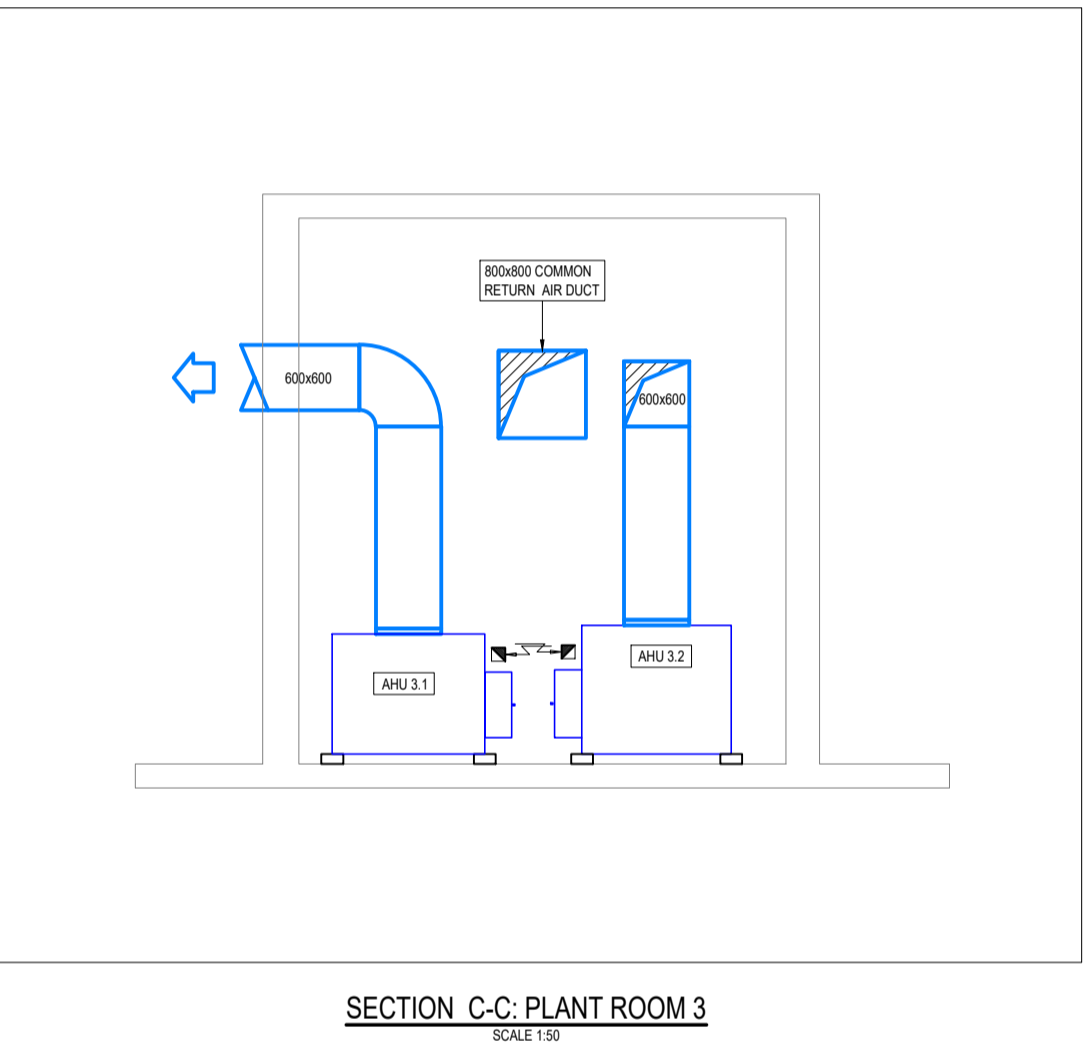
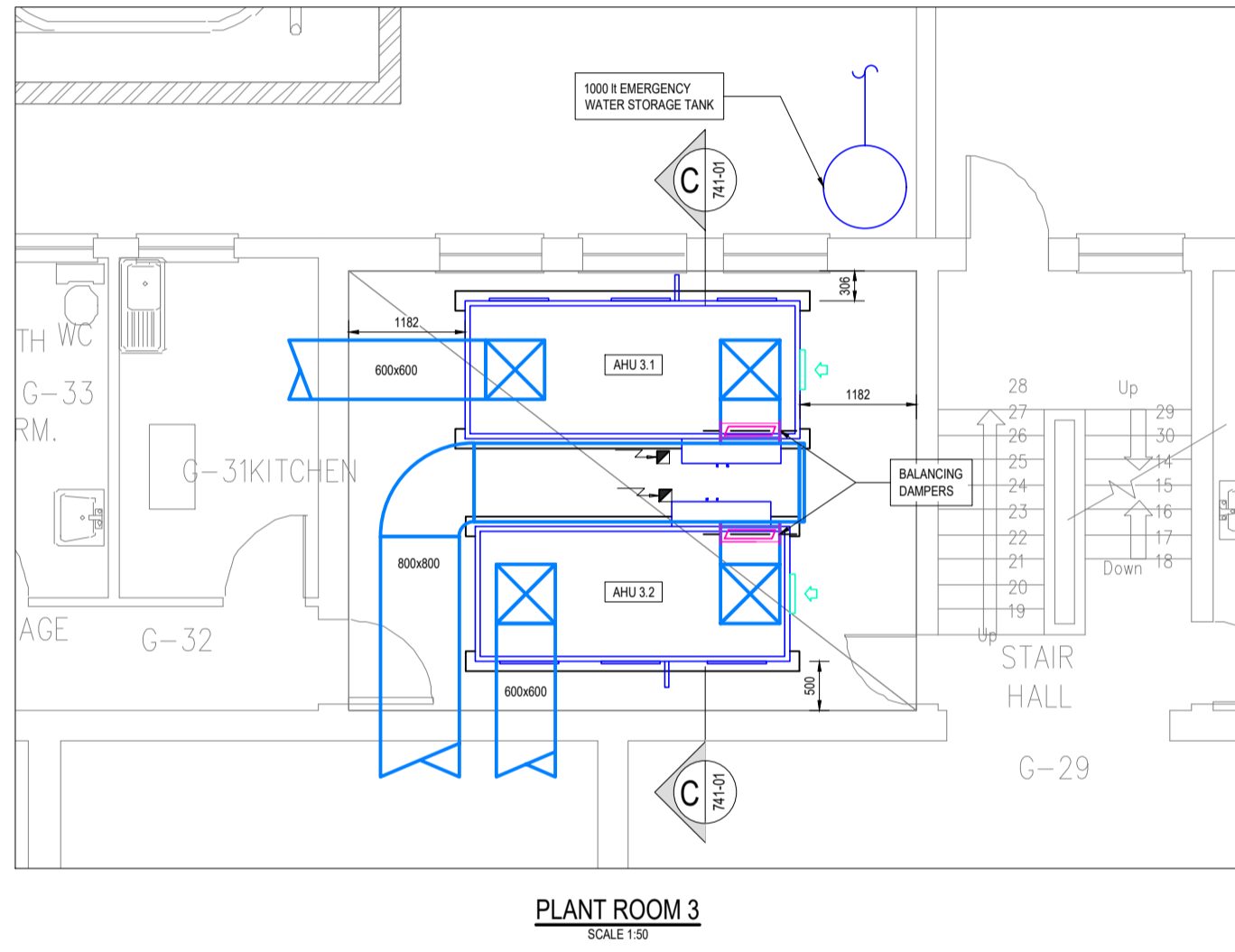
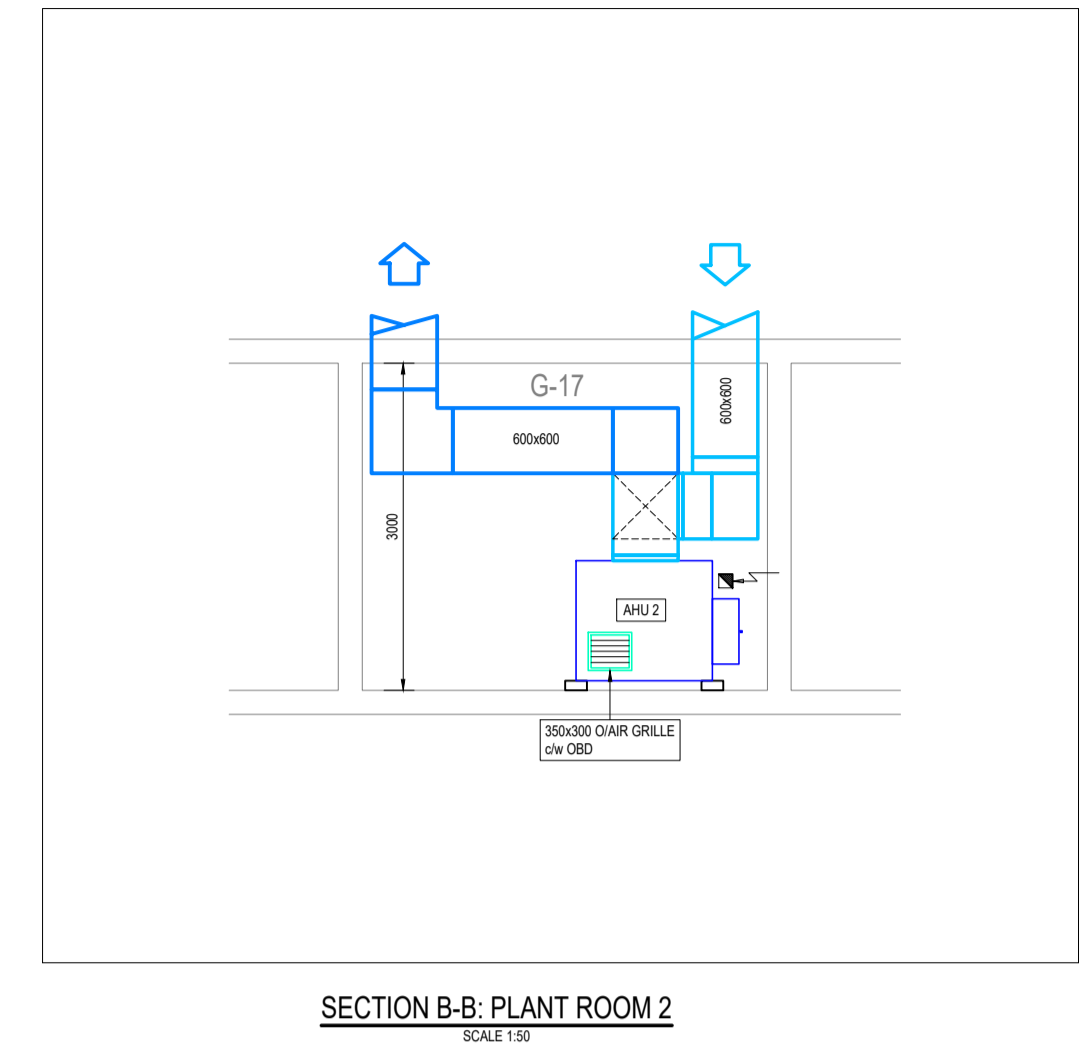
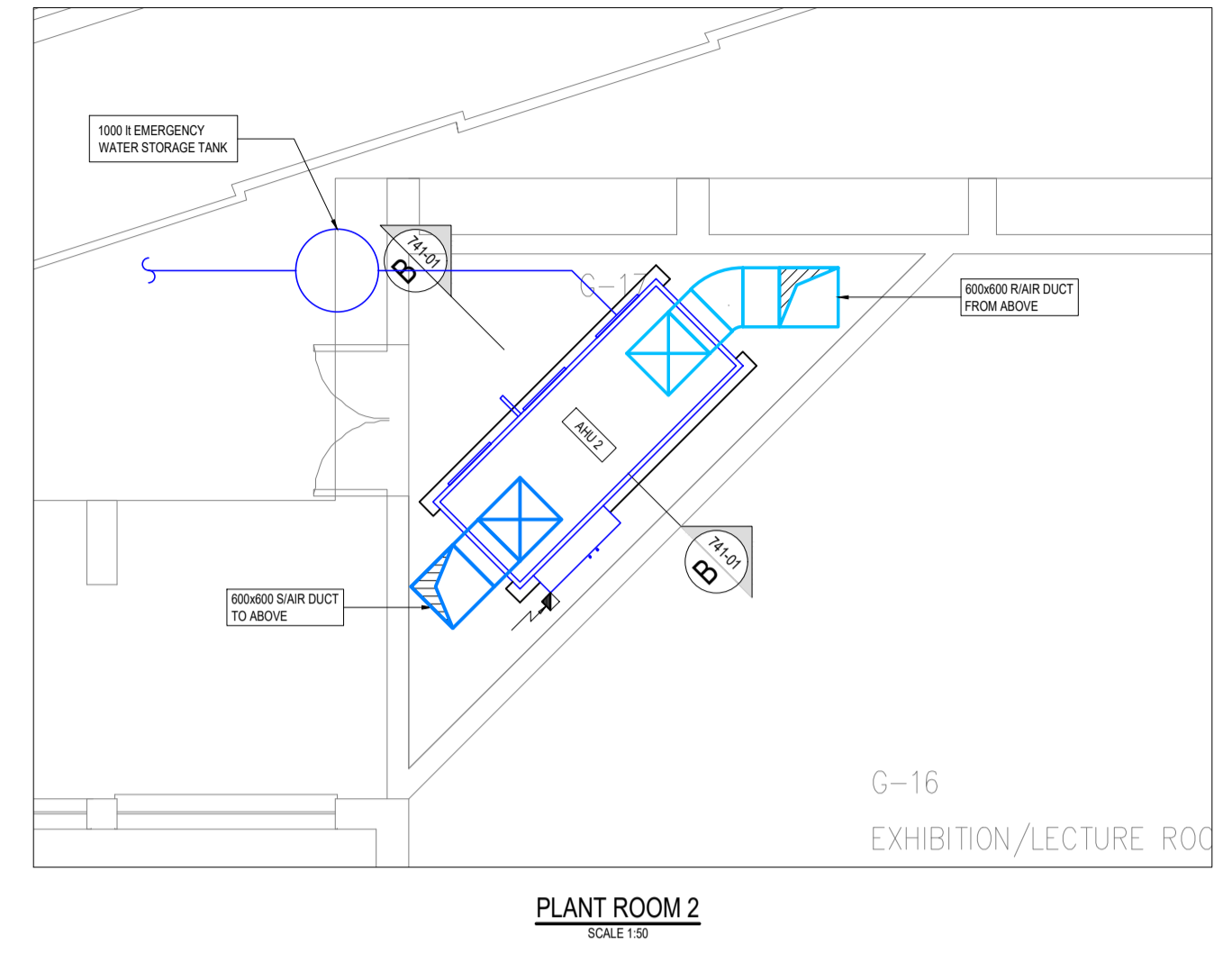
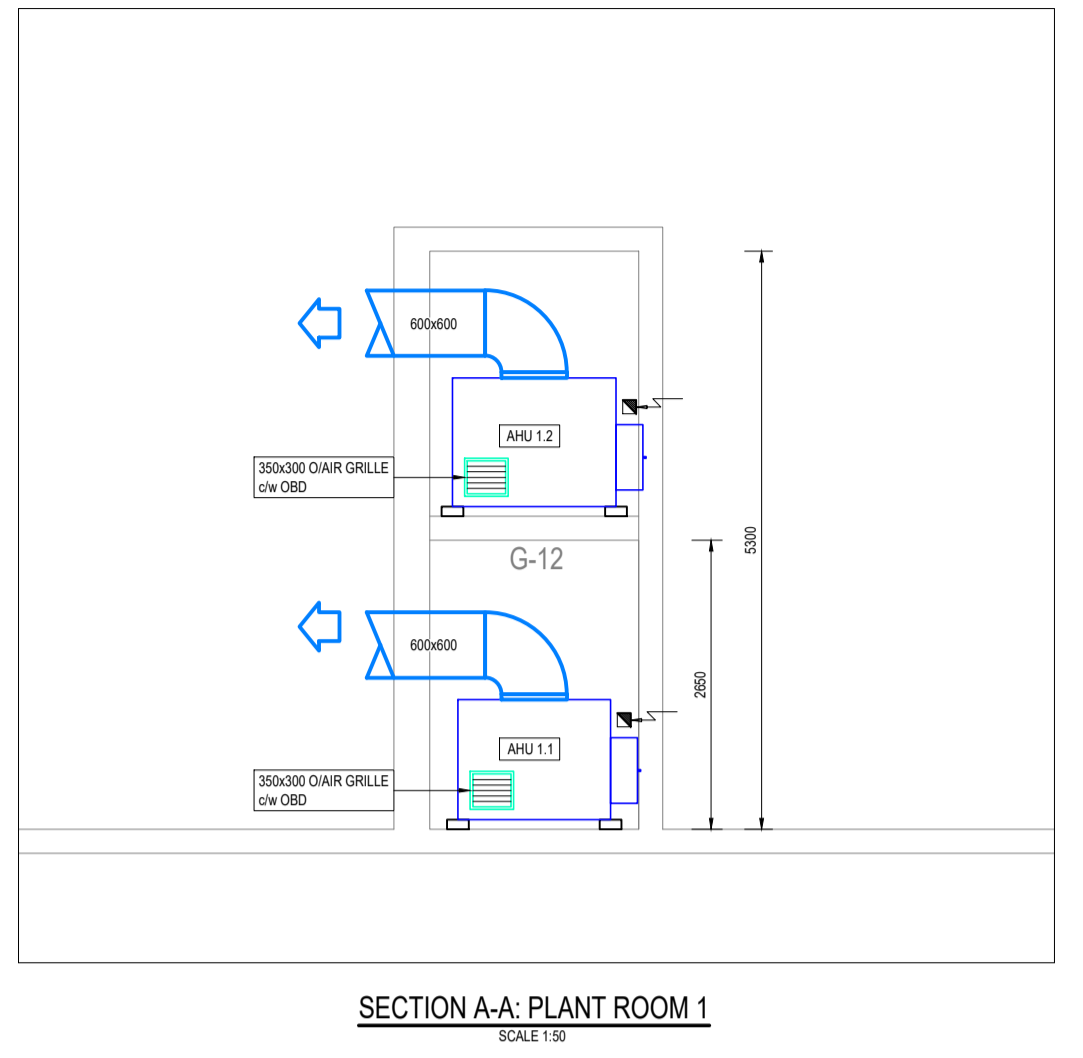
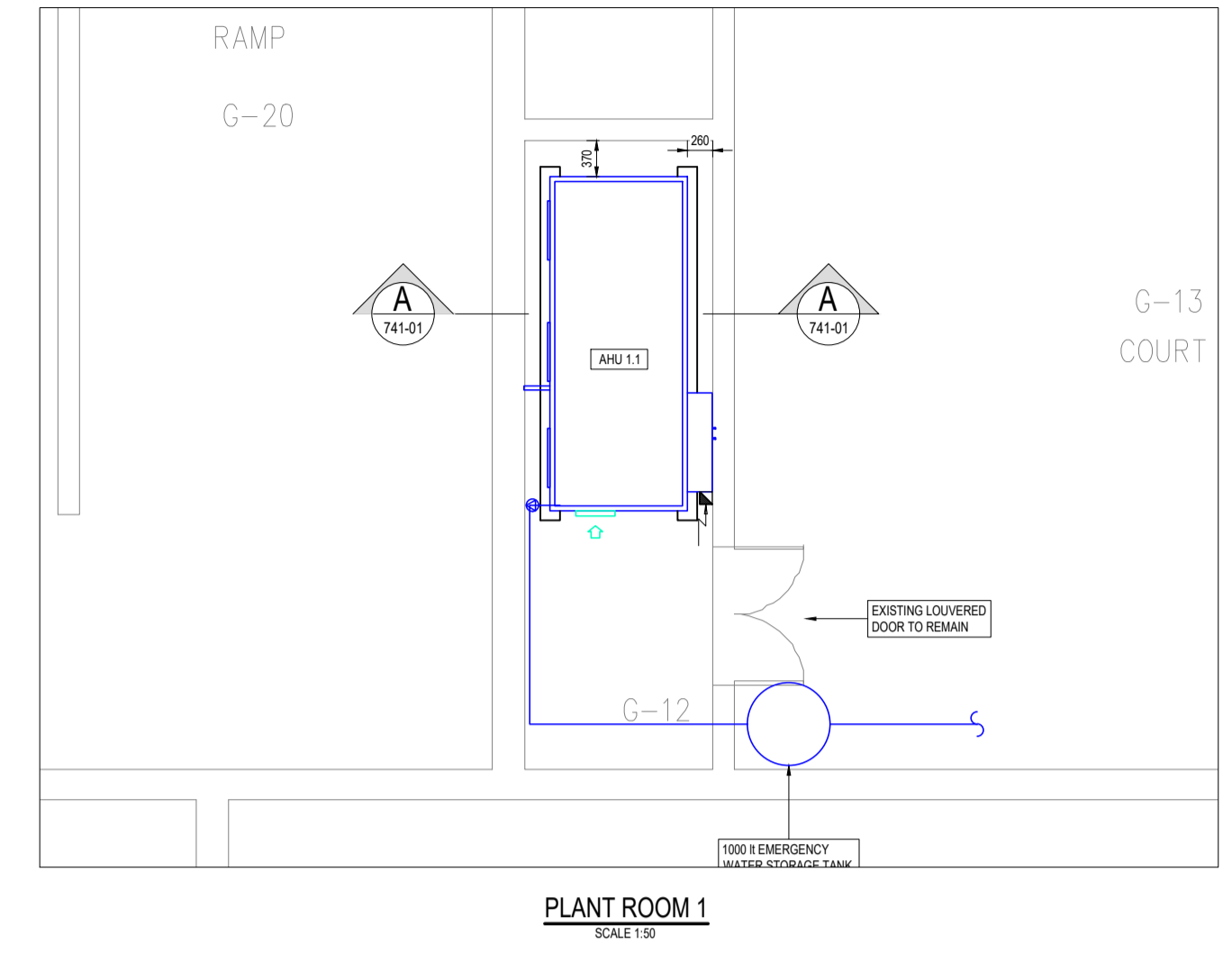

SYMBOL LEGEND

ISOLATOR AND ELECTRICAL SUPPLY 380VOLT 3-PHASE	FIRE DAMPER - MOTORISED SPRING RETURN
INDICATED DB BOARD	UNINSULATED DUCTING
ELECTRICAL POWER SUPPLY 220V SINGLE PHASE	INTERNALLY INSULATED DUCTING
DOORS TO BE UNDERCUT BY 20mm	EXTERNALLY LAGGED DUCTING
MANNS WATER SUPPLY - WITH GATE VALVE-SIZE AS NOTED	
DRAIN N6 100 CONNECTED INTO SEWER SYSTEM	
8000 TEMPERATURE SENSOR	
THERMOSTAT MASTER DIFFUSER	
REMOTE ON/OFF SWITCH - 100x100 WALL BOX WITH 25mm CONDUIT INTO CEILING VOID	

NOTES/LEGEND

SPLITTERS

150 TO 800	300
801 TO 900	300 555
901 TO 9250	250 400 750
1201 TO 2400	300 550 950
181 182 183	181 182 183
DUCT WIDTH (mm)	SPLITTER RADII (mm)

PROJECT STATUS

APPROVED BY COUNCIL / CLIENT

CITY ENGINEER / CLIENT REG. NO. DATE

AMENDMENTS CODE

A. BY CLIENT
B. BY ARCHITECT
C. BY MECHANICAL OR ELECTRICAL
D. BY I.M.
E. BY OTHER ()

REVISION DESCRIPTION

DATE	INITIAL	NO.	CODE	REVISION DESCRIPTION
15/03/2024	S.B.	AD		DRAWING ISSUED FOR INFORMATION

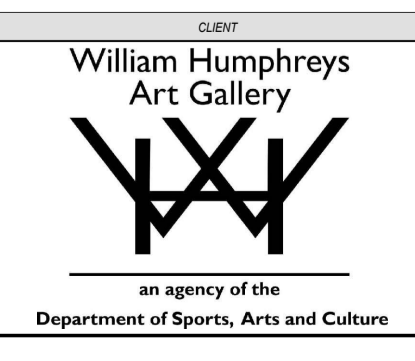

APPROVED BY

DESIGNED	AS SHOWN @ A1	DRAWN	S.BARNES
CHECKED	J. du PLESSIS	CHECKED	A.MALGAS
PLAN NUMBER	35129.00-741-02	REVISION NO.	A
DATE SAVED	15 March 2024		

PROJECT

WILLIAM HUMPHREYS ART GALLERY

DRAWING TITLE

HVAC LAYOUT

PROJECT

WILLIAM HUMPHREYS ART GALLERY

ENGINEER/TECHNOLOGIST REG. NO. DATE

20097002 15/03/2024

SCALE AS SHOWN @ A1

DESIGNED J. du PLESSIS

CHECKED A.MALGAS

PLAN NUMBER 35129.00-741-02

REVISION NO. A

DATE SAVED 15 March 2024