

DETAIL A, B & C

REV 1

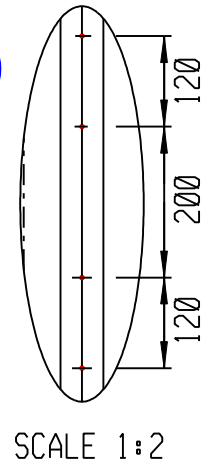

SCALE 1:2

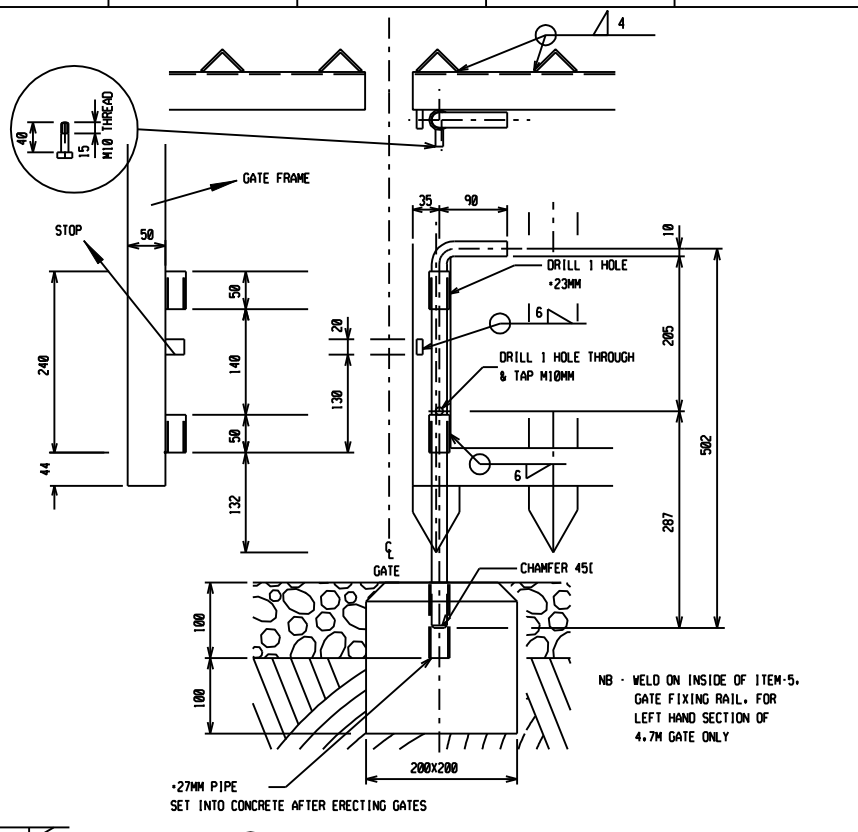
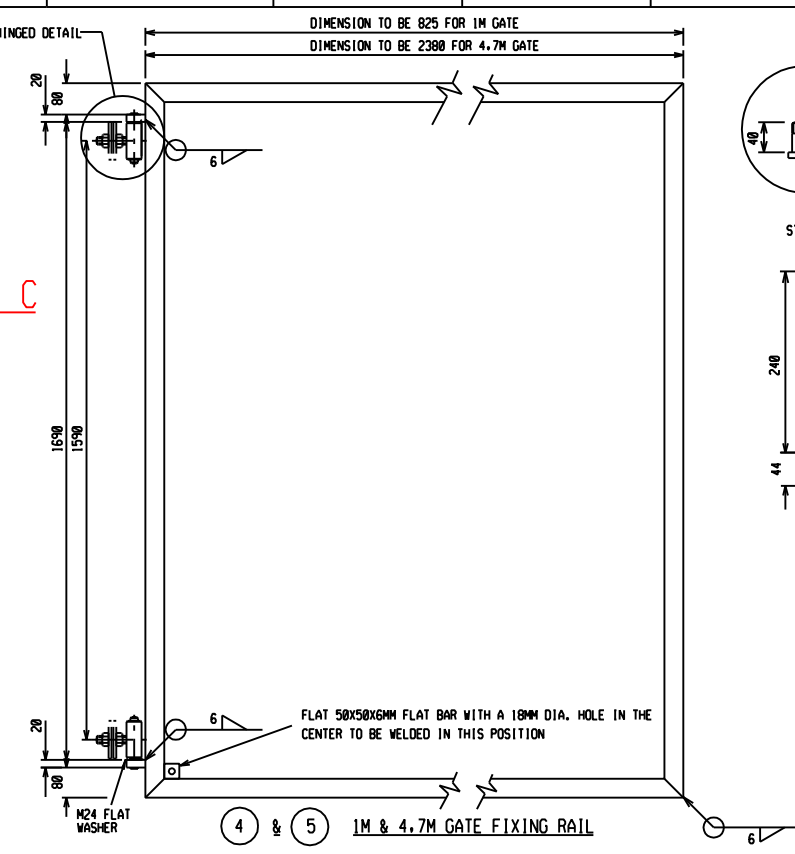

NOTE:
 1- ON 2M AND 3M PANEL 5MM DIA HOLES DRILLED IN THE CENTER PANEL FOR NOTICE & WARNING LABELS. SEE DETAIL A, B & C
 2- ON 4.7M GATE 5MM DIA HOLES DRILLED IN EVERY 2ND PANEL FOR NOTICE & WARNING LABELS. SEE DETAIL A, B & C

REV 1

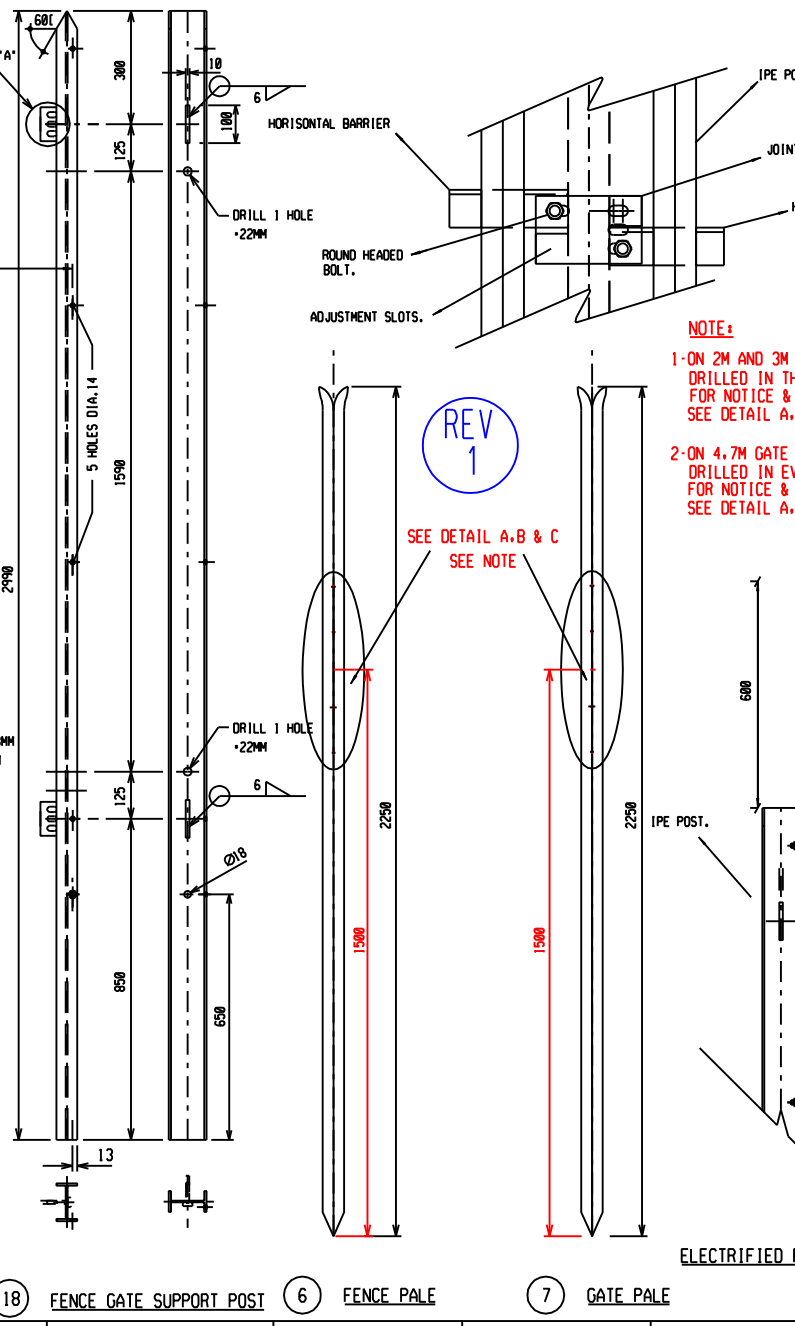

BOLT SIZE MM	PITCH MM	MILD STEEL BOLTS GRADE	TORQUE NM
16	2	4.8	100
20	2	4.8	200
24	3	4.8	300

- NOTES
- ALL WELDING AND WELDING SYMBOLS SHALL CONFORM TO SANS 10044 PART 1 TO 5.
 - ALL STRUCTURAL USE OF STEEL TO CONFORM TO SANS 10162. GRADE OF STEEL TO BE SANS 1431 GRADE 300MA.
 - ALL WELDS TO BE SEALED WELDED.
 - STEELWORK TO BE HOT DIP GALVANIZED TO SANS 121
 - ALL STEELWORK TO BE FABRICATED, ERECTED & LEVELED TO A TOLERANCE OF ± 1.5MM.
 - ALL BOLTS & NUTS TO CONFORM TO SABS 135, STRENGTH GRADE 4.8.
 - ALL MARKS TO BE STRAPPED ONTO STEELWORK AND SHALL BE CLEARLY LEGIBLE AFTER GALVANIZING.
 - ALL HOLES TO BE 18MM DIA, UNLESS OTHERWISE STATED.

THIS DRAWING IS THE NEW OFFICIAL REVISION. IT SUPERCEDES ALL OTHER PUBLISHED DRAWINGS.

REV	REVISION DESCRIPTION	BY	CHKD	AUTH	DATE	PROJECT NO.
1	FILES PROVIDED FOR MARK & WARNING LABELS. FENCE & GATE PALE CORRECTED.	D.J.P			/ / 2009	

DATE	BY	CHKD	AUTH	DATE
24/06/2009	JLR	DJP		12/06/2009

SET	SHEET	REVISION
	16	2



STANDARD SUBSTATION FENCING
 2.4M STEEL PALISADE FENCE
 STRUCTURAL DETAILS

2-ET-14899

16 2 1