

TRANSNET PORT TERMINALS

TENDER NUMBER: TPT/2024/03/0066/60631/RFP

DESCRIPTION OF THE SERVICES: FOR THE SUPPLY OF SERVICES TO REFURBISH STACKER RECLAIMER 3 AT THE SALDANHA IRON ORE TERMINAL FOR TRANSNET SOC LTD (REG.NO.1990/000900/30) OPERATING AS TRANSNET PORT TERMINALS, (HEREINAFTER REFERRED TO AS "TPT"), AS A ONCE OFF SUPPLY.



Transnet Port Terminals

an Operating Division **TRANSNET SOC LTD**

[Registration Number 1990/000900/30]

REQUEST FOR PROPOSAL (RFP)

FOR THE SUPPLY OF SERVICES TO REFURBISH STACKER RECLAIMER 3 AT THE SALDANHA IRON ORE TERMINAL FOR TRANSNET SOC LTD (REG.NO.1990/000900/30) OPERATING AS TRANSNET PORT TERMINALS, (HEREINAFTER REFERRED TO AS "TPT"), AS A ONCE OFF SUPPLY.

RFP NUMBER	: TPT/2024/03/0066/60631/RFP
ISSUE DATE	: 19 March 2024
NON-COMPULSORY BRIEFING	: 02 April 2024
CLOSING DATE	: 25 April 2024
CLOSING TIME	: 10h00am
TENDER VALIDITY PERIOD	: 12 weeks from closing date



Contents

Number Heading

The Tender

Part T1: Tendering Procedures

- T1.1 Tender Notice and Invitation to Tender
- T1.2 Tender Data

Part T2: Returnable Documents

- T2.1 List of Returnable Document
- T2.2 Returnable Schedules

The Contract

Part C1: Agreements and Contract Data

- C1.1 Form of Offer and Acceptance
- C1.2 Contract Data (Parts 1 & 2)
- C1.3 Form of Guarantee

Part C2: Pricing Data

- C2.1 Pricing Instructions
- C2.2 Activity Schedule

Part C3: Scope of Work

- C3.1 Works Information

Part C4: Site Information

- C4.1 Site Information



T1.1 TENDER NOTICE AND INVITATION TO TENDER

SECTION 1: NOTICE TO TENDERERS

1. INVITATION TO TENDER

Responses to this Tender [hereinafter referred to as a **Tender**] are requested from persons, companies, close corporations or enterprises [hereinafter referred to as a Tenderer].

DESCRIPTION	For the supply of services to refurbish stacker reclaimers 3 at the Saldanha Iron Ore Terminal for Transnet Soc Ltd (reg.no.1990/000900/30) operating as Transnet Port Terminals, (hereinafter referred to as "TPT"), as a once off supply.
TENDER DOWNLOADING	This Tender may be downloaded directly from the National Treasury eTender Publication Portal at www.etenders.gov.za and the Transnet website at https://transnetetenders.azurewebsites.net (please use Google Chrome to access Transnet link) FREE OF CHARGE.

NON-COMPULSORY TENDER CLARIFICATION MEETING	<p>A Non-compulsory Tender Clarification Meeting will be conducted via Microsoft teams on the 02 April 2024, at 10:00am [10 O'clock] for a period of ± 3 (three) hours.</p> <p>A non-compulsory Tender Clarification Meeting will start punctually and information will not be repeated for the benefit of Tenderers arriving late.</p> <p>Microsoft Teams meeting</p> <p>Microsoft Teams meeting</p> <p>Join on your computer, mobile app or room device</p> <p>Click here to join the meeting</p> <p>Meeting ID: 331 627 700 902</p> <p>Passcode: 4HMXHM</p> <p>Or call in (audio only)</p> <p>+27 21 835 5059,,640370945# South Africa, Cape Town</p> <p>Phone Conference ID: 640 370 945#</p> <p>Find a local number Reset PIN</p>
--	--



TRANSNET PORT TERMINALS

TENDER NUMBER: TPT/2024/03/0066/60631/RFP

DESCRIPTION OF THE SERVICES: FOR THE SUPPLY OF SERVICES TO REFURBISH STACKER RECLAIMER 3 AT THE SALDANHA IRON ORE TERMINAL FOR TRANSNET SOC LTD (REG.NO.1990/000900/30) OPERATING AS TRANSNET PORT TERMINALS, (HEREINAFTER REFERRED TO AS "TPT"), AS A ONCE OFF SUPPLY.

CLOSING DATE	10:00am on 25 April 2024 Tenderers must ensure that tenders are uploaded timeously onto the system. If a tender is late, it will not be accepted for consideration.
---------------------	--

2. TENDER SUBMISSION

Transnet has implemented a new electronic tender submission system, the e-Tender Submission Portal, in line with the overall Transnet digitalization strategy where suppliers can view advertised tenders, register their information, log their intent to respond to bids and upload their bid proposals/responses on to the system.

a) The Transnet e-Tender Submission Portal can be accessed as follows:

Log on to the Transnet eTenders management platform website (<https://transnetetenders.azurewebsites.net>);

- Click on "ADVERTISED TENDERS" to view advertised tenders;
- Click on "SIGN IN/REGISTER – for bidder to register their information (must fill in all mandatory information);
- Click on "SIGN IN/REGISTER" - to sign in if already registered;
- Toggle (click to switch) the "Log an Intent" button to submit a bid;
- Submit bid documents by uploading them into the system against each tender selected.
- **Tenderers are required to ensure that electronic bid submissions are done at least a day before the closing date to prevent issues which they may encounter due to their internet speed, bandwidth or the size of the number of uploads they are submitting. Transnet will not be held liable for any challenges experienced by bidders as a result of the technical challenges. Please do not wait for the last hour to submit. A Tenderer can upload 30mb per upload and multiple uploads are permitted.**

b) The tender offers to this tender will be opened as soon as possible after the closing date and time. Transnet shall not, at the opening of tenders, disclose to any other company any confidential details pertaining to the Tender Offers / information received, i.e. pricing, delivery, etc. The names and locations of the Tenderers will be divulged to other Tenderers upon request.

c) Submissions must not contain documents relating to any Tender other than that shown on the submission.

3. CONFIDENTIALITY

All information related to this RFP is to be treated with strict confidentiality. In this regard Tenderers are required to certify that they have acquainted themselves with the Non-Disclosure Agreement. All information related to a subsequent contract, both during and after completion thereof, will be treated with strict confidence. Should the need however arise to divulge any information gleaned from provision of the Works, which is either directly or indirectly related to Transnet's business, written approval to divulge such information must be obtained from Transnet.

4. DISCLAIMERS

Tenderers are hereby advised that Transnet is not committed to any course of action as a result of its issuance of this Tender and/or its receipt of a tender offer. In particular, please note that Transnet reserves the right to:

- 4.1. Award the business to the highest scoring Tenderer/s unless objective criteria justify the award to another tenderer.
- 4.2. Not necessarily accept the lowest priced tender or an alternative Tender;
- 4.3. Go to the open market if the quoted rates (for award of work) are deemed unreasonable;
- 4.4. Should the Tenderers be awarded business on strength of information furnished by the Tenderer, which after conclusion of the contract is proved to have been incorrect, Transnet reserves the right to terminate the contract;
- 4.5. Request audited financial statements or other documentation for the purposes of a due diligence exercise;
- 4.6. Not accept any changes or purported changes by the Tenderer to the tender rates after the closing date;
- 4.7. Verify any information supplied by a Tenderer by submitting a tender, the Tenderer/s hereby irrevocably grant the necessary consent to the Transnet to do so;
- 4.8. Conduct the evaluation process in parallel. The evaluation of Tenderers at any given stage must therefore not be interpreted to mean that Tenderers have necessarily passed any previous stage(s);
- 4.9. Unless otherwise expressly stated, each tender lodged in response to the invitation to tender shall be deemed to be an offer by the Tenderer. The Employer has the right in its sole and unfettered discretion not to accept any offer.



TRANSNET PORT TERMINALS

TENDER NUMBER: TPT/2024/03/0066/60631/RFP

DESCRIPTION OF THE SERVICES: FOR THE SUPPLY OF SERVICES TO REFURBISH STACKER RECLAIMER 3 AT THE SALDANHA IRON ORE TERMINAL FOR TRANSNET SOC LTD (REG.NO.1990/000900/30) OPERATING AS TRANSNET PORT TERMINALS, (HEREINAFTER REFERRED TO AS "TPT"), AS A ONCE OFF SUPPLY.

- 4.10. Not be held liable if tenderers do not provide the correct contact details during the clarification session and do not receive the latest information regarding this RFP with the possible consequence of being disadvantaged or disqualified as a result thereof.
- 4.11. Transnet reserves the right to exclude any Tenderers from the tender process who has been convicted of a serious breach of law during the preceding 5 [five] years including but not limited to breaches of the Competition Act 89 of 1998, as amended. Tenderers are required to indicate in tender returnable on T2.2-18], [**Breach of Law**] whether or not they have been found guilty of a serious breach of law during the past 5 [five] years.
- 4.12. Transnet reserves the right to perform a risk analysis on the preferred tenderer to ascertain if any of the following might present an unacceptable commercial risk to the employer:
 - *unduly high or unduly low tendered rates or amounts in the tender offer;*
 - *contract data of contract provided by the tenderer; or*
 - *the contents of the tender returnables which are to be included in the contract.*

5. Transnet will not reimburse any Tenderer for any preparatory costs or other work performed in connection with this Tender, whether or not the Tenderer is awarded a contract.

6. NATIONAL TREASURY’S CENTRAL SUPPLIER DATABASE

Tenderer are required to self-register on National Treasury’s Central Supplier Database (CSD) which has been established to centrally administer supplier information for all organs of state and facilitate the verification of certain key supplier information. The CSD can be accessed at <https://secure.csd.gov.za/>. Tenderer are required to provide the following to Transnet in order to enable it to verify information on the CSD:

Supplier Number..... and Unique registration reference number.....(**Tender Data**)

Transnet urges its clients, suppliers and the general public
to report any fraud or corruption to
TIP-OFFS ANONYMOUS: 0800 003 056 OR Transnet@tip-offs.com



TRANSNET PORT TERMINALS

TENDER NUMBER: TPT/2024/03/0066/60631/RFP

DESCRIPTION OF THE SERVICES: FOR THE SUPPLY OF SERVICES TO REFURBISH STACKER RECLAIMER 3 AT THE SALDANHA IRON ORE TERMINAL FOR TRANSNET SOC LTD (REG.NO.1990/000900/30) OPERATING AS TRANSNET PORT TERMINALS, (HEREINAFTER REFERRED TO AS "TPT"), AS A ONCE OFF SUPPLY.

T1.2 TENDER DATA

The conditions of tender are the Standard Conditions of Tender as contained in Annex C of the CIDB Standard for Uniformity in Engineering and Construction Works Contracts. The Standard for Uniformity in Construction Procurement was first published in Board Notice 62 of 2004 in Government Gazette No 26427 of 9 June 2004. It was subsequently amended in Board Notice 67 of 2005 in Government Gazette No 28127 of 14 October 2005, Board Notice 93 of 2006 in Government Gazette No 29138 of 18 August 2006, Board Notice No 9 of 2008 in Government Gazette No 31823 of 30 January 2009, Board Notice 86 of 2010 in Government Gazette No 33239 of 28 May 2010, Board Notice 136 of 2015 in Government Gazette 38960 of 10 July 2015 and Board Notice 423 of 2019 in Government Gazette No 42622 of 8 August 2019.

This edition incorporates the amendments made in Board Notice 423 of 2019 in Government Gazette 42622 of 8 August 2019. (see www.cidb.org.za).

The Standard Conditions of Tender make several references to Tender data for detail that apply specifically to this tender. The Tender Data shall have precedence in the interpretation of any ambiguity or inconsistency between it and the Standard Conditions of Tender.

Each item of data given below is cross-referenced in the left-hand column to the clause in the Standard Conditions of Tender to which it mainly applies.

Clause	Data
C.1.1	The <i>Employer</i> is Transnet SOC Ltd (Reg No. 1990/000900/30) operating as Transnet Port Terminals
C.1.2	The tender documents issued by the <i>Employer</i> comprise: Part T: The Tender Part T1: Tendering procedures Part T2 : Returnable documents Part C: The contract Part C1: Agreements and contract data Part C2: Pricing data
	T1.1 Tender notice and invitation to tender T1.2 Tender data T2.1 List of returnable documents T2.2 Returnable schedules C1.1 Form of offer and acceptance C1.2 Contract data (Part 1 & 2) C1.3 Form of Securities C2.1 Pricing instructions C2.2 Activity Schedule

TRANSNET PORT TERMINALS

TENDER NUMBER: TPT/2024/03/0066/60631/RFP

DESCRIPTION OF THE SERVICES: FOR THE SUPPLY OF SERVICES TO REFURBISH STACKER RECLAIMER 3 AT THE SALDANHA IRON ORE TERMINAL FOR TRANSNET SOC LTD (REG.NO.1990/000900/30) OPERATING AS TRANSNET PORT TERMINALS, (HEREINAFTER REFERRED TO AS "TPT"), AS A ONCE OFF SUPPLY.

Part C3: Scope of work C3.1 Works Information

Part C4: Site information C4.1 Site information

C.1.4	The Employer's agent is:	Strategic Sourcing Specialist
	Name:	Hlengiwe Zulu
	Address:	Transnet Port Terminals 202 Anton Lembede Street Durban 4000
	Tel No.	031 361 1034
	E – mail	Hlengiwe.Zulu@transnet.net

C.2.1

1. Step One: Test for Administrative Responsiveness

Administrative responsiveness check
• Whether the Bid has been lodged on time
• Whether all Returnable Documents and/or schedules [where applicable] were completed and returned by the closing date and time
• Verify the validity of all returnable documents
• Verify if the Bid document has been duly signed by the authorised respondent

The test for administrative responsiveness [Step One] must be passed for a Respondent's Proposal to progress to Step Two for further pre-qualification.

2. Step Two: Test for Substantive Responsiveness to RFP

The test for substantive responsiveness to this RFP will include the following:

Check for substantive responsiveness
• Whether any general pre-qualification criteria set by Transnet, have been met
• Whether the Bid contains a priced offer
• Whether the Bid materially complies with the scope and/or specification given

The test for substantive responsiveness [Step Two] must be passed for a Respondent's Proposal to progress to Step Three for further evaluation.



TRANSNET PORT TERMINALS

TENDER NUMBER: TPT/2024/03/0066/60631/RFP

DESCRIPTION OF THE SERVICES: FOR THE SUPPLY OF SERVICES TO REFURBISH STACKER RECLAIMER 3 AT THE SALDANHA IRON ORE TERMINAL FOR TRANSNET SOC LTD (REG.NO.1990/000900/30) OPERATING AS TRANSNET PORT TERMINALS, (HEREINAFTER REFERRED TO AS "TPT"), AS A ONCE OFF SUPPLY.

3. Step three - Functionality:

Only those tenderers who obtain the minimum qualifying score for functionality will be evaluated further in terms of price and the applicable preference point system. The minimum qualifying for score for functionality is **80** points.

The evaluation criteria for measuring functionality and the points for each criteria and, if any, each sub-criterion are as stated in C3.11 below.

Any tenderer that fails to meet the stipulated pre-qualifying criteria will be regarded as an unacceptable tender.

C.2.7 The arrangements for a compulsory clarification meeting are as stated in the Tender Notice and Invitation to Tender.

C.2.12 No alternative tender offers will be considered.

C.2.13.3 Each tender offer shall be in the **English Language**.

C.2.13.5 The *Employer's* details and identification details that are to be shown on each tender offer are as follows:

- | | |
|-------------------------|--|
| Identification details: | <p>The tender documents must be uploaded with:</p> <ul style="list-style-type: none"> ▪ Name of Tenderer..... ▪ Contact person and details..... ▪ The Tender Number: TPT/2024/03/0066/60631/RFP ▪ The Tender Description: for the supply of services to refurbish stacker reclaimer 3 at the Saldanha Iron Ore Terminal for Transnet Soc Ltd (reg.no.1990/000900/30) operating as Transnet Port Terminals, (hereinafter referred to as "TPT"), as a once off supply. |
|-------------------------|--|

Documents must be marked for the attention of:
Employer's Agent: Hlengiwe Zulu

C.2.13.9 Telephonic, telegraphic, facsimile or e-mailed tender offers will not be accepted.

C.2.15 The closing time for submission of tender offers is:
Time: **10:00am** on the **25 April 2024**
Location: The Transnet e-Tender Submission Portal:
(<https://transnetetenders.azurewebsites.net>);

NO LATE TENDERS WILL BE ACCEPTED



TRANSNET PORT TERMINALS

TENDER NUMBER: TPT/2024/03/0066/60631/RFP

DESCRIPTION OF THE SERVICES: FOR THE SUPPLY OF SERVICES TO REFURBISH STACKER RECLAIMER 3 AT THE SALDANHA IRON ORE TERMINAL FOR TRANSNET SOC LTD (REG.NO.1990/000900/30) OPERATING AS TRANSNET PORT TERMINALS, (HEREINAFTER REFERRED TO AS "TPT"), AS A ONCE OFF SUPPLY.

C.2.16 The tender offer validity period is **12 weeks** after the closing date. Tenderers are to note that they may be requested to extend the validity period of their tender, on the same terms and conditions, if Transnet's internal evaluation and governance approval processes has not been finalised within the validity period.

C.2.23 The tenderer is required to submit with his tender:

1. A valid Tax Clearance Certificate issued by the South African Revenue Services.
Tenderers also to provide Transnet with a TCS PIN to verify Tenderers compliance status.
2. A **valid B-BBEE Certificate** from a Verification Agency accredited by the South African Accreditation System [**SANAS**], or a **sworn affidavit** confirming annual turnover and level of black ownership, in line with the code of good practice, together with the tender;
3. Proof of registration on the Central Supplier Database;
4. Letter of Good Standing with the Workmen's compensation fund by the tendering entity or separate Letters of Good Standing from all members of a newly constituted JV.

Note: Refer to Section T2.1 for List of Returnable Documents

C3.11 The minimum number of evaluation points for functionality is: **80**

The procedure for the evaluation of responsive tenders is Functionality, Price and Preference:

Only those tenderers who attain the minimum number of evaluation points for Functionality will be eligible for further evaluation, failure to meet the minimum threshold will result in the tender being disqualified and removed from any further consideration.

Functionality Criteria

The functionality criteria and maximum score in respect of each of the criteria are as follows:

Eval uatio n Crite ria	Descriptio n	Scoring principal (The returnable schedules contains the details for scoring the points indicated in the column below)	Returnable Schedule	Criteria	Weighting	
Technical & Operational	Quality Management	Contractor to supply the following: Project Quality Management plan - 4 points Quality data book index - 1 point Index/List of procedures and method statements - 10 points Quality Control Plans - 3 points Quality Policy - 3 points Audit Schedule - 1 point Total of 22 points awarded for quality as a sum of the above individually scored areas	T2.2-01	Completed returnable	22	
	Sub-total				22	
	Organogram & CV's	Organogram		T2.2-02	Completed returnable	2
		Project Manager. Qualifications and experience - 7 points		T2.2-02	Completed returnable	7
		Construction Manager. Qualifications and experience - 5 points		T2.2-02	Completed returnable	5
		Health and Safety Officers Qualifications and experience - 3 points		T2.2-02	Completed returnable	3
		Quality Manager Qualifications and experience - 4 points		T2.2-02	Completed returnable	4
		Schedule Manager/Planner Experience - 2 points		T2.2-02	Completed returnable	2
		Commissioning Manager Qualifications and experience - 4 points		T2.2-02	Completed returnable	4
		Administration/Document Controller Experience - 1 point		T2.2-02	Completed returnable	1
	Sub-total				28	
	Availability of Equipment and other resources	Equipment indicated as a minimum must include for a low bed Truck, Scaffolding, Cranes 120t & 90t, Cherrypicker and Generator.		T2.2-03	Completed returnable	5

TRANSNET PORT TERMINALS

TENDER NUMBER: TPT/2024/03/0066/60631/RFP

DESCRIPTION OF THE SERVICES: FOR THE SUPPLY OF SERVICES TO REFURBISH STACKER RECLAIMER 3 AT THE SALDANHA IRON ORE TERMINAL FOR TRANSNET SOC LTD (REG.NO.1990/000900/30) OPERATING AS TRANSNET PORT TERMINALS, (HEREINAFTER REFERRED TO AS "TPT"), AS A ONCE OFF SUPPLY.

		No Response or Equipment indicated does not meet the minimum requirements. 0 points Equipment/availability meet the minimum requirements.5 points			
	Sub-total				5
	Evaluation Schedule: Programme	Ability to execute the works in terms of the Employer's requirements, indicating the order and timing of all activities that will take place in order to provide the works in the shortest possible duration. - 19 points Tender document provided in MS Projects format. 1 point Total of 20 points for schedule awarded as a sum of the above individually scored areas	T2.2-04	Completed returnable	20
	Sub total				20
Previous Experience	Previous Experience	Substantive experience of a successful refurbishment project of similar works specific to bulk material handling Stackers/Reclaimers: No experience: 0 points One (1) successful refurbishment project of at least R10m within last 10 years: 5 points One (1) successful refurbishment project of at least R20m within last 10 years: 10 points Two (2) successful refurbishment projects of at least R20m within last 10 years: 15 points Three (3) successful refurbishment projects of at least R20m within last 10 years: 20 points At least four (4) successful refurbishment projects of at least R20m within last 10 years: 25 points	T2.2-05	Completed returnable	25
	Sub total				25
	TOTAL RATING				100



TRANSNET PORT TERMINALS

TENDER NUMBER: TPT/2024/03/0066/60631/RFP

DESCRIPTION OF THE SERVICES: FOR THE SUPPLY OF SERVICES TO REFURBISH STACKER RECLAIMER 3 AT THE SALDANHA IRON ORE TERMINAL FOR TRANSNET SOC LTD (REG.NO.1990/000900/30) OPERATING AS TRANSNET PORT TERMINALS, (HEREINAFTER REFERRED TO AS "TPT"), AS A ONCE OFF SUPPLY.

Functionality shall be scored independently by not less than 3 (three) evaluators and averaged in accordance with the following schedules:

- T2.2- 01 Quality Management
- T2.2- 02 Project Organogram &CV's
- T2.2- 03 Availability of Equipment and other resources
- T2.2-04 Programme
- T2.2-05 Previous experience

Each evaluation criteria will be assessed in terms of scores of 0, 20, 40, 60, 80 or 100

The scores of each of the evaluators will be averaged, weighted and then totalled to obtain the final score for functionality, unless scored collectively. (See CIDB Inform Practice Note #9).

Note: Any tender not complying with the above mentioned requirements, will be regarded as non-responsive and will therefore not be considered for further evaluation. This note must be read in conjunction with Clause C.2.1.

C.3.11. Only tenders that achieve the minimum qualifying score for functionality will be evaluated further in accordance with the 90/10 preference points systems as described in Preferential Procurement Regulations.

90 where the financial value of one or more responsive tenders received have a value equal to or above R50 million, inclusive of all applicable taxes.

Thresholds	Minimum Threshold
Technical / functionality	80

Evaluation Criteria	Final Weighted Scores
Price	90
Specific goals - Scorecard	10
TOTAL SCORE:	100

Up to 100 minus W_1 tender evaluation points will be awarded to tenderers who complete the preferencing schedule and who are found to be eligible for the preference claimed. **Should the evidence required for any of the Specific Goals applicable in this tender not be provided, a tenderer will score zero preference points for that particular "Specific Goal".**

In terms of Transnet Preferential Procurement Policy (TPPP) and Procurement Manuals, the following preference points must be awarded to a bidder who provides the relevant required evidence for claiming points

Selected Specific Goal	Number of points allocated (10)
B-BBEE Level of contributor – Level 1&2	4
Subcontracting 30% of the value of the contract to EME's and QSE's 51%	4
Local content	2
TOTAL	10

The following Table represents the evidence to be submitted for claiming preference points for applicable specific goals in a particular tender:

TRANSNET PORT TERMINALS

TENDER NUMBER: TPT/2024/03/0066/60631/RFP

DESCRIPTION OF THE SERVICES: FOR THE SUPPLY OF SERVICES TO REFURBISH STACKER RECLAIMER 3 AT THE SALDANHA IRON ORE TERMINAL FOR TRANSNET SOC LTD (REG.NO.1990/000900/30) OPERATING AS TRANSNET PORT TERMINALS, (HEREINAFTER REFERRED TO AS "TPT"), AS A ONCE OFF SUPPLY.

Specific Goals	Acceptable Evidence
B-BBEE	B-BBEE Certificate / Sworn-Affidavit B-BBEE Certificate (in case of JV, a consolidate scorecard will be accept) as per DTIC guidelines
Local Content and Local Production	Returnable Local Content and production Annexures
<p>The promotion of supplier development through sub-contracting or JV for a minimum of 30% of the value of a contract to South African Companies which are:</p> <ul style="list-style-type: none"> I. 30% Black Women, 51% black Youth and 51% people with disabilities II. Entities with a specified minimum B-BBEE level (1 and 2) III. EMEs and/or QSEs who are 51% black-owned 	Sub-contracting agreements and Declaration / Joint Venture Agreement. Certified copy of ID Documents of the Owners and B-BBEE Certificate / Affidavit (in case of JV, a consolidate scorecard will be accept) of the sub-contracted entities.

The maximum points for this bid are allocated as follows:

<u>DISCRIPTION</u>	<u>POINTS</u>
PRICE	90
B-BBEE STATUS LEVEL OF CONTRIBUTION Level 1-2 =4	10
Subcontracting 30% of the value of the contract to EME's and QSE's 51% =4	
Local Content =2	
Total points for Price and Specific Goals must not exceed	100

Note: Transnet reserves the right to carry out an independent audit of the tenderers scorecard components at any stage from the date of close of the tenders until completion of the contract.

C.3.13 Tender offers will only be accepted if:

1. The tenderer or any of its directors/shareholders is not listed on the Register of Tender Defaulters in terms of the Prevention and Combating of Corrupt

-
- Activities Act of 2004 as a person prohibited from doing business with the public sector;
2. the tenderer does not appear on Transnet's list for restricted tenderers and National Treasury's list of Tender Defaulters;
 3. the tenderer has fully and properly completed the Compulsory Enterprise Questionnaire and there are no conflicts of interest which may impact on the tenderer's ability to perform the contract in the best interests of the Employer or potentially compromise the tender process and persons in the employ of the state.
 4. Transnet reserves the right to award the tender to the tenderer who scores the highest number of points overall, unless there are **objective criteria** which will justify the award of the tender to another tenderer. Objective criteria include but are not limited to the outcome of a due diligence exercise to be conducted. The due diligence exercise may take the following factors into account inter alia;
the tenderer:
 - a) is not under restrictions, or has principals who are under restrictions, preventing participating in the employer's procurement,
 - b) is not undergoing a process of being restricted by Transnet or other state institution that Transnet may be aware of,
 - c) can, as necessary and in relation to the proposed contract, demonstrate that he or she possesses the professional and technical qualifications, professional and technical competence, financial resources, equipment and other physical facilities, managerial capability, reliability, experience and reputation, expertise and the personnel, to perform the contract,
 - d) has the legal capacity to enter into the contract,
 - e) is not insolvent, in receivership, under Business Rescue as provided for in chapter 6 of the Companies Act, 2008, bankrupt or being wound up, has his affairs administered by a court or a judicial officer, has suspended his business activities, or is subject to legal proceedings in respect of any of the foregoing,
 - f) complies with the legal requirements, if any, stated in the tender data and
 - g) is able, in the option of the employer to perform the contract free of conflicts of interest.

C.3.17 The number of paper copies of the signed contract to be provided by the Employer is 1 (one).

T2.1 List of Returnable Documents

2.1.2 Stage three as per CIDB: these schedules will be utilised for evaluation purposes:

- T2.2-01 **Evaluation Schedule:** Quality Management
- T2.2-02 **Evaluation Schedule:** Project Organogram &CV's
- T2.2-03 **Evaluation Schedule:** Availability of Equipment and other resources
- T2.2-04 **Evaluation Schedule :** Schedule
- T2.2-05 **Evaluation Schedule:** Previous experience

2.1.3 Returnable Schedules:

General:

- T2.2-06 Authority to submit tender
- T2.2-07 Record of addenda to tender documents
- T2.2-08 Letter of Good Standing
- T2.2-09 Risk Elements
- T2.2-10 Subcontracting Form
- T2.2-11 Local Content
- T2.2-12 BBBEE
- T2.2-13 Site Establishment requirements
- T2.2-14 Professional Registration

Agreement and Commitment by Tenderer:

- T2.2-15: CIDB SFU ANNEX G Compulsory Enterprise Questionnaire
- T2.2-16 Non-Disclosure Agreement
- T2.2-17 RFP Declaration Form
- T2.2-18 RFP – Breach of Law
- T2.2-19 Certificate of Acquaintance with Tender Document
- T2.2-20 Service Provider Integrity Pact
- T2.2-21 Supplier Code of Conduct
- T2.2-22 Agreement in terms of Protection of Personal Information Act, 4 of 2013 ("POPIA")

2.1.4 Bonds/Guarantees/Financial/Insurance:

- T2.2-23 Insurance provided by the Contractor
- T2.2-24 Form of Intent to provide a Performance Guarantee
- T2.2-25 Foreign Exchange requirements (if applicable)



T2.2-26 Forecast Rate of Invoicing

T2.2-27 Three (3) years audited financial statements.

2.2 C1.1 Offer portion of Form of Offer & Acceptance

2.3 C1.2 Contract Data

2.4 C1.3 Forms of Securities

2.5 C2.1 Pricing Instructions (Activity Schedule)

2.6 C2.2 Activity Schedule



T2.2-01: Evaluation Schedule – Quality Management

The tenderer is to note that if awarded the contract, shall execute and complete the contract as per the Quality Management Standard, QAL-STD-0001 General Quality Requirements for Contractors and Suppliers and as per the TPT specification, Quality Management EEAM-Q-009.

The tenderer shall as a minimum submit the following:

- Project specific **Project Quality Management Plan** which satisfies the technical and quality requirements of the *works*, identifying all procedures, reviews, audits, controls and records used to control and verify compliance with the Works Information. The Project Quality Management Plan must include as a minimum (1.Objectives, 2.Roles & responsibilities, 3.Standards, 4. Assurance & 5.Control)
- Project specific **Quality data book index**.
- **Index/List of procedures and method statements** to be used during the contract.
- **Quality Control Plans (QCPs)** to be included specific to the Works Information for the following:
 - Structural works
 - Mechanical works
 - Electrical works
 - Control & Instrumentation

These QCPs shall identify all inspections, tests and verification requirements to meet Contractual obligations, specifications, drawings and related details including testing, witnessing and hold points.

The QCPs must include as a minimum;

1. Activity/Requirement,
 2. Specifications,
 3. Acceptance criteria,
 4. Approval status &
 5. Controlling documents.
- A signed **Quality Policy** based on International Organisation for Standardisation (ISO 9001:2008). The policy must clearly articulate the companies Quality Management System objectives and the methodology of achieving the stated objectives of the System. The policy must display the five key policy requirements. These requirements include:
 1. Is appropriate to the purpose of the organisation,
 2. Includes a commitment to comply with requirements and continually improve the effectiveness of the quality management system,
 3. Provides a framework for establishing and reviewing quality objectives,
 4. Is communicated and understood within the organisation, and
 5. Is reviewed for continuing suitability.
 - An **Audit Schedule** for internal and external audits during the contract.



Attached submissions to this schedule:

.....

.....

.....

.....

.....

.....

.....

.....

.....

.....



The scoring of the Quality Management in terms of the abovementioned requirements will be as follows:

Formulae: Points = $Score/100 \times 22$

Weight 22% of Technical Evaluation Criteria	Project Quality Management Plan (4/22) Formula: $score/100 \times 4$	Quality data book index (1/22) Formula: $score/100 \times 1$	Index/List of procedures and method statements (10/22) Formula: $score/100 \times 10$	Quality Control Plans (3/22) Formula: $score/100 \times 3$	Quality Policy (3/22) Formula: $score/100 \times 3$	Audit Schedule (1/22) Formula: $score/100 \times 1$
score 0	A Project Quality Management Plan was not submitted.	No Quality Data book index submitted.	No list of procedures or method statement submitted.	No QCPs submitted.	No Quality Policy submitted.	No or incomplete audit schedule submitted.
score 20	Includes any one of 1.Objectives, 2.Roles & responsibilities, 3.Standards, 4. Assurance & 5.Control.	N/A	Method statement provided for any one of the following: a) Bucket Wheel b) Operator Cabin c) VFDs d) Luffing cylinder e) Boom & Incline Conveyor drive trains	N/A	The Quality Policy is provided, it is based on ISO 9001:2008 and any one of the five key policy requirements are displayed, and the policy is signed.	N/A
	Includes any two of 1.Objectives, 2.Roles & responsibilities,	N/A	Method statement provided for any	N/A	The Quality Policy is provided, it is based on ISO 9001:2008 and any two of the five key	N/A



Weight 22% of Technical Evaluation Criteria	Project Quality Management Plan (4/22) Formula: score/100*4	Quality data book index (1/22) Formula: score/100*1	Index/List of procedures and method statements (10/22) Formula: score/100*10	Quality Control Plans (3/22) Formula: score/100*3	Quality Policy (3/22) Formula: score/100*3	Audit Schedule (1/22) Formula: score/100*1
score 40	3.Standards, 4. Assurance & 5.Control.		two of the following: a) Bucket Wheel b) Operator Cabin c) VFDs d) Luffing cylinder e) Boom & Incline Conveyor drive trains		policy requirements are displayed, and the policy is signed.	
score 60	Includes any three of 1.Objectives, 2.Roles & responsibilities, 3.Standards, 4. Assurance & 5.Control.	N/A	Method statement provided for any three of the following: a) Bucket Wheel b) Operator Cabin c) VFDs d) Luffing cylinder e) Boom & Incline Conveyor drive trains	N/A	The Quality Policy is provided, it is based on ISO 9001:2008 and any three of the five key policy requirements are displayed, and the policy is signed.	N/A

Weight 22% of Technical Evaluation Criteria	Project Quality Management Plan (4/22) Formula: score/100*4	Quality data book index (1/22) Formula: score/100*1	Index/List of procedures and method statements (10/22) Formula: score/100*10	Quality Control Plans (3/22) Formula: score/100*3	Quality Policy (3/22) Formula: score/100*3	Audit Schedule (1/22) Formula: score/100*1
score 80	Includes any four of 1.Objectives, 2.Roles & responsibilities, 3.Standards, 4. Assurance & 5.Control.The Project Quality Management Plan shows a complete understanding of the project quality requirements.	N/A	Method statement provided for any four of the following: a) Bucket Wheel b) Operator Cabin c) VFDs d) Luffing cylinder e) Boom & Incline Conveyor drive trains	N/A	The Quality Policy is provided, it is based on ISO 9001:2008 and any four of the five key policy requirements are displayed, and the policy is signed.	N/A
score 100	Includes all of 1.Objectives, 2.Roles & responsibilities, 3.Standards, 4. Assurance & 5.Control.	The Data book index is submitted and covers all and more of the project quality requirements.	Method statement provided all of the following: a) Bucket Wheel b) Operator Cabin c) VFDs d) Luffing cylinder e) Boom & Incline Conveyor drive trains	QCPs are submitted and cover all and more of the project quality requirements of the project scope.	The Quality Policy is provided, it is based on ISO 9001:2008 and all of the five key policy requirements are displayed, and the policy is signed.	An Audit Schedule for internal and external audits submitted.

T2.2-02: Evaluation Schedule: Project Organogram, Management & CV's

1. Submit the following documents as a minimum with your tender document:

1.1. A comprehensive and detailed **organogram** that shows the reporting lines, position titles, and names of persons assigned who will be involved in the *works*, inclusive of the key staff/professionals, identified in the Contract Data Part two.

1.2. Detailed CV's to show that they have well qualified personnel and have the necessary skills required to carry out the services identified in the Scope of Works document by providing the following:

- The roles and responsibilities for the *works* of each resource should be clearly stated.
- Detailed experience in this specific construction activity and positions held, such as recent assignments inclusive of total duration with start and end dates that has a bearing on the scope of work.
- Provide contactable references to verify the stated roles, responsibilities and experiences stated in the CVs.
- The education, training (*inter alia* NEC3) and skills of the assigned staff in the specific sector, field, subject, etc. which is directly linked to the *works*.
- Valid certified copies of Qualifications (degrees, diplomas, grades) and membership of professional societies and relevant professional registrations to be attached as proof.

2. The following table is to be populated by the tenderer identifying the resources for the key roles for the *works*. Attached submissions to this returnable.

Key Person Role	Name/s of Resource/s
Project Manager	
Construction Manager	

Health & Safety Officers x 3 (To ensure support 24/7)	
Quality Manager	
Schedule Manager/Planner	
Commissioning Manager	
Administration/Document Controller	

3. The scoring of the Project Organogram Management & CV's will be as follows:

Formulae: Total Points = $Score/100 \times 28$

3.1. For the Organogram

Formulae: Points = $Score/100 \times 2$

Weight 2% of Technical Evaluation Criteria	Organogram
score 0	No organogram submitted
score 20	N.A.
score 40	The organogram shows any one of the following: reporting lines, position titles or names of all persons identified in the Contract Data Part two.
score 60	N.A.
score 80	The organogram shows any two of the following: reporting lines, position titles and/or names of all persons identified in the Contract Data Part two.
score 100	The organogram shows any three of the following: reporting lines, position titles or names of all persons identified in the Contract Data Part two.

3.2. The Weight of the combined CV's is 26% of the Technical Evaluation Criteria limited to the following resources as indicated below:

- Project Manager (weight 7%)
- Construction Manager (weight 5%)
- Health and Safety Officers (weight 3%)
- Quality Manager (weight 4%)
- Schedule Manager/Planner (weight 2%)
- Commissioning Manager (weight 4%)
- Administration/Document Controller (weight 1%)

Each resource will be evaluated as follows based on the respective CV:

3.2.1. Project Manager (weight 7%)

Formulae: Points = $Score/100 \times 7$

Weight 7% of Technical Evaluation Criteria	Qualifications and detailed experience from the submitted CV
score 0	SACPCMP – Not registered as a Professional Construction/Project Manager and/or The Tenderer has submitted no information or inadequate information to determine a score, or the resource has ≤ 5 years or no relevant experience
score 20	SACPCMP – Registered as a Professional Construction / Project Manager and The resource has more than 5 years but ≤ 8 years relevant experience
score 40	SACPCMP – Registered as a Professional Construction / Project Manager and The resource has more than 8 years but ≤ 10 years relevant experience
score 60	SACPCMP – Registered as a Professional Construction / Project Manager and The resource has more than 10 years but ≤ 12 years relevant experience
score 80	SACPCMP – Registered as a Professional Construction / Project Manager

Weight 7% of Technical Evaluation Criteria	Qualifications and detailed experience from the submitted CV
	and The resource has more than 12 years but <= 15 years relevant experience
score 100	SACPCMP – Registered as a Professional Construction / Project Manager and The resource has more than 15 years relevant experience

3.2.2. Construction Manager (weight 5%)

Formulae: Points = $Score/100 \times 5$

Weight 5% of Technical Evaluation Criteria	Qualifications and detailed experience from the submitted CV
score 0	SACPCMP – Not registered as a Professional Construction Manager and / or The Tenderer has submitted no information or inadequate information to determine a score, or the resource has <= 5 years or no relevant experience
score 20	SACPCMP – Registered as a Professional Construction Manager and The resource has more than 5 years but <= 8 years relevant experience
score 40	SACPCMP – Registered as a Professional Construction Manager and The resource has more than 8 years but <= 10 years relevant experience
score 60	SACPCMP – Registered as a Professional Construction Manager and The resource has more than 10 years but <= 12 years relevant experience
score 80	SACPCMP – Registered as a Professional Construction Manager and

Weight 5% of Technical Evaluation Criteria	Qualifications and detailed experience from the submitted CV
	The resource has more than 12 years but <= 15 years relevant experience
score 100	SACPCMP – Registered as a Professional Construction Manager and The resource has more than 15 years relevant experience

3.2.3. Health and Safety Officers (weight 3%)

Formulae: Points = $Score/100 \times 3$

Weight 3% of Technical Evaluation Criteria	Qualifications and detailed experience from the submitted CV
score 0	SACPCMP – None of the resources are registered as a Health and Safety Officer and / or The Tenderer has submitted no information or inadequate information to determine a score and/or One or more of the three resources have <= 2 years' experience or no relevant experience
score 20	SACPCMP – All three resources are registered as a Health and Safety Officers and Each of the three resources has more than 2 years but <= 4 years relevant experience
score 40	SACPCMP – All three resources are registered as a Health and Safety Officers and Each of the three resources has more than 4 years but <= 6 years relevant experience
score 60	SACPCMP – All three resources are registered as a Health and Safety Officers and Each of the three resources has more than 6 years but <= 8 years relevant experience

Weight 3% of Technical Evaluation Criteria	Qualifications and detailed experience from the submitted CV
score 80	SACPCMP – All three resources are registered as a Health and Safety Officers and Each of the three resources has more than 8 years but <= 10 years relevant experience
score 100	SACPCMP – All three resources are registered as a Health and Safety Officers and Each of the three resources has more than 10 years relevant experience

3.2.4. Quality Manager (weight 4%)

Formulae: Points = $Score/100 \times 4$

Weight 4% of Technical Evaluation Criteria	Qualifications and detailed experience from the submitted CV
score 0	No relevant qualification and /or The Tenderer has submitted no information or inadequate information to determine a score, or the resource has <= 2 years or no relevant experience
score 20	BTech Quality Management, equivalent or higher qualification in quality management and The resource has more than 2 years but <= 4 years relevant experience
score 40	BTech Quality Management, equivalent or higher qualification in quality management and The resource has more than 4 years but <= 6 years relevant experience
score 60	BTech Quality Management, equivalent or higher qualification in quality management and The resource has more than 6 years but <= 8 years relevant experience

Weight 4% of Technical Evaluation Criteria	Qualifications and detailed experience from the submitted CV
score 80	BTech Quality Management, equivalent or higher qualification in quality management and The resource has more than 8 years but <= 10 years relevant experience
score 100	BTech Quality Management, equivalent or higher qualification in quality management and The resource has more than 10 years relevant experience

3.2.5. Schedule Manager/Planner (weight 2%)

Formulae: Points = $Score/100 \times 2$

Weight 2% of Technical Evaluation Criteria	Detailed experience of the resource from the submitted CV
score 0	The Tenderer has submitted no information or inadequate information to determine a score, or the resource has <= 2 years or no relevant experience
score 20	The resource has more than 2 years but <= 4 years relevant experience
score 40	The resource has more than 4 years but <= 6 years relevant experience
score 60	The resource has more than 6 years but <= 8 years relevant experience
score 80	The resource has more than 8 years but <= 10 years relevant experience
score 100	The resource has more than 10 years relevant experience

3.2.6. Commissioning Manager (weight 4%)

Formulae: Points = $Score/100 \times 4$

Weight 4% of Technical Evaluation Criteria	Qualifications and detailed experience from the submitted CV
score 0	No qualification and /or The Tenderer has submitted no information or inadequate information to determine a score, or the resource has ≤ 5 years or no relevant experience
score 20	A relevant valid technical qualification (mechanical, structural, electrical and/or control & instrumentation) above NQF level 4 and The resource has more than 5 years but ≤ 8 years relevant experience
score 40	A relevant valid technical qualification (mechanical, structural, electrical and/or control & instrumentation) above NQF level 4 and The resource has more than 8 years but ≤ 10 years relevant experience
score 60	A relevant valid technical qualification (mechanical, structural, electrical and/or control & instrumentation) above NQF level 4 and The resource has more than 10 years but ≤ 12 years relevant experience
score 80	A relevant valid technical qualification (mechanical, structural, electrical and/or control & instrumentation) above NQF level 4 and The resource has more than 12 years but ≤ 15 years relevant experience
score 100	A relevant valid technical qualification (mechanical, structural, electrical and/or control & instrumentation) above NQF level 4 and The resource has more than 15 years relevant experience

3.2.7. Administration/Document Controller (weight 1%)

Formulae: Points = $Score/100 \times 1$

Weight 1% of Technical Evaluation Criteria	Detailed experience of the resource from the submitted CV
score 0	The Tenderer has submitted no information or inadequate information to determine a score, or the resource has ≤ 2 years or no relevant experience
score 20	The resource has > 2 years but ≤ 4 years relevant experience
score 40	The resource has > 4 years but ≤ 6 years relevant experience
score 60	The resource has > 6 years but ≤ 8 years relevant experience
score 80	The resource has > 8 years but ≤ 10 years relevant experience
score 100	The resource has > 10 years relevant experience



T2.2-03: Availability of Equipment and Other Resources

- In the table below the Tenderer to submit a list of all equipment and other resources that are required to execute the *works* and that will be provided and used to execute the required *works* as described in the Works Information. The following equipment must be available as a minimum for the execution of the *works* by completing the table below: Low bed Truck, Scaffolding, Cranes 120t & 90t, Cherrypicker and Generator.
- The Tenderer must confirm that the Low bed Truck, Scaffolding, Cranes 120t & 90t, Cherrypicker and Generator will be available for the execution of the *works* by submitting the following evidence with the tender:
 - In case where the Contractor owns the equipment, evidence of ownership such as copies of vehicle license discs must be submitted with the tender, or
 - In case of lease/rental, copies of agreements between the Tenderer and supplier that confirms the intent to lease/rent the equipment for the execution period once a contract has been signed between Transnet and the Contractor.

Table 1: Confirmed List of Equipment that will be provided

Equipment Type and Availability – Description	Hourly Rate	Number of Equipment	Details of Ownership or Intent of Lease/Rent attached. State Yes or No



Weight 5% of Technical Evaluation Criteria	Availability of Equipment and Other Resources (5/5) Formula: score/100x5
score 0	Less than two of the following confirmed to be available in the Table 1 above: Low bed Truck, Scaffolding, Cranes 120t & 90t, Cherrypicker and Generator
score 20	Two of the following confirmed to be available in the Table 1 above: Low bed Truck, Scaffolding, Cranes 120t & 90t, Cherrypicker and Generator
score 40	Three of the following confirmed to be available in the Table 1 above: Low bed Truck, Scaffolding, Cranes 120t & 90t, Cherrypicker and Generator
score 60	Four of the following confirmed to be available in the Table 1 above: Low bed Truck, Scaffolding, Cranes 120t & 90t, Cherrypicker and Generator
score 80	Five of the following confirmed to be available in the Table 1 above: Low bed Truck, Scaffolding, Cranes 120t & 90t, Cherrypicker and Generator
score 100	All of the following confirmed to be available in the Table 1 above: Low bed Truck, Scaffolding, Cranes 120t & 90t, Cherrypicker and Generator

T2.2-04: Evaluation Schedule: Programme

Notes to tenderers:

The Tenderer details the programme for evaluation and attaches a hard copy to this returnable schedule. In addition, the Tenderer is to provide a Microsoft Project 2016 electronic copy of the programme.

For Evaluation Purposes, the Programme is to be submitted in the following manner:

- Only Microsoft Project 2016 format will be accepted.
- A PDF copy of the Programme is to be attached to this returnable schedule.
- A soft copy of the proposed programme in Microsoft Project 2016 is to be submitted on or before the tender closing date via a OneDrive link which will be made available to all Tenderers who submitted a tender.
- Failure to submit a soft copy of the proposed programme in Microsoft project 2016 compatible format will result in the Tenderer's programme not being evaluated and the tenderer will score zero (0) out of twenty (20) for programme.

The Tenderer's attention is drawn to core clause 31 of the NEC3 Engineering and Construction contract regarding the items to be shown on a programme.

The tenderer shall provide the proposed programme, at a minimum **Level 2/3** showing but not limited to the following:

- Ability to execute the works in terms of the *Employer's* requirements and within the required timeframe indicating, in a logical sequence, the order and timing of the construction that will take place to Provide the Works clearly indicating the capacity & capability to achieve the dates stated in the Contract Data.
- Dates when the *Contractor* will need access to any part of the Site; submission & approval process & timing for Health & Safety Files, Environmental Files and Quality Files. In addition, the Programme must clearly demonstrate the procurement process for all long lead items if applicable.
- The *Contractor* indicates how he plans in achieving the following dates and clearly demonstrates them on the schedule - Start Date, Access Date, Planned Completion, Key Dates/Sectional Completion Dates & Completion Date. In addition, the Programme clearly demonstrates adequate provisions for Time Risk Allowance (TRA). Time Risk Allowances are not float, are owned by the Tenderer, can be included in the activity duration and illustrated in the schedule in a code field or as an attachment.

The scoring of the Programme will be as follows:

Formula: score/100x20

	Score		
Weight 20% of Technical Evaluation Criteria	Ability to execute the works in terms of the Employer's requirements 6/20	Indicated the order and timing of all activities that will take place in order to provide the works in the shortest possible duration. 13/20	At a minimum a Level 2 Programme is developed electronically and submitted in hard and soft copy, in Microsoft Project 2016 format, with the Tender. 1/20
Score 0	A soft copy of the programme in Microsoft Project 2016 was not submitted.	The soft copy of the programme in Microsoft Project 2016 was not submitted. Or The tenderer requires more than 5 weeks in total during the 2024 shut period to provide the works.	A programme in Microsoft Project 2016 format was not submitted in hardcopy and softcopy.
Score 20	N/A	N/A	N/A
Score 40	N/A	N/A	A level 1 programme in Microsoft Project 2016 format was submitted on hardcopy and softcopy.
Score 60	A soft copy of the programme in Microsoft Project 2016 was submitted And The programme lists all the activities required to execute all of the scope of Section 4.3.7 of the Scope of Works to a Level 1 level of detail.	N/A	A level 2 programme was submitted in Microsoft Project 2016 format on hardcopy and softcopy but does not include and cover all the following: <ul style="list-style-type: none"> - Dates when the Contractor will need access to any part of the Site and for submission & approval process & timing for Health & Safety Files, Environmental Files and Quality Files. - The Programme must clearly demonstrate the procurement process and dates (start to delivery) for all items to be provided in terms of the scope of works. Refer Section 4.3.7 of the Scope of Works. - Start Date, Access Date, Planned Completion, Key Dates/Sectional Completion Dates & Completion Dates for each scope item. Refer Section 4.3.7 of the Scope of Works.
Score 80	A soft copy of the programme in Microsoft Project 2016 was submitted And	A soft copy of the programme in Microsoft Project 2016 was submitted And	N/A

DESCRIPTION OF THE WORKS: THE SUPPLY OF SERVICES TO REFURBISH STACKER RECLAIMER 3 AT THE SALDANHA IRON ORE TERMINAL FORTRANSNET SOC LTD (REG.NO.1990/000900/30) OPERATING AS TRANSNET PORT TERMINALS, (HEREINAFTER REFERRED TO AS "TPT"), AS A ONCE OFF SUPPLY.

	Score		
Weight 20% of Technical Evaluation Criteria	Ability to execute the works in terms of the Employer's requirements 6/20	Indicated the order and timing of all activities that will take place in order to provide the works in the shortest possible duration. 13/20	At a minimum a Level 2 Programme is developed electronically and submitted in hard and soft copy, in Microsoft Project 2016 format, with the Tender. 1/20
	The programme lists all of the activities required as per Section 4.3.7 to a Level 2 level of detail.	The tenderer requires 5 weeks during the 2024 shut period to provide the works.	
Score 100	<p>A soft copy of the programme in Microsoft Project 2016 was submitted</p> <p>And</p> <p>The programme lists all of the activities required in the Scope of Works to a level of detail that clearly shows that the Contractor understands the full scope and has catered for it in the programme. This includes all other activities in addition to the execution activities related to the Activity schedule.</p>	<p>A soft copy of the programme in Microsoft Project 2016 was submitted</p> <p>And</p> <p>The tenderer requires < 5 weeks during the 2024 shut period to provide the works.</p>	<p>A level 2 programme in Microsoft Project 2016 format was submitted on hardcopy and softcopy that includes and covers all the following:</p> <ul style="list-style-type: none"> - Dates when the <i>Contractor</i> will need access to any part of the Site and for submission & approval process & timing for Health & Safety Files, Environmental Files and Quality Files. - The Programme must clearly demonstrate the procurement process and dates (start to delivery) for all items to be provided in terms of the scope of works. Refer Section 4.3.7 of the Scope of Works. - Start Date, Access Date, Planned Completion, Key Dates/Sectional Completion Dates & Completion Dates for each scope item. Refer Section 4.3.7 of the Scope of Works.

Attachment A: Electronic Copy of Programme

Attachment B: Hard Copy of Programme

T2.2-05: Evaluation Schedule: Previous Experience

Note to tenderers:

Tenderers are required to demonstrate performance in comparable projects of similar size and nature by supplying the following:

- Supporting information with sufficient references ((Client name and contact details, project description, duration, contract value & year actioned) to substantiate that the tenderer has substantive experience of refurbishment projects of similar works specific to bulk material handling Stackers/Reclaimers within the last 10 years.
- The supporting information must be supported with evidence such as Appointment Letters and/or Completion Certificates and/or Purchase Orders and/or Contracts that shows when the experience was gained, high level scope and value.

Index of documentation attached to this schedule

	DOCUMENT NAME
1	
2	
3	
4	
5	
6	
7	

The scoring will be as follows:

Formula: $\text{score}/100 \times 25$

	Score
Weight 25% of Technical Evaluation Criteria	Previous Experience
Score 0	The tenderer has no substantive experience of a successful refurbishment project of similar works specific to bulk material handling Stackers/Reclaimers within the last 10 years.
Score 20	The tenderer has substantive experience of at least one (1) successful refurbishment project of similar works specific to bulk material handling Stackers/Reclaimers with an individual project value of at least R20m within the last 10 years.
Score 40	The tenderer has substantive experience of refurbishment projects of similar works specific to bulk material handling Stackers/Reclaimers within the last 10 years as follows: one or two projects totaling minimum R40m.
Score 60	The tenderer has substantive experience of refurbishment projects of similar works specific to bulk material handling Stackers/Reclaimers within the last 10 years as follows: one, two or three projects totaling minimum R60m.
Score 80	The tenderer has substantive experience of refurbishment projects of similar works specific to bulk material handling Stackers/Reclaimers within the last 10 years as follows: one, two, three or four projects totaling minimum R80m.
Score 100	The tenderer has substantive experience of refurbishment projects of similar works specific to bulk material handling Stackers/Reclaimers within the last 10 years as follows: one, two, three, four or five projects totaling minimum R100m.



T2.2-06: Authority to submit a Tender

Indicate the status of the tenderer by ticking the appropriate box hereunder. The tenderer must complete the certificate set out below for his category of organisation or alternatively attach a certified copy of a company / organisation document which provides the same information for the relevant category as requested here.

A - COMPANY	B - PARTNERSHIP	C - JOINT VENTURE	D - SOLE PROPRIETOR

A. Certificate for Company

I, _____ chairperson of the board of directors _____
 _____, hereby confirm that by resolution of the
 board taken on _____ (date), Mr/Ms _____,
 acting in the capacity of _____, was authorised to sign all
 documents in connection with this tender offer and any contract resulting from it on behalf of
 the company.

Signed

Date

Name

Position

Chairman of the Board of Directors



B. Certificate for Partnership

We, the undersigned, being the **key partners** in the business trading as _____

_____ hereby authorise Mr/Ms _____

acting in the capacity of _____, to sign all documents in

connection with the tender offer for Contract _____ and any

contract resulting from it on our behalf.

Name	Address	Signature	Date

NOTE: This certificate is to be completed and signed by the full number of Partners necessary to commit the Partnership. Attach additional pages if more space is required.



C. Certificate for Joint Venture

We, the undersigned, are submitting this tender offer in Joint Venture and hereby authorise Mr/Ms _____, an authorised signatory of the company _____, acting in the capacity of lead partner, to sign all documents in connection with the tender offer for Contract _____ and any contract resulting from it on our behalf.

This authorisation is evidenced by the attached power of attorney signed by legally authorised signatories of all the partners to the Joint Venture.

Furthermore we attach to this Schedule a copy of the joint venture agreement which incorporates a statement that all partners are liable jointly and severally for the execution of the contract and that the lead partner is authorised to incur liabilities, receive instructions and payments and be responsible for the entire execution of the contract for and on behalf of any and all the partners.

Name of firm	Address	Authorising signature, name (in caps) and capacity



D. Certificate for Sole Proprietor

I, _____, hereby confirm that I am the sole owner of the business trading as _____.

Signed

Date

Name

Position

Sole Proprietor



T2.2-07: Record of Addenda to Tender Documents

This schedule as submitted confirms that the following communications received from the *Employer* before the submission of this tender offer, amending the tender documents, have been taken into account in this specific tender offer:

	Date	Title or Details
1		
2		
3		
4		
5		
6		
7		
8		
9		
10		
11		
12		
13		
14		
15		

TRANSNET PORT TERMINALS
TENDER NUMBER: TTPT/2024/03/0066/60631/RFP
DESCRIPTION OF THE SERVICES: FOR THE SUPPLY OF SERVICES TO REFURBISH STACKER RECLAIMER 3 AT THE SALDANHA IRON ORE TERMINAL FOR TRANSNET SOC LTD (REG.NO.1990/000900/30) OPERATING AS TRANSNET PORT TERMINALS, (HEREINAFTER REFERRED TO AS "TPT"), AS A ONCE OFF SUPPLY.



T2.2-09 Letter/s of Good Standing with the Workmen's Compensation Fund

Attached to this schedule is the Letter/s of Good Standing.

- 1.
- 2.
- 3.
- 4.

Name of Company/Members of Joint Venture:

.....
.....
.....
.....
.....
.....
.....
.....
.....
.....
.....



T2.2-09: Risk Elements

Tenderers to identify and evaluate the potential risk elements associated with the Works and possible mitigation thereof. The risk elements and the mitigation as identified thereof by the Tenderer are to be submitted.

If No Risks are identified "No Risks" must be stated on this schedule.

Tenderers are also to evaluate any risk/s stated by the Employer in Contract Data Part C1, and provide possible mitigation thereof.

Tenders to note: Notwithstanding this information, all costs related to risk elements which are at the Contractor's risk are deemed to be included in the tenderer's offered total of the Prices.

TRANSNET PORT TERMINALS

TENDER NUMBER: TPT/2024/03/0066/60631/RFP

DESCRIPTION OF THE SERVICES: FOR THE SUPPLY OF SERVICES TO REFURBISH STACKER RECLAIMER 3 AT THE SALDANHA IRON ORE TERMINAL FOR TRANSNET SOC LTD (REG.NO.1990/000900/30) OPERATING AS TRANSNET PORT TERMINALS, (HEREINAFTER REFERRED TO AS "TPT"), AS A ONCE OFF SUPPLY.





T2.2-11: Availability of Equipment and Other Resources

The Tenderer to submit a list of all Equipment and other resources that will be used to execute the *works* as described in the Works Information.

Equipment Type and Availability – Description	Hourly Rate	Number of Equipment	Details of Ownership



TRANSNET PORT TERMINALS

TENDER NUMBER: TPT/2024/03/0066/60631/RFP

DESCRIPTION OF THE SERVICES: FOR THE SUPPLY OF SERVICES TO REFURBISH STACKER RECLAIMER 3 AT THE SALDANHA IRON ORE TERMINAL FOR TRANSNET SOC LTD (REG.NO.1990/000900/30) OPERATING AS TRANSNET PORT TERMINALS, (HEREINAFTER REFERRED TO AS "TPT"), AS A ONCE OFF SUPPLY.

T2.2-10 Schedule: Sub-Contract:

Tenderers are required to Sub-contracting of **a minimum of 30%** to one or more company/ies that meets the requirements of the **TPPP as** indicated hereto:

- i. an EME or QSE which is at least 51% owned by black people;
- ii. an EME or QSE which is at least 51% owned by black people who are youth;
- iii. an EME or QSE which is at least 51% owned by black people who are women; or
- iv. an EME or QSE which is at least 51% owned by black people with disabilities;
- v. an EME or QSE which is 51% owned by black people living in rural or undeveloped areas or townships;
- vi. a cooperative which is at least 51% owned by black people;
- vii. an EME or QSE which is at least 51% owned by black people who are military veterans.

Tenderer to note that if successful, any deviations from the list of proposed sub-contractors in the contract phase will be subject to acceptance by the *Project Manager* in terms of the Conditions of Contract. Please also note the applicable Z clauses in Contract Data by *Employer*.

Provide **detailed information** of the proposed Sub-contractors below:

	Name of proposed Subcontractor	National Treasury CSD Number of sub-contractor	Address and Region	B-BBEEE Certificates or Sworn Affidavit attached to this schedule? Yes/No	Percentage (%) of the sub-contracted works in terms of the tendered total of the prices.
1.					
2.					
3.					



TRANSNET PORT TERMINALS

TENDER NUMBER: TPT/2024/03/0066/60631/RFP

DESCRIPTION OF THE SERVICES: FOR THE SUPPLY OF SERVICES TO REFURBISH STACKER RECLAIMER 3 AT THE SALDANHA IRON ORE TERMINAL FOR TRANSNET SOC LTD (REG.NO.1990/000900/30) OPERATING AS TRANSNET PORT TERMINALS, (HEREINAFTER REFERRED TO AS "TPT"), AS A ONCE OFF SUPPLY.

4.					
5.					
6.					
7.					
8.					
9.					
10.					

The Tenderer is to submit the following documents or copies thereof for each of the proposed sub- contractors(s) with this schedule:

- Valid B-BBEE Sworn Affidavits or B-BBEE Certificates of each of the proposed sub- contractors(s).

NOTE TO TENDERERS: FAILURE TO PROVIDE THE ABOVE DOCUMENTS WILL RESULT IN THE NOMINATED SUBCONTRACTOR'S PERCENTAGE BEING DISCOUNTED TO ZERO.

Transnet reserves the right to request additional information of the nominated sub-consultants should it be deemed necessary to verify the compliance to the black ownership percentage or sub- contractors entity size. These may include but not limited to;

- Agreement or Letter of Intent confirming the Sub-Contracting Agreement between the tenderer and proposed sub-contractors(s);
- Copies of the identity documents of the members of shareholders of the contractors;
- Copies of the Audited Financial Statements or Income Statement of the sub- contractors.

TRANSNET PORT TERMINALS

TENDER NUMBER: TPT/2024/03/0066/60631/RFP

DESCRIPTION OF THE SERVICES: FOR THE SUPPLY OF SERVICES TO REFURBISH STACKER RECLAIMER 3 AT THE SALDANHA IRON ORE TERMINAL FOR TRANSNET SOC LTD (REG.NO.1990/000900/30) OPERATING AS TRANSNET PORT TERMINALS, (HEREINAFTER REFERRED TO AS "TPT"), AS A ONCE OFF SUPPLY

SBD 6.2

T2.2-11: Schedule: Declaration of Certificate for Local Production and Content for Designated Sectors

This Standard Bidding Document (SBD) must form part of all bids invited. It contains general information and serves as a declaration form for local content (local production and local content are used interchangeably).

Before completing this declaration, bidders must study the General Conditions, Definitions, Directives applicable in respect of Local Content as prescribed in the Preferential Procurement Regulations, the South African Bureau of Standards (SABS) approved technical specification number SATS 1286:2011 (Edition 1) and the Guidance on the Calculation of Local Content together with the Local Content Declaration Templates [Annex C (Local Content Declaration: Summary Schedule),

1. General Conditions

- 1.1. Preferential Procurement Regulations, makes provision for the promotion of local production and content.
- 1.2. Regulation 8.(1) prescribes that in the case of designated sectors, where in the award of bids local production and content is of critical importance, such bids must be advertised with the specific bidding condition that only locally produced goods, services or works or locally manufactured goods, with a stipulated minimum threshold for local production and content will be considered.
- 1.3. Where necessary, for bids referred to in paragraph 1.2 above, a two stage bidding process may be followed, where the first stage involves a minimum threshold for local production and content and the second stage price and B-BBEE.
- 1.4. A person awarded a contract in relation to a designated sector, may not sub-contract in such a manner that the local production and content of the overall value of the contract is reduced to below the stipulated minimum threshold.
- 1.5. The local content (LC) expressed as a percentage of the bid price must be calculated in accordance with the SABS approved technical specification number SATS 1286: 2011 as follows:

$$LC = [1 - x / y] * 100$$

Where

x is the imported content in Rand

y is the bid price in Rand excluding value added tax (VAT)

Prices referred to in the determination of x must be converted to Rand (ZAR) by using the exchange rate published by South African Reserve Bank (SARB) at 12:00 on the date of advertisement of the bid as indicated in paragraph 4.1 below.

The SABS approved technical specification number SATS 1286:2011 is accessible on <http://www.thedti.gov.za/industrial-development/ip.jsp> at no cost.

- 1.6. A bid may be disqualified if this Declaration Certificate and the Annex C (Local Content Declaration: Summary Schedule) are not submitted as part of the bid documentation;

2. Definitions



TRANSNET PORT TERMINALS

TENDER NUMBER: TPT/2024/03/0066/60631/RFP

DESCRIPTION OF THE SERVICES: FOR THE SUPPLY OF SERVICES TO REFURBISH STACKER RECLAIMER 3 AT THE SALDANHA IRON ORE TERMINAL FOR TRANSNET SOC LTD (REG.NO.1990/000900/30) OPERATING AS TRANSNET PORT TERMINALS, (HEREINAFTER REFERRED TO AS "TPT"), AS A ONCE OFF SUPPLY

- 2.1. **"bid"** includes written price quotations, advertised competitive bids or proposals;
 - 2.2. **"bid price"** price offered by the bidder, excluding value added tax (VAT);
 - 2.3. **"contract"** means the agreement that results from the acceptance of a bid by an organ of state;
 - 2.4. **"designated sector"** means a sector, sub-sector or industry that has been designated by the Department of Trade and Industry in line with national development and industrial policies for local production, where only locally produced services, works or goods or locally manufactured goods meet the stipulated minimum threshold for local production and content;
 - 2.5. **"duly sign"** means a Declaration Certificate for Local Content that has been signed by the Chief Financial Officer or other legally responsible person nominated in writing by the Chief Executive, or senior member / person with management responsibility(close corporation, partnership or individual).
 - 2.6. **"imported content"** means that portion of the bid price represented by the cost of components, parts or materials which have been or are still to be imported (whether by the supplier or its subcontractors) and which costs are inclusive of the costs abroad (this includes labour or intellectual property costs), plus freight and other direct importation costs, such as landing costs, dock duties, import duty, sales duty or other similar tax or duty at the South African port of entry;
 - 2.7. **"local content"** means that portion of the bid price which is not included in the imported content, provided that local manufacture does take place;
 - 2.8. **"stipulated minimum threshold"** means that portion of local production and content as determined by the Department of Trade and Industry; and
 - 2.9. **"sub-contract"** means the primary contractor's assigning, leasing, making out work to, or employing another person to support such primary contractor in the execution of part of a project in terms of the contract.
3. **The stipulated minimum threshold(s) for local production and content (refer to Annex A of SATS 1286:2011) for this bid is/are as follows:**

<u>Description of services, works or goods</u>	<u>Stipulated minimum threshold</u>
• Steel Products and Components for Construction	100%
• Electrical Cables;	90%
• Bogie	100%
• Medium Voltage Electric Motors	100%
• Pulleys	60%

4. Does any portion of the services, works or goods offered have any imported content?

(Tick applicable box)

YES	<input type="checkbox"/>	NO	<input type="checkbox"/>
-----	--------------------------	----	--------------------------



TRANSNET PORT TERMINALS

TENDER NUMBER: TPT/2024/03/0066/60631/RFP

DESCRIPTION OF THE SERVICES: FOR THE SUPPLY OF SERVICES TO REFURBISH STACKER RECLAIMER 3 AT THE SALDANHA IRON ORE TERMINAL FOR TRANSNET SOC LTD (REG.NO.1990/000900/30) OPERATING AS TRANSNET PORT TERMINALS, (HEREINAFTER REFERRED TO AS "TPT"), AS A ONCE OFF SUPPLY

- 4.1. If yes, the rate(s) of exchange to be used in this bid to calculate the local content as prescribed in paragraph 1.5 of the general conditions must be the rate(s) published by SARB for the specific currency at 12:00 on the date of advertisement of the bid.

The relevant rates of exchange information is accessible on www.reservebank.co.za

Indicate the rate(s) of exchange against the appropriate currency in the table below (refer to Annex A of SATS 1286:2011):

Currency	Rates of exchange
US Dollar	
Pound Sterling	
Euro	
Yen	
Other	

NB: Bidders must submit proof of the SARB rate (s) of exchange used.

5. Where, after the award of a bid, challenges are experienced in meeting the stipulated minimum threshold for local content the dti must be informed accordingly in order for the dti to verify and in consultation with the AO/AA provide directives in this regard.



TRANSNET PORT TERMINALS

TENDER NUMBER: TPT/2024/03/0066/60631/RFP

DESCRIPTION OF THE SERVICES: FOR THE SUPPLY OF SERVICES TO REFURBISH STACKER RECLAIMER 3 AT THE SALDANHA IRON ORE TERMINAL FOR TRANSNET SOC LTD (REG.NO.1990/000900/30) OPERATING AS TRANSNET PORT TERMINALS, (HEREINAFTER REFERRED TO AS "TPT"), AS A ONCE OFF SUPPLY

LOCAL CONTENT DECLARATION
(REFER TO ANNEX B OF SATS 1286:2011)

LOCAL CONTENT DECLARATION BY CHIEF FINANCIAL OFFICER OR OTHER LEGALLY RESPONSIBLE PERSON NOMINATED IN WRITING BY THE CHIEF EXECUTIVE OR SENIOR MEMBER/PERSON WITH MANAGEMENT RESPONSIBILITY (CLOSE CORPORATION, PARTNERSHIP OR INDIVIDUAL)

IN RESPECT OF BID NO. TPT/2023/06/0010/31834/RFP

ISSUED BY: TRANSNET PORT TERMINALS ON BEHALF OF TRANSNET SOC LTD

NB

- 1 The obligation to complete, duly sign and submit this declaration cannot be transferred to an external authorized representative, auditor or any other third party acting on behalf of the bidder.
- 2 Guidance on the Calculation of Local Content together with Local Content Declaration Templates (Annex C, D and E) is accessible on http://www.thdti.gov.za/industrial_development/ip.jsp. Bidders should first complete Declaration D. After completing Declaration D, bidders should complete Declaration E and then consolidate the information on Declaration C. **Declaration C should be submitted with the bid documentation at the closing date and time of the bid in order to substantiate the declaration made in paragraph (c) below.** Declarations D and E should be kept by the bidders for verification purposes for a period of at least 5 years. The successful bidder is required to continuously update Declarations C, D and E with the actual values for the duration of the contract.

I, the undersigned, (full names), do hereby declare, in my capacity asof.....(name of bidder entity), the following:

- (a) The facts contained herein are within my own personal knowledge.
- (b) I have satisfied myself that:
 - (i) the goods/services/works to be delivered in terms of the above-specified bid comply with the minimum local content requirements as specified in the bid, and as measured in terms of SATS 1286:2011; and
- (c) The local content percentage (%) indicated below has been calculated using the formula given in clause 3 of SATS 1286:2011, the rates of exchange indicated in paragraph 4.1 above and the information contained in Declaration D and E which has been consolidated in Declaration C:

Price of the Designated commodity Steel Products and Components for Construction Ex VAT	R
Imported content (x), as calculated in terms of SATS 1286:2011	R
Stipulated minimum threshold for local content (paragraph 3 above)	
Local content %, as calculated in terms of SATS 1286:2011	

Price of the Designated commodity Electrical Cables; Ex Vat	R
Imported content (x), as calculated in terms of SATS 1286:2011	R
Stipulated minimum threshold for local content (paragraph 3 above)	

TRANSNET PORT TERMINALS

TENDER NUMBER: TPT/2024/03/0066/60631/RFP

DESCRIPTION OF THE SERVICES: FOR THE SUPPLY OF SERVICES TO REFURBISH STACKER RECLAIMER 3 AT THE SALDANHA IRON ORE TERMINAL FOR TRANSNET SOC LTD (REG.NO.1990/000900/30) OPERATING AS TRANSNET PORT TERMINALS, (HEREINAFTER REFERRED TO AS "TPT"), AS A ONCE OFF SUPPLY

Local content %, as calculated in terms of SATS 1286:2011	
Price of the Designated commodity Bogie . Ex Vat	R
Imported content (x), as calculated in terms of SATS 1286:2011	R
Stipulated minimum threshold for local content (paragraph 3 above)	
Local content %, as calculated in terms of SATS 1286:2011	
Price of the Designated commodity Medium Voltage Electric Motors Ex Vat	R
Imported content (x), as calculated in terms of SATS 1286:2011	R
Stipulated minimum threshold for local content (paragraph 3 above)	
Local content %, as calculated in terms of SATS 1286:2011	
Price of the Designated commodity Pulleys Ex Vat	R
Imported content (x), as calculated in terms of SATS 1286:2011	R
Stipulated minimum threshold for local content (paragraph 3 above)	
Local content %, as calculated in terms of SATS 1286:2011	

If the bid is for more than one product, the local content percentages for each product contained in Declaration C shall be used instead of the table above. The local content percentages for each product has been calculated using the formula given in clause 3 of SATS 1286:2011, the rates of exchange indicated in paragraph 4.1 above and the information contained in Declaration D and E.

(d) I accept that the Procurement Authority / Institution has the right to request that the local content be verified in terms of the requirements of SATS 1286:2011.

(e) I understand that the awarding of the bid is dependent on the accuracy of the information furnished in this application. I also understand that the submission of incorrect data, or data that are not verifiable as described in SATS 1286:2011, may result in the Procurement Authority / Institution imposing any or all of the remedies.

SIGNATURE: _____ **DATE:** _____

WITNESS No. 1 _____ **DATE:** _____

WITNESS No. 2 _____ **DATE:** _____

NOTE TO TENDERERS: Failure to fully complete, declare, sign & date this SBD6.2 Declaration as well as the accompanying Annexure C "local content declaration - summary schedule" may result in the tender submission being non-responsive and disqualified from any further evaluation.

Schedule A – Non-compliance for Local Content

Non-compliance Penalties for Local Content:

- a) If for any reason the *Contractor* is unable to achieve the local content undertaking, the *Contractor* must approach the Department of Trade and Industry ("DTI") to obtain exemption in order to supply the goods at a lower local content threshold. The *Contractor* is obliged to approach DTI for exemption within 10 (ten) days of determining that it is unable to achieve any milestone target or local content threshold.
- b) Should the DTI provide exemption, the *Contractor* shall be entitled to provide the goods at the lower local content threshold set by DTI. In such event, the Parties shall in good faith renegotiate the milestone targets or local content undertaking to ensure that the lowered local content thresholds are achieved.
- c) Should DTI not provide the necessary exemption, the *Contractor* shall be obliged to meet each milestone target as stated in the Local Content Plan or the local content undertaking.
- d) Should the *Contractor* fail to meet any milestone target or the local content undertaking, the following remedies shall apply without limiting any of the *Employer's* other rights in law:
 - i. The *Employer* shall afford the *Contractor* a period of thirty (30) days to remedy its non-compliance.
 - ii. Should the *Contractor* fail to meet its obligations within the further 30 day period, the *Contractor* shall pay a Non-Compliance penalty ("Non-compliance Penalty") to the *Employer* in respect of such Non-compliance as set out in clause iv below. The penalties shall be imposed per milestone measurement for non-delivery of committed values in the case of a Local Content Plan or shall be imposed against the non-delivery of committed values where local content undertakings must be met immediately.
 - iii. To the extent that the Actual Local Content Spend¹ is lower than the Required Local Content Spend² (or the Adjusted Required Local Content Spend³, as the case may be), the *Contractor* shall be liable for Penalties which is the difference in value between the Actual Local Content Spend and the Required Local Content Spend (or the Adjusted Required Local Content Spend, as the case may be) plus an additional percentage of such difference. Such Non-compliance Penalties shall be calculated and levied at the relevant milestones as stipulated in the Local Content Plan or shall be imposed against the non-delivery of committed values where local content undertakings must be met immediately, in accordance with clause iv below.
 - iv. Non-compliance penalties shall apply at the following rate: the difference in value between the Required Local Content Spend and the Actual Local Content Spend, plus 5% of such difference.
 - v. In order to guarantee that the *Contractor* meets its obligations in terms of the Local Content Plan or its committed local content undertaking, the *Employer* shall be entitled to retain a Non-compliance Penalty at the rate of 1% of every monthly payment due by the *Employer* to the *Contractor* over the contract period ("the Local Content Retention Amount"). The Local Content Retention Amount shall be set off against any penalties payable by the *Contractor* at any milestone assessment.

¹ Actual Local Content Spend means the monetary value of local content initiatives actually delivered by the Supplier during the period under review.

² Required Local Content Spend means the monetary value of local content obligations that the Supplier has agreed to deliver during the period under review.

³ Adjusted Required Local Content Spend means any adjustment to the Required Local Content Spend as prescribed by DTI through the process of exemption referred to in clause c) above and as agreed to between the parties, reduced to writing and signed by the parties.

TRANSNET PORT TERMINALS

TENDER NUMBER: TPT/2024/03/0066/60631/RFP

DESCRIPTION OF THE SERVICES: FOR THE SUPPLY OF SERVICES TO REFURBISH STACKER RECLAIMER 3 AT THE SALDANHA IRON ORE TERMINAL FOR TRANSNET SOC LTD (REG.NO.1990/000900/30) OPERATING AS TRANSNET PORT TERMINALS, (HEREINAFTER REFERRED TO AS "TPT"), AS A ONCE OFF SUPPLY

- e) Should no penalties be imposed during the duration of the contract, the *Employer* shall refund the full value of the Local Content Retention Amount to the *Contractor* at the end of the contract period.
- f) Should any unpaid penalties remain at the end of the contract period, then without limiting other rights that the *Employer* may have in law, the *Contractor* shall forfeit the Local Content Retention Amount and shall have no further claim against the *Employer* for the repayment of such amount.

Non-compliance Penalty Certificate:

- a) If any Non-compliance Penalty arises, the *Employer* shall issue a Non-compliance Penalty Certificate on the last day of each month during such Non-compliance indicating the Non-compliance Penalties which have accrued during that period.
- b) A Non-compliance Penalty Certificate shall be prima facie proof of the matters to which it relates. If the *Contractor* disputes any of the amounts set out in a Non-compliance Penalty Certificate:
 - the dispute shall be resolved in accordance with the provisions of the Contract; and
 - if pursuant to that referral, it is determined that the *Contractor* owes any amount to the *Employer* pursuant to the Non-compliance Penalty Certificate, then the *Contractor* shall pay such amount to the *Employer* within 10 (ten) Business Days of the determination made pursuant to such determination and an accompanying valid Tax Invoice.

Payment of Non-compliance Penalties:

- a) Subject to Clause i) above, the *Contractor* shall pay the Non-compliance Penalty indicated in the Non-compliance Penalty Certificate within 10 (ten) Business Days of the *Employer* issuing a valid Tax Invoice to the *Contractor* for the amount set out in that certificate. If the *Employer* does not issue a valid Tax Invoice to the *Contractor* for Non-compliance Penalties accrued during any relevant period, those Non-compliance Penalties shall be carried forward to the next period.
- b) The *Contractor* shall pay the amount due within 10 (ten) days after receipt of a valid Tax Invoice from the *Employer*, failing which Transnet shall, without prejudice to any other rights of the *Employer* under this Agreement, be entitled to call for payment which may be in any form the *Employer* deems reasonable and appropriate.
- c) It is agreed that the *Employer*, the DTI, the South African Bureau of Standards and/or any of their appointed agents shall be entitled to monitor, evaluate and audit the *Contractor's* compliance with its obligations under the Local Content Plan. To this end, the *Contractor* shall provide its full cooperation to the respective bodies referred to in this clause to ensure that effective monitoring, evaluation and auditing takes place.

The Non Compliance Penalties set forth in this Clause are stated exclusive of VAT. Any VAT payable on Non Compliance Penalties will be for the account of the *Contractor*.



TRANSNET PORT TERMINALS

TENDER NUMBER: TPT/2024/03/0066/60631/RFP

DESCRIPTION OF THE SERVICES: FOR THE SUPPLY OF SERVICES TO REFURBISH STACKER RECLAIMER 3 AT THE SALDANHA IRON ORE TERMINAL FOR TRANSNET SOC LTD (REG.NO.1990/000900/30) OPERATING AS TRANSNET PORT TERMINALS, (HEREINAFTER REFERRED TO AS "TPT"), AS A ONCE OFF SUPPLY.

T2.2-12 Schedule: B-BBEE Status Level 1 and 2

In an endeavour to grow and develop Black Owned (BO) companies as well as to ensure that Transnet meets its Shareholder Compact Objectives, Potential Tenderers are required to meet the B-BBEE Status Level 1 and 2

It is a specific tendering condition that tenderers:

- Have a minimum B-BBEE status level of 1 and 2



T2.2-14: Confirmation to submit proof of Professional Registration

Confirmation to submit proof or professional registration	State Yes or No
The Tenderer is to confirm that proof of valid SACPCMP registration for either the Project Manager or the Construction Manager to be assigned to the project will be submitted to Transnet within one week of receiving notice to provide such as a condition of award.	



DESCRIPTION OF THE SERVICES: FOR THE SUPPLY OF SERVICES TO REFURBISH STACKER RECLAIMER 3 AT THE SALDANHA IRON ORE TERMINAL FOR TRANSNET SOC LTD (REG.NO.1990/000900/30) OPERATING AS TRANSNET PORT TERMINALS, (HEREINAFTER REFERRED TO AS "TPT"), AS A ONCE OFF SUPPLY.

T2.2-15 : ANNEX G Compulsory Enterprise Questionnaire

The following particulars hereunder must be furnished.

In the case of a Joint Venture, separate enterprise questionnaires in respect of each partner/member must be completed and submitted.

Section 1: Name of enterprise: _____

Section 2: VAT registration number, if any: _____

Section 3: CIDB registration number, if any: _____

Section 4: CSD number: _____

Section 5: Particulars of sole proprietors and partners in partnerships

Name	Identity number	Personal income tax number

* Complete only if sole proprietor or partnership and attach separate page if more than 3 partners

Section 6: Particulars of companies and close corporations

Company registration number _____

Close corporation number _____

Tax reference number: _____

Section 7: The attached SBD4 must be completed for each tender and be attached as a tender requirement.

Section 8: The attached SBD 6 must be completed for each tender and be attached as a requirement.



DESCRIPTION OF THE SERVICES: FOR THE SUPPLY OF SERVICES TO REFURBISH STACKER RECLAIMER 3 AT THE SALDANHA IRON ORE TERMINAL FOR TRANSNET SOC LTD (REG.NO.1990/000900/30) OPERATING AS TRANSNET PORT TERMINALS, (HEREINAFTER REFERRED TO AS "TPT"), AS A ONCE OFF SUPPLY.

The undersigned, who warrants that he / she is duly authorised to do so on behalf of the enterprise:

- i) authorizes the Employer to obtain a tax clearance certificate from the South African Revenue Services that my / our tax matters are in order;
- ii) confirms that the neither the name of the enterprise or the name of any partner, manager, director or other person, who wholly or partly exercises, or may exercise, control over the enterprise appears on the Register of Tender Defaulters established in terms of the Prevention and Combating of Corrupt Activities Act of 2004;
- iii) confirms that no partner, member, director or other person, who wholly or partly exercises, or may exercise, control over the enterprise appears, has within the last five years been convicted of fraud or corruption;
- iv) confirms that I / we are not associated, linked or involved with any other tendering entities submitting tender offers and have no other relationship with any of the tenderers or those responsible for compiling the scope of work that could cause or be interpreted as a conflict of interest; and
- v) confirms that the contents of this questionnaire are within my personal knowledge and are to the best of my belief both true and correct.

Signed	_____	Date	_____
Name	_____	Position	_____
Enterprise name	_____		



DESCRIPTION OF THE SERVICES: FOR THE SUPPLY OF SERVICES TO REFURBISH STACKER RECLAIMER 3 AT THE SALDANHA IRON ORE TERMINAL FOR TRANSNET SOC LTD (REG.NO.1990/000900/30) OPERATING AS TRANSNET PORT TERMINALS, (HEREINAFTER REFERRED TO AS "TPT"), AS A ONCE OFF SUPPLY.

SBD 6.1

PREFERENCE POINTS CLAIM FORM

This preference form must form part of all bids invited. It contains general information and serves as a claim for preference points for Specific Goals contribution. Transnet will award preference points to companies who provide valid proof of evidence as per the table of evidence in paragraph 4.1 below.

1. GENERAL CONDITIONS

1.1 The following preference point systems are applicable to all bids:

- the 80/20 system for requirements with a Rand value of up to R50 000 000 (all applicable taxes included); and
- the 90/10 system for requirements with a Rand value above R50 000 000 (all applicable taxes included).

1.2 The value of this bid is estimated to **exceed** R50 000 000 (all applicable taxes included) and therefore the 90/10 preference point system shall be applicable. Despite the stipulated preference point system, Transnet shall use the lowest acceptable bid to determine the applicable preference point system in a situation where all received acceptable bids are received outside the stated preference point system.

1.3 Preference points for this bid shall be awarded for:

- (a) Price;
- (b) B-BBEE Status Level of Contribution; and
- (c) Any other specific goal determined in the Transnet preferential procurement policy

1.4 The maximum points for this bid are allocated as follows:

	POINTS
PRICE	90
B-BBEE STATUS LEVEL OF CONTRIBUTION Level 1-2	10
SUBCONTRACTING 30% OF THE VALUE OF THE CONTRACT TO EME'S AND QSE'S 51% LOCAL CONTENT	
Total points for Price and B-BBEE must not exceed	100



DESCRIPTION OF THE SERVICES: FOR THE SUPPLY OF SERVICES TO REFURBISH STACKER RECLAIMER 3 AT THE SALDANHA IRON ORE TERMINAL FOR TRANSNET SOC LTD (REG.NO.1990/000900/30) OPERATING AS TRANSNET PORT TERMINALS, (HEREINAFTER REFERRED TO AS "TPT"), AS A ONCE OFF SUPPLY.

- 1.5 Failure on the part of a bidder to submit proof of evidence required for any of the specific goals together with the bid will be interpreted to mean that preference points for that specific goal are not claimed.
- 1.6 The purchaser reserves the right to require of a bidder, either before a bid is adjudicated or at any time subsequently, to substantiate any claim in regard to preferences, in any manner required by the purchaser.

2. DEFINITIONS

- (a) **"all applicable taxes"** includes value-added tax, pay as you earn, income tax, unemployment insurance fund contributions and skills development levies;
- (b) **"B-BBEE"** means broad-based black economic empowerment as defined in section 1 of the Broad-Based Black Economic Empowerment Act;
- (c) **"B-BBEE status level of contributor"** means the B-BBEE status received by a measured entity based on its overall performance using the relevant scorecard contained in the Codes of Good Practice on Black Economic Empowerment, issued in terms of section 9(1) of the Broad-Based Black Economic Empowerment Act;
- (d) **"bid"** means a written offer in a prescribed or stipulated form in response to an invitation by an organ of state for the supply/provision of services, works or goods, through price quotations, advertised competitive bidding processes or proposals;
- (e) **"Broad-Based Black Economic Empowerment Act"** means the Broad-Based Black Economic Empowerment Act, 2003 (Act No. 53 of 2003);
- (f) **"EME"** means an Exempted Micro Enterprise as defines by Codes of Good Practice under section 9 (1) of the Broad-Based Black Economic Empowerment Act, 2003 (Act No. 53 of 2003);
- (g) **"functionality"** means the ability of a bidder to provide goods or services in accordance with specification as set out in the bid documents
- (h) **"Price"** includes all applicable taxes less all unconditional discounts.
- (i) **"Proof of B-BBEE Status Level of Contributor"**
 - i) the B-BBBEE status level certificate issued by an authorised body or person;
 - ii) a sworn affidavit as prescribed by the B-BBEE Codes of Good Practice; or
 - iii) any other requirement prescribed in terms of the B-BBEE Act.
- (j) **"QSE"** means a Qualifying Small Enterprise as defines by Codes of Good Practice under section 9 (1) of the Broad-Based Black Economic Empowerment Act, 2003 (Act No. 53 of 2003);
- (k) **"rand value"** means the total estimated value of a contract in South African currency, calculated at the time of bid invitations, and includes all applicable taxes and excise duties.
- (l) **"Specific goals"** means targeted advancement areas or categories of persons or



DESCRIPTION OF THE SERVICES: FOR THE SUPPLY OF SERVICES TO REFURBISH STACKER RECLAIMER 3 AT THE SALDANHA IRON ORE TERMINAL FOR TRANSNET SOC LTD (REG.NO.1990/000900/30) OPERATING AS TRANSNET PORT TERMINALS, (HEREINAFTER REFERRED TO AS "TPT"), AS A ONCE OFF SUPPLY.

groups either previously disadvantaged or falling within the scope of the Reconstruction and Development Programme identified by Transnet to be given preference in allocation of procurement contracts in line with section 2(1) of the PPPFA.

3. POINTS AWARDED FOR PRICE

3.1 THE 90/10 PREFERENCE POINT SYSTEMS

A maximum of 90 points is allocated for price on the following basis:

90/10

$$P_s = 90 \left(1 - \frac{P_t - P_{\min}}{P_{\min}} \right)$$

Where

P_s = Points scored for comparative price of bid under consideration

P_t = Comparative price of bid under consideration

P_{\min} = Comparative price of lowest acceptable bid

4. EVIDENCE REQUIRED FOR CLAIMING SPECIFIC GOALS

4.1 In terms of Transnet Preferential Procurement Policy (TPPP) and Procurement Manuals, preference points must be awarded to a bidder for providing evidence in accordance with the table below::

Specific Goals	Acceptable Evidence
B-BBEE Status contributor	B-BBEE Certificate / Sworn- Affidavit / B-BBEE CIPC Certificate (in case of JV, a consolidated scorecard will be accepted) as per DTIC guideline
Local Content and Local Production	Returnable Local Content and production Annexures
<p>The promotion of supplier development through sub-contracting or JV for a minimum of 30% of the value of a contract to South African Companies which are:</p> <p>I. 30% Black Women, 51% Black Youth and 51% Black people with disabilities</p> <p>II. Entities with a specified minimum B-BBEE level (1 and 2)</p> <p>III. EMEs and/or QSEs who are 51% black-owned</p>	Sub-contracting agreements and Declaration / Joint Venture Agreement and CIPC – B-BBEE Certificate / Sworn- Affidavit / B-BBEE CIPC Certificate as per DTIC guideline



DESCRIPTION OF THE SERVICES: FOR THE SUPPLY OF SERVICES TO REFURBISH STACKER RECLAIMER 3 AT THE SALDANHA IRON ORE TERMINAL FOR TRANSNET SOC LTD (REG.NO.1990/000900/30) OPERATING AS TRANSNET PORT TERMINALS, (HEREINAFTER REFERRED TO AS "TPT"), AS A ONCE OFF SUPPLY.

- 4.2 The table below indicates the required proof of B-BBEE status depending on the category of enterprises:

Enterprise	B-BBEE Certificate & Sworn Affidavit
Large	Certificate issued by SANAS accredited verification agency
QSE	Certificate issued by SANAS accredited verification agency Sworn Affidavit signed by the authorised QSE representative and attested by a Commissioner of Oaths confirming annual turnover and black ownership (only black-owned QSEs - 51% to 100% Black owned) [Sworn affidavits must substantially comply with the format that can be obtained on the DTI's website at www.dti.gov.za/economic_empowerment/bee_codes.jsp .]
EME¹	Sworn Affidavit signed by the authorised EME representative and attested by a Commissioner of Oaths confirming annual turnover and black ownership Certificate issued by CIPC (formerly CIPRO) confirming annual turnover and black ownership Certificate issued by SANAS accredited verification agency only if the EME is being measured on the QSE scorecard

- 4.3 A trust, consortium or joint venture (including unincorporated consortia and joint ventures) must submit a consolidated B-BBEE Status Level verification certificate for every separate bid.
- 4.4 Tertiary Institutions and Public Entities will be required to submit their B-BBEE status level certificates in terms of the specialized scorecard contained in the B-BBEE Codes of Good Practice.
- 4.5 A person will not be awarded points for B-BBEE status level if it is indicated in the bid documents that such a bidder intends sub-contracting more than 25% of the value of the contract to any other enterprise that does not qualify for at least the points that such a bidder qualifies for, unless the intended sub-contractor is an EME that has the capability and ability to execute the sub-contract.
- 4.6 A person awarded a contract may not sub-contract more than 25% of the value of the contract to any other enterprise that does not have an equal or higher B-BBEE status level than the person concerned, unless the contract is sub-contracted to an EME that has the capability and ability to execute the sub-contract.
- 4.7 Bidders are to note that the rules pertaining to B-BBEE verification and other B-BBEE requirements may be changed from time to time by regulatory bodies such as National

¹ In terms of the Implementation Guide: Preferential Procurement Regulations, 2017, Version 2, paragraph 11.11 provides that in the Transport Sector, EMEs can provide a letter from accounting officer or get verified and be issued with a B-BBEE certificate by SANAS accredited professional or agency as the Transport Sector Code has not been aligned to the generic Codes. EMEs in the Transport Sector are not allowed to provide a sworn affidavit as the generic codes are not applicable to them.



DESCRIPTION OF THE SERVICES: FOR THE SUPPLY OF SERVICES TO REFURBISH STACKER RECLAIMER 3 AT THE SALDANHA IRON ORE TERMINAL FOR TRANSNET SOC LTD (REG.NO.1990/000900/30) OPERATING AS TRANSNET PORT TERMINALS, (HEREINAFTER REFERRED TO AS "TPT"), AS A ONCE OFF SUPPLY.

Treasury or the DTI. It is the Bidder's responsibility to ensure that his/her bid complies fully with all B-BBEE requirements at the time of the submission of the bid.

5. BID DECLARATION

5.1 Bidders who claim points in respect of B-BBEE Status Level of Contribution must complete the following:

6. B-BBEE STATUS LEVEL OF CONTRIBUTION CLAIMED IN TERMS OF PARAGRAPHS 1.4 AND 6.1

6.1 B-BBEE Status Level of Contribution: . =(maximum of 10 points)

(Points claimed in respect of paragraph 6.1 must be in accordance with the table reflected in paragraph 4.1 and must be substantiated by relevant proof of B-BBEE status level of contributor.

7. SUB-CONTRACTING

7.1 Will any portion of the contract be sub-contracted?

(***Tick applicable box***)

YES		NO	
-----	--	----	--

7.1.1 If yes, indicate:

- i) What percentage of the contract will be subcontracted.....%
- ii) The name of the sub-contractor.....
- iii) The B-BBEE status level of the sub-contractor.....
- iv) Whether the sub-contractor is an EME or QSE.

(***Tick applicable box***)

YES		NO	
-----	--	----	--

8. DECLARATION WITH REGARD TO COMPANY/FIRM



DESCRIPTION OF THE SERVICES: FOR THE SUPPLY OF SERVICES TO REFURBISH STACKER RECLAIMER 3 AT THE SALDANHA IRON ORE TERMINAL FOR TRANSNET SOC LTD (REG.NO.1990/000900/30) OPERATING AS TRANSNET PORT TERMINALS, (HEREINAFTER REFERRED TO AS "TPT"), AS A ONCE OFF SUPPLY.

8.1 Name of company/firm:.....

8.2 VAT registration number:.....

8.3 Company registration number:.....

8.4 TYPE OF COMPANY/ FIRM

- Partnership/Joint Venture / Consortium
- One person business/sole propriety
- Close corporation
- Company
- (Pty) Limited

[TICK APPLICABLE BOX]

8.5 DESCRIBE PRINCIPAL BUSINESS ACTIVITIES

.....

8.6 COMPANY CLASSIFICATION

- Manufacturer
- Supplier
- Professional Service provider
- Other Service providers, e.g. transporter, etc.

[TICK APPLICABLE BOX]

8.7 Total number of years the company/firm has been in business:.....

8.8 I/we, the undersigned, who is / are duly authorised to do so on behalf of the company/firm, certify that the points claimed, based on the B-BBE status level of contribution indicated in paragraphs 1.4 and 6.1 of the foregoing certificate, qualifies the company/ firm for the preference(s) shown and I / we acknowledge that:

- i) The information furnished is true and correct;
- ii) The preference points claimed are in accordance with the General Conditions as indicated in paragraph 1 of this form;
- iii) In the event of a contract being awarded as a result of points claimed as shown in paragraph 1.4 and 6.1, the contractor may be required to furnish documentary proof to the satisfaction of the purchaser that the claims are correct;
- iv) If a bidder submitted false information regarding its B-BBEE status level of contributor,, which will affect or has affected the evaluation of a bid, or where a bidder has failed to declare any subcontracting arrangements or any of the conditions of contract have not been fulfilled, the purchaser may, in addition to any other remedy it may have
 - (a) disqualify the person from the bidding process;



DESCRIPTION OF THE SERVICES: FOR THE SUPPLY OF SERVICES TO REFURBISH STACKER RECLAIMER 3 AT THE SALDANHA IRON ORE TERMINAL FOR TRANSNET SOC LTD (REG.NO.1990/000900/30) OPERATING AS TRANSNET PORT TERMINALS, (HEREINAFTER REFERRED TO AS "TPT"), AS A ONCE OFF SUPPLY.

- (b) recover costs, losses or damages it has incurred or suffered as a result of that person’s conduct;
- (c) cancel the contract and claim any damages which it has suffered as a result of having to make less favourable arrangements due to such cancellation;
- (d) if the successful bidder subcontracted a portion of the bid to another person without disclosing it, Transnet reserves the right to penalise the bidder up to 10 percent of the value of the contract;
- (e) recommend that the bidder or contractor, its shareholders and directors, or only the shareholders and directors who acted on a fraudulent basis, be restricted by the National Treasury from obtaining business from any organ of state for a period not exceeding 10 years, after the audi alteram partem (hear the other side) rule has been applied; and
- (f) forward the matter for criminal prosecution.

WITNESSES

1.

2.

.....

SIGNATURE(S) OF BIDDERS(S)

DATE:

BIDDER’S DISCLOSURE

1. PURPOSE OF THE FORM

Any person (natural or juristic) may make an offer or offers in terms of this invitation to bid. In line with the principles of transparency, accountability, impartiality, and ethics as enshrined in the Constitution of the Republic of South Africa and further expressed in various pieces of legislation, it is required for the bidder to make this declaration in respect of the details required hereunder.

Where a person/s are listed in the Register for Tender Defaulters and / or the List of Restricted Suppliers, that person will automatically be disqualified from the bid process.

2. Bidder’s declaration

2.1 Is the bidder, or any of its directors / trustees / shareholders / members / partners or



DESCRIPTION OF THE SERVICES: FOR THE SUPPLY OF SERVICES TO REFURBISH STACKER RECLAIMER 3 AT THE SALDANHA IRON ORE TERMINAL FOR TRANSNET SOC LTD (REG.NO.1990/000900/30) OPERATING AS TRANSNET PORT TERMINALS, (HEREINAFTER REFERRED TO AS "TPT"), AS A ONCE OFF SUPPLY.

any person having a controlling interest² in the enterprise, employed by the state?

YES/NO

2.1.1 If so, furnish particulars of the names, individual identity numbers, and, if applicable, state employee numbers of sole proprietor/ directors / trustees / shareholders / members/ partners or any person having a controlling interest in the enterprise, in table below.

Full Name	Identity Number	Name of State institution

2.2

Do you, or any person

connected with the bidder, have a relationship with any person who is employed by the procuring institution? **YES/NO**

2.2.1 If so, furnish particulars:

.....

2.3 Does the bidder or any of its directors / trustees / shareholders / members / partners or any person having a controlling interest in the enterprise have any interest in any other related enterprise whether or not they are bidding for this contract?

YES/NO

2.3.1 If so, furnish particulars:

² the power, by one person or a group of persons holding the majority of the equity of an enterprise, alternatively, the person/s having the deciding vote or power to influence or to direct the course and decisions of the enterprise.



DESCRIPTION OF THE SERVICES: FOR THE SUPPLY OF SERVICES TO REFURBISH STACKER RECLAIMER 3 AT THE SALDANHA IRON ORE TERMINAL FOR TRANSNET SOC LTD (REG.NO.1990/000900/30) OPERATING AS TRANSNET PORT TERMINALS, (HEREINAFTER REFERRED TO AS "TPT"), AS A ONCE OFF SUPPLY.

.....
.....

3 DECLARATION

I, the undersigned, (name)..... in submitting the accompanying bid, do hereby make the following statements that I certify to be true and complete in every respect:

- 3.1 I have read and I understand the contents of this disclosure;
- 3.2 I understand that the accompanying bid will be disqualified if this disclosure is found not to be true and complete in every respect;
- 3.3 The bidder has arrived at the accompanying bid independently from, and without consultation, communication, agreement or arrangement with any competitor. However, communication between partners in a joint venture or consortium³ will not be construed as collusive bidding.
- 3.4 In addition, there have been no consultations, communications, agreements or arrangements with any competitor regarding the quality, quantity, specifications, prices, including methods, factors or formulas used to calculate prices, market allocation, the intention or decision to submit or not to submit the bid, bidding with the intention not to win the bid and conditions or delivery particulars of the products or services to which this bid invitation relates.
- 3.4 The terms of the accompanying bid have not been, and will not be, disclosed by the bidder, directly or indirectly, to any competitor, prior to the date and time of the official bid opening or of the awarding of the contract.
- 3.5 There have been no consultations, communications, agreements or arrangements made by the bidder with any official of the procuring institution in relation to this procurement process prior to and during the bidding process except to provide clarification on the bid submitted where so required by the institution; and the bidder was not involved in the drafting of the specifications or terms of reference for this bid.

³ Joint venture or Consortium means an association of persons for the purpose of combining their expertise, property, capital, efforts, skill and knowledge in an activity for the execution of a contract.



DESCRIPTION OF THE SERVICES: FOR THE SUPPLY OF SERVICES TO REFURBISH STACKER RECLAIMER 3 AT THE SALDANHA IRON ORE TERMINAL FOR TRANSNET SOC LTD (REG.NO.1990/000900/30) OPERATING AS TRANSNET PORT TERMINALS, (HEREINAFTER REFERRED TO AS "TPT"), AS A ONCE OFF SUPPLY.

3.6 I am aware that, in addition and without prejudice to any other remedy provided to combat any restrictive practices related to bids and contracts, bids that are suspicious will be reported to the Competition Commission for investigation and possible imposition of administrative penalties in terms of section 59 of the Competition Act No 89 of 1998 and or may be reported to the National Prosecuting Authority (NPA) for criminal investigation and or may be restricted from conducting business with the public sector for a period not exceeding ten (10) years in terms of the Prevention and Combating of Corrupt Activities Act No 12 of 2004 or any other applicable legislation.

I CERTIFY THAT THE INFORMATION FURNISHED IN PARAGRAPHS 1, 2 and 3 ABOVE IS CORRECT.

I ACCEPT THAT THE STATE MAY REJECT THE BID OR ACT AGAINST ME IN TERMS OF PARAGRAPH 6 OF PFMA SCM INSTRUCTION 03 OF 2021/22 ON PREVENTING AND COMBATING ABUSE IN THE SUPPLY CHAIN MANAGEMENT SYSTEM SHOULD THIS DECLARATION PROVE TO BE FALSE.

.....

Signature

.....

Date

.....

Position

.....

Name of bidder

TRANSNET PORT TERMINALS

TENDER NUMBER: TPT/2024/03/0066/60631/RFP

DESCRIPTION OF THE SERVICES: FOR THE SUPPLY OF SERVICES TO REFURBISH STACKER RECLAIMER 3 AT THE SALDANHA IRON ORE TERMINAL FOR TRANSNET SOC LTD (REG.NO.1990/000900/30) OPERATING AS TRANSNET PORT TERMINALS, (HEREINAFTER REFERRED TO AS "TPT"), AS A ONCE OFF SUPPLY.



T2.2-16 NON-DISCLOSURE AGREEMENT

[..... 2024]



Note to tenderers: This Non-Disclosure Agreement is to be completed and signed by an authorised signatory:

THIS AGREEMENT is made effective as of day of 20..... by and between:

TRANSNET SOC LTD

(Registration No. 1990/000900/30), a company incorporated and existing under the laws of South Africa, having its principal place of business at Transnet Corporate Centre 138 Eloff Street , Braamfontein , Johannesburg 2000

and

.....
.....

(Registration No.), a private company incorporated and existing under the laws of South Africa having its principal place of business at

.....
.....
.....
.....

WHEREAS

Transnet and the Company wish to exchange Information [as defined below] and it is envisaged that each party may from time to time receive Information relating to the other in respect thereof. In consideration of each party making available to the other such Information, the parties jointly agree that any dealings between them shall be subject to the terms and conditions of this Agreement which themselves will be subject to the parameters of the Tender Document.

IT IS HEREBY AGREED

1. INTERPRETATION

In this Agreement:

DESCRIPTION OF THE SERVICES: FOR THE SUPPLY OF SERVICES TO REFURBISH STACKER RECLAIMER 3 AT THE SALDANHA IRON ORE TERMINAL FOR TRANSNET SOC LTD (REG.NO.1990/000900/30) OPERATING AS TRANSNET PORT TERMINALS, (HEREINAFTER REFERRED TO AS "TPT"), AS A ONCE OFF SUPPLY.



- 1.1 **Agents** mean directors, officers, employees, agents, professional advisers, contractors or sub-contractors, or any Group member;
- 1.2 **Bid** or **Bid Document** (hereinafter Tender) means Transnet's Request for Information [RFI] Request for Proposal [RFP] or Request for Quotation [RFQ], as the case may be;
- 1.3 **Confidential Information** means any information or other data relating to one party [the **Disclosing Party**] and/or the business carried on or proposed or intended to be carried on by that party and which is made available for the purposes of the Bid to the other party [the **Receiving Party**] or its Agents by the Disclosing Party or its Agents or recorded in agreed minutes following oral disclosure and any other information otherwise made available by the Disclosing Party or its Agents to the Receiving Party or its Agents, whether before, on or after the date of this Agreement, and whether in writing or otherwise, including any information, analysis or specifications derived from, containing or reflecting such information but excluding information which:
- 1.3.1 is publicly available at the time of its disclosure or becomes publicly available [other than as a result of disclosure by the Receiving Party or any of its Agents contrary to the terms of this Agreement]; or
- 1.3.2 was lawfully in the possession of the Receiving Party or its Agents [as can be demonstrated by its written records or other reasonable evidence] free of any restriction as to its use or disclosure prior to its being so disclosed; or
- 1.3.3 following such disclosure, becomes available to the Receiving Party or its Agents [as can be demonstrated by its written records or other reasonable evidence] from a source other than the Disclosing Party or its Agents, which source is not bound by any duty of confidentiality owed, directly or indirectly, to the Disclosing Party in relation to such information;
- 1.4 **Group** means any subsidiary, any holding company and any subsidiary of any holding company of either party; and
- 1.5 **Information** means all information in whatever form including, without limitation, any information relating to systems, operations, plans, intentions, market opportunities, know-how, trade secrets and business affairs whether in writing, conveyed orally or by machine-readable medium.

2. CONFIDENTIAL INFORMATION

- 2.1 All Confidential Information given by one party to this Agreement [the **Disclosing Party**] to the other party [the **Receiving Party**] will be treated by the Receiving Party as secret and confidential and will not, without the Disclosing Party's written consent, directly or indirectly communicate or disclose [whether in writing or orally or in any other manner] Confidential Information to any other person other than in accordance with the terms of this Agreement.
- 2.2 The Receiving Party will only use the Confidential Information for the sole purpose of technical and commercial discussions between the parties in relation to the Tender or for the subsequent performance of any contract between the parties in relation to the Tender.
- 2.3 Notwithstanding clause 2.1 above, the Receiving Party may disclose Confidential Information:
- 2.3.1 to those of its Agents who strictly need to know the Confidential Information for the sole purpose set out in clause 2.2 above, provided that the Receiving Party shall ensure that such Agents are made aware prior to the disclosure of any part of the Confidential Information that the same is confidential and that they owe a duty of confidence to the Disclosing Party. The Receiving Party shall at all times remain liable for any actions of such Agents that would constitute a breach of this Agreement; or
- 2.3.2 to the extent required by law or the rules of any applicable regulatory authority, subject to clause 2.4 below.
- 2.4 In the event that the Receiving Party is required to disclose any Confidential Information in accordance with clause 2.3.2 above, it shall promptly notify the Disclosing Party and cooperate with the Disclosing Party regarding the form, nature, content and purpose of such disclosure or any action which the Disclosing Party may reasonably take to challenge the validity of such requirement.

DESCRIPTION OF THE SERVICES: FOR THE SUPPLY OF SERVICES TO REFURBISH STACKER RECLAIMER 3 AT THE SALDANHA IRON ORE TERMINAL FOR TRANSNET SOC LTD (REG.NO.1990/000900/30) OPERATING AS TRANSNET PORT TERMINALS, (HEREINAFTER REFERRED TO AS "TPT"), AS A ONCE OFF SUPPLY.



- 2.5 In the event that any Confidential Information shall be copied, disclosed or used otherwise than as permitted under this Agreement then, upon becoming aware of the same, without prejudice to any rights or remedies of the Disclosing Party, the Receiving Party shall as soon as practicable notify the Disclosing Party of such event and if requested take such steps [including the institution of legal proceedings] as shall be necessary to remedy [if capable of remedy] the default and/or to prevent further unauthorised copying, disclosure or use.
- 2.6 All Confidential Information shall remain the property of the Disclosing Party and its disclosure shall not confer on the Receiving Party any rights, including intellectual property rights over the Confidential Information whatsoever, beyond those contained in this Agreement.

3. RECORDS AND RETURN OF INFORMATION

- 3.1 The Receiving Party agrees to ensure proper and secure storage of all Information and any copies thereof.
- 3.2 The Receiving Party shall keep a written record, to be supplied to the Disclosing Party upon request, of the Confidential Information provided and any copies made thereof and, so far as is reasonably practicable, of the location of such Confidential Information and any copies thereof.
- 3.3 The Company shall, within 7 [seven] days of receipt of a written demand from Transnet:
- 3.3.1 return all written Confidential Information [including all copies]; and
- 3.3.2 expunge or destroy any Confidential Information from any computer, word processor or other device whatsoever into which it was copied, read or programmed by the Company or on its behalf.
- 3.4 The Company shall on request supply a certificate signed by a director as to its full compliance with the requirements of clause 3.3.2 above.

4. ANNOUNCEMENTS

- 4.1 Neither party will make or permit to be made any announcement or disclosure of its prospective interest in the Tender without the prior written consent of the other party.

- 4.2 Neither party shall make use of the other party's name or any information acquired through its dealings with the other party for publicity or marketing purposes without the prior written consent of the other party.

5. DURATION

The obligations of each party and its Agents under this Agreement shall survive the termination of any discussions or negotiations between the parties regarding the Tender and continue thereafter for a period of 5 [five] years.

6. PRINCIPAL

Each party confirms that it is acting as principal and not as nominee, agent or broker for any other person and that it will be responsible for any costs incurred by it or its advisers in considering or pursuing the Tender and in complying with the terms of this Agreement.

7. ADEQUACY OF DAMAGES

Nothing contained in this Agreement shall be construed as prohibiting the Disclosing Party from pursuing any other remedies available to it, either at law or in equity, for any such threatened or actual breach of this Agreement, including specific performance, recovery of damages or otherwise.

8. PRIVACY AND DATA PROTECTION

- 8.1 The Receiving Party undertakes to comply with South Africa's general privacy protection in terms Section 14 of the Bill of Rights in connection with this Tender and shall procure that its personnel shall observe the provisions of such Act [as applicable] or any amendments and re-enactments thereof and any regulations made pursuant thereto.
- 8.2 The Receiving Party warrants that it and its Agents have the appropriate technical and organisational measures in place against unauthorised or unlawful processing of data relating to the Tender and against accidental loss or destruction of, or damage to such data held or processed by them.

9. GENERAL

- 9.1 Neither party may assign the benefit of this Agreement, or any interest hereunder, except with the prior written consent of the other, save that Transnet may assign this Agreement at any time to any member of the Transnet Group.



DESCRIPTION OF THE SERVICES: FOR THE SUPPLY OF SERVICES TO REFURBISH STACKER RECLAIMER 3 AT THE SALDANHA IRON ORE TERMINAL FOR TRANSNET SOC LTD (REG.NO.1990/000900/30) OPERATING AS TRANSNET PORT TERMINALS, (HEREINAFTER REFERRED TO AS "TPT"), AS A ONCE OFF SUPPLY.

- 9.2 No failure or delay in exercising any right, power or privilege under this Agreement will operate as a waiver of it, nor will any single or partial exercise of it preclude any further exercise or the exercise of any right, power or privilege under this Agreement or otherwise.
- 9.3 The provisions of this Agreement shall be severable in the event that any of its provisions are held by a court of competent jurisdiction or other applicable authority to be invalid, void or otherwise unenforceable, and the remaining provisions shall remain enforceable to the fullest extent permitted by law.
- 9.4 This Agreement may only be modified by a written agreement duly signed by persons authorised on behalf of each party.
- 9.5 Nothing in this Agreement shall constitute the creation of a partnership, joint venture or agency between the parties.
- 9.6 This Agreement will be governed by and construed in accordance with South African law and the parties irrevocably submit to the exclusive jurisdiction of the South African courts.

Signed	Date
.....
Name	Position
.....
Tenderer	
.....	



T2.2-17: RFP DECLARATION FORM

NAME OF COMPANY: _____

We _____ do hereby certify that:

1. Transnet has supplied and we have received appropriate tender offers to any/all questions (as applicable) which were submitted by ourselves for tender clarification purposes;
2. we have received all information we deemed necessary for the completion of this Tender;
3. at no stage have we received additional information relating to the subject matter of this tender from Transnet sources, other than information formally received from the designated Transnet contact(s) as nominated in the tender documents;
4. we are satisfied, insofar as our company is concerned, that the processes and procedures adopted by Transnet in issuing this tender and the requirements requested from tenderers in responding to this tender have been conducted in a fair and transparent manner; and
5. furthermore, we acknowledge that a direct relationship exists between a family member and/or an owner / member / director / partner / shareholder (unlisted companies) of our company and an employee or board member of the Transnet Group as indicated below:

[Respondent to indicate if this section is not applicable]

FULL NAME OF OWNER/MEMBER/DIRECTOR/

PARTNER/SHAREHOLDER:

ADDRESS:

Indicate nature of relationship with Transnet:



[Failure to furnish complete and accurate information in this regard may lead to the disqualification of your response and may preclude a Respondent from doing future business with Transnet]

We declare, to the extent that we are aware or become aware of any relationship between ourselves and Transnet (other than any existing and appropriate business relationship with Transnet) which could unfairly advantage our company in the forthcoming adjudication process, we shall notify Transnet immediately in writing of such circumstances.

- 6. We accept that any dispute pertaining to this tender will be resolved through the Ombudsman process and will be subject to the Terms of Reference of the Ombudsman. The Ombudsman process must first be exhausted before judicial review of a decision is sought. (Refer "Important Notice to respondents" below).
- 7. We further accept that Transnet reserves the right to reverse a tender award or decision based on the recommendations of the Ombudsman without having to follow a formal court process to have such award or decision set aside.
- 8. We have acquainted ourselves and agree with the content of T2.2-20 "Service Provider Integrity Pact".

For and on behalf of duly authorised thereto
Name:
Signature:
Date:

IMPORTANT NOTICE TO TENDERERS



- Transnet has appointed a Procurement Ombudsman to investigate any material complaint in respect of tenders exceeding R5,000,000.00 (five million S.A. Rand) in value. Should a Tenderer have any material concern regarding an tender process which meets this value threshold, a complaint may be lodged with Transnet's Procurement Ombudsman for further investigation.
- It is incumbent on the Tenderer to familiarise himself/herself with the Terms of Reference for the Transnet Procurement Ombudsman, details of which are available for review at Transnet's website www.transnet.net.
- An official complaint form may be downloaded from this website and submitted, together with any supporting documentation, within the prescribed period, to procurement.ombud@transnet.net
- For transactions below the R5,000,000.00 (five million S.A. Rand) threshold, a complaint may be lodged with the Chief Procurement Officer of the relevant Transnet Operating Division.
- All Tenderers should note that a complaint must be made in good faith. If a complaint is made in bad faith, Transnet reserves the right to place such a tenderer on its List of Excluded Bidders.



T2.2-18: REQUEST FOR PROPOSAL – BREACH OF LAW

NAME OF COMPANY: _____

I / We _____ do hereby certify that ***I/we have/have not been*** found guilty during the preceding 5 (five) years of a serious breach of law, including but not limited to a breach of the Competition Act, 89 of 1998, by a court of law, tribunal or other administrative body. The type of breach that the Tenderer is required to disclose excludes relatively minor offences or misdemeanours, e.g. traffic offences.

Where found guilty of such a serious breach, please disclose:

NATURE OF BREACH:

DATE OF BREACH:

Furthermore, I/we acknowledge that Transnet SOC Ltd reserves the right to exclude any Tenderer from the tendering process, should that person or company have been found guilty of a serious breach of law, tribunal or regulatory obligation.

Signed on this _____ day of _____ 20____

SIGNATURE OF TENDER



T2.2-19 Certificate of Acquaintance with Tender Documents

NAME OF TENDERING ENTITY:

1. By signing this certificate I/we acknowledge that I/we have made myself/ourselves thoroughly familiar with, and agree with all the conditions governing this RFP. This includes those terms and conditions of the Contract, the Supplier Integrity Pact, Non-Disclosure Agreement etc. contained in any printed form stated to form part of the documents thereof, but not limited to those listed in this clause.
2. I/we furthermore agree that Transnet SOC Ltd shall recognise no claim from me/us for relief based on an allegation that I/we overlooked any tender/contract condition or failed to take it into account for the purpose of calculating my/our offered prices or otherwise.
3. I/we understand that the accompanying Tender will be disqualified if this Certificate is found not to be true and complete in every respect.
4. For the purposes of this Certificate and the accompanying Tender, I/we understand that the word "competitor" shall include any individual or organisation, other than the Tenderer, whether or not affiliated with the Tenderer, who:
 - a) has been requested to submit a Tender in response to this Tender invitation;
 - b) could potentially submit a Tender in response to this Tender invitation, based on their qualifications, abilities or experience; and
 - c) provides the same Services as the Tenderer and/or is in the same line of business as the Tenderer
5. The Tenderer has arrived at the accompanying Tender independently from, and without consultation, communication, agreement or arrangement with any competitor. However communication between partners in a joint venture or consortium will not be construed as collusive Tendering.
6. In particular, without limiting the generality of paragraph 5 above, there has been no consultation, communication, agreement or arrangement with any competitor regarding:



- a) prices;
 - b) geographical area where Services will be rendered [market allocation]
 - c) methods, factors or formulas used to calculate prices;
 - d) the intention or decision to submit or not to submit, a Tender;
 - e) the submission of a tender which does not meet the specifications and conditions of the tender; or
 - f) Tendering with the intention not winning the tender.
7. In addition, there have been no consultations, communications, agreements or arrangements with any competitor regarding the quality, quantity, specifications and conditions or delivery particulars of the Services to which this tender relates.
8. The terms of the accompanying tender have not been, and will not be, disclosed by the Tenderer, directly or indirectly, to any competitor, prior to the date and time of the official tender opening or of the awarding of the contract.
9. I/We am/are aware that, in addition and without prejudice to any other remedy provided to combat any restrictive practices related to tenders and contracts, tenders that are suspicious will be reported to the Competition Commission for investigation and possible imposition of administrative penalties in terms of section 59 of the Competition Act No 89 of 1998 and/or may be reported to the National Prosecuting Authority [NPA] for criminal investigation. In addition, Tenderers that submit suspicious tenders may be restricted from conducting business with the public sector for a period not exceeding 10 [ten] years in terms of the Prevention and Combating of Corrupt Activities Act No 12 of 2004 or any other applicable legislation.

Signed on this _____ day of _____ 20____

SIGNATURE OF TENDERER



TRANSNET PORT TERMINALS

TENDER NUMBER: TPT/2024/03/0066/60631/RFP

DESCRIPTION OF THE SERVICES: FOR THE SUPPLY OF SERVICES TO REFURBISH STACKER RECLAIMER 3 AT THE SALDANHA IRON ORE TERMINAL FOR TRANSNET SOC LTD (REG.NO.1990/000900/30) OPERATING AS TRANSNET PORT TERMINALS, (HEREINAFTER REFERRED TO AS "TPT"), AS A ONCE OFF SUPPLY.

T2.2-20 Service Provider Integrity Pact

Important Note: All potential tenderers must read this document and certify in the RFP Declaration Form that that have acquainted themselves with, and agree with the content.

The contract with the successful tenderer will automatically incorporate this Integrity Pact and shall be deemed as part of the final concluded contract.

INTEGRITY PACT

Between

TRANSNET SOC LTD

Registration Number: 1990/000900/30

("Transnet")

and

The Contractor (hereinafter referred to as the "Tenderer/Service Providers/Contractor")

TRANSNET PORT TERMINALS

TENDER NUMBER: TPT/2024/03/0066/60631/RFP

DESCRIPTION OF THE SERVICES: FOR THE SUPPLY OF SERVICES TO REFURBISH STACKER RECLAIMER 3 AT THE SALDANHA IRON ORE TERMINAL FOR TRANSNET SOC LTD (REG.NO.1990/000900/30) OPERATING AS TRANSNET PORT TERMINALS, (HEREINAFTER REFERRED TO AS "TPT"), AS A ONCE OFF SUPPLY.

PREAMBLE

Transnet values full compliance with all relevant laws and regulations, ethical standards and the principles of economical use of resources, fairness and transparency in its relations with its Tenderers/Service Providers/Contractors.

In order to achieve these goals, Transnet and the Tenderer/Service Provider/Contractor hereby enter into this agreement hereinafter referred to as the "Integrity Pact" which will form part of the Tenderer's/Service Provider's/Contractor's application for registration with Transnet as a vendor.

The general purpose of this Integrity Pact is to agree on avoiding all forms of dishonesty, fraud and corruption by following a system that is fair, transparent and free from any undue influence prior to, during and subsequent to the currency of any procurement and/or reverse logistics event and any further contract to be entered into between the Parties, relating to such event.

All Tenderers/Service Providers/Contractor's will be required to sign and comply with undertakings contained in this Integrity Pact, should they want to be registered as a Transnet vendor.

1 OBJECTIVES

- 1.1 Transnet and the Tenderer/Service Provider/Contractor agree to enter into this Integrity Pact, to avoid all forms of dishonesty, fraud and corruption including practices that are anti-competitive in nature, negotiations made in bad faith and under-pricing by following a system that is fair, transparent and free from any influence/unprejudiced dealings prior to, during and subsequent to the currency of the contract to be entered into with a view to:
 - a) Enable Transnet to obtain the desired contract at a reasonable and competitive price in conformity to the defined specifications of the works, goods and services; and
 - b) Enable Tenderers/Service Providers/Contractors to abstain from bribing or participating in any corrupt practice in order to secure the contract.

2 COMMITMENTS OF TRANSNET

Transnet commits to take all measures necessary to prevent dishonesty, fraud and corruption and to observe the following principles:

- 2.1 Transnet hereby undertakes that no employee of Transnet connected directly or indirectly with the sourcing event and ensuing contract, will demand, take a promise for or accept directly or through intermediaries any bribe, consideration, gift, reward, favour or any material or immaterial benefit or any other advantage

TRANSNET PORT TERMINALS

TENDER NUMBER: TPT/2024/03/0066/60631/RFP

DESCRIPTION OF THE SERVICES: FOR THE SUPPLY OF SERVICES TO REFURBISH STACKER RECLAIMER 3 AT THE SALDANHA IRON ORE TERMINAL FOR TRANSNET SOC LTD (REG.NO.1990/000900/30) OPERATING AS TRANSNET PORT TERMINALS, (HEREINAFTER REFERRED TO AS "TPT"), AS A ONCE OFF SUPPLY.

from the Tenderer, either for themselves or for any person, organisation or third party related to the contract in exchange for an advantage in the tendering process, Tender evaluation, contracting or implementation process related to any contract.

- 2.2 Transnet will, during the registration and tendering process treat all Tenderers/ Service Providers/Contractor with equity, transparency and fairness. Transnet will in particular, before and during the registration process, provide to all Tenderers/ Service Providers/Contractors the same information and will not provide to any Tenderers/Service Providers/Contractors confidential/additional information through which the Tenderers/Service Providers/Contractors could obtain an advantage in relation to any tendering process.
- 2.3 Transnet further confirms that its employees will not favour any prospective Tenderers/Service Providers/Contractors in any form that could afford an undue advantage to a particular Tenderer during the tendering stage, and will further treat all Tenderers/Service Providers/Contractors participating in the tendering process in a fair manner.
- 2.4 Transnet will exclude from the tender process such employees who have any personal interest in the Tenderers/Service Providers/Contractors participating in the tendering process.

3 OBLIGATIONS OF THE TENDERER / SERVICE PROVIDER

- 3.1 Transnet has a '**Zero Gifts**' Policy. No employee is allowed to accept gifts, favours or benefits.
 - a) Transnet officials and employees **shall not** solicit, give or accept, or from agreeing to solicit, give, accept or receive directly or indirectly, any gift, gratuity, favour, entertainment, loan, or anything of monetary value, from any person or juridical entities in the course of official duties or in connection with any operation being managed by, or any transaction which may be affected by the functions of their office.
 - b) Transnet officials and employees **shall not** solicit or accept gifts of any kind, from vendors, suppliers, customers, potential employees, potential vendors, and suppliers, or any other individual or organisation irrespective of the value.
 - c) Under **no circumstances** should gifts, business courtesies or hospitality packages be accepted from or given to prospective suppliers participating in a tender process at the respective employee's Operating Division, regardless of retail value.

TRANSNET PORT TERMINALS

TENDER NUMBER: TPT/2024/03/0066/60631/RFP

DESCRIPTION OF THE SERVICES: FOR THE SUPPLY OF SERVICES TO REFURBISH STACKER RECLAIMER 3 AT THE SALDANHA IRON ORE TERMINAL FOR TRANSNET SOC LTD (REG.NO.1990/000900/30) OPERATING AS TRANSNET PORT TERMINALS, (HEREINAFTER REFERRED TO AS "TPT"), AS A ONCE OFF SUPPLY.

- d) Gratuities, bribes or kickbacks of any kind must never be solicited, accepted or offered, either directly or indirectly. This includes money, loans, equity, special privileges, personal favours, benefit or services. Such favours will be considered to constitute corruption.

3.2 The Tenderer/Service Provider/Contractor commits itself to take all measures necessary to prevent corrupt practices, unfair means and illegal activities during any stage of its Tender or during any ensuing contract stage in order to secure the contract or in furtherance to secure it and in particular the Tenderer/Service Provider/Contractor commits to the following:

- a) The Tenderer/Service Provider/Contractor will not, directly or through any other person or firm, offer, promise or give to Transnet or to any of Transnet's employees involved in the tendering process or to any third person any material or other benefit or payment, in order to obtain in exchange an advantage during the tendering process; and
- b) The Tenderer/Service Provider/Contractor will not offer, directly or through intermediaries, any bribe, gift, consideration, reward, favour, any material or immaterial benefit or other advantage, commission, fees, brokerage or inducement to any employee of Transnet, connected directly or indirectly with the tendering process, or to any person, organisation or third party related to the contract in exchange for any advantage in the tendering, evaluation, contracting and implementation of the contract.

3.3 The Tenderer/Service Provider/Contractor will not collude with other parties interested in the contract to preclude a competitive Tender price, impair the transparency, fairness and progress of the tendering process, Tender evaluation, contracting and implementation of the contract. The Tenderer / Service Provider further commits itself to delivering against all agreed upon conditions as stipulated within the contract.

3.4 The Tenderer/Service Provider/Contractor will not enter into any illegal or dishonest agreement or understanding, whether formal or informal with other Tenderers/Service Providers/Contractors. This applies in particular to certifications, submissions or non-submission of documents or actions that are restrictive or to introduce cartels into the tendering process.

3.5 The Tenderer/Service Provider/Contractor will not commit any criminal offence under the relevant anti-corruption laws of South Africa or any other country. Furthermore, the Tenderer/Service Provider/Contractor will not use for illegitimate purposes or for restrictive purposes or personal gain, or pass on to others, any information provided by Transnet as part of the business relationship,

TRANSNET PORT TERMINALS

TENDER NUMBER: TPT/2024/03/0066/60631/RFP

DESCRIPTION OF THE SERVICES: FOR THE SUPPLY OF SERVICES TO REFURBISH STACKER RECLAIMER 3 AT THE SALDANHA IRON ORE TERMINAL FOR TRANSNET SOC LTD (REG.NO.1990/000900/30) OPERATING AS TRANSNET PORT TERMINALS, (HEREINAFTER REFERRED TO AS "TPT"), AS A ONCE OFF SUPPLY.

regarding plans, technical proposals and business details, including information contained or transmitted electronically.

- 3.6 A Tenderer/Service Provider/Contractor of foreign origin shall disclose the name and address of its agents or representatives in South Africa, if any, involved directly or indirectly in the registration or tendering process. Similarly, the Tenderer / Service Provider / Contractor of South African nationality shall furnish the name and address of the foreign principals, if any, involved directly or indirectly in the registration or tendering process.
- 3.7 The Tenderer/Service Provider/Contractor will not misrepresent facts or furnish false or forged documents or information in order to influence the tendering process to the advantage of the Tenderer/Service Provider/Contractor or detriment of Transnet or other competitors.
- 3.8 Transnet may require the Tenderer/Service Provider/Contractor to furnish Transnet with a copy of its code of conduct. Such code of conduct must address the compliance programme for the implementation of the code of conduct and reject the use of bribes and other dishonest and unethical conduct.
- 3.9 The Tenderer/Service Provider/Contractor will not instigate third persons to commit offences outlined above or be an accessory to such offences.
- 3.10 The Tenderer/Service Provider/Contractor confirms that they will uphold the ten principles of the United Nations Global Compact (UNGC) in the fields of Human Rights, Labour, Anti-Corruption and the Environment when undertaking business with Transnet as follows:
 - a) Human Rights
 - Principle 1: Businesses should support and respect the protection of internationally proclaimed human rights; and
 - Principle 2: make sure that they are not complicit in human rights abuses.
 - b) Labour
 - Principle 3: Businesses should uphold the freedom of association and the effective recognition of the right to collective bargaining;
 - Principle 4: the elimination of all forms of forced and compulsory labour;
 - Principle 5: the effective abolition of child labour; and

TRANSNET PORT TERMINALS

TENDER NUMBER: TPT/2024/03/0066/60631/RFP

DESCRIPTION OF THE SERVICES: FOR THE SUPPLY OF SERVICES TO REFURBISH STACKER RECLAIMER 3 AT THE SALDANHA IRON ORE TERMINAL FOR TRANSNET SOC LTD (REG.NO.1990/000900/30) OPERATING AS TRANSNET PORT TERMINALS, (HEREINAFTER REFERRED TO AS "TPT"), AS A ONCE OFF SUPPLY.

- Principle 6: the elimination of discrimination in respect of employment and occupation.

c) Environment

- Principle 7: Businesses should support a precautionary approach to environmental challenges;
- Principle 8: undertake initiatives to promote greater environmental responsibility; and
- Principle 9: encourage the development and diffusion of environmentally friendly technologies.

d) Anti-Corruption

- Principle 10: Businesses should work against corruption in all its forms, including extortion and bribery.

4 INDEPENDENT TENDERING

4.1 For the purposes of that Certificate in relation to any submitted Tender, the Tenderer declares to fully understand that the word "competitor" shall include any individual or organisation, other than the Tenderer, whether or not affiliated with the Tenderer, who:

- a) has been requested to submit a Tender in response to this Tender invitation;
- b) could potentially submit a Tender in response to this Tender invitation, based on their qualifications, abilities or experience; and
- c) provides the same Goods and Services as the Tenderer and/or is in the same line of business as the Tenderer.

4.2 The Tenderer has arrived at his submitted Tender independently from, and without consultation, communication, agreement or arrangement with any competitor. However communication between partners in a joint venture or consortium will not be construed as collusive tendering.

4.3 In particular, without limiting the generality of paragraph 5 above, there has been no consultation, communication, agreement or arrangement with any competitor regarding:

- a) prices;
- b) geographical area where Goods or Services will be rendered [market allocation];
- c) methods, factors or formulas used to calculate prices;

TRANSNET PORT TERMINALS

TENDER NUMBER: TPT/2024/03/0066/60631/RFP

DESCRIPTION OF THE SERVICES: FOR THE SUPPLY OF SERVICES TO REFURBISH STACKER RECLAIMER 3 AT THE SALDANHA IRON ORE TERMINAL FOR TRANSNET SOC LTD (REG.NO.1990/000900/30) OPERATING AS TRANSNET PORT TERMINALS, (HEREINAFTER REFERRED TO AS "TPT"), AS A ONCE OFF SUPPLY.

- d) the intention or decision to submit or not to submit, a Tender;
 - e) the submission of a Tender which does not meet the specifications and conditions of the RFP; or
 - f) tendering with the intention of not winning the Tender.
- 4.4 In addition, there have been no consultations, communications, agreements or arrangements with any competitor regarding the quality, quantity, specifications and conditions or delivery particulars of the Goods or Services to which his/her tender relates.
- 4.5 The terms of the Tender as submitted have not been, and will not be, disclosed by the Tenderer, directly or indirectly, to any competitor, prior to the date and time of the official Tender opening or of the awarding of the contract.
- 4.6 Tenderers are aware that, in addition and without prejudice to any other remedy provided to combat any restrictive practices related to Tenders and contracts, Tenders that are suspicious will be reported to the Competition Commission for investigation and possible imposition of administrative penalties in terms of section 59 of the Competition Act No 89 of 1998 and/or may be reported to the National Prosecuting Authority [**NPA**] for criminal investigation and/or may be restricted from conducting business with the public sector for a period not exceeding 10 [ten] years in terms of the Prevention and Combating of Corrupt Activities Act No 12 of 2004 or any other applicable legislation.
- 4.7 Should the Tenderer find any terms or conditions stipulated in any of the relevant documents quoted in the Tender unacceptable, it should indicate which conditions are unacceptable and offer alternatives by written submission on its company letterhead, attached to its submitted Tender. Any such submission shall be subject to review by Transnet's Legal Counsel who shall determine whether the proposed alternative(s) are acceptable or otherwise, as the case may be.

5 DISQUALIFICATION FROM TENDERING PROCESS

- 5.1 If the Tenderer/Service Provider/Contractor has committed a transgression through a violation of section 3 of this Integrity Pact or in any other form such as to put its reliability or credibility as a Tenderer/Service Provider/Contractor into question, Transnet may reject the Tenderer's / Service Provider's / Contractor's application from the registration or tendering process and remove the Tenderer/Service Provider/Contractor from its database, if already registered.

TRANSNET PORT TERMINALS

TENDER NUMBER: TPT/2024/03/0066/60631/RFP

DESCRIPTION OF THE SERVICES: FOR THE SUPPLY OF SERVICES TO REFURBISH STACKER RECLAIMER 3 AT THE SALDANHA IRON ORE TERMINAL FOR TRANSNET SOC LTD (REG.NO.1990/000900/30) OPERATING AS TRANSNET PORT TERMINALS, (HEREINAFTER REFERRED TO AS "TPT"), AS A ONCE OFF SUPPLY.

- 5.2 If the Tenderer/Service Provider/Contractor has committed a transgression through a violation of section 3, or any material violation, such as to put its reliability or credibility into question. Transnet may after following due procedures and at its own discretion also exclude the Tenderer/Service Provider /Contractor from future tendering processes. The imposition and duration of the exclusion will be determined by the severity of the transgression. The severity will be determined by the circumstances of the case, which will include amongst others the number of transgressions, the position of the transgressors within the company hierarchy of the Tenderer/Service Provider/Contractor and the amount of the damage. The exclusion will be imposed for up to a maximum of 10 (ten) years. However, Transnet reserves the right to impose a longer period of exclusion, depending on the gravity of the misconduct.
- 5.3 If the Tenderer/Service Provider/Contractor can prove that it has restored the damage caused by it and has installed a suitable corruption prevention system, or taken other remedial measures as the circumstances of the case may require, Transnet may at its own discretion revoke the exclusion or suspend the imposed penalty.

6 TRANSNET'S LIST OF EXCLUDED TENDERERS (BLACKLIST)

- 6.1 The process of restriction is used to exclude a company/person from conducting future business with Transnet and other organs of state for a specified period. No Tender shall be awarded to a Tenderer whose name (or any of its members, directors, partners or trustees) appear on the Register of Tender Defaulters kept by National Treasury, or who have been placed on National Treasury's List of Restricted Suppliers. Transnet reserves the right to withdraw an award, or cancel a contract concluded with a Tenderer should it be established, at any time, that a tenderer has been restricted with National Treasury by another government institution.
- 6.2 All the stipulations on Transnet's restriction process as laid down in Transnet's Supply Chain Policy and Procurement Procedures Manual (CPM included) are included herein by way of reference. Below follows a condensed summary of this restriction procedure.
- 6.3 On completion of the restriction procedure, Transnet will submit the restricted entity's details (including the identity number of the individuals and registration number of the entity) to National Treasury for placement on National Treasury's Database of Restricted Suppliers for the specified period of exclusion. National Treasury will make the final decision on whether to restrict an entity from doing business with any organ of state for a period not exceeding 10 years and place

TRANSNET PORT TERMINALS

TENDER NUMBER: TPT/2024/03/0066/60631/RFP

DESCRIPTION OF THE SERVICES: FOR THE SUPPLY OF SERVICES TO REFURBISH STACKER RECLAIMER 3 AT THE SALDANHA IRON ORE TERMINAL FOR TRANSNET SOC LTD (REG.NO.1990/000900/30) OPERATING AS TRANSNET PORT TERMINALS, (HEREINAFTER REFERRED TO AS "TPT"), AS A ONCE OFF SUPPLY.

the entity concerned on the Database of Restricted Suppliers published on its official website.

- 6.4 The decision to restrict is based on one of the grounds for restriction. The standard of proof to commence the restriction process is whether a "*prima facie*" (i.e. on the face of it) case has been established.
- 6.5 Depending on the seriousness of the misconduct and the strategic importance of the Goods/Services, in addition to restricting a company/person from future business, Transnet may decide to terminate some or all existing contracts with the company/person as well.
- 6.6 A Service Provider or Contractor to Transnet may not subcontract any portion of the contract to a blacklisted company.
- 6.7 Grounds for blacklisting include: If any person/Enterprise which has submitted a Tender, concluded a contract, or, in the capacity of agent or subcontractor, has been associated with such Tender or contract:
 - a) Has, in bad faith, withdrawn such Tender after the advertised closing date and time for the receipt of Tenders;
 - b) has, after being notified of the acceptance of his Tender, failed or refused to sign a contract when called upon to do so in terms of any condition forming part of the Tender documents;
 - c) has carried out any contract resulting from such Tender in an unsatisfactory manner or has breached any condition of the contract;
 - d) has offered, promised or given a bribe in relation to the obtaining or execution of the contract;
 - e) has acted in a fraudulent or improper manner or in bad faith towards Transnet or any Government Department or towards any public body, Enterprise or person;
 - f) has made any incorrect statement in a certificate or other communication with regard to the Local Content of his Goods or his B-BBEE status and is unable to prove to the satisfaction of Transnet that:
 - (i) he made the statement in good faith honestly believing it to be correct;
 - and

TRANSNET PORT TERMINALS

TENDER NUMBER: TPT/2024/03/0066/60631/RFP

DESCRIPTION OF THE SERVICES: FOR THE SUPPLY OF SERVICES TO REFURBISH STACKER RECLAIMER 3 AT THE SALDANHA IRON ORE TERMINAL FOR TRANSNET SOC LTD (REG.NO.1990/000900/30) OPERATING AS TRANSNET PORT TERMINALS, (HEREINAFTER REFERRED TO AS "TPT"), AS A ONCE OFF SUPPLY.

- (ii) before making such statement he took all reasonable steps to satisfy himself of its correctness;
 - g) caused Transnet damage, or to incur costs in order to meet the contractor's requirements and which could not be recovered from the contractor;
 - h) has litigated against Transnet in bad faith.
- 6.8 Grounds for blacklisting include a company/person recorded as being a company or person prohibited from doing business with the public sector on National Treasury's database of Restricted Service Providers or Register of Tender Defaulters.
- 6.9 Companies associated with the person/s guilty of misconduct (i.e. entities owned, controlled or managed by such persons), any companies subsequently formed by the person(s) guilty of the misconduct and/or an existing company where such person(s) acquires a controlling stake may be considered for blacklisting. The decision to extend the blacklist to associated companies will be at the sole discretion of Transnet.

7 PREVIOUS TRANSGRESSIONS

- 7.1 The Tenderer/Service Provider/Contractor hereby declares that no previous transgressions resulting in a serious breach of any law, including but not limited to, corruption, fraud, theft, extortion and contraventions of the Competition Act 89 of 1998, which occurred in the last 5 (five) years with any other public sector undertaking, government department or private sector company that could justify its exclusion from its registration on the Tenderer's/Service Provider's/Contractor's database or any tendering process.
- 7.2 If it is found to be that the Tenderer/Service Provider/Contractor made an incorrect statement on this subject, the Tenderer/Service Provider/Contractor can be rejected from the registration process or removed from the Tenderer/Service Provider/Contractor database, if already registered, for such reason (refer to the Breach of Law Returnable Form contained in the document.)

8 SANCTIONS FOR VIOLATIONS

- 8.1 Transnet shall also take all or any one of the following actions, wherever required to:
- a) Immediately exclude the Tenderer/Service Provider/Contractor from the tendering process or call off the pre-contract negotiations without giving any compensation

TRANSNET PORT TERMINALS

TENDER NUMBER: TPT/2024/03/0066/60631/RFP

DESCRIPTION OF THE SERVICES: FOR THE SUPPLY OF SERVICES TO REFURBISH STACKER RECLAIMER 3 AT THE SALDANHA IRON ORE TERMINAL FOR TRANSNET SOC LTD (REG.NO.1990/000900/30) OPERATING AS TRANSNET PORT TERMINALS, (HEREINAFTER REFERRED TO AS "TPT"), AS A ONCE OFF SUPPLY.

- the Tenderer/Service Provider/Contractor. However, the proceedings with the other Tenderer/ Service Provider/Contractor may continue;
- b) Immediately cancel the contract, if already awarded or signed, without giving any compensation to the Tenderer/Service Provider/Contractor;
 - c) Recover all sums already paid by Transnet;
 - d) Encash the advance bank guarantee and performance bond or warranty bond, if furnished by the Tenderer/Service Provider/Contractor, in order to recover the payments, already made by Transnet, along with interest;
 - e) Cancel all or any other contracts with the Tenderer/Service Provider/Contractor; and
 - f) Exclude the Tenderer/ Service Provider/Contractor from entering into any Tender with Transnet in future.

9 CONFLICTS OF INTEREST

9.1 A conflict of interest includes, inter alia, a situation in which:

- a) A Transnet employee has a personal financial interest in a tendering / supplying entity; and
- b) A Transnet employee has private interests or personal considerations or has an affiliation or a relationship which affects, or may affect, or may be perceived to affect his / her judgment in action in the best interest of Transnet, or could affect the employee's motivations for acting in a particular manner, or which could result in, or be perceived as favouritism or nepotism.

9.2 A Transnet employee uses his / her position, or privileges or information obtained while acting in the capacity as an employee for:

- a) Private gain or advancement; or
- b) The expectation of private gain, or advancement, or any other advantage accruing to the employee must be declared in a prescribed form.

Thus, conflicts of interest of any Tender committee member or any person involved in the sourcing process must be declared in a prescribed form.

9.3 If a Tenderer/Service Provider/Contractor has or becomes aware of a conflict of interest i.e. a family, business and / or social relationship between its owner(s)/ member(s)/director(s)/partner(s)/shareholder(s) and a Transnet employee/ member of Transnet's Board of Directors in respect of a Tender which will be considered for the Tender process, the Tenderer/Service Provider/ Contractor:

- a) must disclose the interest and its general nature, in the Request for Proposal ("RFX") declaration form; or
- b) must notify Transnet immediately in writing once the circumstances has arisen.

9.4 The Tenderer/Service Provider/Contractor shall not lend to or borrow any money from or enter into any monetary dealings or transactions, directly or indirectly,

TRANSNET PORT TERMINALS

TENDER NUMBER: TPT/2024/03/0066/60631/RFP

DESCRIPTION OF THE SERVICES: FOR THE SUPPLY OF SERVICES TO REFURBISH STACKER RECLAIMER 3 AT THE SALDANHA IRON ORE TERMINAL FOR TRANSNET SOC LTD (REG.NO.1990/000900/30) OPERATING AS TRANSNET PORT TERMINALS, (HEREINAFTER REFERRED TO AS "TPT"), AS A ONCE OFF SUPPLY.

with any committee member or any person involved in the sourcing process, where this is done, Transnet shall be entitled forthwith to rescind the contract and all other contracts with the Tenderer/Service Provider/Contractor.

10 DISPUTE RESOLUTION

10.1 Transnet recognises that trust and good faith are pivotal to its relationship with its Tenderer / Service Provider / Contractor. When a dispute arises between Transnet and its Tenderer / Service Provider / Contractor, the parties should use their best endeavours to resolve the dispute in an amicable manner, whenever possible. Litigation in bad faith negates the principles of trust and good faith on which commercial relationships are based. Accordingly, following a blacklisting process as mentioned in paragraph 6 above, Transnet will not do business with a company that litigates against it in bad faith or is involved in any action that reflects bad faith on its part. Litigation in bad faith includes, but is not limited to the following instances:

- a) **Vexatious proceedings:** these are frivolous proceedings which have been instituted without proper grounds;
- b) **Perjury:** where a Tenderer / Service Provider / Contractor make a false statement either in giving evidence or on an affidavit;
- c) **Scurrilous allegations:** where a Tenderer / Service Provider / Contractor makes allegations regarding a senior Transnet employee which are without proper foundation, scandalous, abusive or defamatory; and
- d) **Abuse of court process:** when a Tenderer / Service Provider / Contractor abuses the court process in order to gain a competitive advantage during a Tender process.

11 GENERAL

11.1 This Integrity Pact is governed by and interpreted in accordance with the laws of the Republic of South Africa.

11.2 The actions stipulated in this Integrity Pact are without prejudice to any other legal action that may follow in accordance with the provisions of the law relating to any civil or criminal proceedings.

11.3 The validity of this Integrity Pact shall cover all the tendering processes and will be valid for an indefinite period unless cancelled by either Party.

11.4 Should one or several provisions of this Integrity Pact turn out to be invalid the remainder of this Integrity Pact remains valid.



TRANSNET PORT TERMINALS

TENDER NUMBER: TPT/2024/03/0066/60631/RFP

DESCRIPTION OF THE SERVICES: FOR THE SUPPLY OF SERVICES TO REFURBISH STACKER RECLAIMER 3 AT THE SALDANHA IRON ORE TERMINAL FOR TRANSNET SOC LTD (REG.NO.1990/000900/30) OPERATING AS TRANSNET PORT TERMINALS, (HEREINAFTER REFERRED TO AS "TPT"), AS A ONCE OFF SUPPLY.

11.5 Should a Tenderer/Service Provider/Contractor be confronted with dishonest, fraudulent or corruptive behaviour of one or more Transnet employees, Transnet expects its Tenderer/Service Provider/Contractor to report this behaviour directly to a senior Transnet official/employee or alternatively by using Transnet's "Tip-Off Anonymous" hotline number 0800 003 056, whereby your confidentiality is guaranteed.

The Parties hereby declare that each of them has read and understood the clauses of this Integrity Pact and shall abide by it. To the best of the Parties' knowledge and belief, the information provided in this Integrity Pact is true and correct.

I duly authorised by the tendering entity, hereby certify that the tendering entity are **fully acquainted** with the contents of the Integrity Pact and further **agree to abide by it** in full.

Signature

Date

TRANSNET PORT TERMINALS

TENDER NUMBER: TPT/2024/03/0066/60631/RFP

DESCRIPTION OF THE SERVICES: FOR THE SUPPLY OF SERVICES TO REFURBISH STACKER RECLAIMER 3 AT THE SALDANHA IRON ORE TERMINAL FOR TRANSNET SOC LTD (REG.NO.1990/000900/30) OPERATING AS TRANSNET PORT TERMINALS, (HEREINAFTER REFERRED TO AS "TPT"), AS A ONCE OFF SUPPLY.

T2.2-21 : Supplier Code of Conduct

Transnet SOC Limited aims to achieve the best value for money when buying or selling goods and obtaining services. This however must be done in an open and fair manner that supports and drives a competitive economy. Underpinning our process are several acts and policies that any supplier dealing with Transnet must understand and support. These are:

- The Transnet Procurement Policy – A guide for Tenderers.
- Section 217 of the Constitution - the five pillars of Public PSCM (Procurement and Supply Chain Management): fair, equitable, transparent, competitive and cost effective;
- The Public Finance Management Act (PFMA);
- The Broad Based Black Economic Empowerment Act (BBBEE)
- The Prevention and Combating of Corrupt Activities Act (PRECCA); and
- The Construction Industry Development Board Act (CIDB Act).

This code of conduct has been included in this contract to formally appraise Transnet Suppliers of Transnet's expectations regarding behaviour and conduct of its Suppliers.

Prohibition of Bribes, Kickbacks, Unlawful Payments, and Other Corrupt Practices

Transnet is in the process of transforming itself into a self-sustaining State Owned Enterprise, actively competing in the logistics industry. Our aim is to become a world class, profitable, logistics organisation. As such, our transformation is focused on adopting a performance culture and to adopt behaviours that will enable this transformation.

1. Transnet SOC Limited will not participate in corrupt practices. Therefore, it expects its suppliers to act in a similar manner.

- Transnet and its employees will follow the laws of this country and keep accurate business records that reflect actual transactions with, and payments to, our suppliers.
- Employees must not accept or request money or anything of value, directly or indirectly, from suppliers.
- Employees may not receive anything that is calculated to:

TRANSNET PORT TERMINALS

TENDER NUMBER: TPT/2024/03/0066/60631/RFP

DESCRIPTION OF THE SERVICES: FOR THE SUPPLY OF SERVICES TO REFURBISH STACKER RECLAIMER 3 AT THE SALDANHA IRON ORE TERMINAL FOR TRANSNET SOC LTD (REG.NO.1990/000900/30) OPERATING AS TRANSNET PORT TERMINALS, (HEREINAFTER REFERRED TO AS "TPT"), AS A ONCE OFF SUPPLY.

- Illegally influence their judgement or conduct or to ensure the desired outcome of a sourcing activity;
- Win or retain business or to influence any act or decision of any person involved in sourcing decisions; or
- Gain an improper advantage.
- There may be times when a supplier is confronted with fraudulent or corrupt behaviour of Transnet employees. We expect our Suppliers to use our "Tip-offs Anonymous" Hot line to report these acts. (0800 003 056).

2. *Transnet SOC Limited is firmly committed to the ideas of free and competitive enterprise.*

- Suppliers are expected to comply with all applicable laws and regulations regarding fair competition and antitrust practices.
- Transnet does not engage with non-value adding agents or representatives solely for the purpose of increasing BBBEE spend (fronting).

3. *Transnet's relationship with suppliers requires us to clearly define requirements, to exchange information and share mutual benefits.*

- Generally, suppliers have their own business standards and regulations. Although Transnet cannot control the actions of our suppliers, we will not tolerate any illegal activities. These include, but are not limited to:
 - Misrepresentation of their product (origin of manufacture, specifications, intellectual property rights, etc);
 - Collusion;
 - Failure to disclose accurate information required during the sourcing activity (ownership, financial situation, BBBEE status, etc.);
 - Corrupt activities listed above; and
 - Harassment, intimidation or other aggressive actions towards Transnet employees.



TRANSNET PORT TERMINALS

TENDER NUMBER: TPT/2024/03/0066/60631/RFP

DESCRIPTION OF THE SERVICES: FOR THE SUPPLY OF SERVICES TO REFURBISH STACKER RECLAIMER 3 AT THE SALDANHA IRON ORE TERMINAL FOR TRANSNET SOC LTD (REG.NO.1990/000900/30) OPERATING AS TRANSNET PORT TERMINALS, (HEREINAFTER REFERRED TO AS "TPT"), AS A ONCE OFF SUPPLY.

- Suppliers must be evaluated and approved before any materials, components, products or services are purchased from them. Rigorous due diligence is conducted and the supplier is expected to participate in an honest and straight forward manner.
- Suppliers must record and report facts accurately, honestly and objectively. Financial records must be accurate in all material respects.



TRANSNET PORT TERMINALS

TENDER NUMBER: TPT/2024/03/0066/60631/RFP

DESCRIPTION OF THE SERVICES: FOR THE SUPPLY OF SERVICES TO REFURBISH STACKER RECLAIMER 3 AT THE SALDANHA IRON ORE TERMINAL FOR TRANSNET SOC LTD (REG.NO.1990/000900/30) OPERATING AS TRANSNET PORT TERMINALS, (HEREINAFTER REFERRED TO AS "TPT"), AS A ONCE OFF SUPPLY.

Conflicts of Interest

A conflict of interest arises when personal interests or activities influence (or appear to influence) the ability to act in the best interests of Transnet SOC Limited.

- Doing business with family members.
- Having a financial interest in another company in our industry

Where possible, contracts will be negotiated to include the above in the terms of such contracts. To the extent such terms are not included in contractual obligations and any of the above code is breached, then Transnet reserves its right to review doing business with these suppliers.

I, _____ of _____
(insert name of Director or as per Authority Resolution from Board of Directors) *(insert name of Company)*

hereby acknowledge having read, understood and agree to the terms and conditions set out in the "Transnet Supplier Code of Conduct."

Signed this on day _____ at _____

Signature

T2.2-22 Agreement in terms of Protection of Personal Information Act, 4 of 2013 ("POPIA")

1. PREAMBLE AND INTRODUCTION

- 1.1. The rights and obligation of the Parties in terms of the Protection of Personal Information Act, 4 of 2013 ("POPIA") are included as forming part of the terms and conditions of this contract.

2. PROTECTION OF PERSONAL INFORMATION

- 2.1. The following terms shall bear the same meaning as contemplated in Section 1 of the Protection of Person information act, No. of 2013 "(POPIA)":
consent; data subject; electronic communication; information officer; operator; person; personal information; processing; record; Regulator; responsible party; special information; as well as any terms derived from these terms.
- 2.2. The Operator will process all information by the Transnet in terms of the requirements contemplated in Section 4(1) of the POPIA:
Accountability; Processing limitation; Purpose specification; Further processing limitation; Information quality; Openness; Security safeguards and Data subject participation.
- 2.3. The Parties acknowledge and agree that, in relation to personal information of Transnet and the information of a third party that will be processed pursuant to this Agreement , the Operator is (..... insert name of Tenderer/Contractor) hereinafter Operator and the Data subject is "Transnet". Operator will process personal information only with the knowledge and authorisation of Transnet and will treat personal information and the information of a third party which comes to its knowledge as confidential and will not disclose it, unless so required by law or subject to the exceptions contained in the POPIA.
- 2.4. Transnet reserves all the rights afforded to it by the POPIA in the processing of any of its information as contained in this Agreement and the Operator is required to comply with all prescripts as detailed in the POPIA relating to all information concerning Transnet.
- 2.5. In terms of this Agreement, the Operator acknowledges that it will obtain and have access to personal information of Transnet and the information of a third party and agrees that it shall only process the information disclosed by Transnet in terms of this Agreement and only for the purposes as detailed in this Agreement and in accordance with any applicable law.
- 2.6. Should there be a need for the Operator to process the personal information and the information of a third party in a way that is not agreed to in this Agreement, the Operator must request consent

from Transnet to the processing of its personal information or and the information of a third party in a manner other than that it was collected for, which consent cannot be unreasonably withheld.

- 2.7. Furthermore, the Operator will not otherwise modify, amend or alter any personal information and the information of a third party submitted by Transnet or disclose or permit the disclosure of any personal information and the information of a third party to any third party without prior written consent from Transnet.
- 2.8. The Operator shall, at all times, ensure compliance with any applicable laws put in place and maintain sufficient measures, policies and systems to manage and secure against all forms of risks to any information that may be shared or accessed pursuant to the services offered to Transnet in terms of this Agreement (physically, through a computer or any other form of electronic communication).
- 2.9. The Operator shall notify Transnet in writing of any unauthorised access to personal information and the information of a third party , cybercrimes or suspected cybercrimes, in its knowledge and report such crimes or suspected crimes to the relevant authorities in accordance with applicable laws, after becoming aware of such crimes or suspected crime. The Operator must inform Transnet of the breach as soon as it has occurred to allow Transnet to take all necessary remedial steps to mitigate the extent of the loss or compromise of personal information and the information of a third party and to restore the integrity of the affected personal information as quickly as is possible.
- 2.10. Transnet may, in writing, request the Operator to confirm and/or make available any personal information and the information of a third party in its possession in relation to Transnet and if such personal information has been accessed by third parties and the identity thereof in terms of the POPIA.
- 2.11. Transnet may further request that the Operator correct, delete, destroy, withdraw consent or object to the processing of any personal information and the information of a third party relating to the Transnet or a third party in the Operator's s possession in terms of the provision of the POPIA and utilizing Form 2 of the POPIA Regulations .
- 2.12. In signing this addendum that is in terms of the POPIA, the Operator hereby agrees that it has adequate measures in place to provide protection of the personal information and the information of a third party given to it by Transnet in line with the 8 conditions of the POPIA and that it will provide to Transnet satisfactory evidence of these measures whenever called upon to do so by Transnet.



TRANSNET PORT TERMINALS

TENDER NUMBER: TPT/2023/09/0013/43177/RFP

DESCRIPTION OF THE SERVICES: FOR THE SUPPLY OF SERVICES TO REFURBISH STACKER RECLAIMER 3 AT THE SALDANHA IRON ORE TERMINAL FOR TRANSNET SOC LTD (REG.NO.1990/000900/30) OPERATING AS TRANSNET PORT TERMINALS, (HEREINAFTER REFERRED TO AS "TPT"), AS A ONCE OFF SUPPLY.

The Operator is required to provide confirmation that all measures in terms of the POPIA are in place when processing personal information and the information of a third party received from Transnet:

YES	
------------	--

NO	
-----------	--

2.13. Further, the Operator acknowledges that it will be held liable by Transnet should it fail to process personal information in line with the requirements of the POPIA. The Operator will be subject to any civil or criminal action, administrative fines or other penalty or loss that may arise as a result of the processing of any personal information that Transnet submitted to it.

2.14. Should a Tenderer have any complaints or objections to processing of its personal information, by Transnet, the Tenderer can submit a complaint to the Information Regulator on <https://www.justice.gov.za/inforeg/>, click on contact us, click on complaints.IR@justice.gov.za

3. SOLE AGREEMENT

3.1. The Agreement, constitute the sole agreement between the parties relating to the subject matter referred to in paragraph 1.1 of this and no amendment/variation/change shall be of any force and effect unless reduced to writing and signed by or on behalf of both parties.

Signed at _____ on this _____ day of _____ 2021

Name: _____

Title: _____

Signature: _____

..... **(Pty) Ltd**

(Operator)

Authorised signatory for and on behalf of (Pty) Ltd who warrants that he/she is duly authorised to sign this Agreement.

AS WITNESSES:

1. Name: _____ Signature: _____

2. Name: _____ Signature: _____



T2.2-23: Insurance provided by the *Contractor*

Clause 84.1 in NEC3 Engineering & Construction Contract (June 2005)(amended June 2006 and April 2013) requires that the *Contractor* provides the insurance stated in the insurance table except any insurance which the *Employer* is to provide as stated in the Contract Data.

Please provide the following details for insurance which the *Contractor* is still to provide. Notwithstanding this information all costs related to insurance are deemed included in the tenderer's rates and prices.

Insurance against (See clause 84.2 of the ECC)	Name of Insurance Company	Cover	Premium
Liability for death of or bodily injury to employees of the <i>Contractor</i> arising out of and in the course of their employment in connection with this contract			
Motor Vehicle Liability Insurance comprising (as a minimum) "Balance of Third Party" Risks including Passenger and Unauthorised Passenger Liability indemnity with a minimum indemnity limit of R5 000 000/R10 000 000.			
Insurance in respect of loss of or damage to own property and equipment.			
Marine Craft Hull insurance in respect of all marine craft or vessels utilised in performance of the Works for a sum sufficient to provide for their replacement			
Protection and Indemnity Insurance in respect of all marine craft or vessels utilised in performance of the Works extended for Specialist Operations with a minimum indemnity limit of R 20,000,000			
(Other)			



T2.2-24: Form of Intent to Provide a Performance Guarantee

It is hereby agreed by the Tenderer that a Performance Guarantee drafted **exactly** as provided in the tender documents will be provided by the Guarantor named below, which is a **bank or insurer registered in South Africa**:

Name of Guarantor
(Bank/Insurer)

.....

Address

.....

The Performance Guarantee shall be provided within **2 (Two)** weeks after the Contract Date defined in the contract unless otherwise agreed to by the parties.

Signed

.....

Name

.....

Capacity

.....

On behalf of (name of tenderer)

.....

.....

Date

.....

Confirmed by Guarantor's Authorised Representative

Signature(s)

.....

Name (print)

.....

Capacity

.....

On behalf of Guarantor
(Bank/insurer)

.....

Date

.....



T2.2-25: Foreign Exchange Requirements

If Secondary Option X3 is included in the *conditions of contract* of the NEC3, the Tenderer to provide detailed breakdown of items that will have a foreign exchange implication.

Justification and full details supporting foreign currency requirements to be appended to this Schedule.

Items & activities	Currency	Bank	Maximum payment

The *exchange rates* to be used are stated in the Contract Data provided by the *Employer*.

It is expected that the percentages of foreign currency or currencies quoted are realistic and that they adequately reflect the overall foreign component of cost.

Due to the introduction of International Financial Reporting Standards IS32 and IS39, the *Employer* may not be able to accommodate a tenderer’s requirements in full or at all.



TRANSNET PORT TERMINALS

TENDER NUMBER: TPT/2024/03/0066/60631/RFP

DESCRIPTION OF THE SERVICES: FOR THE SUPPLY OF SERVICES TO REFURBISH STACKER RECLAIMER 3 AT THE SALDANHA IRON ORE TERMINAL FOR TRANSNET SOC LTD (REG.NO.1990/000900/30) OPERATING AS TRANSNET PORT TERMINALS, (HEREINAFTER REFERRED TO AS "TPT"), AS A ONCE OFF SUPPLY.

T2.2-26: Forecast Rate of Invoicing

Tenderer to submit the forecast rate of invoicing (cash-flow) based on the Tender Price and Tender Programme.

Index of documentation attached to this schedule:

.....

.....

.....

.....

.....

.....

.....

.....

.....



T2.2-27: Three (3) years audited financial statements

Attached to this schedule is the last three (3) years audited financial statements of the single tenderer/members of the Joint Venture.

NAME OF COMPANY/IES and INDEX OF ATTACHMENTS:

.....

.....

.....

.....

.....

.....

.....

.....



SCOPE OF WORK
SUPPLY OF SERVICES TO REFURBISH STACKER RECLAIMER 3 AT THE SALDANHA IRON ORE TERMINAL

APPROVAL ROUTING SLIP

Project Name : SR3, CV116
 Project Number : Z.5200191
 Scope Description : Supply of Services to Refurbish Stacker Reclaimer 3 at the Saldanha Iron Ore Terminal

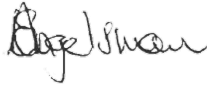
Signatories		Signature	Date	Comments
Francois Horton Programme Manager	Compiled		04/03/2024	
Carols Engelsman Senior Engineering Manager	Approved		04/03/2024	

PART C3: SCOPE OF WORK

Document reference	Title	No of pages
C3.1	This cover page	1
	<i>Employer's Works Information</i>	38
Total number of pages		39

C3.1 EMPLOYER'S WORKS INFORMATION

Contents

PART C3: SCOPE OF WORK.....	1
SECTION 1.....	4
1 Description of the <i>works</i>	4
1.1 Executive overview.....	4
1.2 Employer's objectives.....	4
1.3 Interpretation and terminology.....	4
2 Engineering and the Contractor's design.....	6
2.1 Employer's design.....	6
2.2 Parts of the <i>works</i> which the Contractor is to design.....	6
2.3 Procedure for submission and acceptance of Contractor's design.....	6
2.4 Review and Acceptance of Contractor Documentation.....	6
2.5 Other requirements of the Contractor's design.....	6
2.6 Design of Equipment.....	6
2.7 Equipment required to be included in the <i>works</i>	7
2.8 As-built drawings, operating manuals and maintenance schedules.....	7
3 Construction.....	7
3.1 Temporary <i>works</i> , Site services & construction constraints.....	7
3.2 Completion, testing, commissioning, and correction of Defects.....	12
4 Plant and Materials Standards and Workmanship.....	13
4.1 Site Location & General Layout.....	13
4.2 Scope of Works Background.....	14
4.3 Scope of Works.....	15
4.4 Site related items to be supplied with responsibility for providing.....	25
4.5 Construction / Execution / Commissioning.....	26
4.6 Method Statements.....	26
5 List of Drawings.....	27
5.1 As-Built Drawings.....	27
5.2 Drawings issued by the Employer.....	27
6 List of Annexures.....	28
6.1 Annexures issued by the Employer.....	28
SECTION 2.....	30



7	Management and start up	30
7.1	Management meetings	30
7.2	Documentation control	30
7.3	Safety risk management.....	31
7.4	Environmental constraints and management.....	31
7.5	Quality assurance requirements	32
7.6	Programming constraints	32
7.7	Contractor’s management, supervision and key people.....	34
7.8	Training workshops and technology transfer.....	35
7.9	Contract change management.....	35
7.10	Provision of bonds and guarantees	36
7.11	Records of Defined Cost, payments & assessments of compensation events kept by <i>Contractor</i>	36
8	Procurement.....	36
8.1	Code of Conduct	36
8.2	The <i>Contractor’s</i> Invoices	37
8.3	People.....	38
8.4	Subcontracting.....	38
8.5	Plant and Materials	38
8.6	Tests and inspections before delivery.....	39
8.7	Marking Plant and Materials outside the Working Areas	39
8.8	<i>Contractor’s</i> Equipment (including temporary <i>works</i>).....	39
8.9	Preparation of post Completion contracts.....	40

SECTION 1

1 Description of the works

1.1 Executive overview

The works that the Contractor is to perform involve conducting a major refurbishment on Stacker Reclaimer 3 and Tripper Car 3 at the Bulk Terminal of Saldanha (BTS). Stacker Reclaimer 3 and Tripper Car 3 is Bulk Material Handling Equipment (BMH).

The Stacker Reclaimer 3 and Tripper Car 3 asset at the Port of Saldanha which was commissioned in 2005 requires a major refurbishment.

The BTS has little operational redundancy when handling Iron Ore volumes up to 60mtpa with bulk material handling equipment reaching, and in some cases exceeding their mid-life refurbishment periods.

A major refurbishment is an opportunity to address equipment reliability issues.

The refurbishment is required to ensure the optimal operational use and availability of the BMH equipment at the BTS. The goal of the refurbishment project is to ensure that the BMH equipment operates safely and reliably for the remainder of their operational life.

This refurbishment is not an equipment upgrade and no increase in volume throughput is required.

1.2 Employer's objectives

The Employer's objective is to sustain itself as the premier bulk export terminal for iron ore in South Africa. To achieve this strategic intent, the terminal needs to operate, maintain and sustain its BMH facilities and equipment in a safe, efficient and cost-effective manner.

The BTS has developed a Sustaining Programme which gives effect to its strategic intent and which outlines the following three strategic objectives and their deliverables:

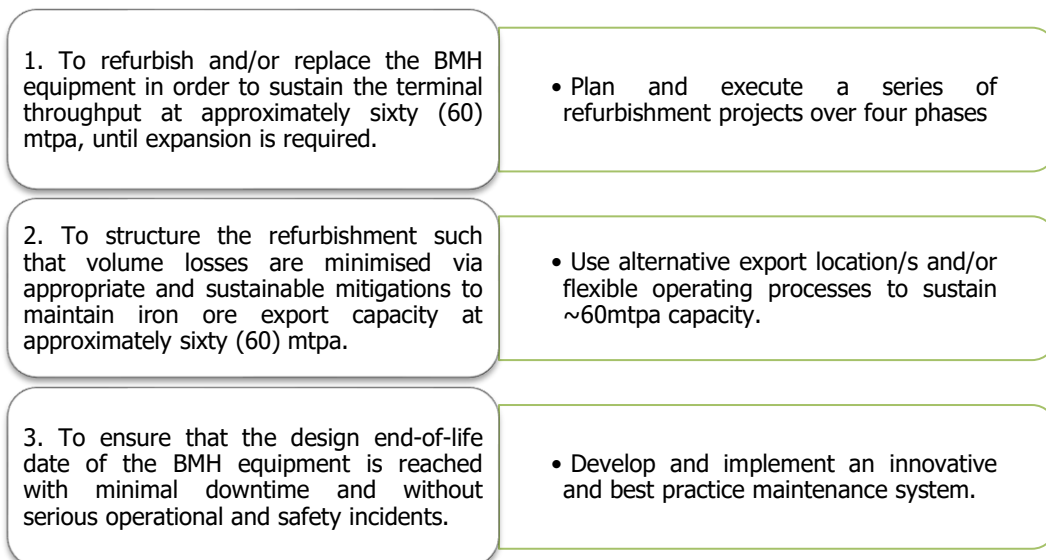

1.3 Interpretation and terminology

The following abbreviations are used in this Works Information:

Abbreviation	Meaning given to the abbreviation
AIA	Authorised Inspection Authority



Abbreviation	Meaning given to the abbreviation
BBBEE	Broad Based Black Economic Empowerment
BMH	Bulk Material Handling
BTS	Bulk Terminal of Saldanha
CEMP	Construction Environmental Management Plan
CD	Compact Disc
CDR	Contractor Documentation Register
CDS	Contractor Documentation Schedule
CIRP	Contractor's Industrial Relations Practitioner
CMC	Construction Management Team
CRL	Contractor Review Label
CSHEO	Contractor's Safety, Health and Environmental Officer
CM	Construction Manager
DTI	Department of Trade and Industry
DGN	Drawing File
DWG	Drawings
EDMS	Electronic Document Management System
EO	Environmental Officer
HAW	Hazard Assessment Workshop
HAZOP	Hazard and Operability Study
HSSP	Health and Safety Surveillance Plan
INC	Independent Nominated Consultant
IP	Industrial Participation
IR	Industrial Relations
IPP	Industrial Participation Policy
IPO	Industrial Participation Obligation
IPS	Industrial Participation Secretariat
IRCC	Industrial Relations Co-ordinating Committee
JSA	Job Safety Analysis
Native	Original electronic file format of documentation
NDT	Non-Destructive Testing
NOSA	National Occupational Safety Association
OEM	Original Equipment Manufacturer
OHS	Occupational Health and Safety
OHSAS	Occupational Health and Safety Act of South Africa
PES	Project Environmental Specifications
PHA	Preliminary Hazard Assessment
PIRM	Project Industrial Relations Manager
PIRPMP	Project Industrial Relations Policy and Management Plan
PLA	Project Labour Agreements
PSIRM	Project Site Industrial Relations Manager
PSPM	Project Safety Program Manager
PSSM	Project Site Safety Manager
ProgEM	Programme Environmental Manager
ProjEM	Project Environmental Manager
QA	Quality Assurance
R&D	Research and Development

Abbreviation	Meaning given to the abbreviation
SANS	South African National Standards
SASRIA	South African Special Risks Insurance Association
SES	Standard Environmental Specification
SHE	Safety, Health and Environment
SHEC	Safety, Health and Environment Co-ordinator
SIP	Site Induction Programme
SOP	Standard Operating Procedure
SMP	Safety Management Plan
SSRC	Site Safety Review Committee
TIMS	Transnet Integrated Management System
TPT	Transnet Port Terminals

2 Engineering and the *Contractor's* design

2.1 *Employer's* design

2.1.1 The *Employer* will not be conducting any design work on this project. The *Employer* herewith requests the *Contractor* to execute the refurbishment work in accordance with the original design of the OEM and to ensure that the original safe operational design life of twenty years is maintained, in line with the original designed throughput capacity.

2.2 Parts of the *works* which the *Contractor* is to design

2.2.1 The *Contractor* will not be designing any parts of the *works*.

2.3 Procedure for submission and acceptance of *Contractor's* design

2.3.1 The *Contractor* will not be designing any parts of the *works*, thus no applicable procedure for submission of design documentation.

2.4 Review and Acceptance of *Contractor* Documentation

The *Contractor* submits documentation as the '*Works* Information' requires to the *Project Manager* for review and acceptance.

In undertaking the '*Works*' (including all incidental services required), the *Contractor* shall conform and adhere to the requirements of the '*Contractor* Document Submittal Requirements' Standard included in Annexure 1 (Refer DOC-STD-0001).

2.5 Other requirements of the *Contractor's* design

2.5.1 The *Contractor's* design (if required) shall comply with the original OEM's design standards and specifications.

2.5.2 The *Contractor* grants the *Employer* a licence to use the copyright in all design data presented to the *Employer* in relation to the *works* for any purpose in connection with the construction, re-construction, refurbishment, repair, maintenance and extension of the *works* with such licence being capable of transfer to any third party without the consent of the *Contractor*.

2.6 Design of Equipment

2.6.1 In the event of any design, the *Contractor* submits his design details of his proposed Equipment in terms of NEC3 ECC Clause 23 to the *Project Manager* for his acceptance.

2.7 Equipment required to be included in the works

2.7.1 It is the *Contractor's* responsibility to ensure that the correct equipment required to execute the Works is sourced as part of this tender. The Contractor to cater for at least the following equipment to complete the work:

- Craneage
- Scaffolding
- Generators
- Cherry Pickers
- Low bed truck for transport

2.8 As-built drawings, operating manuals and maintenance schedules

2.8.1 The *Contractor* provides the following:

- As-built drawings (electronic [dwg/dxf and pdf format] and 4 x hard copies)
- Operating manuals [electronic and 3 x hard copies)
- Maintenance manuals (electronic and 3 x hard copies)

2.8.2 As-Built/Final Documentation

In undertaking the 'Works' (including all incidental services required), the *Contractor* shall conform and adhere to the requirements of the 'Contractor Document Submittal Requirements' Standard included in Annexure 1 (Refer DOC-STD-0001).

The *Contractor* submits final documentation to the *Project Manager* within 1-month of handing-over the refurbished *Stacker Reclaimer 3 and Tripper Car 3* to the *Employer*. This final documentation is submitted as "Certified", "As-built", or "Finally Accepted" by the *Project Manager* or "Without Comment" documentation or documentation for which no further review is required. The final documentation is to eventually form part of the *Contractor* final Manuals or Data Books.

2.8.3 Installation, Maintenance and Operating Manuals and Data Books

In undertaking the 'Works' (including all incidental services required), the Supplier shall conform and adhere to the requirements of the 'Data Books and Manuals' Standard included under section 11 of Annexure 1, DOC-STD-0001.

3 Construction

3.1 Temporary works, Site services & construction constraints

3.1.1 *Employer's* Site entry and security control, permits, and Site regulations

The *Employer's* requirements, which the *Contractor* is to comply with, are stipulated in the Health & Safety Specification, Health & Safety Management Plan & Security Management Plan

The *Contractor* complies with the following requirements of the *Employer*:

- Access control procedures
- Medical and Induction procedures
- Legal appointments and training requirements

3.1.2 The *Contractor* complies with the following requirements of the *Employer*:

The *Contractor* shall visit the Site of the proposed works and acquaint themselves with the nature of the works, the conditions under which the work is to be performed, the means of access to the Site, and all further matters that may influence or affect the contract.

The *Contractor* shall be deemed to have allowed in their tender for any additional cost to be involved due to the foregoing, as no claims for any extras in connection with the position or nature of the works will be entertained.

The *Contractor* shall obtain the necessary work permit(s) from the authority having jurisdiction at the Site (i.e. TPT and/or TNPA) prior to commencing with any of the works on site.

3.1.3 Restrictions to access on Site, roads, walkways and barricades

The Contractor to use the roads in accordance with the Health and Safety Management Plan, Port Rules and National Road Traffic Regulations.

The battery limits for the site offices and laydown area and parking area are shown in the figure below.

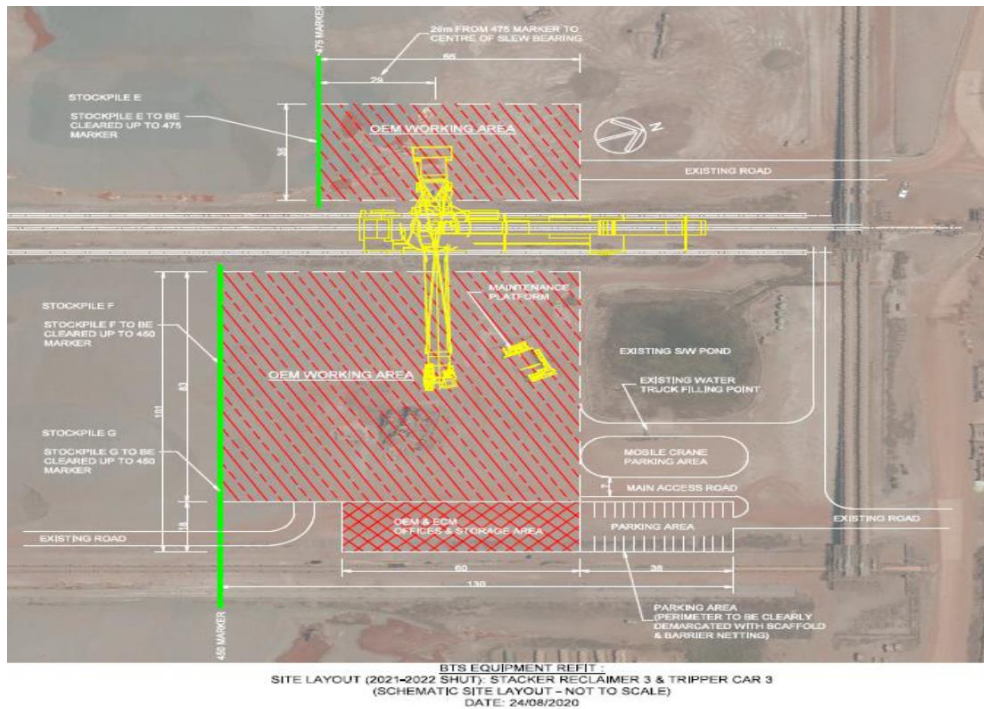

Figure 1 - Laydown area & site offices and parking

3.1.4 The Contractor complies with the following requirements of the Employer:

The Contractor shall comply with the standard conditions of entry and exit for all temporary permit holders, as defined by the Employer. It is the responsibility of the Contractor to ensure that all his employees are properly versed as to what these are.

Access and Permits within Port Boundary and TPT Property: Application letter must be typed on an official company letterhead, dated and signed by a senior company official or appointed official with the following information attached:

- Business to be undertaken in the Port
- Areas where access is required (be specific)
- Period required (duration) – maximum of 1 month (30 days)
- I.D number/s of the person/s requiring the permit/s

The Contractor shall arrange all necessary entry and other permits for all his staff. All Costs incurred in this regard shall be borne by the Contractor.

SAPS Name Clearance: Each of the Contractor's employees shall have a valid SAPS Name clearance certificate.

Vehicle permits: The Contractor shall submit a list of all vehicles entering and leaving the port area, to TNPA for issuing of vehicle permits. The list shall include the type, model and registration number of the vehicle, as well as the name of the designated driver.

Contractor's Materials, Plant and Equipment: All Contractor's Materials, Plant and Equipment brought into the port area shall be declared at the main security entrance. The same declaration by the Contractor to TPT security personnel shall apply for the abovementioned on TNPA property. The documentation for such Materials, Plant and Equipment shall be presented to the TNPA and TPT security persons respectively whenever these are removed again.

Employee's Equipment: Should the Contractor ever be required to take any of the Employer's Equipment out of the port boundaries, such Equipment shall be identified and declared in accordance with the TNPA gate pass procedures. The same shall apply on TPT property in accordance with their procedures.

Tool lists: All tools brought into the port area shall be declared at the TNPA main security entrance. Tools are to be assigned to a designated vehicle for further control during entrance and departure from the port area.

Material dispatch register to be maintained for all equipment leaving the Port.

Site Security Service Provider: A Transnet appointed service provider list is available from TPT Security.

The Site is located within the limits of the Port of Saldanha. Apart from when gaining entry or exit, the *Contractor* shall ensure that his staff members do not move about in areas where they are not permitted to be. This includes all areas outside the installation sites, the site office and access roads.

Staff members shall refrain from moving along private roads, including the Haul Road and service roads, without the necessary authorizations and permits. The *Contractor* shall provide adequate transport for all staff members between the installation sites and the site office, as well as transport to work and from work.

In addition, staff members shall refrain from coming close to or crossing the operational rail lines or conveyor line assemblies, unless travelling in a construction vehicle and crossing at an official demarcated crossing.

Staff members shall refrain from entering buildings currently occupied by the *Employer's* employees or third parties, unless required for specific work purposes.

3.1.5 People restrictions on Site; hours of work, conduct and records:

The *Contractor* complies with the following hours of work for his people (including Subcontractors) employed on the Site: The *Contractor* to allow and plan for his workforce to work on a 24/7 basis, for the scheduled refurbishment period. *Contractor* to obtain approval, to work the extended working hours, from the Department of Labour before commencement of site establishment. Labour plan should indicate that all workmen will get enough time-off as required by Law.

3.1.6 The *Contractor* keeps daily records of his people engaged on the Site and Working Areas (including Subcontractors) with access to such daily records available for inspection by the *Project Manager* at all reasonable times.

3.1.7 Health and safety facilities on Site

Health and Safety requirements for this project are stipulated in the Health and Safety Specification, Health and Safety Management Plan and TIMS Contractor Health and Safety Specification Guideline. Refer Annexures 2 and 11.

3.1.8 Environmental controls, fauna & flora, dealing with objects of historical interest

Environmental requirements for this project are stipulated in the Environmental Baseline Report and Environmental Risk Assessment. Refer Annexures 3 and 4.

3.1.9 Title to Materials from demolition and excavation

The *Project Manager* instructs the *Contractor* how to table, mark, set aside and/or dispose of such materials for the benefit of the *Employer* in accordance with NEC3 ECC Clause 73.1.

The *Contractor* has no title to materials from demolition, excavation or removal of existing equipment that are being replaced.

3.1.10 Cooperating with and obtaining acceptance of others

Successful completion of the contract depends on the effective interaction and co-operation of all Parties on Site. It is necessary to discuss the *Contractor's* proposed activities and short-term programme on a day-to-day basis with the *Project Manager*, to ensure effective co-operation and a smooth interface between the activities of the *Contractor* and Others working and operating in this area. This is in accordance with NEC3 ECC Clause 25.

Ongoing commercial activities by the *Employer* or third parties shall take precedence over any construction activities.

3.1.11 Publicity and progress photographs

Contractors must be in the possession of a valid photo permit, obtained from TNPA, to take any project specific photographs i.e., progress photos. No photos, other than those specific to the project, can be taken.

3.1.12 Advertisement and Media Communication

The *Contractor* does not advertise the contract or the project to any third party, nor communicate directly with the media (in any jurisdiction) whatsoever without the express written notification and consent of the *Project Manager*.

3.1.13 Contractor's Equipment

The *Contractor* keeps daily records of his Equipment used on Site and the Working Areas (distinguishing between owned and hired Equipment) with access to such daily records available for inspection by the *Project Manager* at all reasonable times.

3.1.14 Equipment provided by the Employer

The *Employer* will not be making equipment available for use by the *Contractor*.

3.1.15 Site services and facilities:

The position of existing supply connection points for electricity and water are to be indicated by the *Project Manager* to the *Contractor*. The *Contractor* is to make his own arrangements for the connection of such services to his Working Areas, for his use during construction.

An electrical connection point (220V and 380/525V) will be supplied by the *Employer* within 50 m the site yard. *Contractor* to supply cable and distribution board for welding and 220V. *Contractor* to complete installation of electrical connection and provide Certificate of Compliance (COC). The *Contractor* is to provide his own power in the event of a power failure or disruptions caused by other tie-in activities affecting the greater BTS normal power supply, and is to have a generator on standby, thus not causing any delays in the execution of the works.

The *Employer* will supply a water point, 50m from the site yard. It is the *Contractors* responsibility to distribute the water from this point onwards. There is no water-borne sewerage facility available. *Contractor* to provide drinking water for all employees, inclusive of sub-contractors under his control.

The cost of meters, connections, and all other usage costs associated with the provision of services are for the *Contractor's* account.

The *Contractor* is to supply his own compressed air if required to execute the works.

The *Employer* does not provide any security for the works for the duration of the contract and will not be responsible for any damage and/or losses incurred by the *Contractor* in this regard.

Wherever the *Employer* provides facilities (including, inter alia, temporary power, water, waste disposal, etc) for the *Contractors* use within the Working Areas and the *Contractor* adapts such facilities for use, then the *Contractor* makes good and provides full reinstatement to the land (including all apparatus of the *Employer* and Others in, on or under the land) and surrounding areas to its original standard upon dismantling of such facilities and hand-back to the *Employer*.

3.1.16 The Employer provides the following facilities for the Contractor:

An area for the *Contractor's* Site Establishment will be made available, free of charge, to the *Contractor* for the duration of the contract. The *Contractor* establishes his offices, lay down area, stores, and parking area in this location.

The *Contractor* ensures that the Site establishment area has a suitable security fence and the necessary access gates and control. The *Contractor* does not encroach in any way on any operational area outside the fencing footprint. This prohibition includes foot traffic. To ensure this, the temporary site fence must be erected before any other work can start.

All preparation and fencing are to be done by the *Contractor* for his account. The Site establishment area is to be clearly signposted and compliant with the relevant safety regulations and restrictions that might be in place until the *Contractor* has de-established from the site. The *Project Manager*, or his duly appointed representative, must accept the Site establishment layout prior to erection.

3.1.17 Facilities provided by the *Contractor*:

Ablution facilities: There is no water-borne sewerage facility available. The *Contractor* provides, maintains, moves to new positions as required and finally removes portable chemical toilets of sufficient number at his cost. Toilets are to be properly constructed and placed in suitable positions and maintained in a clean and sanitary working condition. The *Contractor* makes his own arrangements with the Local Authority for the disposal of night soil at his cost. The *Contractors* ablution facilities will be shared with the TPT/CMC Team.

Housing and Accommodation: Housing on Site, at the *Contractor* camp or in the Port area is not permitted. The *Contractor* is to supply suitable accommodation, off-site, for his workforce.

Offices for *Contractor*: The *Contractor* is to provide his own suitable temporary office facilities, to be placed within the confines of the identified site camp, for the use of his Project Team. Suitable eating/changing facilities to be provided for the *Contractors* workforce.

Temporary Lighting and Fencing: The *Contractor* provides temporary lighting and fencing around every section occupied by them during the refurbishment works period. Such fencing demarcates and secures the construction area and is erected before work commences and is removed only upon Completion of the works. The *Contractor* includes for all costs such as lighting and fencing, including access control into and out of these restricted areas. The *Project Manager's* acceptance is to be obtained for the use of any temporary lighting on the Site due to the impact that this may have on vessel traffic and operations in the harbour and/or interference with surrounding operations. See Annexure 8, Security Management Plan, for detail and specifications. The lighting must be sufficient so that the works can be executed safely during night shifts.

***Contractor's* responsibility:** Unless expressly stated as a responsibility of the *Employer* in this document, site services and facilities and all residual requirements for the provision of facilities and all items of Equipment necessary for the *Contractor* to provide the Works, remain the responsibility of the *Contractor*.

Giving notice of work to be covered up: The *Contractor* notifies the *Project Manager* in writing of any elements of the works which are to be covered up, not less than 24 (twenty-four) hours prior to proposed covering up.

3.1.18 The *Contractor* provides the following facilities for the *Project Manager* and *Supervisor*:

The *Contractor* is to provide a suitable temporary office for the TPT project team (6 workstations with chairs). The *Contractors* ablution facilities will be shared with the TPT project team.

3.1.19 Wherever the *Contractor* provides facilities (either his own or for the *Project Manager* and/or *Supervisor*) and all items of Equipment, involving, *inter alia*, offices, accommodation, laboratories, Materials storage, compound areas etc, within the Working Areas, then the *Contractor* makes good and provides full reinstatement to the land (including all apparatus of the *Employer* and Others in, on or under the land) and surrounding areas to its original standard, upon dismantling of such facilities and items of Equipment.

3.1.20 Unless expressly stated as a responsibility of the *Employer* as stated under 3.1.15 Site services and facilities, all residual requirements for the provision of facilities and all items of Equipment necessary for the *Contractor* to Provide the Works remains the responsibility of the *Contractor*.

3.1.21 The *Contractor* inspects the existing adjoining works / premises / properties / with which the works interfaces in conjunction with the *Project Manager* prior to starting his own work where it is considered that the *Contractor* may be held liable for damage caused to the existing plant or equipment. A detailed photographic report will be required.

3.1.22 The control of noise, dust, water, and waste from the activities by the *Contractor* as part of this Contract, shall be the responsibility of the *Contractor*. The *Contractor* shall comply with the TIMS Contractor Environmental and Sustainable Specification Guideline. Refer Annexure 10.

3.1.23 The *Contractor* complies with the local bylaws and other statutory regulations with regards to the control of noise, dust, water, and waste control.

3.1.24 The *Contractor* complies with the following constraints in the execution of the works: Full Port operations shall be maintained to the areas not affected by the *Contractors* works. At all other times, the *Contractor* shall ensure that he does not interfere or restrict any of the port operations at any time, during the refurbishment period.

- 3.1.25 The *Contractor* shall be responsible for the commissioning of the scope of works, so that it can be handed over to BTS Engineering/Operations for them to reintegrate it in the existing BTS operational system.

3.2 Completion, testing, commissioning, and correction of Defects

- 3.2.1 The *work* to be done by the Completion Date

The site erection methodology and work method shall be as agreed between the *Project Manager* and the *Contractor*, considering the interface requirements with other Site activities by Others, and the demands of the Port Operations during the Contract period.

On or before the Completion Date the *Contractor* shall have done everything required to provide the Works which are to be done before the Completion Date. The *Project Manager* cannot certify Completion until all the Works have been done and are free of Defects, which would have, in his opinion, prevented the *Employer* from using the works and Others from doing their work.

- 3.2.2 The *Contractor* is permitted to carry out the following *works* after Completion:

The Contractor is permitted to carry out performance testing of the works immediately after Completion which consists of BTS operating the machine stacking and reclaiming product for a total of 40 hours under fully designed load.

- 3.2.3 Use of the *works* before Completion has been certified:

Use of the *works* by the *Employer* before Completion has been certified shall not be required.

- 3.2.4 The *Contractor* provides the following commissioning activities to bring the *works* in use in liaison with the *Employer*:

Stage 1 – Pre-commissioning / Completion

The Stage 1 activities are all those activities that take place prior to Cold Commissioning including Mechanical/Electrical(E), Control and Instrumentation (C&I) and Physical completion ready to be subjected to functional testing, Punch listing (defect list) and completion of all Category A and B punch items. Mechanical/E, C&I and physical completion includes running the conveyor selection routes, flushing, hydro testing, pressure testing and other test necessary before being integrated into functional modules. Check direction of motors, check wiring connections, establish electrical power supplies at end users, and ensure that mechanical connections are tight and safe etc.

Stage 2 – Cold Commissioning

Cold Commissioning activities are those required to bring any plant system, stream, module, unit from the status of mechanical completion to the point where Hot Commissioning may commence under the supervisory control of the relevant contractor and the issue of Cold Commissioning Certificate. This will entail running the system, Module or Unit under no load conditions and where applicable, on automatic control with stimulations as required.

The activities cover a very wide range and include checks on electrical, motors, control and safety systems as well as running the plant under simulated conditions without load.

Perform all activities to ensure handover and issuing of Cold Commissioning certificate

Stage 3 – Hot Commissioning (System Integration and Load Tests)

This stage of Commissioning consists of placing of the Works into operation by BTS, TPT Projects team, Contractors and Equipment Suppliers, using the operating and maintenance personnel of BTS. Hot Commissioning includes performance testing of the Works in terms of the Contract.

For detail on commissioning requirements see Annexure 5, Commissioning Plan

- 3.2.5 Start-up procedures required to put the *works* into operation

The *Contractor* shall assist with the start-up procedures required to put the works into operation.

- 3.2.6 The *Employer* shall take over the Plant as soon as the Works have successfully passed any required Performance/Acceptance Test with only Category 'C' Punch List Items remaining with a commitment to complete the Category 'C' Punch List Items by an agreed date during the Defects Correction/Warranty Period and following the application by Contractor for a Completion Certificate, a Completion Certificate will be issued.

- 3.2.7 The *Contractor* ensures that the *Project Manager* has a full and accurate dossier of As-built documents that represent the combined Structural, Mechanical, Electrical and, Controls and Instrumentation status of the completed works (to include Plant within the works), to present to the *Employer*, as appropriate at the earlier of take-over or Completion.
- 3.2.8 The *Contractor* ensures that the *Project Manager* has a full and accurate dossier of Maintenance and Operating Manuals at the earlier of take-over or Completion of any new equipment that replaced old equipment as part of the refurbishment, where the new equipment is of a different or newer technology or design.
- 3.2.9 The *Contractor* modifies and updates As-built documents as necessary prior to Completion.
- 3.2.10 Access given by the *Employer* for correction of Defects shall be arranged by the *Project Manager*, and if such correction requires the Plant and Materials to be shut down, the timing and period of the shutdown shall be scheduled to suit the Port Operations. For the period of shutdown to correct defects, the *Contractor* shall take over the Plant and Materials, and accept all risks that were assumed as part of the original Contract for the period until handing over the Plant and material to the *Employer* after correcting the defects.
- 3.2.11 The *Contractor* complies with the following constraints and procedures of the *Employer* where the *Project Manager* arranges access for the *Contractor* after Completion: Security access requirements, restrictions to areas which do not form part of the site, safety precautions that need to be taken as part of the Site Management Plan, and safety inductions of staff.
- 3.2.12 The *Contractor* performs the following performance tests after Completion of the works:
- Operational tests without material during Cold Commissioning.
 - Endurance/Proofing test of 40 hours under full designed load as a complete operating system.
 - A Hot Commissioning Certificate will be signed-off by BTS on completion of endurance tests, with handover to BTS.
- 3.2.13 The *Contractor* facilitates training workshops with the *Employer's* nominated staff on any new technology introduced on the plant after Completion of the works.

4 Plant and Materials Standards and Workmanship

4.1 Site Location & General Layout

The Port of Saldanha is located about 120km to the north of Cape Town in the Western Cape of South Africa. The Port operates 24/7, 355 days of the year (an annual 10-day shutdown is used to conduct heavy maintenance) exporting circa 60mtpa of Iron Ore via the Bulk Terminal Saldanha (BTS).

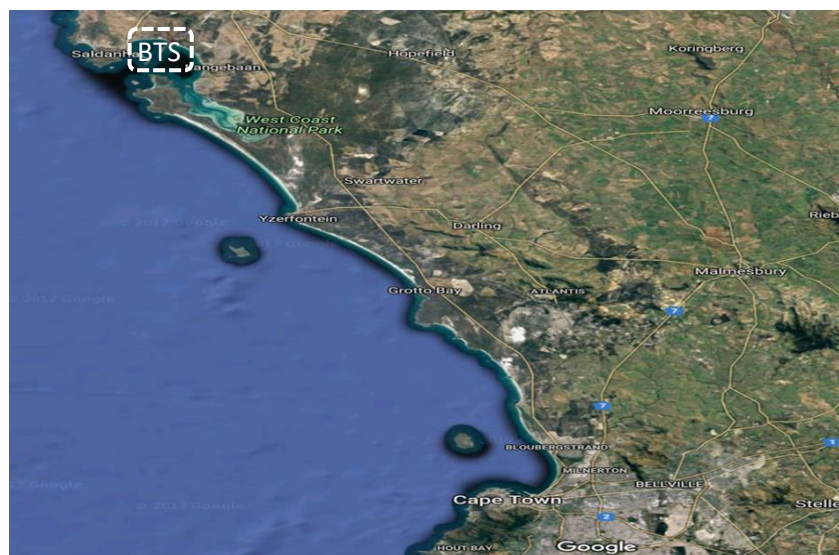

Location Diagram



General Layout

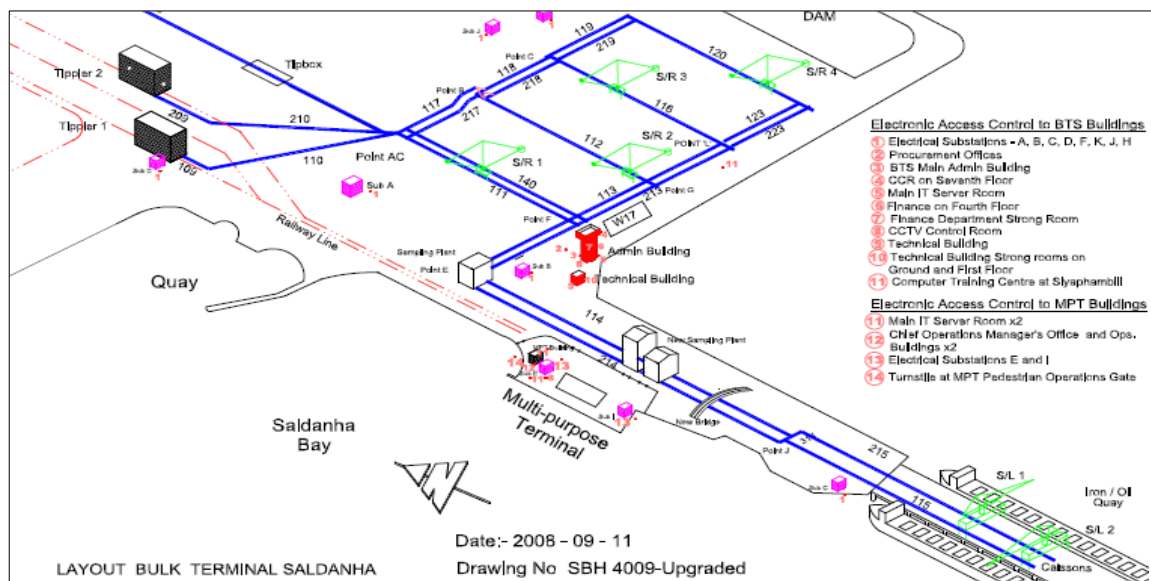

Schematic layout of the Saldanha Bulk Terminal

4.2 Scope of Works Background

During the scope finalization of the mid-life refurbishment the following were taking into consideration:

- Installation of technological improvements,
- carry out structural repairs,
- implement large scale corrosion protection,
- renew the integrity of electrical components of the asset,
- refurbish components or systems that are normally only exposed to maintenance services, e.g., gearboxes, to ensure life expectancy and maintain reliability,
- upgrade components that have become obsolete, and
- replace components where interchangeability with replacement parts is not possible without equipment outage.

The scope of the mid-life refurbishment in relation to Stacker Reclaimer 3 & Tripper Car 3 was categorized into three (3) engineering disciplines, namely: mechanical, structural and, electrical, control and instrumentation as follows:

- Mechanical - includes components or systems such as the open gear systems, gearboxes, hydraulic systems, and rotating and moving parts (e.g., trunnions, car-clamps).
- Structural - includes wear liners, supporting structures (if required) and areas of possible structural damage (cracking deformation wear). Additionally, includes maintenance detection (e.g., non-destructive testing for fatigue fracturing) of areas where access to certain structures that is not normally possible while equipment is in service.

- Electrical, control and instrumentation (EC&I) - includes panels and drives that is approaching the end of their useful life, or has become obsolete or, where newer technologies can be incorporated.

4.3 Scope of Works

The scope of works (SOW) that the *Contractor* is to perform for the mid-life refurbishment of Stacker Reclaimer 3 & Tripper Car 3 can be summarised as follows:

4.3.1 Site establishment

Supply, transportation, off-loading and placement of all temporary offices, equipment and all other infrastructure required for execution of the *works*. Timeous finalizing of all training, medicals, permits, and other documentation required, to commence with the execution works.

4.3.2 Execution of SOW activities

Execution of all SOW activities planned for the mid-life refurbishment and listed under 4.3.7 below.

4.3.3 Management & resources

Site and HQ Management, Site Supervision, SHEQ Management, Site labour to work 24/7 or less depending on the programme's requirements within labour laws Compliance with the Department of Labour (DoL) with an approved mandate for extended working hours (If required), PPE, security-requirements, site equipment, craneage, vehicles, general tools, jacking tools/trestles, scaffolding, lighting, and others.

4.3.4 Commissioning

Pre-, Cold-, and Hot Commissioning, on completion of the refit shut work, to ensure that *works* is handed over to the *Client* in "Safe for Operation" mode. See Annexure 5, Commissioning Plan for detailed requirements.

4.3.5 Project close out

Project close out to be formally documented to cover all aspects of safety, training, as-built / red-line drawings, user manuals and updated maintenance procedures. All close out documentation to be handed over to the Client in hard copy format, as well as in electronic format.

4.3.6 Site de-establishment Removal from site of all temporary offices and infrastructure, equipment, tools etc., belonging to the *Contractor*. Clear the site and hand back to the *Client*

4.3.7 Scope of works (Technical Scope)

The following table lists the technical scope to be executed.

Note: For all structural, Mechanical and Electrical scope – refer to WCS Reports.

- SR3 E, C & I Condition Assessment
- SR3 Mechanical Condition Assessment
- SR3 Structural Condition Assessment

Table 1 - SCOPE

EQUIPMENT REFIT PROJECT (PHASE 4)				
STACKER RECLAIMER 3				
Item	DESCRIPTION	Sum	WCS Report	Report Item No.
1	<p>For the 2024 Shut: Preliminary and General, project management and overhead costs, all labour, cramage, equipment, vehicles, tools, access requirements, assessing free issue equipment, civils works for site establishment and execution of works, also including meeting the requirements of Health and Safety, Environmental, Quality, Construction Management, Execution and Commissioning, as stipulated in the Scope of Work. To cater for site establishment and de-establishment for the 2024 Shut.</p> <p>Contractor to provide a detailed cost breakdown for this item.</p>	Sum		
2	<p>For the 2025 Shut: Preliminary and General, project management and overhead costs, all labour, cramage, equipment, vehicles, tools, access requirements, assessing free issue equipment, civils works for site establishment and execution of works, also including meeting the requirements of Health and Safety, Environmental, Quality, Construction Management, Execution and Commissioning, as stipulated in the Scope of Work. To cater for site establishment and de-establishment for the 2025 Shut.</p> <p>Contractor to provide a detailed cost breakdown for this item.</p>			
3	<p>Training</p> <p>Any training/ familiarization of installed equipment.</p> <p>The Contractor facilitates training workshops with the Employer's nominated staff on any new technology introduced on the plant after Completion of the works.</p>	Sum		
4	<p>SR3 & TC3 high pressure Cleaning</p> <p>Contractor to clean SR3 and Tripper Car 3 by means of high-pressure water in preparation for Corrosion Protection activities.</p>	Sum	Structural	Note 2
5	<p>Drive/Idle wheel bogie assemblies for Stacker Reclaimer</p> <p>Remove eight (8) existing assemblies and replace it with assemblies that will be free issued.</p> <p>Refurbish the eight (8) assemblies that were removed and return as spares. Refurbishment to include new shaft, motor, gearbox, seal kit, wheels, bearings, and travel brakes.</p>	Sum	Mechanical Electrical	Item no. 1, 2, 3, 4, Item no. 9, 14, 15
6	<p>Single Idle Wheel assemblies for Tripper Car</p> <p>Remove four (4) existing single idle wheel bogie assemblies and replace it with assemblies that will be free issued.</p> <p>Refurbish four (4) single idle wheel bogie assemblies that were removed for the TC and return as spares.</p>	Sum	Mechanical	Item no. 1, 2, 3, 4

EQUIPMENT REFIT PROJECT (PHASE 4)				
STACKER RECLAIMER 3				
Item	DESCRIPTION	Sum	WCS Report	Report Item No.
7	<p>Double Idle Wheel assemblies for Tripper Car</p> <p>Remove five (5) existing double idle wheel assemblies and replace it with spares that will be free issued.</p> <p>Refurbish the five (5) double idle wheel assemblies that were removed for the TC and return as spares.</p>	Sum	Mechanical	Item no. 1, 2, 3, 4
8	<p>Wheel assemblies for SR</p> <p>Supply and replace sixty-four (64) wheel assemblies for the SR inclusive of wheels, bearings and shaft.</p> <p>For all bogies and wheels – Refer drawings 700399, 700403, 700404, 700405, 700406, 700407, 700449, 700459, 700460, 700527</p>	Sum	Mechanical	Item no. 1, 2, 33
9	<p>Centralised Automatic Lube System</p> <p>Refurbish entire lubrication system (Slew Bearing, Travel Bogey & Pivot, Bucket Wheel, Tripper Car)</p> <p>For further information, refer to document "SR3 Lubrication system", Annexure 21</p>	Sum	Mechanical	Item no. 9, 27
10	<p>Travel Brakes</p> <p>Supply and replace thirty-two (32) travel brakes Drive unit - 7.5kW For further information, refer to drawing 700404</p>	Sum	Electrical	Item no. 13, 14
11	<p>Slew Drive Assembly</p> <p>Replace the three (3) complete slew drives (including alignment), inclusive of drives, shafts, gearboxes, motors, reducers and pinions, and spillage covers for the motors. These will be free issued.</p> <p>Also supply three (3) new complete slew drives (including alignment), inclusive of drives, shafts, gearboxes, motors, reducers and pinions, and spillage covers for the motors, as spares.</p> <p>For further information, refer to drawings 700418, 700421, 700422, 700425, 701650</p>	Sum	Structural Mechanical Electrical	Item no. 1, 3 Item no. 21-29 Item no. 7
12	<p>Set of Weather Protection Enclosures</p> <p>Weather protection enclosures e.g. weather proof outdoor crates must be supplied to store the following components of a spare bucket wheel: motor, bucket wheel chute, bearings, and plumber blocks. The enclosures will be stored in an outdoors open area assigned by BTS at the terminal's stores.</p>	Sum	Structural Mechanical	Item no. 6 Item no. 19, 20



EQUIPMENT REFIT PROJECT (PHASE 4)				
STACKER RECLAIMER 3				
Item	DESCRIPTION	Sum	WCS Report	Report Item No.
13	<p>Hose Reel</p> <p>Supply and replace the complete hose reel including the VSD, funnel system and hose.</p> <p>Hose Reel to be of 3:2:3 configuration.</p> <p>Include for Midpoint sump upgrade (Pump, Cage/Civils, piping as per SR1 and SR2).</p> <p>For further information, refer to Refer to drawing: A4870000.</p>	Sum	Mechanical	Item no. 37
14	<p>Operator Cab (Stainless steel Cab)</p> <p>Replace the existing operator cabin with a new larger stainless-steel cabin with space to allow for main chair and ordinary training chair. Any additional supporting structure required must be included. The Levelling System must also be refurbished.</p> <p>A detailed engineering design must be issued to the Project Manager for acceptance prior to start of manufacturing of the operator's cabin.</p> <p>For further information, refer to document Annexure 22, "Cabin Refurbishment 12092018" and Annexure 23, "Technical Spec Operator's Cab", and the current Cabin Drawings 700451, 700452 1-4.</p> <p>The New Operator's Cab must consist of a Stainless-Steel Exterior and meet the following specifications and requirements:</p> <ul style="list-style-type: none"> The cab shall be designed to mount on the existing cab support. The existing cab support structure to be water blasted and inspected after removal of the existing cab. Allowance should be made for possible structural replacements, and corrosion protection, new SS bolts, washers, and other miscellaneous items for installation of the new SS cab. The cab shall have a unitized frame consisting of structural tubing. Four (4) lifting lugs shall be incorporated into the top of frame. The floor shall be framed in 4" x 6" tubing, the walls 2" x 4" tubes with 4" x 4" tubes at the corners and door frames. The outside skin shall be 11-gauge stainless steel, commercial quality flat sheets. All seams shall be continuously welded to the structural frame. All seams between plates shall be continuously welded to form a waterproof surface. Upon completion of the welding process, the surface shall be finished with a random brushed pattern (no paint on the exterior skin). Roof shall be designed for a 4.7880259 kPa live load. The inside skin shall be carbon steel, commercial quality flat sheets. Sheets shall be mechanically fastened to the structural frame. Interior floor covering shall be smooth plate, plug welded to the floor frame. 	Sum	Structural Electrical	Item no. 1 Item no. 11,



EQUIPMENT REFIT PROJECT (PHASE 4)

STACKER RECLAIMER 3

Item	DESCRIPTION	Sum	WCS Report	Report Item No.
	<ul style="list-style-type: none"> • Floor covering shall be an Industrial Grade rubber matt at least 3.175mm thick. • The floor shall have wire-ways with removable covers installed for electrical wiring. The wire-ways shall at a minimum interconnect the operator's chair, the cab distribution panel to a NEMA 4X junction box mounted on the outside of the cab. • The cab shall be fully insulated. • Windows shall be fixed type, insulated windows. The windows shall be removable from the interior. All windows shall be sealed and caulked prior to shipment. • The door shall have at least a 1-3/4" thick panel, 24-gauge pre-painted galvanized steel skin, 16-gauge pre-painted galvanized steel jambs, 4" x 4" stainless steel NRP hinges, full perimeter weather stripping, thermal break of header/threshold to prevent ice build-up on threshold, thermal break of panel and jambs to prevent frost build up in interior of cabin. The jamb shall be mechanically fastened to the structural frame. The door shall include an insulated tempered glass window, automatic door closer and standard lockset with lever handles. • The cab shall incorporate an operator's chair with integrated controls and a trainee chair. • Operator's chair shall be mounted in the cab. The chair shall have controls that are currently located in the cab consoles integrated into the arm consoles. The new controls will be prewired to terminals in a new cab junction box. • At a minimum once the Work is complete the cab and controls shall perform as per the original design and performance specifications. • The operator's cabin must be equipped with an HMI which shall be mounted near the operator on articulating arms to be adjustable to the needs of the various operators. • The cab shall have a 100A, 230 single phase distribution panel, equipped with four 20A duplex receptacles and capacity for 20 circuit breakers. • Cab shall have a switch operated ceiling light. • HVAC system shall be designed to maintain a temperature inside the cabin of between 66- and 78-degrees Fahrenheit (18.89- and 25.56-degrees Celsius), irrespective of the ambient temperature. The Operator must be able to set the desired cabin temperature. The ambient temperature range is -10 to 105 degrees. • The cab shall have a combination HVAC system. • The cab shall have a windshield wiper and washing system. • The cab shall be painted in accordance with Transnet Specifications. 			



EQUIPMENT REFIT PROJECT (PHASE 4)				
STACKER RECLAIMER 3				
Item	DESCRIPTION	Sum	WCS Report	Report Item No.
	<ul style="list-style-type: none"> The cab shall incorporate an operator's chair which must be as per the specification under Item 14 below and priced separately under Item 14 on the Pricing data Sheet. 			
15	<p>Operators Chairs</p> <p>A total of two (2) new operator chairs must be provided. Of these, one must be installed in the new operator's cabin of SR3 specified under Item 14 above and one chairs must be provided as a spare.</p> <p>In addition, two (2) complete sets of spares are to be supplied.</p> <ul style="list-style-type: none"> The operator's cabin shall incorporate an operator's chair with integrated controls. The installation and commissioning of the chair must be included. The operators chair to meet the following requirements: <ul style="list-style-type: none"> Ergonomic operators chair with integrated controls and equipped with the following features: <ul style="list-style-type: none"> Full body contoured seat with replaceable cushions and dual slides Fore and aft adjustment range +/-4" each slide Independent back rest and seat height adjustments 80-degree adjustable back rest for reclining Seat cushion tilt adjustment 3-11 degrees to reduce thigh pressure Seat cushion depth adjustable forward 2.4" in 5 increments to accommodate larger operators. Manually adjustable armrest Console mounted adjustable armrest All new pushbuttons, selector switches, pilot lights, master switches and potentiometers wired to terminal blocks inside the new chair mounts control consoles <p>The chair shall be easily adjustable in terms of moving it forwards and backwards so that each operator can position the chair</p> 	Sum		

EQUIPMENT REFIT PROJECT (PHASE 4)				
STACKER RECLAIMER 3				
Item	DESCRIPTION	Sum	WCS Report	Report Item No.
	<p>according to their personal preference so that they don't need to sit on the edge of the chair.</p> <p>It shall be constructed under ISO 9001 quality standard.</p> <p>The following materials will be used; Sheet steel DC01, DD11 or equal - Steel profiles S235JR or equal - Stainless steel 304</p> <p>The operator seat shall include:</p> <ul style="list-style-type: none"> - Rotation table for rotating seat - Heavy duty bearing - Locking device for one fixed position - Black leather upholstery - 3-Point seatbelt - Consoles with left- and right-hand side, rotatable and tiltable. - A USB mini-joystick (1 piece) to be provided on the right-hand console in place of the track ball with 3-Axis (4 directions + rotation knob), open coulisse, 2 pushbuttons on top of lever and USB output. - The design of the cabin and its mounting must be approved by an appropriate professional engineer. 			
16	<p>S/R T Bar Festoon</p> <p>Supply and replace S/R T Bar Festoon with new system.</p> <p>Festoon system to include all festoon curved tracks, support brackets, cable trolleys, festoon cables, tow chains, and junction boxes.</p> <p>For further information, refer to document "Technical Spec Tow Bar Festoon", Annexure 24</p>	Sum	Electrical	Item no. 19-23
17	<p>Slew Cable Carrier</p> <p>Supply and install grating and replace drag chain with festoon and canopy.</p> <p>For Further information, refer to drawings:</p> <ul style="list-style-type: none"> - 639-18694-B2_Rev0 - Presentation-Circular festoon 	Sum	Electrical	Item no. 41
18	<p>Main Power Cable Reel</p> <p>Supply and replace Main Power Cable Reel with new system.</p> <p>For Further information, refer to document "Main Power reel", Annexure 25</p>	Sum	Electrical Mechanical	Item no. 24-27 Item no. 36
19	<p>Slew Drive VFD's</p>	Sum	Electrical	Item no. 4, 5, 6, 34-36



EQUIPMENT REFIT PROJECT (PHASE 4)				
STACKER RECLAIMER 3				
Item	DESCRIPTION	Sum	WCS Report	Report Item No.
	Supply and replace Slew Drive VFD's (complete set) with new complete Slew Drive VFD assembly (Active Front End). For Further information, refer to document "Technical Spec Slew VFD's & SR3 VFD's"			
20	Travel Drive VFDs Supply and replace Travel Drive VFDs with new complete Travel Drive VFD assembly For Further information, refer to document "Technical Spec travel VFD's & SR3 VFD's"	Sum	Electrical	Item no. 4, 5, 6
21	Bucket wheel VFD Replace Bucket Wheel Drive VFD assembly with new set. For Further information, refer to document "Technical Spec Bucket Wheel VFD's & SR3 VFD's"	Sum	Electrical	Item no. 4, 5, 6
22	VFD spares Supply the following VFD spares: <ul style="list-style-type: none"> One (1) set for Bucket Wheel VFD Two (2) sets for Slew Drive One (1) set for Travel Drive For Further information, refer to document "SR3 VFD's"	Sum	Electrical	Item no. 4, 5, 6, 34-36
23	Main PLC Utilise the existing enclosure. Supply and replace the main PLC with a new PLC including the following: <ul style="list-style-type: none"> One (1) Siemens or equivalent PLC system with all the necessary power supplies, processor, I/O, communications modules, and customer terminal blocks, required to replace the existing PLC that is currently installed One (1) door mounted HMI computer/display All the other miscellaneous relays, terminals, wiring, nameplates, and all other components. Everything needed to supply power to the enclosure contents. Door switch operated LED light fixture and duplex outlet. 	Sum	Electrical	Item no. 37-40

EQUIPMENT REFIT PROJECT (PHASE 4)				
STACKER RECLAIMER 3				
Item	DESCRIPTION	Sum	WCS Report	Report Item No.
24	<p>Corrosion Protection (SR and Tripper car)</p> <p>Corrosion protection, as per corrosion protection paint specification, to be applied to all corroded areas of the Stacker Reclaimer 3 and Tripper Car. Contractors to allow for 350 square meters corrosion protection, to be re-assessed on site.</p> <p>The Boom Tip to be excluded.</p>	Sum	Structural	Items no. 1, 2, 9, 11
25	<p>Shipping Containers</p> <p>Supply Six (6) 12ft shipping containers to be supplied to house spares</p>	Sum	Mechanical	Items no. 41
26	<p>Structural/weld repairs/NDT's of critical areas/Bolt replacement, excluding the Boom Tip</p> <p>NDT's to be taken of the boom as per Drawing 'NDT Requirement' Allow for eighty (80) full penetration weld repairs.</p> <p>Structural Repairs to be done as per WCS Structural Report.</p> <p>Make an allowance for the supply and replacement of 200 bolts with specification of hex bolt DIN 931, grade 10.9, M20x2.5x100. The inspection certificates for these bolts must be provided.</p> <p>Allow for average plate thickness of 20mm.</p> <p>Allow for weld length of 400mm.</p> <p>Include all labour and equipment needed to execute these works.</p> <p>Procedure to be followed:</p> <ul style="list-style-type: none"> • Clean area with high pressure water & brush to bare metal. • Visual Inspection. • Wall thickness testing. (UT) • Crack testing. (MPI) • Assess and determine repair scope. (Area under compression or tension) • Prepare WPS for weld repairs. • Submit repair procedure for client approval. • Perform repair as per approved procedure. • NDT testing to confirm acceptance. • Release for corrosion protection. <p>Refer to drawing: NDT Requirement. Refer to WCS Structural Report for all structural repairs.</p>	Sum	Structural	Item no. 1, 2, 3, 4, 5, 8, 9, 10, 13, 14, 15. Note 1 & 3
27	<p>Boom Conveyor Drive Train set</p> <p>Replace existing Boom Conveyor Drive Train set. Supply and install a complete Boom Conveyor Drive Train set.</p> <p>A set will include two motors, with two gearboxes and the couplings.</p> <p>Refer to drawings: Boom Conveyor Drive</p>	Sum	Mechanical Electrical	Item no. 5-8 Item no. 8

EQUIPMENT REFIT PROJECT (PHASE 4)				
STACKER RECLAIMER 3				
Item	DESCRIPTION	Sum	WCS Report	Report Item No.
28	<p>Boom Conveyor Drive Train sets</p> <p>Supply two (2) complete Boom Conveyor Drive Train sets as spare.</p> <p>A set will include two motors, with two gearboxes and the couplings.</p> <p>Refer to drawings: Boom Conveyor Drive</p>	Sum	Mechanical Electrical	Item no. 5-8 Item no. 8
29	<p>Incline Conveyor Drive Train set</p> <p>Replace existing Incline Conveyor Drive Train set. Supply and install a complete Incline Conveyor Drive Train set.</p> <p>A set will include two motors, with two gearboxes and their couplings.</p> <p>Refer Drawings: Incline Conveyor Drive</p>	Sum	Mechanical Electrical	Item no. 5-8, 35 Item no. 8
30	<p>Incline Conveyor Drive Train sets</p> <p>Supply two (2) complete Incline Conveyor Drive Train set as spare.</p> <p>A set will include two motors, with two gearboxes and their couplings.</p> <p>Refer Drawings: Incline Conveyor Drive</p>	Sum	Mechanical Electrical	Item no. 5-8, 35 Item no. 8
31	<p>Boom and Incline Conveyor Drive Pulleys set</p> <p>Supply and install one (1) set.</p> <p>A set will include one boom drive pulley and one incline drive pulley.</p> <p>Refer Drawings: Drive Pulley IC Model Incline & Drive Pulley BC Model Boom</p>	Sum	Mechanical	Item no. 11
32	<p>Boom and Incline Conveyors Drive Pulleys sets</p> <p>Supply two (2) sets as spares.</p> <p>A set will include one boom drive pulley and one incline drive pulley.</p> <p>Refer Drawings: Drive Pulley IC Model Incline & Drive Pulley BC Model Boom</p>	Sum	Mechanical	Item no. 11
33	<p>Simocode Modules in the Gantry MCC</p> <p>Supply and replace all the existing obsolete Simocode Modules in the Gantry MCC with new Simocode Pro V units or similar.</p>	Sum	Electrical	Item no. 37-40
34	<p>Replace Air conditioning within Gantry E-House, Extend/Seal Roof and relocate Condenser</p> <p>Air conditioning units to meet following specifications:</p> <p>E-House: 2 x 60,000 BTUS (3PH/400v)</p> <p>Slew deck: 2 x 36,000 BTU (1PH/220v)</p>	Sum	Electrical	Item no. 4, 5, 6

EQUIPMENT REFIT PROJECT (PHASE 4)				
STACKER RECLAIMER 3				
Item	DESCRIPTION	Sum	WCS Report	Report Item No.
	Seal the E-House roof for water ingress and extend by 1m to protect local control station. The gantry E-House Condenser must be relocated to an area that is not subjected to falling material when the SR is in operation.			
35	Operators Fire Escape Install a fire escape point to the operator's cabin. Insert connection/anchor point onto cabin platform as per SR2 considering the loads and structural support required.	Sum		
36	Refurbish Dust Suppression System The Dust Suppression System to be refurbished with a new pump. For Further information that need to be complied with, refer to the document "Dust Suppression Scope".	Sum	Mechanical	Item no. 40
37	Replacement of Local Maintenance Stations / Calipers / Chains Include for replacement of seven (7) local maintenance pushbutton stations. Include replacement of the calipers and chains used for lockouts.	Sum	Electrical	Item no. 32 & 33
38	HT Switchgear power relays (set) Supply and replace all power relays with new relays. Set of six (6). Refer to C & I Condition Assessment Report, Annexure 13	Sum	Electrical	Item no. 12

4.4 Site related items to be supplied with responsibility for providing

The table below lists site related items to be supplied and the party responsible for their supply. Note, this list may not be exhaustive, and any additional items required will be assumed to be for the Contractor to supply and must be allowed for in his tender price.

ITEM DESCRIPTION	SLD: IOT/CLIENT SUPPLY	PRINCIPLE CONT. SUPPLY
Client special & task specific PPE requirements		X
Suitable Accommodation and meals for the Site Crew		X
Permits from DOL for working overtime, Sundays, and extended hours		X
Application to DOL for permit to Execute the Works. Contractor to supply required documentation.	X	X
Provide a suitable area for Site Establishment	X	
Supply of water within 50m from Site Yard	X	

ITEM DESCRIPTION	SLD: IOT/CLIENT SUPPLY	PRINCIPLE CONT. SUPPLY
All Containers and Mobile Offices/Eating- & Ablution Facilities for all Contractors' Workforce.		X
Supply Mobile Office for TPT/CMC Team (6 workstations with chairs).		X
Power Supply (220V and 380/525V) within 50 m of point of Work. Contractor to supply cable and distribution board for welding and 220V. Contractor to complete installation and provide COC. Contractor to provide backup generator in the event of power disruptions	X	X
Contractor to provide power in the event of a power failure. Standby generator to be provided.		X
Adequate area lighting for safe execution of work during night shifts		X
Compressed Air within 50m from point of work		X
Containers for the disposal of scrap metal, cleaning tags and other waste materials in demarcated area. (Contractor responsible for correct sorting of waste and Client for disposal/removing from site).	X	
Remove all components which were replaced with new/refurbished components to the identified laydown area		X
All Support structures (inclusive of load testing and engineers sign-off), barricading, safe access, signage, and scaffolding required.		X
All lubrication requirements, on existing equipment, outside of the Contractors scope (Oil, grease etc. as per OEM Specification).	X	
All new and refurbished components to be delivered fully lubricated/filled with oil and ready for commissioning after installation.		X
Responsibility for conveyor belt cutting/splicing.		X
Fire extinguishers, radios and other items required for Commissioning		X
Cleaning of Machine of all excess material and other debris		X
Qualified Operator available as and when required (24-hour notification required from Contractor)	X	
All fencing around Contractor's site yard and lay down areas, traffic control with signage/ flagmen and security control.		X
All Lock-out equipment: Locks, calibres, and tags (Contractor & Client to provide own)	X	X
Existing conveyors, medium voltage cable, cable racks etc. to be protected from the construction works and when hot work is done.		X

4.5 Construction / Execution / Commissioning

The *Contractor* is to ensure that aspects applicable to construction / execution process, as described in the Commissioning Plan, Annexure 26 are included.

4.6 Method Statements

Method Statements to be prepared for all major activities to be executed on site, as identified by the *Contractor*. These method statements shall include detailed Risk Assessment, with planned mitigations to ensure safe execution, using the correct Equipment, Tools and Competent and well-trained Workforce. To be submitted with the tender documentation.

Note to tenderers:

Method statement - The tenderers must sufficiently demonstrate the approach/methodology that he/she will employ to cover the scope of the project.

5 List of Drawings

5.1 As-Built Drawings

The *Contractor* must submit as-built drawings to the Employer on completion of the Works.

5.2 Drawings issued by the *Employer*

The following list of drawings applicable to the Works will be issued by the *Employer* at or before the start Contract Date. Some drawings may contain both Works Information and Site Information.

Drawings - Bucket Wheel & Chute

- 5M6143714d
- 700454C
- 700455_D_1-5
- 700456_B_1-2
- 700457_C_1-8
- 701192_A_1
- 707320_A_1

Drawings - Conveyor Drive Trains Pulleys

- Boom Conveyor Drive
- DRIVE PULLEY-BC-Model Boom
- DRIVE PULLEY-IC-Model Incline
- Incline Conveyor Drive

Drawing - Hose Reel

- A4870000-SR02Cable-200911

Drawings - Idler Support Frames

- 700432_C_1-6
- 700464_E_1-3
- PTP031_15_0842_001
- PTP031_15_0843_001
- PTP031_15_0844_001

Drawings - Operators Cabin

- 700451_B_1-5
- 700452_A_1-4
- 700452_A_2-4
- 700452_A_3-4
- 700452_A_4-4

Drawings - Slew Cable Carrier Festoon

- 639-18694-B2_Rev0
- Presentation-Circular festoon

Drawings - Slew Drive Reducers

- 700418_E_1-17
- 700421_A_1
- 700422_E_1-5
- 700425_B_1-2
- 701650_B_1

Drawing - Travel Brakes

- 700404_B_1

Drawings - Wheels for SR



- 700399_B_1-3
- 700403_C_1-2
- 700404_B_1
- 700405_B_1
- 700406_B_1
- 700407_B_1
- 700449_B_1
- 700459_A_1
- 700460_C_1-3
- 700520_B_1
- 700527_A_1

6 List of Annexures

6.1 Annexures issued by the Employer

6.1.1 This is the list of annexures issued by the Employer at or before the Contract Date and which apply to this contract.

Annexure	Document Name	Document Description
1	Contractor Documentation Submittal Requirements	DOC-STD-0001 Rev.03
2	Health and Safety Management Plan	Z.5200160 - HSMP
3	Environmental Baseline Report	Z.5200160 - EBR
4	Environmental Risk Report	Z.5200160 - ERR
5	Commissioning Plan	Z.5200160 - CP
6	Quality management plan	Z.5200160 - QMP
7	Construction Management Plan	Z.5200160 - CMP
8	Security Management Plan	Z.5200160 - SMP
9	Communication Management Plan	Z.5200160 - CMR
10	TIMS - Contractor Environmental and Sustainable Specification Guideline	TRN-IMS-GRP-GDL-014.4
11	TIMS - Contractor Health and Safety Specification Guideline	TRN-IMS-GRP-GDL-014.3
12	TIMS - Contractor Quality Specification Guideline	TRN-IMS-GRP-PROC-GDL 014.6
13	SR3 E, C & I Condition Assessment	WCS Report
14	SR3 Mechanical Condition Assessment	WCS Report
15	SR3 Structural Condition Assessment	WCS Report
16	Dust Suppression Scope	SR1 & SR3 Work Specification
17	SR3 VFD's	400V Systems for Travel Drives, Slew Drives and Bucket Wheel
18	Technical Spec Bucket Wheel VFD	Technical Specification (Stacker Reclaimer 2)
19	Technical Spec Slew VFD's	Technical Specification (Stacker Reclaimer 1)

Annexure	Document Name	Document Description
20	Technical Spec Travel VFD's	Technical Specification (Stacker Reclaimer 1)
21	SR3 Lubrication System	Lubrication System Scope
22	Operators Cabin - Cabin Refurbishment 12092018	Operations Requirements
23	Operators Cabin - Technical Spec Operator's Cab	Technical Specification (Stacker Reclaimer 1)
24	Technical Spec Tow Bar Festoon	Technical Specification (Stacker Reclaimer 1)
25	Main Power Reel	Detailed Scope – Stacker Reclaimer 2 - Supply Cable Reel
26	Commissioning Plan	Z.5200160-CP

6.1.2 Standard Transnet Specifications

Document Name	Document Description
Quality Management	EEAM-Q-009
Gen Electric Equipment	EEAM-Q-012
Commissioning	EEAM-Q-013
General Requirements and Conditions	EEAM-Q-016
Tests on Electrical Equipment	EEAM-Q-020
Electronic Equipment	EEAM-Q-021
Belt Conveyors and Assoc Equipment	EEAM-Q-001
Specification – Hydraulic Equipment	EEAM-Q-002
Structural Steelwork	EEAM-Q-006
Corrosion Protection	EEAM-Q-008
Gears–Shafts–Bear–Brakelube-V Belts	EEAM-Q-004

SECTION 2

7 Management and start up

7.1 Management meetings

Regular meetings of a general nature may be convened and chaired by the *Project Manager* as follows:

Meetings during execution phases:	Frequency	Attendance by:
Daily coordination, feedback and planning meeting	Daily	Teams from TPT, CMC, TPT Client and Contractor
Weekly SHE Meetings	Weekly	CMC, Project Manager, Contractors Management Teams, Client Team
SHE Pre-mobilisation Meeting (Once-off)	Within one Week prior to site establishment by Contractor and his sub-contractors.	CMC, Project Manager, Contractors Management Teams, Client Team
Site Handover meeting (Once-off)	On completion of Site Establishment.	CMC, Project Manager, Contractors Management Teams, Client Team
Meetings during commissioning phases:	Frequency	Attendance by:
Daily coordination and planning meeting	Daily	Commissioning teams from TPT, CMC and Contractor

All meetings will take place at the Port of Saldanha premises except for cases where arrangements have been made to conduct the meetings via telecon. It is a requirement that the *Contractor* provide the scribe for these meetings. All the necessary costs associated with these meetings and taking of minutes (inclusive of distribution and document control) must be part of the Preliminaries and Generals cost.

Meetings of a specialist nature may be convened as specified elsewhere in this Works Information or if not so specified by persons and at times and locations to suit the Parties, the nature, and the progress of the *works*. Records of these meetings are to be submitted to the *Project Manager* by the person convening the meeting within five days of the meeting.

All meetings are to be recorded using minutes or a register prepared and circulated by the person who convened the meeting. Such minutes or register are not to be used for the purpose of confirming actions or instructions under the contract as these are to be done separately by the person identified in the *conditions of contract* to carry out such actions or instructions.

7.2 Documentation control

In undertaking the '*Works*' (including all incidental services required), the *Contractor* shall conform and adhere to the requirements of the 'Contractor Documentation Submittal Requirements' Standard included in Annexure 1 (refer DOC-STD-0001).

The *Contractor* is to ensure that the latest versions of the required application software and a suitable 'IT' Infrastructure are in place to support the electronic transmission of documentation.

All electronic submissions that are submitted via email to be submitted to wcdoccontrol@transnet.net

7.3 Safety risk management

- 7.3.1 The *Contractor* is to comply with the Health and Safety Specification and Health and Safety Management Plan. Refer to Annexure 11, TIMS - Contractor Health and Safety Specification Guideline.
- 7.3.2 The *Contractor* ensures that its Subcontractors comply with the requirements of the Health and Safety Specification and Health and Safety Management Plan.
- 7.3.3 The *Contractor* to compile a Health and Safety Plan to cover all SHEQ legislative- and other legal requirements. Health and Safety Plan to be submitted with tender, for approval by *Employer* and *Employer's* appointed Health and Safety Agent.
- 7.3.4 *Contractor* to prepare a detail HAZOP study and Site/Task Specific Risk Assessment (HIRA), prior to carrying out any operation on the Site and/or Working Area to the approval of *Project Manager*. Refer to Annexure 11, TIMS - Contractor Health and Safety Specification Guideline.
- 7.3.5 *Contractor's* Health & Safety Plan, method statements, HAZOP & HIRA studies and other documentation required, to be approved by *Employer*.
- 7.3.6 *Contractor* to obtain timely approval, from the Department of Labour to work extended working hours.
- 7.3.7 *Contractor* to provide proof of "Medical Fitness" and "Training Certification" for all employees. All *Contractor's* and Subcontractor's personnel working on Site are required to undergo medical and drug tests.
- 7.3.8 Prior to site establishment all the *Contractor's*- as well as all Sub-Contractor's employees will undergo a Health and Safety induction course and other required safety training.
- 7.3.9 The *Contractor* performs the *works* having due regard to the HSSP.
- 7.3.10 The *Contractor* complies with the requirements of the SSRC with respect to his own activities and others on the Site and Working Areas.
- 7.3.11 The *Contractor* makes the Health and Safety Specification and Health and Safety Management Plan available to its employees and Subcontractors in the *language of this contract* and other local languages as required.
- 7.3.12 The roles and responsibilities of the various personnel acting on behalf of the *Project Manager* with respect to health and safety issues are as stated in the paragraphs following:
- 7.3.13 The *Contractor* shall provide a full time Safety Officer on Site and in Working Areas who will cover all activities including overtime and weekend work. Proof of valid SACPCMP registration as Construction Health and Safety Officer is a requirement for all the construction safety officers that will be assigned to the project. The valid certificates must be submitted before any site activities commence and the validity must be maintained throughout the period/s that any work is undertaken on site.
- 7.3.14 The *Contractor* shall transport personnel in a safe manner from the access boom to the Site. Walking between the main entrance gate and the Site is prohibited. No transport of employees on the back of an open LDV or vehicle is allowed.
- 7.3.15 No alcohol is permitted on Site and Transnet property. The Employer has zero tolerance on Site. Employees found under the influence will be removed from Site and will not be allowed on Site again.
- 7.3.16 All Equipment, cranes and Plant is to be inspected by the *Employer* before commencement of work.
- 7.3.17 Constant supervision is required on Site during execution of works. The presence of appointed supervision is therefore always required on Site.

7.4 Environmental constraints and management

- 7.4.1 In undertaking the *works* (including all incidental services required), the *Contractor* is to fully comply with all the requirements of the documents listed below including the development and implementation of any required Environmental Management Plan (EMP) or Environmental Method Statements (EMS).

- Environmental Baseline Report
- Environmental Risk Report

7.4.2 The *Contractor* shall ensure that his management, foremen and the general workforce, as well as all suppliers and visitors to Site have attended the BTS Induction Program, prior to commencing any *work* on Site. If new personnel commence work on the Site during construction, the *Contractor* shall ensure that these personnel undergo the Induction Programme and are made aware of the environmental specifications on Site.

7.5 Quality assurance requirements

7.5.1 In undertaking the *works* (including all incidental services required), the *Contractor* is to follow the requirements of the items listed below.

7.5.2 The *Contractor* shall execute the works in accordance with the requirements of the Quality Management Plan.

7.5.3 The *Contractor* submits his Quality Management System documents to the *Project Manager* as to include details of:

- Quality Plan for the contract
- Quality Policy
- Index of Procedures to be used
- A schedule of internal and external audits during the contract
- A Typical Quality Control Plan (QCP) (for each task)
- Typical data book index

7.5.4 Due consideration must be given to the deliverables required to execute and complete the contract as per ISO 9001 Quality Management Standard.

7.5.5 The *Contractor* is to provide QCP's and Method Statements for all scope items to the Project Manager and CMC, for review and approval, at least one week prior to the execution of the *works*.

7.5.6 The *Contractor* is to provide QCP's and quality checklists for refurbishment items/components being manufactured off site, as per the discretion of the Project Manager.

7.5.7 The *Contractor* develops and maintains a comprehensive register of documents that will be generated throughout the contract including all quality related documents as part of its Quality Plan.

7.5.8 The *Contractor* shall provide a suitably qualified full-time dedicated resident Quality Manager for all aspects of the works including Site activities, with a staff adequate to perform the requirements of his Quality Plan and Quality Management System.

7.5.9 The *Contractor* is to notify the CMC Quality Manager for inspections at least 24hrs in advance.

7.5.10 The nominated individual shall be fully conversant with quality management on major construction projects and the maintenance of an appropriate ISO 9001 Quality Management System or accepted equivalent. The Contractor shall submit the CV of his quality manager to the Project Manager, for review, complete with a proposed organogram clearly indicating reporting levels and the number of resources dedicated to quality assurance and quality control.

7.6 Programming constraints

7.6.1 The *Contractor* shows on each programme he submits to the *Project Manager*, the requirements of the project requirements including, H&S, environmental, quality, construction etc.

7.6.2 The *Contractor* shows on each programme he submits to the Project Manager, the requirements, as well as the order and timing of all operations and refurbishment activities.

7.6.3 The *Contractor* presents his first programme and all subsequently revised programmes (see NEC3 ECC Clauses 31.2 and 32.1) in hard copy format and in soft copy format. (Both in PDF and MS Projects format).

7.6.4 The *Contractor* shall appoint a full-time planner, with adequate relevant experience to perform the requirements as specified. The appointed planner shall be fully conversant in planning on major construction projects and have a full understanding and knowledge of the *works* and *logic*, to plan the *works*.

- 7.6.5 The *Contractor* uses MS Project for his programme submissions.
- 7.6.6 The *Contractor* shows on his Accepted Programme and all subsequently revised schedules, the critical path or paths and all necessary logic demonstrating sequence of operations.
- 7.6.7 The *Contractor's* programme shows duration of operations in working days and shall be realistic and based on quantities and applied resources. The calendars used are based 24 hours, 7 days operation or as prescribed by the *Project Manager*.
- 7.6.8 The *Contractor's* schedule/programme shall be structured in such a manner to be able to show the following levels:
- Level 1 Master Schedule – defines the major operations and interfaces between engineering design, procurement, fabrication and assembly of Plant and Materials, transportation, construction, testing and pre-commissioning, commissioning, and Completion.
 - Level 2 Project Schedule – summary schedules 'rolled up' from Level 3 Project Schedule described below
 - Level 3 Project Schedule – detailed schedules generated to demonstrate all operations identified on the programme from the starting date to Completion. The activities will be assigned a code and there will be heading describing the works to be performed. The *Project Manager* notifies any subsequent layouts and corresponding filters on revised programmes.
 - Level 4 Project Schedule – detailed discipline speciality level developed and maintained on daily basis by the *Contractor* relating to all operations identified on the programme representing the daily/hourly activities by each discipline. This schedule to cover 3-day look-ahead activities and to be submitted to PM on daily basis.
- 7.6.9 The *Contractor* shows on each revised programme he submits to the *Project Manager* a resource histogram showing planned progress versus actual, deviations from the Accepted Programme and any remedial actions proposed by the *Contractor*.
- 7.6.10 The *Contractor* to submit a, daily, high level schedule report at the end of the dayshift, covering progress on all activities for the past 24 hours and clearly indicated the items that running late and are behind schedule and planned actions to get these items back on schedule. This high-level action schedule will be discussed in the daily morning meetings
- 7.6.11 The *Contractor* submits schedule/programme report information to the *Project Manager* at weekly intervals, or as per request from the *Project Manager*.
- 7.6.12 The *Contractor's* weekly programme narrative report includes:
- Status report - narrative which includes status and performance of operations on the site and Working Areas; summary of progress achieved during the reporting period; status and performance of operations outside the Working Areas; critical action items (top 10) and deviations from the Accepted Programme and action plan to rectify.
 - Progress statistics - progress as a percentage of overall works and show progress for "this period" and "progress to date". To calculate this percentage the Contractor uses a spreadsheet to calculate earned progress of on activities which have been weighted using man-hours.
 - Project milestone table - reflecting previously and currently forecasted versus accepted milestones.
 - Level 4 Project Schedule - showing the current forecast dates base-lined against the latest Accepted Programme and showing both a Total Float and Variance column.
 - Weekly look-ahead Schedule - showing the current forecast dates base-lined against the latest Accepted Programme and showing both a Total Float and Variance column.
 - Manpower Histogram - reflecting actual, forecasted and planned activities.
 - S-curves - reflecting the actual percentage complete versus the planned percentage for the overall contract utilising the earned values as calculated by the detailed progress report.
- 7.6.13 The *Employer* (including the agents of the Employer) operates on Site 24-hours per day, 7 days per week
- 7.6.14 *Employer's* schedule
- The *Employer* requires execution to be aligned to the Sept/Oct Annual Industry Iron Ore Shut period and the utilisation of available maintenance windows by the *Contractor* leading up to the Shut period. Maintenance windows are normally weekly 12-hour slots which may or may not be confirmed by the *Employer* a week prior depending on operational and technical priorities of the



Terminal. Therefore, the *Contractor* to plan batches of work that can be started and completed within a 12-hour window as far as possible with prior agreement with the *Employer*.

- 2024 Execution period (5 weeks: 1 Sep – 6 Oct 2024*)
- 2025 Execution period (5 weeks: 1 Sep – 6 Oct 2025*)

The following is applicable to the project plan:

2024 Shut Period Execution Schedule

Site access/establishment for shut period	15 August 2024*
Start of execution of Scope of Works	1 September 2024*
Completion of scope or works with handover to operations for hot commissioning	1 October 2024*

2025 Shut Period Execution Schedule

Site access/establishment for shut period	15 August 2025*
Start of execution of Scope of Works	1 September 2025*
Completion of scope or works with handover to operations for hot commissioning	1 October 2025*

Note: *Dates subject to change

7.6.15 *Contractor's* schedule (returnable)

The *Contractor* is to prepare and submit together with this tender, a Level 2 schedule, for a 24 hour / 7 days' work week. The *Contractors* schedule is to be aligned to the *Employers* information listed in the section above.

The schedule to make provision for the following for each of the two shut periods:

- 2-week site establishment period.
- Pre, Cold and Hot commissioning on completion of the work shown in the schedule.

A detailed Level 4 schedule to be submitted at execution, which show all necessary links/critical path, to be updated daily during shut execution period.

7.7 Contractor's management, supervision and key people

7.7.1 The *Contractor* is to submit a detailed resource plan to cover the following:

- Organogram showing the entire planned site team, including the Sub-Contractors, with line of reporting, covering all disciplines.
- Commissioning Plan including organogram, names with qualification and legal appointments; proposed commissioning schedule indicating preparation for commissioning and close out.
- List and detail on all Sub- and Specialist Contractors planned to be utilised for the project. Also indicate planned/intended SOW of these sub-contractors, size of workforce, with timeframe of involvement.
- Human Resource Management plan. *Contractor* to provide a comprehensive Human Resource Management plan to cover all industrial relations (IR) and human resource (HR) activities.
- *Contractor* to indicate and confirm that the management team, supervisory, and execution team allocated for this project will be dedicated to this project only and will not be involved with any other work during the same time as this project. Any dual responsibilities by any of the team members, with any involvement on any other work during the shut execution, must be clearly indicated.
- List of all equipment, crantage, vehicles, tools, site infrastructure and others.

- 7.7.2 The *Contractor* is to submit a comprehensive and detailed organogram that shows the structure and composition of their management structure involved in the *works*, inclusive of the key staff/professionals.
- 7.7.3 The *Contractor* to assign well qualified personnel as listed in the table below who have the necessary skills, experience and qualifications required to carry out the services identified in this Scope of Works.

Key Person Role	Requirement
	More experience than indicated below will translate in a higher score during tender evaluations.
Project Manager	Proof of valid SACPCMP registration for either the Project Manager or Construction Manager is a requirement. A valid certificate for at least one of the two roles must be submitted with the tender and the validity must be maintained for the duration of the contract. Require at least 5 years relevant experience.
Construction Manager	Proof of valid SACPCMP registration for either the Project Manager or Construction Manager is a requirement. A valid certificate for at least one of the two roles must be submitted with the tender and the validity must be maintained for the duration of the contract. Require at least 5 years relevant experience.
Health & Safety Officers x 3 (To ensure support 24/7)	SACPCMP – All three resources are registered as a Health and Safety Officers with at least 2 years relevant experience.
Quality Manager	BTech Quality Management with at least 2 years relevant experience.
Schedule Manager/Planner	At least 2 years relevant experience.
Commissioning Manager	A relevant valid technical qualification (mechanical, structural, electrical and/or control & instrumentation) above NQF level 4 with at least 5 years relevant experience.
Administration/Document Controller	At least 2 years relevant experience.

- 7.7.4 Minimum requirements of people employed on the *Site*
- All statutory requirements relating to employees mobilised on site
 - Health and Safety compliance as specified elsewhere
- 7.7.5 The *Contractor* is responsible for managing industrial relations in accordance with their Human Resource Management Plan.

7.8 Training workshops and technology transfer

- 7.8.1 The *Contractor* facilitates the following requirements for training workshops:
- A safety pre-mobilisation workshop
 - Contractor employee safety training programmes

7.9 Contract change management

- 7.9.1 No additional requirements apply to ECC Clause 60 series.

7.10 Provision of bonds and guarantees

- 7.10.1 The form in which a bond or guarantee required by the conditions of contract (if any) is to be provided by the *Contractor* is given in Part 1 Agreements and Contract Data, document C1.3, Sureties.
- 7.10.2 The *Contractor* provides a bond or guarantee as required by the conditions of contract concurrently with the execution by the Parties of the form of agreement for the ECC contract.

7.11 Records of Defined Cost, payments & assessments of compensation events kept by *Contractor*

- 7.11.1 The *Contractor* keeps the following records available for the *Project Manager* to inspect:
- Records of Equipment used and people employed outside the Working Areas (if applicable); and
 - Records of all expenses incurred and equipment, material, parts and resources used as a result of Compensation Events or that leads to Compensation Events.

8 Procurement

8.1 Code of Conduct

Transnet aims to achieve the best value for money when buying or selling goods and obtaining services. This however must be done in an open and fair manner that supports and drives a competitive economy. Underpinning our process are several acts and policies that any supplier dealing with Transnet must understand and support. These are:

- The Transnet Procurement Procedures Manual (PPM);
- Section 217 of the Constitution - the five pillars of Public PSCM (Procurement and Supply Chain Management): fair, equitable, transparent, competitive and cost effective;
- The Public Finance Management Act (PFMA);
- The Broad Based Black Economic Empowerment Act (B-BBEE); and
- The Anti-Corruption Act.

This code of conduct has been included in this contract to formally apprise Transnet Suppliers of Transnet's expectations regarding behaviour and conduct of it's Suppliers.

Prohibition of Bribes, Kickbacks, Unlawful Payments, and Other Corrupt Practices

Transnet is in the process of transforming itself into a self-sustaining State Owned Enterprise, actively competing in the logistics industry. Our aim is to become a world class, profitable, logistics organisation. As such, our transformation is focused on adopting a performance culture and to adopt behaviours that will enable this transformation.

1. *Transnet will not participate in corrupt practices and therefore expects its suppliers to act in a similar manner.*
 - Transnet and its employees will follow the laws of this country and keep accurate business records that reflect actual transactions with and payments to our suppliers.
 - Employees must not accept or request money or anything of value, directly or indirectly, to:
 - Illegally influence their judgement or conduct or to ensure the desired outcome of a sourcing activity;
 - Win or retain business or to influence any act or decision of any decision stakeholders involved in sourcing decisions; or
 - Gain an improper advantage.
 - There may be times when a supplier is confronted with fraudulent or corrupt behaviour of Transnet employees. We expect our Suppliers to use our "Tip-offs Anonymous" Hot line to report these acts. (0800 003 056).
2. *Transnet is firmly committed to the ideas of free and competitive enterprise.*

- Suppliers are expected to comply with all applicable laws and regulations regarding fair competition and antitrust.
 - Transnet does not engage with non-value adding agents or representatives solely for the purpose of increasing B-BBEE spend (fronting)
3. *Transnet's relationship with suppliers requires us to clearly define requirements, exchange information and share mutual benefits.*
- Generally, Suppliers have their own business standards and regulations. Although Transnet cannot control the actions of our suppliers, we will not tolerate any illegal activities. These include, but are not limited to:
 - Misrepresentation of their product (origin of manufacture, specifications, intellectual property rights, etc);
 - Collusion;
 - Failure to disclose accurate information required during the sourcing activity (ownership, financial situation, B-BBEE status, etc.);
 - Corrupt activities listed above; and
 - Harassment, intimidation or other aggressive actions towards Transnet employees.
 - Suppliers must be evaluated and approved before any materials, components, products or services are purchased from them. Rigorous due diligence is conducted and the supplier is expected to participate in an honest and straight forward manner.
 - Suppliers must record and report facts accurately, honestly and objectively. Financial records must be accurate in all material respects.

Conflicts of Interest

1. *A conflict of interest arises when personal interests or activities influence (or appear to influence) the ability to act in the best interests of Transnet.*
- Doing business with family members
 - Having a financial interest in another company in our industry

8.2 The Contractor's Invoices

- 8.2.1 When the *Project Manager* certifies payment (see ECC Clause 51.1) following an assessment date, the *Contractor* complies with the *Employer's* procedure for invoice submission.
- 8.2.2 The invoice must correspond to the *Project Manager's* assessment of the amount due to the *Contractor* as stated in the payment certificate.
- 8.2.3 The invoice states the following:
Invoice addressed to Transnet SOC Ltd;
Transnet SOC Limited's VAT No: 4720103177;
Invoice number;
The *Contractor's* VAT Number; and
The Contract number.
The invoice contains the supporting detail.
- 8.2.4 The invoice is presented either by post or by hand delivery.
- 8.2.5 Invoices submitted by post are addressed to:
Transnet SOC Ltd
Private Bag X4
Gallo Manor
2052
For the attention of The Contract Administrator, Transnet Port Terminals

8.2.6 Invoices submitted by hand are presented to:

Transnet Pot Terminals
Kingsmead Office Park
Stalwart Simelane (Stranger) Street
Durban, South Africa
4001

For the attention of The Contract Administrator, Transnet Port Terminals

8.2.7 The invoice is presented as an original.

8.3 People

8.3.1 Minimum requirements of people employed on the Site

- All statutory requirements relating to employees mobilised on site
- Health and Safety compliance as specified elsewhere

8.3.2 The *Contractor* is responsible for managing industrial relations in accordance with his Human Resource Management Plan.

8.4 Subcontracting

8.4.1 The *Contractor* does not appoint or bring Subcontractors onto Site without the prior acceptance of the *Project Manager* and all Subcontractors are required to conform to the requirements as set out herein, as if they were employees of the *Contractor*.

8.4.2 Where the *Contractor* employs a Subcontractor, who constructs or installs part of the *works* or who supplies Plant and Materials for incorporation into the *works* which involves a Subcontractor operating on the Site and/or Working Areas, then the *Contractor* ensures that any such Subcontractor complies with the various requirements, listed under Section 7. The subcontract documentation places back-to-back obligations on the Subcontractor which reflect the *Contractor's* obligations listed under Section 7.

8.4.3 The *Contractor* ensures that all compliance requirements placed on him by the *Employer* are transferred to the Subcontractor.

8.4.4 The *Contractor* does not deviate from the accepted Subcontractor's list without prior acceptance of the *Project Manager*.

8.4.5 The *Contractor* ensures that the recommended Subcontractor is appointed timeously in accordance with the works programme.

8.4.6 The *Contractor* appoints his Subcontractors under the NEC3 Engineering Contract Subcontract, unless accepted otherwise by the *Project Manager*.

8.4.7 The *Contractor* ensures that the health and safety and environmental requirements placed on him under this contract are transferred to any Subcontracts.

8.4.8 The *Contractor* ensures that the quality assurance requirements placed on him under this contract are transferred to any Subcontracts.

8.4.9 Quality system requirements are to be applied on all Subcontracts to the point where the acceptability of supplies can be demonstrated solely by the conduct of inspection and/or examination of goods upon receipt at the designated point of delivery.

8.4.10 The *Contractor's* Quality Plan to include or reference the Quality Plans of Subcontractors.

8.5 Plant and Materials

8.5.1 The *Contractor* provides Plant and Materials for inclusion in the *works* in accordance with the relevant SABS / SANS / BSI / International codes, unless otherwise stated elsewhere in the *Works Information* provided by the *Employer*. All Plant and Materials are new, unless the use of old or refurbished goods and/or Materials are expressly permitted as stated elsewhere in this *Works Information* or as may be subsequently instructed by the *Project Manager*.

- 8.5.2 Where Plant and Materials for inclusion in the *works* originate from outside the Republic of South Africa, all such Plant and Materials are new and of merchantable quality, to a recognised national standard, with all proprietary products installed to manufacturers' instructions.
- 8.5.3 The *Contractor* replaces any Plant and Materials subject to breakages (whether in the Working Areas or not) or any Plant and Materials not conforming to standards or specifications stated and notifies the *Project Manager* and the *Supervisor* on each occasion where replacement is required.
- 8.5.4 The *Contractor* provides all other Plant and Materials necessary for the *works* not specifically stated to be provided "free issue" by the *Employer*.
- 8.5.5 *Contractor's* procurement of Plant and Materials. The delivery of the Plant and Materials shall be made to the nominated delivery address, and the *Project Manager* shall be notified that the Plant and materials have been delivered and are available to be inspected by the *Supervisor*. All equipment procured as part of this Contract shall be guaranteed against latent defects and faulty workmanship for a period of at least **12 months from date of commissioning, or 18 months from date of delivery**, whichever expires first. All information relating to plant and materials procured shall be obtained from the vendor, and collated, where relevant, in the Operating and maintenance Manuals.
- 8.5.6 First fills are included in the scope of this Contract on all new and refurbished components, and the *Contractor* shall provide all lubricant, hydraulic fluids, and other fills required for the efficient operation of each equipment item as part of this Contract.
- 8.5.7 At the request of the *Project Manager* and before commencing with the commissioning on the plant and Materials, the *Contractor* provides a list of all critical / strategic spares to be kept by the *Employer* for the Plant and Materials, and the *Employer* shall select the specific items for purchasing as part of this Contract at the discretion of the *Project Manager*, at the prices quoted (i.e. prices indicated in this contract document) by the *Contractor*.

8.6 Tests and inspections before delivery

- 8.6.1 The *Contractor* submits to the Supervisor details to certify that tests and inspections have been carried out on Plant and Materials by others which include all new components, assemblies and sub-assemblies included in this Contract, as per the Commissioning Plan, Annexure 26.
- 8.6.2 The *Contractor* shall identify to the Supervisor all equipment items, sub-assemblies, and fully assembled sections of equipment to be tested, before it is released for shipment to site and installation. The shop testing shall be witnessed by the Supervisor or his nominee prior to releasing it for shipment, and a release certificate shall be issued by the Supervisor once the equipment has been tested successfully.

8.7 Marking Plant and Materials outside the Working Areas

- 8.7.1 The *Contractor* prepares and marks items of Plant and Materials outside the Working Areas, that has been paid for by the *Employer*, either with a metal plate, fixed to each loose equipment item, assembly, or sub-assembly, with the following words written in permanent ink on the tag, or by permanent marker written on the material as follows;
- Item: (description of item)
 - Property of Transnet Ltd
 - Project description and No.
- 8.7.2 The Contractor is to take digital photographs for issuing to the Supervisor as proof of marking.

8.8 Contractor's Equipment (including temporary works).

- 8.8.1 The *Contractor* provides the *Project Manager* with details of any specialised *Contractor's* Equipment to be procured as part of this *Contract* for the execution of the works. The *Contractor* will provide any specialised equipment required for routine maintenance of the works as part of this contract.

8.9 Preparation of post Completion contracts

8.9.1 Prior to Contract Completion, the *Contractor* provides to the *Employer* costs for providing the following assistance to the Employer post Completion:

Full maintenance of the Plant and Materials that is fabricated and erected as part of this Contract. The maintenance shall include, inter alia, the following;

- Regular weekly and monthly inspections of the machine
- Regular maintenance activities as required, at the specified intervals, on the machine
- Attendance to call-outs and emergency repairs required to maintain the operability of the machine, 24 hours per day/ 7 days a week.



TRANSNET PORT TERMINALS

TENDER NUMBER: TPT/2024/03/0066/60631/RFP

DESCRIPTION OF THE SERVICES: FOR THE SUPPLY OF SERVICES TO REFURBISH STACKER RECLAIMER 3 AT THE SALDANHA IRON ORE TERMINAL FOR TRANSNET SOC LTD (REG.NO.1990/000900/30) OPERATING AS TRANSNET PORT TERMINALS, (HEREINAFTER REFERRED TO AS "TPT"), AS A ONCE OFF SUPPLY.

C1.1: Form of Offer & Acceptance

Offer

The Employer, identified in the Acceptance signature block, has solicited offers to enter into a contract for the procurement of:

FOR THE SUPPLY OF SERVICES TO REFURBISH STACKER RECLAIMER 3 AT THE SALDANHA IRON ORE TERMINAL FOR TRANSNET SOC LTD (REG.NO.1990/000900/30) OPERATING AS TRANSNET PORT TERMINALS, (HEREINAFTER REFERRED TO AS "TPT"), AS A ONCE OFF SUPPLY.

By the representative of the tenderer, deemed to be duly authorised, signing this part of this Form of Offer and Acceptance the tenderer offers to perform all of the obligations and liabilities of the *Contractor* under the contract including compliance with all its terms and conditions according to their true intent and meaning for an amount to be determined in accordance with the *conditions of contract* identified in the Contract Data.

The offered total of the Prices exclusive of VAT is	R
Value Added Tax @ 15% is	R
The offered total of the Prices inclusive of VAT is	R
(in words)	

This Offer may be accepted by the Employer by signing the Acceptance part of this Form of Offer and Acceptance and returning one copy of this document including the Schedule of Deviations (if any) to the tenderer before the end of the period of validity stated in the Tender Data, or other period as agreed, whereupon the tenderer becomes the party named as the *Contractor* in the *conditions of contract* identified in the Contract Data.

Signature(s)

Name(s)

Capacity

For the tenderer:

(Insert name and address of organisation)

Name & signature of witness

Date

Tenderer's CIDB registration number:

TRANSNET PORT TERMINALS

TENDER NUMBER: TPT/2024/03/0066/60631/RFP

DESCRIPTION OF THE SERVICES: FOR THE SUPPLY OF SERVICES TO REFURBISH STACKER RECLAIMER 3 AT THE SALDANHA IRON ORE TERMINAL FOR TRANSNET SOC LTD (REG.NO.1990/000900/30) OPERATING AS TRANSNET PORT TERMINALS, (HEREINAFTER REFERRED TO AS "TPT"), AS A ONCE OFF SUPPLY.

Acceptance

By signing this part of this Form of Offer and Acceptance, the *Employer* identified below accepts the tenderer's Offer. In consideration thereof, the *Employer* shall pay the *Contractor* the amount due in accordance with the *conditions of contract* identified in the Contract Data. Acceptance of the tenderer's Offer shall form an agreement between the *Employer* and the tenderer upon the terms and conditions contained in this agreement and in the contract that is the subject of this agreement.

The terms of the contract, are contained in:

Part C1	Agreements and Contract Data, (which includes this Form of Offer and Acceptance)
Part C2	Pricing Data
Part C3	Scope of Work: Works Information
Part C4	Site Information

and drawings and documents (or parts thereof), which may be incorporated by reference into the above listed Parts.

Deviations from and amendments to the documents listed in the Tender Data and any addenda thereto listed in the Returnable Schedules as well as any changes to the terms of the Offer agreed by the tenderer and the Employer during this process of offer and acceptance, are contained in the Schedule of Deviations attached to and forming part of this Form of Offer and Acceptance. No amendments to or deviations from said documents are valid unless contained in this Schedule.

The tenderer shall within two weeks of receiving a completed copy of this agreement, including the Schedule of Deviations (if any), contact the Employer's agent (whose details are given in the Contract Data) to arrange the delivery of any securities, bonds, guarantees, proof of insurance and any other documentation to be provided in terms of the *conditions of contract* identified in the Contract Data at, or just after, the date this agreement comes into effect. Failure to fulfil any of these obligations in accordance with those terms shall constitute a repudiation of this agreement.

Notwithstanding anything contained herein, this agreement comes into effect on the date when the tenderer receives one fully completed original copy of this document, including the Schedule of Deviations (if any).



TRANSNET PORT TERMINALS

TENDER NUMBER: TPT/2024/03/0066/60631/RFP

DESCRIPTION OF THE SERVICES: FOR THE SUPPLY OF SERVICES TO REFURBISH STACKER RECLAIMER 3 AT THE SALDANHA IRON ORE TERMINAL FOR TRANSNET SOC LTD (REG.NO.1990/000900/30) OPERATING AS TRANSNET PORT TERMINALS, (HEREINAFTER REFERRED TO AS "TPT"), AS A ONCE OFF SUPPLY.

Unless the tenderer (now Contractor) within five working days of the date of such receipt notifies the Employer in writing of any reason why he cannot accept the contents of this agreement, this agreement shall constitute a binding contract between the Parties.

Signature(s)

Name(s)

Capacity

for the Employer

Transnet SOC Ltd

(Insert name and address of organisation)

Name & signature of witness

Date

TRANSNET PORT TERMINALS

TENDER NUMBER: TPT/2024/03/0066/60631/RFP

DESCRIPTION OF THE SERVICES: FOR THE SUPPLY OF SERVICES TO REFURBISH STACKER RECLAIMER 3 AT THE SALDANHA IRON ORE TERMINAL FOR TRANSNET SOC LTD (REG.NO.1990/000900/30) OPERATING AS TRANSNET PORT TERMINALS, (HEREINAFTER REFERRED TO AS "TPT"), AS A ONCE OFF SUPPLY.

Schedule of Deviations

Note:

1. To be completed by the Employer prior to award of contract. This part of the Offer & Acceptance would not be required if the contract has been developed by negotiation between the Parties and is not the result of a process of competitive tendering.
2. The extent of deviations from the tender documents issued by the Employer prior to the tender closing date is limited to those permitted in terms of the Conditions of Tender.
3. A tenderer's covering letter must not be included in the final contract document. Should any matter in such letter, which constitutes a deviation as aforesaid be the subject of agreement reached during the process of Offer and Acceptance, the outcome of such agreement shall be recorded here and the final draft of the contract documents shall be revised to incorporate the effect of it.

No.	Subject	Details
1		
2		
3		
4		

By the duly authorised representatives signing this Schedule of Deviations below, the Employer and the tenderer agree to and accept this Schedule of Deviations as the only deviations from and amendments to the documents listed in the Tender Data and any addenda thereto listed in the Tender Schedules, as well as any confirmation, clarification or changes to the terms of the Offer agreed by the tenderer and the Employer during this process of Offer and Acceptance.

It is expressly agreed that no other matter whether in writing, oral communication or implied during the period between the issue of the tender documents and the receipt by the tenderer of a completed signed copy of this Form shall have any meaning or effect in the contract between the parties arising from this Agreement.

	For the tenderer:	For the Employer
Signature
Name
Capacity
On behalf of	<i>(Insert name and address of organisation)</i>	Transnet SOC Ltd
Name & signature of witness
Date



TRANSNET PORT TERMINALS

TENDER NUMBER: TPT/2024/03/0066/60631/RFP

DESCRIPTION OF THE SERVICES: FOR THE SUPPLY OF SERVICES TO REFURBISH STACKER RECLAIMER 3 AT THE SALDANHA IRON ORE TERMINAL FOR TRANSNET SOC LTD (REG.NO.1990/000900/30) OPERATING AS TRANSNET PORT TERMINALS, (HEREINAFTER REFERRED TO AS "TPT"), AS A ONCE OFF SUPPLY.



TRANSNET PORT TERMINALS
CONTRACT NUMBER: TPT/2024/03/0066/60631/RFP
DESCRIPTION OF THE GOODS: SUPPLY OF SERVICES TO REFURBISH STACKER RECLAIMER 3 AT THE SALDANHA IRON ORE TERMINAL FOR TRANSNET SOC LTD (REG.NO.1990/000900/30) OPERATING AS TRANSNET PORT TERMINALS, (HEREINAFTER REFERRED TO AS "TPT"), AS A ONCE OFF SUPPLY

C1.3 Forms of Securities

Pro forma Performance Guarantee

For use with the NEC3 Engineering & Construction Contract - June 2005 (with amendments June 2006 and April 2013)

The *conditions of contract* stated in the Contract Data Part 1 include the following Secondary Option:

Option X13: Performance bond

The pro forma document for this Guarantee is provided here for convenience but is to be treated as part of the *Works Information*.

The organisation providing the Guarantee does so by copying the pro forma document onto its letterhead without any change to the text or format and completing the required details. The completed document is then given to the *Employer* within the time stated in the contract.

The Performance Bond needs to be issued by an institution that are reasonably acceptable to the *Employer*.

Transnet may choose to not to accept an Issuer. Should the issuer not being accepted, the performance bond needs to be replaced by an issuer that are acceptable to Transnet. Issuers need to be verified for acceptance by Transnet before a performance bond is issued.



TRANSNET PORT TERMINALS
 CONTRACT NUMBER: TPT/2024/03/0066/60631/RFP
 DESCRIPTION OF THE GOODS: SUPPLY OF SERVICES TO REFURBISH STACKER RECLAIMER 3 AT THE SALDANHA IRON ORE TERMINAL FOR TRANSNET SOC LTD (REG.NO.1990/000900/30) OPERATING AS TRANSNET PORT TERMINALS, (HEREINAFTER REFERRED TO AS "TPT"), AS A ONCE OFF SUPPLY

Pro-forma Performance Bond (for use with Option X13)

(to be reproduced exactly as shown below on the letterhead of the Surety)

Transnet SOC Ltd
 C/o Transnet
 Transnet Corporate Centre
 Waterfall Business Estate
 9 Country Estate Drive
 Midrand

Date:

Dear Sirs,

Performance Bond for Contract No.

With reference to the above numbered contract made or to be made between

Transnet SOC Limited, Registration No. 1990/000900/30 (the *Employer*) and

{Insert registered name and address of the Contractor} (the *Contractor*), for

{Insert details of the works from the Contract Data} (the *works*).

I/We the undersigned _____
 on behalf of the
 Guarantor _____
 of physical address _____

and duly authorised thereto do hereby bind ourselves as Guarantor and co-principal debtors in solidum for the due and faithful performance of all the terms and conditions of the Contract by the *Contractor* and for all losses, damages and expenses that may be suffered or incurred by the *Employer* as a result of non-performance of the Contract by the *Contractor*, subject to the following conditions:

1. The terms *Employer*, *Contractor*, *Project Manager*, *works* and Completion Certificate have the meaning as assigned to them by the *conditions of contract* stated in the Contract Data for the aforesaid Contract.
2. We renounce all benefits from the legal exceptions "Benefit of Excussion and Division", "No value received" and all other exceptions which might or could be pleaded against the validity of this bond, with the meaning and effect of which exceptions we declare ourselves to be fully acquainted.
3. The *Employer* has the absolute right to arrange his affairs with the *Contractor* in any manner which the *Employer* deems fit and without being advised thereof the Guarantor shall not have the right to claim his release on account of any conduct alleged to be prejudicial to the Guarantor. Without derogating from the foregoing compromise, extension of the construction period, indulgence, release or variation of the *Contractor's* obligation shall not affect the validity of this performance bond.



TRANSNET PORT TERMINALS

CONTRACT NUMBER: TPT/2024/03/0066/60631/RFP

DESCRIPTION OF THE GOODS: SUPPLY OF SERVICES TO REFURBISH STACKER RECLAIMER 3 AT THE SALDANHA IRON ORE TERMINAL FOR TRANSNET SOC LTD (REG.NO.1990/000900/30) OPERATING AS TRANSNET PORT TERMINALS, (HEREINAFTER REFERRED TO AS "TPT"), AS A ONCE OFF SUPPLY

4. This bond will lapse on the earlier of
 - the date that the Guarantor receives a notice from the *Project Manager* stating that the Completion Certificate for the whole of the *works* has been issued, that all amounts due from the *Contractor* as certified in terms of the contract have been received by the *Employer* and that the *Contractor* has fulfilled all his obligations under the Contract, or
 - the date that the Surety issues a replacement Performance Bond for such lesser or higher amount as may be required by the *Project Manager*.
5. Always provided that this bond will not lapse in the event the Guarantor is notified by the *Project Manager*, (before the dates above), of the *Employer's* intention to institute claims and the particulars thereof, in which event this bond shall remain in force until all such claims are paid and settled.
6. The amount of the bond shall be payable to the *Employer* upon the *Employer's* demand and no later than 7 days following the submission to the Guarantor of a certificate signed by the *Project Manager* stating the amount of the *Employer's* losses, damages and expenses incurred as a result of the non-performance aforesaid. The signed certificate shall be deemed to be conclusive proof of the extent of the *Employer's* loss, damage and expense.
7. Our total liability hereunder shall not exceed the sum of:
 (say) _____
 R _____
8. This Performance Bond is neither negotiable nor transferable and is governed by the laws of the Republic of South Africa, subject to the jurisdiction of the courts of the Republic of South Africa

Signed at _____ on this _____ day of _____ 201_

Signature(s)	_____
Name(s) (printed)	_____
Position in Guarantor company	_____
Signature of Witness(s)	_____
Name(s) (printed)	_____



TRANSNET PORT TERMINALS

TENDER NUMBER: TPT/2024/03/0066/60631/RFP

DESCRIPTION OF THE SERVICES: FOR THE SUPPLY OF SERVICES TO REFURBISH STACKER RECLAIMER 3 AT THE SALDANHA IRON ORE TERMINAL FOR TRANSNET SOC LTD (REG.NO.1990/000900/30) OPERATING AS TRANSNET PORT TERMINALS, (HEREINAFTER REFERRED TO AS "TPT"), AS A ONCE OFF SUPPLY.

PART 2: PRICING DATA

Document reference	Title	No of pages
C2.1	Pricing instructions: Option A	2
C2.2	Activity Schedule	3

C2.1 Pricing Instructions: Option A

1. The *conditions of contract*

1.1. How the contract prices work and assesses it for progress payments

Clause 11 in NEC3 Engineering and Construction Contract, June 2005, (with amendments June 2006 and April 2013) (ECC) Option A states:

Identified and defined terms 11
11.2

(20) The Activity Schedule is the *activity schedule* unless later changed in accordance with this contract.

(22) Defined Cost is the cost of the components in the Shorter Schedule of Cost Components whether work is subcontracted or not excluding the cost of preparing quotations for compensation events.

(27) The Price for Work Done to Date is the total of the Prices for

- each group of completed activities and
- each completed activity which is not in a group

A completed activity is one which is without Defects which would either delay or be covered by immediately following work.

(30) The Prices are the lump sums for each of the activities on the Activity Schedule unless later changed in accordance with this contract.

1.2. Measurement and Payment

1.2.1 The Activity Schedule provides the basis of all valuations of the Price for Work Done to Date, payments in multiple currencies, price adjustments for inflation and general progress monitoring.

1.2.2 The amount due at each assessment date is based on **completed activities and/or milestones** as indicated on the Activity Schedule.

1.2.3 The Activity Schedule work breakdown structure provided by the *Contractor* is based on the Activity Schedule provided by the *Employer*. The activities listed by the *Employer* are the minimum activities acceptable and identify the specific activities which are required to achieve Completion. The activity schedule work breakdown structure is compiled to the satisfaction of the *Project Manager* with any additions and/or amendments deemed necessary.

TRANSNET PORT TERMINALS

TENDER NUMBER: TPT/2024/03/0066/60631/RFP

DESCRIPTION OF THE SERVICES: FOR THE SUPPLY OF SERVICES TO REFURBISH STACKER RECLAIMER 3 AT THE SALDANHA IRON ORE TERMINAL FOR TRANSNET SOC LTD (REG.NO.1990/000900/30) OPERATING AS TRANSNET PORT TERMINALS, (HEREINAFTER REFERRED TO AS "TPT"), AS A ONCE OFF SUPPLY.

- 1.2.4 The *Contractor's* detailed Activity Schedule summates back to the Activity Schedule provided by the *Employer* and is in sufficient detail to monitor completion of activities related to the Accepted Programme in order that payment of completed activities may be assessed.
- 1.2.5 The short descriptions in the Activity Schedule are for identification purposes only. All work described in the Works Information is deemed included in the activities.
- 1.2.6 The Activity Schedule is integrated with the Prices, Accepted Programme and where required the forecast rate of payment schedule.
- 1.2.7 Activities in multiple currencies are separately identified on both the Activity Schedule and the Accepted Programme for each currency.
- 1.2.8 The tendered total of the prices as stated in the Contract Data is obtained from the Activity Schedule summary. The tendered total of the prices includes for all direct and indirect costs, overheads, profits, risks, liabilities and obligations relative to the Contract.

TRANSNET PORT TERMINALS

TENDER NUMBER: TPT/2024/03/0066/60631/RFP

DESCRIPTION OF THE SERVICES: FOR THE SUPPLY OF SERVICES TO REFURBISH STACKER RECLAIMER 3 AT THE SALDANHA IRON ORE TERMINAL FOR TRANSNET SOC LTD (REG.NO.1990/000900/30) OPERATING AS TRANSNET PORT TERMINALS, (HEREINAFTER REFERRED TO AS "TPT"), AS A ONCE OFF SUPPLY.

C2.2 Activity Schedule

The price reflected below must be **fixed and firm**. Failure to provide a fixed and firm price will declare the tender non-responsive.

The price must be based on DDP (Saldanha) and must be in Rands.

The price tendered must be for the full scope and include all requirements

The Tenderer details his Activity Schedule below or refers to his Activity Schedule and attaches it to this schedule.

The details given below serve as guidelines only and the Tenderer may split or combine the activities to suit his methods.

EQUIPMENT REFIT PROJECT (PHASE 4)			
STACKER RECLAIMER 3			(Excl. VAT)
Activity No	Activity Description	Sum	Price of each Activity
1	<p>For the 2024 Shut: Preliminary and General, project management and overhead costs, all labour, craneage, equipment, vehicles, tools, access requirements, assessing free issue equipment, civils works for site establishment and execution of works, also including meeting the requirements of Health and Safety, Environmental, Quality, Construction Management, Execution and Commissioning, as stipulated in the Scope of Work. To cater for site establishment and de-establishment for the 2024 Shut.</p> <p>Contractor to provide a detailed cost breakdown for this item.</p>	Sum	
2	<p>For the 2025 shut: Preliminary and General, project management and overhead costs, all labour, craneage, equipment, vehicles, tools, access requirements, assessing free issue equipment, civils works for site establishment and execution of works, also including meeting the requirements of Health and Safety, Environmental, Quality, Construction Management, Execution and Commissioning, as stipulated in the Scope of Work. To cater for site establishment and de-establishment for the 2025 Shut.</p> <p>Contractor to provide a detailed cost breakdown for this item.</p>	Sum	
3	Training	Sum	
4	SR3 & TC3 high pressure Cleaning	Sum	

TRANSNET PORT TERMINALS

TENDER NUMBER: TPT/2024/03/0066/60631/RFP

DESCRIPTION OF THE SERVICES: FOR THE SUPPLY OF SERVICES TO REFURBISH STACKER RECLAIMER 3 AT THE SALDANHA IRON ORE TERMINAL FOR TRANSNET SOC LTD (REG.NO.1990/000900/30) OPERATING AS TRANSNET PORT TERMINALS, (HEREINAFTER REFERRED TO AS "TPT"), AS A ONCE OFF SUPPLY.

EQUIPMENT REFIT PROJECT (PHASE 4)			
STACKER RECLAIMER 3			(Excl. VAT)
Activity No	Activity Description	Sum	Price of each Activity
5	Drive/Idle wheel bogie assemblies	Sum	
6	Single Idle Wheel assemblies for Tripper Car	Sum	
7	Double Idle Wheel assemblies for Tripper Car	Sum	
8	Wheel assemblies for SR	Sum	
9	Centralised Automatic Lube System	Sum	
10	Travel Brakes	Sum	
11	Slew Drive Assembly	Sum	
12	Set of Weather Protection Enclosures	Sum	
13	Hose Reel	Sum	
14	Operator Cab (Stainless steel Cab)	Sum	
15	Operators Chair	Sum	
16	S/R T Bar Festoon	Sum	
17	Slew Cable Carrier	Sum	
18	Main Power Cable Reel	Sum	
19	Slew Drive VFD's	Sum	
20	Travel Drive VFDs	Sum	
21	Bucket wheel VFD	Sum	
22	VFD spares	Sum	
23	Main PLC	Sum	
24	Corrosion Protection (SR and Tripper car)	Sum	
25	Shipping Containers	Sum	
26	Structural/weld repairs/NDT's of critical areas/Bolt replacement	Sum	

TRANSNET PORT TERMINALS

TENDER NUMBER: TPT/2024/03/0066/60631/RFP

DESCRIPTION OF THE SERVICES: FOR THE SUPPLY OF SERVICES TO REFURBISH STACKER RECLAIMER 3 AT THE SALDANHA IRON ORE TERMINAL FOR TRANSNET SOC LTD (REG.NO.1990/000900/30) OPERATING AS TRANSNET PORT TERMINALS, (HEREINAFTER REFERRED TO AS "TPT"), AS A ONCE OFF SUPPLY.

EQUIPMENT REFIT PROJECT (PHASE 4)			
STACKER RECLAIMER 3			(Excl. VAT)
Activity No	Activity Description	Sum	Price of each Activity
27	Boom Conveyor Drive Train set (supply and install)	Sum	
28	Boom Conveyor Drive Train sets (supply as spares)	Sum	
29	Incline Conveyor Drive Train set (supply and install)	Sum	
30	Incline Conveyor Drive Train sets (supply as spares)	Sum	
31	Boom and Incline Conveyor Drive Pulleys set (supply and install)	Sum	
32	Boom and Incline Conveyors Drive Pulleys sets (supply as spares)	Sum	
33	Simocode Modules in the Gantry MCC	Sum	
34	Replace Air conditioning within Gantry E-House, Extend/Seal Roof and relocate Condenser	Sum	
35	Operators Fire Escape	Sum	
36	Refurbish Dust Suppression System	Sum	
37	Replacement of Local Maintenance Stations / Calipers / Chains	Sum	
38	HT Switchgear power relays (set)	Sum	

Total Price (Excl. VAT) to be carried over to the Form of Offer & Acceptance C1.1 _____

C1.2 ECC Contract Data

Part one - Data provided by the *Employer*

Clause	Statement	Data
1	<p>General</p> <p>The <i>conditions of contract</i> are the core clauses and the clauses for main Option</p>	<p>A: Priced contract with activity schedule</p> <hr/> <p>W1: Dispute resolution procedure</p> <hr/> <p>dispute resolution Option and secondary Options</p>
		<p>X1: Price adjustment for inflation</p> <p>X2: Changes in the law</p> <p>X4: Parent company guarantee</p> <p>X5: Sectional Completion</p> <p>X7: Delay damages</p> <p>X13: Performance Bond</p> <p>X18: Limitation of liability</p> <p>X20: Key performance indicators</p> <p>Z: <i>Additional conditions of contract</i></p>
	<p>of the NEC3 Engineering and Construction Contract June 2005 (amended June 2006 and April 2013)</p>	

TRANSNET PORT TERMINALS

TENDER NUMBER: TPT/2024/03/0066/60631/RFP

DESCRIPTION OF THE GOODS: SUPPLY OF SERVICES TO REFURBISH STACKER RECLAIMER 3 AT THE SALDANHA IRON ORE TERMINAL FOR TRANSNET SOC LTD (REG.NO.1990/000900/30) OPERATING AS TRANSNET PORT TERMINALS, (HEREINAFTER REFERRED TO AS "TPT"), AS A ONCE OFF SUPPLY.

10.1	The <i>Employer</i> is:	Transnet SOC Ltd (Registration No. 1990/000900/30)
	Address	Registered address: 138 Eloff Street Braamfontein Johannesburg 2000
	Having elected its Contractual Address for the purposes of this contract as:	Transnet Port Terminals Kingsmead Office Park Stalwart Simelane (Stanger) Street Durban 4001
10.1	The <i>Project Manager</i> is: (Name)	Francois Horton
	Address	Transnet Port Terminals Bulk Terminal Saldanha Saldanha, South Africa 7395
	Tel	022 703 4816
	e-mail	francois.horton@transnet.net
10.1	The <i>Supervisor</i> is: (Name)	Jobe Zulu
	Address	Transnet Port Terminals Administration Building 1 Container Rd, Foreshore Cape Town, South Africa 7441
	Tel No.	031 361 2066
	e-mail	Jobe.Zulu@transnet.net
11.2(13)	The <i>works</i> are	Supply of services to refurbish stacker reclaimer 3 at the Saldanha iron ore terminal for Transnet soc ltd (reg.no.1990/000900/30) operating as Transnet Port Terminals, (hereinafter referred to as "TPT"), as a once off supply.
11.2(14)	The following matters will be included in the Risk Register	

TRANSNET PORT TERMINALS

TENDER NUMBER: TPT/2024/03/0066/60631/RFP

DESCRIPTION OF THE GOODS: SUPPLY OF SERVICES TO REFURBISH STACKER RECLAIMER 3 AT THE SALDANHA IRON ORE TERMINAL FOR TRANSNET SOC LTD (REG.NO.1990/000900/30) OPERATING AS TRANSNET PORT TERMINALS, (HEREINAFTER REFERRED TO AS "TPT"), AS A ONCE OFF SUPPLY.

11.2(15)	The <i>boundaries of the site</i> are	As stated in Part C4.1. Saldanha Iron Ore Terminal	
11.2(16)	The Site Information is in	Part C4	
11.2(19)	The Works Information is in	Part C3: Scope of Works	
12.2	The <i>law of the contract</i> is the law of	the Republic of South Africa subject to the jurisdiction of the Courts of South Africa.	
13.1	The <i>language of this contract</i> is	English	
13.3	The <i>period for reply</i> is	2 weeks	
2	The Contractor's main responsibilities	No additional data is required for this section of the <i>conditions of contract</i>.	
3	Time		
11.2(3)	The <i>completion date</i> for the whole of the <i>works</i> is	BTA	
11.2(9)	The <i>key dates</i> and the <i>conditions</i> to be met are:	Condition to be met	key date
		1 Site establishment completed for 2024 shut	31 August 2024
		2 Start with 2024 shut refurbishment works	1 September 2024
		3 Complete 2024 refurbishment works	1 October 2024
		4 Site establishment completed for 2025 shut	31 August 2025
		5 Start with 2025 shut refurbishment works	1 September 2025
		6 Complete 2025 refurbishment works	1 October 2025
30.1	The <i>access dates</i> are	Part of the Site	Date

	1 OEM & ECM Offices & Storage area as indicated on Figure 1 of the SOW.	15 August 2024 for 2024 Shut and 15 August 2025 for 2025 Shut
	2 OEM working area as indicated on Figure 1 of the SOW.	7am, 1 September 2024 for 2024 Shut and 7am, 1 September 2025 for 2025 Shut
31.1	The <i>Contractor</i> is to submit a first programme for acceptance within	Two (2) weeks of the Contract Date.
31.2	The <i>starting date</i> is	15 August 2024
32.2	The <i>Contractor</i> submits revised programmes at intervals no longer than	Two (2) weeks.
35.1	The <i>Employer</i> is not willing to take over the <i>works</i> before the Completion Date.	
4	Testing and Defects	
42.2	The <i>defects date</i> is	52 (fifty-two) weeks after Completion of the whole of the <i>works</i>.
43.2	except that the <i>defect correction period</i> for	a defect which constrains the machines safe operating or operating capacity to 50% or less is 5 days
5	Payment	
50.1	The <i>assessment interval</i> is	25th (twenty fifth) day of each successive month.
51.1	The <i>currency of this contract</i> is the	South African Rand.

51.2	The period within which payments are made is	Payment will be effected on or before the last day of the month following the month during which a valid Tax Invoice and Statement were received.
51.4	The <i>interest rate</i> is	the prime lending rate of Standard Bank of South Africa.

6	Compensation events	
60.1(13)	The <i>weather measurements</i> to be recorded for each calendar month are,	<p>the cumulative rainfall (mm)</p> <p>the number of days with rainfall more than 10 mm</p> <p>the number of days with minimum air temperature less than 0 degrees Celsius</p> <p>the number of days with snow lying at 08:00 hours South African Time</p> <p>and these measurements:</p>
	The place where weather is to be recorded (on the Site) is:	On Site at Saldanha Iron Ore Terminal
	The <i>weather data</i> are the records of past <i>weather measurements</i> for each calendar month which were recorded at:	Saldanha Station
	and which are available from:	South African Weather Service 012 367 6023 or info3@weathersa.co.za.

7	Title	No additional data is required for this section of the <i>conditions of contract</i>.
----------	--------------	--

8	Risks and insurance	
80.1	These are additional <i>Employer's</i> risks	<p>a) The start date and period of each Shut must still be approved between Transnet and the industry. The dates provided herein are therefore subject to change.</p> <p>b) Industrial action which may cause work stoppage and delays.</p>

84.1	The <i>Employer</i> provides these insurances from the Insurance Table	
	1 Insurance against:	Loss of or damage to the <i>works</i>, Plant and Materials is as stated in the Insurance policy for Contract Works/ Public Liability.
	Cover / indemnity:	to the extent as stated in the insurance policy for Contract Works / Public Liability
	The deductibles are:	as stated in the insurance policy for Contract Works / Public Liability
	2 Insurance against:	Loss of or damage to property (except the <i>works</i>, Plant and Materials & Equipment) and liability for bodily injury to or death of a person (not an employee of the <i>Contractor</i>) arising out of or in connection with the performance of the Contract as stated in the insurance policy for Contract Works / Public Liability
	Cover / indemnity	Is to the extent as stated in the insurance policy for Contract Works / Public Liability
	The deductibles are	as stated in the insurance policy for Contract Works / Public Liability
	3 Insurance against:	Loss of or damage to Equipment (Temporary Works only) as stated in the insurance policy for contract Works and Public Liability
	Cover / indemnity	Is to the extent as stated in the insurance policy for Contract Works / Public Liability
	The deductibles are:	As stated in the insurance policy for Contract Works / Public Liability
	4 Insurance against:	Contract Works SASRIA insurance subject to the terms, exceptions and conditions of the SASRIA coupon
	Cover / indemnity	Cover / indemnity is to the extent provided by the SASRIA coupon

<p>The deductibles are</p>	<p>The deductibles are, in respect of each and every theft claim, 0,1% of the contract value subject to a minimum of R2,500 and a maximum of R25,000.</p>
<p>Note:</p>	<p>The deductibles for the insurance as stated above are listed in the document titled "Certificate of Insurance: Transnet (SOC) Limited Principal Controlled Insurance."</p>
<p>84.1 The minimum limit of indemnity for insurance in respect of death of or bodily injury to employees of the <i>Contractor</i> arising out of and in the course of their employment in connection with this contract for any one event is</p> <p>The <i>Contractor</i> provides these additional Insurances</p>	<p>The <i>Contractor</i> must comply at a minimum with the provisions of the Compensation for Occupational Injuries and Diseases Act No. 130 of 1993 as amended.</p> <ol style="list-style-type: none"> 1 Where the contract requires that the design of any part of the <i>works</i> shall be provided by the <i>Contractor</i> the <i>Contractor</i> shall satisfy the <i>Employer</i> that professional indemnity insurance cover in connection therewith has been affected 2 Where the contract involves manufacture, and/or fabrication of Plant & Materials, components or other goods to be incorporated into the <i>works</i> at premises other than the site, the <i>Contractor</i> shall satisfy the <i>Employer</i> that such plant & materials, components or other goods for incorporation in the <i>works</i> are adequately insured during manufacture and/or fabrication and transportation to the site. 3 Should the <i>Employer</i> have an insurable interest in such items during manufacture, and/or fabrication, such interest shall be noted by endorsement to the <i>Contractor's</i> policies of insurance as well as those of any sub-contractor

- 4 Motor Vehicle Liability Insurance comprising (as a minimum) "Balance of Third Party" Risks including Passenger and Unauthorised Passenger Liability indemnity with a minimum indemnity limit of R 5 000 000.**
- 5 Marine Craft Hull insurance in respect of all marine craft or vessels utilised in performance of the Works for a sum sufficient to provide for their replacement**
- 6 Protection and Indemnity Insurance in respect of all marine craft or vessels utilised in performance of the Works extended for Specialist Operations with a minimum indemnity limit of R 20,000,000**
- 7 The insurance coverage referred to in 1, 2, 3, 4, 5 and 6 above shall be obtained from an insurer(s) in terms of an insurance policy approved by the *Employer*. The *Contractor* shall arrange with the insurer to submit to the *Project Manager* the original and the duplicate original of the policy or policies of insurance and the receipts for payment of current premiums, together with a certificate from the insurer or insurance broker concerned, confirming that the policy or policies provide the full coverage as required. The original policy will be returned to the *Contractor*.**

84.2 The minimum limit of indemnity for insurance in respect of loss of or damage to property (except the works, Plant, Materials and Equipment) and liability for bodily injury to or death of a person (not an employee of the *Contractor*) caused by activity in connection with this contract for any one event is

Whatever the *Contractor* requires in addition to the amount of insurance taken out by the *Employer* for the same risk.

84.2	The insurance against loss of or damage to the works, Plant and Materials as stated in the insurance policy for contract works and public liability selected from:	Principal Controlled Insurance policy for Contract OR Project Specific Insurance for the contract
9	Termination	There is no additional Contract Data required for this section of the <i>conditions of contract</i>.
10	Data for main Option clause	
A	Priced contract with Activity Schedule	No additional data is required for this Option.
60.6	The <i>method of measurement</i> is	The Activity Schedule work breakdown structure provided by the <i>Contractor</i> is based on the Activity Schedule provided by the <i>Employer</i>. The activities listed by the <i>Employer</i> are the minimum activities acceptable and identify the specific activities which are required to achieve Completion. The activity schedule work breakdown structure is compiled to the satisfaction of the <i>Project Manager</i> with any additions and/or amendments deemed necessary.
11	Data for Option W1	
W1.1	The <i>Adjudicator</i> is	Both parties will agree as and when a dispute arises. If the parties cannot reach an agreement on the <i>Adjudicator</i>, the Chairman of the Association of Arbitrators will appoint an <i>Adjudicator</i>.
W1.2(3)	The <i>Adjudicator nominating body</i> is: If no <i>Adjudicator nominating body</i> is entered, it is:	The Chairman of the Association of Arbitrators (Southern Africa) the Association of Arbitrators (Southern Africa)
W1.4(2)	The <i>tribunal</i> is:	Arbitration

W1.4(5)	The <i>arbitration procedure</i> is	The Rules for the Conduct of Arbitrations of the Association of Arbitrators (Southern Africa)
	The place where arbitration is to be held is	Sadhana, South Africa
	The person or organisation who will choose an arbitrator - if the Parties cannot agree a choice or - if the arbitration procedure does not state who selects an arbitrator, is	The Chairman of the Association of Arbitrators (Southern Africa)
12	Data for secondary Option clauses	
X2	Changes in the law	No additional data is required for this Option
X4	Parent company guarantee	No additional data is required for this Option
X7	Delay damages	Amount Per Day
X7.1	Delay damages for Completion of the whole of the <i>works</i> are	1% of the value of the contract sum per day Capped at 5% of the contract sum.
X13	Performance bond	
X13.1	The amount of the performance bond is	20% of the Total Contract Price and expires on commissioning, completion of endurance test and handover of the Stacker Reclaimer 3.
X18	Limitation of liability	

TRANSNET PORT TERMINALS

TENDER NUMBER: TPT/2024/03/0066/60631/RFP

DESCRIPTION OF THE GOODS: SUPPLY OF SERVICES TO REFURBISH STACKER RECLAIMER 3 AT THE SALDANHA IRON ORE TERMINAL FOR TRANSNET SOC LTD (REG.NO.1990/000900/30) OPERATING AS TRANSNET PORT TERMINALS, (HEREINAFTER REFERRED TO AS "TPT"), AS A ONCE OFF SUPPLY.

X18.1	The <i>Contractor's</i> liability to the <i>Employer</i> for indirect or consequential loss is limited to:	An amount being equal to the total Contract Value inclusive of VAT
X18.2	For any one event, the <i>Contractor's</i> liability to the <i>Employer</i> for loss of or damage to the <i>Employer's</i> property is limited to:	An amount being equal to the total Contract Value inclusive of VAT.
X18.3	The <i>Contractor's</i> liability for Defects due to his design which are not listed on the Defects Certificate is limited to:	The cost of correcting the Defect
X18.4	The <i>Contractor's</i> total liability to the <i>Employer</i> for all matters arising under or in connection with this contract, other than excluded matters, is limited to:	An amount being equal to the total Contract Value inclusive of VAT.
X18.5	The <i>end of liability date</i> is	A period being 24 (Twenty Four) consecutive months after the completion by the Contractor of the whole of the works to the Employer in terms of the Contract Five years after the defect date for latent defects.

Z	<i>Additional conditions of contract are:</i>	
Z.1	Obligations in respect of Subcontracting	
Z1.1		It will be a material term of this contract that the <i>Contractor</i> must subcontract a minimum of 30% of the value of the contract.

-
- Z1.2** The *Contractor's* Subcontracting percentage as detailed in the tender submission Returnable T2.2-5 will constitute a binding agreement throughout the duration of the contract until Completion, if not, it will be deemed that the *Contractor* has failed in full to meet the material term of the contract, which may constitute a reason for termination.
- Z1.3** The *Contractor* shall report to the *Employer* on a monthly basis during the term of the Contract, the amounts spent on each sub-contractor.
- Z1.4** Insert addition to Clause 26.2. The *Contractor* may not replace any sub-contractor without acceptance of the *Project Manager*. The *Project Manager* shall before acceptance of a replacement by the *Contractor* of any sub-contractor as detailed in the tender submission Returnable T2.2-5, obtain representations or input from the initial sub-contractor to make an informed decision as to the proposed replacement. The sub-contracting arrangement/contract remains between the *Contractor* and sub-contractor.
- Z1.5** The *Contractor* shall provide to the *Employer*, upon receiving an instruction to do so, any documentation and/or evidence required by the *Employer*, which in the *Employer's* opinion would be necessary to verify whether the *Contractor* has maintained the subcontracting percentage. The *Contractor* shall provide the said documentation and/or evidence within the period stated in the instruction. The provision of the documentation and/or evidence shall not constitute a compensation event.
-

Z2 Local Production and Content Obligations

Z2.1

In terms of Local Production and Content (SBD 6.2), Annexure D and Annexure E of the Annexure B Returnable Schedule T2.2-12 Schedule: Declaration Certificate of Local Production and Content, the *Contractor* has undertaken to fulfil its obligations of the Local Production and Content for the following designated sectors: 1. Electrical Cables 90%; 2. Steel products and Components for Construction 100%; 3. Pulleys 60% ; 4. Rail Rolling Stock (Bougie) 100% ;and 5. Medium Voltage (MV) Motors and Associated 100% .

Z2.2

The *Contractor* is required to note that the *Employer*, the Department of Trade and Industry [DTI] and/or the body appointed by the DTI as the verification authority for local content may conduct compliance audits with regard to the Local Production and Content requirements as prescribed in Regulation 8 of the Preferential Procurement Regulations, 2017 issued in terms of the Preferential Procurement Policy Framework Act no. 5 of 2000.

Z2.3

The *Contractor* is required to continuously update Declarations C, D and E of the Local Production and Content Declaration commitments with the actual local content values for the duration of the contract.

The *Contractor* shall report to the *Employer* on a monthly basis during the term of the Contract, the amounts spend on Local Production and Content for the designated sectors for the duration of the contract.

TRANSNET PORT TERMINALS

TENDER NUMBER: TPT/2024/03/0066/60631/RFP

DESCRIPTION OF THE GOODS: SUPPLY OF SERVICES TO REFURBISH STACKER RECLAIMER 3 AT THE SALDANHA IRON ORE TERMINAL FOR TRANSNET SOC LTD (REG.NO.1990/000900/30) OPERATING AS TRANSNET PORT TERMINALS, (HEREINAFTER REFERRED TO AS "TPT"), AS A ONCE OFF SUPPLY.

Z2.4	The <i>Contractor</i> must refer to Schedule A attached to the Returnable Schedule T2.2-12 Schedule: Declaration Certificate of Local Production and Content concerning non-compliance penalties applicable to Local Production and Content.
Z2.5	Breach of Local Production and Content commitments provides the <i>Employer</i> cause to terminate the contract.

Z4	Additional clause relating to Performance Bonds and/or Guarantees
Z4.1	The Performance Guarantee under X13 above shall be an irrevocable, on-demand performance guarantee, to be issued exactly in the form of the Pro Forma documents provided for this purpose under C1.3 (Forms of Securities), in favour of the <i>Employer</i> by a financial institution reasonably acceptable to the <i>Employer</i>.

**Z5 Additional clauses relating to
Joint Venture****Z5.1****Insert the additional core clause 27.5**

27.5. In the instance that the *Contractor* is a joint venture, the *Contractor* shall provide the *Employer* with a certified copy of its signed joint venture agreement, and in the instance that the joint venture is an 'Incorporated Joint Venture,' the Memorandum of Incorporation, within 4 (four) weeks of the Contract Date.

The Joint Venture agreement shall contain but not be limited to the following:

- **A brief description of the Contract and the Deliverables;**
- **The name, physical address, communications addresses and domicilium citandi et executandi of each of the constituents and of the Joint Venture;**
- **The constituent's interests;**
- **A schedule of the insurance policies, sureties, indemnities and guarantees which must be taken out by the Joint Venture and by the individual constituents;**
- **Details of an internal dispute resolution procedure;**
- **Written confirmation by all of the constituents:**
 - i. **of their joint and several liabilities to the *Employer* to Provide the Works;**
 - ii. **identification of the lead partner in the joint venture confirming the authority of the lead partner to bind the joint venture through the *Contractor's* representative;**

iii. **Identification of the roles and responsibilities of the constituents to provide the Works.**

- **Financial requirements for the Joint Venture:**

iv. **the working capital requirements for the Joint Venture and the extent to which and manner whereby this will be provided and/or guaranteed by the constituents from time to time;**

v. **the names of the auditors and others, if any, who will provide auditing and accounting services to the Joint Venture.**

Z5.2

Insert additional core clause 27.6

27.6. The *Contractor* shall not alter its composition or legal status of the Joint Venture without the prior approval of the *Employer*.

Z6 Additional obligations in respect of Termination

Z6.1

The following will be included under core clause 91.1:

In the second main bullet, after the word 'partnership' add 'joint venture whether incorporate or otherwise (including any constituent of the joint venture)' and

Under the second main bullet, insert the following additional bullets after the last sub-bullet:

- **commenced business rescue proceedings (R22)**
- **repudiated this Contract (R23)**

Z6.2	Termination Table	The following will be included under core clause 90.2 Termination Table as follows:
		Amend "A reason other than R1 – R21" to "A reason other than R1 – R23"
Z6.3		Amend "R1 – R15 or R18" to "R1 – R15, R18, R22 or R23."
Z7	Right Reserved by the Employer to Conduct Vetting through SSA	
Z7.1		The Employer reserves the right to conduct vetting through State Security Agency (SSA) for security clearances of any Contractor who has access to National Key Points for the following without limitations:
		1. Confidential – this clearance is based on any information which may be used by malicious, opposing or hostile elements to harm the objectives and functions of an organ of state.
		2. Secret – clearance is based on any information which may be used by malicious, opposing or hostile elements to disrupt the objectives and functions of an organ of state.
		3. Top Secret – this clearance is based on information which may be used by malicious, opposing or hostile elements to neutralise the objectives and functions of an organ of state.

Z8 Additional Clause Relating to Collusion in the Construction Industry

Z8.1 The contract award is made without prejudice to any rights the *Employer* may have to take appropriate action later with regard to any declared tender rigging including blacklisting.

Z9 Protection of Personal Information Act

Z9.1 The *Employer* and the *Contractor* are required to process information obtained for the duration of the Agreement in a manner that is aligned to the Protection of Personal Information Act.

Z10. Intellectual property

Z10.1 Intellectual property

Intellectual property rights (including patents, copyright, trademarks etc.) rest with the party owning them and the Employer indemnifies the Contractor from any liability arising from infringement of such intellectual property rights.

Z11 Anti – Corruption

In the event that the Contractor is alleged to be, or found by any competent court or Tribunal to be involved in any corrupt, unlawful or illegal activities, or is being investigated for any alleged corrupt, unlawful or illegal activity in relation to Transnet or any other party with whom Contractor does business, or if Transnet learns that:

- a) Improper payments are being or have been made or offered to Transnet officials or any other person by Contractor or those acting on behalf of Contractor with respect to the Services; or**

- b) Contractor or those acting on behalf of Contractor has accepted any payment or benefit, regardless of value, as an improper inducement to award, obtain or retain business or otherwise gain or grant an improper business advantage from or to any other person or entity.**

Transnet reserves the right to terminate the aforementioned awarded contract, by giving immediate written notice to the effect that, all or any Agreements it may have with the Contractor or any and all Awards made Contractor for breach of this clause.

Further in the event of such termination, Contractor shall not be entitled to any further payment, regardless of any activities undertaken or agreements with additional third parties entered into by Contractor prior to such termination; and further.

Contractor shall be liable to Transnet for any actual damages or remedies as provided either in the Agreements that are to be signed or in law.

C1.2 Contract Data

Part two - Data provided by the *Contractor*

The tendering *Contractor* is advised to read both the NEC3 Engineering and Construction Contract - June 2005 (with amendments June 2006 and April 2013) and the relevant parts of its Guidance Notes (ECC3-GN) in order to understand the implications of this Data which the tenderer is required to complete. An example of the completed Data is provided on pages 156 to 158 of the ECC3 Guidance Notes.

Completion of the data in full, according to Options chosen, is essential to create a complete contract.

Clause	Statement	Data
10.1	The <i>Contractor</i> is (Name):	
	Address	
	Tel No.	
	Fax No.	
11.2(8)	The <i>direct fee percentage</i> is	%
	The <i>subcontracted fee percentage</i> is	%
11.2(18)	The <i>working areas</i> are the Site and	
24.1	The <i>Contractor's</i> key persons are:	
	1 Name:	
	Job:	
	Responsibilities:	
	Qualifications:	
	Experience:	
	2 Name:	
	Job	
	Responsibilities:	
	Qualifications:	
	Experience:	

TRANSNET PORT TERMINALS

TENDER NUMBER: TPT/2024/03/0066/60631/RFP

DESCRIPTION OF THE GOODS: SUPPLY OF SERVICES TO REFURBISH STACKER RECLAIMER 3 AT THE SALDANHA IRON ORE TERMINAL FOR TRANSNET SOC LTD (REG.NO.1990/000900/30) OPERATING AS TRANSNET PORT TERMINALS, (HEREINAFTER REFERRED TO AS "TPT"), AS A ONCE OFF SUPPLY.

		CV's (and further key persons data including CVs) are appended to Tender Schedule entitled .		
11.2(14)	The following matters will be included in the Risk Register			
31.1	The programme identified in the Contract Data is			
A	Priced contract with activity schedule			
11.2(20)	The <i>activity schedule</i> is in			
11.2(30)	The tendered total of the Prices is	(in figures) (in words), excluding VAT		
	Data for Schedules of Cost Components	<i>Note "SCC" means Schedule of Cost Components starting on page 60 of ECC, and "SSCC" means Shorter Schedule of Cost Components starting on page 63 of ECC.</i>		
A	Priced contract with activity schedule	Data for the Shorter Schedule of Cost Components		
41 in SSCC	The percentage for people overheads is:	%		
21 in SSCC	The published list of Equipment is the last edition of the list published by			
	The percentage for adjustment for Equipment in the published list is	% (state plus or minus)		
22 in SSCC	The rates of other Equipment are:	Equipment	Size or capacity	Rate

TRANSNET PORT TERMINALS

TENDER NUMBER: TPT/2024/03/0066/60631/RFP

DESCRIPTION OF THE GOODS: SUPPLY OF SERVICES TO REFURBISH STACKER RECLAIMER 3 AT THE SALDANHA IRON ORE TERMINAL FOR TRANSNET SOC LTD (REG.NO.1990/000900/30) OPERATING AS TRANSNET PORT TERMINALS, (HEREINAFTER REFERRED TO AS "TPT"), AS A ONCE OFF SUPPLY.

61	in	The hourly rates for Defined Cost of design outside the Working Areas are	Category of employee	Hourly rate
62	in	The percentage for design overheads is	%	
63	in	The categories of design employees whose travelling expenses to and from the Working Areas are included in Defined Cost are:		

63 in	SSCC	The categories of design employees whose travelling expenses to and from the Working Areas are included in Defined Cost are:		
-------	------	--	--	--

--	--	--	--	--

Technical Evaluation Scorecard for Refurbishment of Stacker Reclaimer 3

iCLM _____

SUPPLY OF SERVICES TO REFURBISH STACKER RECLAIMER 3 AT THE SALDANHA IRON ORE TERMINAL FOR TRANSNET SOC LTD (REG.NO.1990/000900/30) OPERATING AS TRANSNET PORT TERMINALS, (HEREINAFTER REFERRED TO AS "TPT"), AS A ONCE OFF SUPPLY.

Evaluation Criteria	Description	Scoring principal (The returnable schedules contains the details for scoring the points indicated in the column below)	Returnable Schedule	Criteria	Weighting	
Technical & Operational	Quality Management	Contractor to supply the following: - Project Quality Management plan - 4 points - Quality data book index - 1 point - Index/List of procedures and method statements - 10 points - Quality Control Plans - 3 points - Quality Policy - 3 points - Audit Schedule - 1 point Total of 22 points awarded for quality as a sum of the above individually scored areas	T2.2-xx	Completed returnable	22	
	Sub-total				22	
	Organogram & CV's	Organogram - 2 points		T2.2-xx	Completed returnable	2
		Project Manager. Qualifications and experience - 7 points			Completed returnable	7
		Construction Manager. Qualifications and experience - 5 points			Completed returnable	5
		Health and Safety Officers Qualifications and experience - 3 points			Completed returnable	3
		Quality Manager Qualifications and experience - 4 points			Completed returnable	4
		Schedule Manager/Planner Experience - 2 points			Completed returnable	2
		Commissioning Manager Qualifications and experience - 4 points			Completed returnable	4
		Administration/Document Controller Experience - 1 point			Completed returnable	1
Sub-total				28		
Availability of Equipment and other resources	The Tenderer must confirm that the Low bed Truck, Scaffolding, Cranes 120t & 90t, Cherrypicker and Generator will be available for the execution of the works - 5 points	T2.2-xx	Completed returnable	5		
Sub-total				5		
Schedule	- Ability to execute the works in terms of the Employer's requirements - 6 points - Indicating the order and timing of all activities that will take place in order to provide the works in the shortest possible duration - 13 points - At a minimum a Level 2 Programme is developed electronically and submitted in hard and soft copy, in Microsoft Project 2016 format - 1 point Total of 20 points for schedule awarded as a sum of the above individually scored areas	T2.2-xx	Completed returnable	20		
	Sub total			20		
Previous Experience	Substantive experience of a successful refurbishment project of similar works specific to bulk material handling Stackers/Reclaimers: No experience: 0 points One (1) successful refurbishment project of at least R10m within last 10 years: 5 points One (1) successful refurbishment project of at least R20m within last 10 years: 10 points Two (2) successful refurbishment projects of at least R20m within last 10 years: 15 points Three (3) successful refurbishment projects of at least R20m within last 10 years: 20 points At least four (4) successful refurbishment projects of at least R20m within last 10 years: 25 points	T2.2-xx	Completed returnable	25		
	Sub total			25		
TOTAL RATING					100	
Technical Qualification Threshold = 80%.						

NAME: Carols Engelsman, Senior Engineering Manager	NAME: Francois Horton, Programme Manager
SIGNATURE:	SIGNATURE:
DATE	DATE:

Annex D

SENTIAL RETURNABLE DOCUMENT:

Imported Content Declaration - Supporting Schedule to Annex C

(D1) Tender No.	TPT/2024/03/0066/60631/RFP	Note: VAT to be excluded from all calculations
(D2) Tender description:	for the supply of services to refurbish stacker reclaimers 3 at the Saldanha Iron Ore Terminal	
(D3) Designated Products:		
(D4) Tender Authority:		
(D5) Tendering Entity name:		
(D6) Tender Exchange Rate:	Pula	EU R 9,00 GBP R 12,00

A. Exempted imported content

A. Exempted imported content				Calculation of imported content						Summary	
Tender item no's	Description of imported content	Local supplier	Overseas Supplier	Foreign currency value as per Commercial Invoice	Tender Exchange Rate	Local value of imports	Freight costs to port of entry	All locally incurred landing costs & duties	Total landed cost excl VAT	Tender Qty	Exempted imported value
(D7)	(D8)	(D9)	(D10)	(D11)	(D12)	(D13)	(D14)	(D15)	(D16)	(D17)	(D18)
(D19) Total exempt imported value										R 0	

This total must correspond with Annex C - C 21

B. Imported directly by the Tenderer

B. Imported directly by the Tenderer				Calculation of imported content						Summary	
Tender item no's	Description of imported content	Unit of measure	Overseas Supplier	Foreign currency value as per Commercial Invoice	Tender Rate of Exchange	Local value of imports	Freight costs to port of entry	All locally incurred landing costs & duties	Total landed cost excl VAT	Tender Qty	Total imported value
(D20)	(D21)	(D22)	(D23)	(D24)	(D25)	(D26)	(D27)	(D28)	(D29)	(D30)	(D31)
(D32) Total imported value by tenderer										R 0	

C. Imported by a 3rd party and supplied to the Tenderer

C. Imported by a 3rd party and supplied to the Tenderer				Calculation of imported content						Summary	
Description of imported content	Unit of measure	Local supplier	Overseas Supplier	Foreign currency value as per Commercial Invoice	Tender Rate of Exchange	Local value of imports	Freight costs to port of entry	All locally incurred landing costs & duties	Total landed cost excl VAT	Quantity imported	Total imported value
(D33)	(D34)	(D35)	(D36)	(D37)	(D38)	(D39)	(D40)	(D41)	(D42)	(D43)	(D44)
(D45) Total imported value by 3rd party										R 0	

D. Other foreign currency payments

D. Other foreign currency payments				Calculation of foreign currency payments		Summary of payments	
Type of payment	Local supplier making the payment	Overseas beneficiary	Foreign currency value paid	Tender Rate of Exchange	Local value of payments		
(D46)	(D47)	(D48)	(D49)	(D50)	(D51)		
(D52) Total of foreign currency payments declared by tenderer and/or 3rd party							

Signature of tenderer from Annex B

Date: _____

(D53) Total of imported content & foreign currency payments - (D32), (D45) & (D52) above R 0

This total must correspond with Annex C - C 23

Annex E

**ESSENTIAL RETURNABLE DOCUMENT:
FAILURE TO FULLY COMPLETE, DECLARE, SIGN & DATE THIS ANNEXURE E MAY RESULT IN THE BID BEING NON-RESPONSIVE & DISQUALIFIED**

Local Content Declaration - Supporting Schedule to Annex C

<i>(E1)</i>	Tender No.	TPT/2024/03/0066/60631/RFP
<i>(E2)</i>	Tender description:	for the supply of services to refurbish stacker reclaimer 3 at the Saldanha Iron Ore Terminal
<i>(E3)</i>	Designated products:	
<i>(E4)</i>	Tender Authority:	
<i>(E5)</i>	Tendering Entity name:	

Note: VAT to be excluded from all calculations

Local Products (Goods, Services and Works)	Description of items purchased	Local suppliers	Value
	<i>(E6)</i>	<i>(E7)</i>	<i>(E8)</i>
<i>(E9)</i> Total local products (Goods, Services and Works)			R 0

<i>(E10)</i>	Manpower costs (Tenderer's manpower cost)	R 0
<i>(E11)</i>	Factory overheads (Rental, depreciation & amortisation, utility costs, consumables etc.)	R 0
<i>(E12)</i>	Administration overheads and mark-up (Marketing, insurance, financing, interest etc.)	R 0
<i>(E13)</i> Total local content		R 0

This total must correspond with Annex C - C24

Signature of tenderer from Annex B

Date: _____

Annex C

RETURNABLE DOCUMENT:

Local Content Declaration - Summary Schedule

<i>(C1)</i>	Tender No.	TPT/2024/03/0066/60631/RFP
<i>(C2)</i>	Tender description	for the supply of services to refurbish stacker reclaimer 3 at the Saldanha Iron Ore Terminal
<i>(C3)</i>	Designated product(s)	
<i>(C4)</i>	Tender Authority:	
<i>(C5)</i>	Tendering Entity name:	
<i>(C6)</i>	Tender Exchange Rate:	
<i>(C7)</i>	Specified local content %	

Note: VAT to be excluded from all calculations

Pula EU GBP

Calculation of local content							
Tender item no's	List of items	Tender price - each (excl VAT)	Exempted imported value	Tender value net of exempted imported content	Imported value	Local value	Local content % (per item)
<i>(C8)</i>	<i>(C9)</i>	<i>(C10)</i>	<i>(C11)</i>	<i>(C12)</i>	<i>(C13)</i>	<i>(C14)</i>	<i>(C15)</i>
1	Steel Products and Components for Construction						
2	Electrical Cables						
3	Bogie						
4	Medium Voltage Electric Motors						
5	Pulleys						

Tender summary			
Tender Qty	Total tender value	Total exempted imported content	Total Imported content
<i>(C16)</i>	<i>(C17)</i>	<i>(C18)</i>	<i>(C19)</i>

<i>(C20)</i> Total tender value	R 0
<i>(C21)</i> Total Exempt imported content	R 0
<i>(C22)</i> Total Tender value net of exempt imported content	R 0
<i>(C23)</i> Total Imported content	R 0
<i>(C24)</i> Total local content	R 0
<i>(C25)</i> Average local content % of tender	

Signature of tenderer from Annex B

Date: _____

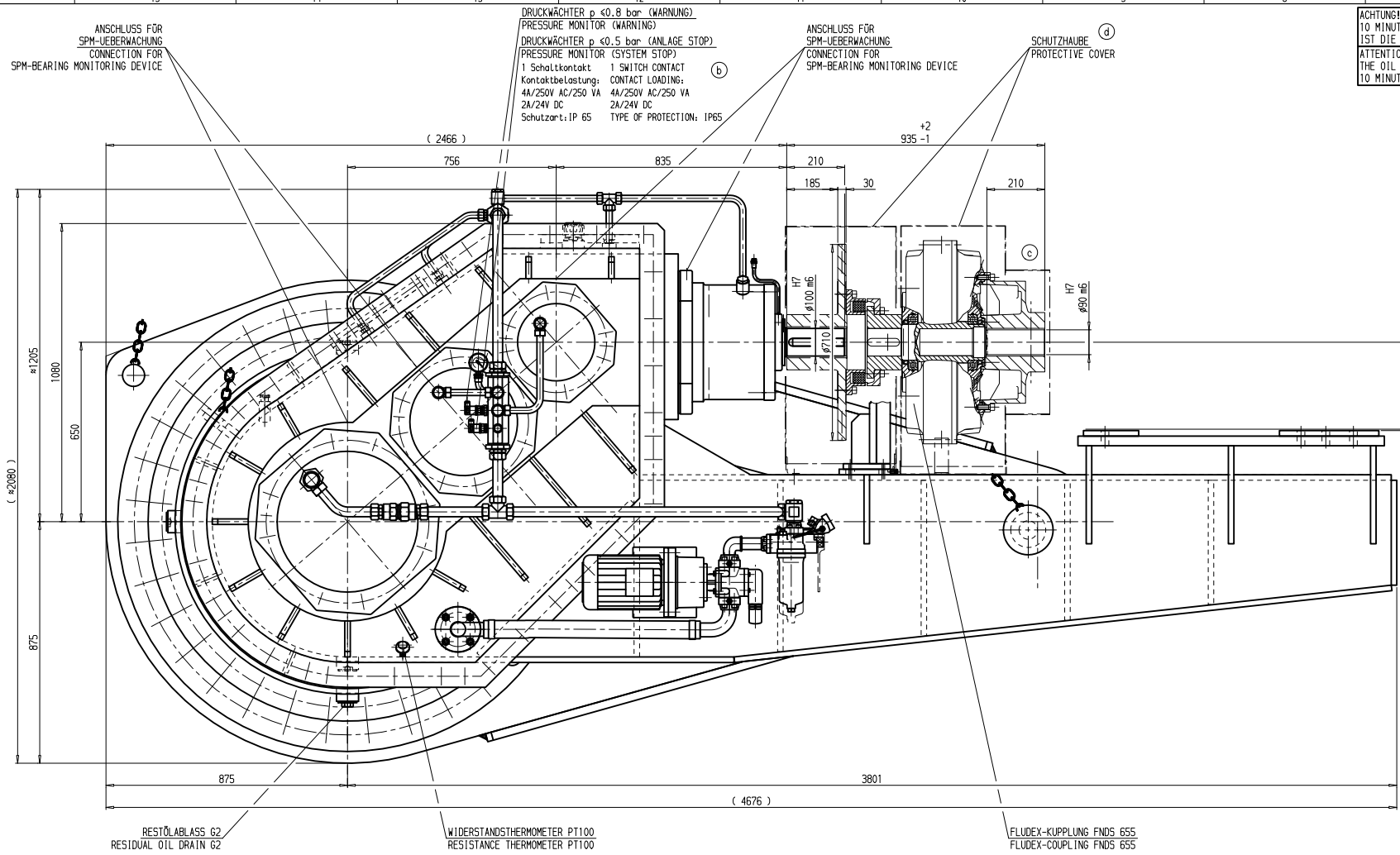

ACHTUNG! 10 MINUTEN VOR INBETRIEBNAHME DES GETRIEBES IST DIE ÖLPUMPE EINZUSCHALTEN
ATTENTION THE OIL PUMP MUST BE SWITCHED ON 10 MINUTES BEFORE STARTING UP THE GEAR UNIT

WEIGHT * GEWICHT *	GEWICHT *	GEWICHT *
GEAR UNIT GETRIEBE	≈ 15653 kg	
TORQUE ARM DREHMOMENTSTUETZE	≈ 1670 kg	
SHRINK-DISC SCHRUMPFSCHEIBE	≈ 1577 kg	
PROTECTIVE COVER SCHUTZHAUBE	≈ 90 kg	
FLUDEX-COUPLING FLUDEX-KUPPLUNG	≈ 425 kg	
DISC BRAKE SCHEIBENBREMSE	≈ 81 kg	
TOTAL GESAMT	≈ 19496 kg	

TECHNISCHE DATEN - GETRIEBE TECHNICAL DATA - GEAR UNIT		
TYPE	BAUART	PBUC
SIZE	GRÖÖE	32
DESIGN	AUSFÜHRUNG	B
INSTALLED POWER	INSTALLIERTE LEISTUNG	PM 355 kW
NOMINAL OUTPUT TORQUE	ABTRIEBSNENNMOMENT	T2 786,470 Nm
INPUT SPEED	ANTRIEBSDREHZAH	n1 1426 1/min
OUTPUT SPEED	ABTRIEBSDREHZAH	n2 4,15 1/min
EXACT RATIO	ÜBERSETZUNG	i ist 343,710
OIL QUANTITY	ÖLMENGE	≈... L
OIL VISCOSITY	ÖLVISKOSITÄT	ISO VG 320 Min-ÖIL
AMBIENT TEMPERATURE	UMGEBUNGSTEMPERATUR	+ 5°C - +45°C

ACHTUNG MIN-ÖIL MOTORPUMPE DARF ERST BEI EINER ÖLTEMPERATUR VON > +5°C EINGESCHALTET WERDEN BEI ÖLTEMPERATUREN VON < +5°C IST DAS GETRIEBE EXTERN AUFZUHEIZEN
ATTENTION MIN-OIL MOTOR PUMP MAY BE SWITCHED ON ONLY AT AN OIL TEMPERATURE OF > +5°C AT AN OIL TEMPERATURE OF < +5°C THE GEAR UNIT MUST BE HEATED EXTERNAL OUTSIDE

Unlaufende Teile müssen vom Käufer gegen unbeabsichtigtes Berühren gesichert werden! (Gesetz über technische Arbeitsmittel)
The purchaser is responsible for the provision of safety guards.

Passfedern nach DIN 6885-1, Leichter Sitz und Zentrierung(en) nach DIN 332, Form DS
Parallel keyway(s) to DIN 6885-1, Light seating and centering(s) to DIN 332, shape DS

Gleichartige Pfeile kennzeichnen die Abhängigkeit der Drehrichtungen!
Arrows show relative directions of rotation

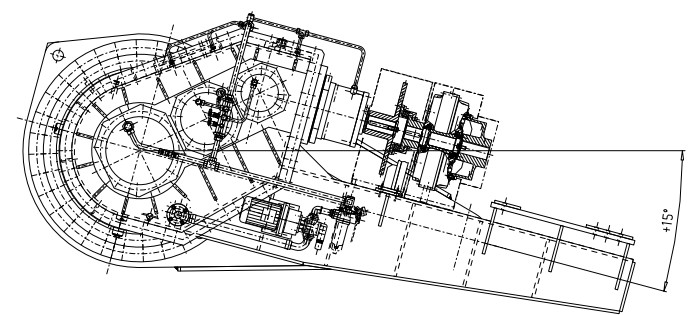
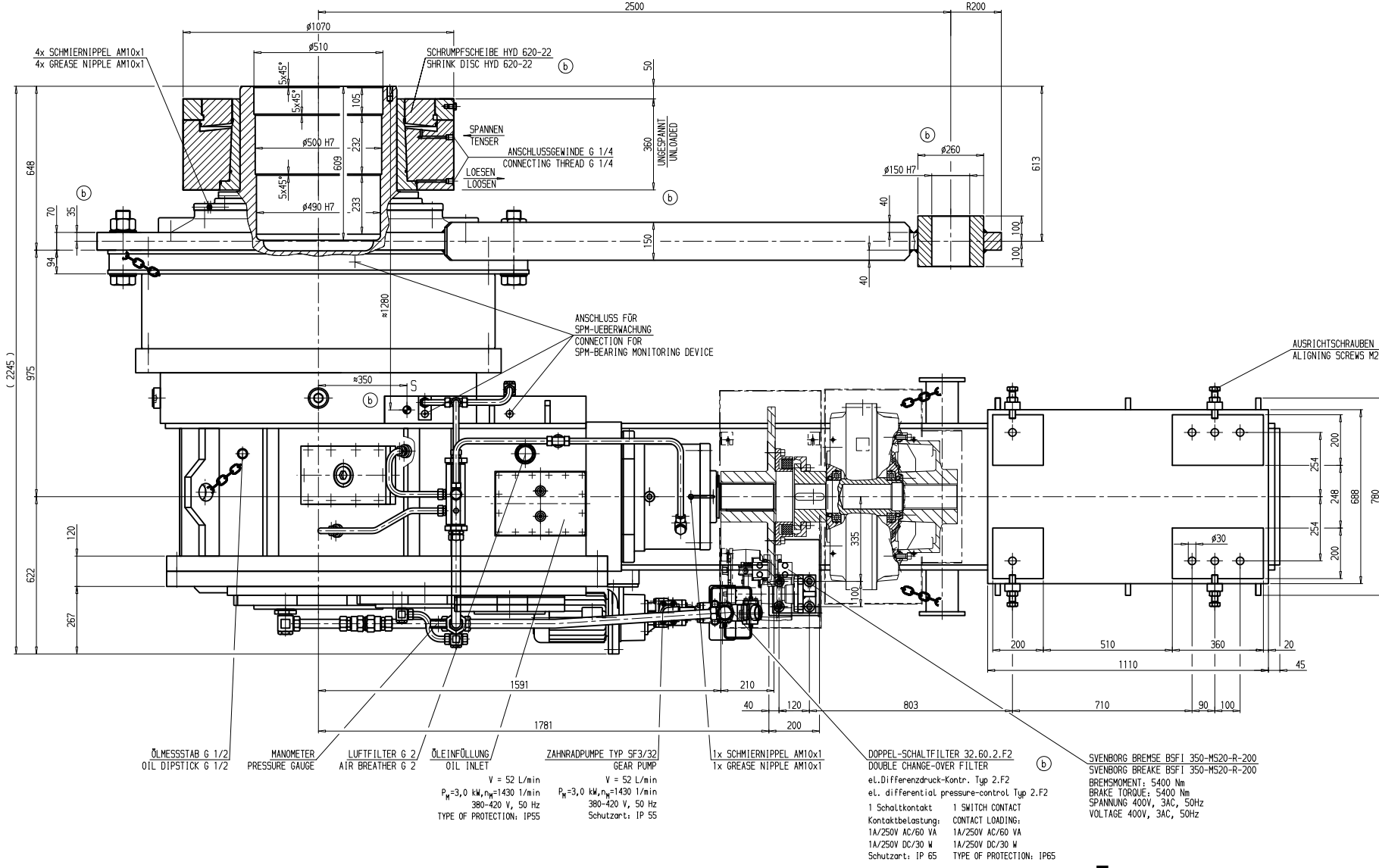
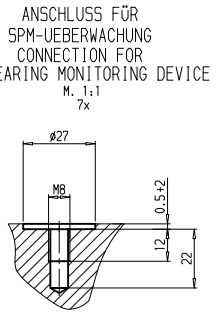
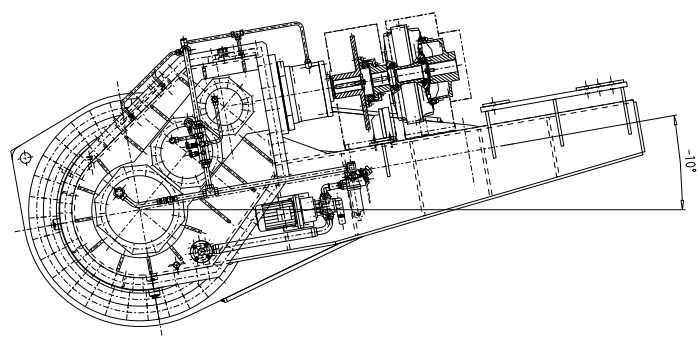

ABMESSUNGEN AM WELLENDE DER ANZUTRIEBENDEN ARBEITSMASCHINE
DIMENSIONS ON SHAFTEND OF DRIVEN MACHINE

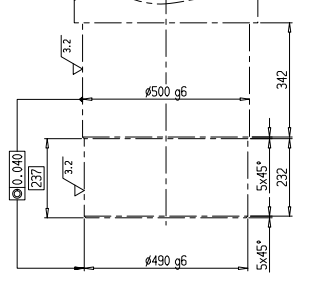

500 g6	-0,020 -0,060	d M8 Schutzhabe geändert	2007-12-12	NEJ	BAC	2007-12-14
500 H7	+0,063 0	c K10 Kupplungsdarstellung und Gewicht geändert	2007-11-08	ETG		2007-11-08
490 g6	-0,020 -0,060	b 9x Schwerpunkt, techn. Daten u. Maße hinzu, Schrauben u. Gewicht ges., Schrupfscheibe kor.	2007-07-03	NEJ	BAC	2007-07-04
490 H7	+0,063 0	a - Zeichnung ergänzt	2007-06-20	ETG		2007-06-20
150 H7	+0,040 0	Rev Zone Description/Änderungsbeschreibung	Date Name	Date Name		
100 m6	+0,035 +0,013	Order No. 4335769/100	Archived	Tolerancing ISO 8015 General tolerances for machining $\pm 0,3$ otherwise ISO 2768-mH Tolerierung ISO 8015 ALLgemeintoleranzen für mech. Bearbeitung $\pm 0,3$ sonst ISO 2768-mH		
100 H7	+0,035 0	Surfaces not specified:		Drawn HD 2007-06-15	Euting	
90 m6	+0,035 +0,013	Roughness Ra in μm		Chkd HD 2007-06-15	Bachler	
90 H7	+0,035 0	Dept Date		Name of Part/Benennung Key No.: 0290		
Padmaß BASIC SIZE DEVIATIONS		Scale 1:8		Weight (kg)		Size type Drawing No./Zeichnungs-Nr.
Toleranzen TOLERANCES		Mass mom. of inertia J (kgm ²)		Supersedes		5 M 6 143 714 d
Dimensions in mm		Part		From dwg 6 143 487		Rev.
				Observe protection marks/Schutzvermerk ISO 15011		

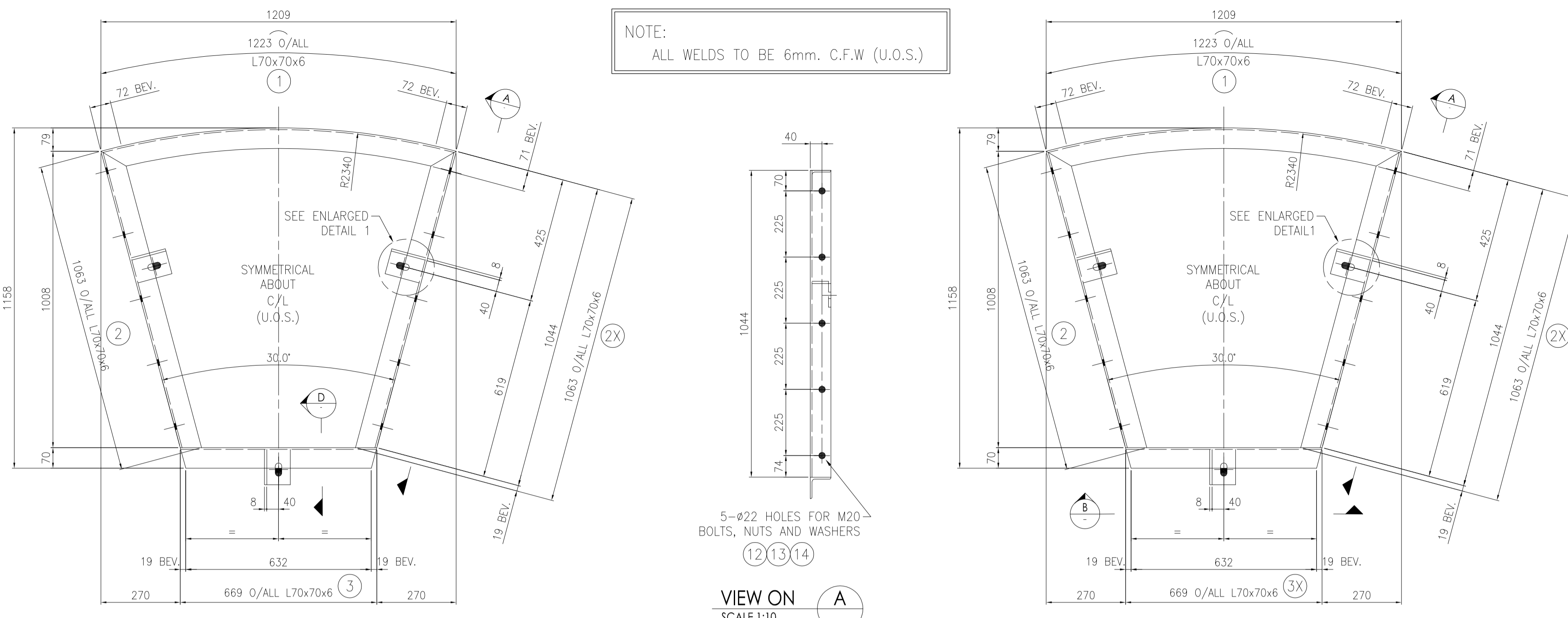

ELEVEN - FRAMES REQUIRED AS DRAWN MARKED "FR1"

ONE - FRAME REQUIRED AS DRAWN MARKED "FR2"

ITEM NO.	WT. (kg)	QTY.	MATERIAL	DESCRIPTION	LENGTH
1	7.8	12	SANS 1431-350WA	L70x70x6	1223
2	6.8	12	SANS 1431-350WA	L70x70x6	1063
2X	6.8	12	SANS 1431-350WA	L70x70x6	1063
3	4.3	11	SANS 1431-350WA	L70x70x6	669
3X	4.3	11	SANS 1431-350WA	L70x70x6	669
4	12.7	1	SANS 1431-350WA	L100x75x6	1574
5	0.6	36	SANS 1431-350WA	PLT8x80	120
6	0.5	35	SANS 1431-350WA	PLT8x56	120
7	0.3	1	SANS 1431-350WA	PLT8x40	120
8	5.5	1	SANS 1431-350WA	PLT10x211	327
9	4.9	1	SANS 1431-350WA	PLT10x208	296
10	5.1	12	SANS 1431-350WA	PLT8x130	623
11	34.6	12	OPEN GRID GRATING SERRATED RS40-30x4.5mm B/BARS (SEE NOTES)	GRATING 1136	1185
12	0.20	101	DIN 933 CLASS 8.8	HEX. HD. SET SCREW	M20x70Lg
13	0.05	101	DIN 934 CLASS 8	HEX. NUT	M20
14	0.02	101	DIN 125 A	FLAT WASHER	Ø20

GRATING NOTE:

- 1.) GRATING TO BE OPEN GRID FLOORING SERATED RS40 WITH 30x4.5mm BEARER BARS
- 2.) GRATING TO HAVE SERRATED TOP.
- 3.) FLOORING TO BE FULLY BANDED.
- 4.) FLOORING TO BE HOT DIPPED GALVANIZED TO EN ISO 1461.
- 5.) FLOORING TO BE FIXED WITH SADDLE CLIPS (MIN. 4 PER PANEL, BUT SUPPLY EXTRA 7 PER PANEL = 11 PER PANEL) - SUPPLIED BY GRATING MANUFACTURER.
- 6.) KICK PLATES WELDED TO GRATING TO BE HOT DIPPED GALVANIZED TO EN ISO 1461 AND PAINTED TO SAME COLOR AS THE HAND RAILING.
- 7.) DENOTES THE SPAN OF GRATING

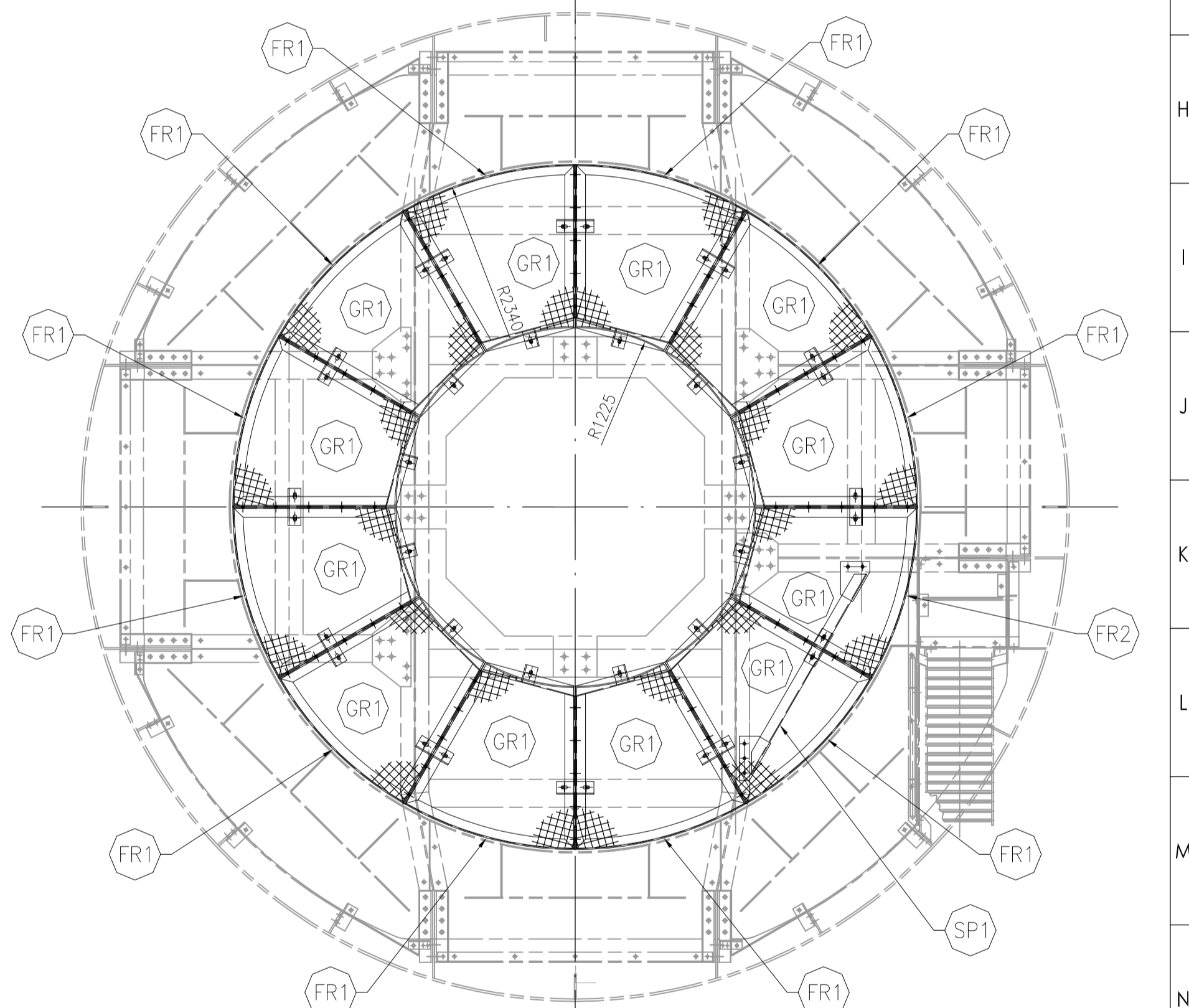
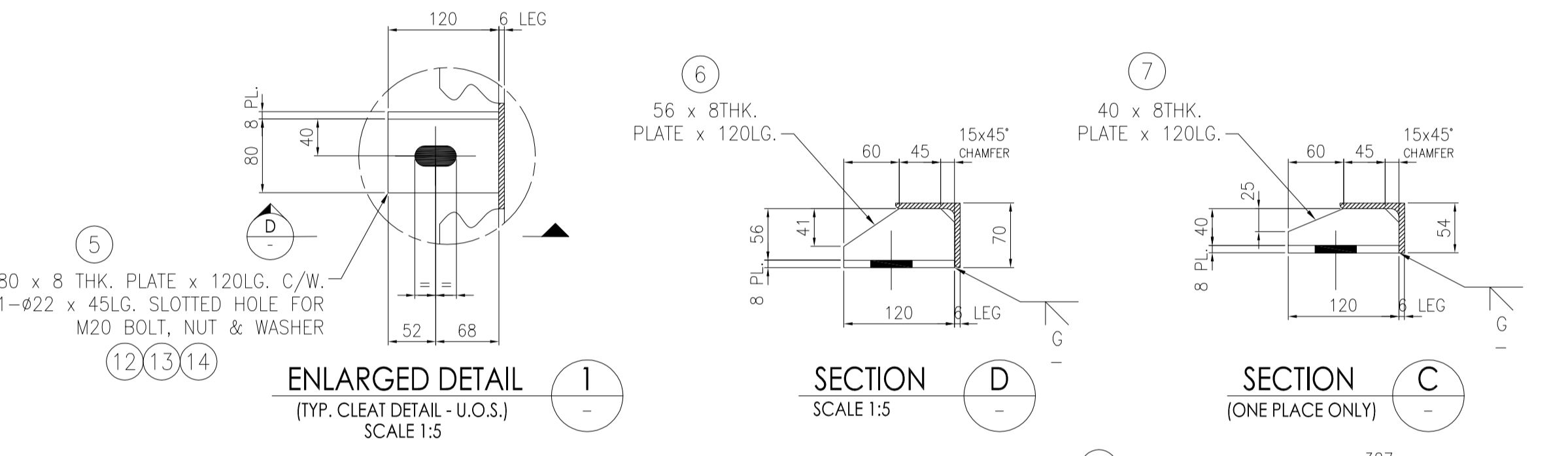

PART PLAN VIEW ON STACKER/RECLAIMER - SHOWING ADDITIONAL GRATING ADDED

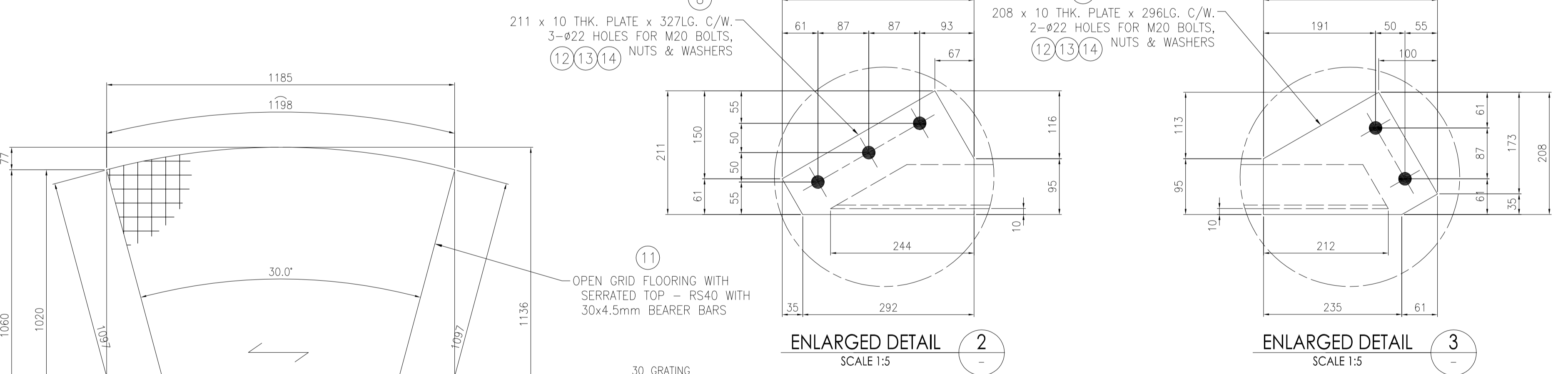

TWELVE - GRATING PANELS REQUIRED AS DRAWN MARKED "GR1"

ONE - SUPPORT REQUIRED AS DRAWN MARKED "SP1"

NOTE:
SITE TO DETERMINE IF SUPPORT FRAMES MUST BE BOLTED TO EXISTING STRUCTURE, ALTERNATIVELY THESE FRAMES CAN BE CLIPPED TO EXISTING STEELWORK WITH EXTRA GRATING CLIPS

0	WPI	AF	15.09.2020	ISSUED FOR CONSTRUCTION
Drawn	Appr.	Apr. Date	Zone/Description	
Scale: A/S	Language Rev:			
SALDANHA BAY STACKER RECLAIMER SR2 CENTER FSTOON GRATING				
SHOP DETAILS ADDITIONAL SUPPORT FRAMES AND GRATING				
Mat.: N/A	Weight: 875 kg	Welds: N/A	Based on: N/A	ISO-A
Replacing: N/A			Sheet 1 of 1	
<small>Property of FLsmidth A/S. This drawing contains confidential, proprietary, and/or trade secret information of FLsmidth A/S. The drawing and/or the information contained therein, may only be used for the limited purposes of evaluating, proposing, installing, operating or maintaining FLsmidth equipment. Disclosure, distribution, duplication, modification, or other use of this drawing and/or the information therein is not permitted without the prior written permission of FLsmidth A/S © 2012. FLsmidth A/S. All rights reserved.</small>				
FLSMIDTH No.: 639-18694-B2			A1	Content Rev.: 0

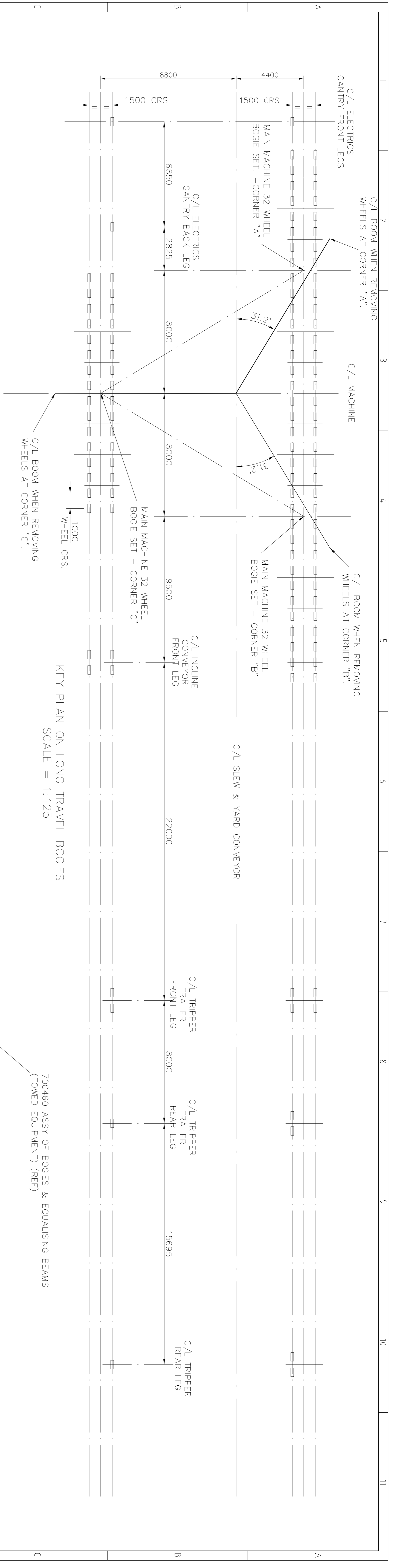

KEY PLAN ON LONG TRAVEL BOGIES
SCALE = 1:125

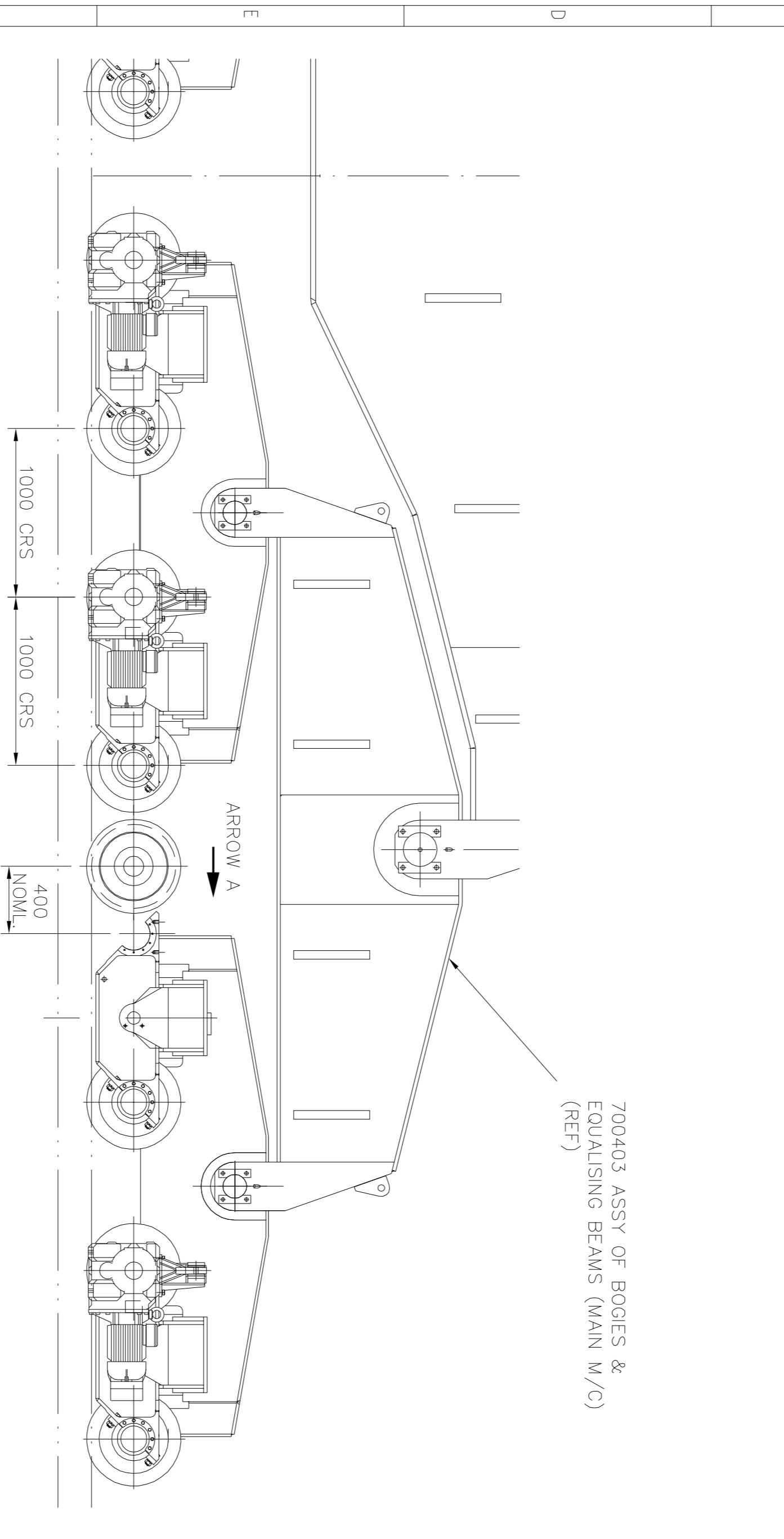

ENLARGED VIEW OF MAIN MACHINE BOGIE JACKING
SCALE = 1:25

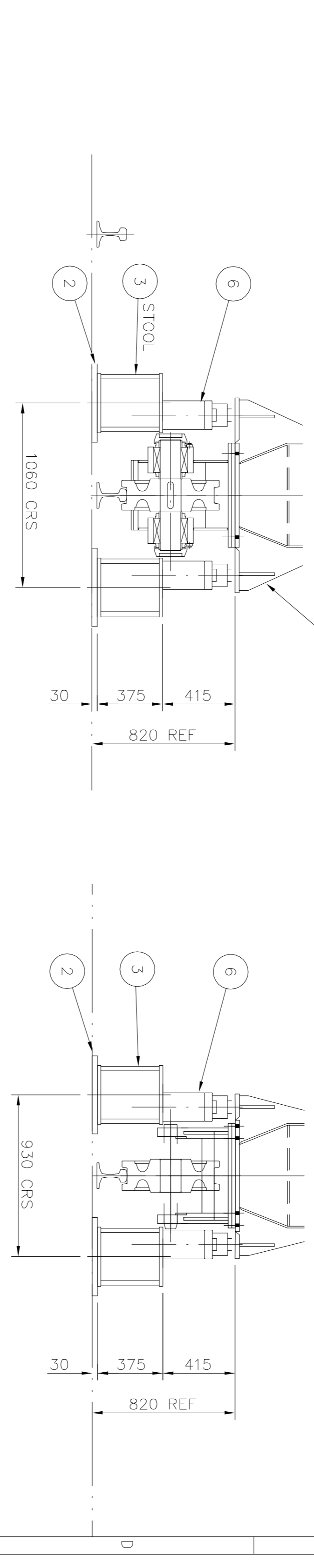

ENLARGED VIEW OF SINGLE WHEEL JACKING
TYPICAL 5 POSITIONS
SCALE = 1:20

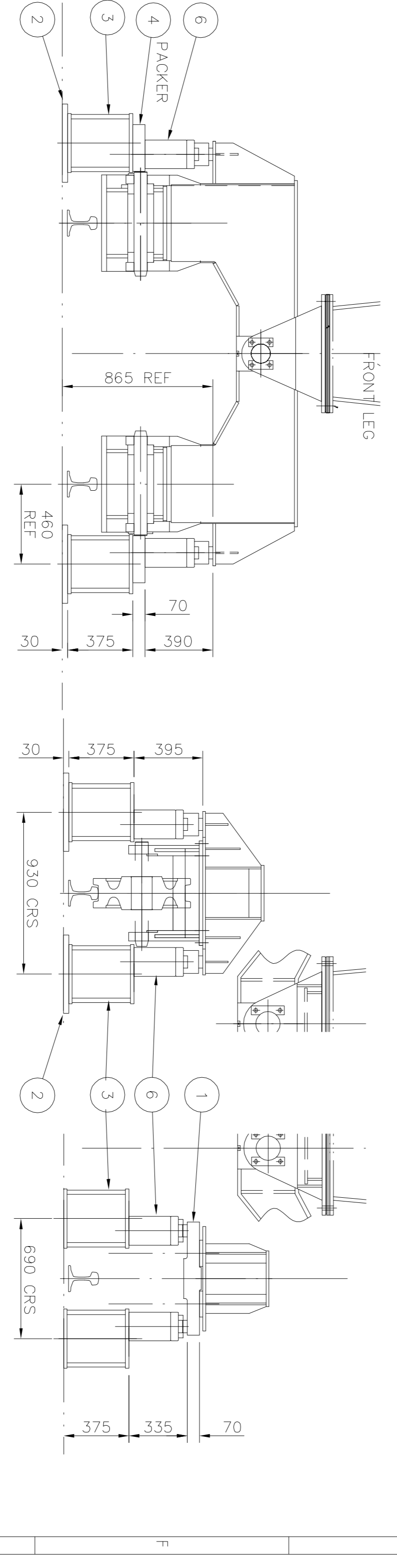

ENLARGED VIEW OF 2 WHEEL BOGIE JACKING
TYPICAL 3 POSITIONS
SCALE = 1:20

ENLARGED VIEW OF MAIN MACHINE BOGIE JACKING
SCALE = 1:25

1	CHECKED	DATE	DRAWN	CHECKED	DATE	DRAWN	CHECKED	DATE	DRAWN	CHECKED	DATE	DRAWN	CHECKED	DATE	DRAWN	CHECKED	DATE	DRAWN	CHECKED	DATE	DRAWN	CHECKED	DATE
1																							

ISSUES RAISED	GENUPDATE	AS BUILT	FIRST ISSUE					
DRAWN	DDB	CHECKED	RD	CHECKED	DATE	19.04.06	22.6.06	22.6.06
APPROVED	JWH	APPROVED	JWH	APPROVED	DATE	26.FEB.03	13.MAR.03	17.MAR.03

DO NOT SCALE
IF IN DOUBT - ASK

metso minerals

SALDANHA BAY STACKER RECLAIMER
ASSY & DTLS OF MAINTENANCE EQUIPMENT.

TITLE: SALDANHA BAY STACKER RECLAIMER ASSY & DTLS OF MAINTENANCE EQUIPMENT.

THIS DRAWING IS THE PROPERTY OF METSO MINERALS. IT IS LOANED TO YOU FOR THE SPECIFIC PROJECT AND MUST NOT BE REPRODUCED OR USED IN ANY WAY THAT IS NOT AUTHORIZED BY METSO MINERALS. IF YOU ARE NOT THE ORIGINAL ADDRESSEE OF THIS DRAWING, PLEASE RETURN IT TO THE ADDRESSEE. IF YOU ARE THE ORIGINAL ADDRESSEE, PLEASE DESTROY THIS DRAWING WHEN IT IS NO LONGER NEEDED.

MASS	1475kg	ORIGINAL SCALE	1:125 UOS	SIZE	A1	DRAWING NUMBER	700399	SHEET OF	1 3	ISSUE	B
------	--------	----------------	-----------	------	----	----------------	--------	----------	-----	-------	---

metso minerals

SOUTH AFRICAN PORT OPERATIONS
IRON ORE TERMINAL - SALDANHA
STACKER RECLAIMER CONTRACT HQH375
SANCTION No. SB01 D1

METSO MINERALS (UK) LTD
BULK MATERIALS HANDLING BRISTOL
PO BOX 821 ASHTON VALE RD
BRISTOL BS599 5ZB ENGLAND

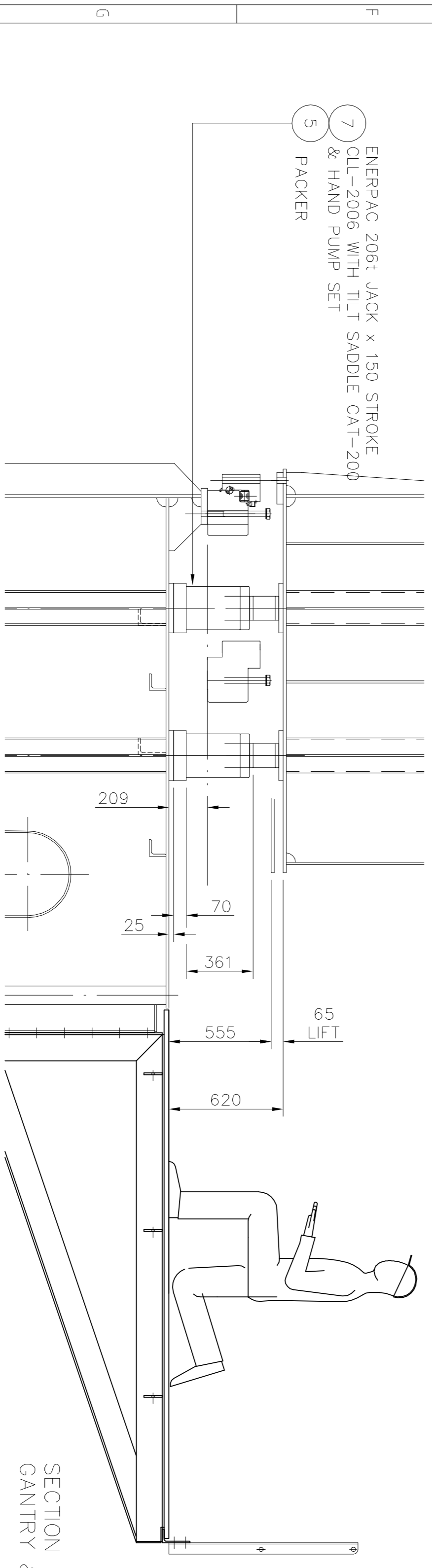
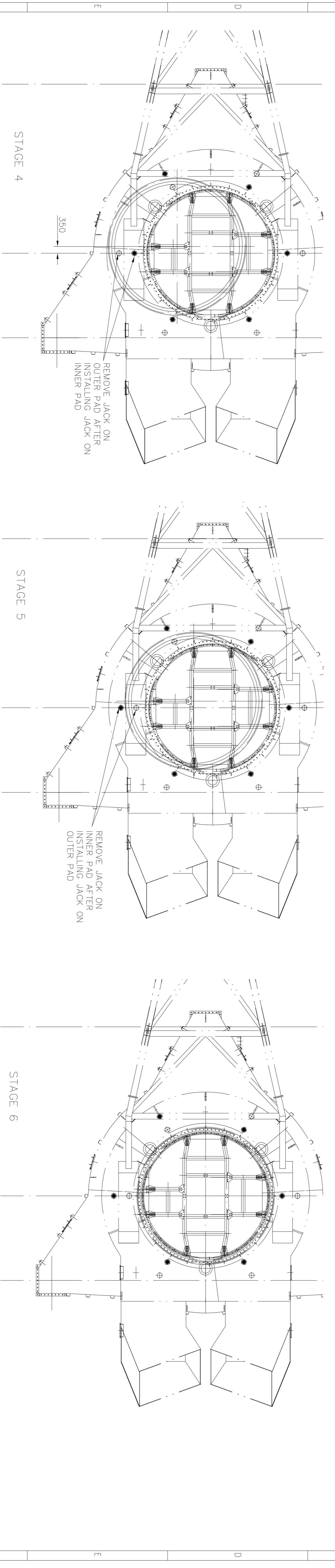
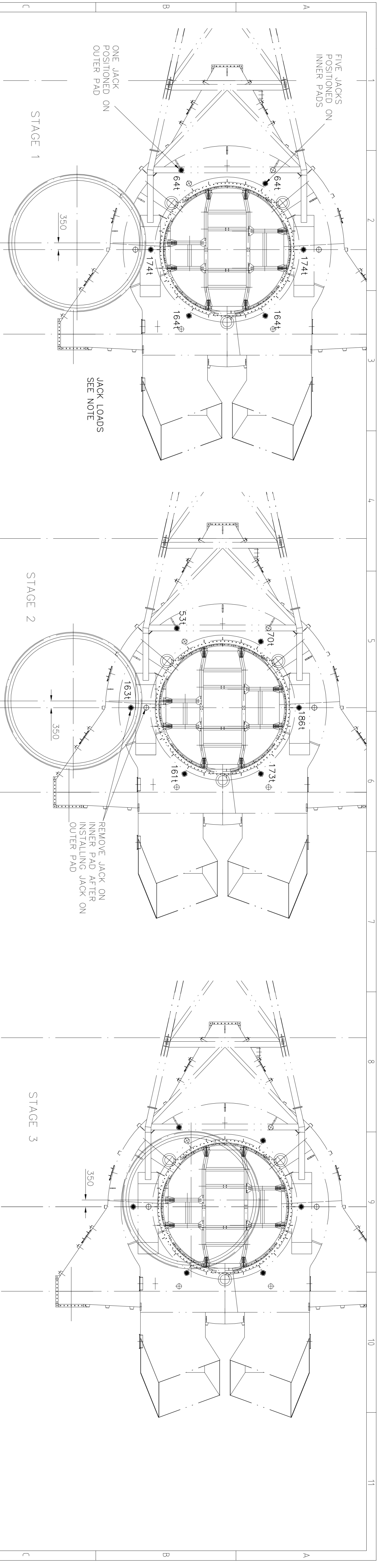

ENERPAC 206t JACK x 150 STROKE
 CLL-2006 WITH TILT SADDLE CAT-200
 & HAND PUMP SET
 7
 5
 PACKER

SECTION THROUGH
 GANTRY & SLEWDECK

DATE	CHECKED	APPROVED	DATE	CHECKED	APPROVED	DATE	CHECKED	APPROVED	DATE	CHECKED	APPROVED	DATE	CHECKED	APPROVED	DATE	CHECKED	APPROVED
19.04.06	DDB	JWH	22.6.06	JWH	JWH	26.FEB.03	JWH	GMB	17.MAR.03	JWH							

ISSUES RAISED GEN UPDATE AS BUILT

FIRST ISSUE

UNLESS OTHERWISE SPECIFIED IDENTIFY THE ITEM WITH THE DRAWING NUMBER AND ISSUE LEVEL AT AND IN THE MANNER SHOWN FOR PAINTING AND FOR LUBRICATION SPECIFICATIONS SEE COMPONENTS LIST.

TOLERANCES UNLESS OTHERWISE STATED (PLUS OR MINUS)

RANGE	MACH	FAB	CAST
0-500	0.5	2	2
501-1000	0.5	3	4
1001-2000	1.0	4	6
ABOVE 2000	2.0	6	10

THIS DRAWING IS THE PROPERTY OF METSO MINERALS. Bulk Materials Handling Bristol and must not be made public, copied or used in any way detrimental to our interest. It is loaned subject to return on demand unless furnished under contract provisions.

DO NOT SCALE
 IF IN DOUBT - ASK

THIRD ANGLE
 WELD SYMBOLS TO BS EN 22553
 SURFACE TEXTURE TO BS EN 12181
 MATERIAL & CONDITION BEFORE MANUFACTURE

MAINT

SPEC

GRADE

NOTES

MASS 1475Kg

ORIGINAL SCALE 1:100 & 20

SIZE A1

DRAWING NUMBER 700399

SHEET OF 3

ISSUE B

SOUTH AFRICAN PORT OPERATIONS
 IRON ORE TERMINAL - SALDANHA
 STACKER RECLAIMER CONTRACT HQH375
 SANCTION No. SB01 D1

METSO MINERALS (UK) LTD
 BULK MATERIALS HANDLING BRISTOL
 PO BOX 821 ASHTON VALE RD
 BRISTOL BS99 5ZB ENGLAND

TITLE
 SALDANHA BAY STACKER RECLAIMER
 ASSY & DETAILS OF MAINTENANCE
 EQUIPMENT

THIS DRAWING TO BE READ IN CONJUNCTION WITH O&M MANUAL.

- REFER TO DRAWING 700422, A + D SLEW RING & SLEW DRIVES, FOR CORRECT ORIENTATION OF 2x SLEW RING SOFT SPOTS.
- JACK LOADS ARE ESTIMATES BASED ON DEAD LOAD OF SLEWING STRUCTURE AND MATERIAL ON BELT.
 (0.7 TONNE/m = 41 TONNES @27.6m FROM LUFF PIVOT)

IMPORTANT!
 BELT MUST BE LOADED AS ABOVE TO OBTAIN THE CORRECT BALANCE FOR JACKING.
 3. NOTE SLEW POSITION OF BOOM FOR MAIN MACHINE BOGIE JACKING.
 (BOOM TO BE UNLOADED FOR BOGIE JACKING)

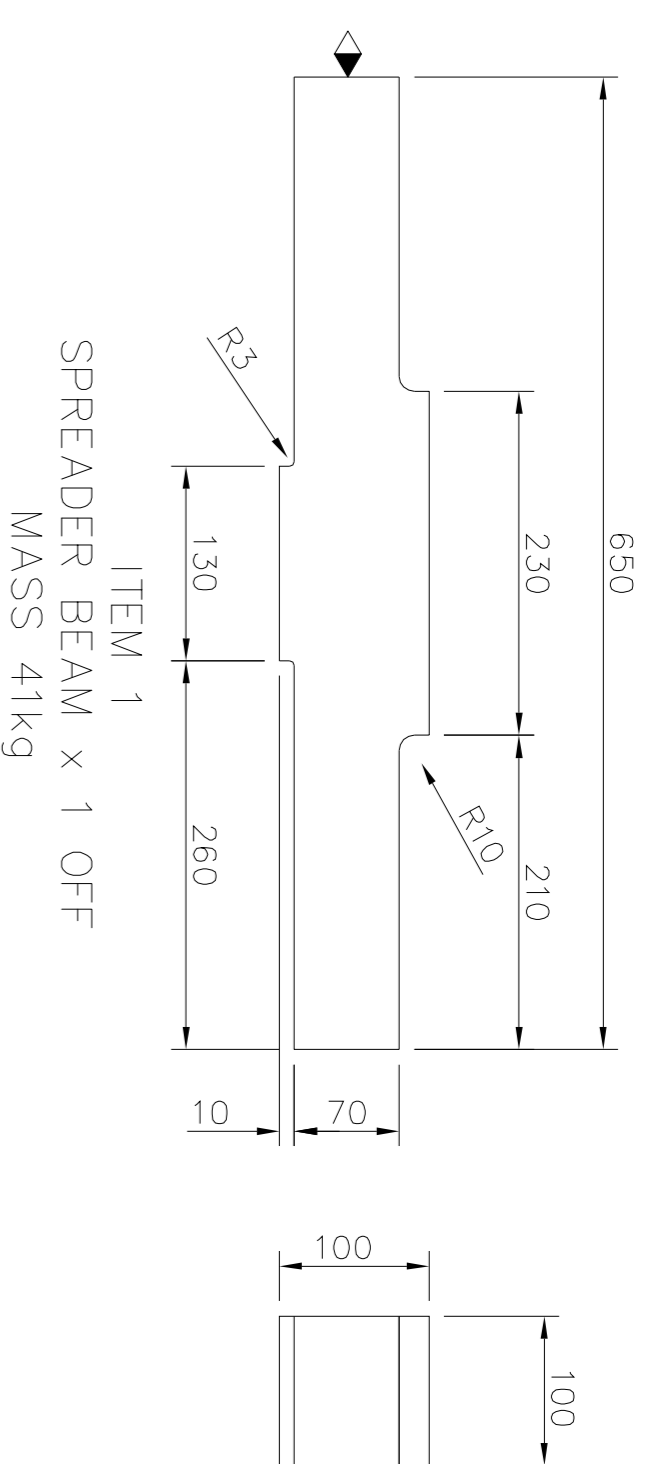

ITEM 1
SPREADER BEAM x 1 OFF
MASS 41kg

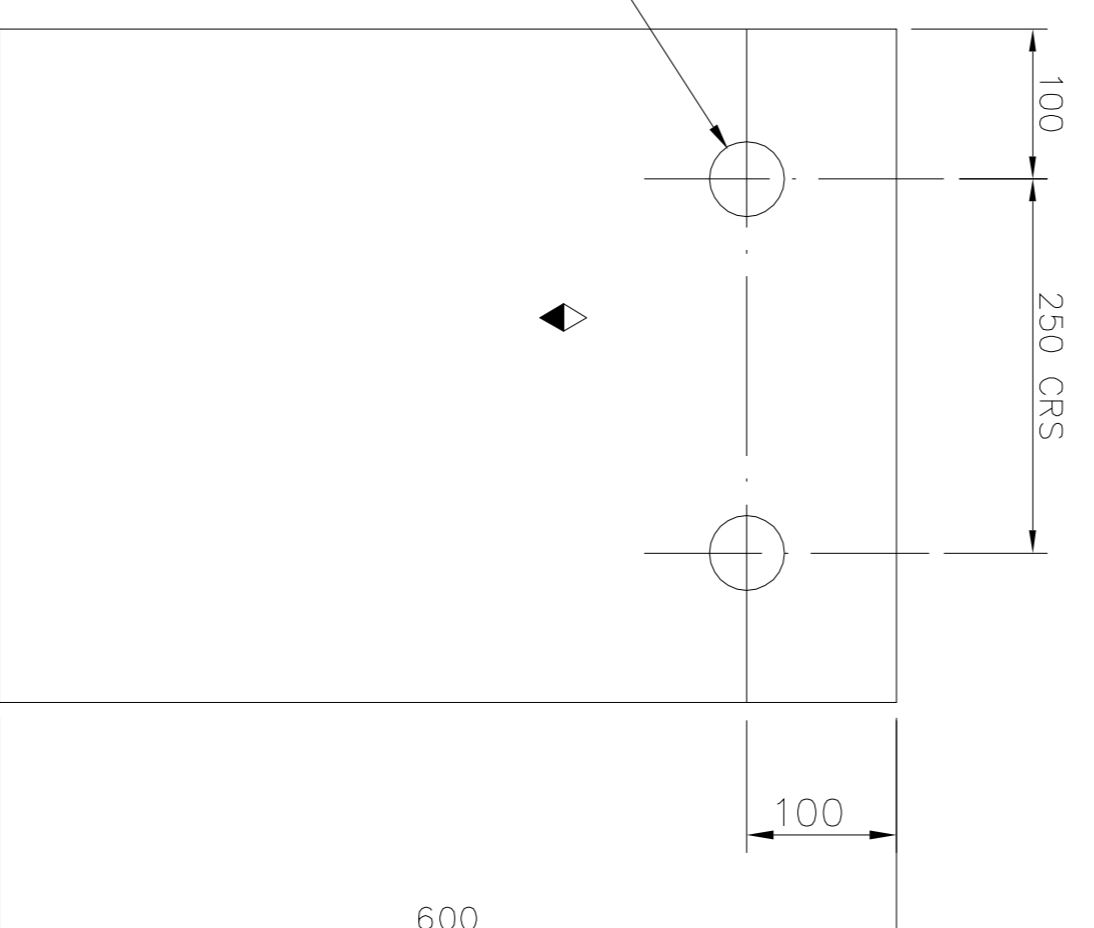
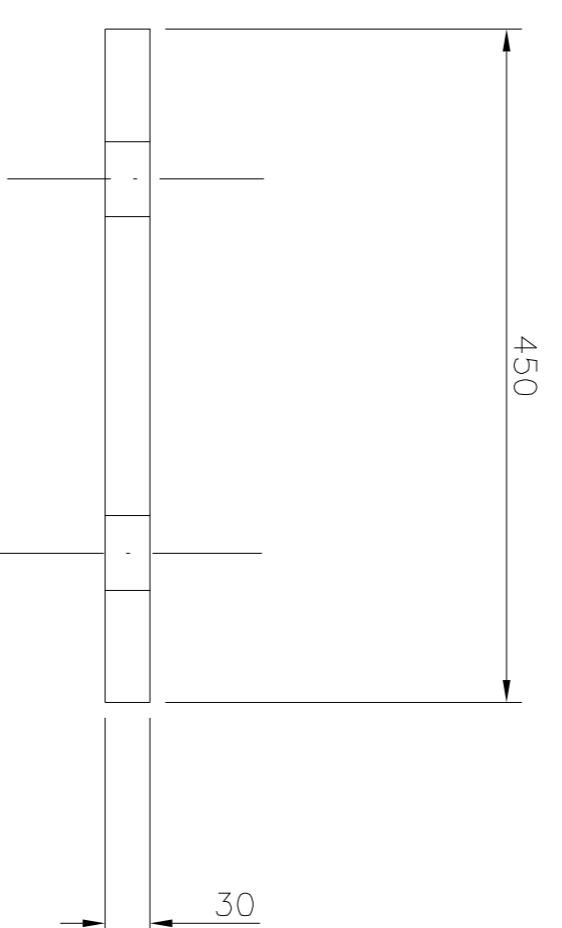

ITEM 2
BASE PLATE x 2 OFF
MASS 64kg EACH

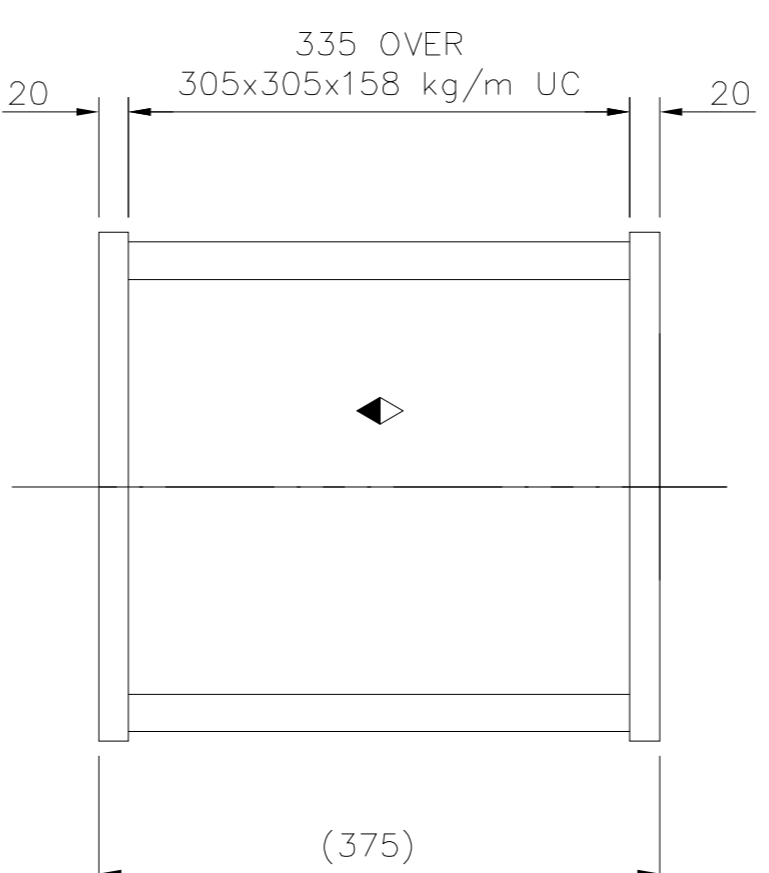

ITEM 3
STOOL x 2 OFF
MASS 87kg EACH

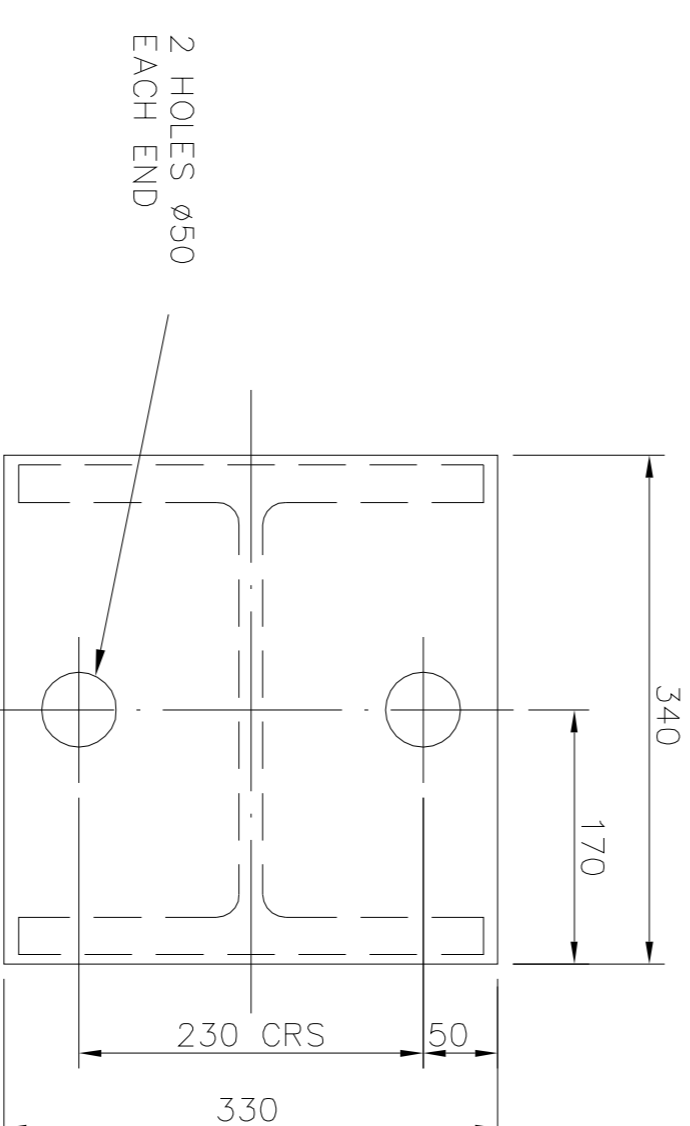

ITEM 4
PACKER x 7 OFF
MASS 31kg EACH

MANUFACTURING NOTES :-

- ALL WELDS TO BE 6mm CONT. FILLETS TO CONTRACT MANUFACTURING SPECIFICATION.
- REMOVE ALL BURRS & SHARP EDGES.
- PAINT TO MANUFACTURING SPECIFICATION.

DRAWN	CHECKED	APPROVED	DRAWN	CHECKED	APPROVED	DRAWN	CHECKED	APPROVED	DRAWN	CHECKED	APPROVED	DRAWN	CHECKED	APPROVED	DRAWN	CHECKED	APPROVED	DRAWN	CHECKED	APPROVED
DATE	DATE	DATE	DATE	DATE	DATE	DATE	DATE	DATE	DATE	DATE	DATE	DATE	DATE	DATE	DATE	DATE	DATE	DATE	DATE	DATE

UNLESS OTHERWISE SPECIFIED IDENTIFY THE ITEM WITH THE DRAWING NUMBER AND ISSUE LEVEL AT AND IN THE MANNER SHOWN FOR PAINTING AND FOR LUBRICATION SPECIFICATIONS SEE COMPONENTS LIST.

ISSUES RAISED GEN.UPDATE
AS BUILT

FIRST ISSUE

THIS PRINT AND ALL THE INFORMATION HEREON IS THE PROPERTY OF METSO MINERALS. BULK MATERIALS HANDLING FIRST AND MUST NOT BE MADE PUBLIC, COPIED OR USED IN ANY WAY DETRIMENTAL TO OUR INTEREST. IT IS LOANED SUBJECT TO RETURN ON DEMAND UNLESS FURNISHED UNDER CONTRACT PROVISIONS.

RANGE 0-500
501-1000
1001-2000
ABOVE 2000

MACH 0.25
FAB 3
CAST 2

TOLERANCES UNLESS OTHERWISE STATED (PLUS OR MINUS)

DO NOT SCALE
IF IN DOUBT - ASK

metso
minerals

SOUTH AFRICAN PORT OPERATIONS
IRON ORE TERMINAL - SALDANHA
STACKER RECLAIMER CONTRACT HQH375
SANCTION No. SB01 D1

metso minerals (UK) Ltd
BULK MATERIALS HANDLING BRISTOL
PO BOX 821 ASHTON VALE RD
BRISTOL BS399 5ZB ENGLAND

TITLE
SALDANHA BAY STACKER RECLAIMER
ASSY & DETAILS OF MAINTENANCE
EQUIPMENT

DRAMA TO BS 8888
WELDS SYMBOLS TO BS EN 22553
WELD TEXTURE TO BS EN 22553
MATERIAL & CONDITION BEFORE MANUFACTURE

THIRD ANGLE
DRAWING

MATERIAL, STEEL

SPEC SABS 14.31

GRADE 300WA

MASS 1475kg

ORIGINAL SCALE 1:5

SIZE A1

DRAWING NUMBER 700399

SHEET 3 OF 3
ISSUE B

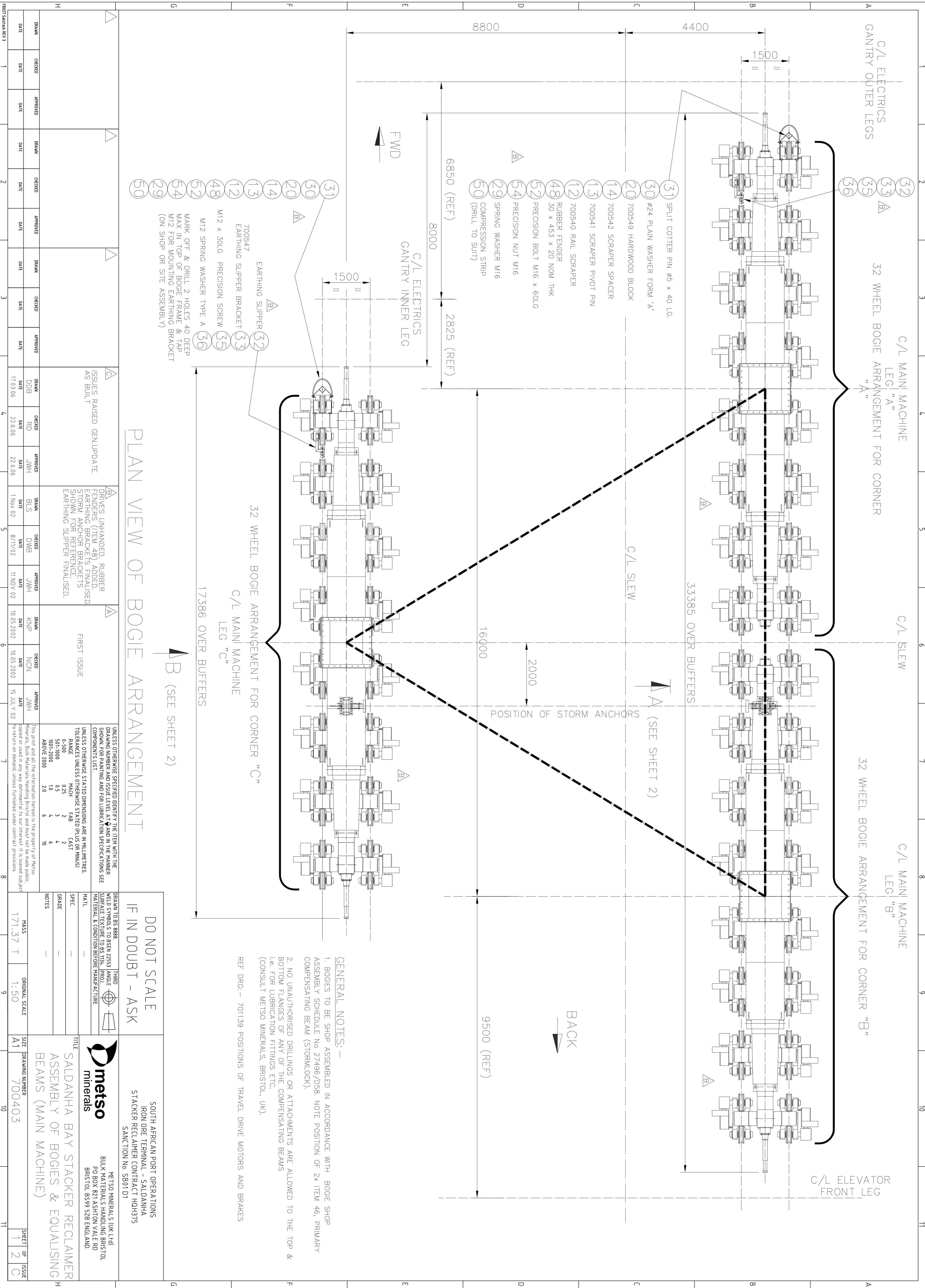

- 32) SPLIT COTTER PIN $\phi 5 \times 40$ LG.
- 30) $\phi 24$ PLAIN WASHER FORM 'A'
- 20) 700549 HARDWOOD BLOCK
- 14) 700542 SCRAPER SPACER
- 13) 700541 SCRAPER PIVOT PIN
- 12) 700540 RAIL SCRAPER
- 48) RUBBER FENDER
30 x 453 x 20 NOM THK
- 52) PRECISION BOLT M16 x 60LG
- 54) PRECISION NUT M16
- 29) SPRING WASHER M16
- 50) COMPRESSION STRIP
(DRILL TO SUIT)

- 31) EARTHING SLIPPER 32
- 33) EARTHING SLIPPER BRACKET
- 35) M12 x 30LG PRECISION SCREW
- 48) M12 SPRING WASHER TYPE A
- 52) MARK OFF & DRILL 2 HOLES 40 DEEP
MAX IN TOP OF BOGIE FRAME & TAP
M12 FOR MOUNTING EARTHING BRACKET
(ON SHOP OR SITE ASSEMBLY)
- 54)
- 56)

- 32) EARTHING SLIPPER
- 33) EARTHING SLIPPER BRACKET
- 35) M12 x 30LG PRECISION SCREW
- 48) M12 SPRING WASHER TYPE A
- 52) MARK OFF & DRILL 2 HOLES 40 DEEP
MAX IN TOP OF BOGIE FRAME & TAP
M12 FOR MOUNTING EARTHING BRACKET
(ON SHOP OR SITE ASSEMBLY)
- 54)
- 56)

DRAWN	CHECKED	APPROVED	DRAWN	CHECKED	APPROVED	DRAWN	CHECKED	APPROVED	DRAWN	CHECKED	APPROVED	DRAWN	CHECKED	APPROVED	DRAWN	CHECKED	APPROVED
DATE	DATE	DATE	DATE	DATE	DATE	DATE	DATE	DATE	DATE	DATE	DATE	DATE	DATE	DATE	DATE	DATE	DATE

PLAN VIEW OF BOGIE ARRANGEMENT

ISSUES RAISED GEN.UPDATE.
AS BUILT

DRIVES UNHANDLED. RUBBER FENDERS (ITEM 48), ADDED. EARTHING BRACKETS FINALISED. STORM ANCHOR BRACKETS SHOWN FOR REFERENCE. EARTHING SLIPPER FINALISED.

FIRST ISSUE

UNLESS OTHERWISE SPECIFIED IDENTIFY THE ITEM WITH THE DRAWING NUMBER AND ISSUE LEVEL AT \blacktriangledown AND IN THE MANNER SHOWN FOR PAINTING AND FOR LUBRICATION SPECIFICATIONS SEE COMPONENTS LIST.

TOLERANCES UNLESS OTHERWISE STATED (PLUS OR MINUS)

RANGE	MACH	FAB	CAST
0-500	0.25	2	2
501-1000	0.5	3	4
1001-2000	1.0	4	6
ABOVE 2000	2.0	6	10

THIS PRINT AND ALL THE INFORMATION HEREON IS THE PROPERTY OF METSO MINERALS. BULK MATERIALS HANDLING FIRST AND MUST NOT BE MADE PUBLIC, COPIED OR USED IN ANY WAY DETRIMENTAL TO OUR INTEREST. IT IS LOANED SUBJECT TO RETURN ON DEMAND, UNLESS FURNISHED UNDER CONTRACT PROVISIONS.

DO NOT SCALE
IF IN DOUBT - ASK

metso minerals

SOUTH AFRICAN PORT OPERATIONS
IRON ORE TERMINAL - SALDANHA
STACKER RECLAIMER CONTRACT HQH375
SANCTION No. SB01 D1

METSO MINERALS (UK) LTD
BULK MATERIALS HANDLING BRISTOL
PO BOX 821 ASHTON VALE RD
BRISTOL BS99 5ZB ENGLAND

TITLE
SALDANHA BAY STACKER RECLAIMER
ASSEMBLY OF BOGIES & EQUALISING
BEAMS (MAIN MACHINE)

MASS 171.37 T ORIGINAL SCALE 1:50 SIZE DRAWING NUMBER A1 700403 SHEET OF 1 2 OF 2 ISSUE C

GENERAL NOTES:

- BOGIES TO BE SHOP ASSEMBLED IN ACCORDANCE WITH BOGIE SHOP ASSEMBLY SCHEDULE No 27496/D58. NOTE POSITION OF 2x ITEM 46, PRIMARY COMPENSATING BEAM (STORMLOCK).
- NO UNAUTHORISED DRILLINGS OR ATTACHMENTS ARE ALLOWED TO THE TOP & BOTTOM FLANGES OF ANY OF THE COMPENSATING BEAMS
i.e. FOR LUBRICATION FITTINGS ETC.
(CONSULT METSO MINERALS, BRISTOL, UK).

REF DRG: - 701139 POSITIONS OF TRAVEL DRIVE MOTORS AND BRAKES

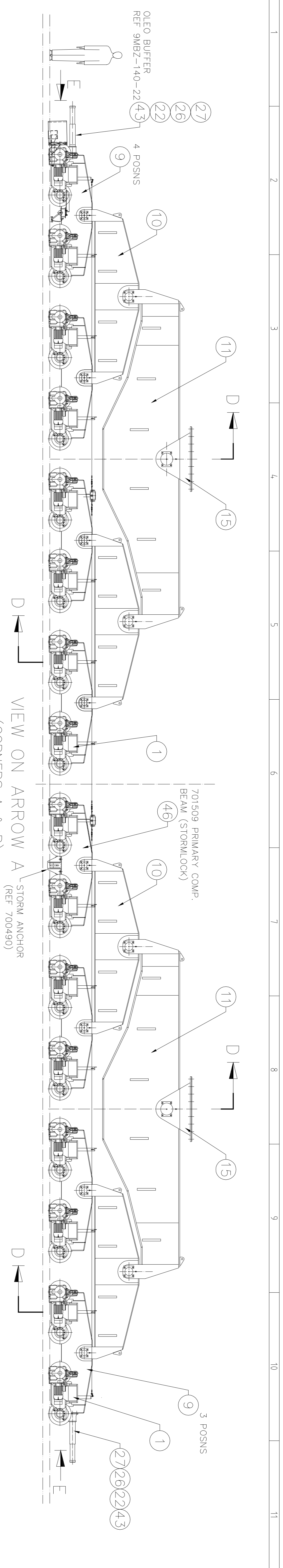

VIEW ON ARROW A
(CORNERS A & B)
STORM ANCHOR
(REF 700490)

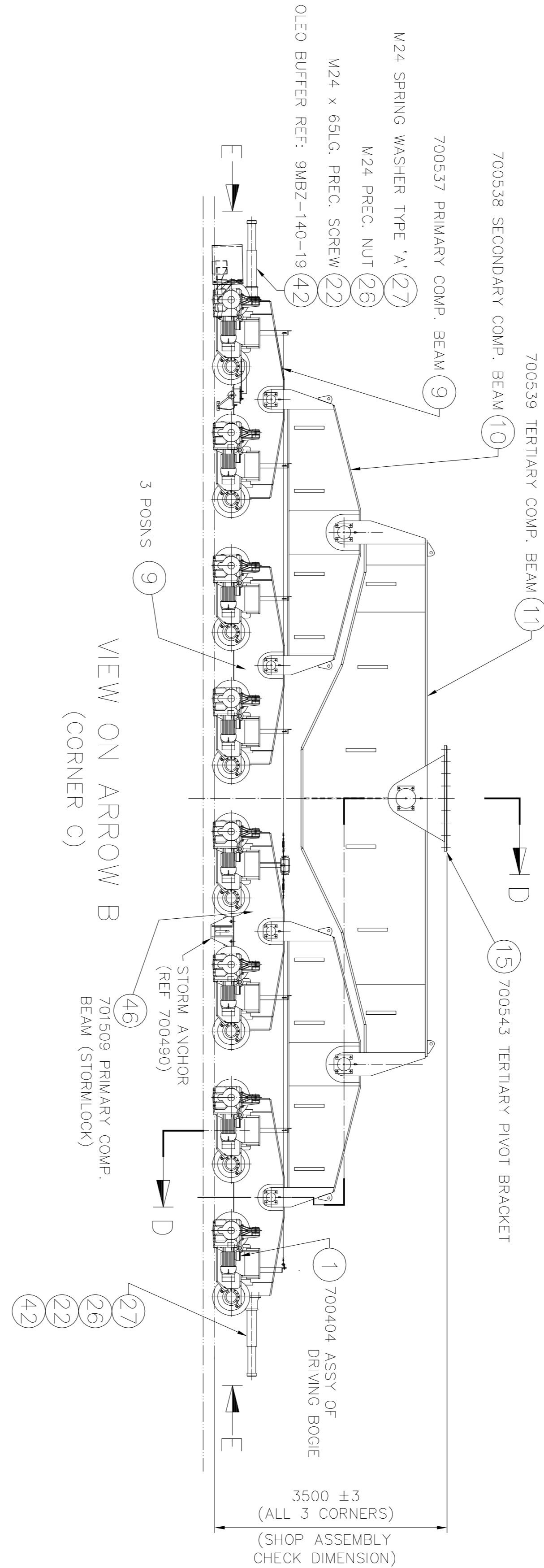

VIEW ON ARROW B
(CORNER C)

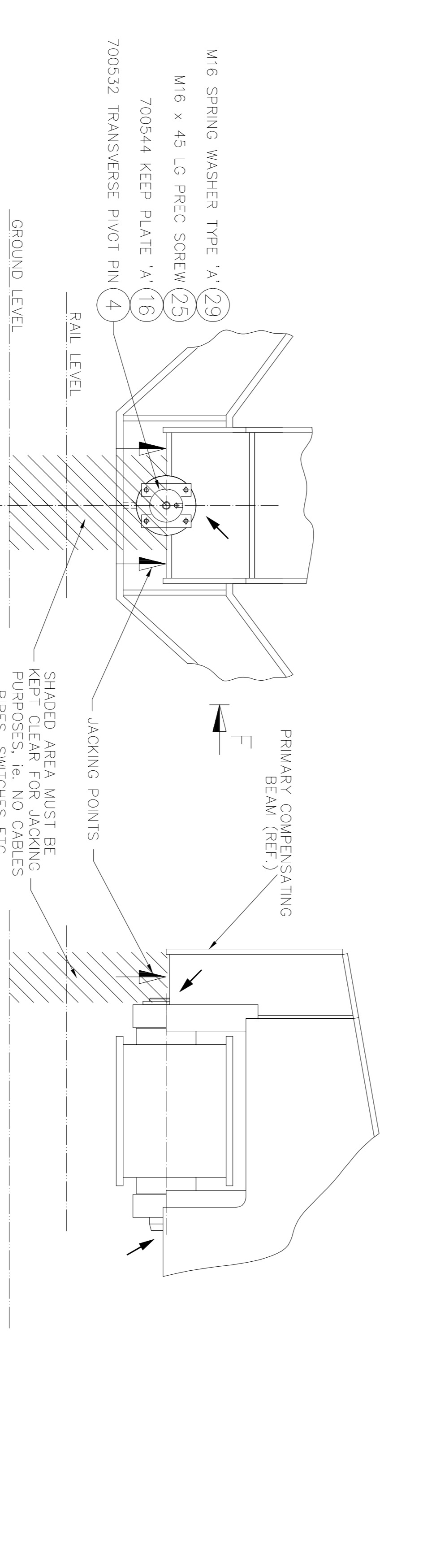

PART VIEW ON ARROW E
(TYP)
(SCALE 1:10)

VIEW ON ARROW F
(SCALE 1:10)

SECTION D-D
SHOWING CONNECTIONS THROUGH BOGIE CORNER GROUP
(TYPICAL FOR ALL 3 (32 WHEEL) BOGIE SETS)
(SCALE 1:15)

NOTE :-
AT POSITIONS SHOWN THUS →
INSTALL LUBRICATION FITTINGS (DURING
BUILD) SUITABLE FOR FUTURE CONNECTION
TO GROUPED SYSTEMS. BLANK OFF EXPOSED
ENDS AS REQUIRED. REFER ALSO TO
27496/D42. SPECIFICATION FOR GREASE
LUBRICATION.

- 27 M24 SPRING WASHER TYPE 'A'
- 23 M24 x 55 LG PREC SCREW
- 18 700546 KEEP PLATE 'C'
- 7 700535 TERTIARY PIVOT PIN
- 27 M24 SPRING WASHER TYPE 'A'
- 23 M24 x 55 LG. PREC. SCREW
- 18 700546 KEEP PLATE 'C'
- 6 700534 SECONDARY PIVOT PIN
- 28 M20 SPRING WASHER TYPE 'A'
- 24 M20 x 50 LG PREC SCREW
- 17 700545 KEEP PLATE 'B'
- 5 700533 PRIMARY PIVOT PIN
- 8 700536 TRANSVERSE COMP. BEAM
- 3 700531 BOGIE PIVOT PIN
- 16 700544 KEEP PLATE 'A'
- 25 M16 x 45 LG. PREC. SCREW
- 29 M16 SPRING WASHER TYPE 'A'

ISSUES RAISED GENUPDATE:
AS BUILT

ITEMS 21 DELETED (96 OFF),
QTY OF ITEMS 26 & 27
ADJUSTED.
LUB FITTINGS NOTE ADDED.
STORM ANCHORS SHOWN FOR
REFERENCE.
SEE ALSO SHEET 1.

DATE	APPROVED	DATE	APPROVED	DATE	APPROVED	DATE	APPROVED	DATE	APPROVED	DATE	APPROVED	DATE	APPROVED	DATE	APPROVED	DATE	APPROVED	DATE	APPROVED	
18/03/06	DDB	22/6/06	RD	22/6/06	JWH	28/04/02	BLS	8/NOV/02	DWB	11/NOV/02	JWH	10/05/2002	KNP	10/05/2002	NCN	15/JUL/02	JWH			

DRAWN TO BS 8888	WELD SYMBOLS TO AS/ANSI 2.4	THIRD ANGLE
SURFACE TEXTURE TO BS 7178, PRO	PATENT & CONDITION BEFORE MANUFACTURE	
MATL -		
SPEC -		
GRADE -		
NOTES		
SEE SHEET 1	1:50 UOS	ORIGINAL SCALE
SIZE	DRAWING NUMBER	SIZE
	700403	A1

DO NOT SCALE IF IN DOUBT - ASK	
SOUTH AFRICAN PORT OPERATIONS IRON ORE TERMINAL - SALDANHA STACKER RECLAIMER CONTRACT HQ4375 SANCTION No. SB01 D1	METSO MINERALS (UK) LTD BULK MATERIALS HANDLING BRISTOL PO BOX 821 ASTTON VALE RD BRISTOL BS99 5ZB ENGLAND

TITLE	SALDANHA BAY STACKER RECLAIMER ASSEMBLY OF BOGIES & EQUALISING BEAMS (MAIN MACHINE)
MASS	700403
SHEET	2
OF	2
ISSUE	C

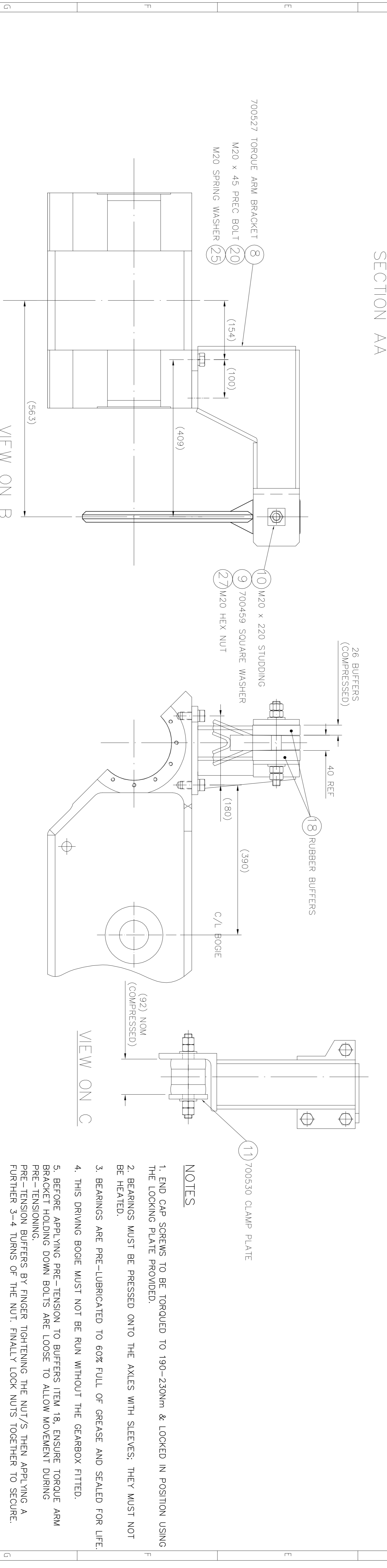
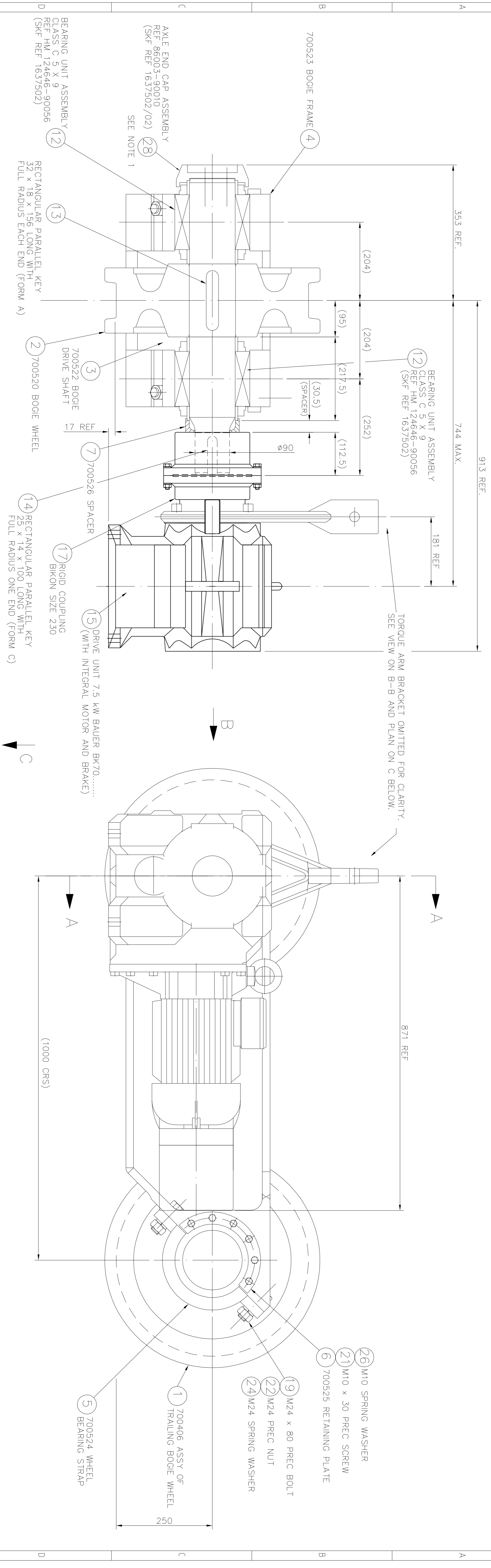

SHOWING TORQUE ARM BRACKET
(DRIVE UNIT OMITTED FOR CLARITY)

ISSUES RAISED GENUINE UPDATE
AS BUILT

FIRST ISSUE

DATE	APPROVED	DATE	APPROVED	DATE	APPROVED	DATE	APPROVED	DATE	APPROVED	DATE	APPROVED	DATE	APPROVED
19.04.06		22.6.06		10 JUL Y 02		17 JUL Y 02		17 JUL Y 02					

DO NOT SCALE
IF IN DOUBT - ASK

metso minerals

SOUTH AFRICAN PORT OPERATIONS
IRON ORE TERMINAL - SALDANHA
STACKER RECLAIMER CONTRACT HQH375
SANCTION No. SB01 D1

METSO MINERALS (UK) LTD
BULK MATERIALS HANDLING BRISTOL
PO BOX 821 ASHTON VALE RD
BRISTOL BS39 5ZB ENGLAND

TITLE: SALDANHA BAY STACKER RECLAIMER ASSEMBLY OF DRIVING BOGIE

MASS: 1361kg ORIGINAL SCALE: 1:5 SIZE: A1

SHEET OF 11 ISSUE B

- NOTES**
1. END CAP SCREWS TO BE TORQUED TO 190-230Nm & LOCKED IN POSITION USING THE LOCKING PLATE PROVIDED.
 2. BEARINGS MUST BE PRESSED ONTO THE AXLES WITH SLEEVES. THEY MUST NOT BE HEATED.
 3. BEARINGS ARE PRE-LUBRICATED TO 60% FULL OF GREASE AND SEALED FOR LIFE.
 4. THIS DRIVING BOGIE MUST NOT BE RUN WITHOUT THE GEARBOX FITTED.
 5. BEFORE APPLYING PRE-TENSION TO BUFFERS ITEM 18, ENSURE TORQUE ARM BRACKET HOLDING DOWN BOLTS ARE LOOSE TO ALLOW MOVEMENT DURING PRE-TENSIONING.
- PRE-TENSION BOGIES BY FINGER TIGHTENING THE NUT/S THEN APPLYING A FURTHER 3-4 TURNS OF THE NUT. FINALLY LOCK NUTS TOGETHER TO SECURE.

UNLESS OTHERWISE SPECIFIED IDENTIFY THE ITEM WITH THE DRAWING NUMBER AND ISSUE LEVEL AT THE END IN THE MANNER SHOWN FOR PAINTING AND FOR LUBRICATION SPECIFICATIONS SEE COMPONENTS LIST.

TOLERANCES UNLESS OTHERWISE STATED (PLUS OR MINUS)

TOLERANCE RANGE	MACH	FAB	CAST
0-500	2	2	2
501-1000	0.25	3	4
1001-2000	0.5	4	6
ABOVE 2000	2.0	6	10

This print and all the information herein is the property of Metso Minerals. Bulk Materials Handling Bristol and must not be made public, copied or used in any way detrimental to our interest. It is loaned subject to return on demand unless furnished under contract provisions.

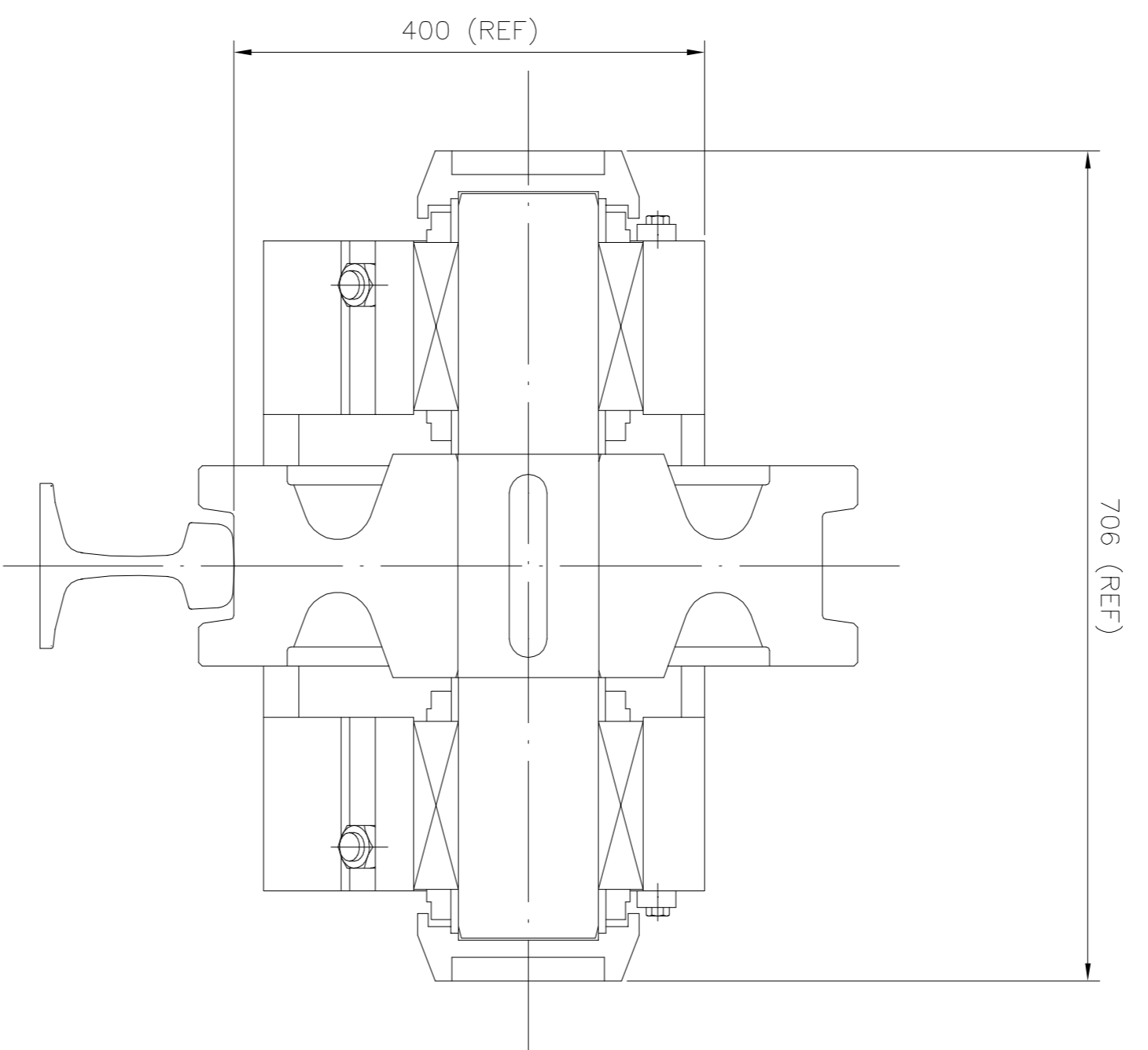

SECTION AA

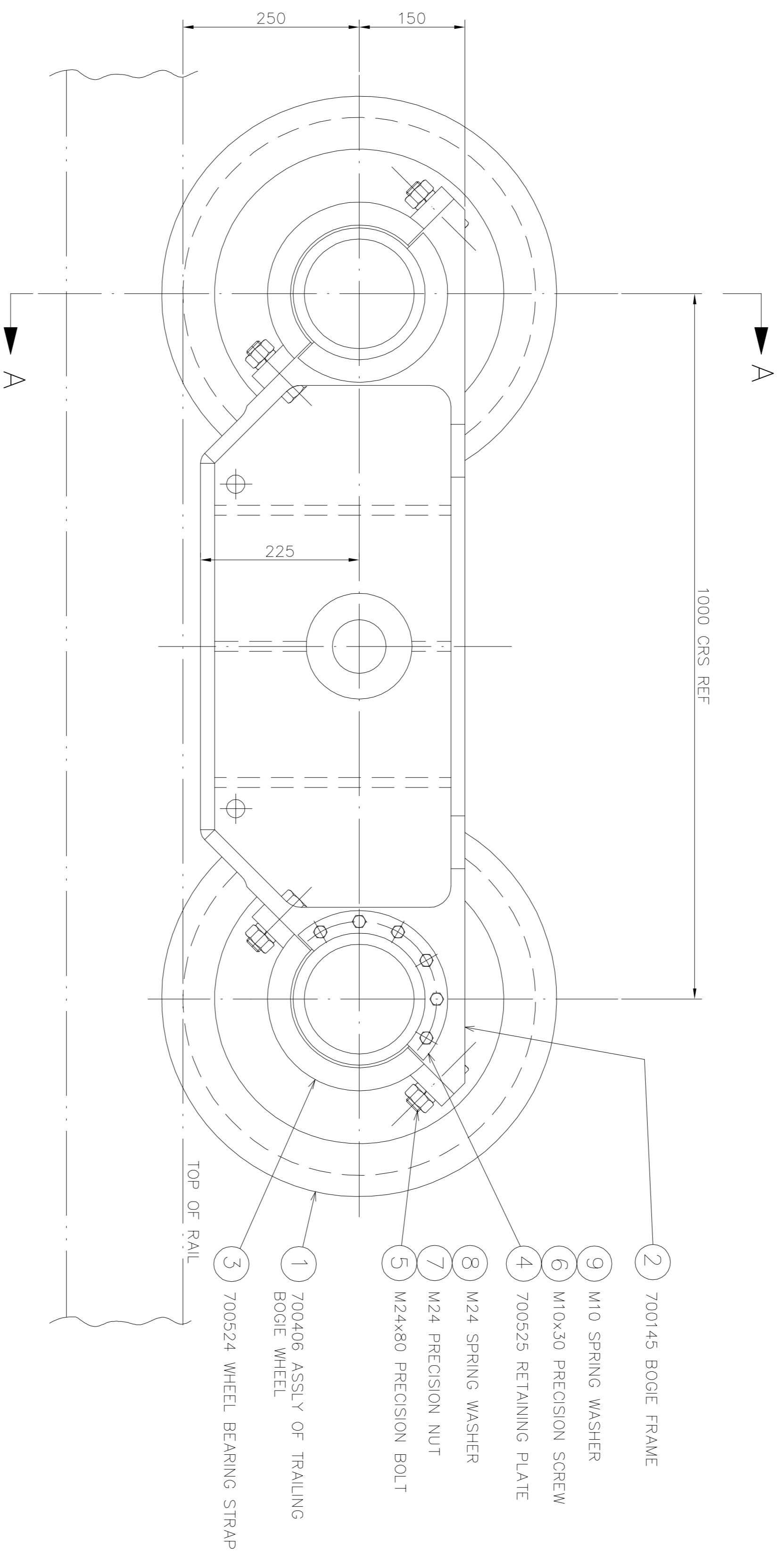

DATE	CHECKED	APPROVED	DATE	CHECKED	APPROVED	DATE	CHECKED	APPROVED	DATE	CHECKED	APPROVED	DATE	CHECKED	APPROVED	DATE	CHECKED	APPROVED
1			1			1			1			1			1		
2			2			2			2			2			2		
3			3			3			3			3			3		
4			4			4			4			4			4		
5			5			5			5			5			5		
6			6			6			6			6			6		
7			7			7			7			7			7		
8			8			8			8			8			8		

<p>UNLESS OTHERWISE SPECIFIED IDENTIFY THE ITEM WITH THE DRAWING NUMBER AND ISSUE LEVEL AT THE END IN THE MANNER SHOWN FOR PAINTING AND FOR LUBRICATION SPECIFICATIONS SEE COMPONENTS LIST.</p> <p>TOLERANCES UNLESS OTHERWISE STATED (PLUS OR MINUS)</p> <table border="1"> <tr> <th>RANGE</th> <th>MACH</th> <th>FAB</th> <th>CAST</th> </tr> <tr> <td>0-500</td> <td>0.25</td> <td>2</td> <td>2</td> </tr> <tr> <td>501-1000</td> <td>0.5</td> <td>3</td> <td>4</td> </tr> <tr> <td>1001-2000</td> <td>1.0</td> <td>4</td> <td>6</td> </tr> <tr> <td>ABOVE 2000</td> <td>2.0</td> <td>6</td> <td>10</td> </tr> </table> <p>This print and all the information herein is the property of Metso Minerals. Bulk Materials Handling Bristol and must not be made public, copied or used in any way detrimental to our interest. It is loaned subject to return on demand unless furnished under contract provisions.</p>		RANGE	MACH	FAB	CAST	0-500	0.25	2	2	501-1000	0.5	3	4	1001-2000	1.0	4	6	ABOVE 2000	2.0	6	10	<p>UNLESS OTHERWISE SPECIFIED IDENTIFY THE ITEM WITH THE DRAWING NUMBER AND ISSUE LEVEL AT THE END IN THE MANNER SHOWN FOR PAINTING AND FOR LUBRICATION SPECIFICATIONS SEE COMPONENTS LIST.</p> <p>TOLERANCES UNLESS OTHERWISE STATED (PLUS OR MINUS)</p> <table border="1"> <tr> <th>RANGE</th> <th>MACH</th> <th>FAB</th> <th>CAST</th> </tr> <tr> <td>0-500</td> <td>0.25</td> <td>2</td> <td>2</td> </tr> <tr> <td>501-1000</td> <td>0.5</td> <td>3</td> <td>4</td> </tr> <tr> <td>1001-2000</td> <td>1.0</td> <td>4</td> <td>6</td> </tr> <tr> <td>ABOVE 2000</td> <td>2.0</td> <td>6</td> <td>10</td> </tr> </table> <p>This print and all the information herein is the property of Metso Minerals. Bulk Materials Handling Bristol and must not be made public, copied or used in any way detrimental to our interest. It is loaned subject to return on demand unless furnished under contract provisions.</p>		RANGE	MACH	FAB	CAST	0-500	0.25	2	2	501-1000	0.5	3	4	1001-2000	1.0	4	6	ABOVE 2000	2.0	6	10
RANGE	MACH	FAB	CAST																																								
0-500	0.25	2	2																																								
501-1000	0.5	3	4																																								
1001-2000	1.0	4	6																																								
ABOVE 2000	2.0	6	10																																								
RANGE	MACH	FAB	CAST																																								
0-500	0.25	2	2																																								
501-1000	0.5	3	4																																								
1001-2000	1.0	4	6																																								
ABOVE 2000	2.0	6	10																																								
<p>ISSUES RAISED GEN.UPDATE AS BUILT</p> <p>BRN DDB DATE 22.03.06</p> <p>CHKD RD DATE 22.6.06</p> <p>APPRD JWH DATE 22.6.06</p>	<p>FIRST ISSUE</p> <p>BRN USB DATE 31/05/2002</p> <p>CHKD NCN DATE 31/05/2002</p> <p>APPRD JWH DATE 11/7/02</p>	<p>DO NOT SCALE</p> <p>IF IN DOUBT - ASK</p>	<p>THIRD</p> <p>WELD SYMBOLS TO BS EN 22533</p> <p>ANGLE</p> <p>WHEEL TEXTURE TO BS EN 1230</p> <p>WHEEL MATERIAL & CONDITION BEFORE MANUFACTURE</p>	<p>1048 kg</p> <p>ORIGINAL SCALE 1:5</p> <p>SIZE DRAWING NUMBER A1 700405</p>																																							

metso
 minerals

SOUTH AFRICAN PORT OPERATIONS
 IRON ORE TERMINAL - SALDANHA
 STACKER RECLAIMER CONTRACT HQH375
 SANCTION No. SB01 D1

METSO MINERALS (UK) LTD
 BULK MATERIALS HANDLING BRISTOL
 PO BOX 821 ASHTON VALE RD
 BRISTOL BS99 5ZB ENGLAND

ASSEMBLY OF TRAILING BOGIE

MASS 1048 kg
 ORIGINAL SCALE 1:5
 SIZE DRAWING NUMBER A1 700405
 SHEET OF 1
 ISSUE B

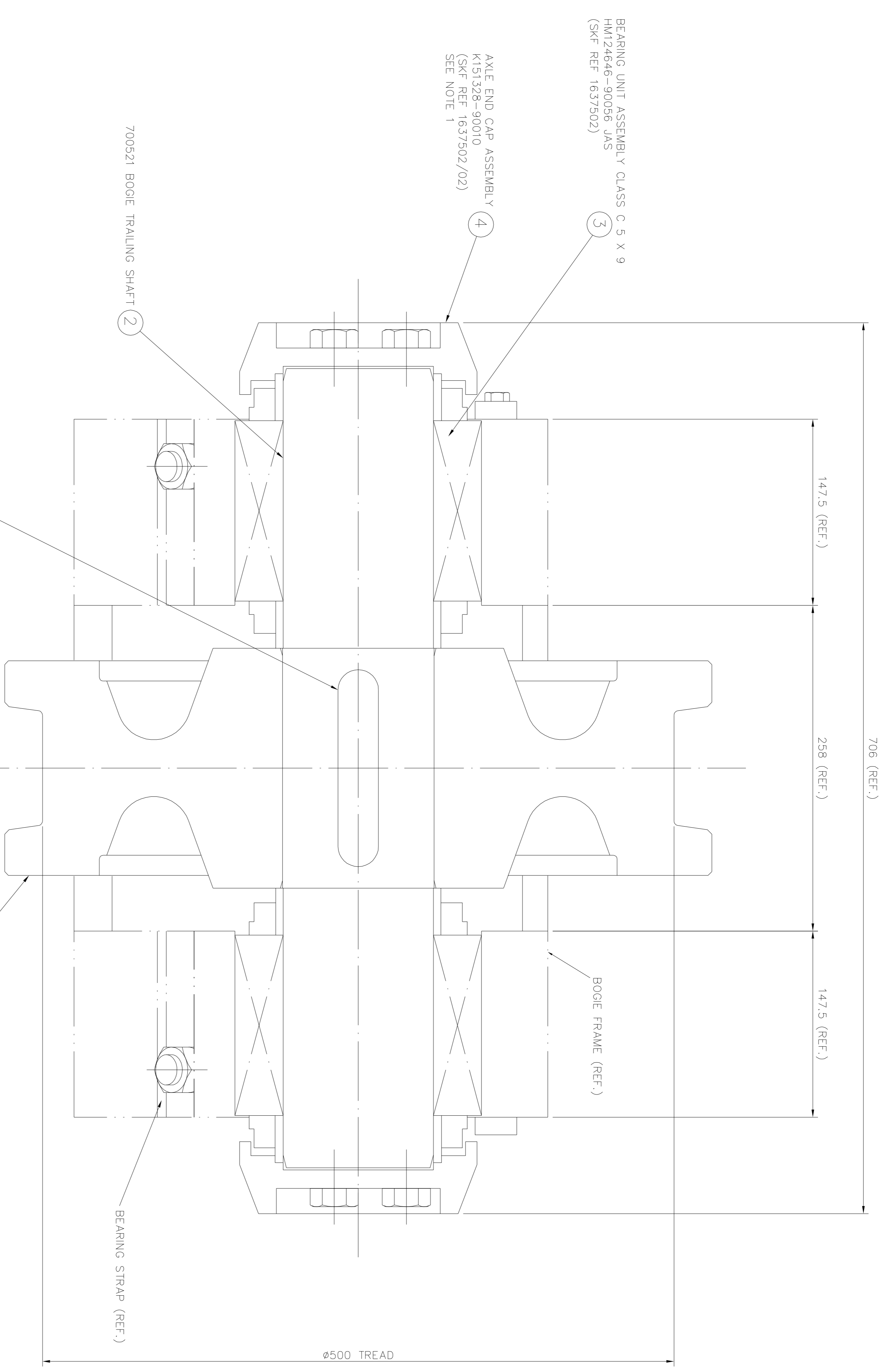

- GENERAL NOTES
1. END CAP SCREWS TO BE TORQUED TO 190-230Nm & LOCKED IN POSITION USING THE LOCKING PLATE PROVIDED
 2. WHEEL MUST BE MOUNTED CENTRALLY ON SHAFT MAX DIA
 3. BEARINGS MUST BE PRESSED ONTO THE SHAFT WITH SLEEVES THEY MUST NOT BE HEATED
 4. BEARINGS ARE PRE-LUBRICATED TO 60% FULL OF GREASE AND SEALED FOR LIFE

DATE	CHECKED	APPROVED	DATE	CHECKED	APPROVED	DATE	CHECKED	APPROVED	DATE	CHECKED	APPROVED	DATE	CHECKED	APPROVED
19/04/06	DDB	RD	22/6/06	JWH	15/04/2002	PLT	JWH	15/04/2002	MAY 2002					

ISSUES RAISED GEN UPDATE AS BUILT

FIRST ISSUE

UNLESS OTHERWISE SPECIFIED IDENTIFY THE ITEM WITH THE DRAWING NUMBER AND ISSUE LEVEL AT THE END IN THE MANNER SHOWN FOR PAINTING AND FOR LUBRICATION SPECIFICATIONS SEE COMPONENTS LIST

TOLERANCES UNLESS OTHERWISE STATED (PLUS OR MINUS)

RANGE	MACH	FAB	CAST
0-500	2	2	4
501-1000	0.5	3	4
1001-2000	1.0	4	6
ABOVE 2000	2.0	6	10

This print and all the information herein is the property of Metso Minerals. Bulk Materials Handling Bristol and must not be made public, copied or used in any way detrimental to our interest. It is loaned subject to return on demand unless furnished under contract provisions.

DO NOT SCALE
IF IN DOUBT - ASK

THIRD ANGLE

WELD SYMBOLS TO BS EN 22533 ANGLE
WELD TEXTURE TO BS 1133 LARG
WELD TOOTH TO BS 1133 LARG
MATERIAL & CONDITION BEFORE MANUFACTURE

MATERIAL

SPEC

GRADE

MASS 322 kg ORIGINAL SCALE 1:2 SIZE DRAWING NUMBER A1 700406

TITLE

ASSY. OF TRAILING BOGIE WHEEL

SOUTH AFRICAN PORT OPERATIONS
IRON ORE TERMINAL - SALDANHA
STACKER RECLAIMER CONTRACT HQH375
SANCTION No. SB01 D1

METSO MINERALS (UK) LTD
BULK MATERIALS HANDLING BRISTOL
PO BOX 821 ASHTON VALE RD
BRISTOL BS99 5ZB ENGLAND

metso minerals

SHEET OF 1 ISSUE 1 B

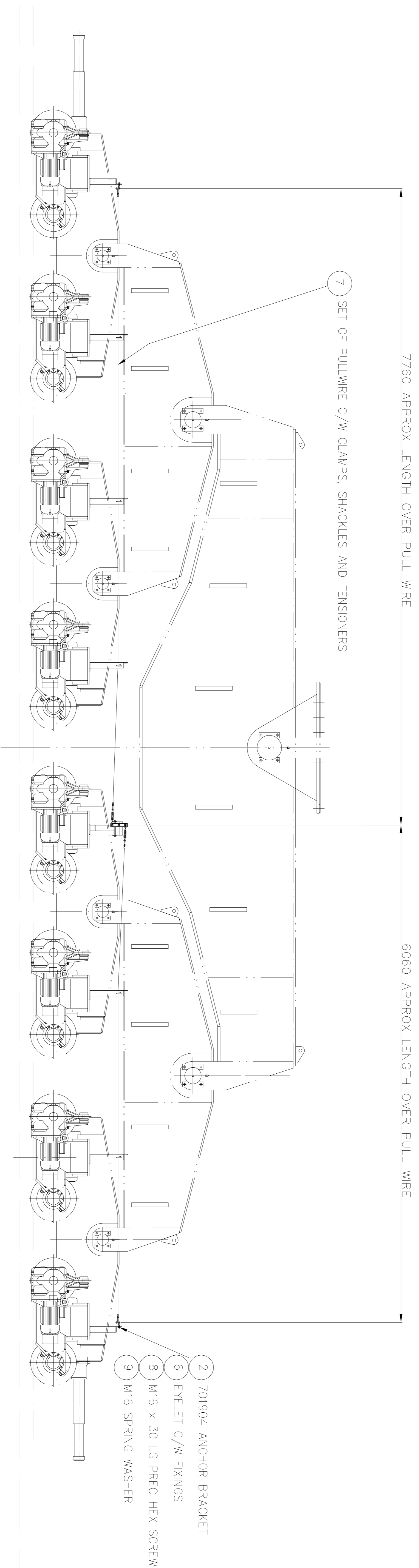
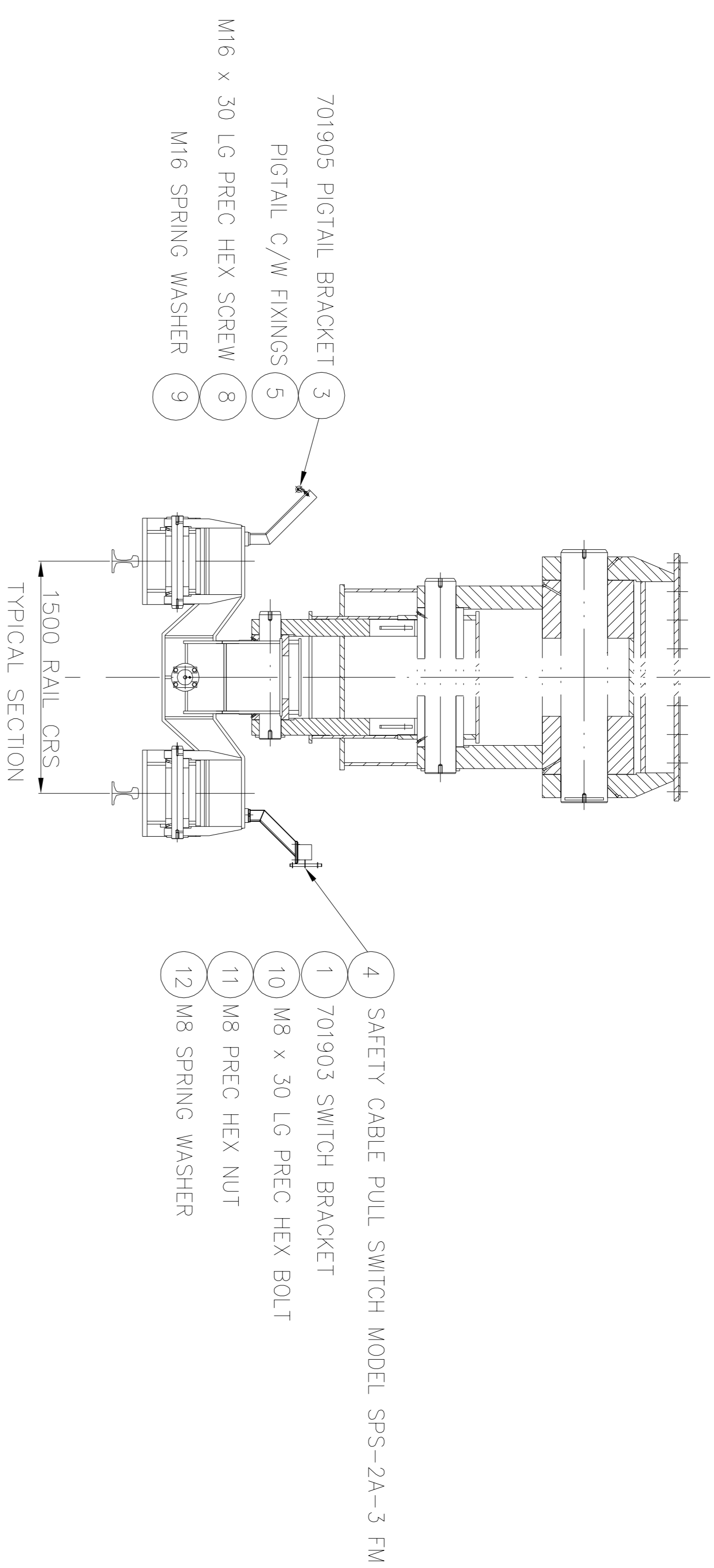

TYPICAL VIEW ON CORNER
ALL CORNERS SIMILAR
BOTH SIDES

ISSUES RAISED GEN UPDATE
AS BUILT

FIRST ISSUE

UNLESS OTHERWISE SPECIFIED IDENTIFY THE ITEM WITH THE DRAWING NUMBER AND ISSUE LEVEL AT AND IN THE MANNER SHOWN FOR PAINTING AND FOR LUBRICATION SPECIFICATIONS SEE COMPONENTS LIST.
UNLESS OTHERWISE STATED DIMENSIONS ARE IN MILLIMETRES
TOLERANCES UNLESS OTHERWISE STATED (PLUS OR MINUS)
RANGE MACH FAB CAST
0-500 0.5 3 4
501-1000 0.5 3 4
1001-2000 1.0 4 6
ABOVE 2000 2.0 6 10

DO NOT SCALE
IF IN DOUBT - ASK

SOUTH AFRICAN PORT OPERATIONS
IRON ORE TERMINAL - SALDANHA
STACKER RECLAIMER CONTRACT HQH375
SANCTION No. SB01 D1

metso
minerals

METSO MINERALS (UK LTD)
BULK MATERIALS HANDLING BRISTOL
PO BOX 821 ASHTON VALE RD
BRISTOL BS99 5ZB ENGLAND

DATE	DATE	DATE	DATE	DATE	DATE	DATE	DATE	DATE	DATE	DATE	DATE	DATE	DATE	DATE	DATE	DATE	DATE
1	2	3	4	5	6	7	8	9	10	11							
DRAWN	CHECKED	APPROVED	DRAWN	CHECKED	APPROVED	DRAWN	CHECKED	APPROVED	DRAWN	CHECKED	APPROVED	DATE	DATE	DATE	DATE	DATE	DATE
												19.04.06	22.6.06	22.6.06	01.11.2002	20.11.02	20.11.02
												DDB	RD	JWH	AJE	DJS	DJS

MASS	247	kg	ORIGINAL SCALE	1:25	SIZE	A1	DRAWING NUMBER	700407	SHEET	1	OF	1	ISSUE	B
<p>ASSEMBLY OF BOGIE TRIPWIRES</p>														

FR0734164 REV 3

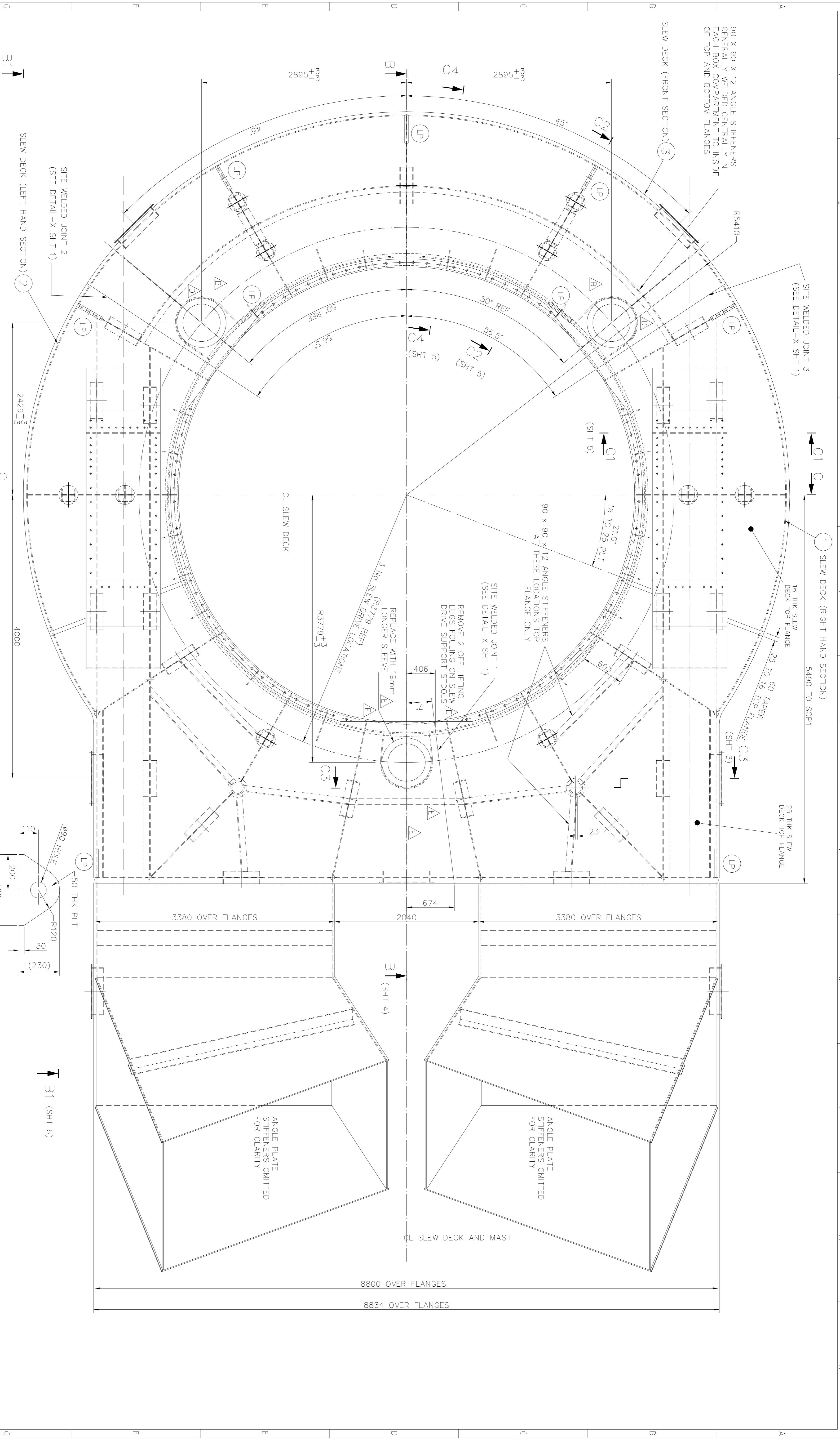

PART VIEW ON ARROW A (SHT 1)
SHOWING THE SLEW DECK & LOWER PARTS OF THE MAST
SCALE 1:25

AT 21 POSITIONS MARKED (LP)
DETAIL-B3

DO NOT SCALE
IF IN DOUBT - ASK

metso minerals

SOUTH AFRICAN PORT OPERATIONS
IRON ORE TERMINAL - SALDANHA
STACKER RECLAIMER CONTRACT HQH375
SANCTION No. SB01D1

METSO MINERALS (UK) Ltd
BULK MATERIALS HANDLING BRISTOL
PO BOX 821 ASHTON VALE RD
BRISTOL BS99 5ZB ENGLAND

ASSEMBLY & DETAILS OF
SLEW DECK & MAST STRUCTURE

<p>ISSUES RAISED GEN.UPDATE CUT AWAY RISA & ADD NEW WELDED CAP OFF LIFTING LUGS REMOVE 2 OFF LIFTING LUGS FOUling ON SLEW DRIVE STOOL REPLACE STOOL SUPPORT ONTO SLEW DECK BOLTS WITH M30x90 AS BUILT</p>		<p>GENERALLY MODIFIED TO AS BUILT STANDARD. HOLE SIZE PICTORIALY CORRECTED AT SLEW DRIVE. (NO CHANGES ON THIS SHEET)</p>		<p>ADDITIONAL INTERFACE INFO ADDED. SEE SHTS. 14-17.</p>		<p>STIFFENERS AROUND SLEW DRIVE POSITIONS REVISED SEE ALSO SHTS 1, & 3 TO 13</p>		<p>ISSUED FOR MANUFACTURE</p>		<p>UNLESS OTHERWISE SPECIFIED IDENTIFY THE ITEM WITH THE DRAWING NUMBER AND ISSUE LEVEL AT AND IN THE MANNER SHOWN FOR PAINTING AND FOR LUBRICATION SPECIFICATIONS SEE COMPONENTS LIST.</p> <p>UNLESS OTHERWISE STATED DIMENSIONS ARE IN MILLIMETRES TOLERANCES UNLESS OTHERWISE STATED PLUS OR MINUS</p> <p>RANGE MACH FAB CAST</p> <p>0-500 05 2 2 4</p> <p>501-1000 05 3 3 4</p> <p>1001-2000 10 4 4 6</p> <p>ABOVE 2000 20 6 6 10</p>		<p>THIS PRINT AND ALL THE INFORMATION HEREON IS THE PROPERTY OF METSO MINERALS. BULK MATERIALS HANDLING BRISTOL AND MUST NOT BE MADE PUBLIC, COPIED OR USED IN ANY WAY DETRIMENTAL TO OUR INTEREST. IT IS LOANED SUBJECT TO RETURN ON DEMAND UNLESS OTHERWISE STATED UNDER CONTRACT PROVISIONS.</p>											
DRAWN	CHECKED	DRAWN	CHECKED	DRAWN	CHECKED	DRAWN	CHECKED	DRAWN	CHECKED	DRAWN	CHECKED	DATE	DATE	DATE	DATE	DATE	DATE	DATE	DATE	DATE	DATE	DATE	
DDB	RD	JWH	APPROVED	DWB	CF	DWB	CF	GBL	JWH	FAB	JWH	USB	NCN	JWH	THIRD	WELD SYMBOLS TO BS EN 22553	ANGLE	WELD SYMBOLS TO BS EN 22553	WELD SYMBOLS TO BS EN 22553	WELD SYMBOLS TO BS EN 22553	WELD SYMBOLS TO BS EN 22553	WELD SYMBOLS TO BS EN 22553	WELD SYMBOLS TO BS EN 22553
16.02.06	22.6.06	22.6.06	22.6.06	DEC 04	JAN 05	JAN 05	JAN 05	8/10/02	18/10/02	21/10/02	15.08.02	15.08.02	16.08.02	16.08.02	15.06.02	29.06.02	15.7.02	15.7.02	15.7.02	15.7.02	15.7.02	15.7.02	15.7.02
<p>DATE</p>		<p>DATE</p>		<p>DATE</p>		<p>DATE</p>		<p>DATE</p>		<p>DATE</p>		<p>DATE</p>		<p>DATE</p>		<p>DATE</p>		<p>DATE</p>		<p>DATE</p>		<p>DATE</p>	
<p>APPROVED</p>		<p>APPROVED</p>		<p>APPROVED</p>		<p>APPROVED</p>		<p>APPROVED</p>		<p>APPROVED</p>		<p>APPROVED</p>		<p>APPROVED</p>		<p>APPROVED</p>		<p>APPROVED</p>		<p>APPROVED</p>		<p>APPROVED</p>	
<p>DATE</p>		<p>DATE</p>		<p>DATE</p>		<p>DATE</p>		<p>DATE</p>		<p>DATE</p>		<p>DATE</p>		<p>DATE</p>		<p>DATE</p>		<p>DATE</p>		<p>DATE</p>		<p>DATE</p>	
<p>DATE</p>		<p>DATE</p>		<p>DATE</p>		<p>DATE</p>		<p>DATE</p>		<p>DATE</p>		<p>DATE</p>		<p>DATE</p>		<p>DATE</p>		<p>DATE</p>		<p>DATE</p>		<p>DATE</p>	

MASS	ORIGINAL SCALE	SIZE	DRAWING NUMBER	SHEET	OF	ISSUE
SEE SHT 1	1:25	A1	700418	2	17	E

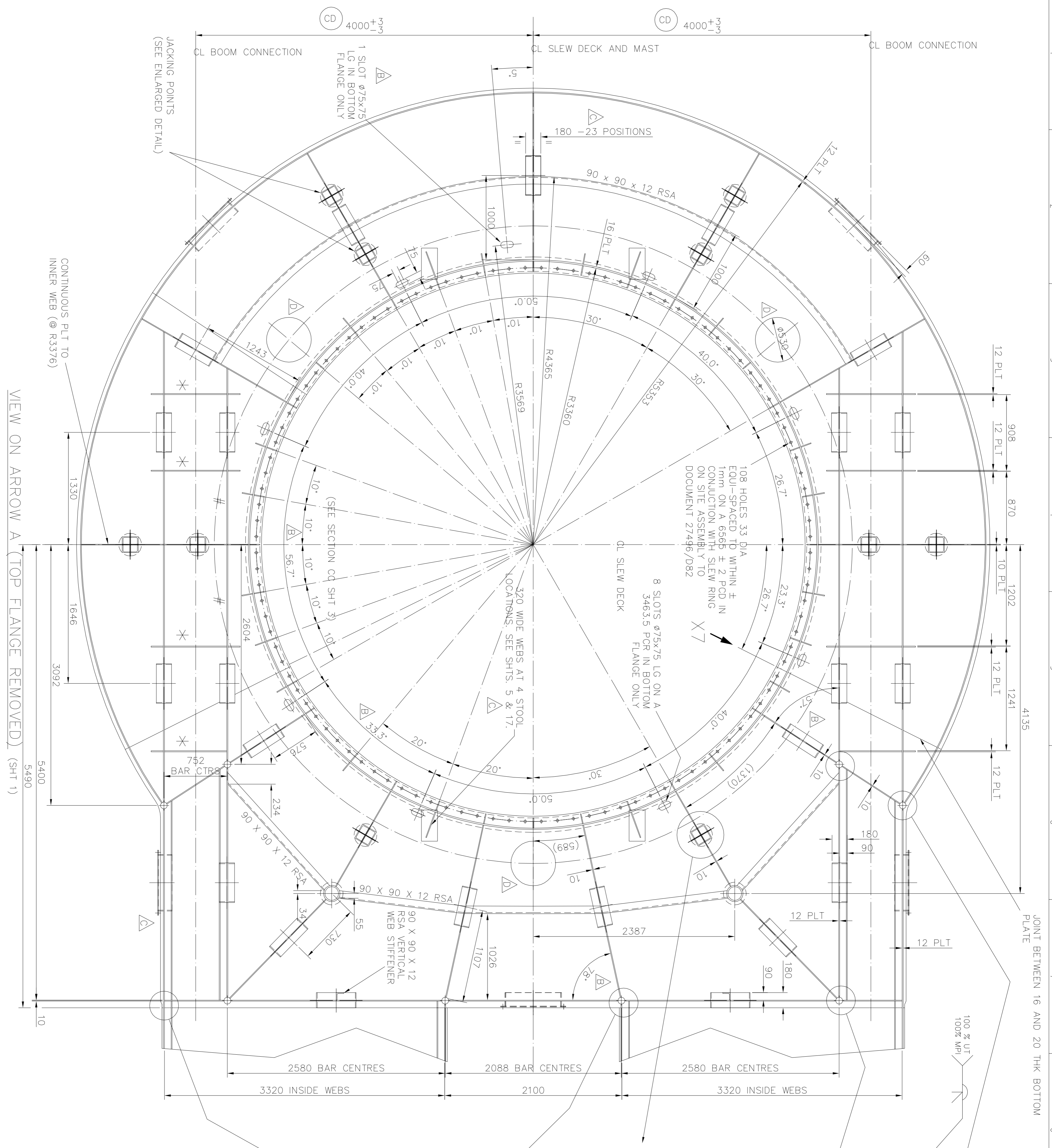

VIEW ON ARROW A (TOP FLANGE REMOVED) (SHT 1)

SCALE 1:25

DATE	APPROVED	DATE	APPROVED
DATE	APPROVED	DATE	APPROVED

ISSUES RAISED REFER TO SHEET 2 OF 17 AS BUILT

GENERALLY MODIFIED TO AS BUILT STANDARD HOLE DIAMETER PROBABLY CORRECTED AT SLEW DRIVES.

190 DIM. DELETED (GRID F7) 23 POSNS. WAS 19 (GRID D2) 320 WIDE WEBS SHOWN (D5). ADDITIONAL INTERFERENCE INFO ADDED SEE SHTS. 14-17.

REF. GRID 2D SLOT ADDED REF. GRID 9C DIMN 130 WAS 131

REF. GRID 5F SLOT MOVED TO 80 DEGREE ANGLE SIZE ADDED. GRID REF. 5B & 7C ANGLE DIMS. ADDED. SEE ALSO SHT. 1, 2, 4, 10 TO 13

DATE	APPROVED	DATE	APPROVED
DATE	APPROVED	DATE	APPROVED

UNLESS OTHERWISE SPECIFIED IDENTIFY THE ITEM WITH THE DRAWING NUMBER AND ISSUE LEVEL AT \blacktriangledown AND IN THE MANNER SHOWN FOR PAINTING AND FOR LUBRICATION SPECIFICATIONS SEE COMPONENTS LIST.

UNLESS OTHERWISE STATED DIMENSIONS ARE IN MILLIMETRES TOLERANCES UNLESS OTHERWISE STATED (PLUS OR MINUS) RANGE MACH FAB CAST

0-500 0.25 2 4

501-1000 0.5 3 6

1001-2000 1.0 4 10

ABOVE 2000 2.0 6 10

This print and all the information herein is the property of Metso Minerals. Bulk Minerals Handling Products and must not be made public, copied or used in any way detrimental to our interests. It is loaned subject to return on demand unless furnished under contract provisions.

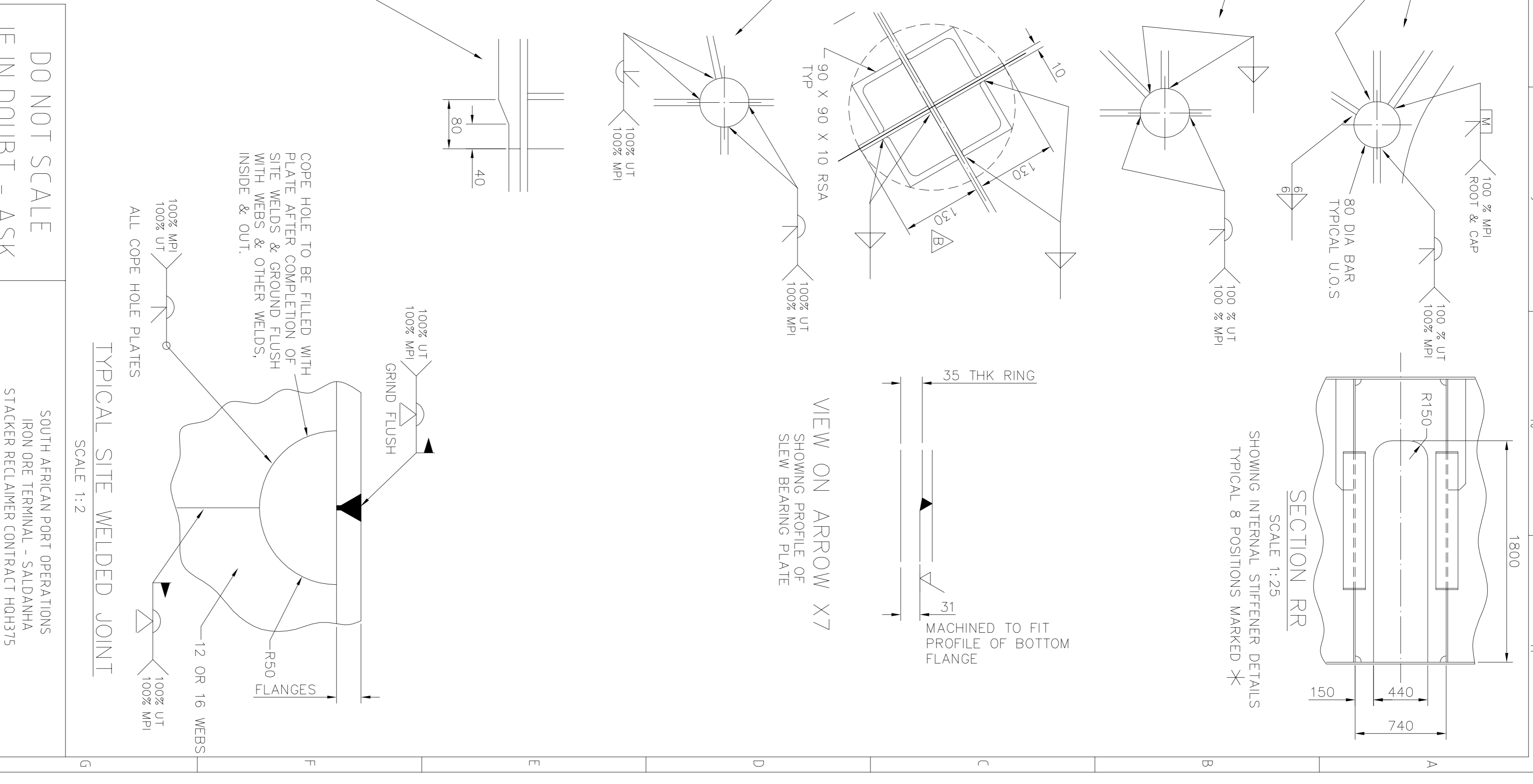

DO NOT SCALE IF IN DOUBT - ASK

SCALE 1:25

ALL COPE HOLE PLATES

COPE HOLE TO BE FILLED WITH PLATE AFTER COMPLETION OF SITE WELDS & GROUND FLUSH WITH WEBS & OTHER WELDS, INSIDE & OUT.

GRIND FLUSH

12 OR 16 WEBS

FLANGES

SECTION RR

SCALE 1:25

SHOWING INTERNAL STIFFENER DETAILS TYPICAL 8 POSITIONS MARKED *

metso minerals

SOUTH AFRICAN PORT OPERATIONS
IRON ORE TERMINAL - SALDANHA
STACKER RECLAIMER CONTRACT HQH375
SANCTION No. SB01D1

METSO MINERALS (UK) LTD
BULK MATERIALS HANDLING BRISTOL
PO BOX 821 ASHTON VALE RD
BRISTOL BS99 5ZB ENGLAND

ASSEMBLY & DETAILS OF SLEW DECK & MAST STRUCTURE

DRAWING NUMBER 700418

SHEET 3 OF 17

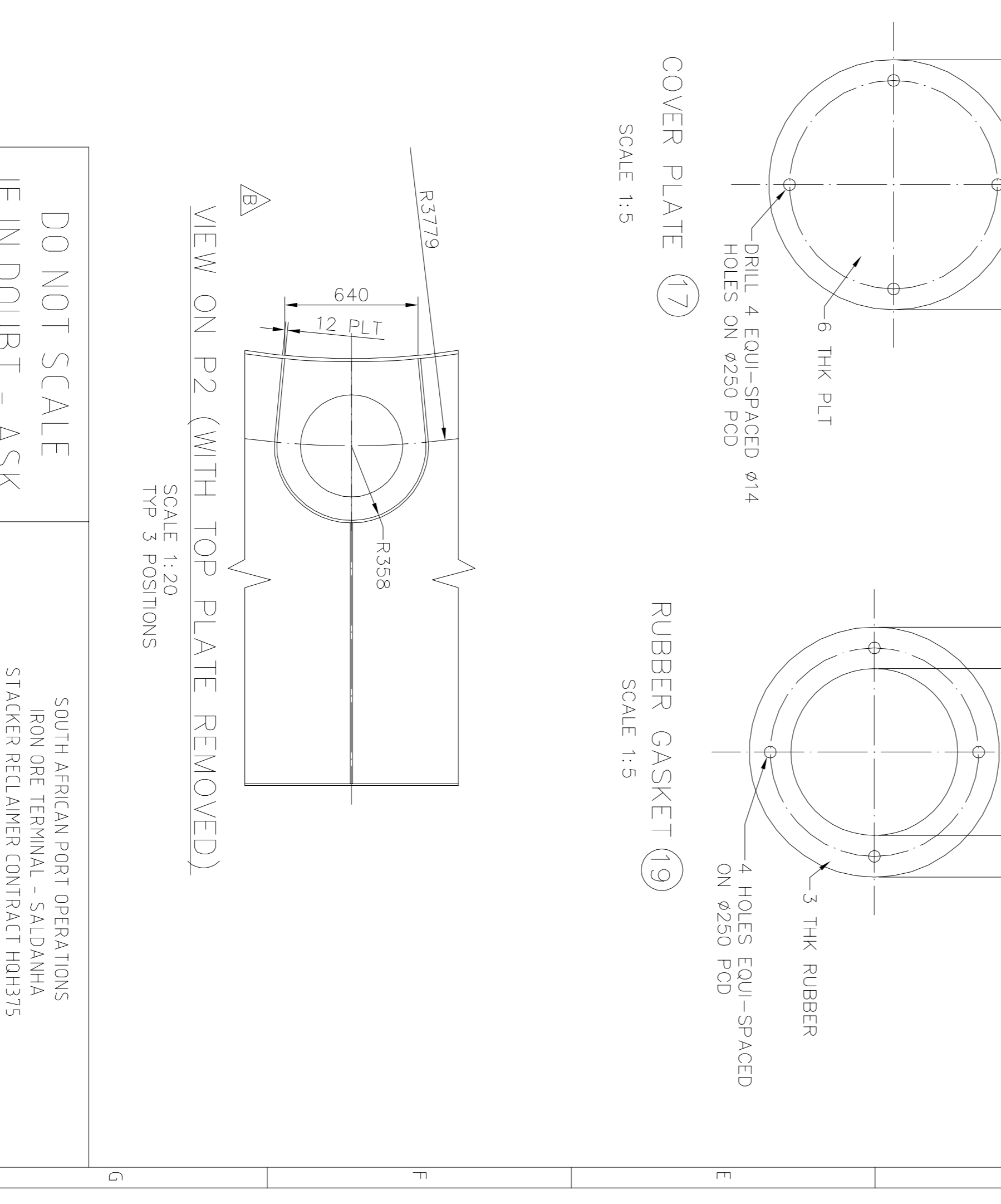
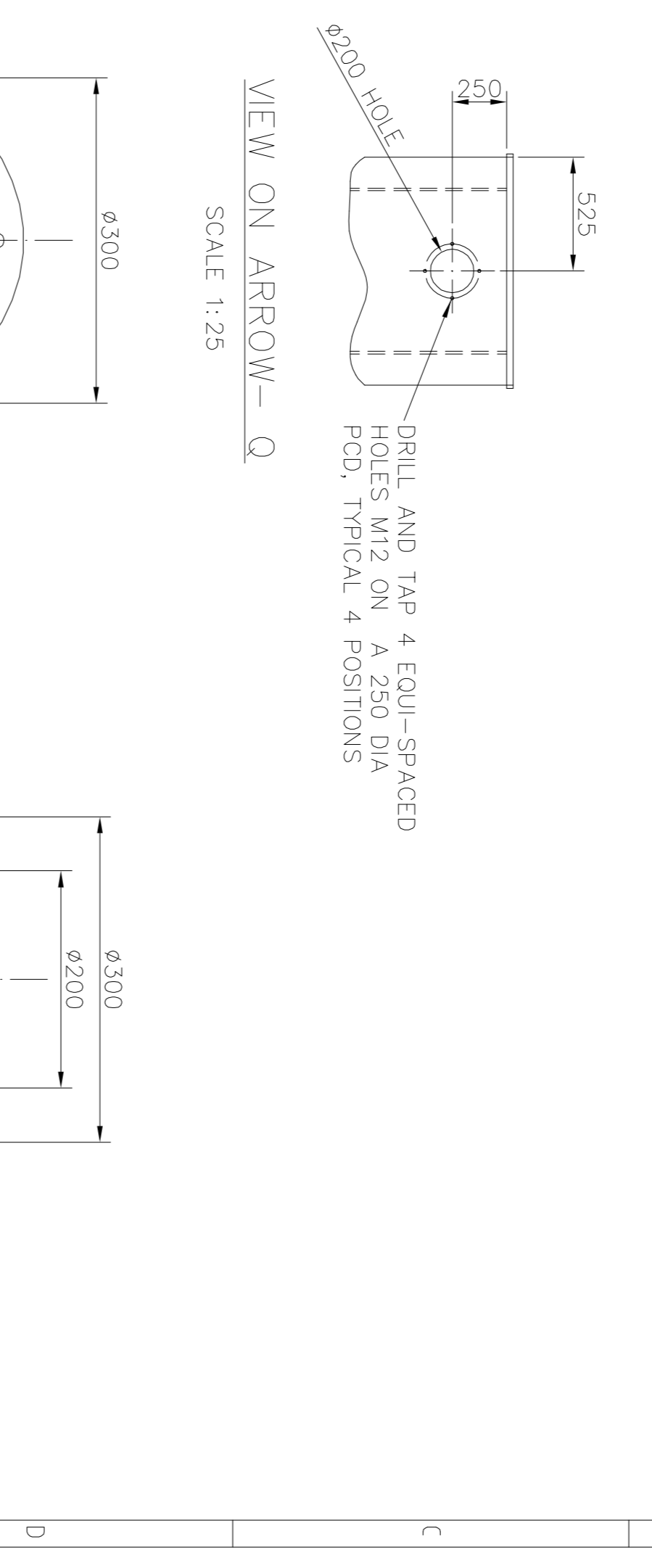
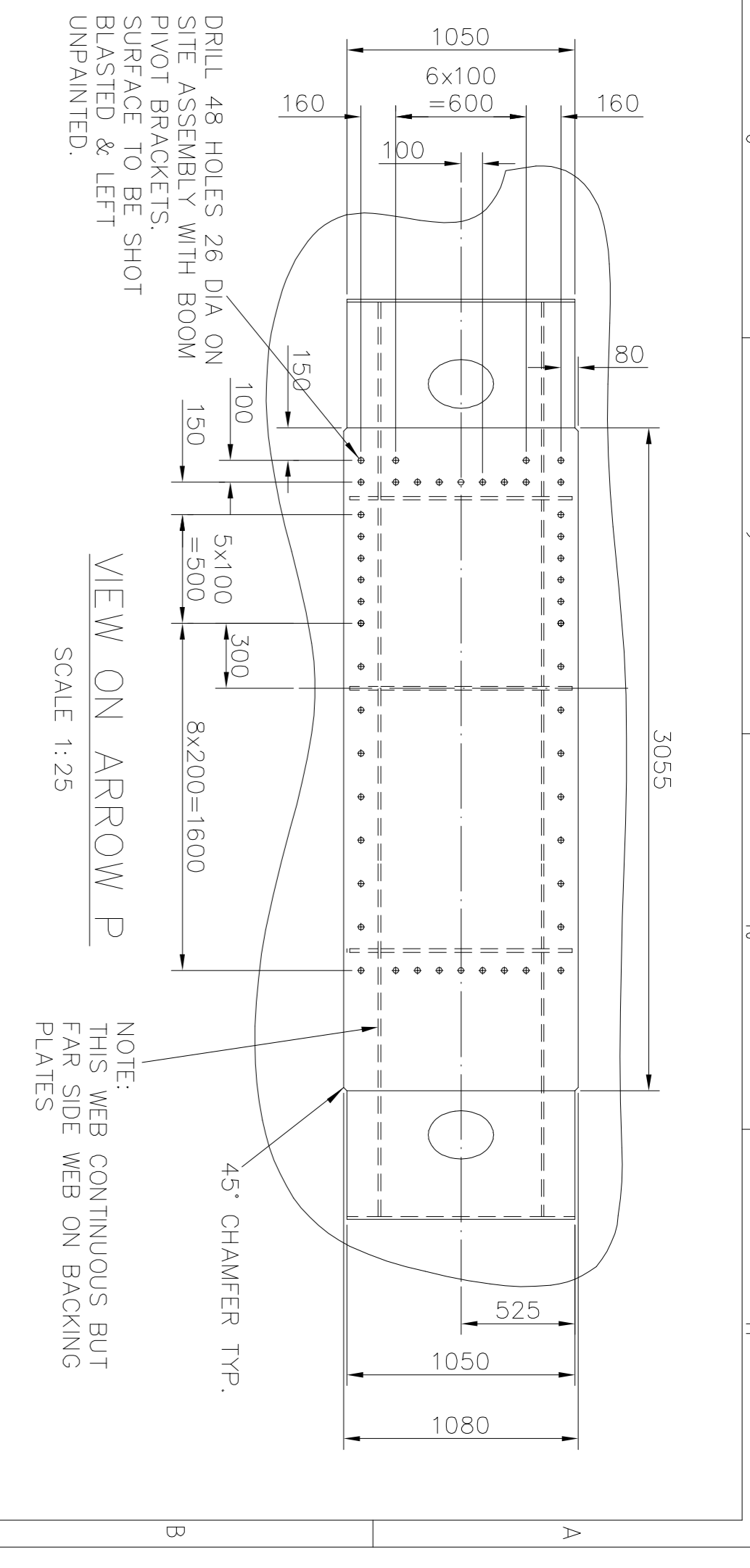
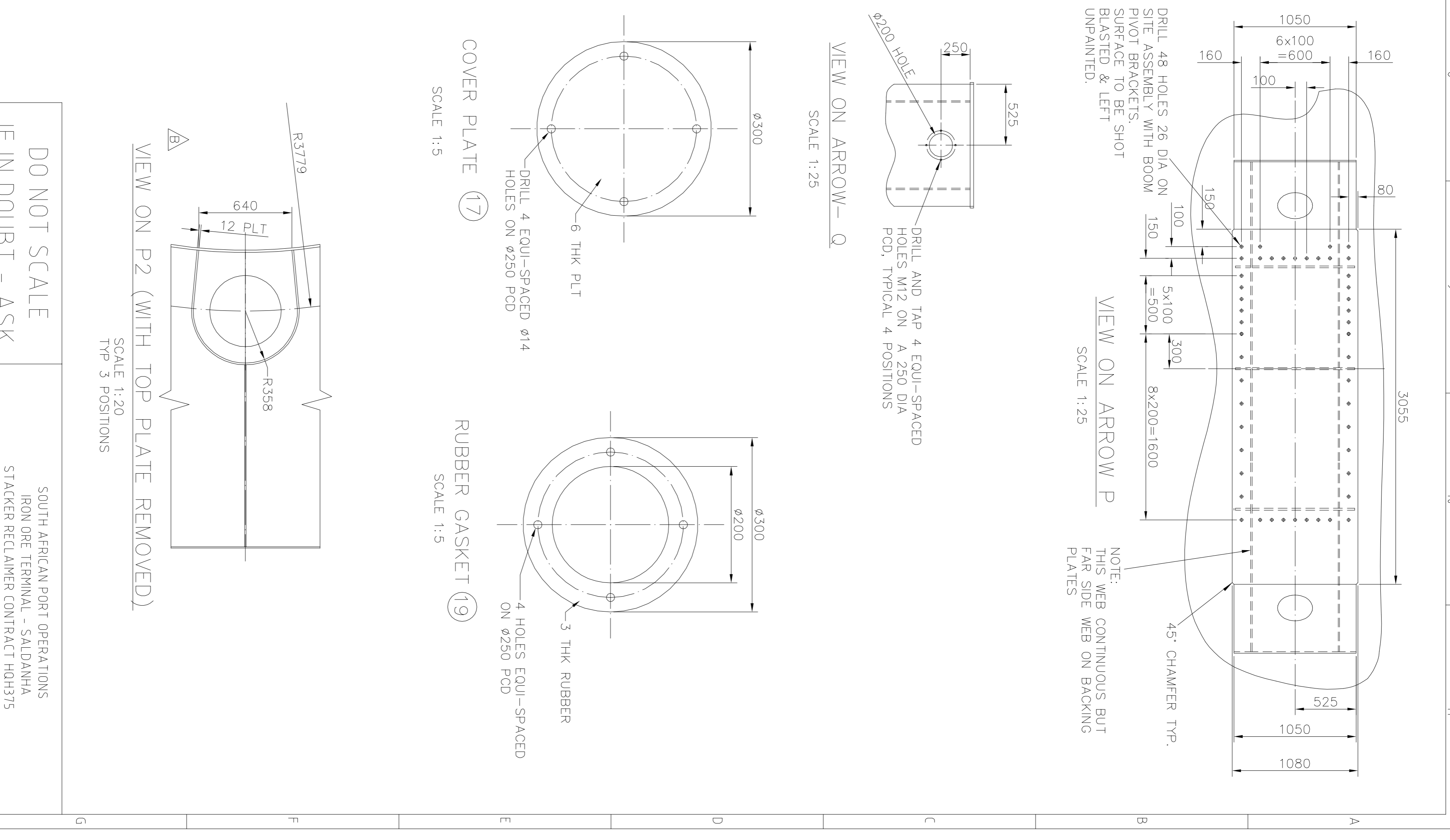
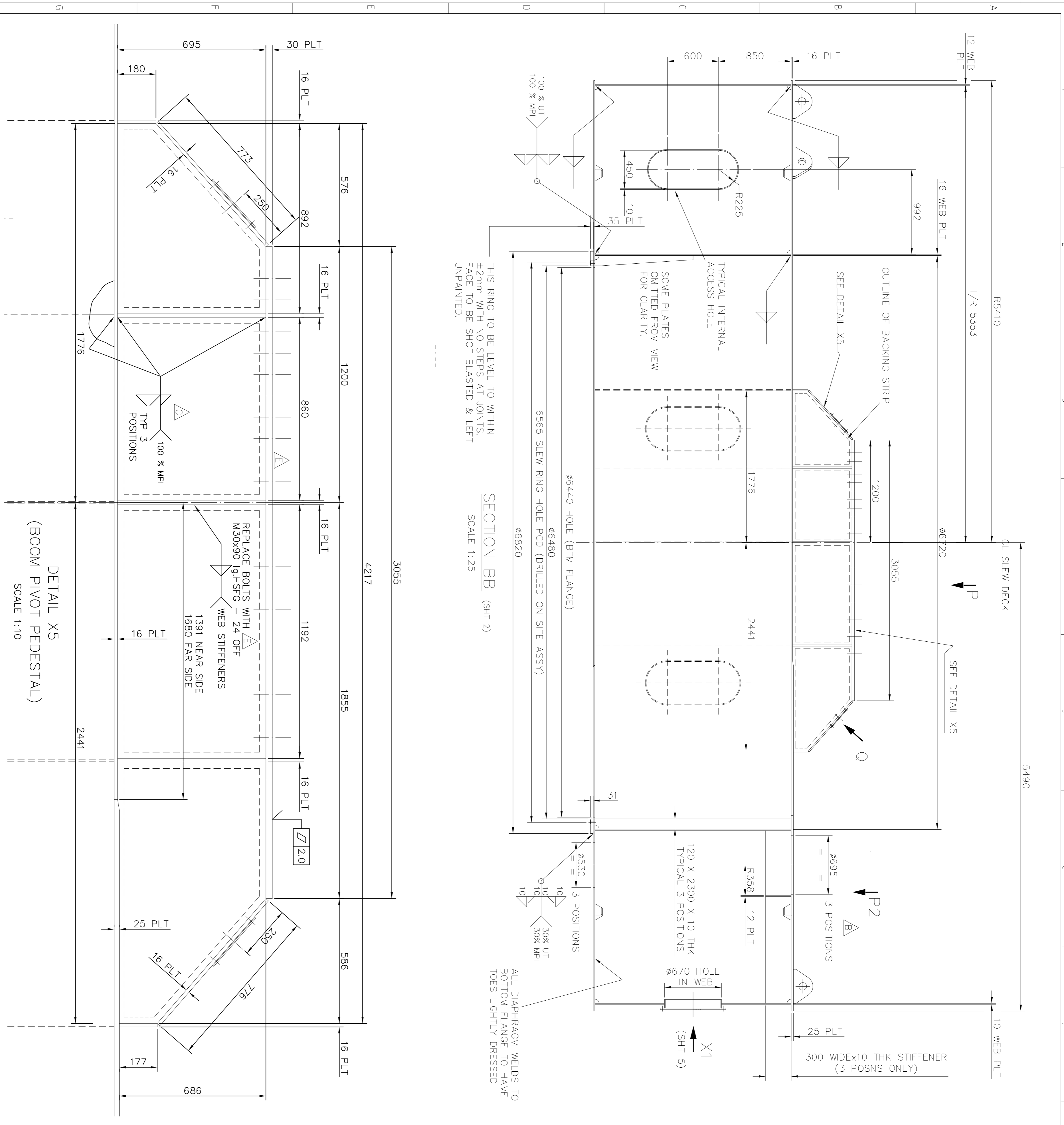

DATE	DATE	DATE	DATE	DATE	DATE	DATE	DATE	DATE	DATE	DATE	DATE	DATE	DATE	DATE	DATE	DATE	DATE	DATE	DATE			
16.02.06	22.6.06	22.6.06	DEC 04	JAN 05	JAN 05	8/10/02	18/10/02	21/10/02	15.08.02	16.08.02	16.08.02	15.06.02	29.06.02	15.7/02								
DD3	RD	JWH	DWB	CF	DWB	CF	GBL	JWH	FAB	JWH	JWH	USB	NCN	JWH								
16.02.06	22.6.06	22.6.06	DEC 04	JAN 05	JAN 05	8/10/02	18/10/02	21/10/02	15.08.02	16.08.02	16.08.02	15.06.02	29.06.02	15.7/02								

ISSUES RAISED
REPLACE STOOD SUPPORT BOLTS WITH M30x90 IGHSGC AS BUILT

GENERALLY MODIFIED TO
AS BUILT STANDARD 530 DIA. HOLE WAS 490 (06) NOTE ADDED RE: WELD DRESSING (GRD D7).

WELD DETAIL ADDED (GRD F3)
ADDITIONAL INTERLOC INFO ADDED. SEE SHIS 14-17.

REF SECTION BB SLEW DRIVE
DETAILS FINALISED VIEW ON P2 ADDED SEE ALSO SHIS 1 TO 3 & 5 TO 13

ISSUED FOR MANUFACTURE

UNLESS OTHERWISE SPECIFIED IDENTIFY THE ITEM WITH THE DRAWING NUMBER AND ISSUE LEVEL AT THE END IN THE MANNER SHOWN FOR PAINTING AND FOR LUBRICATION SPECIFICATIONS SEE COMPONENTS LIST

UNLESS OTHERWISE STATED DIMENSIONS ARE IN MILLIMETERS UNLESS OTHERWISE STATED (PLUS OR MINUS)

TOLERANCES UNLESS OTHERWISE STATED (PLUS OR MINUS)

RANGE	MACH	FAB	CAST
0-500	0.25	2	4
501-2000	10	3	6
ABOVE 2000	20	4	10

THIS PRINT AND ALL THE INFORMATION HEREON IS THE PROPERTY OF METSO MINERALS. BULK MATERIALS HANDLING BRISTOL. COPIED OR USED IN ANY MANNER WITHOUT THE WRITTEN PERMISSION OF METSO MINERALS WILL BE CONSIDERED A BREACH OF CONTRACT. PROVISIONS FOR RETURN ON DEMAND UNLESS FURNISHED UNDER CONTRACT PROVISIONS.

DO NOT SCALE IF IN DOUBT - ASK

SOUTH AFRICAN PORT OPERATIONS
IRON ORE TERMINAL - SALDANHA
STACKER RECLAIMER CONTRACT HQH375
SANCTION No. SB01 D1

METSO MINERALS (UK) LTD
BULK MATERIALS HANDLING BRISTOL
PO BOX 821 ASHTON VALE RD
BRISTOL BS99 5ZB ENGLAND

ASSEMBLY & DETAILS OF SLEW DECK & MAST STRUCTURE

700418

4 SHEETS OF **17** ISSUE

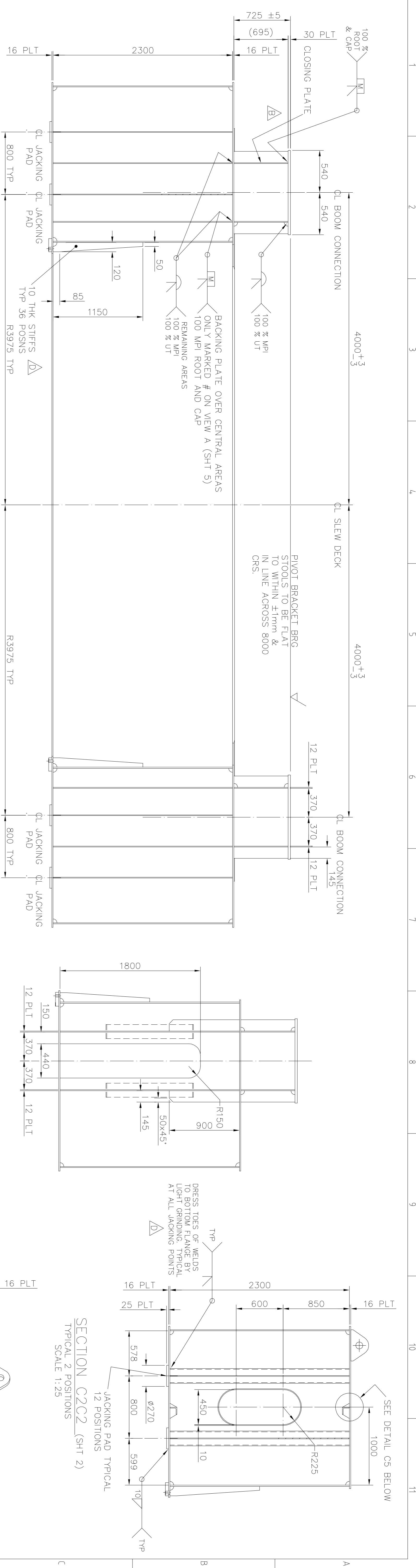

SECTION CC (SHT 2)
SCALE 1:25

SECTION C1C1 (SHT 2)
SCALE 1:25

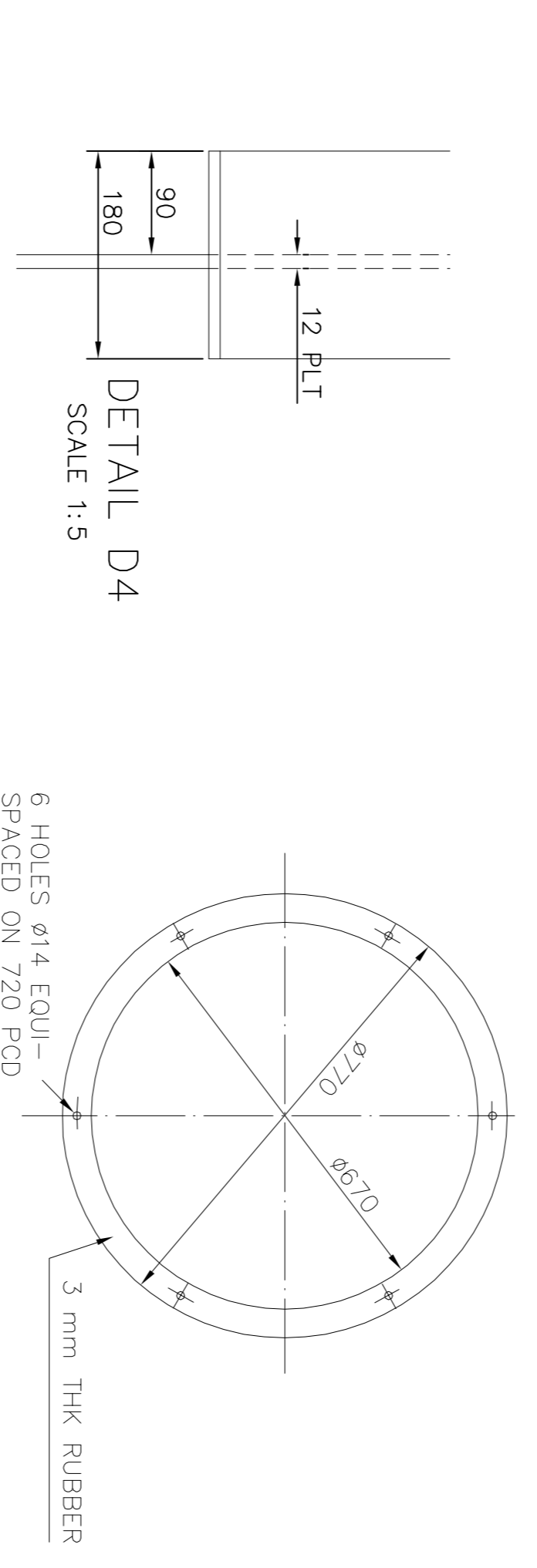

DETAIL D4
SCALE 1:5

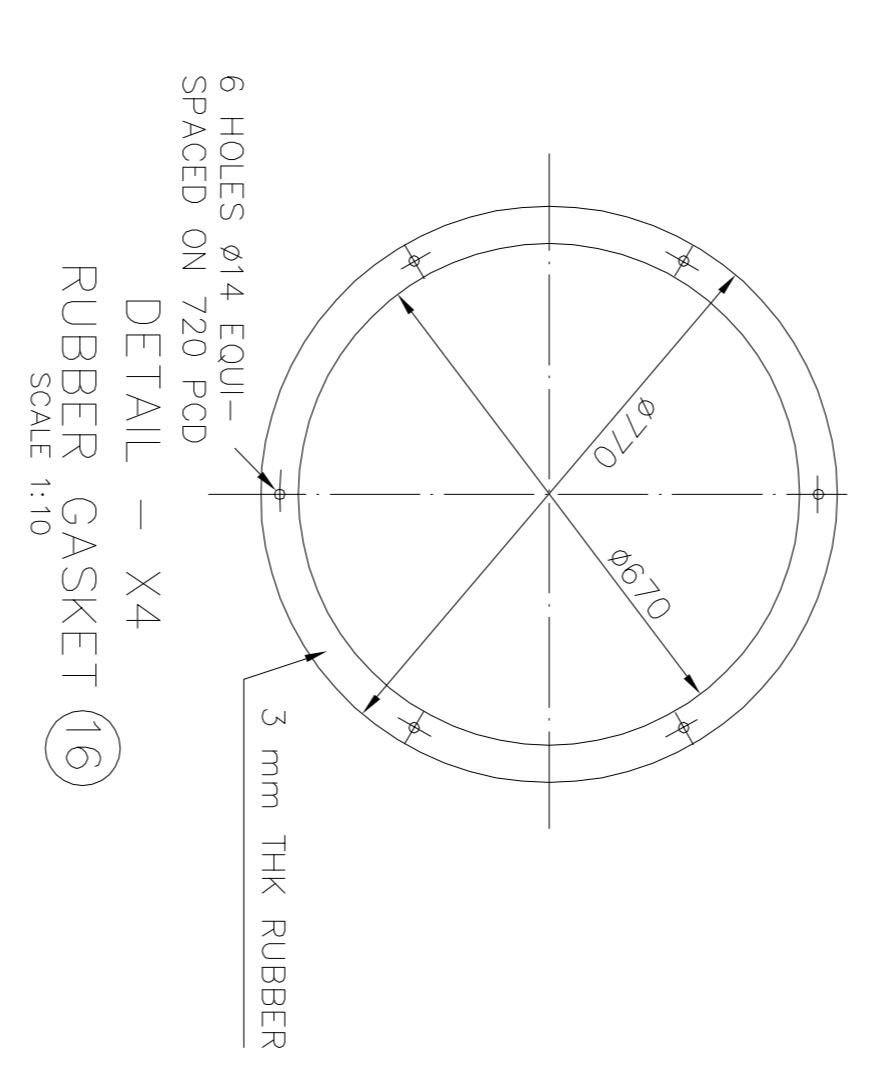

DETAIL - X4
SCALE 1:10

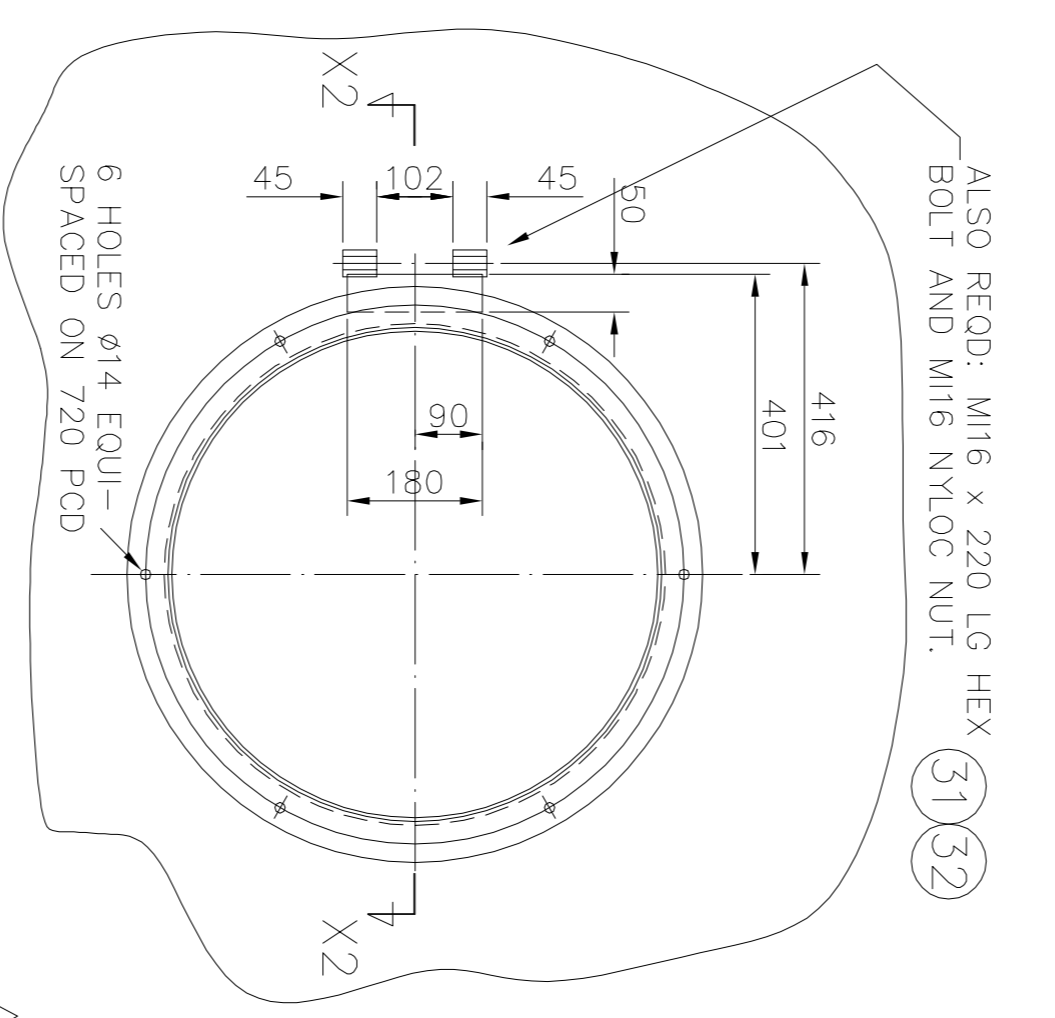

VIEW ON ARROW X1 (SHT 4.8)
SCALE 1:10

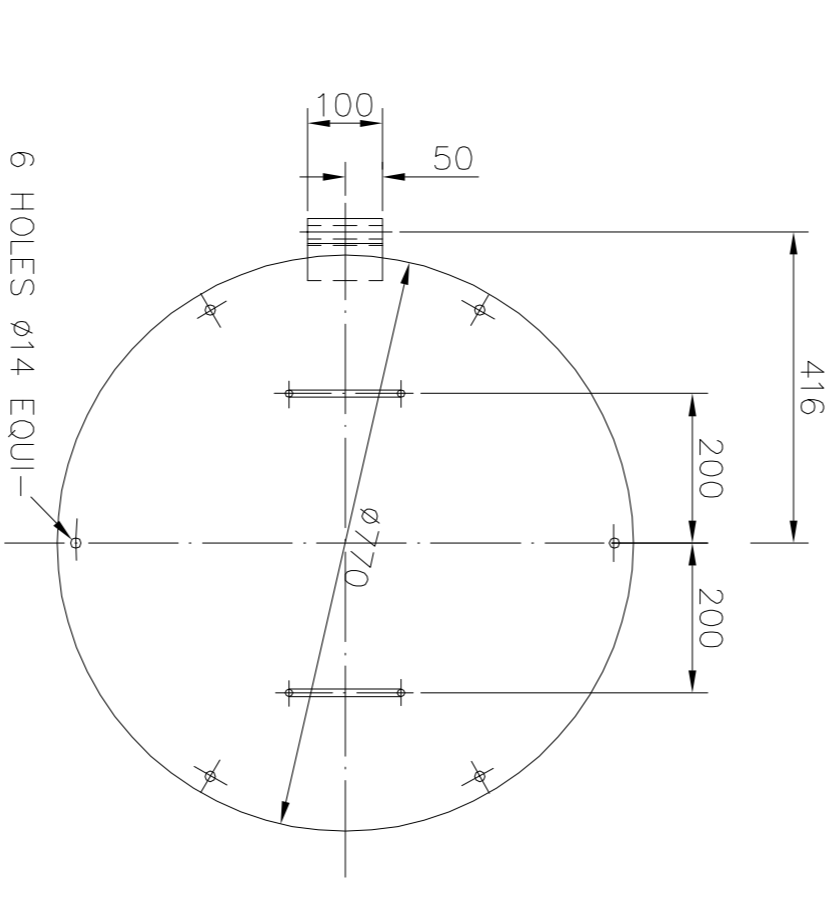

HINGED COVER - X3
SCALE 1:10

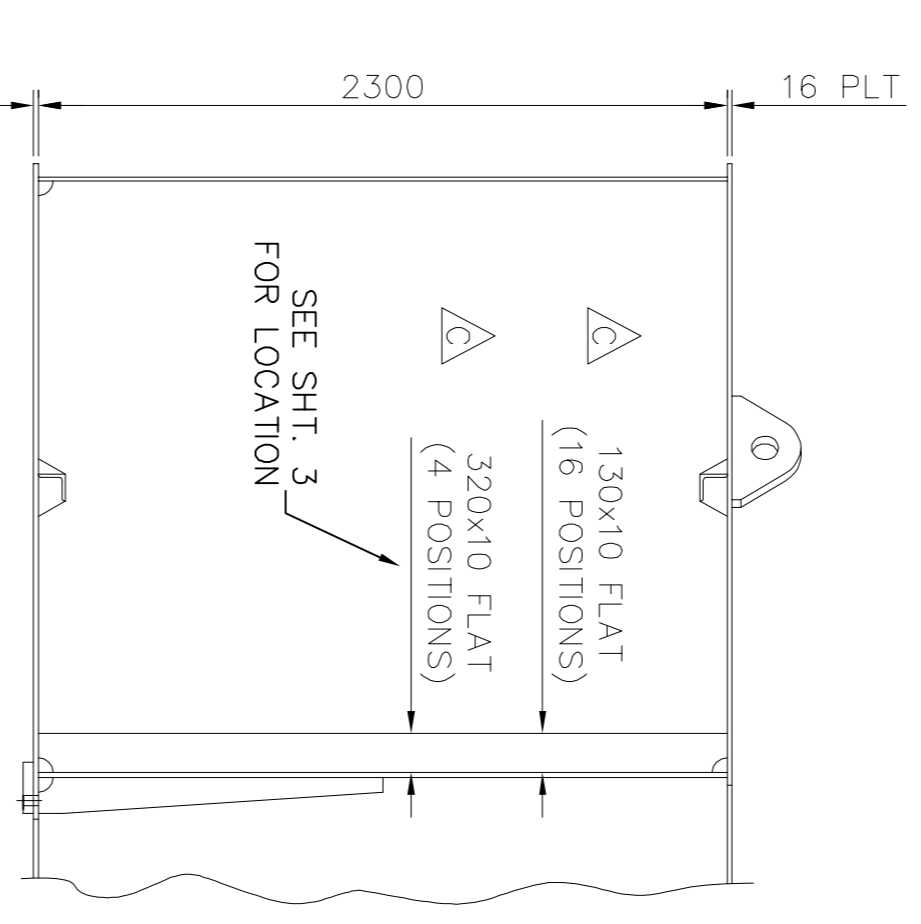

SECTION C4C4 (SHT 2)
SCALE 1:25

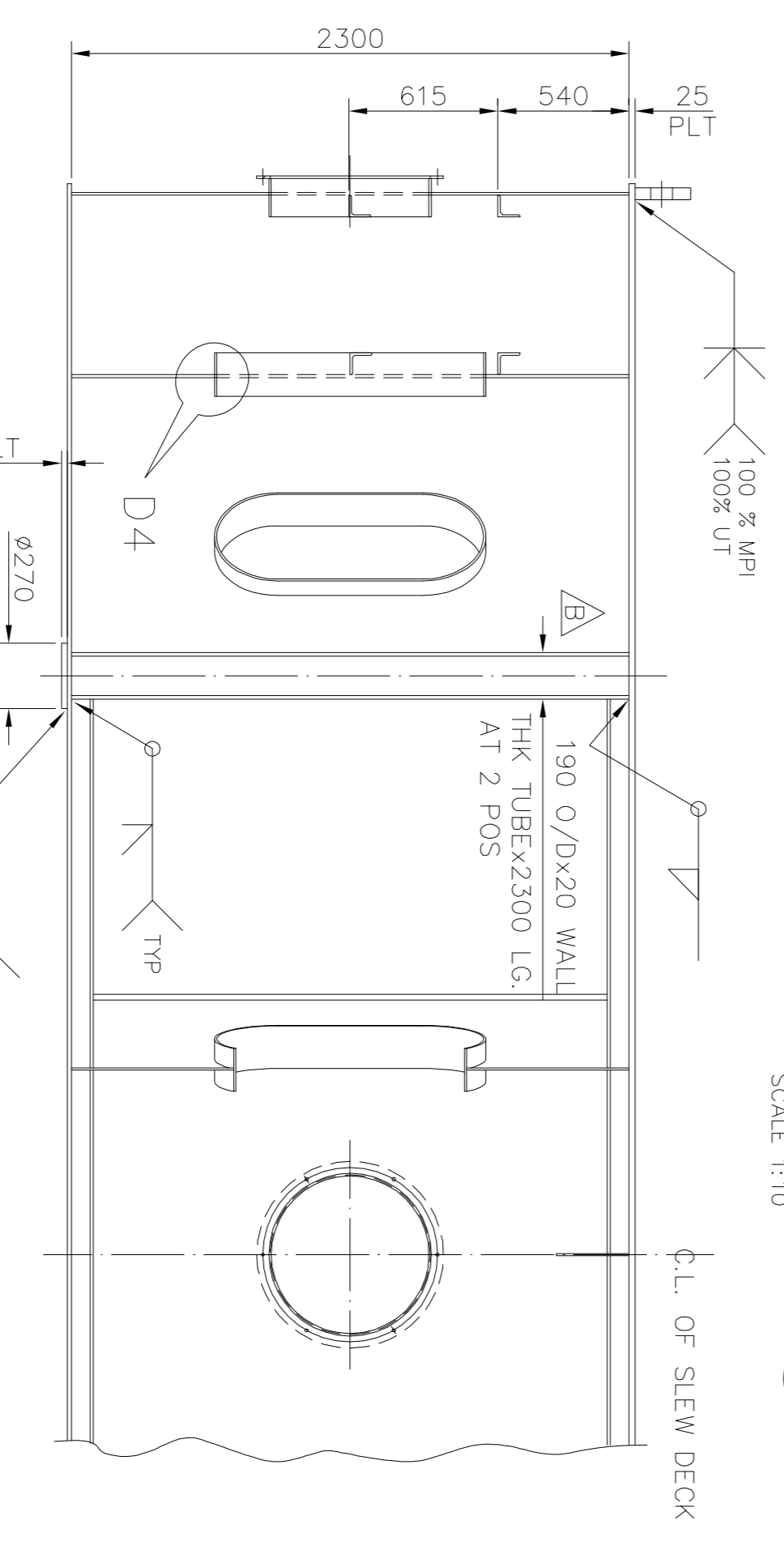

SECTION C3C3 (SHT 2)
SCALE 1:25

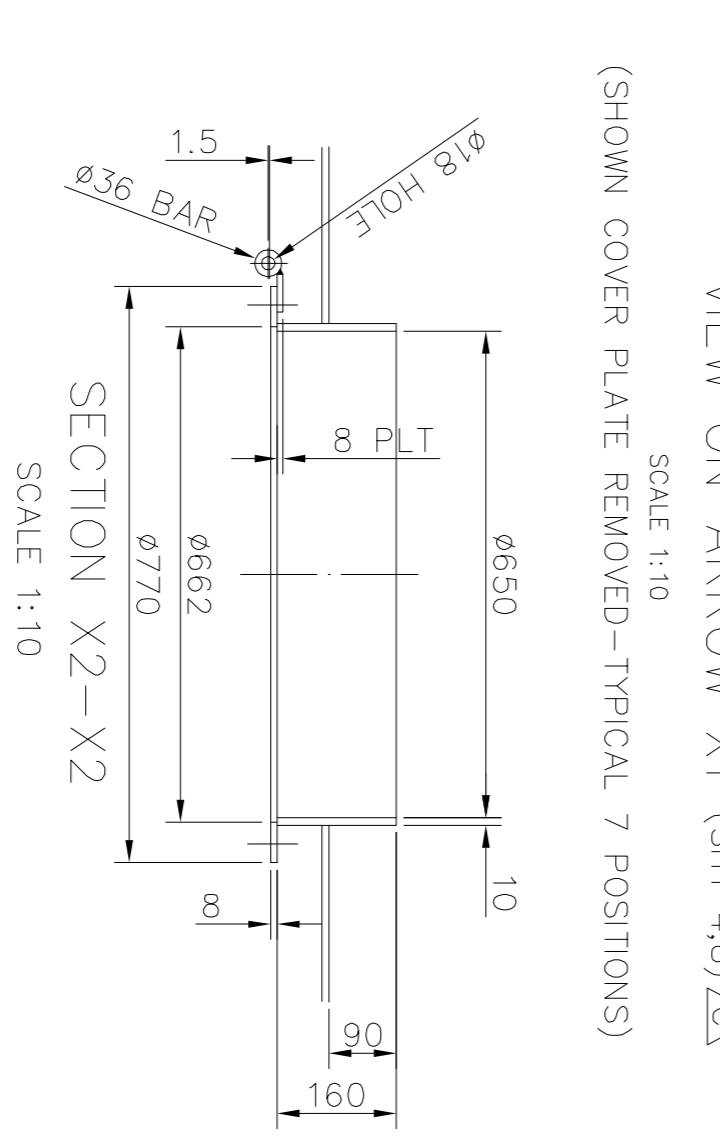

SECTION X2-X2
SCALE 1:10

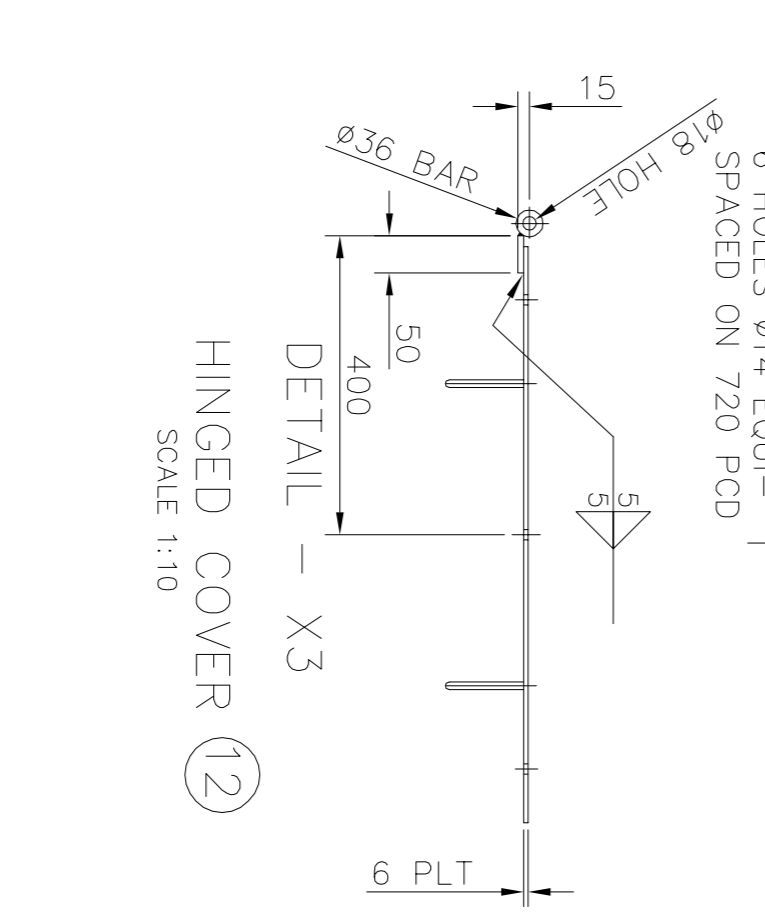

DETAIL C5
SCALE 1:5

DATE	APPROVED	CHECKED	DATE	APPROVED	CHECKED	DATE	APPROVED	CHECKED	DATE	APPROVED	CHECKED	DATE	APPROVED	CHECKED	DATE	APPROVED	CHECKED	DATE	APPROVED						
16/02/06	DDB	16/02/06	RD	22/6/06	JWH	22/6/06	DWB	8/10/02	CF	18/10/02	GBL	21/10/02	JWH	15/08/02	FAB	15/08/02	JWH	16/08/02	USB	15/06/02	NCN	29/06/02	JWH	15/7/02	JWH

ISSUES RAISED AS BUILT REFER TO SHEET 2 OF 17

GENERALLY MODIFIED TO AS BUILT STANDARD NOTE: ADD RE WELD DRESSING (GRID B9) 36 POSNS. WAS 34 (GRID C3)

34 POSNS. WAS 33 (GRID C3) FLAT THICKNESS ADDED (GRID D10) 120x10 FLATS ADDED. ADDITIONAL INTERLACE INFO. ADDED. SEE SHTS. 14-17.

REF. SECTION CC COPE HOLES REMOVED. REF. SECTION C3C3. TUBE WAS 94 OD 16 WALL. REF. SECTION C4C4 130 FLAT WAS 230. SEE ALSO SHTS 1 TO 4

UNLESS OTHERWISE SPECIFIED IDENTIFY THE ITEM WITH THE DRAWING NUMBER AND ISSUE LEVEL AT AND IN THE MANNER SHOWN FOR PAINTING AND FOR LUBRICATION SPECIFICATIONS SEE COMPONENTS LIST.

UNLESS OTHERWISE STATED DIMENSIONS ARE IN MILLIMETRES TOLERANCES UNLESS OTHERWISE STATED PLUS OR MINUS

RANGE	MACH	FAB	CAST
0-500	0.25	2	2
501-1000	0.5	3	4
1001-2000	1.0	4	6
ABOVE 2000	2.0	6	10

THIS PRINT AND ALL THE INFORMATION HEREON IS THE PROPERTY OF METSO MINERALS. Bulk Materials Handling Products and must not be made public, copied or used in any way detrimental to our interests. It is loaned subject to return on demand unless furnished under contract provisions.

DO NOT SCALE IF IN DOUBT - ASK

metso minerals

SOUTH AFRICAN PORT OPERATIONS
IRON ORE TERMINAL - SALDANHA
STACKER RECLAIMER CONTRACT HQH375
SANCTION NO. SB01D1

METSO MINERALS (UK) LTD
BULK MATERIALS HANDLING BRISTOL
PO BOX 821 ASHTON VALE RD
BRISTOL BS99 5ZB ENGLAND

ASSEMBLY & DETAILS OF SLEW DECK & MAST STRUCTURE

DRAMA TO BS 8888
WELDS SYMBOLS TO BS EN 2553
SURFACE TREATMENT TO BS 5400
MATERIAL & CONDITION BEFORE MANUFACTURE

MAINT. SEE SHT 1
SPEC. SEE SHT 1
GRADE SEE SHT 1

MASS SEE SHT 1
ORIGINAL SCALE AS SHOWN

SIZE DRAWING NUMBER A1 700418

SHEET 5 OF 17
ISSUE E

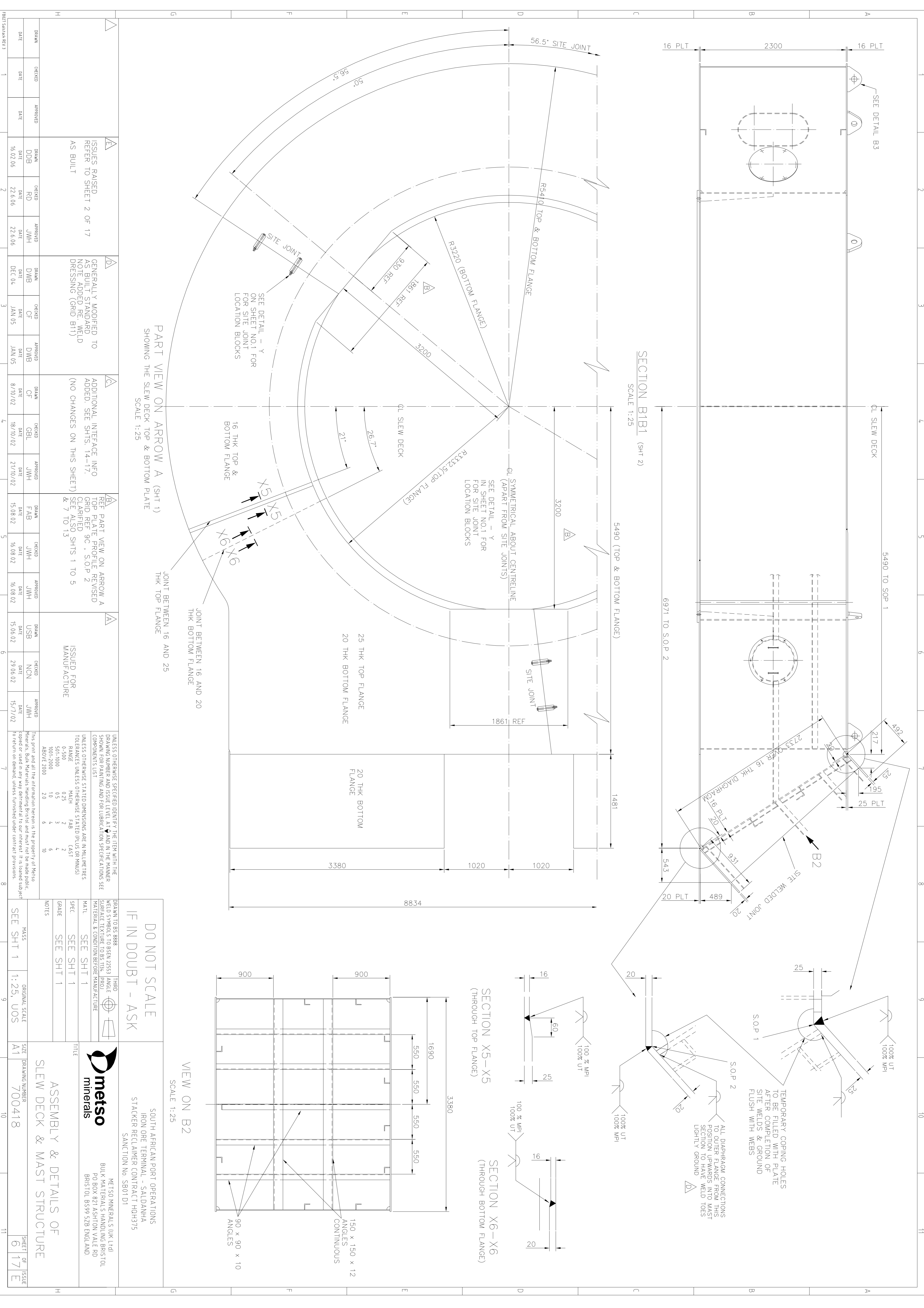

DATE	DESCRIPTION	APPROVED	DATE	DESCRIPTION	APPROVED
16.02.06	ISSUES RAISED REFER TO SHEET 2 OF 17 AS BUILT	DDB	22.6.06	ISSUES RAISED REFER TO SHEET 2 OF 17 AS BUILT	RJ
22.6.06	ISSUES RAISED REFER TO SHEET 2 OF 17 AS BUILT	DDB	22.6.06	ISSUES RAISED REFER TO SHEET 2 OF 17 AS BUILT	RJ

ISSUES RAISED REFER TO SHEET 2 OF 17 AS BUILT

GENERAL PRACTICE MODIFIED TO AS BUILT STANDARD NOTE ADDED RE: WELD DRESSING (GRID B1)

ADDITIONAL INTERFACE INFO ADDED. SEE SHTS. 14-17. (NO CHANGES ON THIS SHEET)

REF. PART VIEW ON ARROW A TOP PLATE PROFILE REVISED CLEARLY SEE ALSO SHTS 1 TO 5 & 7 TO 13

DATE	DESCRIPTION	APPROVED
15.08.02	ISSUED FOR MANUFACTURE	USB
15.07.02	ISSUED FOR MANUFACTURE	NCN
15.07.02	ISSUED FOR MANUFACTURE	JWH

DO NOT SCALE IF IN DOUBT - ASK

DRWING NO	BS 8888	THIRD	ANGLE
WELD SYMBOLS TO BS EN 2254			
ZONAL TEXT TO BS EN 2254			
MATERIAL & CONDITION BEFORE MANUFACTURE			
SEE SHT 1			
SEE SHT 1			
SEE SHT 1			
SEE SHT 1			

UNLESS OTHERWISE SPECIFIED IDENTIFY THE ITEM WITH THE DRAWING NUMBER AND ISSUE LEVEL AT AND IN THE MANNER SHOWN FOR PAINTING AND FOR LUBRICATION SPECIFICATIONS SEE COMPONENTS LIST

TOLERANCES UNLESS OTHERWISE STATED ARE IN MILLIMETRES UNLESS OTHERWISE STATED (PLUS OR MINUS)

RANGE	MACH	FAB	CAST
0-500	0.25	2	2
501-1000	0.5	3	4
1001-2000	1.0	4	6
ABOVE 2000	2.0	6	10

This print and all the information herein is the property of Metso Minerals. Bulk Materials Handling Bristol and must not be made public, copied or used in any way detrimental to our interest. It is loaned subject to return on demand, unless furnished under contract provisions.

metso minerals

MEITSO MINERALS (UK) LTD
 BULK MATERIALS HANDLING BRISTOL
 PO BOX 821 ASHTON VALE RD
 BRISTOL BS99 5ZB ENGLAND

SOUTH AFRICAN PORT OPERATIONS
 IRON ORE TERMINAL - SALDANHA
 STACKER RECLAIMER CONTRACT HQH375
 SANCTION NO. SB01D1

ASSEMBLY & DETAILS OF SLEW DECK & MAST STRUCTURE

ORIGINAL SCALE: 1:25, UOS
 SIZE: A1
 DRAWING NUMBER: 700418
 SHEET OF: 6
 ISSUE: 17E

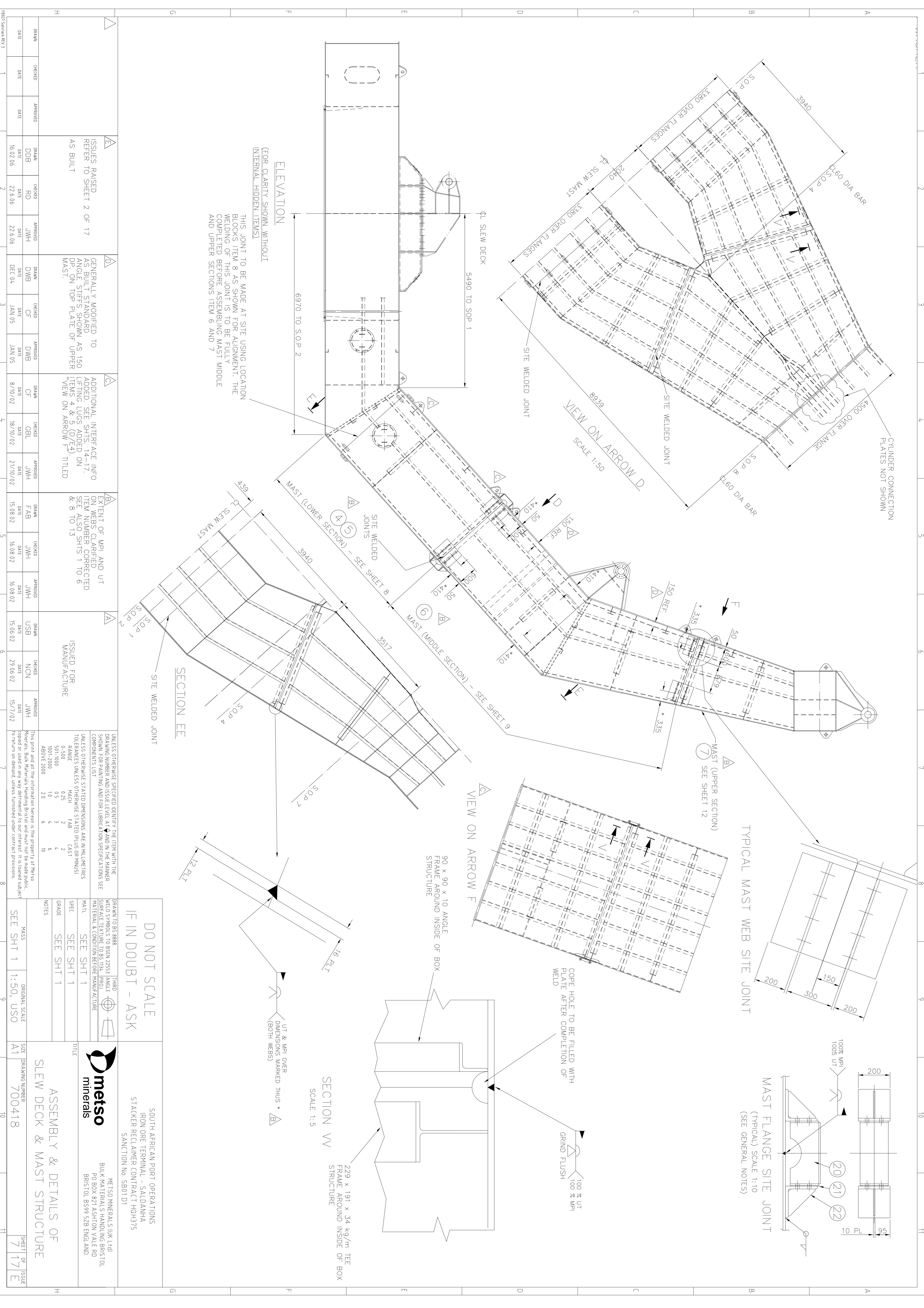

DATE	CHECKED	DATE	APPROVED
16.02.06	DDB	16.02.06	DDB
22.6.06	RD	22.6.06	JWH

DATE	CHECKED	DATE	APPROVED
16.02.06	DDB	16.02.06	DDB
22.6.06	RD	22.6.06	JWH
DEC 04	DWB	DEC 04	DWB
JAN 05	CF	JAN 05	DWB
8/10/02	CF	8/10/02	CF
18/10/02	GBL	18/10/02	GBL
21/10/02	JWH	21/10/02	JWH
15.08.02	FAB	15.08.02	FAB
16.08.02	JWH	16.08.02	JWH
16.08.02	JWH	16.08.02	JWH
15.06.02	USB	15.06.02	USB
29.06.02	NCN	29.06.02	NCN
15.7/02	JWH	15.7/02	JWH

DATE	CHECKED	DATE	APPROVED
16.02.06	DDB	16.02.06	DDB
22.6.06	RD	22.6.06	JWH
DEC 04	DWB	DEC 04	DWB
JAN 05	CF	JAN 05	DWB
8/10/02	CF	8/10/02	CF
18/10/02	GBL	18/10/02	GBL
21/10/02	JWH	21/10/02	JWH
15.08.02	FAB	15.08.02	FAB
16.08.02	JWH	16.08.02	JWH
16.08.02	JWH	16.08.02	JWH
15.06.02	USB	15.06.02	USB
29.06.02	NCN	29.06.02	NCN
15.7/02	JWH	15.7/02	JWH

DO NOT SCALE
IF IN DOUBT - ASK

metso minerals
SOUTH AFRICAN PORT OPERATIONS
IRON ORE TERMINAL - SALDANHA
STACKER RECLAIMER CONTRACT HQH375
SANCTION No. SB01011

BUK MATERIALS HANDLING BRISTOL
PO BOX 821 ASHTON VALE RD
BRISTOL BS99 5ZB ENGLAND

ASSEMBLY & DETAILS OF
SLEW DECK & MAST STRUCTURE

METSO MINERALS (UK) LTD
BUK MATERIALS HANDLING BRISTOL
PO BOX 821 ASHTON VALE RD
BRISTOL BS99 5ZB ENGLAND

THIS PRINT AND ALL THE INFORMATION HEREON IS THE PROPERTY OF METSO MINERALS. BUK MATERIALS HANDLING BRISTOL AND MUST NOT BE MADE PUBLIC, COPIED OR USED IN ANY WAY DETRIMENTAL TO OUR INTEREST. IT IS LOANED SUBJECT TO RETURN ON DEMAND, UNLESS OTHERWISE STATED UNDER CONTRACT PROVISIONS.

DATE	CHECKED	DATE	APPROVED
16.02.06	DDB	16.02.06	DDB
22.6.06	RD	22.6.06	JWH
DEC 04	DWB	DEC 04	DWB
JAN 05	CF	JAN 05	DWB
8/10/02	CF	8/10/02	CF
18/10/02	GBL	18/10/02	GBL
21/10/02	JWH	21/10/02	JWH
15.08.02	FAB	15.08.02	FAB
16.08.02	JWH	16.08.02	JWH
16.08.02	JWH	16.08.02	JWH
15.06.02	USB	15.06.02	USB
29.06.02	NCN	29.06.02	NCN
15.7/02	JWH	15.7/02	JWH

ISSUES RAISED
REFER TO SHEET 2 OF 17
AS BUILT

GENERALY MODIFIED TO
AS BUILT STANDARD
ANGLE STIFFS SHOWN AS 150
DP ON TOP PLATE OF UPPER
MAST.

ADDITIONAL INTERFACE INFO
ADDED. SEE SHITS 4-17.
LIFTING LOGS ADDED ON
ITEMS 4 & 9 (D/E) TITLED
VIEW ON ARROW F.

EXTENT OF MPI AND UT
ON WEBS CLARIFIED
ITEM NUMBER CORRECTED
SEE ALSO SHITS 1 TO 6
& 8 TO 13

ISSUED FOR
MANUFACTURE

UNLESS OTHERWISE SPECIFIED IDENTIFY THE ITEM WITH THE DRAWING NUMBER AND ISSUE LEVEL AND IN THE MANNER SHOWN FOR PAINTING AND FOR LUBRICATION SPECIFICATIONS SEE COMPONENTS LIST	UNLESS OTHERWISE STATED DIMENSIONS ARE IN MILLIMETERS
TOLERANCES UNLESS OTHERWISE STATED (PLUS OR MINUS)	
RANGE	MACH
0-500	FAB
501-1000	CAST
1001-2000	
ABOVE 2000	
2.0	2.0
4	4
6	6
10	10

SECTION U2 U2
SCALE 1:5

90x90x10 ANGLE

④ MAST LOWER
SECTION
(SHT 1 & 9)

SECTION E1E1

SECTION UU
(TYPICAL)
SCALE 1:5

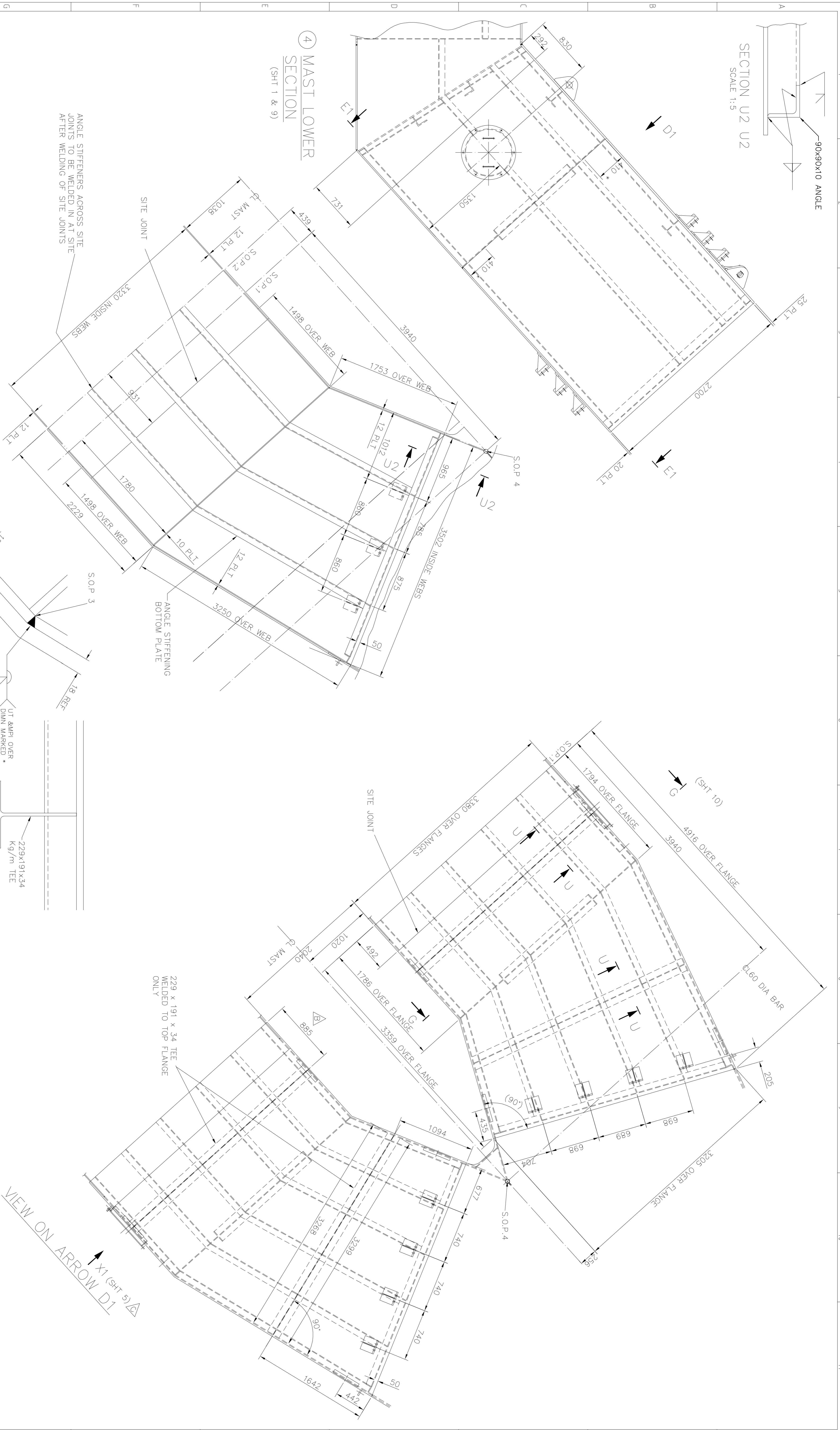

ISSUES RAISED REFER TO SHEET 2 OF 17 AS BUILT

GENERALLY MODIFIED TO AS BUILT STANDARD

ADDITIONAL INTERFACE INFO. ADDED. SEE SHTS. 14-17. LIGHTING LUGS ADDED.

REF VIEW ON ARROW D1 DIMN 885 ADDED. SEE ALSO SHTS 1 TO 7 & 9 TO 13

ISSUED FOR MANUFACTURE

UNLESS OTHERWISE SPECIFIED IDENTIFY THE ITEM WITH THE DRAWING NUMBER AND ISSUE LEVEL AT THE END IN THE MANNER SHOWN FOR PAINTING AND FOR LUBRICATION SPECIFICATIONS SEE COMPONENTS LIST.
TOLERANCES UNLESS OTHERWISE STATED PLUS OR MINUS
RANGE MACH FAB CAST
0-500 0.25 2 4
501-1000 0.5 3 6
1001-2000 1.0 4 10
ABOVE 2000 2.0 6 10

THIS PRINT AND ALL THE INFORMATION HEREON IS THE PROPERTY OF METSO MINERALS. BULK MATERIALS HANDLING BRISTOL IS COPIED OR USED IN ANY WAY DETRIMENTAL TO OUR INTEREST. IT IS LOANED SUBJECT TO RETURN ON DEMAND UNLESS TURNED OVER UNDER CONTRACT PROVISIONS.

DO NOT SCALE
IF IN DOUBT - ASK

SOUTH AFRICAN PORT OPERATIONS
IRON ORE TERMINAL - SALDANHA
STACKER RECLAIMER CONTRACT HQH375
SANCTION NO. SB01D1

metso minerals

DATE	APPROVED	DATE	APPROVED	DATE	APPROVED
16.02.06	DDB	22.6.06	JWH	DEC.04	DWB

DATE	CHECKED	DATE	CHECKED	DATE	CHECKED
	RD		CF		CF

DATE	CHECKED	DATE	CHECKED	DATE	CHECKED
	RD		CF		CF

DATE	CHECKED	DATE	CHECKED	DATE	CHECKED
	RD		CF		CF

DATE	CHECKED	DATE	CHECKED	DATE	CHECKED
	RD		CF		CF

DATE	CHECKED	DATE	CHECKED	DATE	CHECKED
	RD		CF		CF

DATE	CHECKED	DATE	CHECKED	DATE	CHECKED
	RD		CF		CF

DATE	CHECKED	DATE	CHECKED	DATE	CHECKED
	RD		CF		CF

DATE	CHECKED	DATE	CHECKED	DATE	CHECKED
	RD		CF		CF

SEE SHT 1	MASS	ORIGINAL SCALE	SIZE	DRAWING NUMBER	SHEET OF	ISSUE
		1:25	A1	700418	8	17 E

TITLE	ASSEMBLY & DETAILS OF SLEW DECK & MAST STRUCTURE
-------	---

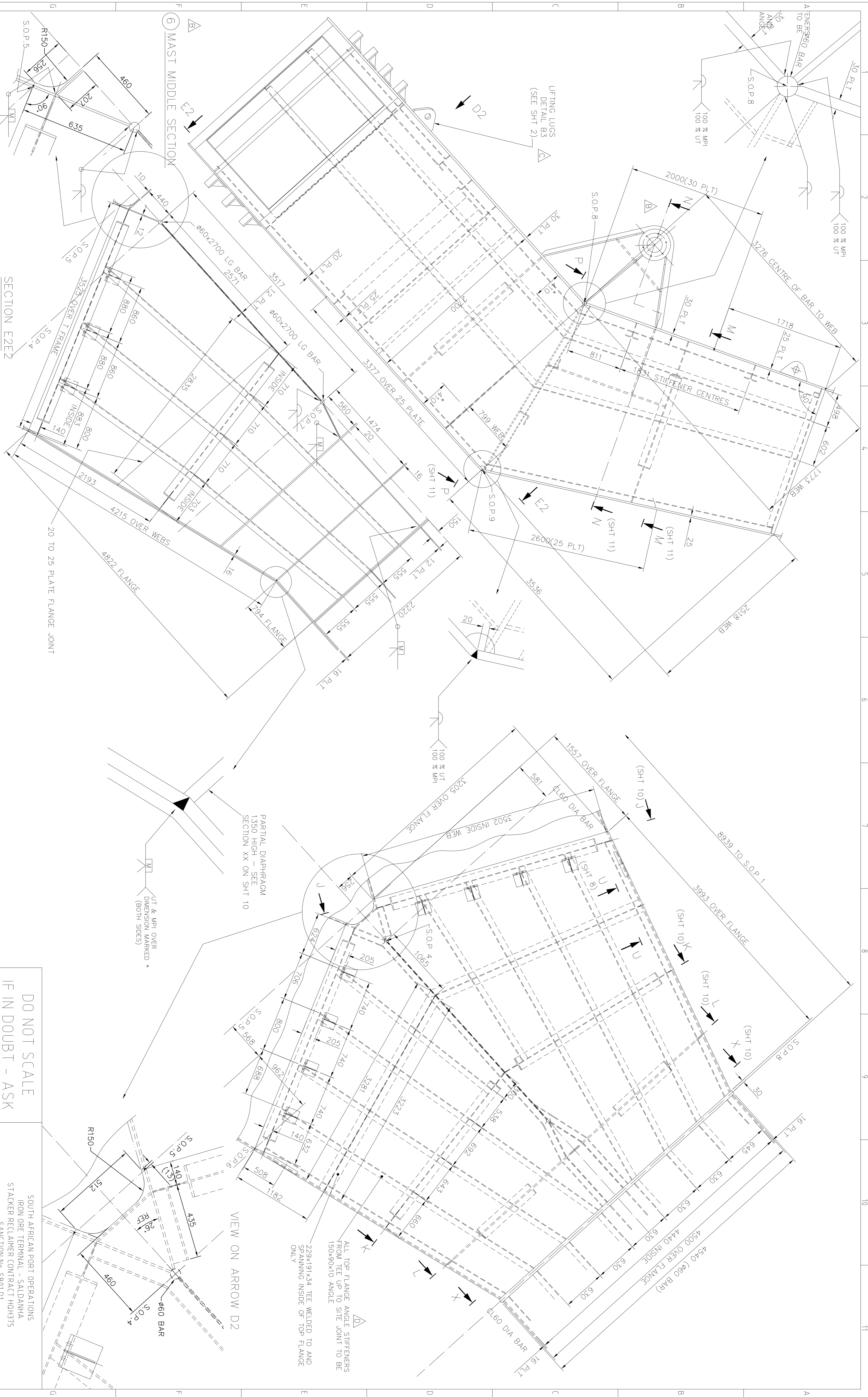

DATE	APPROVED	CHECKED	DATE	APPROVED	CHECKED	DATE	APPROVED	CHECKED	DATE	APPROVED	CHECKED	DATE	APPROVED	CHECKED	DATE	APPROVED	CHECKED	DATE	APPROVED	
16.02.06	DDB	RD	22.6.06	JWH	DWB	CF	DWB	CF	8/10/02	GBL	JWH	15.08.02	FAB	JWH	JWH	16.08.02	USB	NCN	JWH	15.7.02
16.02.06			22.6.06						8/10/02			15.08.02				16.08.02				15.7.02

ISSUES RAISED AS BUILT REFER TO SHEET 2 OF 17 AS BUILT

GENERALLY MODIFIED TO AS BUILT STANDARD NOTE ADDED CLARIFYING EXTENT OF 130 DP. ANGLE STIFF. (GRID E11)

ADDITIONAL INTERFACI INFO. ADDED. SEE SHTS. 14-17. (NO CHANGES ON THIS SHEET)

LUFF CYLINDER CONNECTION REVISI SEE ALSO SHTS 1 TO 8 & 10 TO 13

ISSUED FOR MANUFACTURE

UNLESS OTHERWISE SPECIFIED IDENTIFY THE ITEM WITH THE DRAWING NUMBER AND ISSUE LEVEL AT AND IN THE MANNER SHOWN FOR PAINTING AND FOR LUBRICATION SPECIFICATIONS SEE COMPONENTS LIST

TOLERANCES UNLESS OTHERWISE STATED (PLUS OR MINUS) RANGE MACH FAB CAST

0-500	2	2	2
501-1000	0.25	3	4
1001-2000	0.5	4	6
ABOVE 2000	1.0	6	10

UT & MPI OVER DIMENSION MARKED *

THIS PRINT AND ALL THE INFORMATION HEREON IS THE PROPERTY OF METSO MINERALS. Bulk Materials Handling Bristol and must not be made public, copied or used in any way detrimental to our interests. It is loaned subject to return on demand, unless furnished under contract provisions.

DO NOT SCALE
IF IN DOUBT - ASK

metso minerals

SOUTH AMERICAN PORT OPERATIONS
IRON ORE TERMINAL - SALDANHA
STACKER RECLAIMER CONTRACT HQH375
SANCTION No. SB01D1

METSO MINERALS (UK) LTD
BULK MATERIALS HANDLING BRISTOL
PO BOX 821 ASHTON VALE RD
BRISTOL BS99 5ZB ENGLAND

ASSEMBLY & DETAILS OF
SLEW DECK & MAST STRUCTURE

MASS ORIGINAL SCALE SIZE DRAWING NUMBER SHEET OF ISSUE
SEE SHT 1 1:25.UOS A1 700418 9 17 E

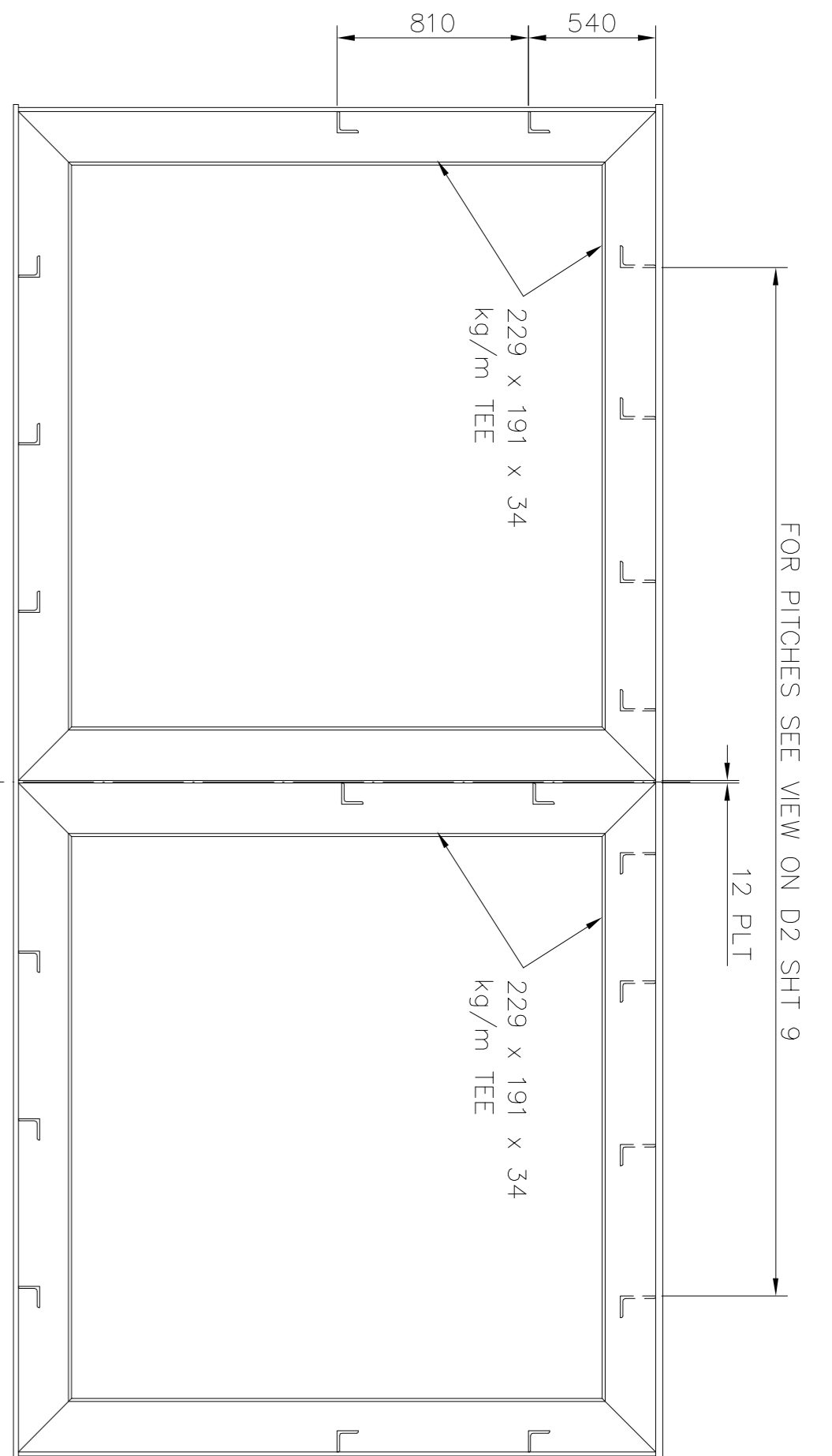
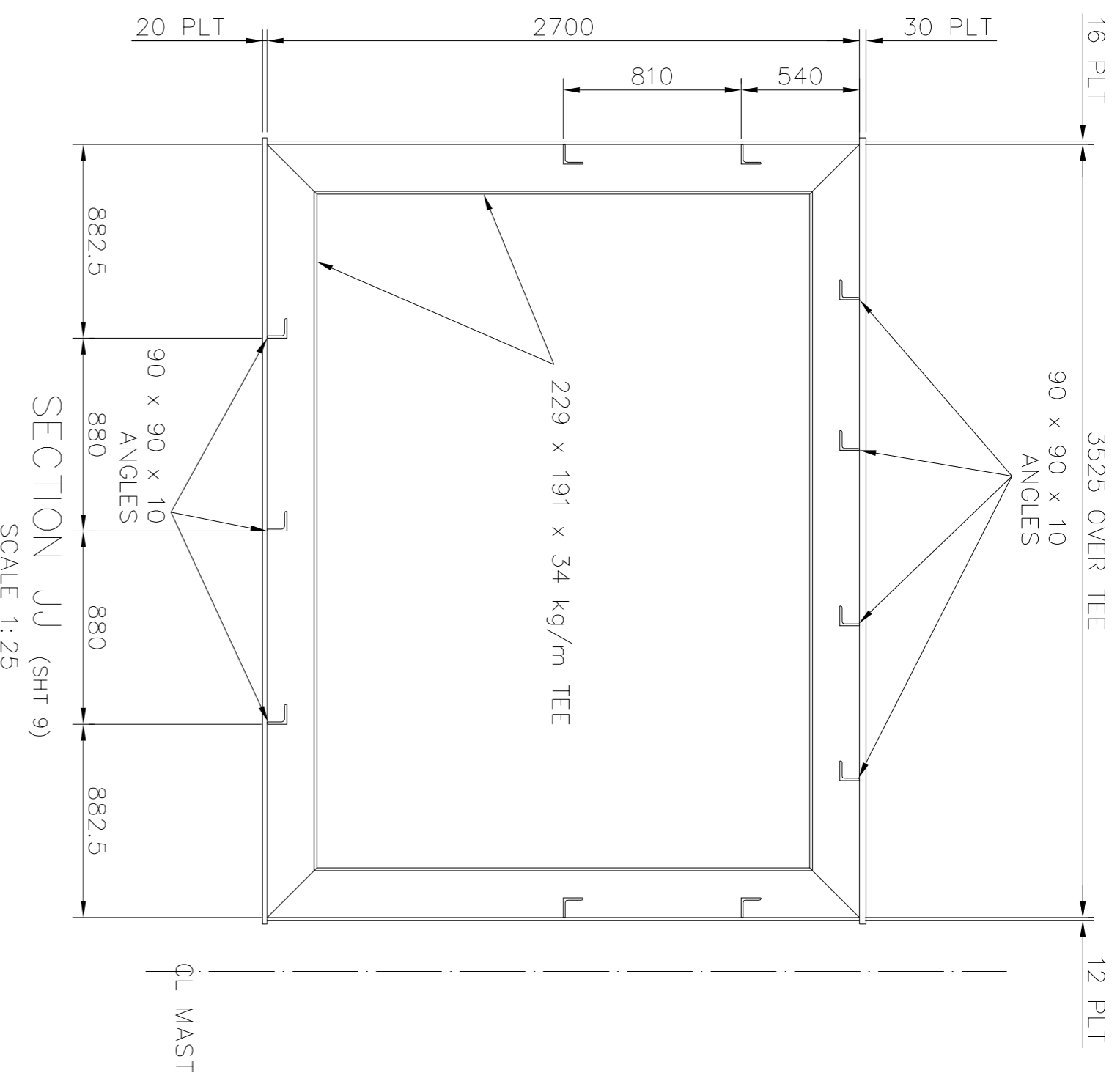

SECTION KK (SHT 9)
SCALE 1:25

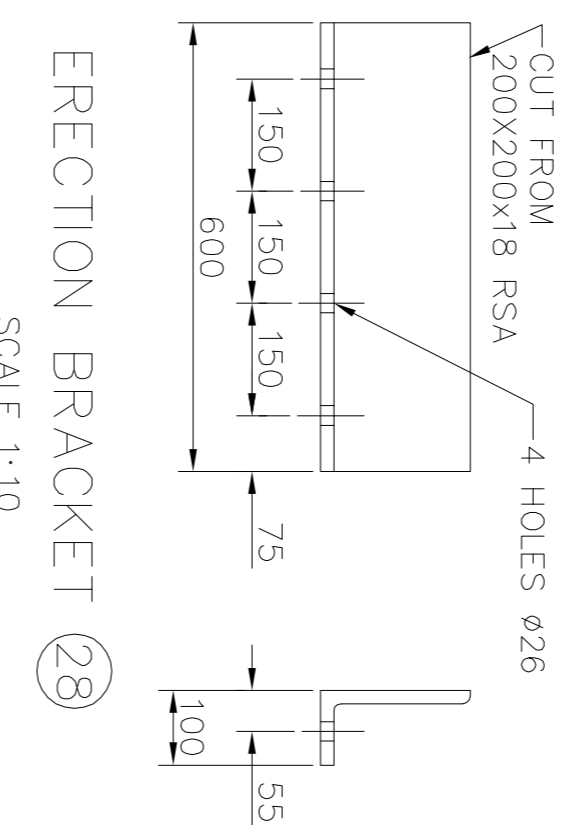
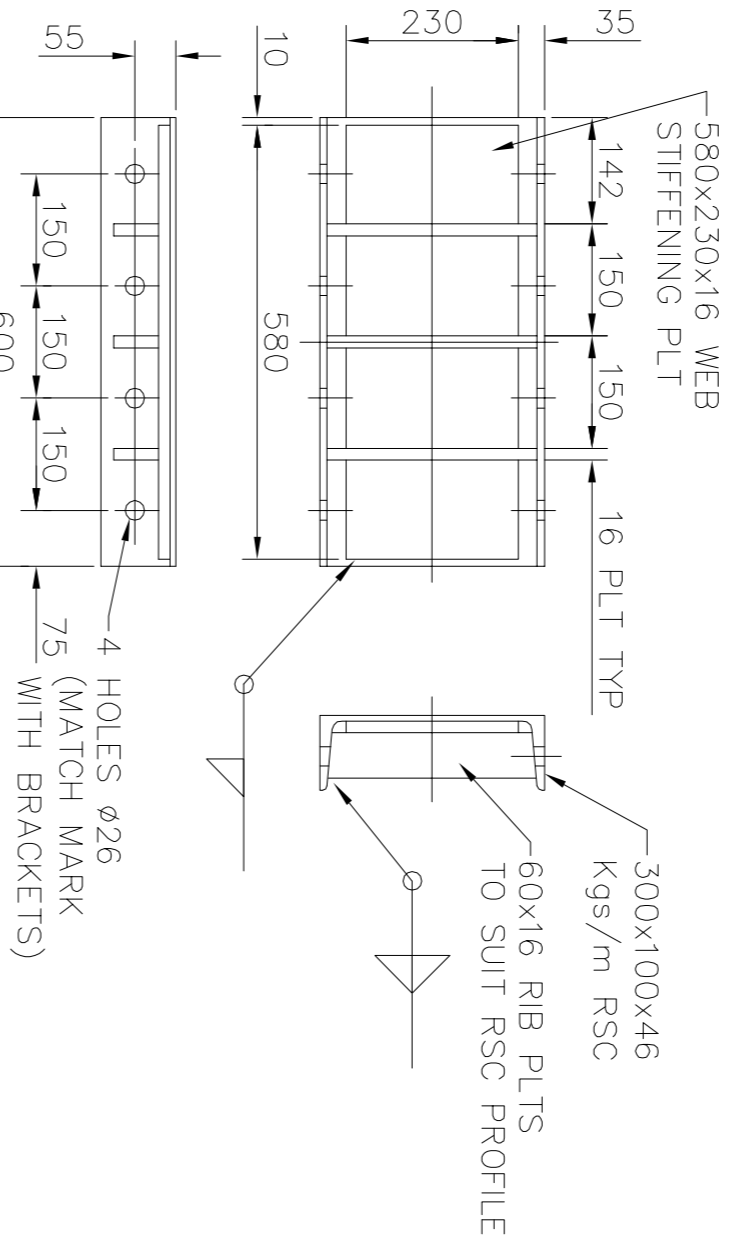

PACKING SET (27)
SCALE 1:10

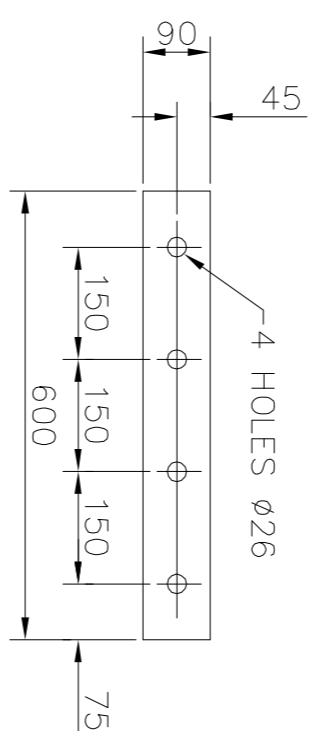

WEB SITE JOINT SPACER (26)
SCALE 1:10

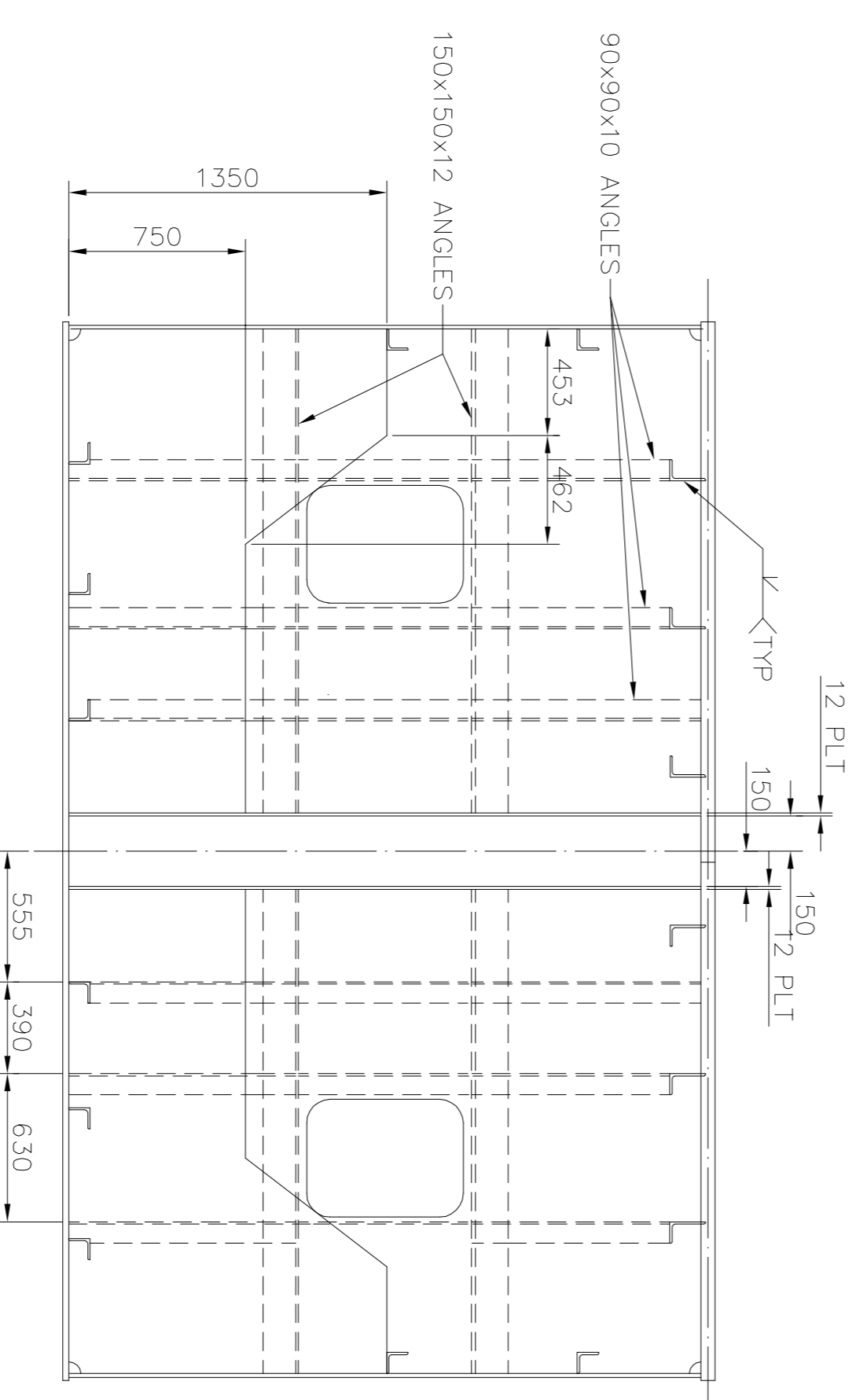
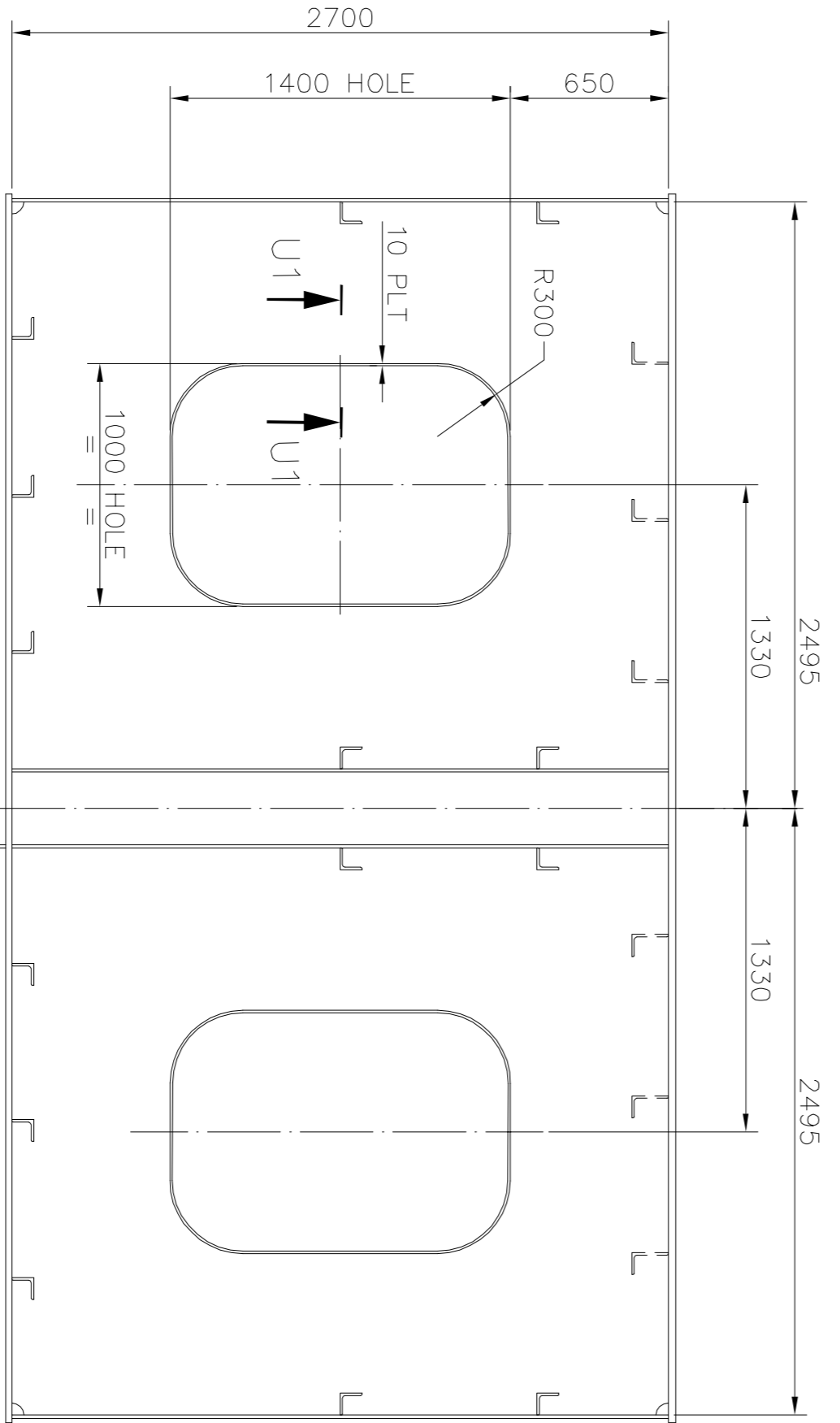
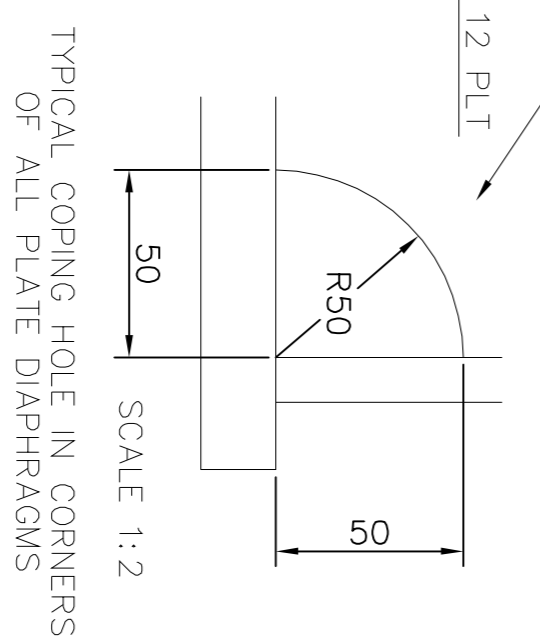
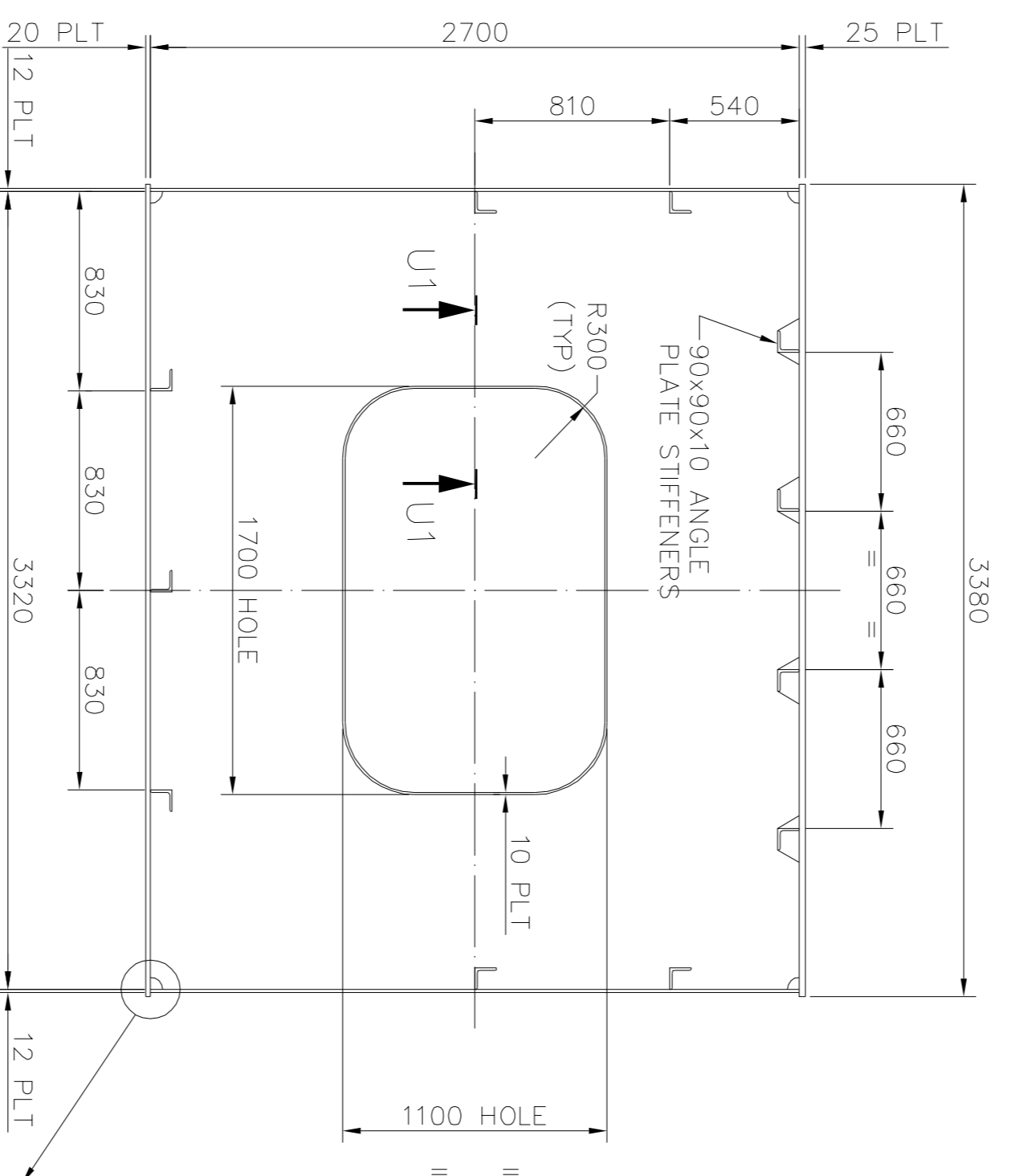
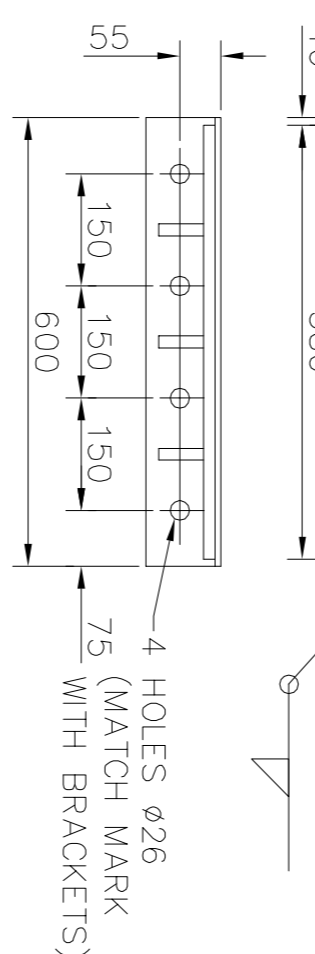

SECTION UU1
SCALE 1:5

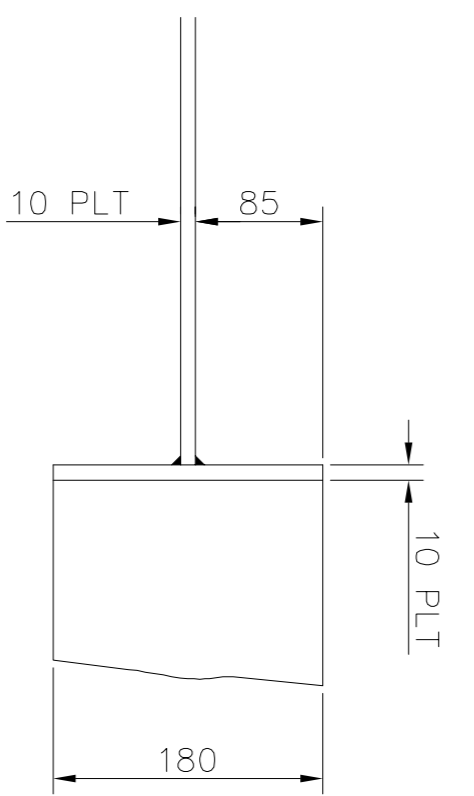

SECTION LL (SHT 9)
SCALE 1:25

SECTION XX (SHT 9)
SCALE 1:25

ISSUES RAISED REFER TO SHEET 2 OF 17 AS BUILT

GENERALLY MODIFIED TO AS BUILT STANDARD (NO CHANGES ON THIS SHEET)

INCORRECT REF. TO SHT: 9 DELETED (GND FS), ADDITIONAL INTERFACE INFO. ADDED. SEE SHT. 14-17.

SEE SHTS 1 TO 9 & 11 TO 13

ISSUED FOR MANUFACTURE

DATE	APPROVED	DATE	APPROVED	DATE	APPROVED	DATE	APPROVED	DATE	APPROVED	DATE	APPROVED	DATE	APPROVED	DATE	APPROVED	DATE	APPROVED
16/02/06	DDB	22/6/06	RD	22/6/06	JWH	DEC 04	DWB	JAN 05	CF	JAN 05	DWB	8/10/02	CF	18/10/02	GBL	21/10/02	JWH
16/08/02	FAB	16/08/02	JWH	16/08/02	JWH	15/06/02	USB	29/06/02	NCN	15/7/02	JWH						

DO NOT SCALE
IF IN DOUBT - ASK

metso minerals

SOUTH AFRICAN PORT OPERATIONS
IRON ORE TERMINAL - SALDANHA
STACKER RECLAIMER CONTRACT HQH375
SANCTION No. SB01 D1

METSO MINERALS (UK) LTD
BULK MATERIALS HANDLING BRISTOL
PO BOX 821 ASHTON VALE RD
BRISTOL BS99 5ZB ENGLAND

ASSEMBLY & DETAILS OF
SLEW DECK & MAST STRUCTURE

MASS SEE SHT 1 ORIGINAL SCALE 1:25, UOS SIZE DRAWING NUMBER A1 SHEET OF 10 ISSUE 17

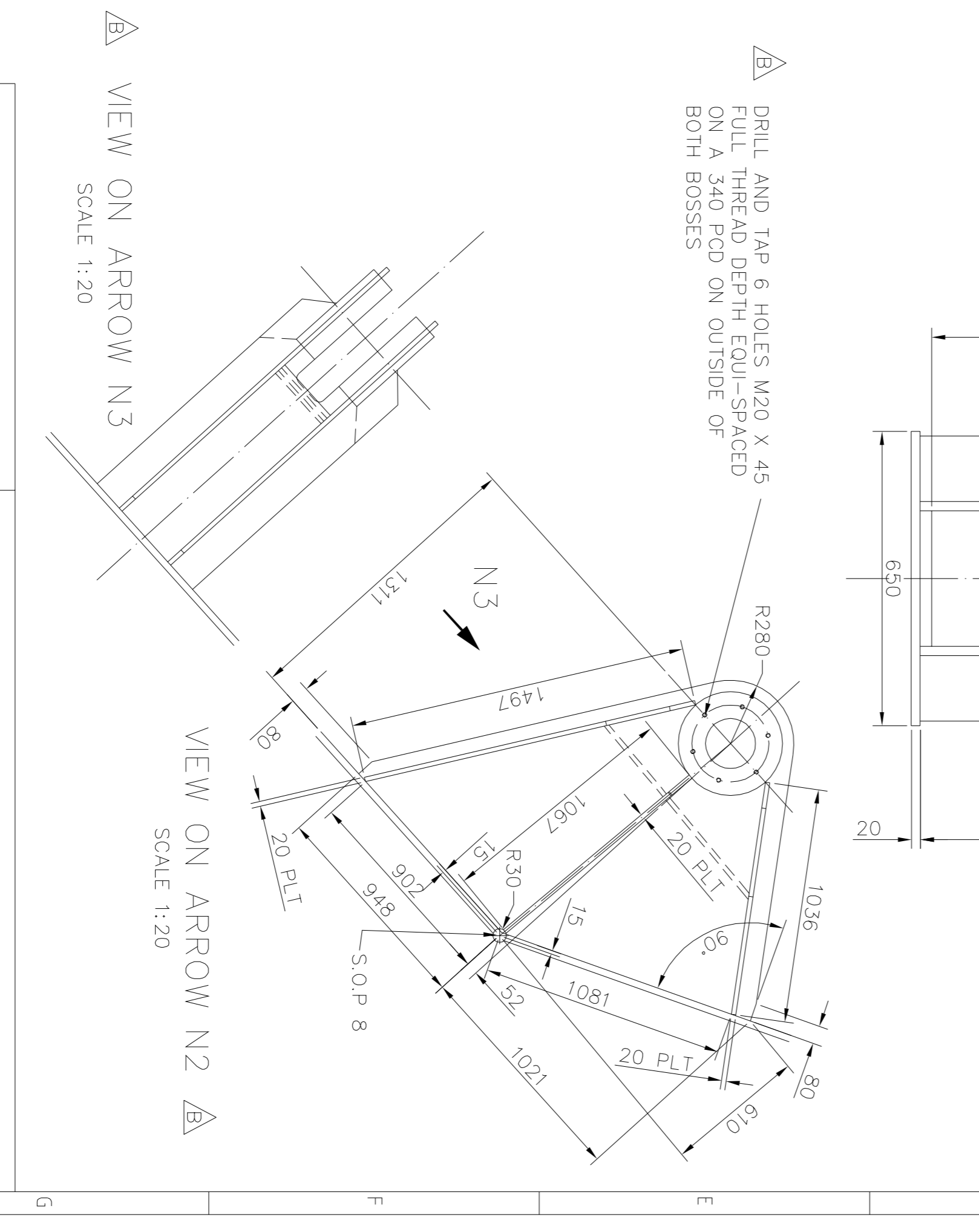
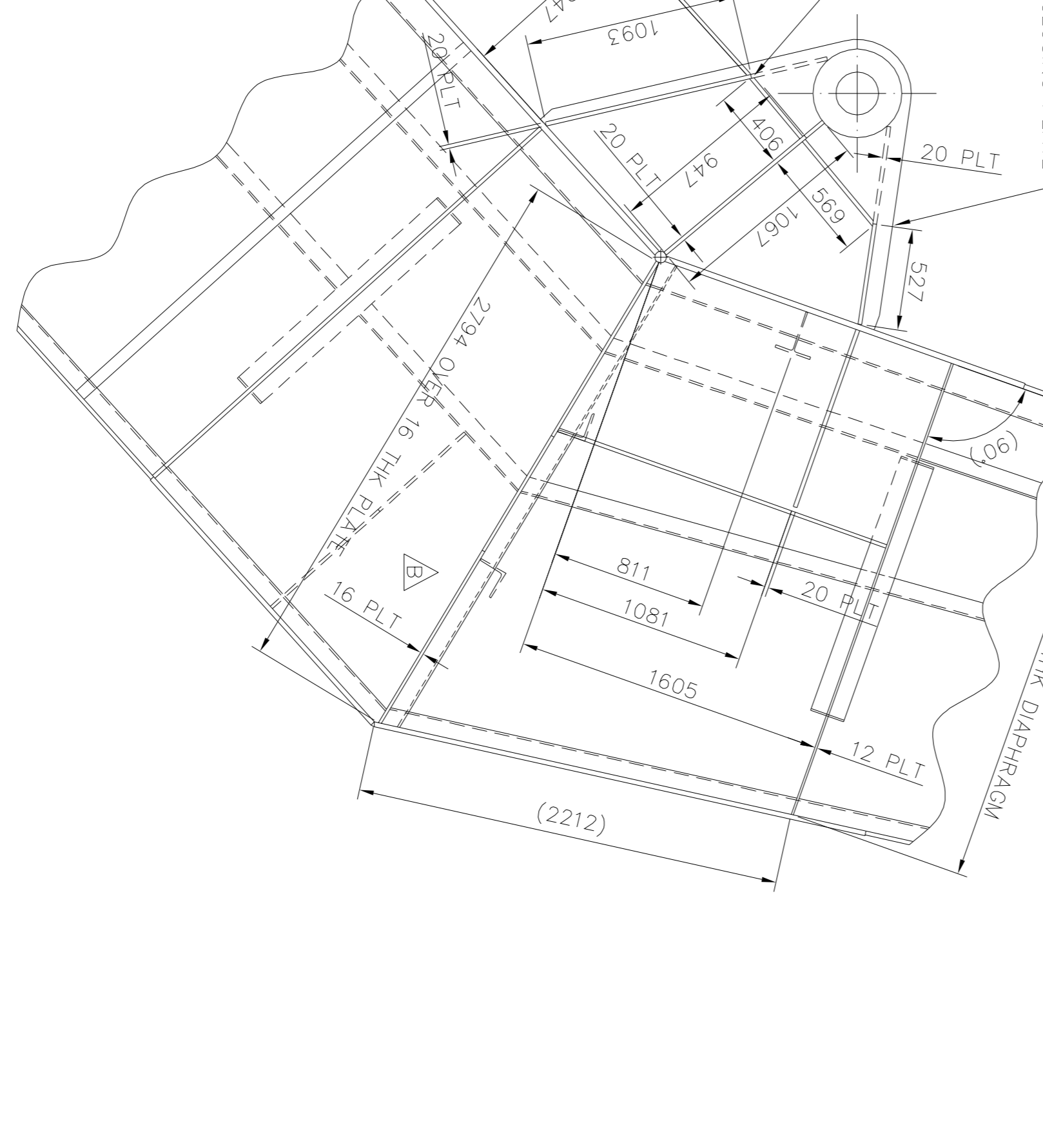
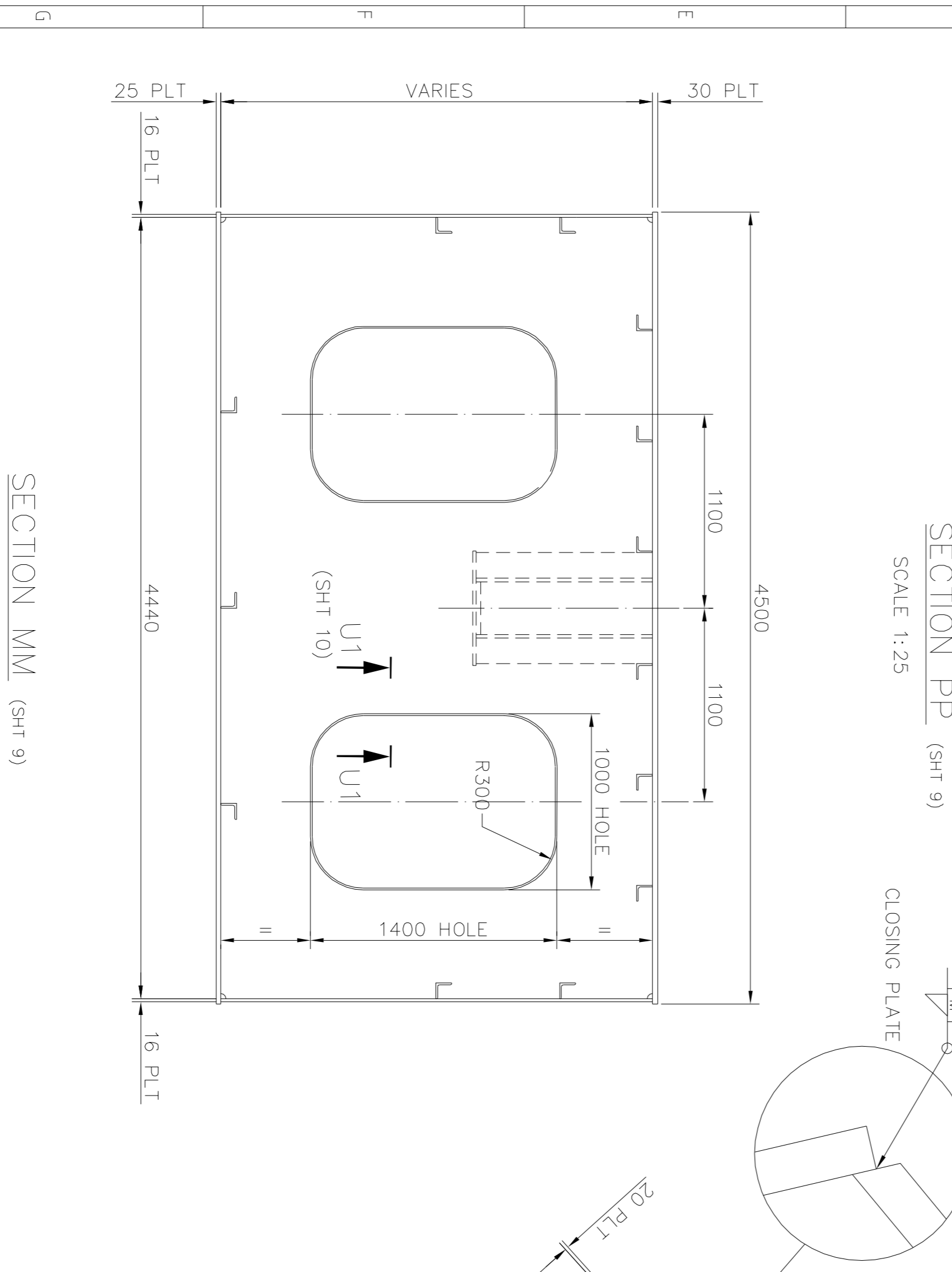
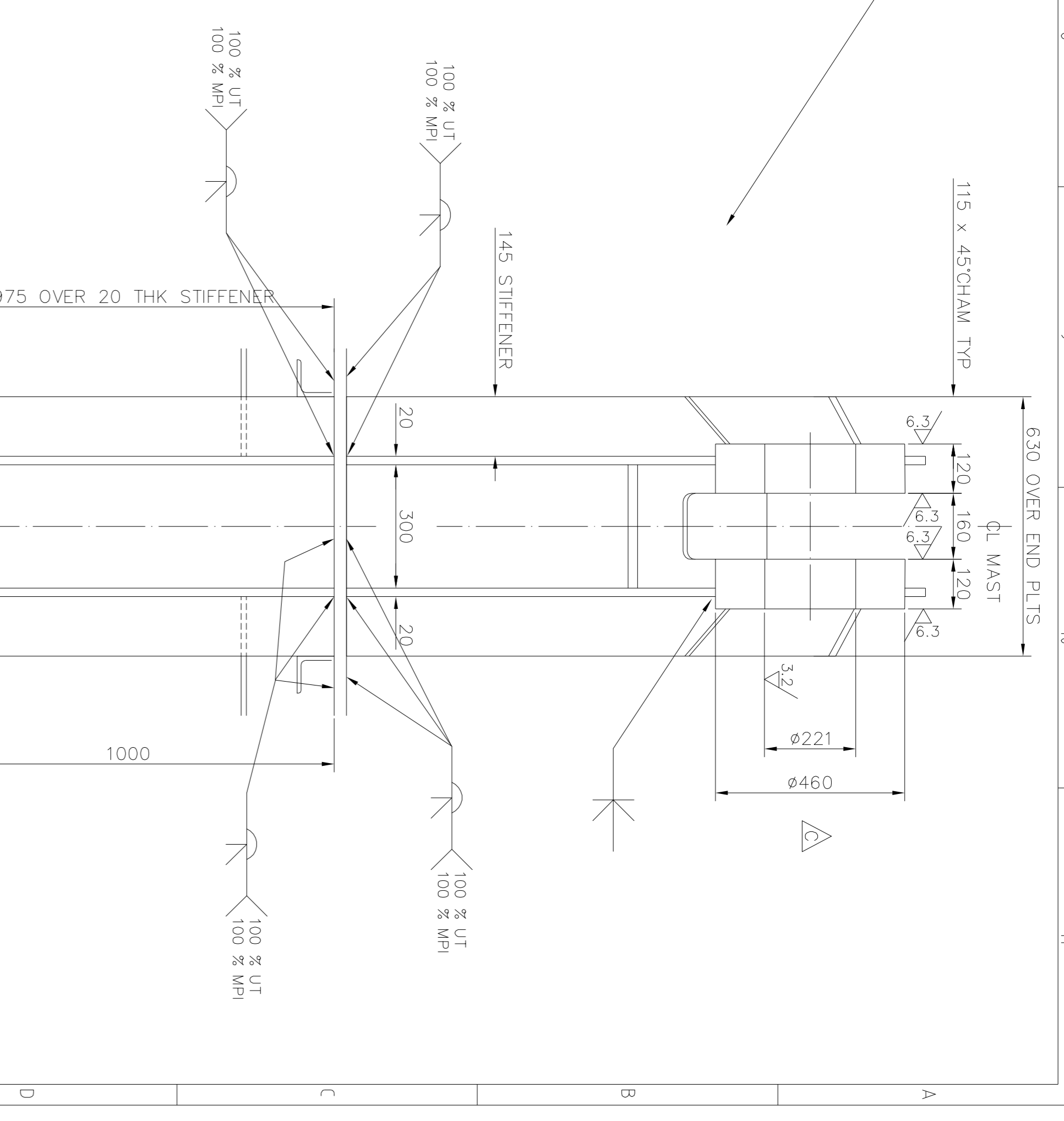
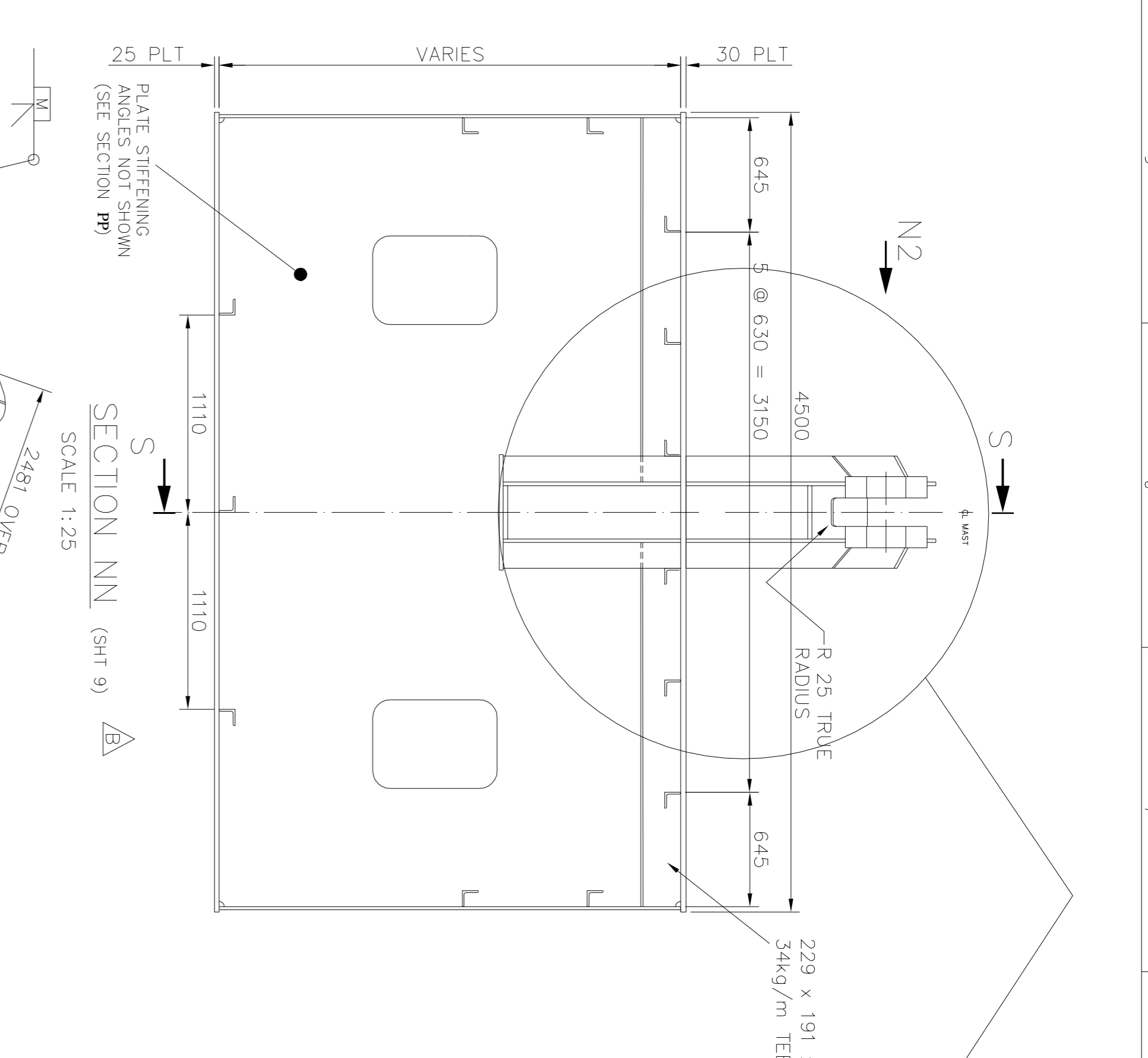
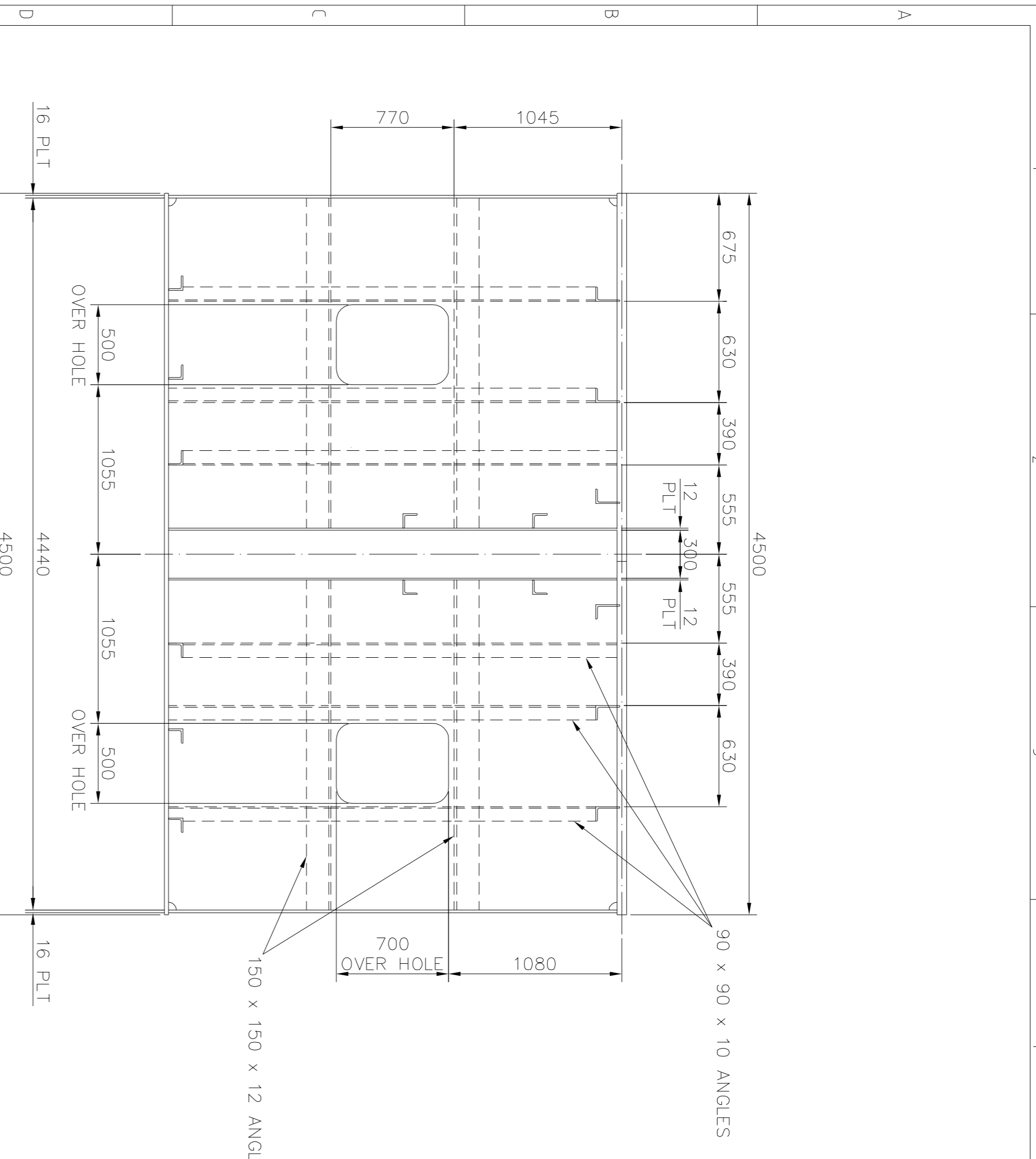

SECTION MM (SHT 9)
SCALE 1:25

SECTION NN (SHT 9)
SCALE 1:25

SECTION PP (SHT 9)
SCALE 1:25

SECTION SS (SHT 9)
SCALE 1:25

DATE	APPROVED	DATE	APPROVED	DATE	APPROVED	DATE	APPROVED	DATE	APPROVED	DATE	APPROVED
16/02/06	DDB	22/6/06	RD	22/6/06	JWH	DEC/04	DWB	8/10/02	CF	21/10/02	JWH
16/02/06	DDB	22/6/06	RD	22/6/06	JWH	DEC/04	DWB	8/10/02	CF	21/10/02	JWH
16/02/06	DDB	22/6/06	RD	22/6/06	JWH	DEC/04	DWB	8/10/02	CF	21/10/02	JWH
16/02/06	DDB	22/6/06	RD	22/6/06	JWH	DEC/04	DWB	8/10/02	CF	21/10/02	JWH
16/02/06	DDB	22/6/06	RD	22/6/06	JWH	DEC/04	DWB	8/10/02	CF	21/10/02	JWH

ISSUES RAISED AS BUILT REFER TO SHEET 2 OF 17 AS BUILT

GENERALLY MODIFIED TO AS BUILT STANDARD WELD DETAILS (CLARIFIED ON ENLARGED DETAIL (GRD 08/C11) SECTION S-S PICTORIALY CORRECTED.

BOSS DIA ADDED (GRID A11) ADDITIONAL INTERFAC INFO. ADDED. SEE SHTS. 14-17

RET. SECTION NN,SS VIEW ON ARROW N3 AND N2 LEFT CYLINDER CONNECTION REWORKED REUSED RET. GRID OF DIAPHRAGM THICKNESS ADDED SEE ALSO SHTS 1 TO 10 & 12 AND 13

UNLESS OTHERWISE SPECIFIED IDENTIFY THE ITEM WITH THE DRAWING NUMBER AND ISSUE LEVEL AT AND IN THE MANNER SHOWN FOR PAINTING AND FOR LUBRICATION SPECIFICATIONS SEE COMPONENTS LIST

UNLESS OTHERWISE STATED DIMENSIONS ARE IN MILLIMETRES TOLERANCES UNLESS OTHERWISE STATED (PLUS OR MINUS)

RANGE	MACH	FAB	CAST
0-500	0.25	2	2
501-1000	0.5	3	4
1001-2000	1.0	4	6
ABOVE 2000	2.0	6	10

This print and all the information hereon is the property of Metso Minerals. Bulk Materials Handling Bristol and must not be made public, copied or used in any way detrimental to our interest. It is loaned subject to return on demand, unless furnished under contract provisions

DO NOT SCALE
IF IN DOUBT - ASK

metso minerals

SOUTH AFRICAN PORT OPERATIONS
IRON ORE TERMINAL - SALDANHA
STACKER RECLAIMER CONTRACT HQH375
SANCTION NO. SB01D1

METSO MINERALS (UK) LTD
BULK MATERIALS HANDLING BRISTOL
PO BOX 821 ASHTON VALE RD
BRISTOL BS99 5ZB ENGLAND

ASSEMBLY & DETAILS OF
SLEW DECK & MAST STRUCTURE

ORIGINAL SCALE 1:25, UOS
DRAWING NUMBER 700418
SHEET 11 OF 17
ISSUE E

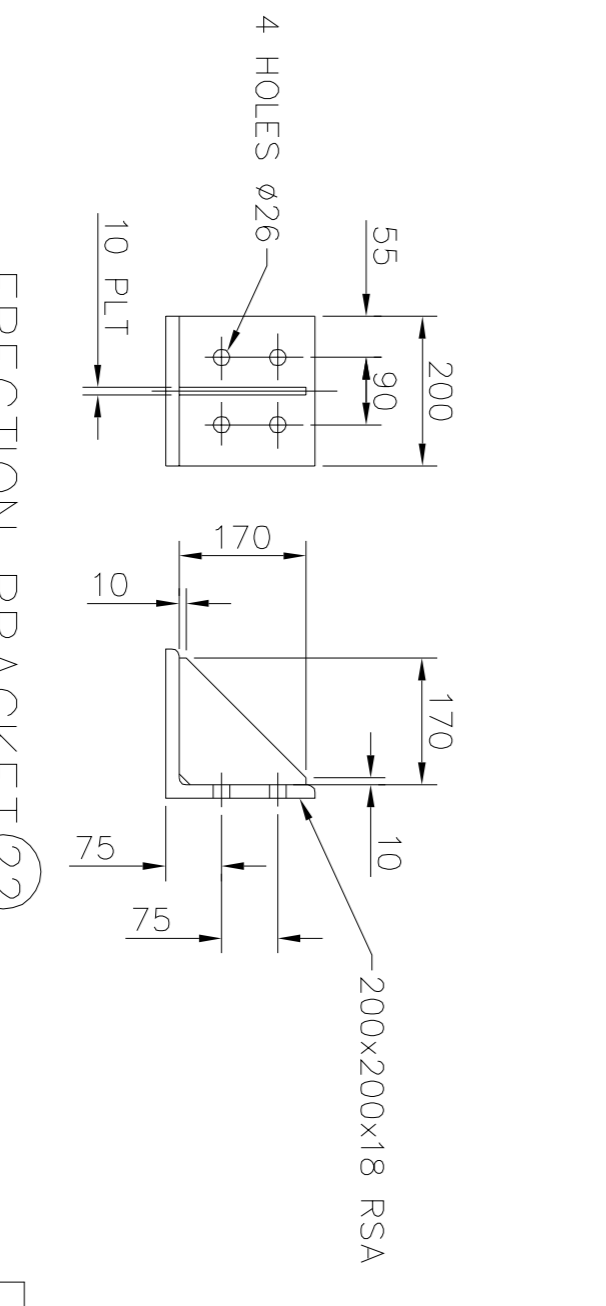
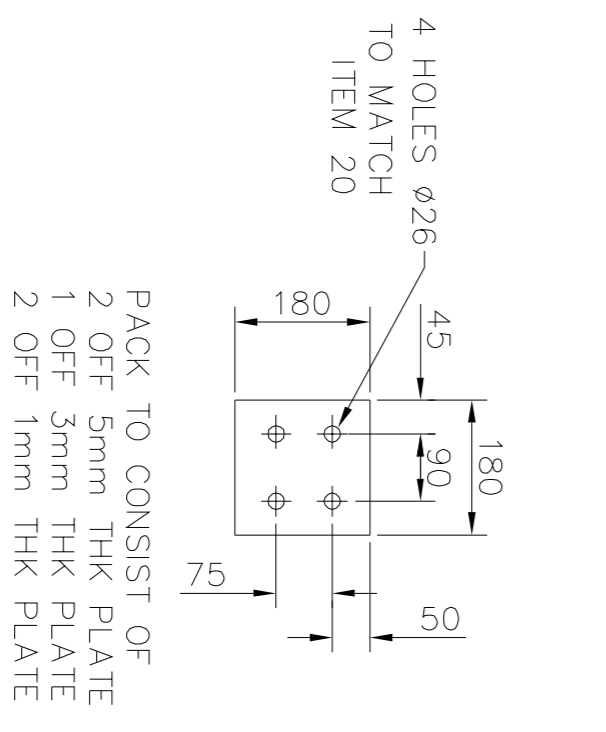
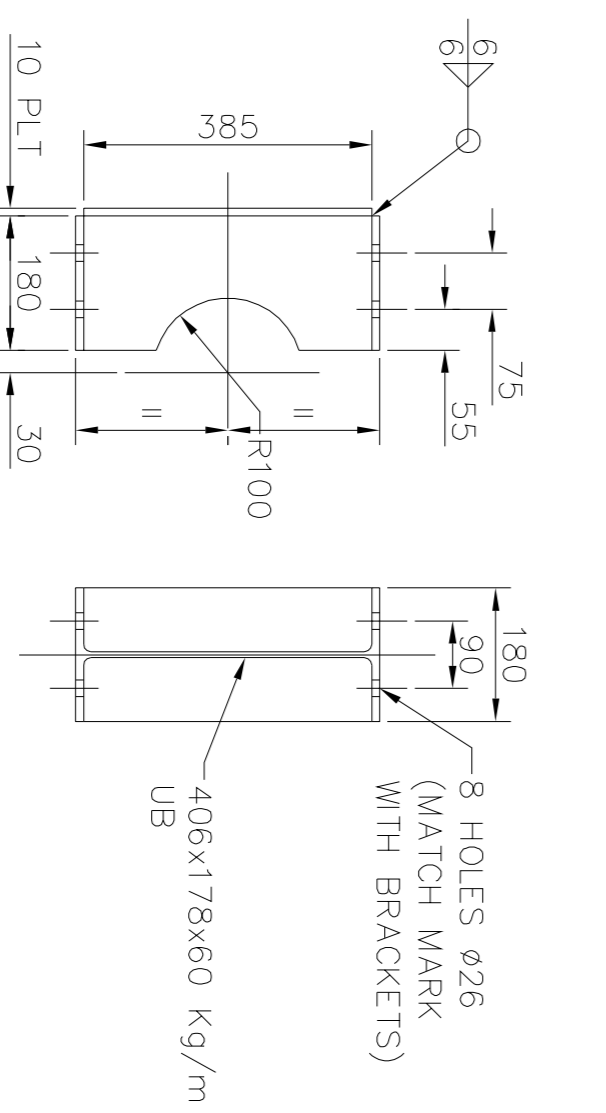
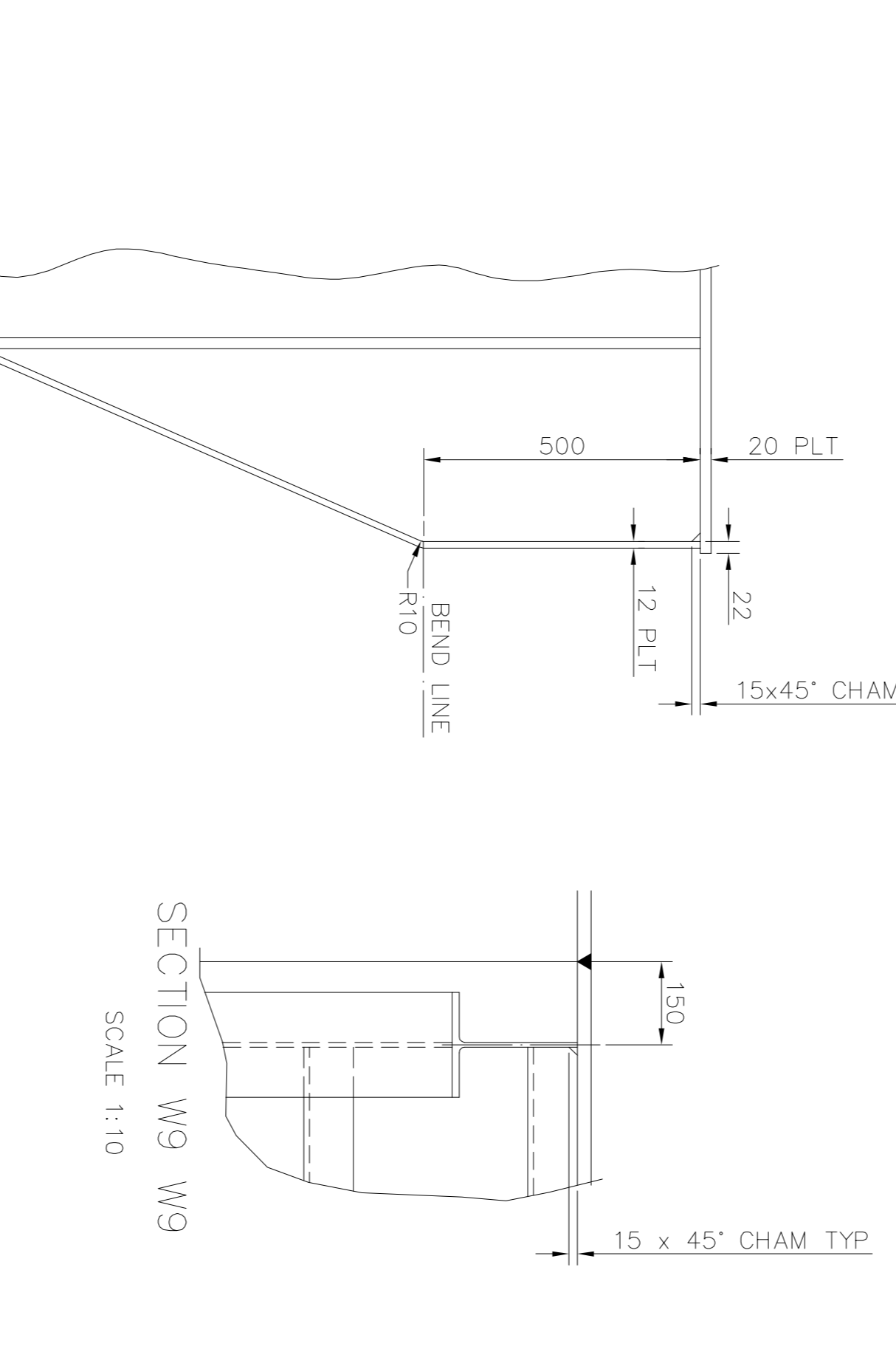
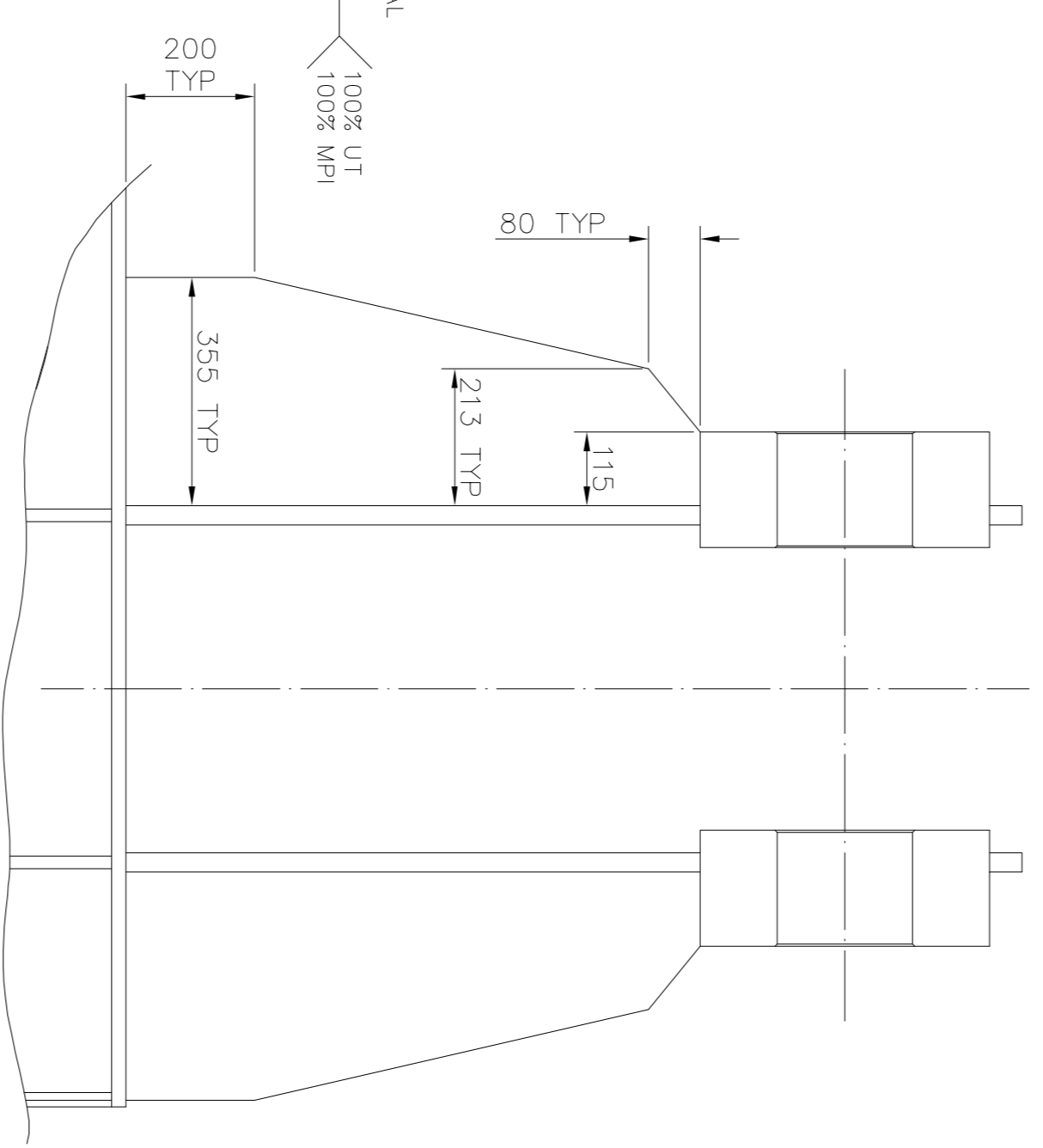
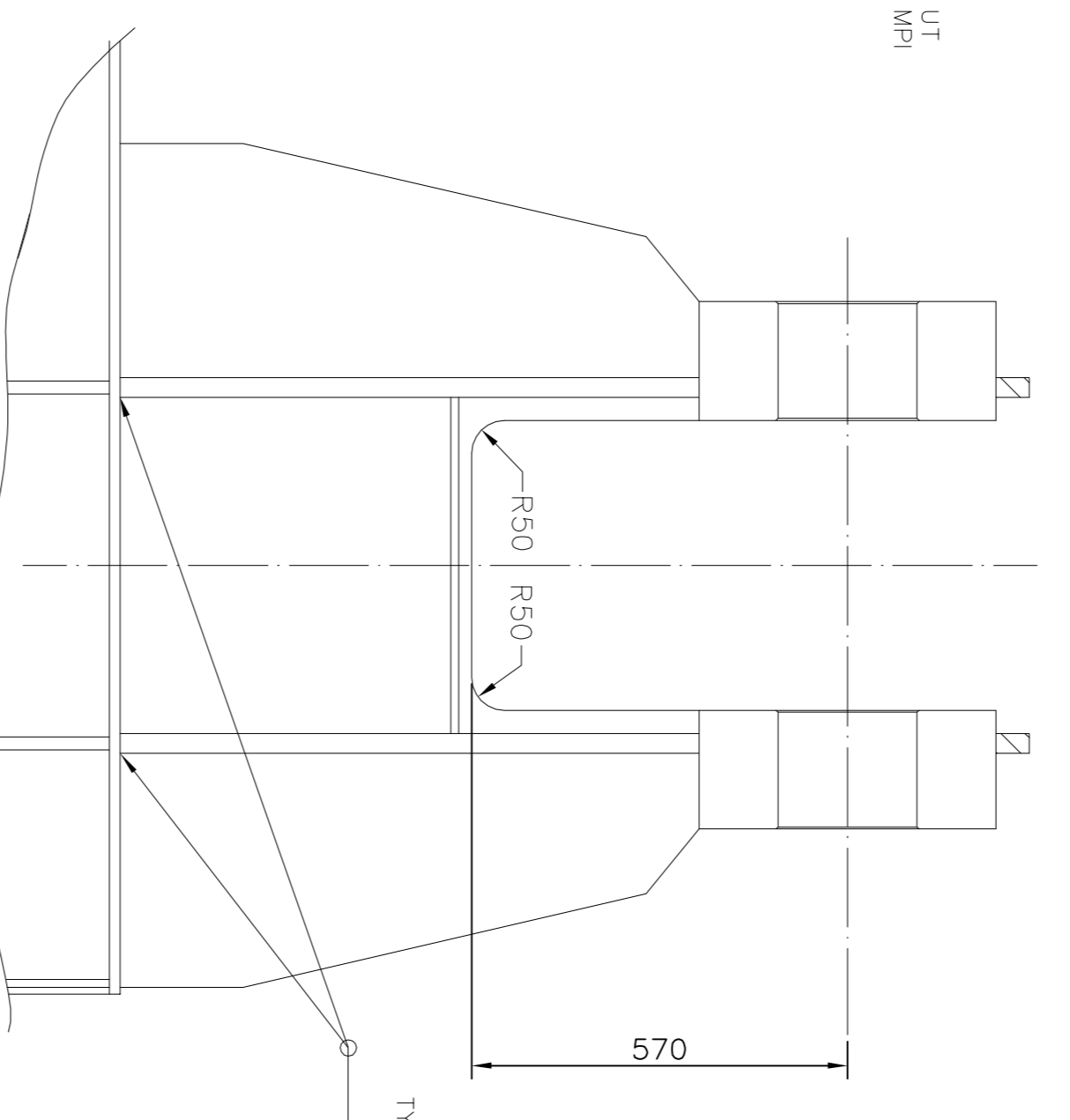
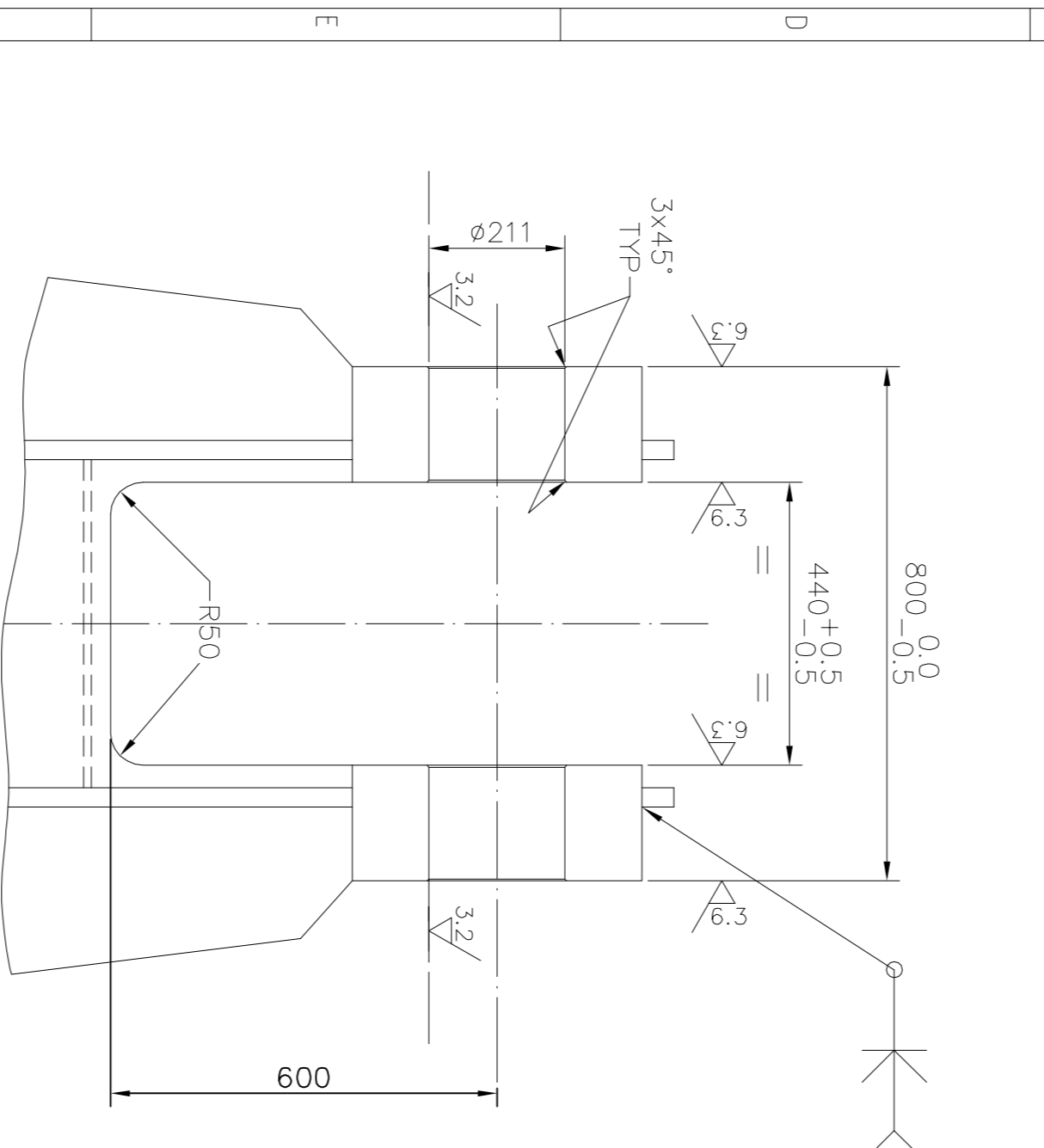
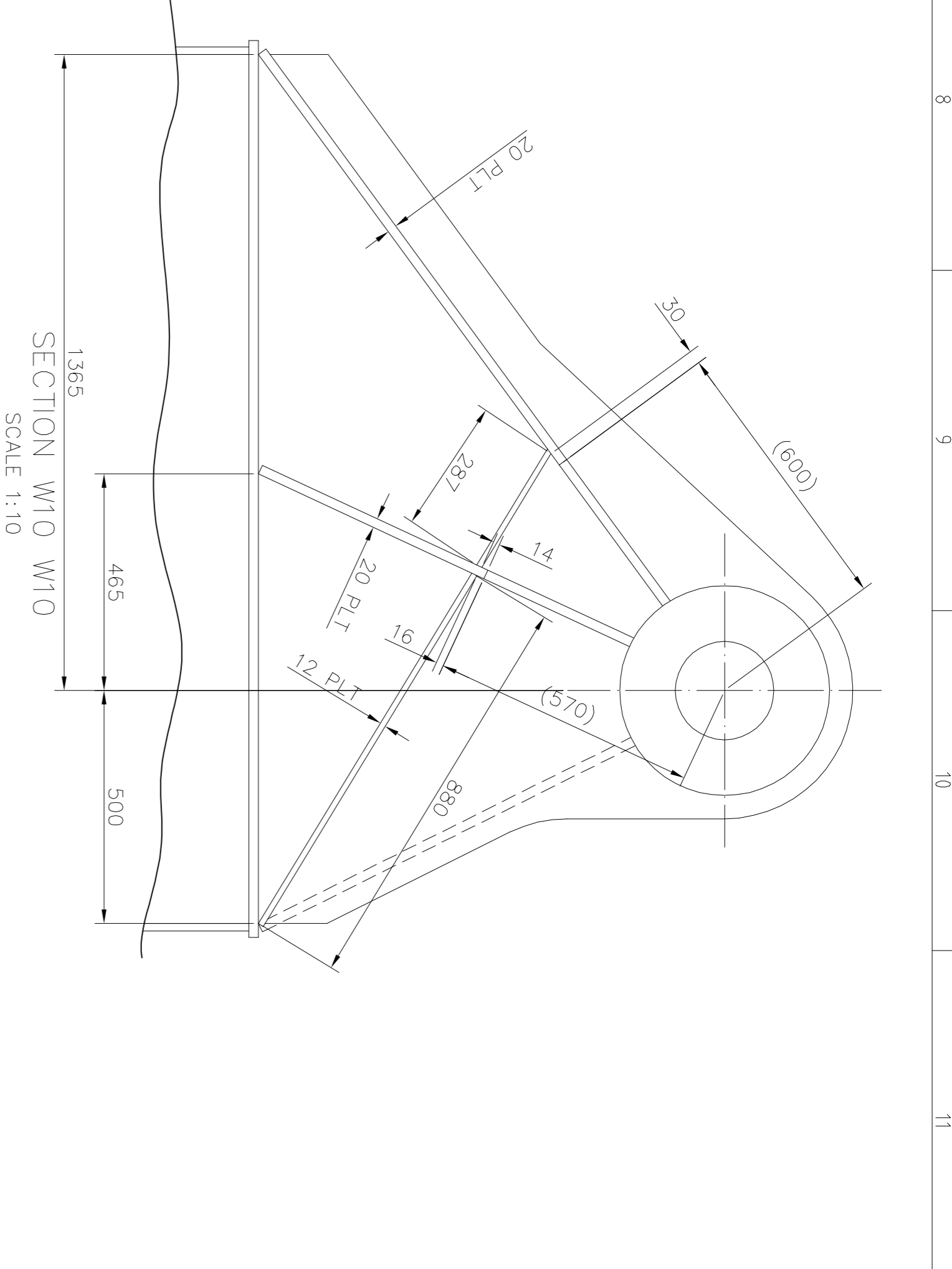
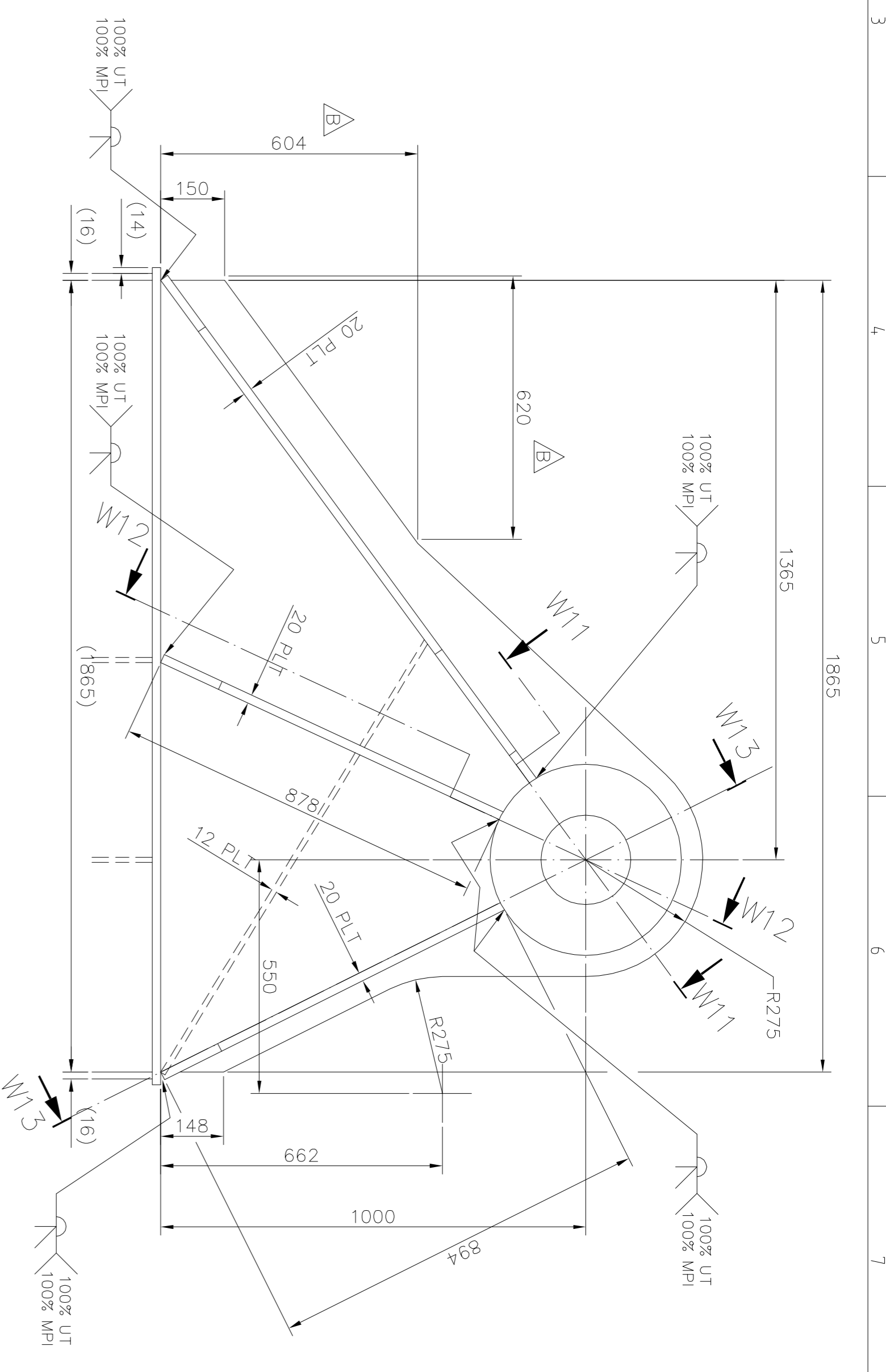
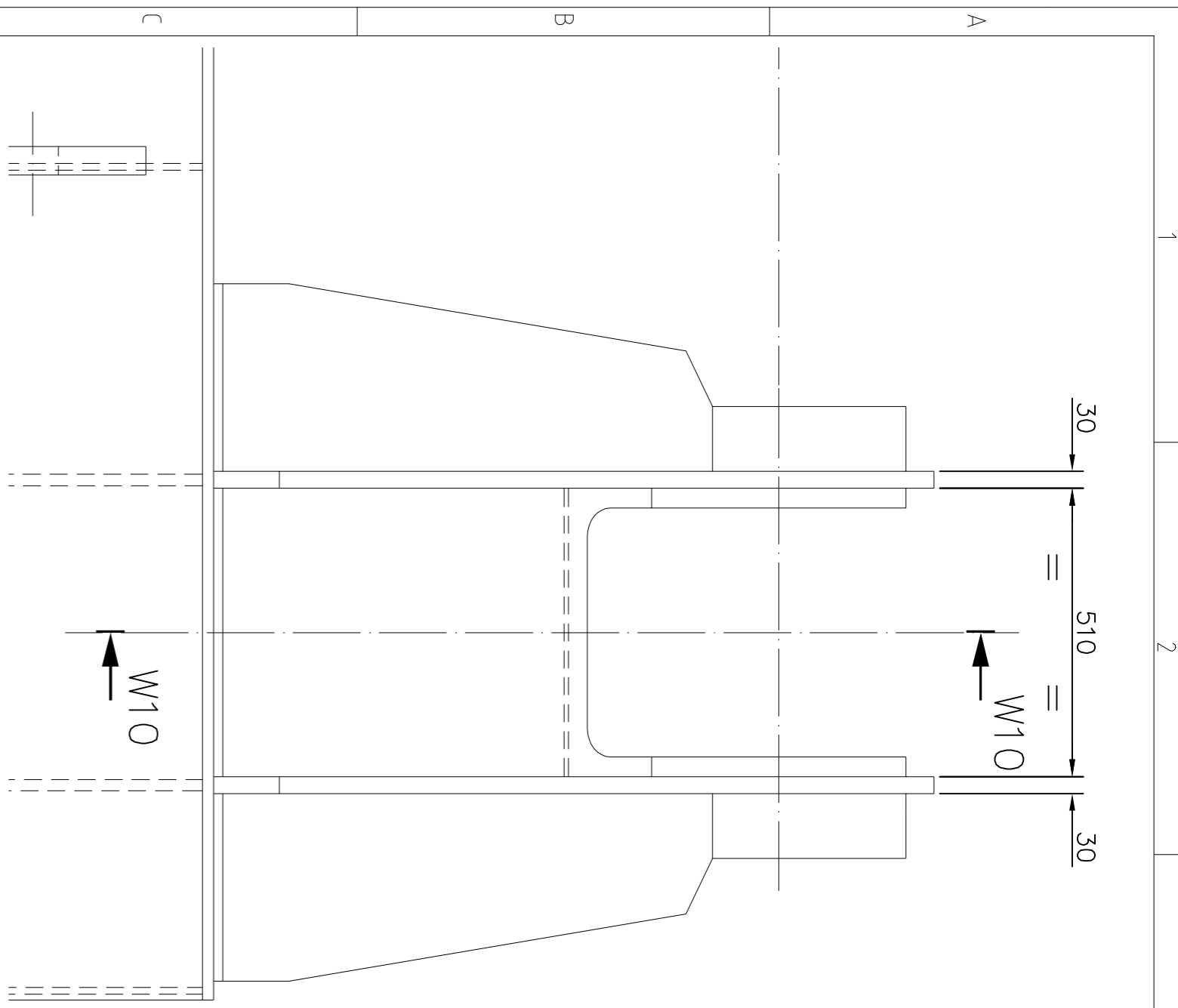

FLANGE SITE JOINT SPACER **(20)**
SCALE 1:10

PACKING SET **(21)**
SCALE 1:10

ERECTOR BRACKET **(22)**
SCALE 1:10

DO NOT SCALE
IF IN DOUBT - ASK

SOUTH AFRICAN PORT OPERATIONS
IRON ORE TERMINAL - SALDANHA
STACKER RECLAIMER CONTRACT HQH375
SANCTION No. SB01D1

metso minerals

METSO MINERALS (UK) LTD
BUICK MATERIALS HANDLING BRISTOL
PO BOX 821 ASHTON VALE RD
BRISTOL BS39 5ZB ENGLAND

ISSUES RAISED REFER TO SHEET 2 OF 17 AS BUILT

GENERALLY MODIFIED TO AS BUILT STANDARD WELD DETAILS ADDED ON MAIN ELEVATION

ADDITIONAL INTERFACIAL INFO. ADDED. SEE SHTS. 14-17 (NO CHANGES ON THIS SHEET)

THIS PRINT AND ALL THE INFORMATION HEREON IS THE PROPERTY OF METSO MINERALS. Bulk Materials Handling Bristol is our interest. It is loaned subject to return on demand unless furnished under contract provisions.

DATE	DATE	DATE	DATE	DATE	DATE	DATE	DATE	DATE	DATE	DATE	DATE	DATE	DATE	DATE	DATE
16.02.06	22.6.06	22.6.06	16.02.06	22.6.06	22.6.06	16.02.06	22.6.06	22.6.06	16.02.06	22.6.06	22.6.06	16.02.06	22.6.06	22.6.06	16.02.06
DDB	RD	JWH	DWB	JWH	JWH	JWH	JWH	JWH	JWH	JWH	JWH	JWH	JWH	JWH	JWH
16.02.06	22.6.06	22.6.06	16.02.06	22.6.06	22.6.06	16.02.06	22.6.06	22.6.06	16.02.06	22.6.06	22.6.06	16.02.06	22.6.06	22.6.06	16.02.06
1	2	3	4	5	6	7	8	9	10	11	12	13	14	15	16

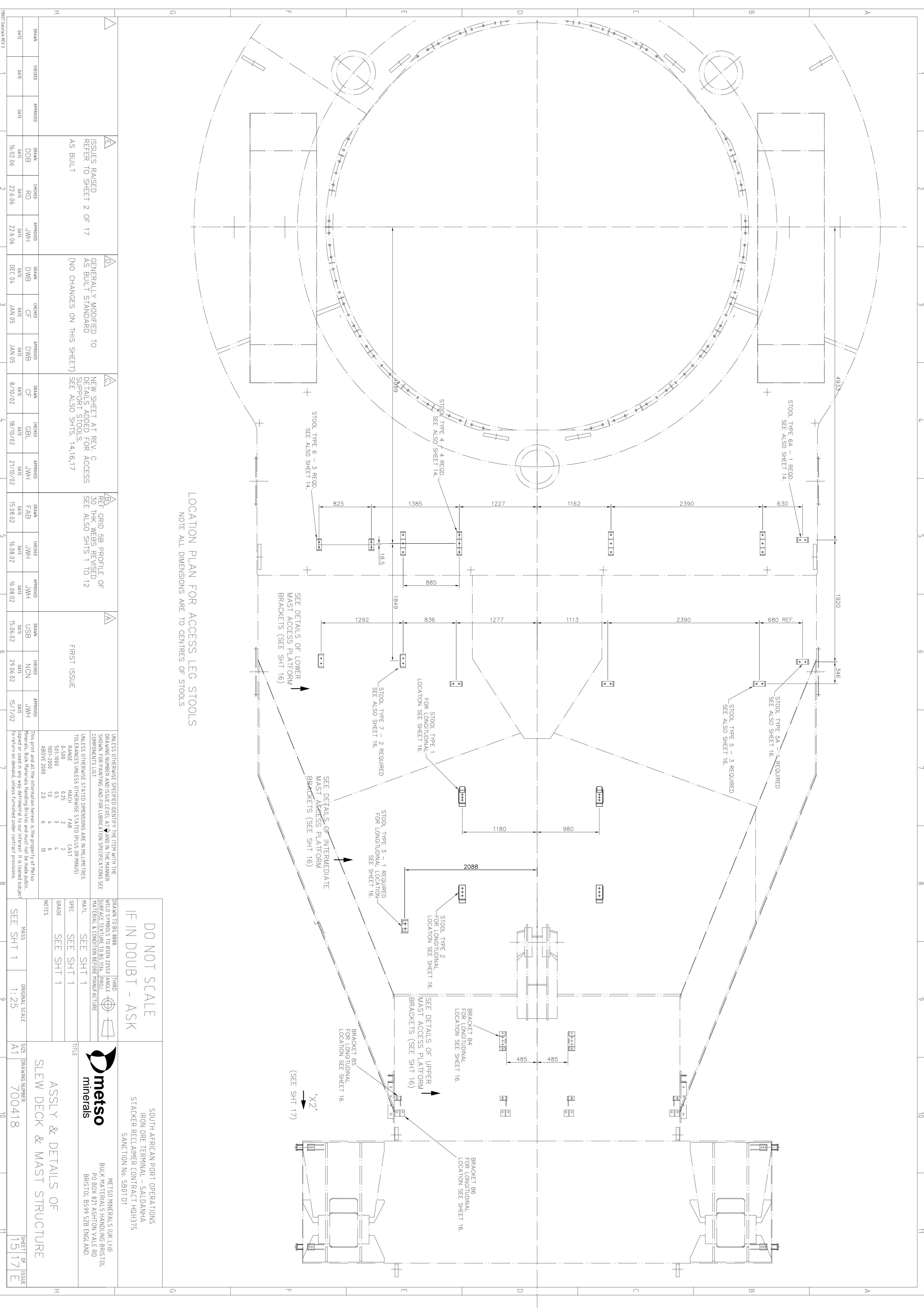

LOCATION PLAN FOR ACCESS LEG STOOLS

NOTE ALL DIMENSIONS ARE TO CENTRES OF STOOLS

DRAWN	DATE	16.02.06	CHECKED	DATE	22.6.06	APPROVED	DATE	22.6.06
	DATE	16.02.06		DATE	22.6.06		DATE	22.6.06
DRAWN	DATE	16.02.06	CHECKED	DATE	22.6.06	APPROVED	DATE	22.6.06
	DATE	16.02.06		DATE	22.6.06		DATE	22.6.06

ISSUES RAISED REFER TO SHEET 2 OF 17 AS BUILT

DRAWN	DATE	DEC 04	CHECKED	DATE	JAN 05	APPROVED	DATE	JAN 05
	DATE	DEC 04		DATE	JAN 05		DATE	JAN 05

GENERALLY MODIFIED TO AS BUILT STANDARD (NO CHANGES ON THIS SHEET)

DRAWN	DATE	8/10/02	CHECKED	DATE	18/10/02	APPROVED	DATE	21/10/02
	DATE	8/10/02		DATE	18/10/02		DATE	21/10/02

NEW SHEET AT REV. C DETAILS ADDED FOR ACCESS SUPPORT STOOLS. SEE ALSO SHITS: 14,16,17

DRAWN	DATE	15.08.02	CHECKED	DATE	16.08.02	APPROVED	DATE	16.08.02
	DATE	15.08.02		DATE	16.08.02		DATE	16.08.02

RET. GRID SB PROFILE OF 30 THK WEBS REVISED SEE ALSO SHITS 1 TO 12

DRAWN	DATE	15.06.02	CHECKED	DATE	29.06.02	APPROVED	DATE	15.7/02
	DATE	15.06.02		DATE	29.06.02		DATE	15.7/02

FIRST ISSUE

UNLESS OTHERWISE SPECIFIED IDENTIFY THE ITEM WITH THE DRAWING NUMBER AND ISSUE LEVEL AT \blacktriangledown AND IN THE MANNER SHOWN FOR PAINTING AND FOR LUBRICATION SPECIFICATIONS SEE COMPONENTS LIST.	
TOLERANCES UNLESS STATED OTHERWISE ARE IN MILLIMETRES	TOLERANCES UNLESS STATED OTHERWISE ARE IN MILLIMETRES RANGE: MACH FAB CAST 0-500 0.25 3 4 501-1000 0.5 3 4 1001-2000 1 4 6 ABOVE 2000 2 6 10
This print and all the information hereon is the property of Metso Minerals. Bulk Materials Handling Bristol and must not be made public, copied or used in any way detrimental to our interest. It is loaned subject to return on demand unless furnished under contract provisions.	
DO NOT SCALE IF IN DOUBT - ASK	THIRD ANGLE
DRAWN TO BS 8888 WELD SYMBOLS TO BS EN 2553 ANGLE SURFACE TEXTURE TO BS EN 1980 MATERIAL & CONDITION BEFORE MANUFACTURE	metso minerals SOUTH AFRICAN PORT OPERATIONS IRON ORE TERMINAL - SALDANHA STACKER RECLAIMER CONTRACT HQH375 SANCTION NO. SB01 D1 METSO MINERALS (UK) LTD BULK MATERIALS HANDLING BRISTOL PO BOX 821 ASHTON VALE RD BRISTOL BS99 5ZB ENGLAND
MASS: SEE SHIT 1 GRADE: SEE SHIT 1 NOTES: SEE SHIT 1	TITLE: ASSEMBLY & DETAILS OF SLEW DECK & MAST STRUCTURE DRAWING NUMBER: 700418 SIZE: A1 ORIGINAL SCALE: 1:25 SHEET OF: 15/17 E

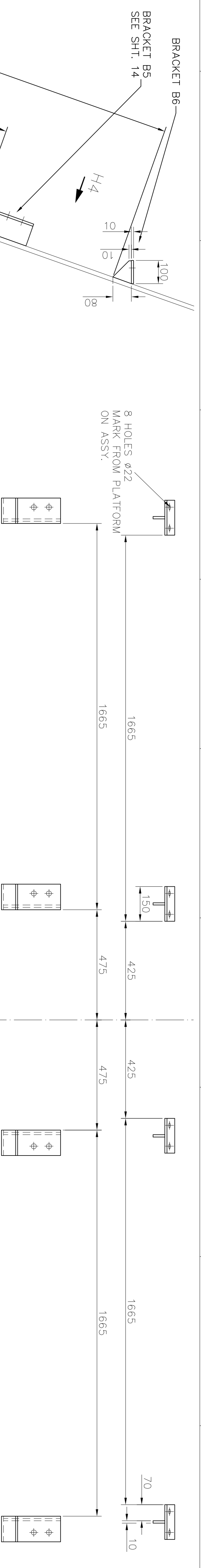

VIEW ON ARROW H4
SCALE - 1:10
NOTE ALL BRACKETS ARE FABRICATED FROM 10 THK. PLATE AND ARE SYMMETRICALLY DISPOSED ABOUT C/L SLEW AS SHOWN.

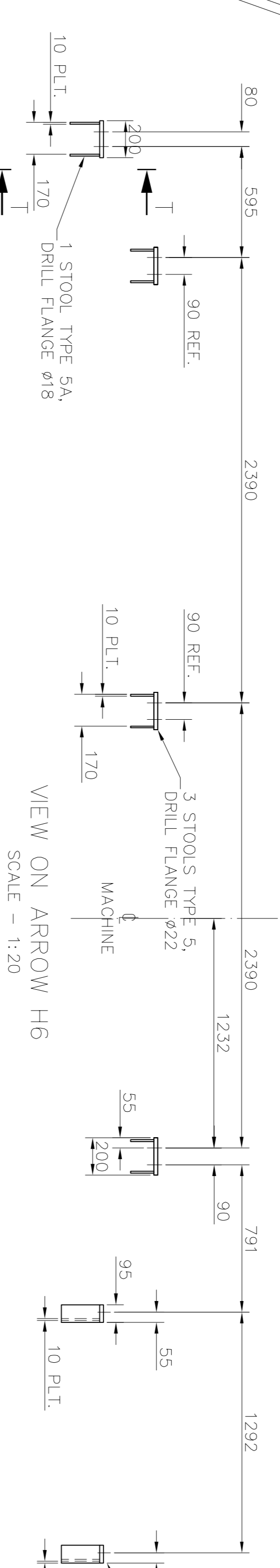

VIEW ON ARROW H6
SCALE - 1:20

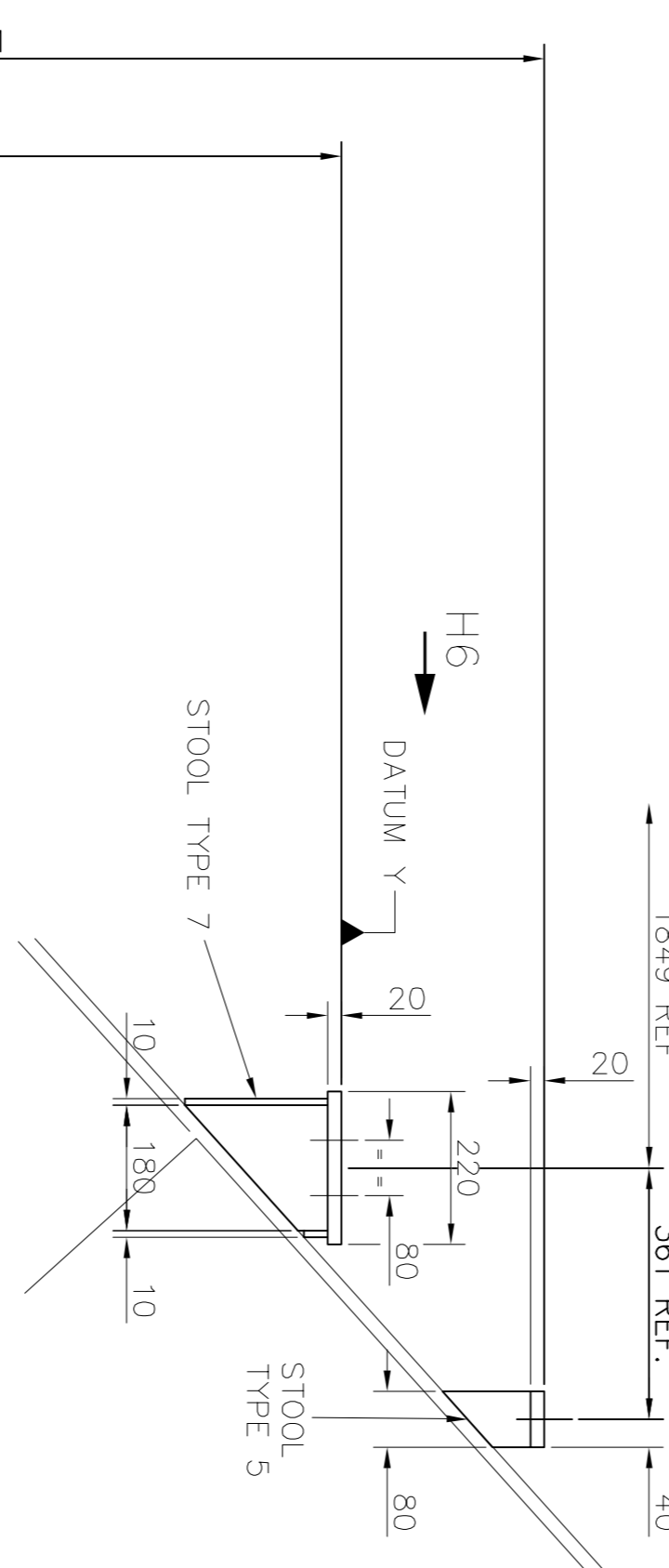

DETAILS OF LOWER MAST ACCESS PLATFORM BRACKETS
SCALE - 1:10

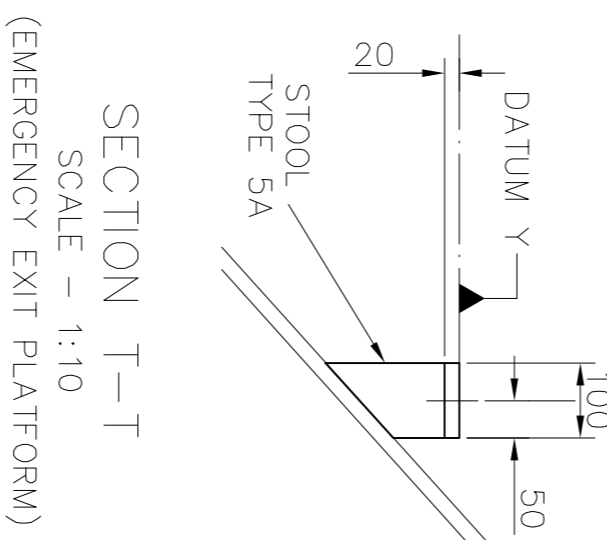

SECTION T-T
SCALE - 1:10
(EMERGENCY EXIT PLATFORM)

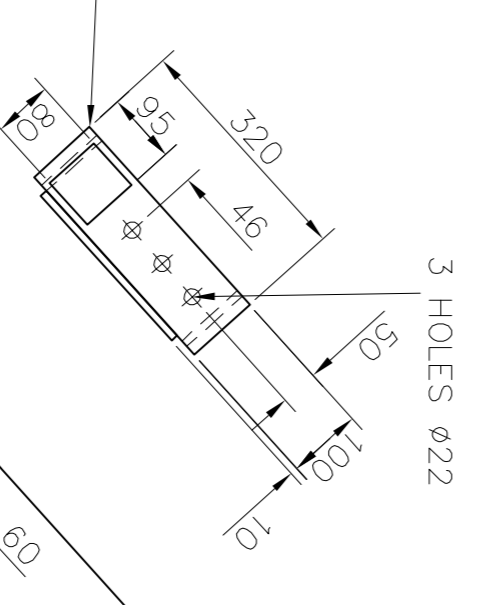

DETAILS OF INTERMEDIATE MAST ACCESS PLATFORM BRACKETS
SCALE - 1:10
NOTE ALL BRACKETS ARE FABRICATED FROM 10 THK. PLATE AND ARE SYMMETRICALLY DISPOSED ABOUT C/L SLEW AS SHOWN ON SHEET 15.

DETAILS OF UPPER MAST ACCESS PLATFORM BRACKETS SCALE - 1:10

DETAILS OF LOWER MAST ACCESS PLATFORM BRACKETS SCALE - 1:10

UNLESS OTHERWISE SPECIFIED IDENTIFY THE ITEM WITH THE DRAWING NUMBER AND ISSUE LEVEL AT THE END IN THE MANNER SHOWN FOR PAINTING AND FOR LUBRICATION SPECIFICATIONS SEE COMPONENT'S LIST

TOLERANCES UNLESS OTHERWISE STATED (PLUS OR MINUS)

RANGE	MACH	FAB	CAST
0-500	±0.25	±0.2	±0.5
501-1000	±0.25	±0.3	±0.5
1001-2000	±0.25	±0.3	±0.6
ABOVE 2000	±0.25	±0.4	±0.6

THIS PRINT AND ALL THE INFORMATION HEREON IS THE PROPERTY OF METSO MINERALS. BULK MATERIALS HANDLING BRISTOL, BRISTOL, ENGLAND. IT IS LOANED SUBJECT TO THE USER'S OBLIGATION TO RETURN IT ON DEMAND UNLESS OTHERWISE PROVIDED IN A WRITTEN AGREEMENT.

UNLESS OTHERWISE SPECIFIED IDENTIFY THE ITEM WITH THE DRAWING NUMBER AND ISSUE LEVEL AT THE END IN THE MANNER SHOWN FOR PAINTING AND FOR LUBRICATION SPECIFICATIONS SEE COMPONENT'S LIST

TOLERANCES UNLESS OTHERWISE STATED (PLUS OR MINUS)

RANGE	MACH	FAB	CAST
0-500	±0.25	±0.2	±0.5
501-1000	±0.25	±0.3	±0.5
1001-2000	±0.25	±0.3	±0.6
ABOVE 2000	±0.25	±0.4	±0.6

SOUTH AFRICAN PORT OPERATIONS
IRON ORE TERMINAL - SALDANHA
STACKER RECLAIMER CONTRACT HQH375
SANCTION No. SB01D1

METSO MINERALS (UK) LTD
BULK MATERIALS HANDLING BRISTOL
PO BOX 821 ASHTON VALE RD
BRISTOL BS99 5ZB ENGLAND

DO NOT SCALE
IF IN DOUBT - ASK

NO.	DATE	BY	APP'D	REVISIONS
1	16/02/06	DDB	DWB	ISSUES RAISED AS BUILT STANDARD REFER TO SHEET 2 OF 17 AS BUILT
2	22/6/06	RD	CF	GENERALLY MODIFIED TO AS BUILT STANDARD 55 DIMS. ADDED (GRID C8, C9)
3	22/6/06	JWH	DWB	NEW SHEET AT REV. C DETAILS ADDED FOR ACCESS SUPPORT STOOLS. SEE ALSO SHTS. 14, 15, 17
4	18/10/02	GBL	GBL	REF. GRID 5B PROFILE OF 30 THK WEBS REVERSED SEE ALSO SHTS 1 TO 12
5	15/08/02	JWH	JWH	FIRST ISSUE
6	15/06/02	USB	NCN	
7	15/7/02	JWH	JWH	

DATE	DESCRIPTION	SCALE
16/02/06	ISSUES RAISED AS BUILT STANDARD REFER TO SHEET 2 OF 17 AS BUILT	1:10, UOS
22/6/06	GENERALLY MODIFIED TO AS BUILT STANDARD 55 DIMS. ADDED (GRID C8, C9)	1:10, UOS
22/6/06	NEW SHEET AT REV. C DETAILS ADDED FOR ACCESS SUPPORT STOOLS. SEE ALSO SHTS. 14, 15, 17	1:10, UOS
18/10/02	REF. GRID 5B PROFILE OF 30 THK WEBS REVERSED SEE ALSO SHTS 1 TO 12	1:10, UOS

ORIGINAL SCALE: A1

NO.	DATE	BY	APP'D	REVISIONS
1	16/02/06	DDB	DWB	ISSUES RAISED AS BUILT STANDARD REFER TO SHEET 2 OF 17 AS BUILT
2	22/6/06	RD	CF	GENERALLY MODIFIED TO AS BUILT STANDARD 55 DIMS. ADDED (GRID C8, C9)
3	22/6/06	JWH	DWB	NEW SHEET AT REV. C DETAILS ADDED FOR ACCESS SUPPORT STOOLS. SEE ALSO SHTS. 14, 15, 17
4	18/10/02	GBL	GBL	REF. GRID 5B PROFILE OF 30 THK WEBS REVERSED SEE ALSO SHTS 1 TO 12
5	15/08/02	JWH	JWH	FIRST ISSUE
6	15/06/02	USB	NCN	
7	15/7/02	JWH	JWH	

ORIGINAL SCALE: A1

DATE	DESCRIPTION	SCALE
16/02/06	ISSUES RAISED AS BUILT STANDARD REFER TO SHEET 2 OF 17 AS BUILT	1:10, UOS
22/6/06	GENERALLY MODIFIED TO AS BUILT STANDARD 55 DIMS. ADDED (GRID C8, C9)	1:10, UOS
22/6/06	NEW SHEET AT REV. C DETAILS ADDED FOR ACCESS SUPPORT STOOLS. SEE ALSO SHTS. 14, 15, 17	1:10, UOS
18/10/02	REF. GRID 5B PROFILE OF 30 THK WEBS REVERSED SEE ALSO SHTS 1 TO 12	1:10, UOS

ASSLY & DETAILS OF SLEW DECK & MAST STRUCTURE

METSO MINERALS (UK) LTD
BULK MATERIALS HANDLING BRISTOL
PO BOX 821 ASHTON VALE RD
BRISTOL BS99 5ZB ENGLAND

SOUTH AFRICAN PORT OPERATIONS
IRON ORE TERMINAL - SALDANHA
STACKER RECLAIMER CONTRACT HQH375
SANCTION No. SB01D1

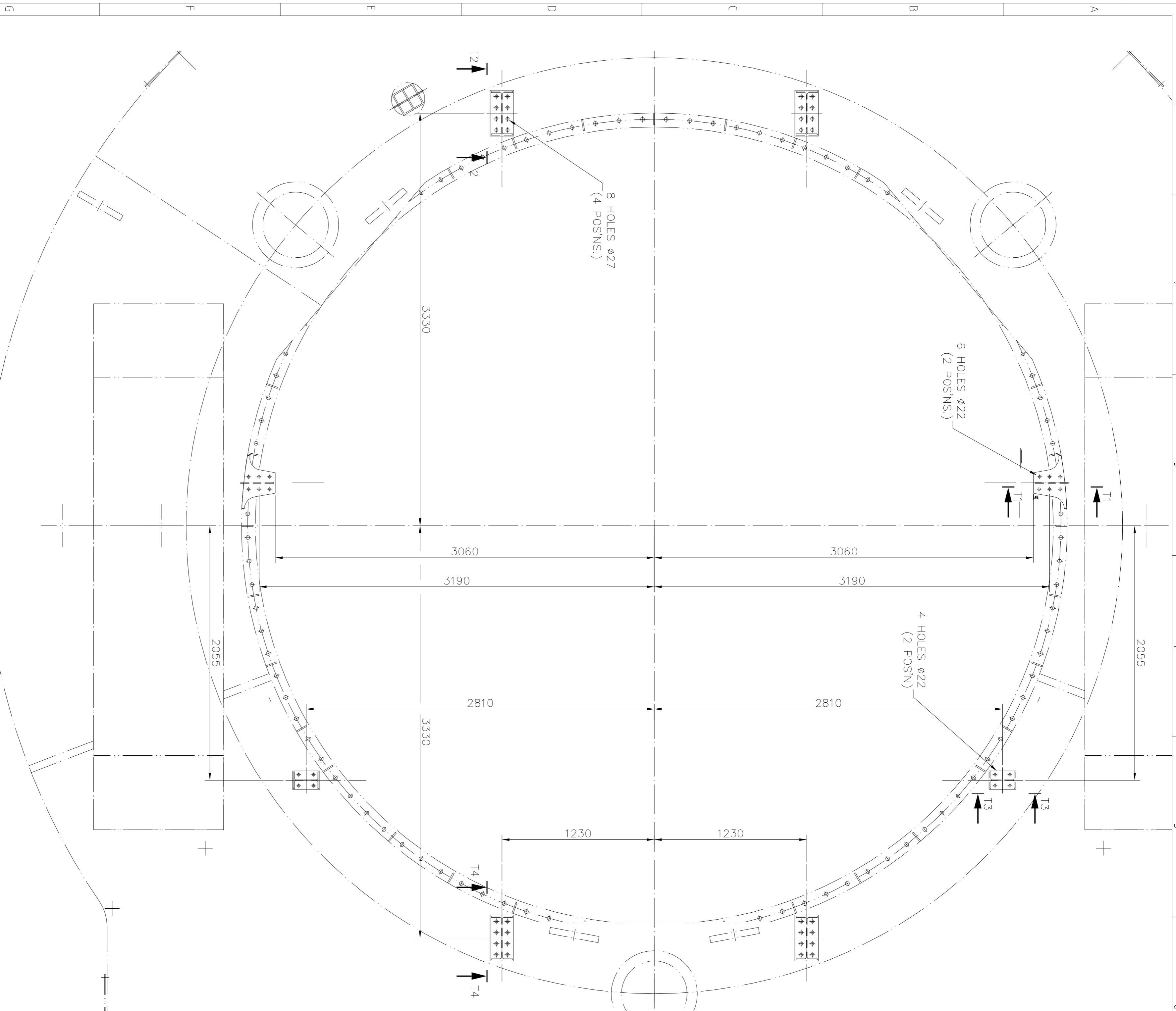

LOCATION PLAN ON TOP FLANGE FOR CHUTE SUPPORT LEG STOOLS

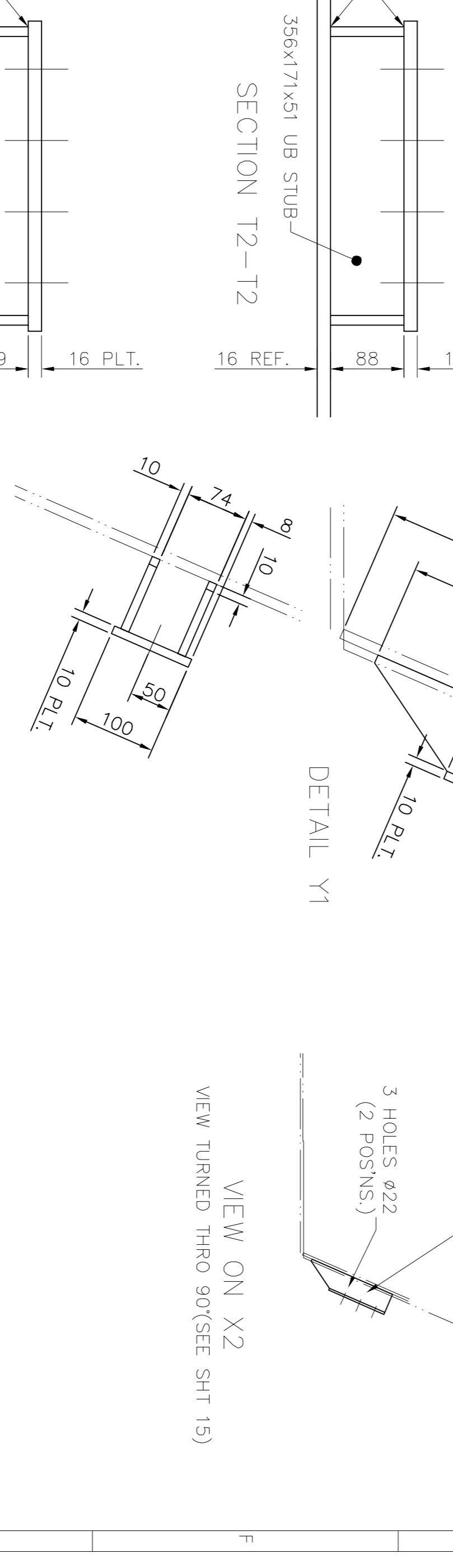
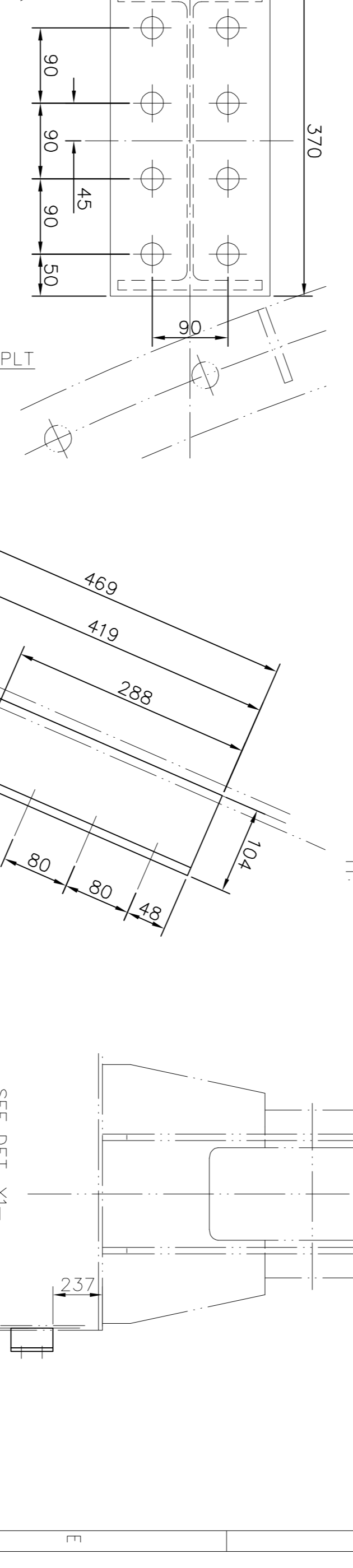
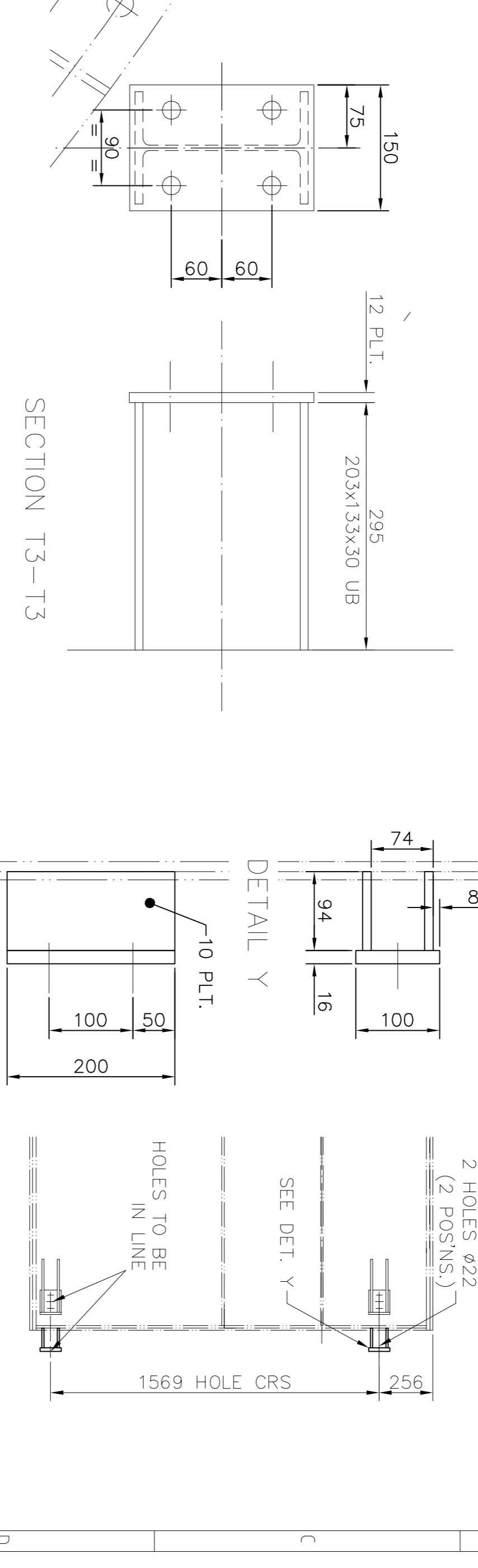
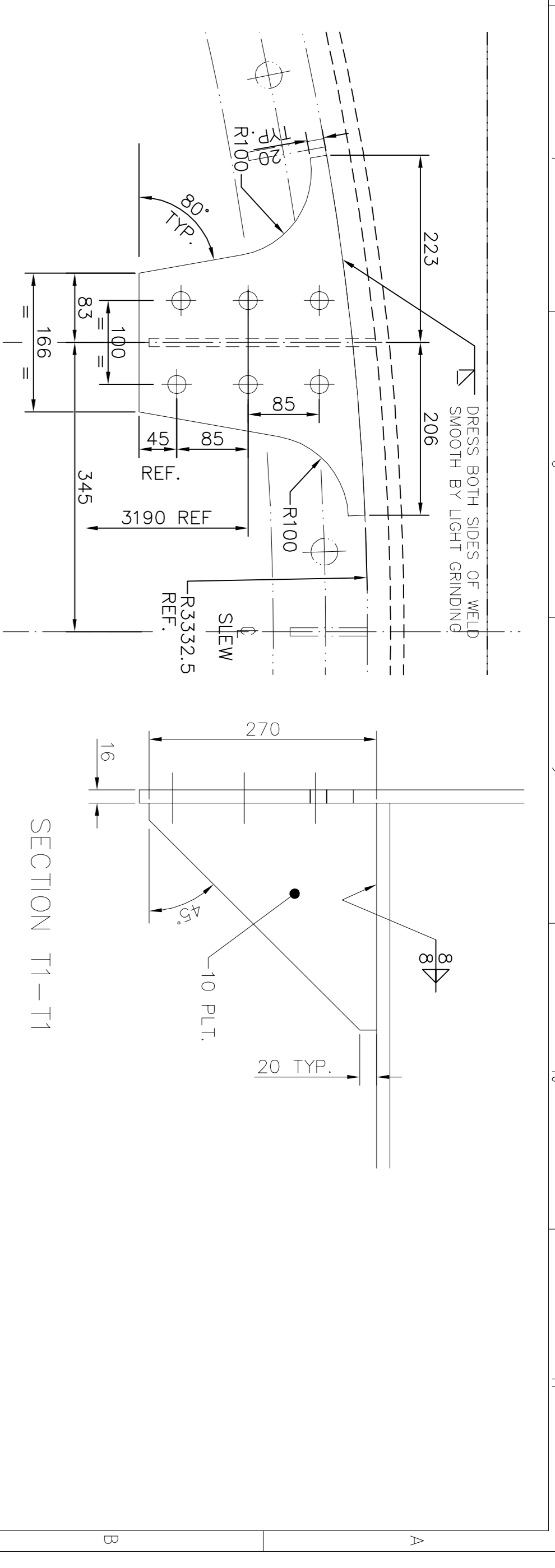

SECTION T1-T1
SECTION T2-T2
SECTION T3-T3
SECTION T4-T4

ISSUES RAISED AS BUILT	ISSUES RAISED AS BUILT REFER TO SHEET 2 OF 17	GENERALLY MODIFIED TO AS BUILT STANDARD NEW SECTION T4-T4 ADDED.	NEW SHEET AT REV. C DETAILS ADDED FOR CHUTE SUPPORT STOODS & APPEX PLATFORM BRACKETS. SEE ALSO SHTS. T4-T16	REF. GRID 5B PROFILE OF 3D THK WEBS REVERSED SEE ALSO SHTS 1 TO 12	FIRST ISSUE																																																																																																																																																																																																																																																																											
<table border="1"> <tr><th>DATE</th><th>DATE</th><th>DATE</th><th>DATE</th><th>DATE</th><th>DATE</th><th>DATE</th><th>DATE</th><th>DATE</th><th>DATE</th><th>DATE</th><th>DATE</th></tr> <tr><td>16.02.06</td><td>22.6.06</td><td>22.6.06</td><td>DEC 04</td><td>JAN 05</td><td>JAN 05</td><td>8/10/02</td><td>18/10/02</td><td>21/10/02</td><td>15.08.02</td><td>16.08.02</td><td>16.08.02</td><td>15.06.02</td><td>29.06.02</td><td>15/7/02</td></tr> <tr><td>DATE</td><td>DATE</td><td>DATE</td><td>DATE</td><td>DATE</td><td>DATE</td><td>DATE</td><td>DATE</td><td>DATE</td><td>DATE</td><td>DATE</td><td>DATE</td><td>DATE</td><td>DATE</td><td>DATE</td></tr> </table>	DATE	DATE	DATE	DATE	DATE	DATE	DATE	DATE	DATE	DATE	DATE	DATE	16.02.06	22.6.06	22.6.06	DEC 04	JAN 05	JAN 05	8/10/02	18/10/02	21/10/02	15.08.02	16.08.02	16.08.02	15.06.02	29.06.02	15/7/02	DATE	DATE	DATE	DATE	DATE	DATE	DATE	DATE	DATE	DATE	DATE	DATE	DATE	DATE	DATE	<table border="1"> <tr><th>DATE</th><th>DATE</th><th>DATE</th><th>DATE</th><th>DATE</th><th>DATE</th><th>DATE</th><th>DATE</th><th>DATE</th><th>DATE</th><th>DATE</th><th>DATE</th><th>DATE</th><th>DATE</th><th>DATE</th></tr> <tr><td>16.02.06</td><td>22.6.06</td><td>22.6.06</td><td>DEC 04</td><td>JAN 05</td><td>JAN 05</td><td>8/10/02</td><td>18/10/02</td><td>21/10/02</td><td>15.08.02</td><td>16.08.02</td><td>16.08.02</td><td>15.06.02</td><td>29.06.02</td><td>15/7/02</td></tr> <tr><td>DATE</td><td>DATE</td><td>DATE</td><td>DATE</td><td>DATE</td><td>DATE</td><td>DATE</td><td>DATE</td><td>DATE</td><td>DATE</td><td>DATE</td><td>DATE</td><td>DATE</td><td>DATE</td><td>DATE</td></tr> </table>	DATE	DATE	DATE	DATE	DATE	DATE	DATE	DATE	DATE	DATE	DATE	DATE	DATE	DATE	DATE	16.02.06	22.6.06	22.6.06	DEC 04	JAN 05	JAN 05	8/10/02	18/10/02	21/10/02	15.08.02	16.08.02	16.08.02	15.06.02	29.06.02	15/7/02	DATE	DATE	DATE	DATE	DATE	DATE	DATE	DATE	DATE	DATE	DATE	DATE	DATE	DATE	DATE	<table border="1"> <tr><th>DATE</th><th>DATE</th><th>DATE</th><th>DATE</th><th>DATE</th><th>DATE</th><th>DATE</th><th>DATE</th><th>DATE</th><th>DATE</th><th>DATE</th><th>DATE</th><th>DATE</th><th>DATE</th><th>DATE</th></tr> <tr><td>16.02.06</td><td>22.6.06</td><td>22.6.06</td><td>DEC 04</td><td>JAN 05</td><td>JAN 05</td><td>8/10/02</td><td>18/10/02</td><td>21/10/02</td><td>15.08.02</td><td>16.08.02</td><td>16.08.02</td><td>15.06.02</td><td>29.06.02</td><td>15/7/02</td></tr> <tr><td>DATE</td><td>DATE</td><td>DATE</td><td>DATE</td><td>DATE</td><td>DATE</td><td>DATE</td><td>DATE</td><td>DATE</td><td>DATE</td><td>DATE</td><td>DATE</td><td>DATE</td><td>DATE</td><td>DATE</td></tr> </table>	DATE	DATE	DATE	DATE	DATE	DATE	DATE	DATE	DATE	DATE	DATE	DATE	DATE	DATE	DATE	16.02.06	22.6.06	22.6.06	DEC 04	JAN 05	JAN 05	8/10/02	18/10/02	21/10/02	15.08.02	16.08.02	16.08.02	15.06.02	29.06.02	15/7/02	DATE	DATE	DATE	DATE	DATE	DATE	DATE	DATE	DATE	DATE	DATE	DATE	DATE	DATE	DATE	<table border="1"> <tr><th>DATE</th><th>DATE</th><th>DATE</th><th>DATE</th><th>DATE</th><th>DATE</th><th>DATE</th><th>DATE</th><th>DATE</th><th>DATE</th><th>DATE</th><th>DATE</th><th>DATE</th><th>DATE</th><th>DATE</th></tr> <tr><td>16.02.06</td><td>22.6.06</td><td>22.6.06</td><td>DEC 04</td><td>JAN 05</td><td>JAN 05</td><td>8/10/02</td><td>18/10/02</td><td>21/10/02</td><td>15.08.02</td><td>16.08.02</td><td>16.08.02</td><td>15.06.02</td><td>29.06.02</td><td>15/7/02</td></tr> <tr><td>DATE</td><td>DATE</td><td>DATE</td><td>DATE</td><td>DATE</td><td>DATE</td><td>DATE</td><td>DATE</td><td>DATE</td><td>DATE</td><td>DATE</td><td>DATE</td><td>DATE</td><td>DATE</td><td>DATE</td></tr> </table>	DATE	DATE	DATE	DATE	DATE	DATE	DATE	DATE	DATE	DATE	DATE	DATE	DATE	DATE	DATE	16.02.06	22.6.06	22.6.06	DEC 04	JAN 05	JAN 05	8/10/02	18/10/02	21/10/02	15.08.02	16.08.02	16.08.02	15.06.02	29.06.02	15/7/02	DATE	DATE	DATE	DATE	DATE	DATE	DATE	DATE	DATE	DATE	DATE	DATE	DATE	DATE	DATE	<table border="1"> <tr><th>DATE</th><th>DATE</th><th>DATE</th><th>DATE</th><th>DATE</th><th>DATE</th><th>DATE</th><th>DATE</th><th>DATE</th><th>DATE</th><th>DATE</th><th>DATE</th><th>DATE</th><th>DATE</th><th>DATE</th></tr> <tr><td>16.02.06</td><td>22.6.06</td><td>22.6.06</td><td>DEC 04</td><td>JAN 05</td><td>JAN 05</td><td>8/10/02</td><td>18/10/02</td><td>21/10/02</td><td>15.08.02</td><td>16.08.02</td><td>16.08.02</td><td>15.06.02</td><td>29.06.02</td><td>15/7/02</td></tr> <tr><td>DATE</td><td>DATE</td><td>DATE</td><td>DATE</td><td>DATE</td><td>DATE</td><td>DATE</td><td>DATE</td><td>DATE</td><td>DATE</td><td>DATE</td><td>DATE</td><td>DATE</td><td>DATE</td><td>DATE</td></tr> </table>	DATE	DATE	DATE	DATE	DATE	DATE	DATE	DATE	DATE	DATE	DATE	DATE	DATE	DATE	DATE	16.02.06	22.6.06	22.6.06	DEC 04	JAN 05	JAN 05	8/10/02	18/10/02	21/10/02	15.08.02	16.08.02	16.08.02	15.06.02	29.06.02	15/7/02	DATE	DATE	DATE	DATE	DATE	DATE	DATE	DATE	DATE	DATE	DATE	DATE	DATE	DATE	DATE	<table border="1"> <tr><th>DATE</th><th>DATE</th><th>DATE</th><th>DATE</th><th>DATE</th><th>DATE</th><th>DATE</th><th>DATE</th><th>DATE</th><th>DATE</th><th>DATE</th><th>DATE</th><th>DATE</th><th>DATE</th><th>DATE</th></tr> <tr><td>16.02.06</td><td>22.6.06</td><td>22.6.06</td><td>DEC 04</td><td>JAN 05</td><td>JAN 05</td><td>8/10/02</td><td>18/10/02</td><td>21/10/02</td><td>15.08.02</td><td>16.08.02</td><td>16.08.02</td><td>15.06.02</td><td>29.06.02</td><td>15/7/02</td></tr> <tr><td>DATE</td><td>DATE</td><td>DATE</td><td>DATE</td><td>DATE</td><td>DATE</td><td>DATE</td><td>DATE</td><td>DATE</td><td>DATE</td><td>DATE</td><td>DATE</td><td>DATE</td><td>DATE</td><td>DATE</td></tr> </table>	DATE	DATE	DATE	DATE	DATE	DATE	DATE	DATE	DATE	DATE	DATE	DATE	DATE	DATE	DATE	16.02.06	22.6.06	22.6.06	DEC 04	JAN 05	JAN 05	8/10/02	18/10/02	21/10/02	15.08.02	16.08.02	16.08.02	15.06.02	29.06.02	15/7/02	DATE	DATE	DATE	DATE	DATE	DATE	DATE	DATE	DATE	DATE	DATE	DATE	DATE	DATE	DATE
DATE	DATE	DATE	DATE	DATE	DATE	DATE	DATE	DATE	DATE	DATE	DATE																																																																																																																																																																																																																																																																					
16.02.06	22.6.06	22.6.06	DEC 04	JAN 05	JAN 05	8/10/02	18/10/02	21/10/02	15.08.02	16.08.02	16.08.02	15.06.02	29.06.02	15/7/02																																																																																																																																																																																																																																																																		
DATE	DATE	DATE	DATE	DATE	DATE	DATE	DATE	DATE	DATE	DATE	DATE	DATE	DATE	DATE																																																																																																																																																																																																																																																																		
DATE	DATE	DATE	DATE	DATE	DATE	DATE	DATE	DATE	DATE	DATE	DATE	DATE	DATE	DATE																																																																																																																																																																																																																																																																		
16.02.06	22.6.06	22.6.06	DEC 04	JAN 05	JAN 05	8/10/02	18/10/02	21/10/02	15.08.02	16.08.02	16.08.02	15.06.02	29.06.02	15/7/02																																																																																																																																																																																																																																																																		
DATE	DATE	DATE	DATE	DATE	DATE	DATE	DATE	DATE	DATE	DATE	DATE	DATE	DATE	DATE																																																																																																																																																																																																																																																																		
DATE	DATE	DATE	DATE	DATE	DATE	DATE	DATE	DATE	DATE	DATE	DATE	DATE	DATE	DATE																																																																																																																																																																																																																																																																		
16.02.06	22.6.06	22.6.06	DEC 04	JAN 05	JAN 05	8/10/02	18/10/02	21/10/02	15.08.02	16.08.02	16.08.02	15.06.02	29.06.02	15/7/02																																																																																																																																																																																																																																																																		
DATE	DATE	DATE	DATE	DATE	DATE	DATE	DATE	DATE	DATE	DATE	DATE	DATE	DATE	DATE																																																																																																																																																																																																																																																																		
DATE	DATE	DATE	DATE	DATE	DATE	DATE	DATE	DATE	DATE	DATE	DATE	DATE	DATE	DATE																																																																																																																																																																																																																																																																		
16.02.06	22.6.06	22.6.06	DEC 04	JAN 05	JAN 05	8/10/02	18/10/02	21/10/02	15.08.02	16.08.02	16.08.02	15.06.02	29.06.02	15/7/02																																																																																																																																																																																																																																																																		
DATE	DATE	DATE	DATE	DATE	DATE	DATE	DATE	DATE	DATE	DATE	DATE	DATE	DATE	DATE																																																																																																																																																																																																																																																																		
DATE	DATE	DATE	DATE	DATE	DATE	DATE	DATE	DATE	DATE	DATE	DATE	DATE	DATE	DATE																																																																																																																																																																																																																																																																		
16.02.06	22.6.06	22.6.06	DEC 04	JAN 05	JAN 05	8/10/02	18/10/02	21/10/02	15.08.02	16.08.02	16.08.02	15.06.02	29.06.02	15/7/02																																																																																																																																																																																																																																																																		
DATE	DATE	DATE	DATE	DATE	DATE	DATE	DATE	DATE	DATE	DATE	DATE	DATE	DATE	DATE																																																																																																																																																																																																																																																																		
DATE	DATE	DATE	DATE	DATE	DATE	DATE	DATE	DATE	DATE	DATE	DATE	DATE	DATE	DATE																																																																																																																																																																																																																																																																		
16.02.06	22.6.06	22.6.06	DEC 04	JAN 05	JAN 05	8/10/02	18/10/02	21/10/02	15.08.02	16.08.02	16.08.02	15.06.02	29.06.02	15/7/02																																																																																																																																																																																																																																																																		
DATE	DATE	DATE	DATE	DATE	DATE	DATE	DATE	DATE	DATE	DATE	DATE	DATE	DATE	DATE																																																																																																																																																																																																																																																																		

UNLESS OTHERWISE SPECIFIED IDENTIFY THE ITEM WITH THE DRAWING NUMBER AND ISSUE LEVEL AT THE END IN THE MANNER SHOWN FOR PAINTING AND FOR LUBRICATION SPECIFICATIONS SEE COMPONENTS LIST.
UNLESS OTHERWISE STATED DIMENSIONS ARE IN MILLIMETRES TOLERANCES UNLESS OTHERWISE STATED PLUS OR MINUS AS RANGE
MACH FAB CAST
0-500 0.25 2 2
501-1000 0.5 3 4
1001-2000 1.0 4 6
ABOVE 2000 2.0 6 10

THIS PRINT AND ALL THE INFORMATION HEREIN IS THE PROPERTY OF METSO MINERALS. Bulk Materials Handling Bristol and must not be made public, copied or used in any way detrimental to our interests. It is loaned subject to return on demand unless furnished under contract provisions.

DO NOT SCALE
IF IN DOUBT - ASK

ASSLY & DETAILS OF
SLEW DECK & MAST STRUCTURE

700418

metso minerals

SOUTH AFRICAN PORT OPERATIONS
IRON ORE TERMINAL - SALDANHA
STACKER RECLAIMER CONTRACT HQH375
SANCTION No. SB01D1

METSO MINERALS (UK LTD)
BULK MATERIALS HANDLING BRISTOL
PO BOX 821 ASHTON VALE RD
BRISTOL BS99 5ZB ENGLAND

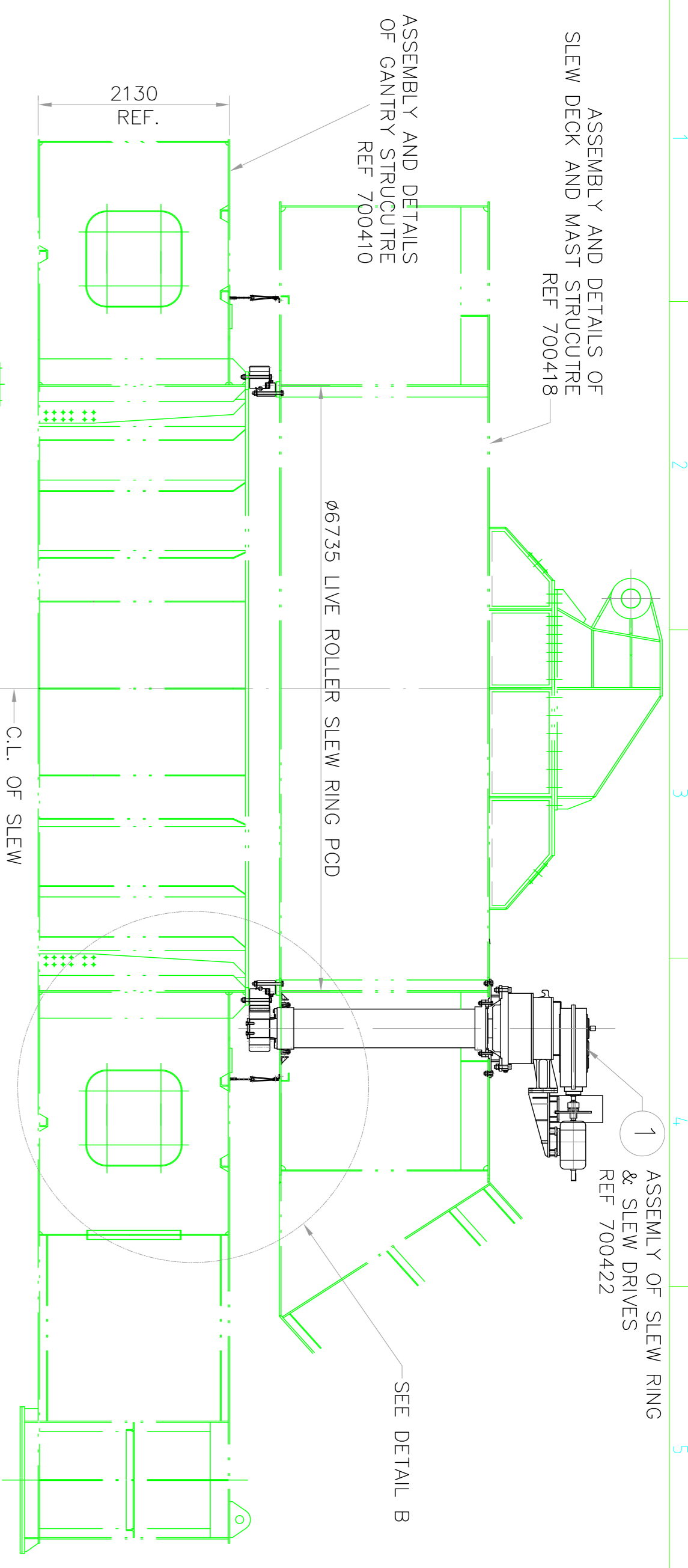

SECTION A-A
CL. OF SLEW

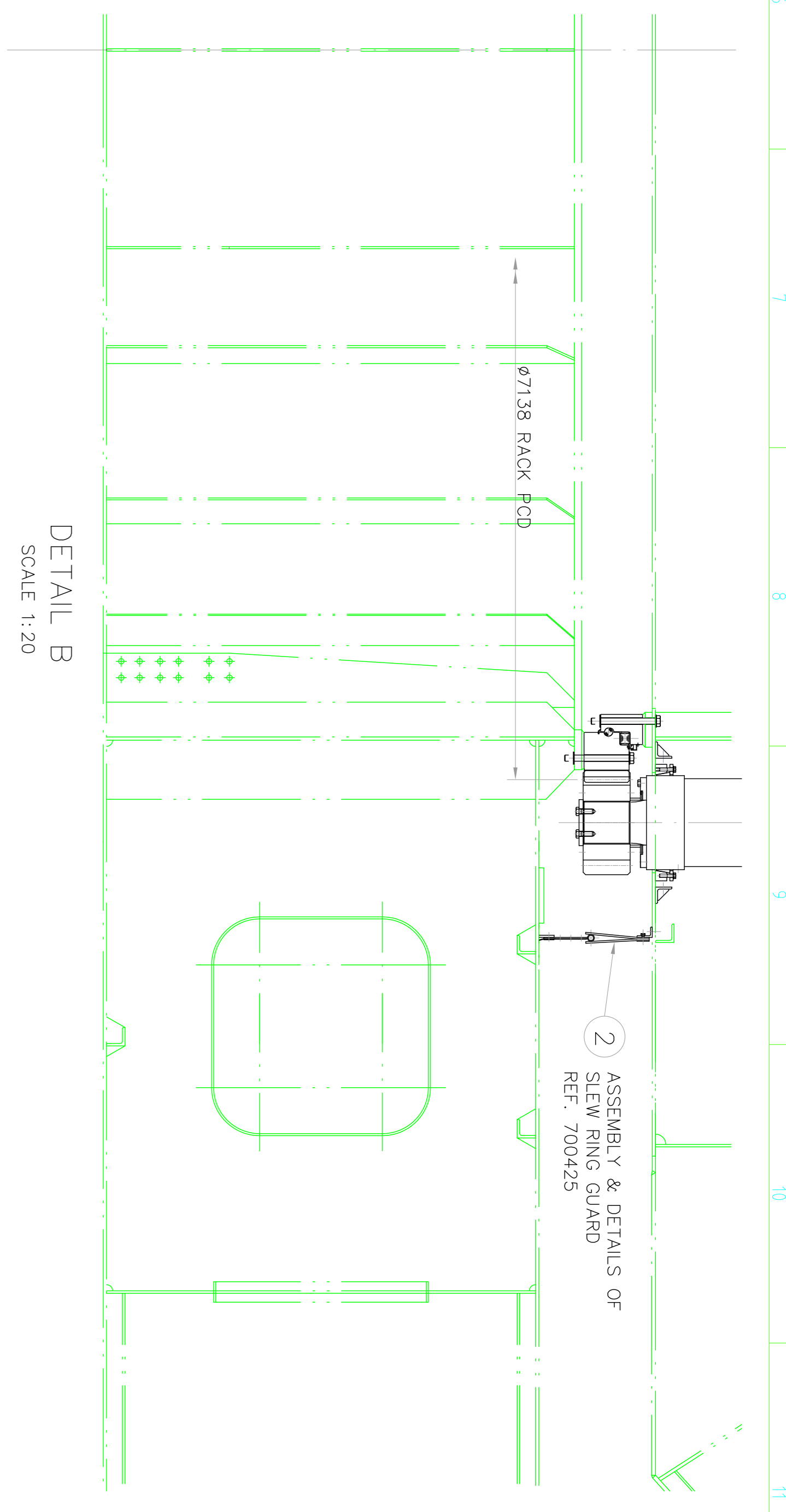

DETAIL B
SCALE 1:20

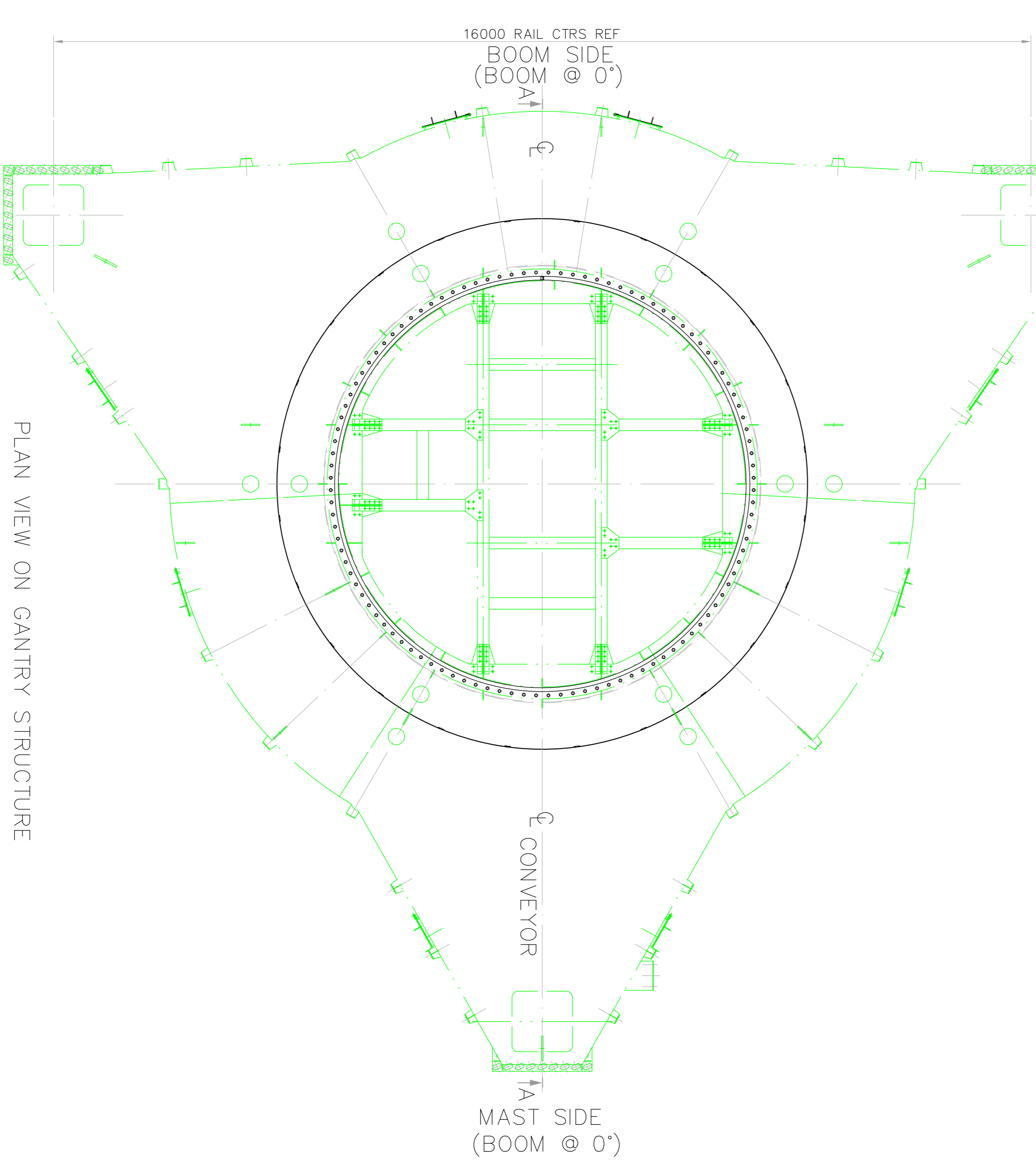

PLAN VIEW ON GANTRY STRUCTURE

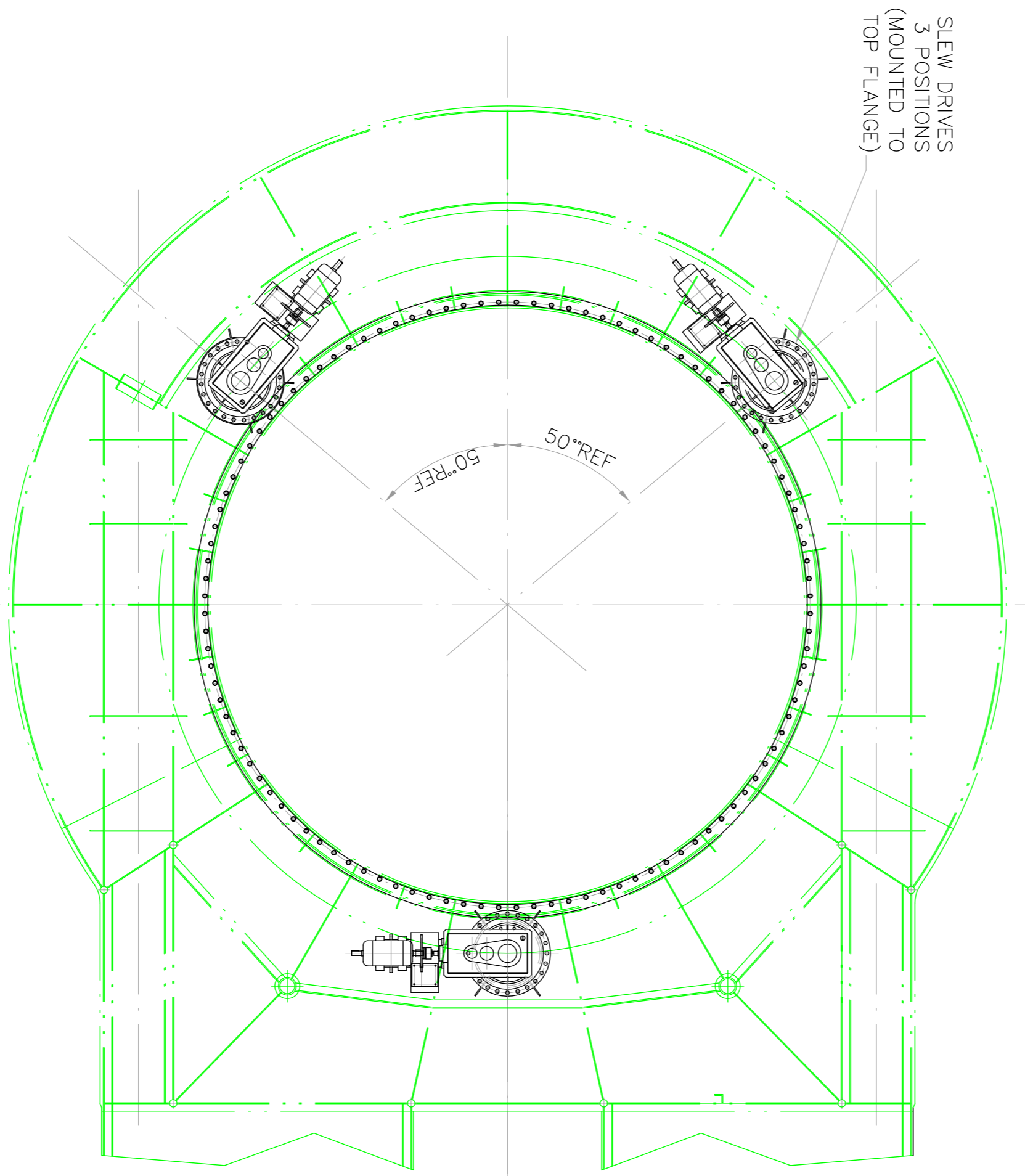

PLAN VIEW ON SLEW DECK LOWER FLANGE

DATE	DESIGNED	APPROVED	DATE	DESIGNED	APPROVED	DATE	DESIGNED	APPROVED	DATE	DESIGNED	APPROVED	DATE	DESIGNED	APPROVED	DATE	DESIGNED	APPROVED
21.10.02	USB		28.10.02	NCN													

<p>UNLESS OTHERWISE SPECIFIED IDENTIFY THE ITEM WITH THE DRAWING NUMBER AND ISSUE LEVEL AT THE DRAWING SYMBOL FOR PAINTING AND FOR LUBRICATION SPECIFICATIONS SEE COMMENT(S) LIST</p> <p>UNLESS OTHERWISE STATED DIMENSIONS ARE IN MILLIMETRES TOLERANCES UNLESS OTHERWISE STATED (PLUS OR MINUS)</p> <table border="1"> <tr> <th>RANGE</th> <th>TOLERANCE</th> <th>FINISH</th> <th>CAST</th> </tr> <tr> <td>0-500</td> <td>±0.25</td> <td>2</td> <td>2</td> </tr> <tr> <td>501-1000</td> <td>±0.5</td> <td>3</td> <td>4</td> </tr> <tr> <td>1001-2000</td> <td>±1.0</td> <td>4</td> <td>6</td> </tr> <tr> <td>ABOVE 2000</td> <td>±2.0</td> <td>6</td> <td>10</td> </tr> </table> <p>THIS PRINT AND ALL THE INFORMATION HEREIN IS THE PROPERTY OF METSO MINERALS. Bulk Materials Handling Bristol and must not be loaned, public, copied or used in any way detrimental to our interests. It is loaned subject to return on demand, unless furnished under contract provisions.</p>	RANGE	TOLERANCE	FINISH	CAST	0-500	±0.25	2	2	501-1000	±0.5	3	4	1001-2000	±1.0	4	6	ABOVE 2000	±2.0	6	10	<p>DRAWN TO BS 8888</p> <p>WELD SYMBOLS TO BS EN 22553</p> <p>PAINT SYMBOLS TO BS EN 12013</p> <p>FINISH SYMBOLS TO BS EN 12013</p> <p>FINISH SYMBOLS TO BS EN 12013</p> <p>MATERIAL & CONDITION SEE MANUFACTURE</p> <p>MATL</p> <p>SPEC</p> <p>GRADE</p> <p>MASS</p>	<p>DO NOT SCALE</p> <p>IF IN DOUBT - ASK</p>	<p>TRIMED</p> <p>PAINTED</p> <p>FINISHED</p> <p>MANUFACTURED</p>	<p>SOUTH AFRICAN PORT OPERATIONS</p> <p>IRON ORE TERMINAL - SALDANHA</p> <p>STACKER RECLAIMER CONTRACT HDH375</p> <p>SAANCTIEN No. SB01 D1</p>	<p>METSO MINERALS (UK) LTD</p> <p>BULK MATERIALS HANDLING BRISTOL</p> <p>PO BOX 821 ASHTON VALE RD</p> <p>BRISTOL, BS99 5ZB ENGLAND</p>	<p>ASSEMBLY OF SLEW GEAR</p>	<p>DRAWING NUMBER</p> <p>700421</p>	<p>SHEET OF</p> <p>1 1 1</p> <p>ISSUE</p> <p>A</p>
RANGE	TOLERANCE	FINISH	CAST																									
0-500	±0.25	2	2																									
501-1000	±0.5	3	4																									
1001-2000	±1.0	4	6																									
ABOVE 2000	±2.0	6	10																									

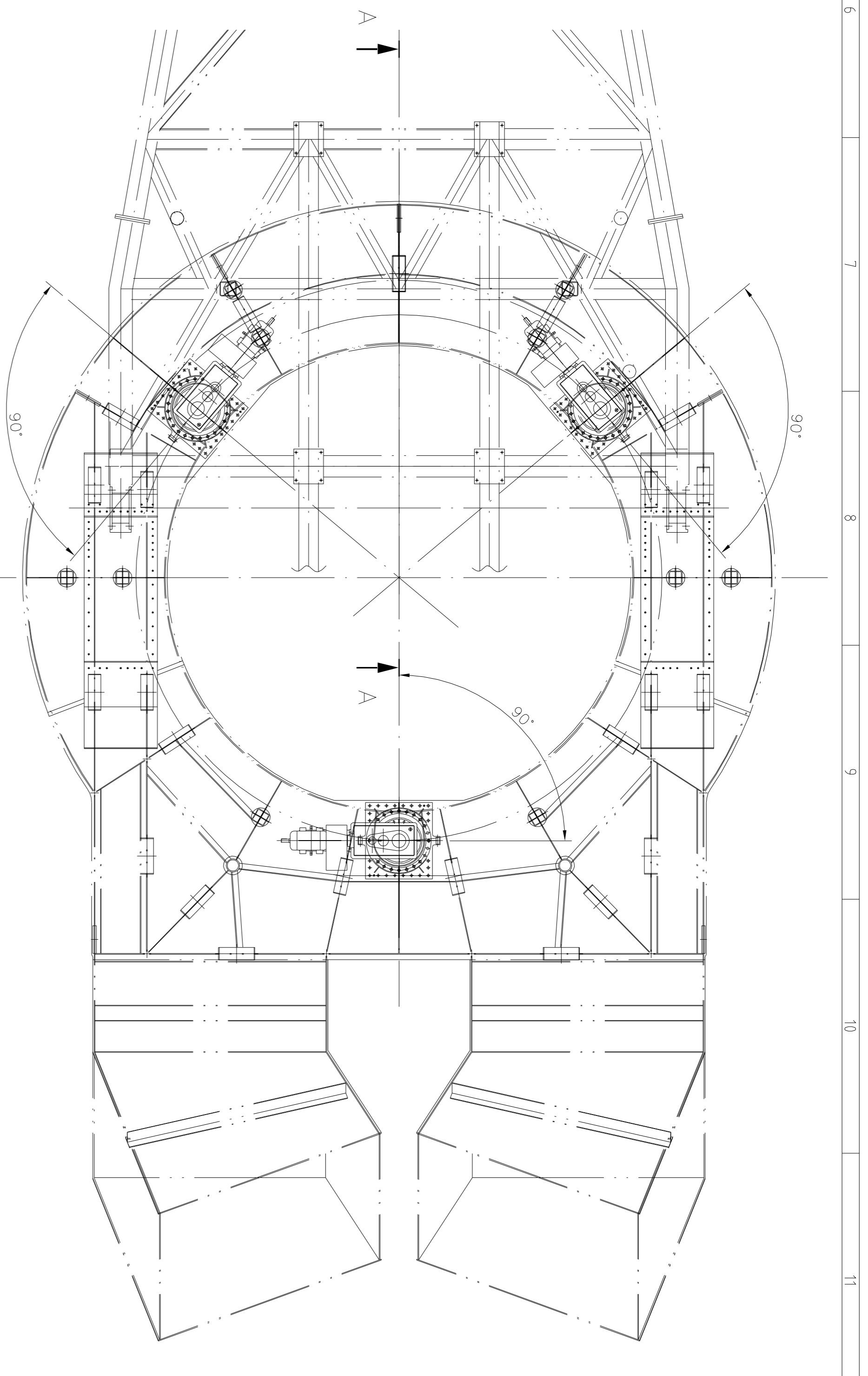
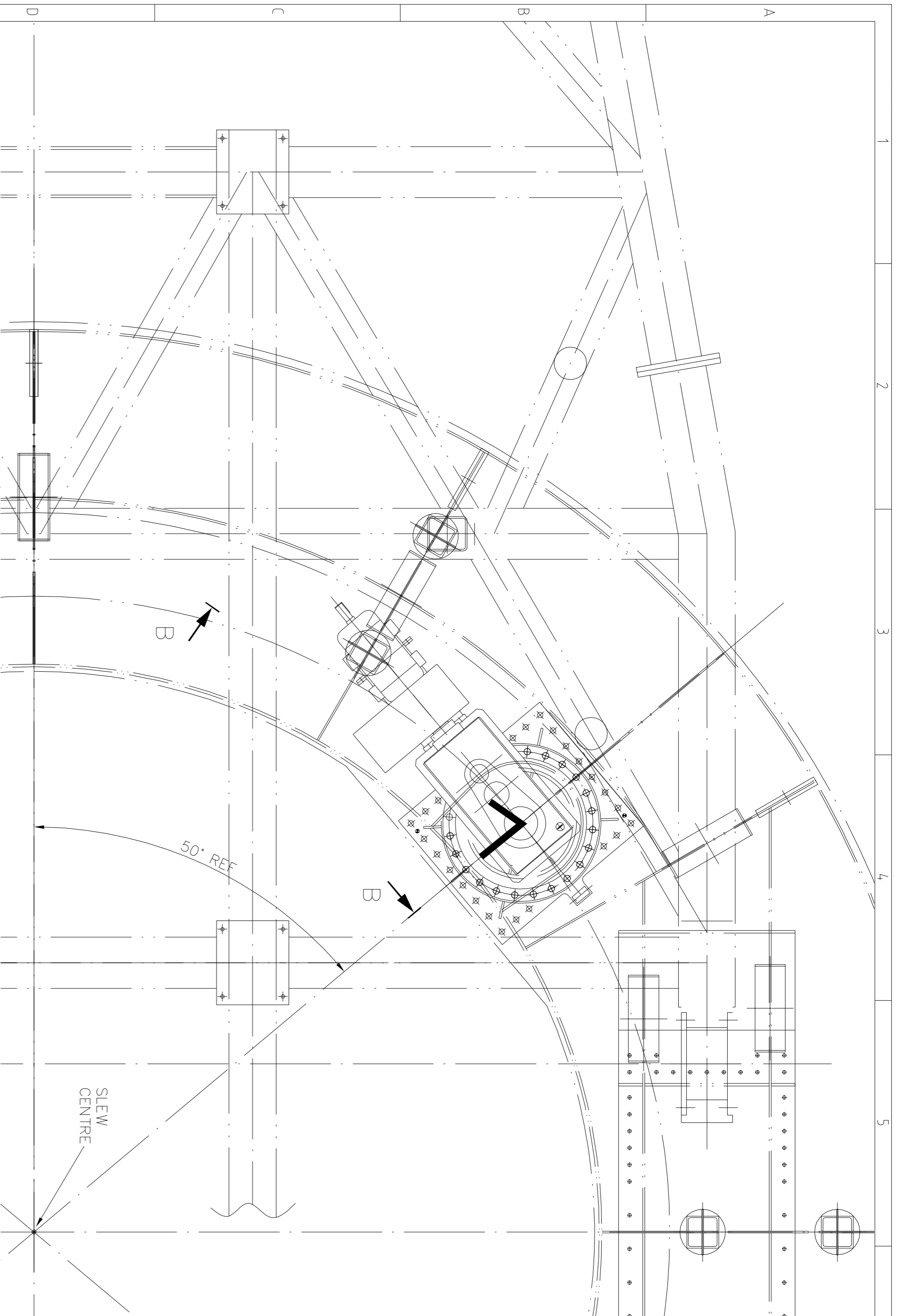

PLAN VIEW ON SLEW DECK
SHOWING POSITION OF
ALL THREE SLEW DRIVES

NOTES :-

- THIS DRAWING TO BE READ IN CONJUNCTION WITH :-
DOCUMENT 27496/D15, MANUFACTURING SPECIFICATION.
- MATERIAL: PLATES, FLATS & OPEN ROLLED SECTIONS TO SABS 1431 GRADE 300WA.
 - CERTIFICATION: CHEMICAL & MECHANICAL TEST CERTIFICATES REQUIRED FOR ALL MATERIALS.
 - WELDING: ALL WELDING TO BE CARRIED OUT IN ACCORDANCE WITH THE MANUFACTURING SPECIFICATION. ALL WELDS ARE TO BE 8mm CONTINUOUS FILETS ON BOTH SIDES OR FULL STRENGTH BUTT WELDS U.O.S.
 - INSPECTION AND TESTING: NDT OF WELDS TO BE CARRIED OUT IN ACCORDANCE WITH MANUFACTURING SPECIFICATION.
 - BOLTED JOINTS: TO CONFORM TO MANUFACTURING SPECIFICATION.
 - SURFACE TREATMENT: TO CONFORM TO MANUFACTURING SPECIFICATION.
 - SLEW RING AND DRIVES TO BE INSTALLED AS PER SPECIFICATION 27496/D82, MECHANICAL SITE INSTALLATION SCHEDULE.

MATING SURFACE BETWEEN SLEW DECK AND SLEW DRIVE SUPPORT STOOL IS A HFG JOINT AND IS TO BE LEFT UNPAINTED TYPICAL 3 POSITIONS.

SECTION AA WITH BOOM FULLY LOWERED

<p>ISSUES RAISED GEN.UPDATE SPLIT RETAINER PLATE TO ALLOW PASSAGE FOR PINION. DRIVE 1 (9mm LONGER SLEEVE) DRIVE 2 (9mm LONGER SLEEVE) DRIVE 3 (SPAGERS ADDED TO LOCAL PINION AS BUILT)</p> <p>SHEET 5. ADDED SHOWING REQUIRED POSITION OF SLEW WEAR MEASUREMENT NOTE ADDED TO SHEET 3.</p> <p>SEE SHEET 3</p> <p>ITEM 2.3, AND 4, REVISED MASS WAS 27416 kg</p> <p>ISSUED FOR MANUFACTURE</p> <p>UNLESS OTHERWISE SPECIFIED IDENTIFY THE ITEM WITH THE DRAWING NUMBER AND ISSUE LEVEL AT \blacktriangledown AND IN THE MANNER SHOWN FOR PAINTING AND FOR LUBRICATION SPECIFICATIONS SEE COMPONENTS LIST</p> <p>UNLESS OTHERWISE STATED DIMENSIONS ARE IN MILLIMETRES TOLERANCES UNLESS OTHERWISE STATED (PLUS OR MINUS)</p> <table border="1"> <tr> <td>RANGE</td> <td>MACH</td> <td>FAB</td> <td>CAST</td> </tr> <tr> <td>0-500</td> <td>0.25</td> <td>2</td> <td>2</td> </tr> <tr> <td>501-1000</td> <td>0.5</td> <td>3</td> <td>4</td> </tr> <tr> <td>1001-2000</td> <td>1.0</td> <td>4</td> <td>6</td> </tr> <tr> <td>ABOVE 2000</td> <td>2.0</td> <td>6</td> <td>10</td> </tr> </table> <p>This print and all the information herein is the property of Metso Minerals. Bulk Materials Handling Bristol and must not be made public, copied or used in any way detrimental to our interests. It is loaned subject to return on demand unless furnished under contract provisions.</p> <p>DRAWN TO BS 8888 WELD SYMBOLS TO AWS/AISI 12 SURFACE TEXTURE TO BS 1315, R1.60 MATERIAL & CONDITION BEFORE MANUFACTURE</p> <p>THIRD ANGLE DRAWING</p> <p>DO NOT SCALE IF IN DOUBT - ASK</p> <p>ASSY AND DETAILS OF SLEW RING AND SLEW DRIVES</p> <p>metso minerals</p> <p>SOUTH AFRICAN PORT OPERATIONS IRON ORE TERMINAL - SALDANHA STACKER RECLAIMER CONTRACT HQH375 SANCTION NO. SB01 D1</p> <p>METSO MINERALS (UK) LTD BULK MATERIALS HANDLING BRISTOL PO BOX 821 ASHTON VALE RD BRISTOL BS99 5ZB ENGLAND</p>	RANGE	MACH	FAB	CAST	0-500	0.25	2	2	501-1000	0.5	3	4	1001-2000	1.0	4	6	ABOVE 2000	2.0	6	10	<table border="1"> <thead> <tr> <th>DATE</th> <th>DATE</th> <th>DATE</th> <th>DATE</th> <th>DATE</th> <th>DATE</th> <th>DATE</th> <th>DATE</th> <th>DATE</th> <th>DATE</th> <th>DATE</th> <th>DATE</th> <th>DATE</th> <th>DATE</th> <th>DATE</th> <th>DATE</th> </tr> </thead> <tbody> <tr> <td>16/02/06</td> <td>22/6/06</td> <td>22/6/06</td> <td>14/2/03</td> <td>14/2/03</td> <td>23 JAN 03</td> <td>23 JAN 03</td> <td>23 JAN 03</td> <td>5/12/02</td> <td>6/12/02</td> <td>6/12/02</td> <td>OCT 02</td> <td>27/11/02</td> <td>03/12/02</td> <td></td> <td></td> </tr> <tr> <td>DRBN</td> <td>CHECKED</td> <td>APPROVED</td> <td>DRBN</td> <td>CHECKED</td> <td>APPROVED</td> <td>DRBN</td> <td>CHECKED</td> <td>APPROVED</td> <td>DRBN</td> <td>CHECKED</td> <td>APPROVED</td> <td>DRBN</td> <td>CHECKED</td> <td>APPROVED</td> <td>DRBN</td> </tr> <tr> <td>DDS</td> <td>RD</td> <td>JWH</td> <td>FAB</td> <td>JWH</td> <td>JWH</td> <td>JWH</td> <td>FAB</td> <td>FAB</td> <td>JWH</td> <td>JWH</td> <td>USB</td> <td>FAB</td> <td>JWH</td> <td>JWH</td> <td>JWH</td> </tr> </tbody> </table> <p>MASS 27382kg ORIGINAL SCALE 1:20 SIZE DRAWING NUMBER A1 700422 SHEET OF 5 ISSUE E</p>	DATE	DATE	DATE	DATE	DATE	DATE	DATE	DATE	DATE	DATE	DATE	DATE	DATE	DATE	DATE	DATE	16/02/06	22/6/06	22/6/06	14/2/03	14/2/03	23 JAN 03	23 JAN 03	23 JAN 03	5/12/02	6/12/02	6/12/02	OCT 02	27/11/02	03/12/02			DRBN	CHECKED	APPROVED	DRBN	CHECKED	APPROVED	DRBN	CHECKED	APPROVED	DRBN	CHECKED	APPROVED	DRBN	CHECKED	APPROVED	DRBN	DDS	RD	JWH	FAB	JWH	JWH	JWH	FAB	FAB	JWH	JWH	USB	FAB	JWH	JWH	JWH
RANGE	MACH	FAB	CAST																																																																																		
0-500	0.25	2	2																																																																																		
501-1000	0.5	3	4																																																																																		
1001-2000	1.0	4	6																																																																																		
ABOVE 2000	2.0	6	10																																																																																		
DATE	DATE	DATE	DATE	DATE	DATE	DATE	DATE	DATE	DATE	DATE	DATE	DATE	DATE	DATE	DATE																																																																						
16/02/06	22/6/06	22/6/06	14/2/03	14/2/03	23 JAN 03	23 JAN 03	23 JAN 03	5/12/02	6/12/02	6/12/02	OCT 02	27/11/02	03/12/02																																																																								
DRBN	CHECKED	APPROVED	DRBN	CHECKED	APPROVED	DRBN	CHECKED	APPROVED	DRBN	CHECKED	APPROVED	DRBN	CHECKED	APPROVED	DRBN																																																																						
DDS	RD	JWH	FAB	JWH	JWH	JWH	FAB	FAB	JWH	JWH	USB	FAB	JWH	JWH	JWH																																																																						

18027 Issue 4 July 2002

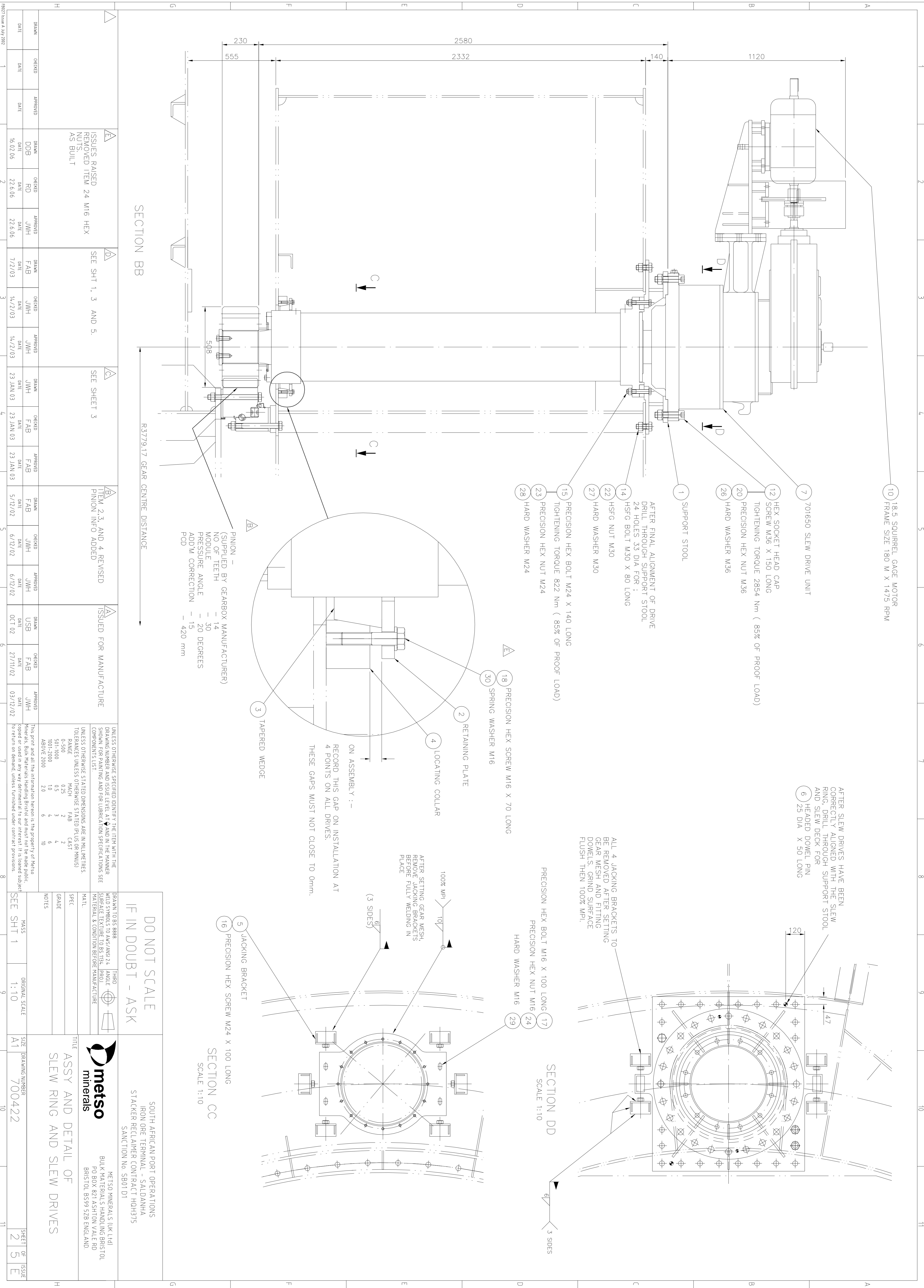

<p>ISSUES RAISED REMOVED ITEM 24 M16 HEX NUTS AS BUILT</p>	<p>SEE SHT 1, 3 AND 5.</p>	<p>SEE SHEET 3</p>	<p>ITEM 2, 3, AND 4 REVISED PINION INFO ADDED</p>	<p>ISSUED FOR MANUFACTURE</p>	<p>UNLESS OTHERWISE SPECIFIED IDENTIFY THE ITEM WITH THE DRAWING NUMBER AND ISSUE LEVEL AT THE END OF THE DRAWING IN THE MANNER SHOWN FOR PAINTING AND FOR LUBRICATION SPECIFICATIONS SEE COMPONENTS LIST.</p> <p>TOLERANCES UNLESS OTHERWISE STATED ARE IN MILLIMETRES</p> <table border="1"> <tr> <td>RANGE</td> <td>MACH</td> <td>FAB</td> <td>CAST</td> </tr> <tr> <td>0-500</td> <td>0.25</td> <td>2</td> <td>4</td> </tr> <tr> <td>501-1000</td> <td>0.5</td> <td>3</td> <td>4</td> </tr> <tr> <td>1001-2000</td> <td>1.0</td> <td>6</td> <td>6</td> </tr> <tr> <td>ABOVE 2000</td> <td>2.0</td> <td>6</td> <td>10</td> </tr> </table>	RANGE	MACH	FAB	CAST	0-500	0.25	2	4	501-1000	0.5	3	4	1001-2000	1.0	6	6	ABOVE 2000	2.0	6	10																																																																																																																																																																																																																																																																																																											
RANGE	MACH	FAB	CAST																																																																																																																																																																																																																																																																																																																																	
0-500	0.25	2	4																																																																																																																																																																																																																																																																																																																																	
501-1000	0.5	3	4																																																																																																																																																																																																																																																																																																																																	
1001-2000	1.0	6	6																																																																																																																																																																																																																																																																																																																																	
ABOVE 2000	2.0	6	10																																																																																																																																																																																																																																																																																																																																	
<table border="1"> <tr> <th>DATE</th> <th>APPROVED</th> <th>DATE</th> <th>APPROVED</th> <th>DATE</th> <th>APPROVED</th> <th>DATE</th> <th>APPROVED</th> <th>DATE</th> <th>APPROVED</th> <th>DATE</th> <th>APPROVED</th> </tr> <tr> <td>16/02/06</td> <td>DDB</td> <td>22/6/06</td> <td>RD</td> <td>7/2/03</td> <td>FAB</td> <td>14/2/03</td> <td>JWH</td> <td>23 JAN 03</td> <td>FAB</td> <td>23 JAN 03</td> <td>JWH</td> </tr> </table>	DATE	APPROVED	DATE	APPROVED	DATE	APPROVED	DATE	APPROVED	DATE	APPROVED	DATE	APPROVED	16/02/06	DDB	22/6/06	RD	7/2/03	FAB	14/2/03	JWH	23 JAN 03	FAB	23 JAN 03	JWH	<table border="1"> <tr> <th>DATE</th> <th>APPROVED</th> <th>DATE</th> <th>APPROVED</th> <th>DATE</th> <th>APPROVED</th> <th>DATE</th> <th>APPROVED</th> <th>DATE</th> <th>APPROVED</th> <th>DATE</th> <th>APPROVED</th> </tr> <tr> <td>16/02/06</td> <td>DDB</td> <td>22/6/06</td> <td>RD</td> <td>7/2/03</td> <td>FAB</td> <td>14/2/03</td> <td>JWH</td> <td>23 JAN 03</td> <td>FAB</td> <td>23 JAN 03</td> <td>JWH</td> </tr> </table>	DATE	APPROVED	DATE	APPROVED	DATE	APPROVED	DATE	APPROVED	DATE	APPROVED	DATE	APPROVED	16/02/06	DDB	22/6/06	RD	7/2/03	FAB	14/2/03	JWH	23 JAN 03	FAB	23 JAN 03	JWH	<table border="1"> <tr> <th>DATE</th> <th>APPROVED</th> <th>DATE</th> <th>APPROVED</th> <th>DATE</th> <th>APPROVED</th> <th>DATE</th> <th>APPROVED</th> <th>DATE</th> <th>APPROVED</th> <th>DATE</th> <th>APPROVED</th> </tr> <tr> <td>16/02/06</td> <td>DDB</td> <td>22/6/06</td> <td>RD</td> <td>7/2/03</td> <td>FAB</td> <td>14/2/03</td> <td>JWH</td> <td>23 JAN 03</td> <td>FAB</td> <td>23 JAN 03</td> <td>JWH</td> </tr> </table>	DATE	APPROVED	DATE	APPROVED	DATE	APPROVED	DATE	APPROVED	DATE	APPROVED	DATE	APPROVED	16/02/06	DDB	22/6/06	RD	7/2/03	FAB	14/2/03	JWH	23 JAN 03	FAB	23 JAN 03	JWH	<table border="1"> <tr> <th>DATE</th> <th>APPROVED</th> <th>DATE</th> <th>APPROVED</th> <th>DATE</th> <th>APPROVED</th> <th>DATE</th> <th>APPROVED</th> <th>DATE</th> <th>APPROVED</th> <th>DATE</th> <th>APPROVED</th> </tr> <tr> <td>16/02/06</td> <td>DDB</td> <td>22/6/06</td> <td>RD</td> <td>7/2/03</td> <td>FAB</td> <td>14/2/03</td> <td>JWH</td> <td>23 JAN 03</td> <td>FAB</td> <td>23 JAN 03</td> <td>JWH</td> </tr> </table>	DATE	APPROVED	DATE	APPROVED	DATE	APPROVED	DATE	APPROVED	DATE	APPROVED	DATE	APPROVED	16/02/06	DDB	22/6/06	RD	7/2/03	FAB	14/2/03	JWH	23 JAN 03	FAB	23 JAN 03	JWH	<table border="1"> <tr> <th>DATE</th> <th>APPROVED</th> <th>DATE</th> <th>APPROVED</th> <th>DATE</th> <th>APPROVED</th> <th>DATE</th> <th>APPROVED</th> <th>DATE</th> <th>APPROVED</th> <th>DATE</th> <th>APPROVED</th> </tr> <tr> <td>16/02/06</td> <td>DDB</td> <td>22/6/06</td> <td>RD</td> <td>7/2/03</td> <td>FAB</td> <td>14/2/03</td> <td>JWH</td> <td>23 JAN 03</td> <td>FAB</td> <td>23 JAN 03</td> <td>JWH</td> </tr> </table>	DATE	APPROVED	DATE	APPROVED	DATE	APPROVED	DATE	APPROVED	DATE	APPROVED	DATE	APPROVED	16/02/06	DDB	22/6/06	RD	7/2/03	FAB	14/2/03	JWH	23 JAN 03	FAB	23 JAN 03	JWH	<table border="1"> <tr> <th>DATE</th> <th>APPROVED</th> <th>DATE</th> <th>APPROVED</th> <th>DATE</th> <th>APPROVED</th> <th>DATE</th> <th>APPROVED</th> <th>DATE</th> <th>APPROVED</th> <th>DATE</th> <th>APPROVED</th> </tr> <tr> <td>16/02/06</td> <td>DDB</td> <td>22/6/06</td> <td>RD</td> <td>7/2/03</td> <td>FAB</td> <td>14/2/03</td> <td>JWH</td> <td>23 JAN 03</td> <td>FAB</td> <td>23 JAN 03</td> <td>JWH</td> </tr> </table>	DATE	APPROVED	DATE	APPROVED	DATE	APPROVED	DATE	APPROVED	DATE	APPROVED	DATE	APPROVED	16/02/06	DDB	22/6/06	RD	7/2/03	FAB	14/2/03	JWH	23 JAN 03	FAB	23 JAN 03	JWH	<table border="1"> <tr> <th>DATE</th> <th>APPROVED</th> <th>DATE</th> <th>APPROVED</th> <th>DATE</th> <th>APPROVED</th> <th>DATE</th> <th>APPROVED</th> <th>DATE</th> <th>APPROVED</th> <th>DATE</th> <th>APPROVED</th> </tr> <tr> <td>16/02/06</td> <td>DDB</td> <td>22/6/06</td> <td>RD</td> <td>7/2/03</td> <td>FAB</td> <td>14/2/03</td> <td>JWH</td> <td>23 JAN 03</td> <td>FAB</td> <td>23 JAN 03</td> <td>JWH</td> </tr> </table>	DATE	APPROVED	DATE	APPROVED	DATE	APPROVED	DATE	APPROVED	DATE	APPROVED	DATE	APPROVED	16/02/06	DDB	22/6/06	RD	7/2/03	FAB	14/2/03	JWH	23 JAN 03	FAB	23 JAN 03	JWH	<table border="1"> <tr> <th>DATE</th> <th>APPROVED</th> <th>DATE</th> <th>APPROVED</th> <th>DATE</th> <th>APPROVED</th> <th>DATE</th> <th>APPROVED</th> <th>DATE</th> <th>APPROVED</th> <th>DATE</th> <th>APPROVED</th> </tr> <tr> <td>16/02/06</td> <td>DDB</td> <td>22/6/06</td> <td>RD</td> <td>7/2/03</td> <td>FAB</td> <td>14/2/03</td> <td>JWH</td> <td>23 JAN 03</td> <td>FAB</td> <td>23 JAN 03</td> <td>JWH</td> </tr> </table>	DATE	APPROVED	DATE	APPROVED	DATE	APPROVED	DATE	APPROVED	DATE	APPROVED	DATE	APPROVED	16/02/06	DDB	22/6/06	RD	7/2/03	FAB	14/2/03	JWH	23 JAN 03	FAB	23 JAN 03	JWH	<table border="1"> <tr> <th>DATE</th> <th>APPROVED</th> <th>DATE</th> <th>APPROVED</th> <th>DATE</th> <th>APPROVED</th> <th>DATE</th> <th>APPROVED</th> <th>DATE</th> <th>APPROVED</th> <th>DATE</th> <th>APPROVED</th> </tr> <tr> <td>16/02/06</td> <td>DDB</td> <td>22/6/06</td> <td>RD</td> <td>7/2/03</td> <td>FAB</td> <td>14/2/03</td> <td>JWH</td> <td>23 JAN 03</td> <td>FAB</td> <td>23 JAN 03</td> <td>JWH</td> </tr> </table>	DATE	APPROVED	DATE	APPROVED	DATE	APPROVED	DATE	APPROVED	DATE	APPROVED	DATE	APPROVED	16/02/06	DDB	22/6/06	RD	7/2/03	FAB	14/2/03	JWH	23 JAN 03	FAB	23 JAN 03	JWH	<table border="1"> <tr> <th>DATE</th> <th>APPROVED</th> <th>DATE</th> <th>APPROVED</th> <th>DATE</th> <th>APPROVED</th> <th>DATE</th> <th>APPROVED</th> <th>DATE</th> <th>APPROVED</th> <th>DATE</th> <th>APPROVED</th> </tr> <tr> <td>16/02/06</td> <td>DDB</td> <td>22/6/06</td> <td>RD</td> <td>7/2/03</td> <td>FAB</td> <td>14/2/03</td> <td>JWH</td> <td>23 JAN 03</td> <td>FAB</td> <td>23 JAN 03</td> <td>JWH</td> </tr> </table>	DATE	APPROVED	DATE	APPROVED	DATE	APPROVED	DATE	APPROVED	DATE	APPROVED	DATE	APPROVED	16/02/06	DDB	22/6/06	RD	7/2/03	FAB	14/2/03	JWH	23 JAN 03	FAB	23 JAN 03	JWH	<table border="1"> <tr> <th>DATE</th> <th>APPROVED</th> <th>DATE</th> <th>APPROVED</th> <th>DATE</th> <th>APPROVED</th> <th>DATE</th> <th>APPROVED</th> <th>DATE</th> <th>APPROVED</th> <th>DATE</th> <th>APPROVED</th> </tr> <tr> <td>16/02/06</td> <td>DDB</td> <td>22/6/06</td> <td>RD</td> <td>7/2/03</td> <td>FAB</td> <td>14/2/03</td> <td>JWH</td> <td>23 JAN 03</td> <td>FAB</td> <td>23 JAN 03</td> <td>JWH</td> </tr> </table>	DATE	APPROVED	DATE	APPROVED	DATE	APPROVED	DATE	APPROVED	DATE	APPROVED	DATE	APPROVED	16/02/06	DDB	22/6/06	RD	7/2/03	FAB	14/2/03	JWH	23 JAN 03	FAB	23 JAN 03	JWH	<table border="1"> <tr> <th>DATE</th> <th>APPROVED</th> <th>DATE</th> <th>APPROVED</th> <th>DATE</th> <th>APPROVED</th> <th>DATE</th> <th>APPROVED</th> <th>DATE</th> <th>APPROVED</th> <th>DATE</th> <th>APPROVED</th> </tr> <tr> <td>16/02/06</td> <td>DDB</td> <td>22/6/06</td> <td>RD</td> <td>7/2/03</td> <td>FAB</td> <td>14/2/03</td> <td>JWH</td> <td>23 JAN 03</td> <td>FAB</td> <td>23 JAN 03</td> <td>JWH</td> </tr> </table>	DATE	APPROVED	DATE	APPROVED	DATE	APPROVED	DATE	APPROVED	DATE	APPROVED	DATE	APPROVED	16/02/06	DDB	22/6/06	RD	7/2/03	FAB	14/2/03	JWH	23 JAN 03	FAB	23 JAN 03	JWH	<table border="1"> <tr> <th>DATE</th> <th>APPROVED</th> <th>DATE</th> <th>APPROVED</th> <th>DATE</th> <th>APPROVED</th> <th>DATE</th> <th>APPROVED</th> <th>DATE</th> <th>APPROVED</th> <th>DATE</th> <th>APPROVED</th> </tr> <tr> <td>16/02/06</td> <td>DDB</td> <td>22/6/06</td> <td>RD</td> <td>7/2/03</td> <td>FAB</td> <td>14/2/03</td> <td>JWH</td> <td>23 JAN 03</td> <td>FAB</td> <td>23 JAN 03</td> <td>JWH</td> </tr> </table>	DATE	APPROVED	DATE	APPROVED	DATE	APPROVED	DATE	APPROVED	DATE	APPROVED	DATE	APPROVED	16/02/06	DDB	22/6/06	RD	7/2/03	FAB	14/2/03	JWH	23 JAN 03	FAB	23 JAN 03	JWH
DATE	APPROVED	DATE	APPROVED	DATE	APPROVED	DATE	APPROVED	DATE	APPROVED	DATE	APPROVED																																																																																																																																																																																																																																																																																																																									
16/02/06	DDB	22/6/06	RD	7/2/03	FAB	14/2/03	JWH	23 JAN 03	FAB	23 JAN 03	JWH																																																																																																																																																																																																																																																																																																																									
DATE	APPROVED	DATE	APPROVED	DATE	APPROVED	DATE	APPROVED	DATE	APPROVED	DATE	APPROVED																																																																																																																																																																																																																																																																																																																									
16/02/06	DDB	22/6/06	RD	7/2/03	FAB	14/2/03	JWH	23 JAN 03	FAB	23 JAN 03	JWH																																																																																																																																																																																																																																																																																																																									
DATE	APPROVED	DATE	APPROVED	DATE	APPROVED	DATE	APPROVED	DATE	APPROVED	DATE	APPROVED																																																																																																																																																																																																																																																																																																																									
16/02/06	DDB	22/6/06	RD	7/2/03	FAB	14/2/03	JWH	23 JAN 03	FAB	23 JAN 03	JWH																																																																																																																																																																																																																																																																																																																									
DATE	APPROVED	DATE	APPROVED	DATE	APPROVED	DATE	APPROVED	DATE	APPROVED	DATE	APPROVED																																																																																																																																																																																																																																																																																																																									
16/02/06	DDB	22/6/06	RD	7/2/03	FAB	14/2/03	JWH	23 JAN 03	FAB	23 JAN 03	JWH																																																																																																																																																																																																																																																																																																																									
DATE	APPROVED	DATE	APPROVED	DATE	APPROVED	DATE	APPROVED	DATE	APPROVED	DATE	APPROVED																																																																																																																																																																																																																																																																																																																									
16/02/06	DDB	22/6/06	RD	7/2/03	FAB	14/2/03	JWH	23 JAN 03	FAB	23 JAN 03	JWH																																																																																																																																																																																																																																																																																																																									
DATE	APPROVED	DATE	APPROVED	DATE	APPROVED	DATE	APPROVED	DATE	APPROVED	DATE	APPROVED																																																																																																																																																																																																																																																																																																																									
16/02/06	DDB	22/6/06	RD	7/2/03	FAB	14/2/03	JWH	23 JAN 03	FAB	23 JAN 03	JWH																																																																																																																																																																																																																																																																																																																									
DATE	APPROVED	DATE	APPROVED	DATE	APPROVED	DATE	APPROVED	DATE	APPROVED	DATE	APPROVED																																																																																																																																																																																																																																																																																																																									
16/02/06	DDB	22/6/06	RD	7/2/03	FAB	14/2/03	JWH	23 JAN 03	FAB	23 JAN 03	JWH																																																																																																																																																																																																																																																																																																																									
DATE	APPROVED	DATE	APPROVED	DATE	APPROVED	DATE	APPROVED	DATE	APPROVED	DATE	APPROVED																																																																																																																																																																																																																																																																																																																									
16/02/06	DDB	22/6/06	RD	7/2/03	FAB	14/2/03	JWH	23 JAN 03	FAB	23 JAN 03	JWH																																																																																																																																																																																																																																																																																																																									
DATE	APPROVED	DATE	APPROVED	DATE	APPROVED	DATE	APPROVED	DATE	APPROVED	DATE	APPROVED																																																																																																																																																																																																																																																																																																																									
16/02/06	DDB	22/6/06	RD	7/2/03	FAB	14/2/03	JWH	23 JAN 03	FAB	23 JAN 03	JWH																																																																																																																																																																																																																																																																																																																									
DATE	APPROVED	DATE	APPROVED	DATE	APPROVED	DATE	APPROVED	DATE	APPROVED	DATE	APPROVED																																																																																																																																																																																																																																																																																																																									
16/02/06	DDB	22/6/06	RD	7/2/03	FAB	14/2/03	JWH	23 JAN 03	FAB	23 JAN 03	JWH																																																																																																																																																																																																																																																																																																																									
DATE	APPROVED	DATE	APPROVED	DATE	APPROVED	DATE	APPROVED	DATE	APPROVED	DATE	APPROVED																																																																																																																																																																																																																																																																																																																									
16/02/06	DDB	22/6/06	RD	7/2/03	FAB	14/2/03	JWH	23 JAN 03	FAB	23 JAN 03	JWH																																																																																																																																																																																																																																																																																																																									
DATE	APPROVED	DATE	APPROVED	DATE	APPROVED	DATE	APPROVED	DATE	APPROVED	DATE	APPROVED																																																																																																																																																																																																																																																																																																																									
16/02/06	DDB	22/6/06	RD	7/2/03	FAB	14/2/03	JWH	23 JAN 03	FAB	23 JAN 03	JWH																																																																																																																																																																																																																																																																																																																									
DATE	APPROVED	DATE	APPROVED	DATE	APPROVED	DATE	APPROVED	DATE	APPROVED	DATE	APPROVED																																																																																																																																																																																																																																																																																																																									
16/02/06	DDB	22/6/06	RD	7/2/03	FAB	14/2/03	JWH	23 JAN 03	FAB	23 JAN 03	JWH																																																																																																																																																																																																																																																																																																																									
<p>DO NOT SCALE IF IN DOUBT - ASK</p>	<p>THIRD ANGLE DRAWING TO BS 8888 KEY SYMBOLS TO BS 4142 SURFACE TEXTURE TO BS 1370 MATERIAL & CONDITION BEFORE MANUFACTURE</p>	<p>SOUTH AFRICAN PORT OPERATIONS IRON ORE TERMINAL - SALDANHA STACKER RECLAIMER CONTRACT HQH375 SANCTION No. SB01 D1</p>	<p>METSO MINERALS (UK) LTD BULK MATERIALS HANDLING BRISTOL PO BOX 821 ASHTON VALE RD BRISTOL BS39 5ZB ENGLAND</p>																																																																																																																																																																																																																																																																																																																																	
<p>ASSY AND DETAIL OF SLEW RING AND SLEW DRIVES</p>	<p>TITLE</p>	<p>ORIGINAL SCALE</p>	<p>SIZE DRAWING NUMBER</p>																																																																																																																																																																																																																																																																																																																																	
<p>SEE SHT 1</p>	<p>1:10</p>	<p>A1</p>	<p>700422</p>																																																																																																																																																																																																																																																																																																																																	
<p>SHEET 2</p>	<p>OF 5</p>	<p>ISSUE E</p>	<p>DATE</p>																																																																																																																																																																																																																																																																																																																																	

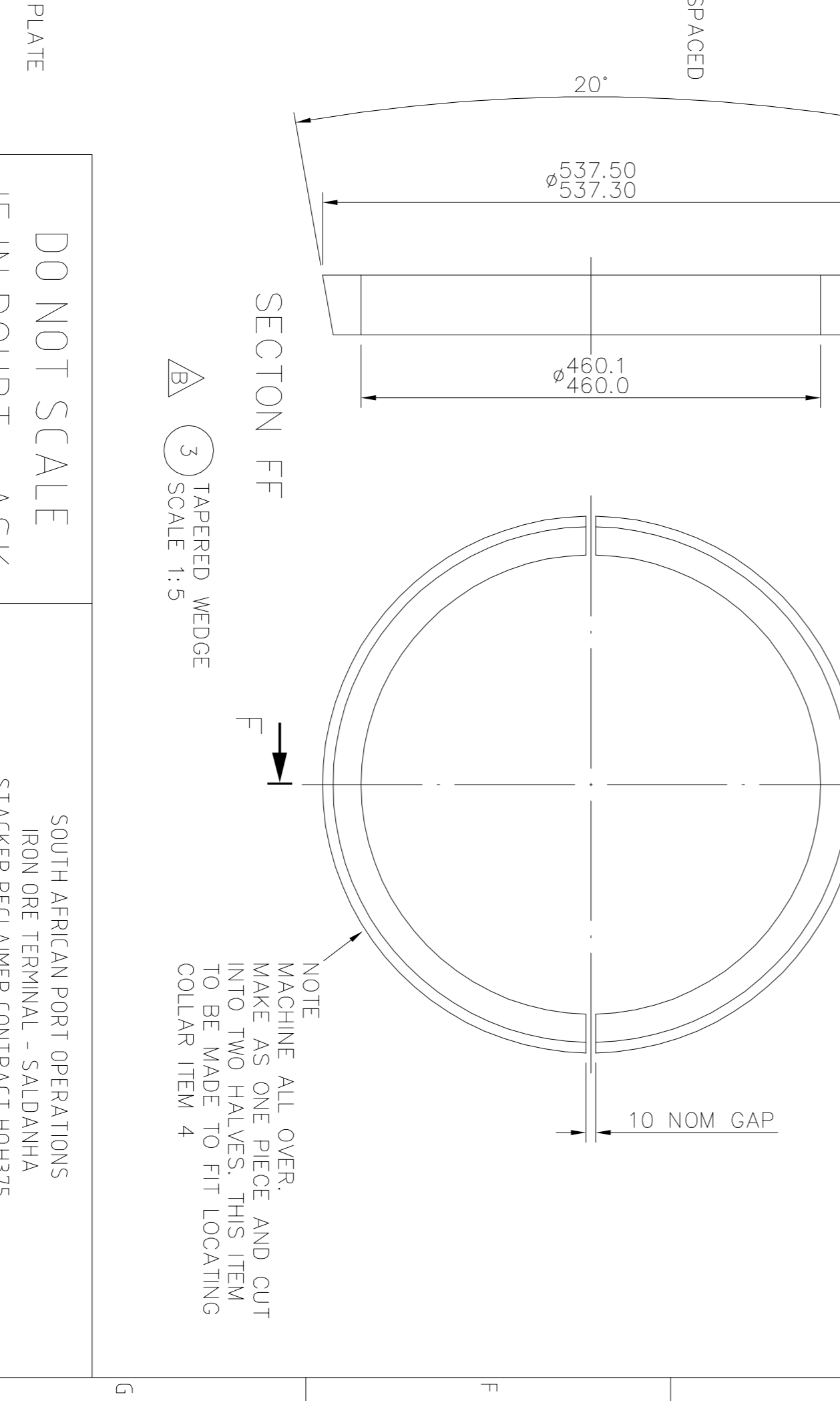
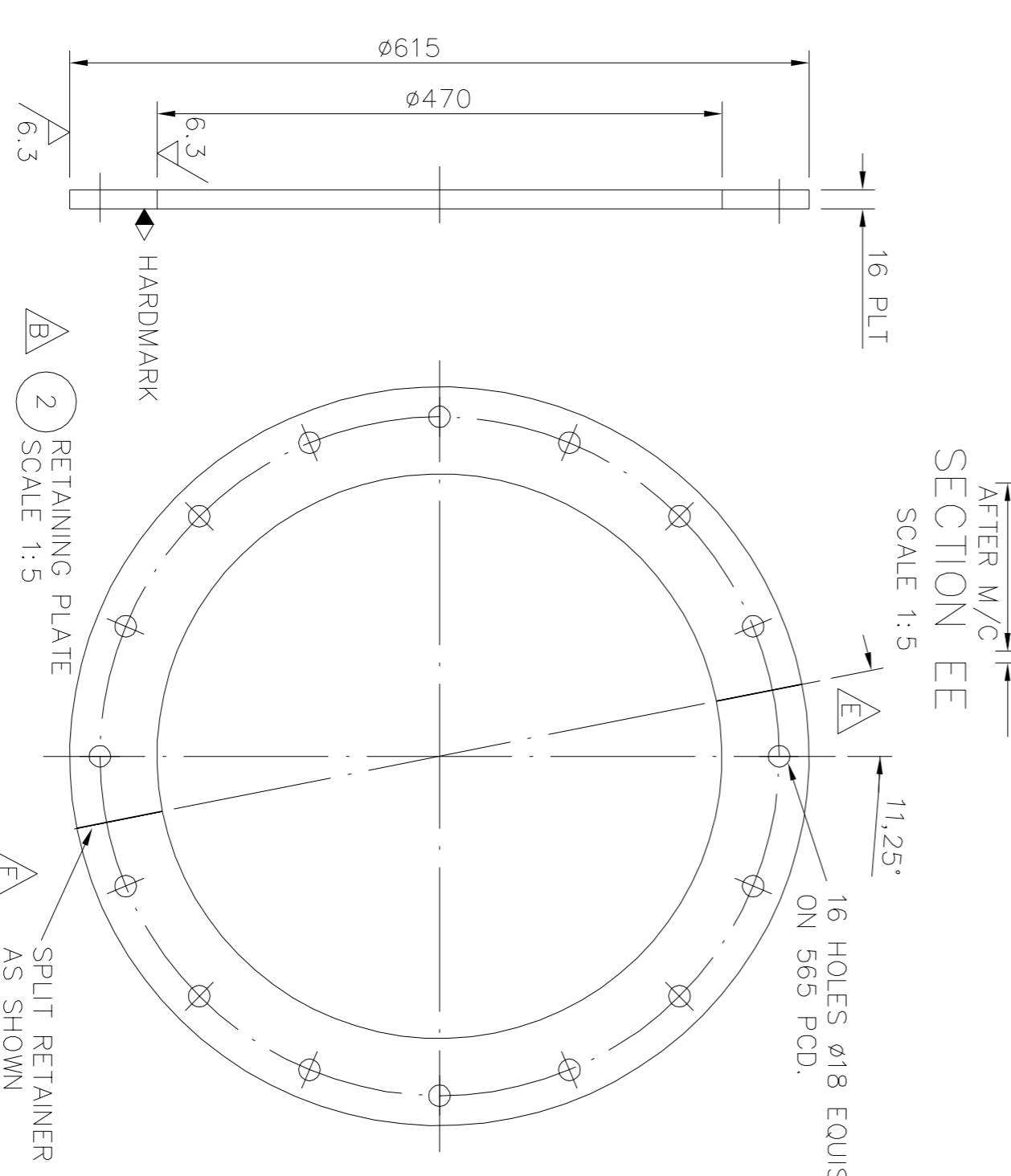
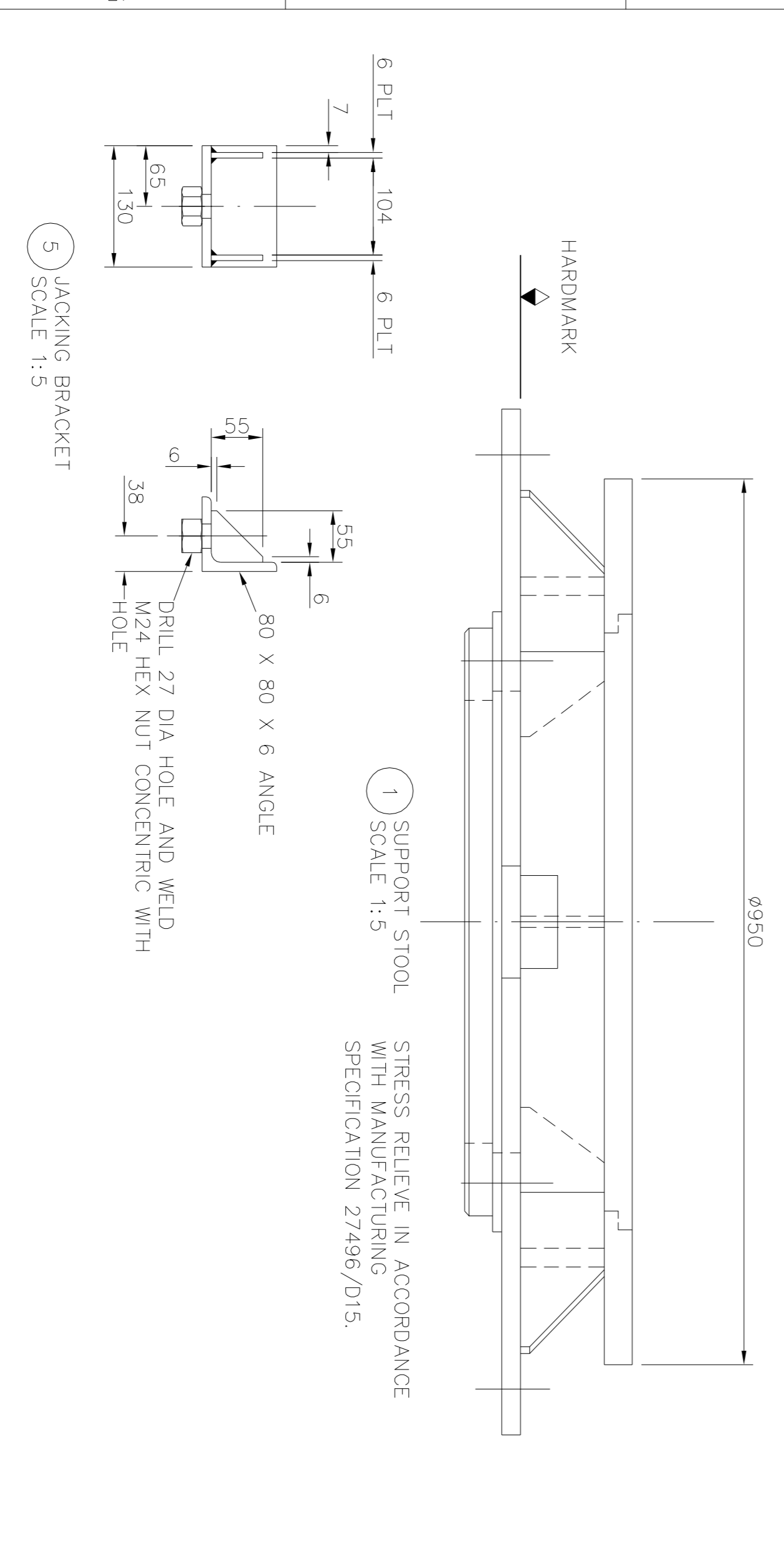
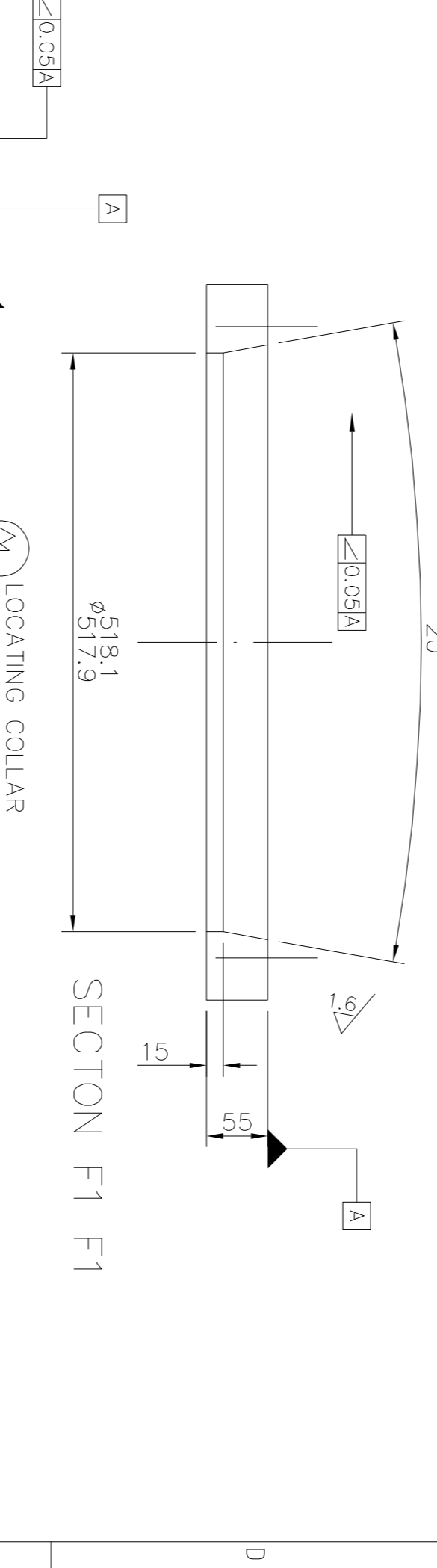
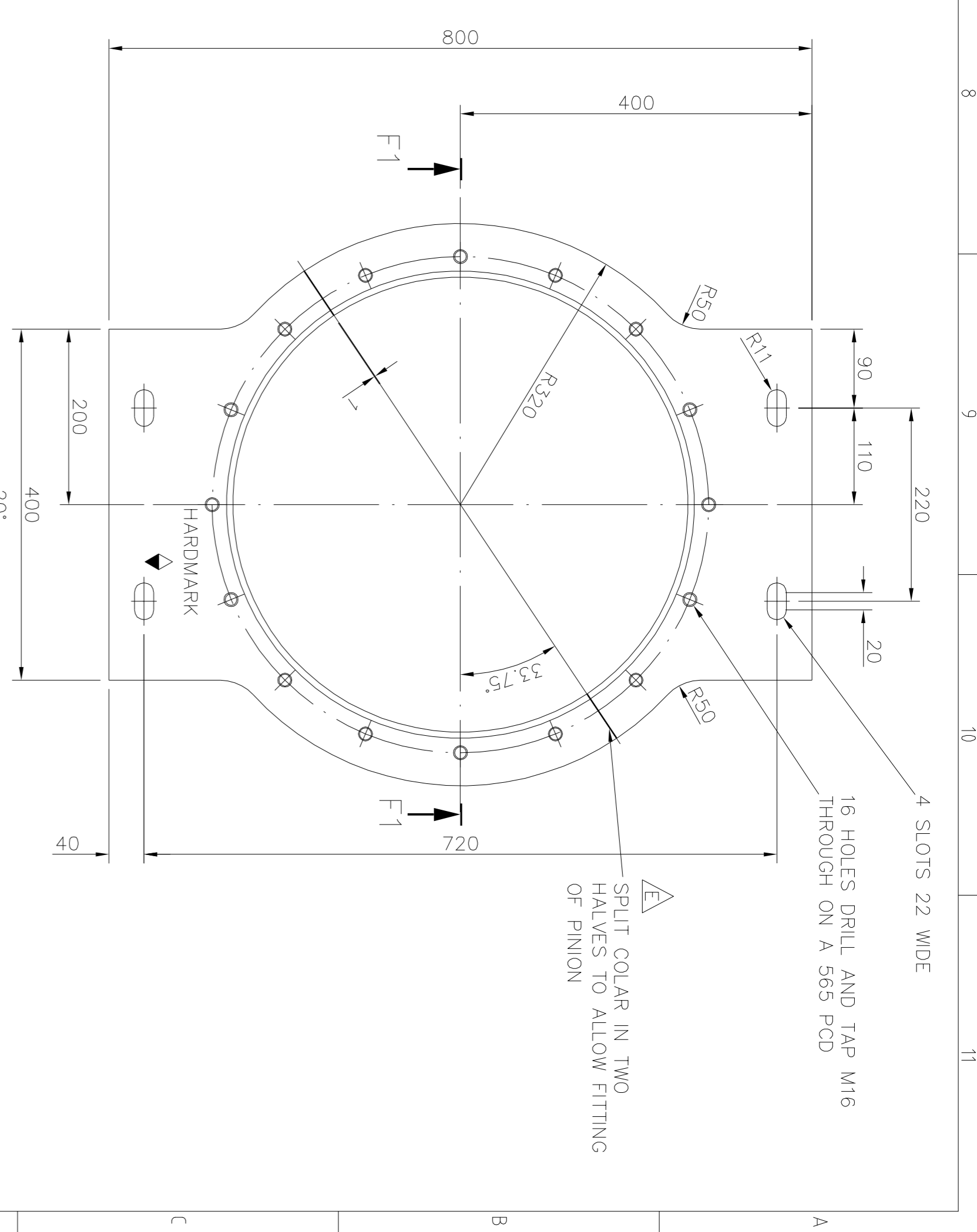
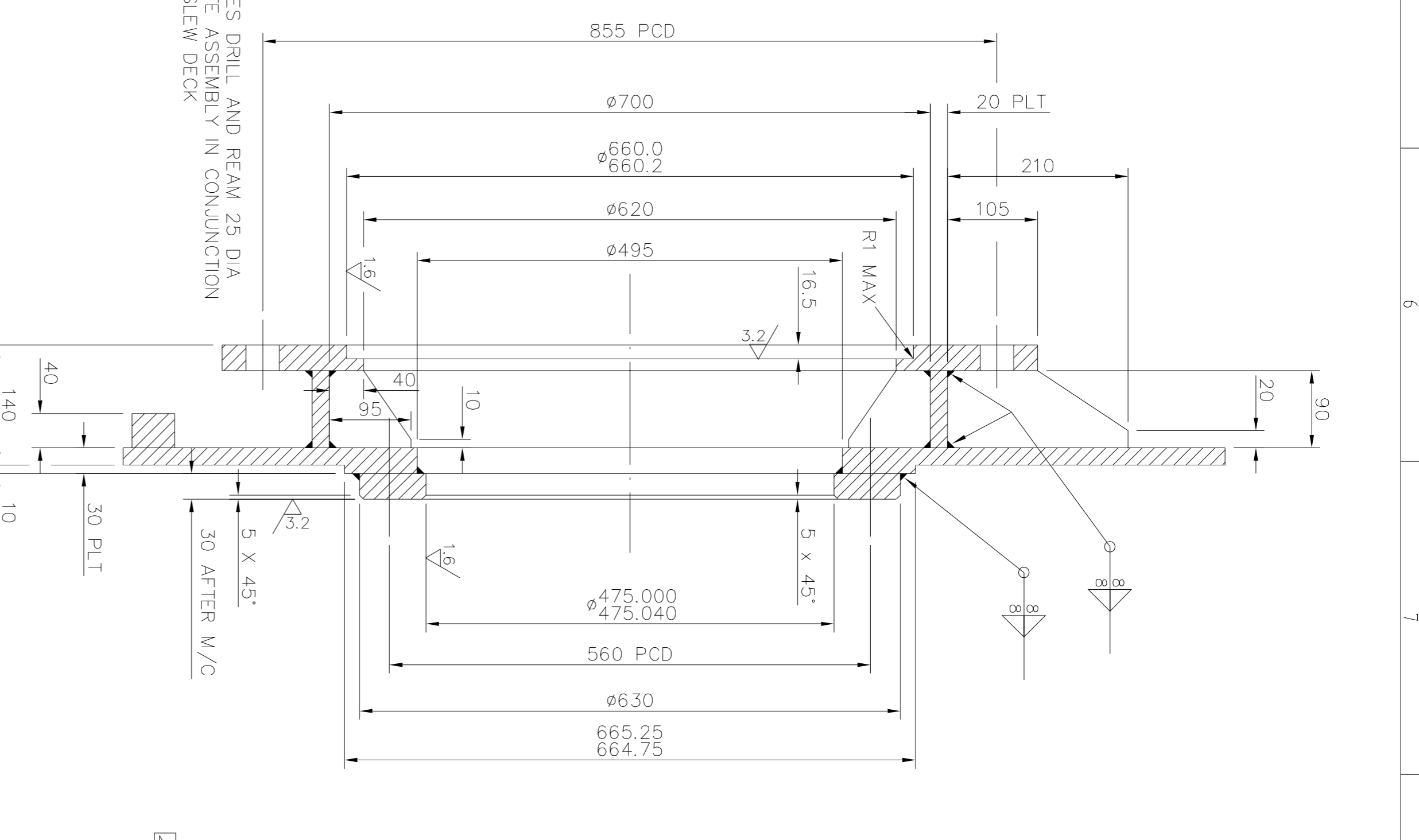
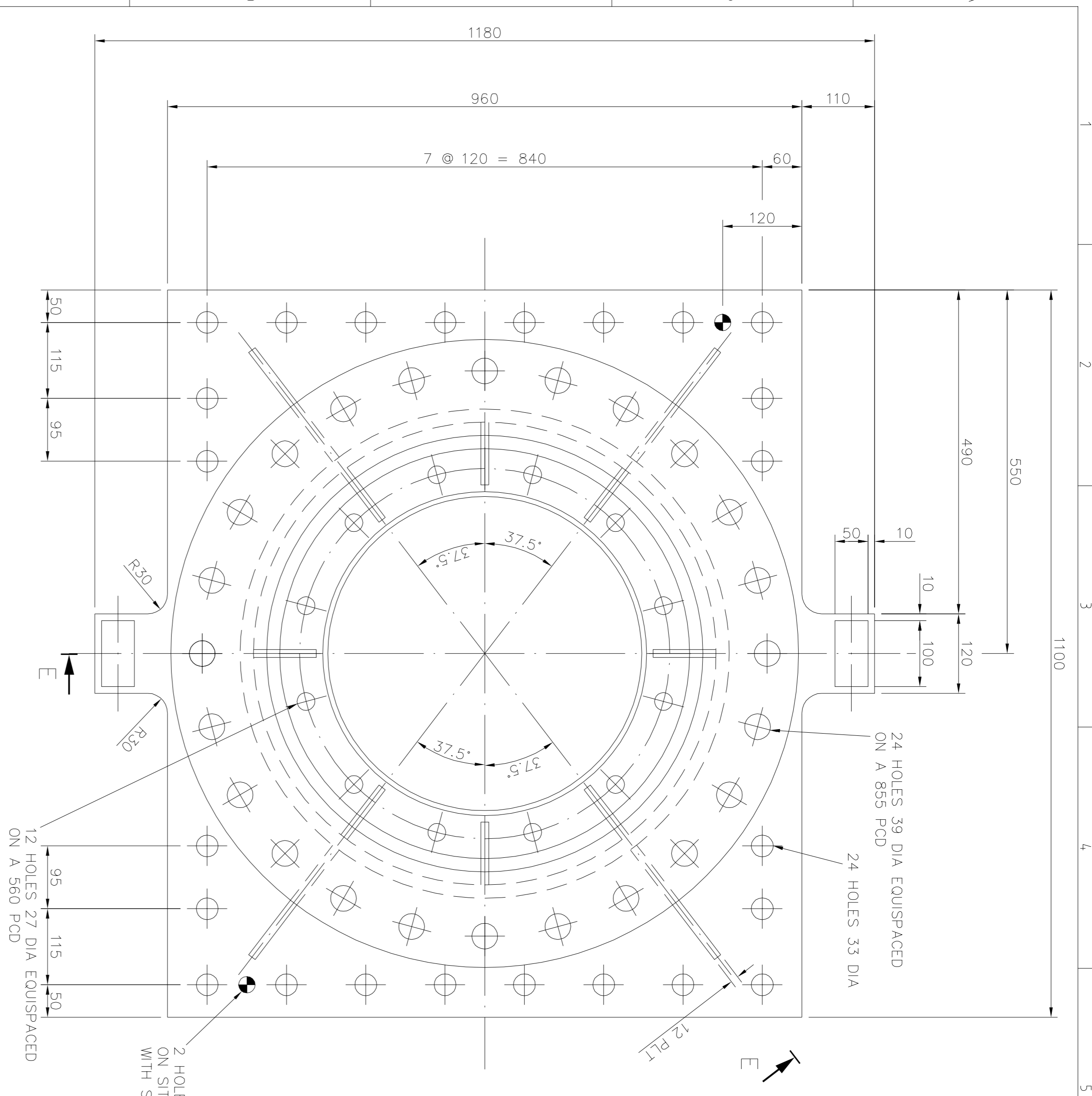

DATE	DRAWN	CHECKED	DATE	DRAWN	CHECKED	DATE	DRAWN	CHECKED	DATE	DRAWN	CHECKED
16/02/06	DD3	DD3	16/02/06	FAB	JWH	14/2/03	FAB	JWH	23 JAN 03	FAB	23 JAN 03
22/6/06	RD	JWH	22/6/06	FAB	JWH	14/2/03	FAB	JWH	23 JAN 03	FAB	23 JAN 03
7/2/03	DD3	DD3	7/2/03	FAB	JWH	14/2/03	FAB	JWH	23 JAN 03	FAB	23 JAN 03
14/2/03	DD3	DD3	14/2/03	FAB	JWH	14/2/03	FAB	JWH	23 JAN 03	FAB	23 JAN 03
16/02/06	DD3	DD3	16/02/06	FAB	JWH	14/2/03	FAB	JWH	23 JAN 03	FAB	23 JAN 03

ISSUES RAISED
ITEM 2
AS BUILT

SEE SHT 1, 3 AND 5

SEE SHEET 3

ITEM 2,3 AND 4 REVISED

ISSUED FOR MANUFACTURE

UNLESS OTHERWISE SPECIFIED IDENTIFY THE ITEM WITH THE DRAWING NUMBER AND ISSUE LEVEL AT ▲ AND IN THE MANNER SHOWN FOR PAINTING AND FOR LUBRICATION SPECIFICATIONS SEE COMPONENTS LIST.

TOLERANCES UNLESS OTHERWISE STATED (PLUS OR MINUS)
RANGE MACH FAB CAST
0-500 0.25 2 2
501-1000 0.5 3 3
1001-2000 1 4 4
ABOVE 2000 2.0 6 6

THIS PRINT AND ALL THE INFORMATION HEREON IS THE PROPERTY OF METSO MINERALS. BULK MATERIALS HANDLING BRISTOL. IT IS LOANED SUBJECT TO THE CONDITION OF THE CONTRACT AND MUST NOT BE REPRODUCED OR COPIED IN ANY MANNER WITHOUT THE WRITTEN PERMISSION OF METSO MINERALS. FOR RETURN ON DEMAND, UNLESS TURNS UNDER CONTRACT PROVISIONS.

DO NOT SCALE
IF IN DOUBT - ASK

metso minerals

SOUTH AFRICAN PORT OPERATIONS
IRON ORE TERMINAL - SALDANHA
STACKER RECLAIMER CONTRACT HQH375
SANCTION No. SB01 D1

METSO MINERALS (UK) LTD
BULK MATERIALS HANDLING BRISTOL
PO BOX 921 ASHTON VALE RD
BRISTOL BS99 5ZB ENGLAND

TITLE
ASSY AND DETAIL OF
SLEW RING AND SLEW DRIVES

MASS
SEE SHT 1

ORIGINAL SCALE
1:5

SIZE
DRAWING NUMBER
A1
700422

SHEET
OF
ISSUE
4
5
E

ELEVATOR AND TRIPPER THIS SIDE

THE UNHARDENED ZONE (SOFT SPOT) OF THE RACEWAY AND GEAR RING IDENTIFIED BY 'S' STAMPED ON THE RACEWAY AND GEAR RING TO BE POSITION HERE
NOTE: ROTATE SOFT SPOT 20mm CLOCKWISE TO ENSURE FOULING OF JACKING BOLTS WITH BEARING BOLTS

SUPERSTRUCTURE CG ANGULAR MOVEMENT DURING RECLAIMING IN THE FRONT AND REAR QUADRANT (REF)

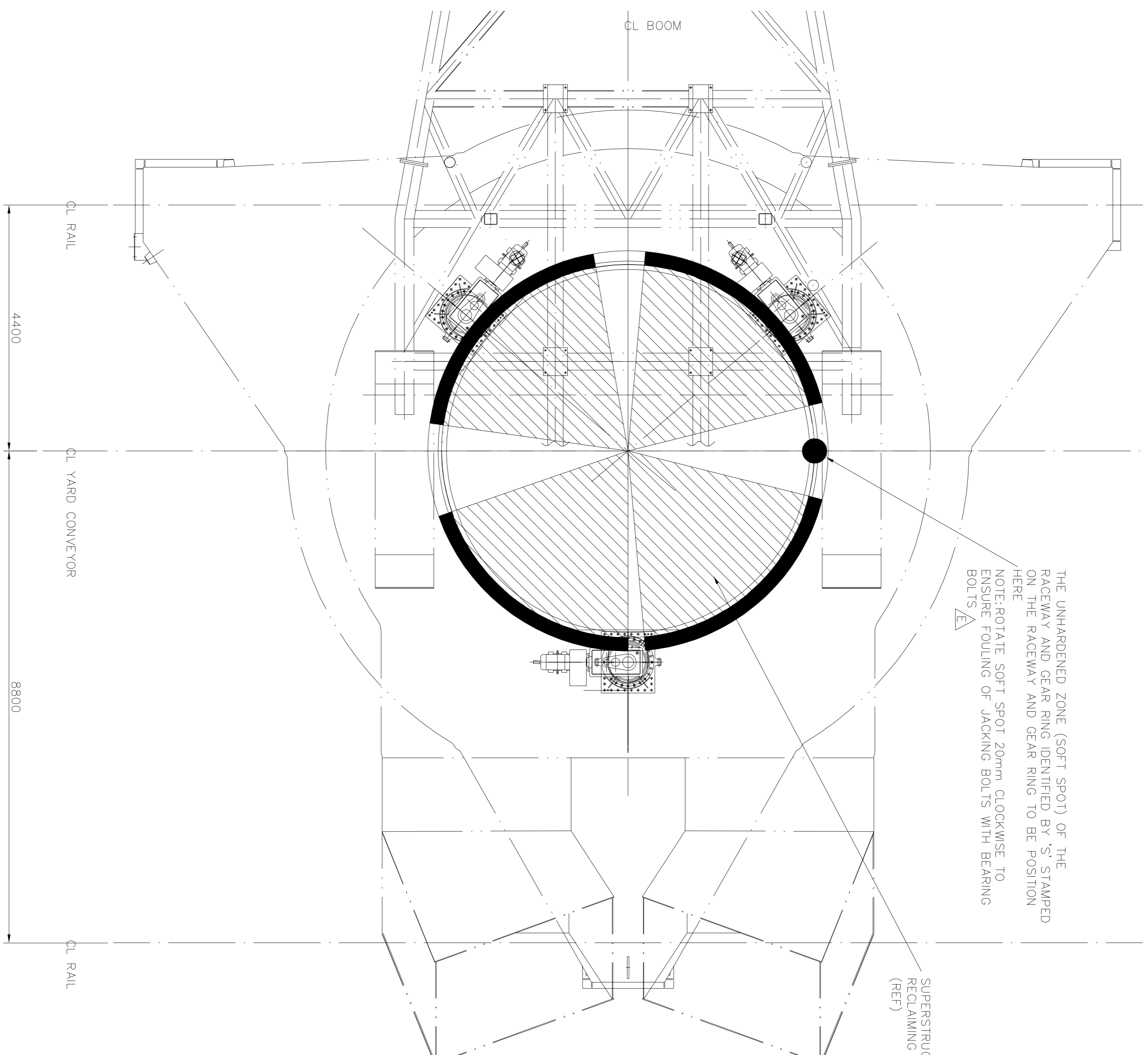

PLAN VIEW OF BASE FRAME AND SLEW DECK DURING ERECTION WITH BOOM POSITIONED ON ERECTION TRESTLE

ISSUES RAISED ROTATE SOFT SPOT 20mm CLOCKWISE TO ENSURE NO FOULING OF BOLTS AS BUILT		ISSUED FOR MANUFACTURE DRAWN: USB DATE: OCT 02 CHECKED: FAB DATE: 27/11/02 APPROVED: JWH DATE: 03/12/02	
SHEET 5 ADDED. SEE SHT 1 AND 3.		ISSUED FOR MANUFACTURE DRAWN: FAB DATE: 5/12/02 CHECKED: JWH DATE: 6/12/02 APPROVED: JWH DATE: 6/12/02	
SEE SHEET 3		ISSUED FOR MANUFACTURE DRAWN: FAB DATE: 23 JAN 03 CHECKED: FAB DATE: 23 JAN 03 APPROVED: FAB DATE: 23 JAN 03	
SEE SHEET 3		ISSUED FOR MANUFACTURE DRAWN: FAB DATE: 7/2/03 CHECKED: JWH DATE: 14/2/03 APPROVED: JWH DATE: 14/2/03	
ISSUES RAISED ROTATE SOFT SPOT 20mm CLOCKWISE TO ENSURE NO FOULING OF BOLTS AS BUILT		ISSUED FOR MANUFACTURE DRAWN: DDB DATE: 16/02/06 CHECKED: RD DATE: 22/6/06 APPROVED: JWH DATE: 22/6/06	
DRAWN DATE	CHECKED DATE	APPROVED DATE	DRAWN DATE
DATE 16/02/06	DATE 22/6/06	DATE 22/6/06	DATE 16/02/06

DO NOT SCALE
IF IN DOUBT - ASK

metso minerals

SOUTH AFRICAN PORT OPERATIONS
 IRON ORE TERMINAL - SALDANHA
 STACKER RECLAIMER CONTRACT HQH375
 SANCTION No. SB01 D1

METSO MINERALS (UK LTD)
 BULK MATERIALS HANDLING BRISTOL
 PO BOX 821 ASHTON VALE RD
 BRISTOL BS399 5ZB ENGLAND

ASSY AND DETAIL OF
 SLEW RING AND SLEW DRIVES

700422

DRAWN TO BS 8888 METSO SYMBOLS TO BS 8888 SURFACE TEXTURE TO BS 1314 MATERIAL & CONDITION BEFORE MANUFACTURE	THIRD ANGLE 	ORIGINAL SCALE 1:50	SIZE A1	DRAWING NUMBER 700422	SHEET OF 5	ISSUE 5 E
THIS PRINT AND ALL THE INFORMATION HEREIN IS THE PROPERTY OF METSO MINERALS. BULK MATERIALS HANDLING BRISTOL AND MUST NOT BE MADE PUBLIC, COPIED OR USED IN ANY WAY DETRIMENTAL TO OUR INTEREST. IT IS LOANED SUBJECT TO RETURN ON DEMAND UNLESS FURNISHED UNDER CONTRACT PROVISIONS.	UNLESS OTHERWISE SPECIFIED IDENTIFY THE ITEM WITH THE DRAWING NUMBER AND ISSUE LEVEL AT THE MANNER SHOWN FOR PAINTING AND FOR LUBRICATION SPECIFICATIONS SEE COMPONENTS LIST. TOLERANCES UNLESS OTHERWISE STATED (PLUS OR MINUS) RANGE MILLIMETRES 0-500 0.25 501-1000 0.5 1001-2000 1.0 ABOVE 2000 2.0 MACH 2 FAB 3 CAST 4 6 10	GRADE NOTES	SPEC MASS SEE SHT 1	TITLE ASSY AND DETAIL OF SLEW RING AND SLEW DRIVES	DATE 16/02/06	DATE 22/6/06

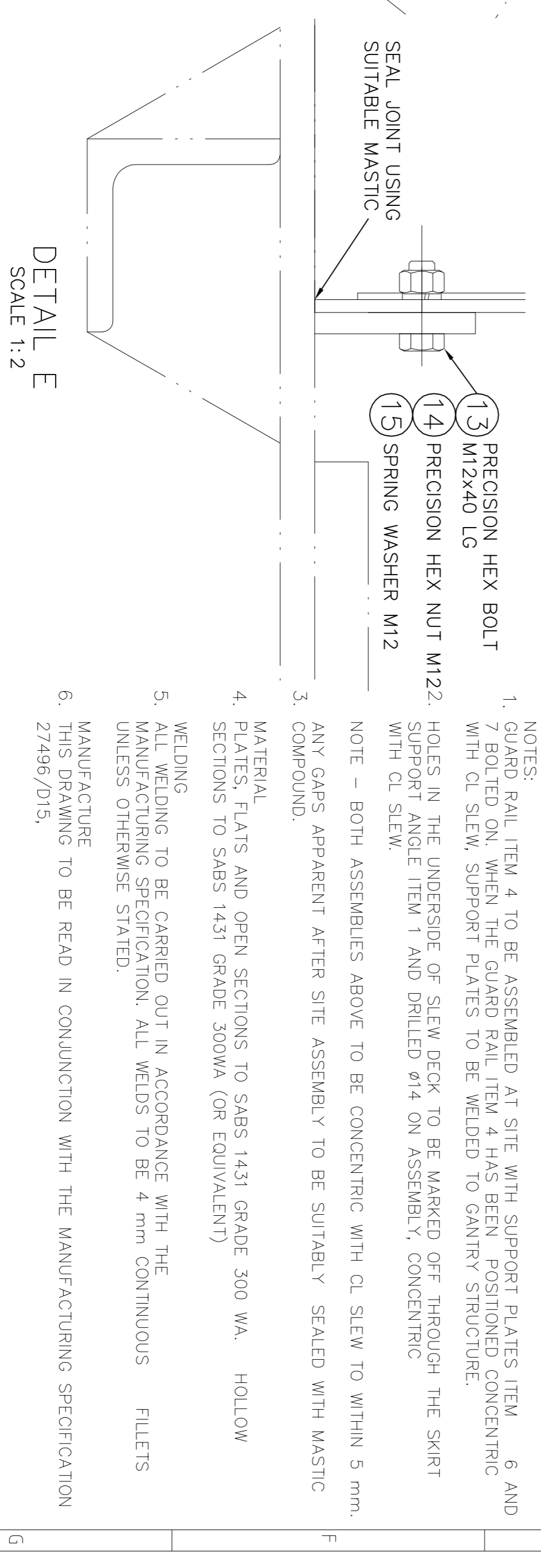
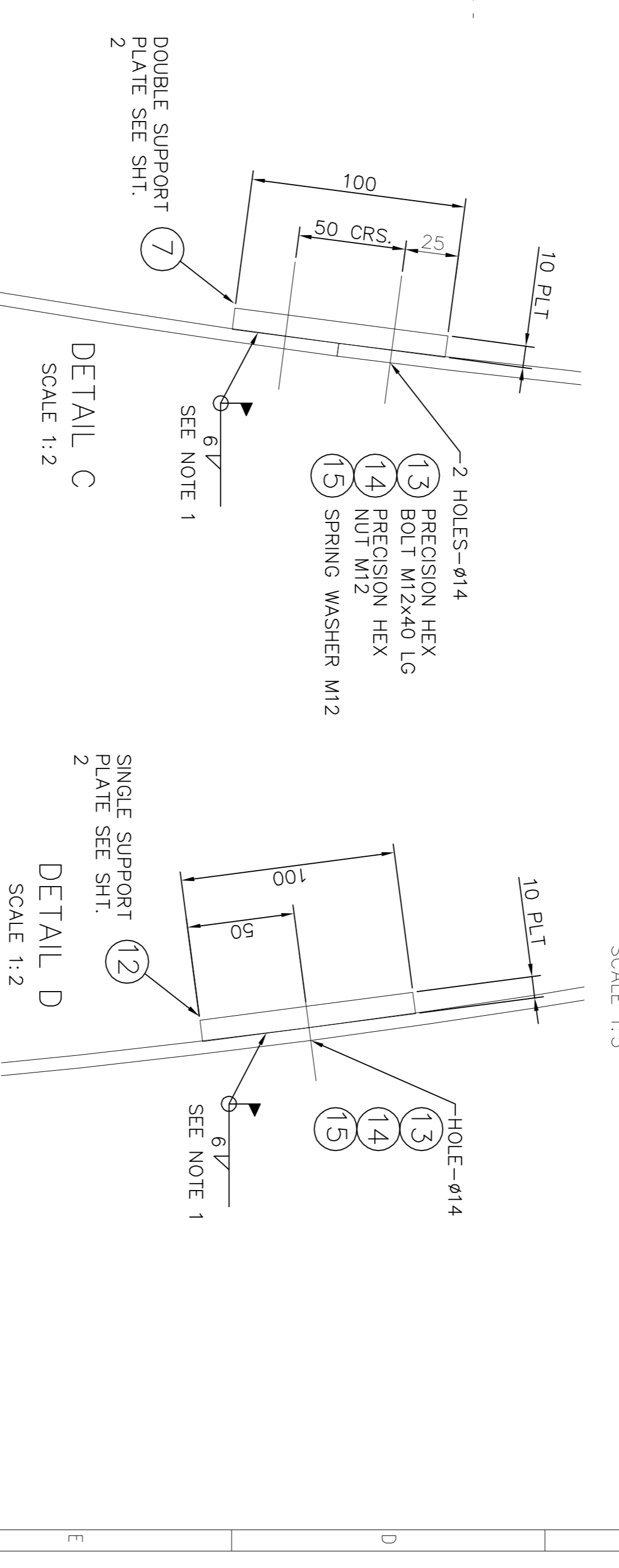
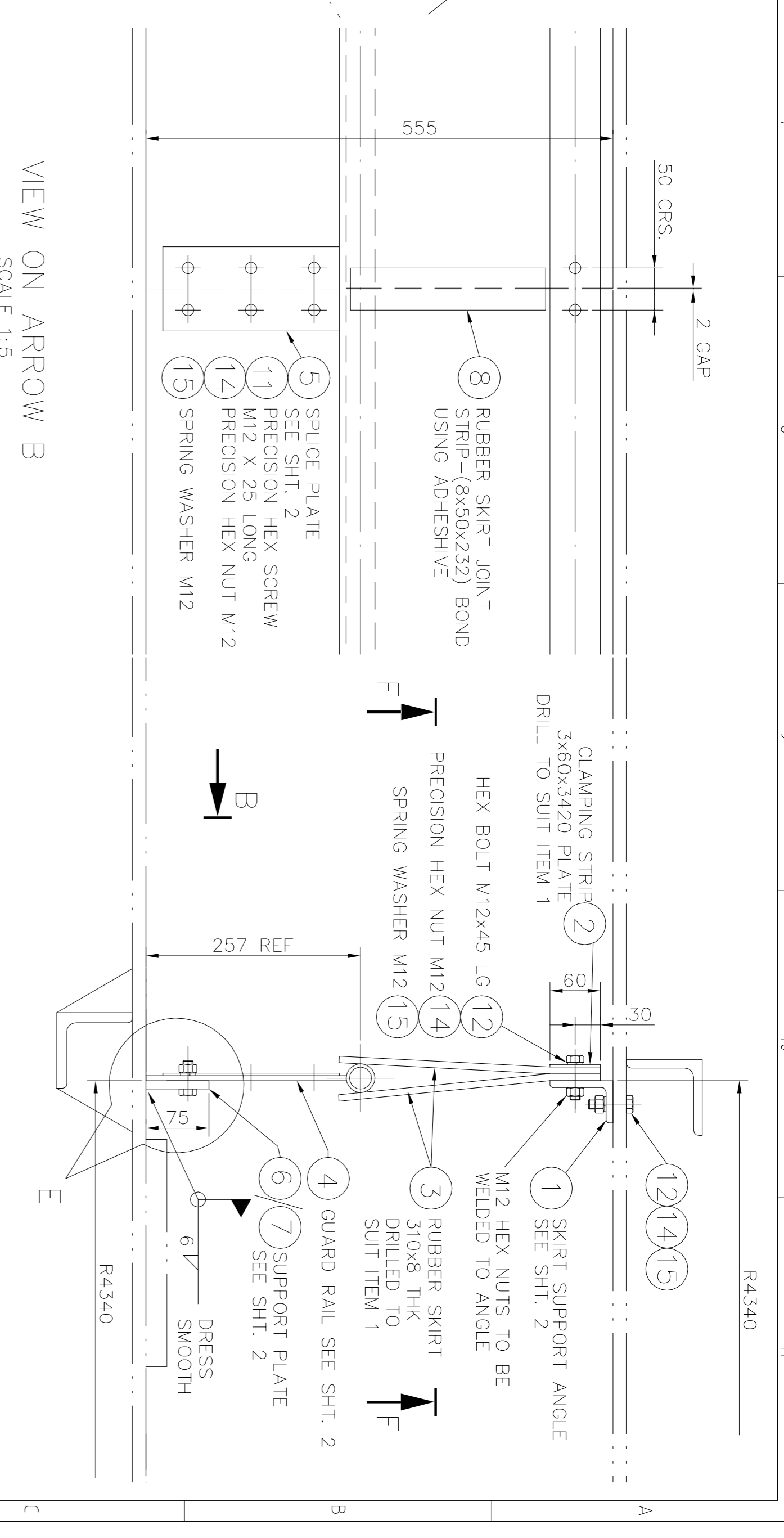
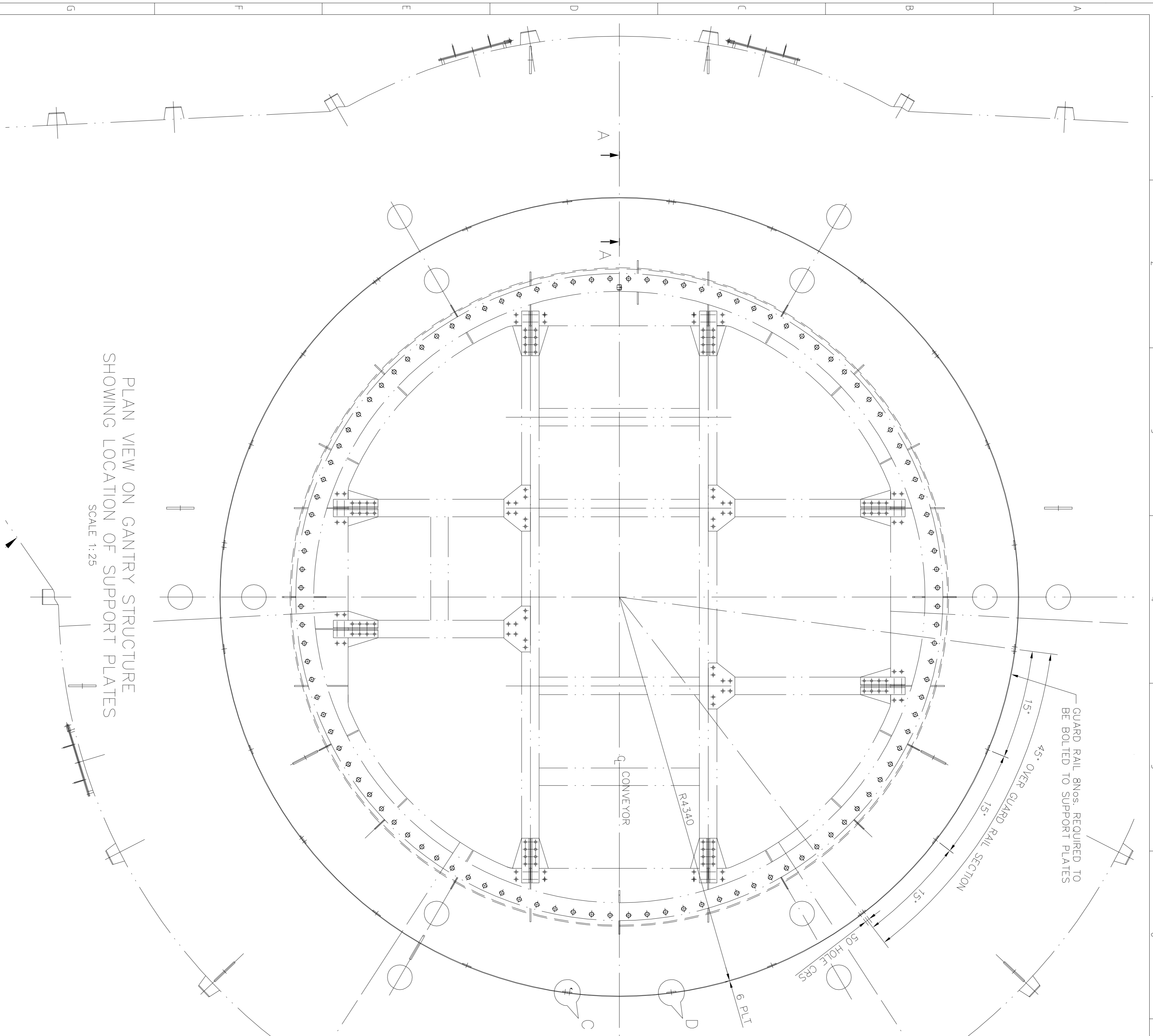

**DO NOT SCALE
IF IN DOUBT - ASK**

SOUTH AFRICAN PORT OPERATIONS
IRON ORE TERMINAL - SALDANHA
STACKER RECLAIMER CONTRACT HQH375
SANCTION NO. SB01 D1

METSO MINERALS (UK) LTD
BULK MATERIALS HANDLING BRISTOL
PO BOX 821 ASHTON VALE RD
BRISTOL BS599 5ZB ENGLAND

UNLESS OTHERWISE SPECIFIED IDENTIFY THE ITEM WITH THE DRAWING NUMBER AND ISSUE LEVEL AT \blacktriangledown AND IN THE MANNER SHOWN FOR PAINTING AND FOR LUBRICATION SPECIFICATIONS SEE COMPONENTS LIST.

UNLESS OTHERWISE STATED DIMENSIONS ARE IN MILLIMETRES

TOLERANCES UNLESS OTHERWISE STATED (PLUS OR MINUS)	RANGE	MACH	FAB	CAST
	0-500	0.25	2	4
	501-1000	0.5	3	6
	1001-2000	1.0	4	10
	ABOVE 2000	2.0	6	15

This print and all the information hereon is the property of Metso Minerals. Bulk Materials Handling Bristol and must not be made public, copied or used in any way detrimental to our interests. It is loaned subject to return on demand unless furnished under contract provisions.

DRAWN TO BS 8888	THIRD ANGLE	WELDED SYMBOLS TO BS EN 2553	ANGLE
DRAWN TO BS 8888	THIRD ANGLE	WELDED SYMBOLS TO BS EN 2553	ANGLE
SURFACE TOLERANCE TO BS EN 1821			
MATERIAL & CONDITION BEFORE MANUFACTURE			
MATL	STEEL		
SPEC	SABS 1431		
GRADE	300WA UOS		
MASS	764 kg	ORIGINAL SCALE	1:25
		SIZE	DRAWING NUMBER
		A1	700425
SHEET OF	1	SHEET OF	2
ISSUE	B	ISSUE	B

DRAWN		CHECKED		APPROVED		DRAWN		CHECKED		APPROVED	
DATE	DATE	DATE	DATE	DATE	DATE	DATE	DATE	DATE	DATE	DATE	DATE
ISSUES RAISED GENUINE UPDATE		AS BUILT		ISSUED FOR MANUFACTURE		DRAWN DDB		CHECKED RD		APPROVED JWH	
DATE 22.03.06		DATE 22.03.06		DATE 28.10.02		DATE 22.03.06		DATE 22.03.06		DATE 28.10.02	

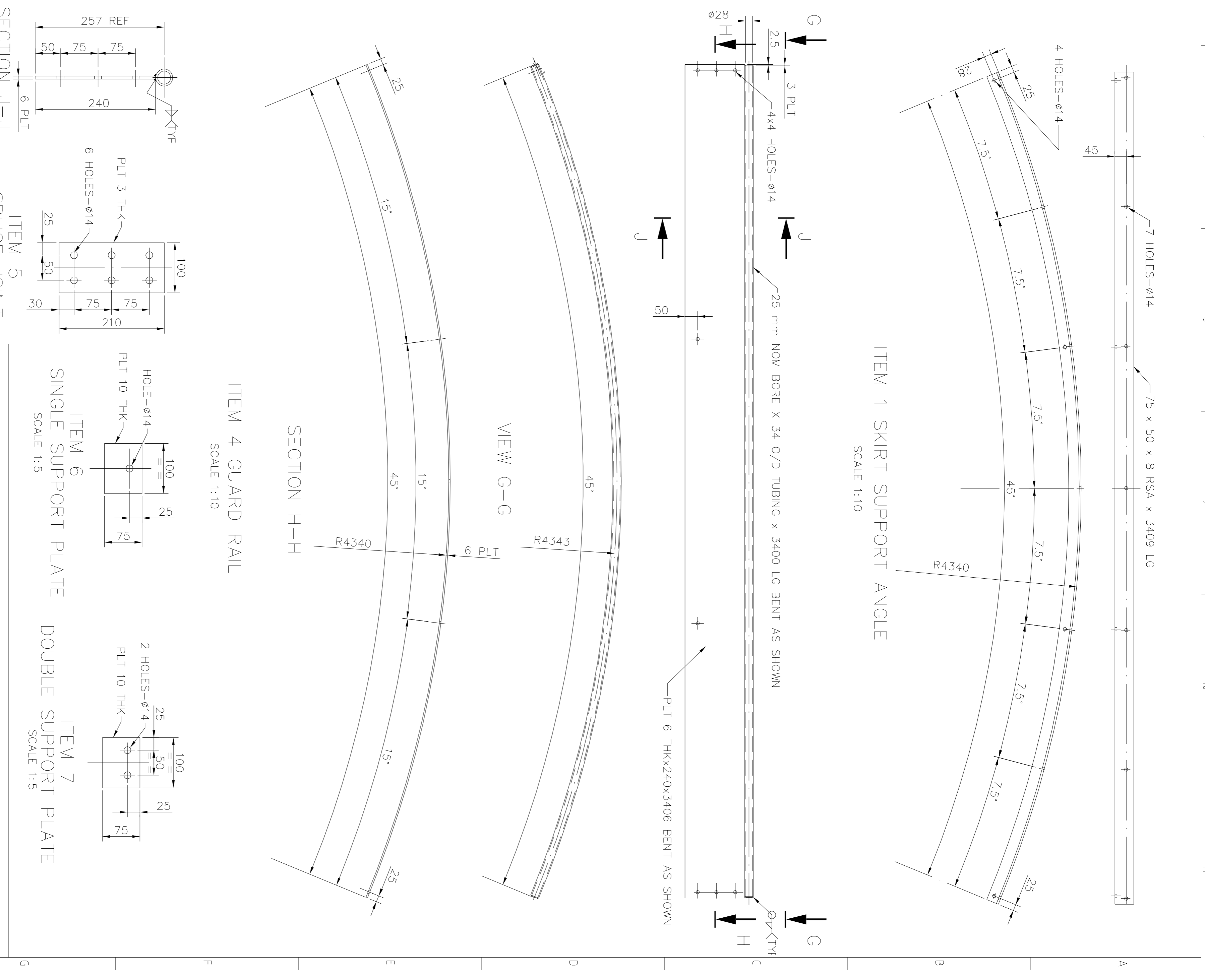
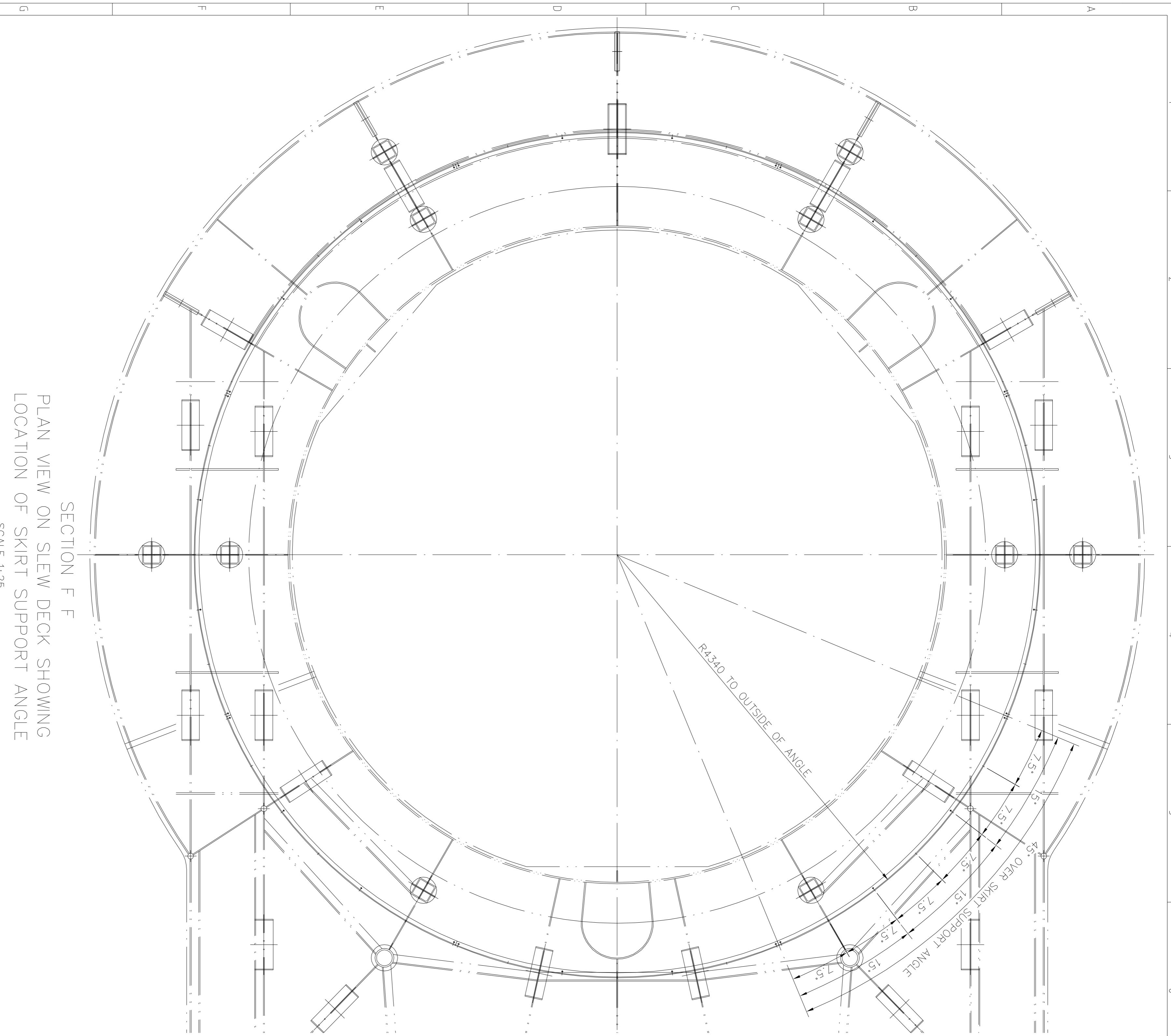

SECTION F F
 PLAN VIEW ON SLEW DECK SHOWING
 LOCATION OF SKIRT SUPPORT ANGLE
 SCALE 1:25

SECTION J-J
 SCALE 1:5

ITEM 5
 SPLICE JOINT
 SCALE 1:5

ITEM 6
 SINGLE SUPPORT PLATE
 SCALE 1:5

ITEM 7
 DOUBLE SUPPORT PLATE
 SCALE 1:5

ITEM 4 GUARD RAIL
 SCALE 1:10

SECTION H-H
 SCALE 1:5

ITEM 1 SKIRT SUPPORT ANGLE
 SCALE 1:10

ISSUES RAISED GEN UPDATE
 AS BUILT

ISSUED FOR MANUFACTURE

UNLESS OTHERWISE SPECIFIED IDENTIFY THE ITEM WITH THE DRAWING NUMBER AND ISSUE LEVEL AT AND IN THE MANNER SHOWN FOR PAINTING AND FOR LUBRICATION SPECIFICATIONS SEE COMPONENTS LIST.

UNLESS OTHERWISE STATED DIMENSIONS ARE IN MILLIMETRES TOLERANCES UNLESS OTHERWISE STATED (PLUS OR MINUS) RANGE MACH FAB CAST ABOVE 2000

This print and all the information herein is the property of Metso Minerals. Bulk Materials Handling Bristol and must not be made public, copied or used in any way detrimental to our interest. It is loaned subject to return on demand unless furnished under contract provisions.

DO NOT SCALE
 IF IN DOUBT - ASK

metso
 minerals

SOUTH AFRICAN PORT OPERATIONS
 IRON ORE TERMINAL - SALDANHA
 STACKER RECLAIMER CONTRACT HQH375
 SANCTION No. SB01 D1

METSO MINERALS (UK) LTD
 BULK MATERIALS HANDLING BRISTOL
 PO BOX 821 ASHTON VALE RD
 BRISTOL BS399 5ZB ENGLAND

ASSEMBLY AND DETAILS OF
 SLEW RING GUARD

DRAWN TO BS 8888 THIRD ANGLE
 WELD SYMBOLS TO BS EN 22543 ANGLE
 SURFACE TEXTURE TO BS EN 1997-1
 MATERIAL & CONDITION BEFORE MANUFACTURE

MAINT SEE SHEET 1
 SPEC SEE SHEET 1
 GRADE SEE SHEET 1
 NOTES SEE SHEET 1

ORIGINAL SCALE 1:25
 SIZE DRAWING NUMBER A1 700425

SHEET 2 OF 2
 ISSUE B

DATE	CHECKED	DATE	APPROVED	DATE	APPROVED	DATE	APPROVED	DATE	APPROVED	DATE	APPROVED	DATE	APPROVED
22.03.06	DDB	22.03.06	RD	22.6.06	JWH	28.10.02	USB	27.11.02	NCN	03.12.02	JWH		

1 2 3 4 5 6 7 8 9 10 11

H G F E D C B A

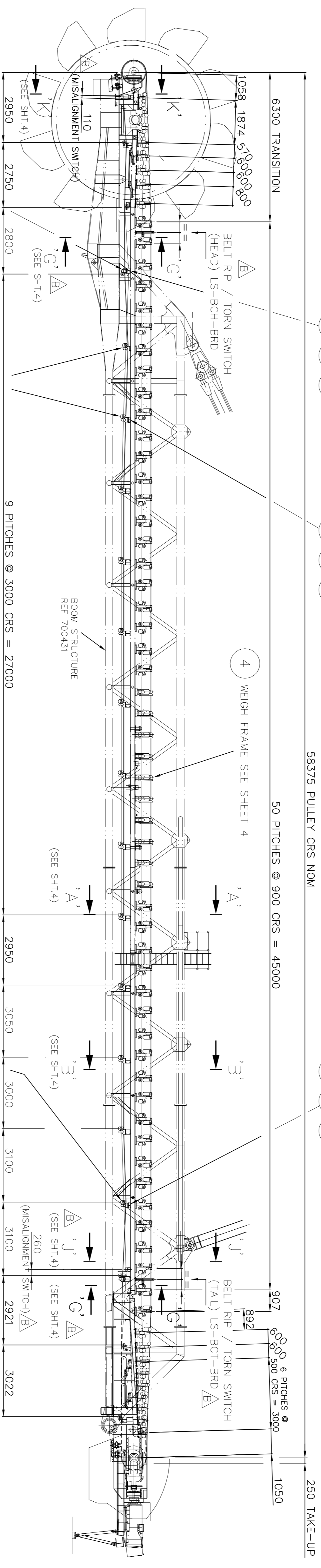
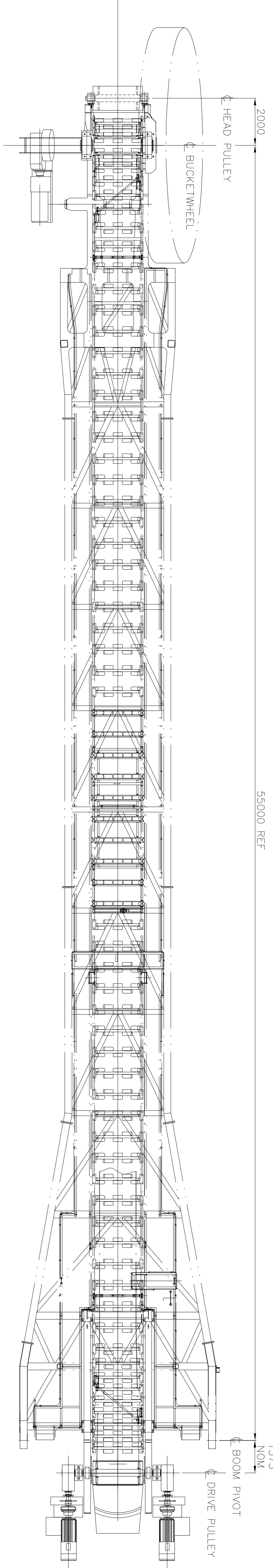

- 10 IDLER 10" INVERTED VEE RETURN
SERIES 30B 2 ROLL Ø152 701932
- 34 20 THK NOM
PACKING SET 2 OFF 701951
- 48 55 61

- 9 IDLER 5" VEE RETURN
SERIES 30B 2 ROLL Ø152 701931
- 34 20 THK NOM
PACKING SET 2 OFF 701951
- 48 55 61

- 15 IDLER SUPPORT TYPE 'B'
2 OFF 701943
- 47 55 61

- 15 IDLER SUPPORT TYPE 'A'
2 OFF 701943
- 47 55 61

- 9 IDLER 5" VEE RETURN
SERIES 30B 2 ROLL Ø152 701931
- 34 20 THK NOM
PACKING SET 2 OFF 701951
- 48 55 61

SEE SHEET 2 FOR DETAILS OF BUCKETWHEEL
END BOOM CONVEYOR MECHANICALS.

SEE SHEET 3 FOR DETAILS OF TAKE-UP
END BOOM CONVEYOR MECHANICALS.

CONVEYOR HANDLING DATA	
BELT SPEED:	4m/SEC
MATERIAL:	IRON ORE @ 2.3 TO 2.65 T/CUBICM
	STACKING @ 9000 T/HR (PEAK)
	RECLAIMING @ 10000 T/HR (PEAK)

DRAWN	CHECKED	APPROVED	DRAWN	CHECKED	APPROVED	DRAWN	CHECKED	APPROVED	DRAWN	CHECKED	APPROVED	DRAWN	CHECKED	APPROVED
DATE	DATE	DATE	DATE	DATE	DATE	DATE	DATE	DATE	DATE	DATE	DATE	DATE	DATE	DATE

ISSUES RAISED GEN. UPDATE.
SEE SHEET 3 NEW IDLER
RETURN ROLLER.
SEE SHEET 8 NEW NIP ANGLE
AS BUILT

SPEED MISALIGNMENT & BELT
TORN SWITCHES ADDED.
SEE ELEVATION SHEET 1 &
SHEET 4.

FIRST ISSUE

DRAWN	CHECKED	APPROVED	DRAWN	CHECKED	APPROVED
DATE	DATE	DATE	DATE	DATE	DATE

UNLESS OTHERWISE SPECIFIED IDENTIFY THE ITEM WITH THE
DRAWING NUMBER AND ISSUE LEVEL AT ▲ AND IN THE MANNER
SHOWN FOR PAINTING AND FOR LUBRICATION SPECIFICATIONS SEE
COMPONENTS LIST.

TOLERANCES UNLESS OTHERWISE STATED (PLUS OR MINUS)		
RANGE	MACH	FAB
0-500	0.25	0.25
501-1000	0.5	0.5
1001-2000	1.0	1.0
ABOVE 2000	2.0	2.0

DO NOT SCALE
IF IN DOUBT - ASK

metso minerals

SOUTH AFRICAN PORT OPERATIONS
IRON ORE TERMINAL - SALDANHA
STACKER RECLAIMER CONTRACT HQH375
SANCTION No. SB01 D1

METSO MATERIALS (UK) LTD
BULK MATERIALS HANDLING BRISTOL
PO BOX 821 ASHTON VALE RD
BRISTOL BS99 5ZB ENGLAND

TITLE
SALDANHA BAY STACKER RECLAIMER
ASSEMBLY OF BOOM CONVEYOR
MECHANICALS, DRIVES & TAKE-UP

MASS	ORIGINAL SCALE	SIZE	SHEET	OF	ISSUE
43561kg	1:100	A1	1	6	C

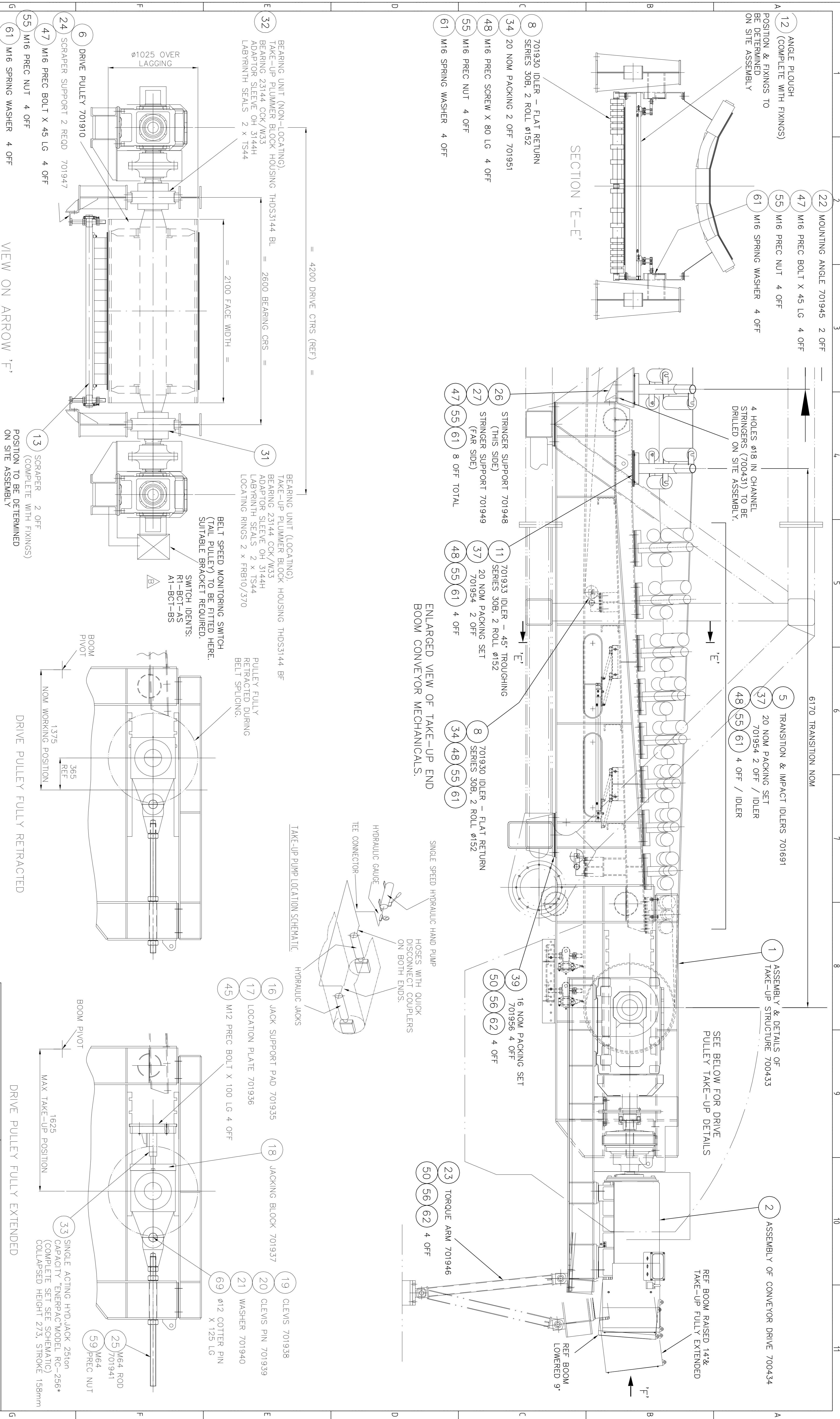

DATE	CHECKED	DATE	APPROVED	DATE	CHECKED	DATE	APPROVED	DATE	CHECKED	DATE	APPROVED	DATE	CHECKED	DATE	APPROVED	DATE	CHECKED	DATE	APPROVED		
11/03/06	DJB	11/03/06	DJB	11/03/06	KD	22/6/06	JWH	22/6/06	JWH	11-3-03	GBL	14 FEB 03	DWB	15 FEB 03	JWH	15/7/03	GBL	5 FEB 03	DWB	5 FEB 03	JWH

ISSUES RAISED GEN. UPDATE. SEE SHEET 3 NEW IDLER RETURN ROLLER. SEE SHEET 6 NEW NIP ANGLE AS BUILT.

REFERENCE TO BELT SPEED SWITCH & LOCATION ADDED.

FIRST ISSUE

UNLESS OTHERWISE SPECIFIED IDENTIFY THE ITEM WITH THE DRAWING NUMBER AND ISSUE LEVEL AT AND IN THE MANNER SHOWN FOR PAINTING AND FOR LUBRICATION SPECIFICATIONS SEE COMPONENTS LIST.

TOLERANCES UNLESS OTHERWISE STATED (PLUS OR MINUS)

RANGE	MACH	FAB	CAST
0-500	0.25	0.25	0.25
501-1000	0.5	0.5	0.5
1001-2000	1.0	1.0	1.0
ABOVE 2000	2.0	2.0	2.0

THIS PRINT AND ALL THE INFORMATION HEREON IS THE PROPERTY OF METSO MINERALS. BULK MATERIALS HANDLING BRISTOL. COPIED OR USED IN ANY WAY DETRIMENTAL TO OUR INTEREST. IT IS LOANED SUBJECT TO RETURN ON DEMAND UNLESS FURNISHED UNDER CONTRACT PROVISIONS.

DO NOT SCALE IF IN DOUBT - ASK

metso minerals

SALDANHA BAY STACKER RECLAIMER ASSEMBLY OF BOOM CONVEYOR MECHANICALS, DRIVES & TAKE-UP

DRIVING NUMBER 700432

MASS kg 1:20 ORIGINAL SCALE A1

SHEET 3 OF 6 ISSUE C

SOUTH AFRICAN PORT OPERATIONS IRON ORE TERMINAL - SALDANHA STACKER RECLAIMER CONTRACT HQH375 SANCTION No. SB01 D1

METSO MINERALS (UK) LTD BULK MATERIALS HANDLING BRISTOL PO BOX 821 ASHTON VALE RD BRISTOL BS99 5ZB ENGLAND

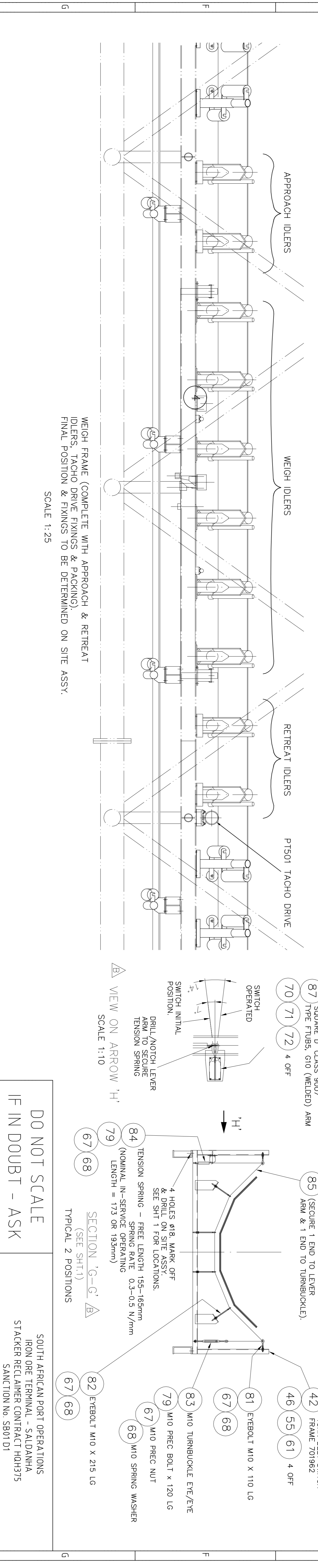
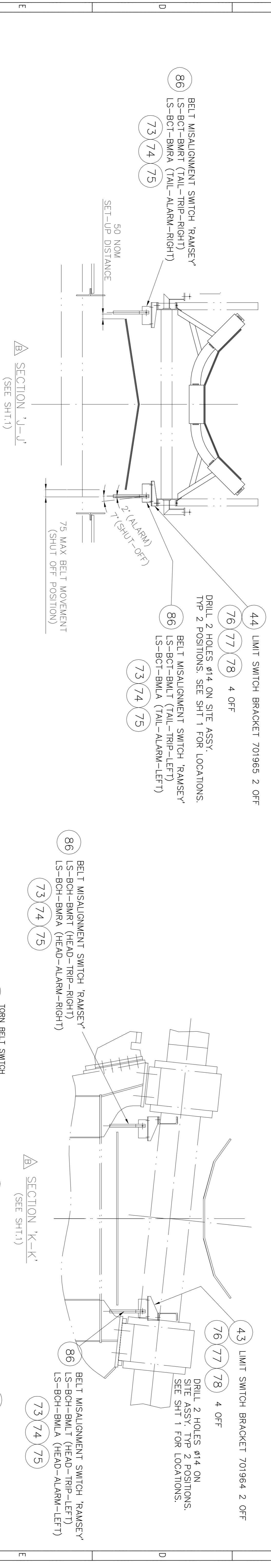
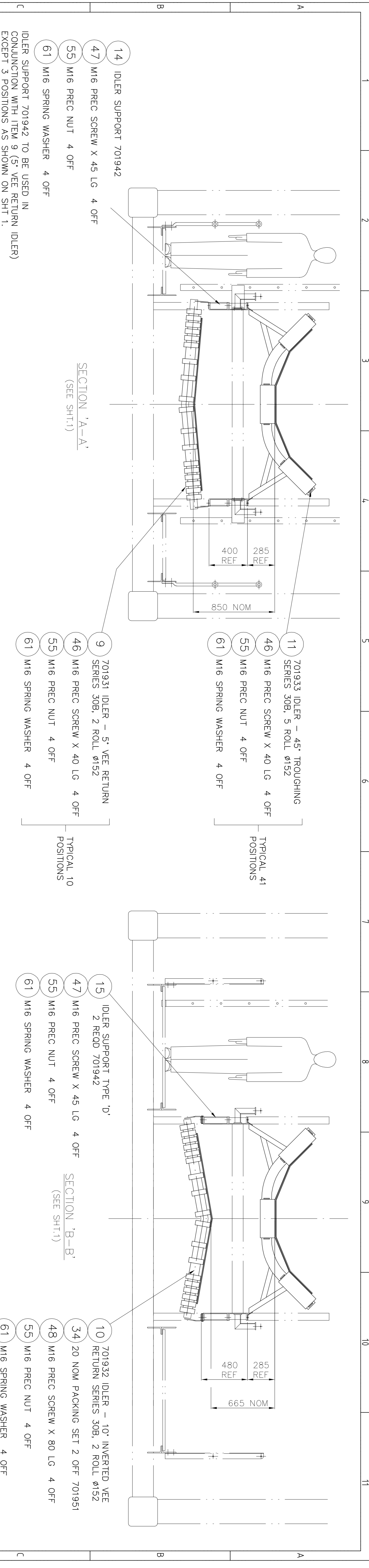

DRAWN	CHECKED	APPROVED	DATE	DRAWN	CHECKED	APPROVED	DATE	DRAWN	CHECKED	APPROVED	DATE	DRAWN	CHECKED	APPROVED	DATE	DRAWN	CHECKED	APPROVED	DATE	DRAWN	CHECKED	APPROVED	DATE	DRAWN	CHECKED	APPROVED	DATE	DRAWN	CHECKED	APPROVED	DATE	DRAWN	CHECKED	APPROVED	DATE																						
1				2				3				4				5				6				7				8				9				10				11																	

ISSUES RAISED GEN. UPDATE:

SEE SHEET 3 NEW IDLER RETURN ROLLER. SEE SHEET 8 NEW NIP ANGLE AS BUILT

SECTIONS G, H, J & K ADDED:

FIRST ISSUE

UNLESS OTHERWISE SPECIFIED IDENTIFY THE ITEM WITH THE DRAWING NUMBER AND ISSUE LEVEL AT ▲ AND IN THE MANNER SHOWN FOR PAINTING AND FOR LUBRICATION SPECIFICATIONS SEE COMPONENTS LIST.

TOLERANCES UNLESS STATED OTHERWISE ARE IN MILLIMETERS UNLESS OTHERWISE STATED (PLUS OR MINUS)

RANGE	MACH	FAB	CAST
0-500	0.25	2	2
501-1000	0.5	3	4
1001-2000	1.0	4	6
ABOVE 2000	2.0	6	10

This print and all the information herein is the property of Metso Minerals. Bulk Materials Handling Bristol and must not be made public, copied or used in any way detrimental to our interests. It is loaned subject to return on demand unless furnished under contract provisions.

DO NOT SCALE IF IN DOUBT - ASK

SOUTH AFRICAN PORT OPERATIONS
IRON ORE TERMINAL - SALDANHA
STACKER RECLAIMER CONTRACT HQH375
SANCTION No. SB01 D1

metso
minerals

METSO MINERALS (UK) LTD
BULK MATERIALS HANDLING BRISTOL
PO BOX 821 ASHTON VALE RD
BRISTOL BS59 5ZB ENGLAND

TITLE SALDANHA BAY STACKER RECLAIMER ASSEMBLY OF BOOM CONVEYOR MECHANICALS, DRIVES & TAKE-UP

MASS Kg 1:20 UOS

SIZE DRAWING NUMBER 700432

SHEET OF 4 6 C

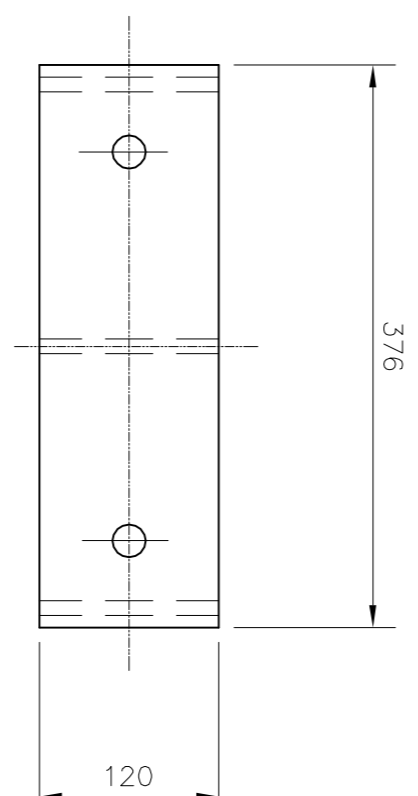
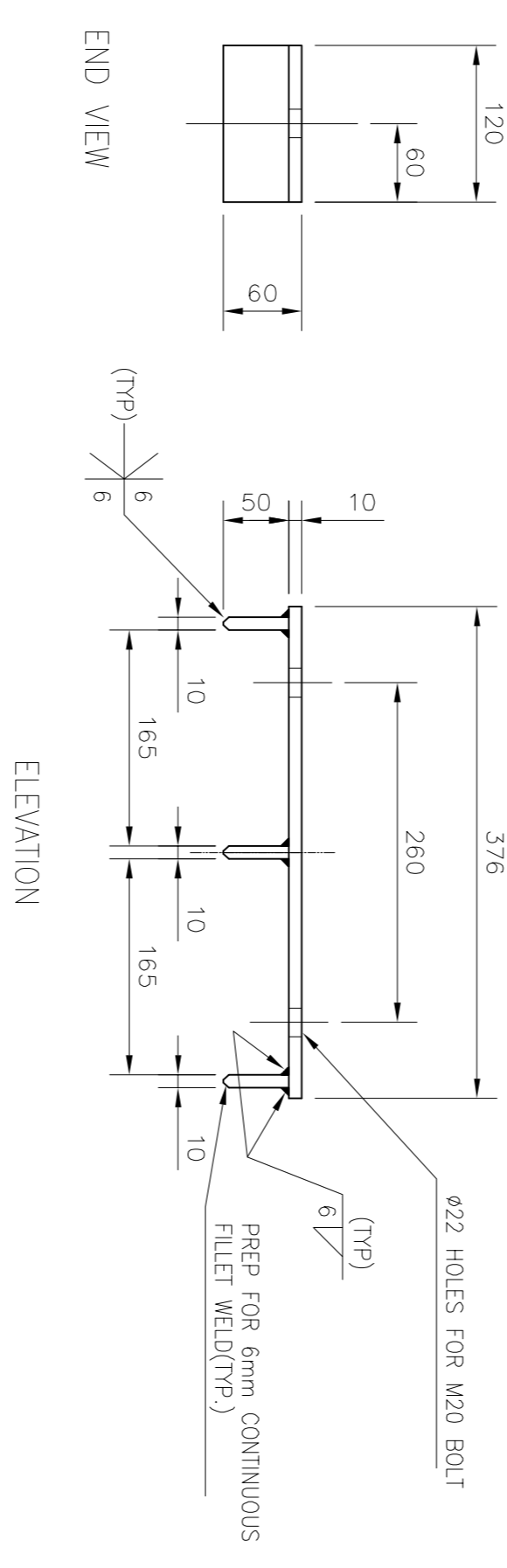
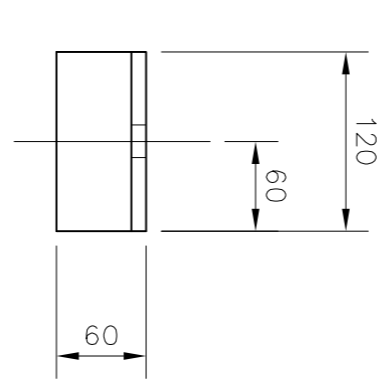
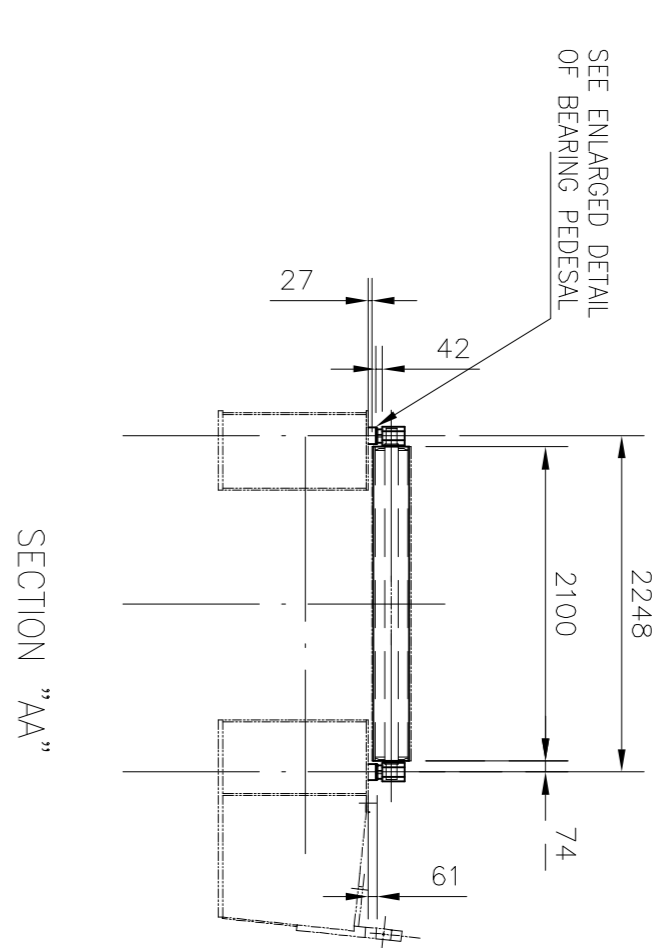
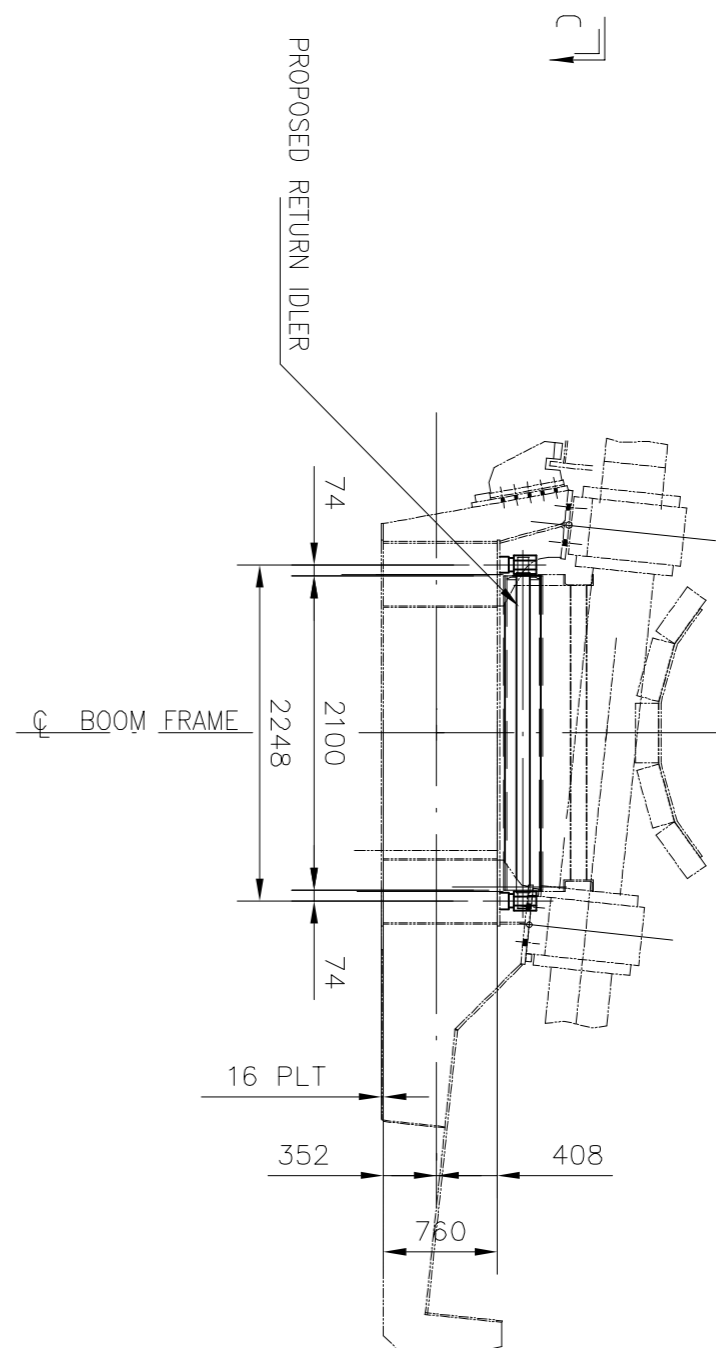
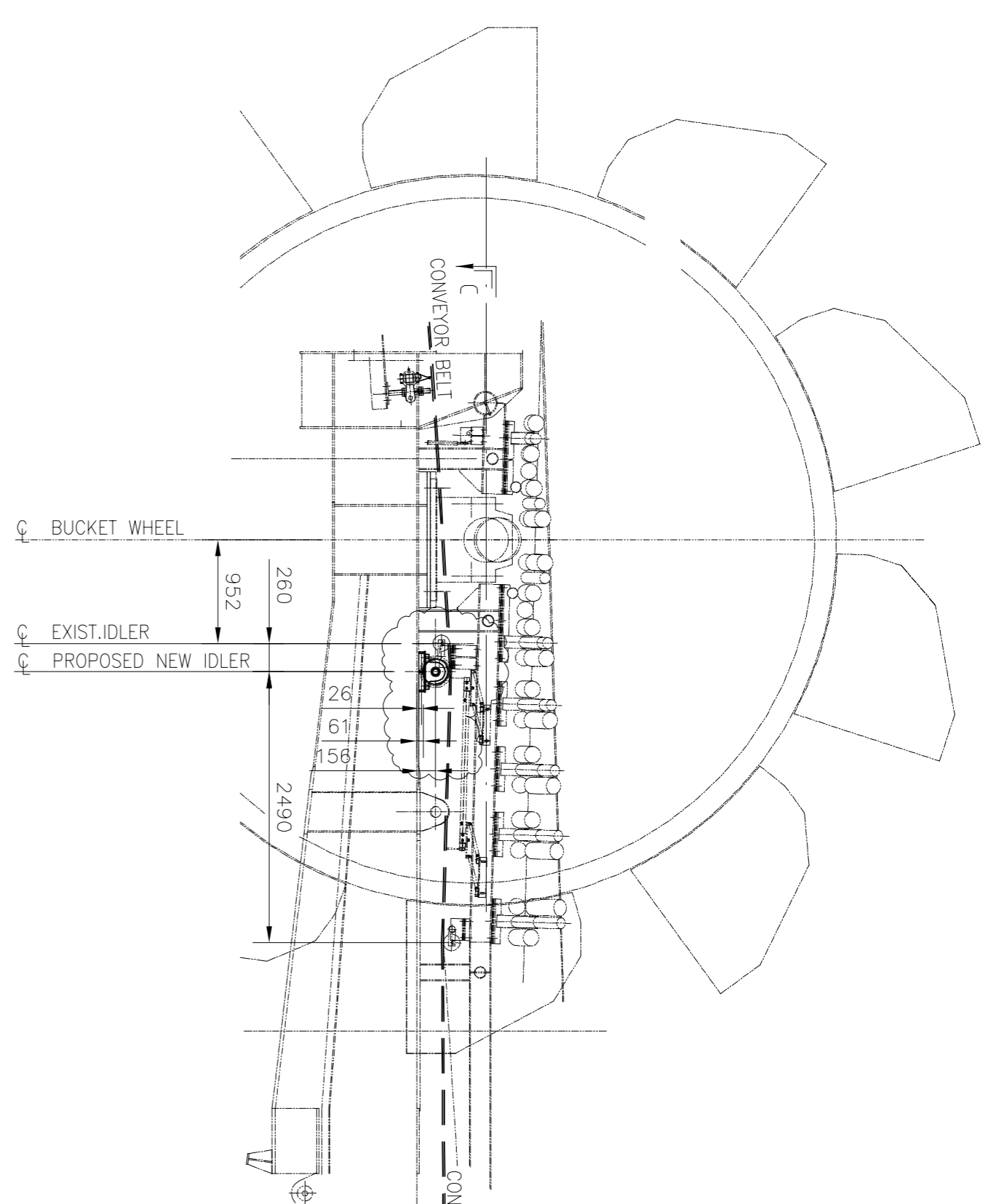

MATERIAL - 10 THK M/S(SABS 1431 G-300 WA)
QTY - 2 OFF

REF DWG:700431 & 700432

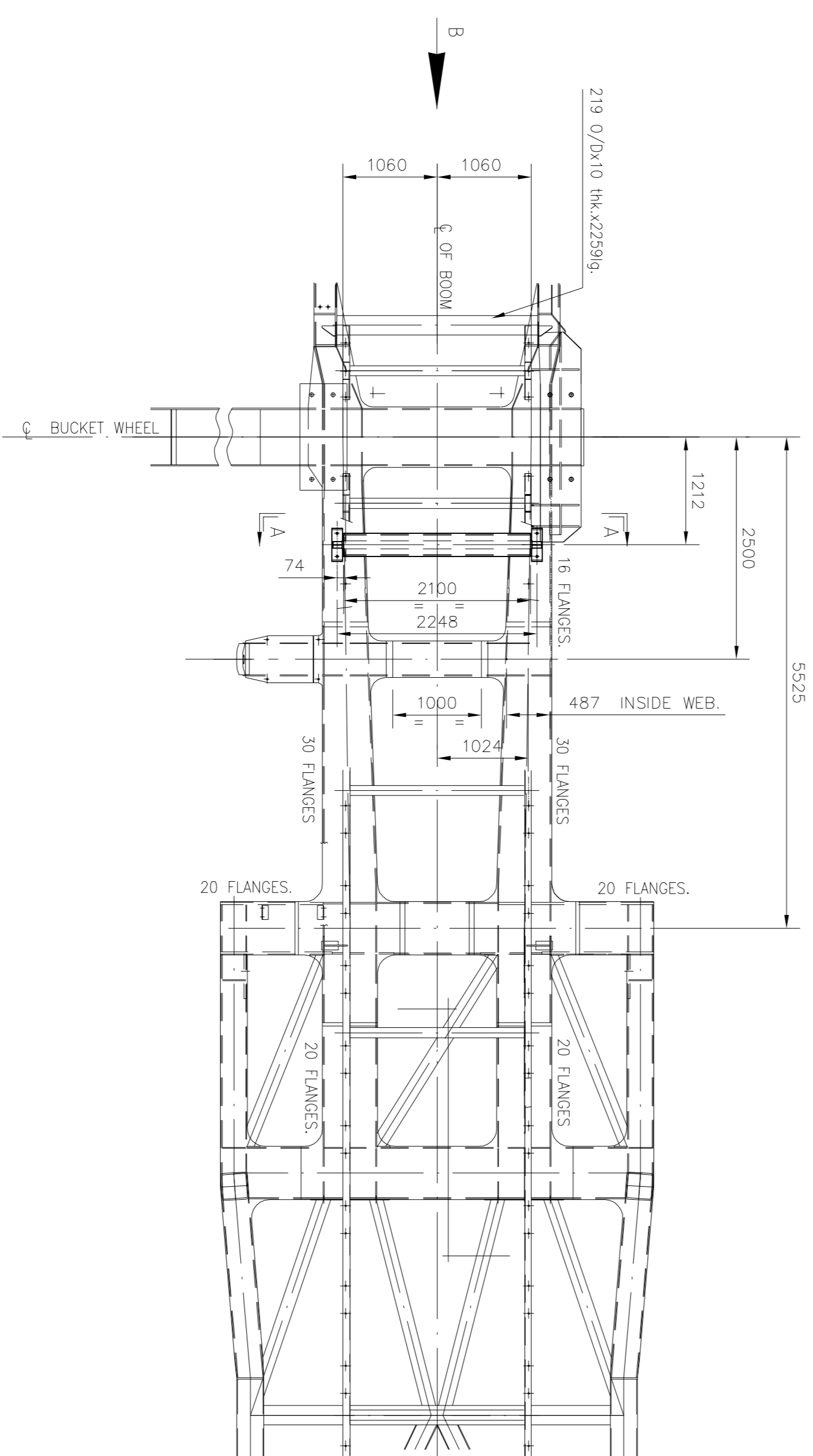

<p>UNLESS OTHERWISE SPECIFIED IDENTIFY THE ITEM WITH THE DRAWING NUMBER AND ISSUE LEVEL AT AND IN THE MANNER SHOWN FOR PAINTING AND FOR LUBRICATION SPECIFICATIONS SEE COMPONENTS LIST.</p> <p>UNLESS OTHERWISE STATED DIMENSIONS ARE IN MILLIMETRES TOLERANCES UNLESS OTHERWISE STATED (PLUS OR MINUS)</p> <table border="1"> <tr> <th>RANGE</th> <th>MACH</th> <th>FAB</th> <th>CAST</th> </tr> <tr> <td>0-500</td> <td>0.5</td> <td>2</td> <td>2</td> </tr> <tr> <td>501-1000</td> <td>0.25</td> <td>3</td> <td>4</td> </tr> <tr> <td>1001-2000</td> <td>1.0</td> <td>4</td> <td>6</td> </tr> <tr> <td>ABOVE 2000</td> <td>2.0</td> <td>6</td> <td>10</td> </tr> </table> <p>This print and all the information herein is the property of Metso Minerals, Bulk Materials Handling Division and must not be made public, copied or used in any way detrimental to our interest. It is loaned subject to return on demand unless furnished under contract provisions.</p>	RANGE	MACH	FAB	CAST	0-500	0.5	2	2	501-1000	0.25	3	4	1001-2000	1.0	4	6	ABOVE 2000	2.0	6	10	<p>ISSUED FOR BRIS TOL APPROVAL. PROPOSED SITE MODIFICATION</p> <p>CHANGE FACE TO FACE OF IDLER ROLL TO 2000 NEW CENTERS OF BEARING 2248 & RE-ISSUE FOR MANUFACTURE</p> <p>ISSUES RAISED GEN UPDATE SEE SH-6 - NIP ANGLES AS BUILT</p>	<p>DO NOT SCALE IF IN DOUBT - ASK</p> <p>THIRD ANGLE DRAWING TO BS 8888 METSO SYMBOLS TO ASSAS 24 SURFACE TEXTURE TO BS 1332 MATERIAL & CONDITION BEFORE MANUFACTURE</p> <p>MATERIAL</p>	<p>SOUTH AFRICAN PORT OPERATIONS IRON ORE TERMINAL - SALDANHA STACKER RECLAIMER CONTRACT HQH375 SANCTION NO. SB01 D1</p> <p>METSO MINERALS (UK) LTD BULK MATERIALS HANDLING BRISTOL PO BOX 821 ASHTON VALE RD BRISTOL BS399 5ZB ENGLAND</p> <p>metso minerals</p>	<p>ISSUES RAISED GEN UPDATE SEE SH-6 - NIP ANGLES AS BUILT</p> <p>CHANGE FACE TO FACE OF IDLER ROLL TO 2000 NEW CENTERS OF BEARING 2248 & RE-ISSUE FOR MANUFACTURE</p> <p>ISSUED FOR BRIS TOL APPROVAL. PROPOSED SITE MODIFICATION</p>	<p>UNLESS OTHERWISE SPECIFIED IDENTIFY THE ITEM WITH THE DRAWING NUMBER AND ISSUE LEVEL AT AND IN THE MANNER SHOWN FOR PAINTING AND FOR LUBRICATION SPECIFICATIONS SEE COMPONENTS LIST.</p> <p>UNLESS OTHERWISE STATED DIMENSIONS ARE IN MILLIMETRES TOLERANCES UNLESS OTHERWISE STATED (PLUS OR MINUS)</p> <table border="1"> <tr> <th>RANGE</th> <th>MACH</th> <th>FAB</th> <th>CAST</th> </tr> <tr> <td>0-500</td> <td>0.5</td> <td>2</td> <td>2</td> </tr> <tr> <td>501-1000</td> <td>0.25</td> <td>3</td> <td>4</td> </tr> <tr> <td>1001-2000</td> <td>1.0</td> <td>4</td> <td>6</td> </tr> <tr> <td>ABOVE 2000</td> <td>2.0</td> <td>6</td> <td>10</td> </tr> </table> <p>This print and all the information herein is the property of Metso Minerals, Bulk Materials Handling Division and must not be made public, copied or used in any way detrimental to our interest. It is loaned subject to return on demand unless furnished under contract provisions.</p>	RANGE	MACH	FAB	CAST	0-500	0.5	2	2	501-1000	0.25	3	4	1001-2000	1.0	4	6	ABOVE 2000	2.0	6	10	<p>ISSUED FOR BRIS TOL APPROVAL. PROPOSED SITE MODIFICATION</p> <p>CHANGE FACE TO FACE OF IDLER ROLL TO 2000 NEW CENTERS OF BEARING 2248 & RE-ISSUE FOR MANUFACTURE</p> <p>ISSUES RAISED GEN UPDATE SEE SH-6 - NIP ANGLES AS BUILT</p>	<p>ISSUED FOR BRIS TOL APPROVAL. PROPOSED SITE MODIFICATION</p> <p>CHANGE FACE TO FACE OF IDLER ROLL TO 2000 NEW CENTERS OF BEARING 2248 & RE-ISSUE FOR MANUFACTURE</p> <p>ISSUES RAISED GEN UPDATE SEE SH-6 - NIP ANGLES AS BUILT</p>	<p>ISSUED FOR BRIS TOL APPROVAL. PROPOSED SITE MODIFICATION</p> <p>CHANGE FACE TO FACE OF IDLER ROLL TO 2000 NEW CENTERS OF BEARING 2248 & RE-ISSUE FOR MANUFACTURE</p> <p>ISSUES RAISED GEN UPDATE SEE SH-6 - NIP ANGLES AS BUILT</p>	<p>ISSUED FOR BRIS TOL APPROVAL. PROPOSED SITE MODIFICATION</p> <p>CHANGE FACE TO FACE OF IDLER ROLL TO 2000 NEW CENTERS OF BEARING 2248 & RE-ISSUE FOR MANUFACTURE</p> <p>ISSUES RAISED GEN UPDATE SEE SH-6 - NIP ANGLES AS BUILT</p>	<p>ISSUED FOR BRIS TOL APPROVAL. PROPOSED SITE MODIFICATION</p> <p>CHANGE FACE TO FACE OF IDLER ROLL TO 2000 NEW CENTERS OF BEARING 2248 & RE-ISSUE FOR MANUFACTURE</p> <p>ISSUES RAISED GEN UPDATE SEE SH-6 - NIP ANGLES AS BUILT</p>
RANGE	MACH	FAB	CAST																																															
0-500	0.5	2	2																																															
501-1000	0.25	3	4																																															
1001-2000	1.0	4	6																																															
ABOVE 2000	2.0	6	10																																															
RANGE	MACH	FAB	CAST																																															
0-500	0.5	2	2																																															
501-1000	0.25	3	4																																															
1001-2000	1.0	4	6																																															
ABOVE 2000	2.0	6	10																																															

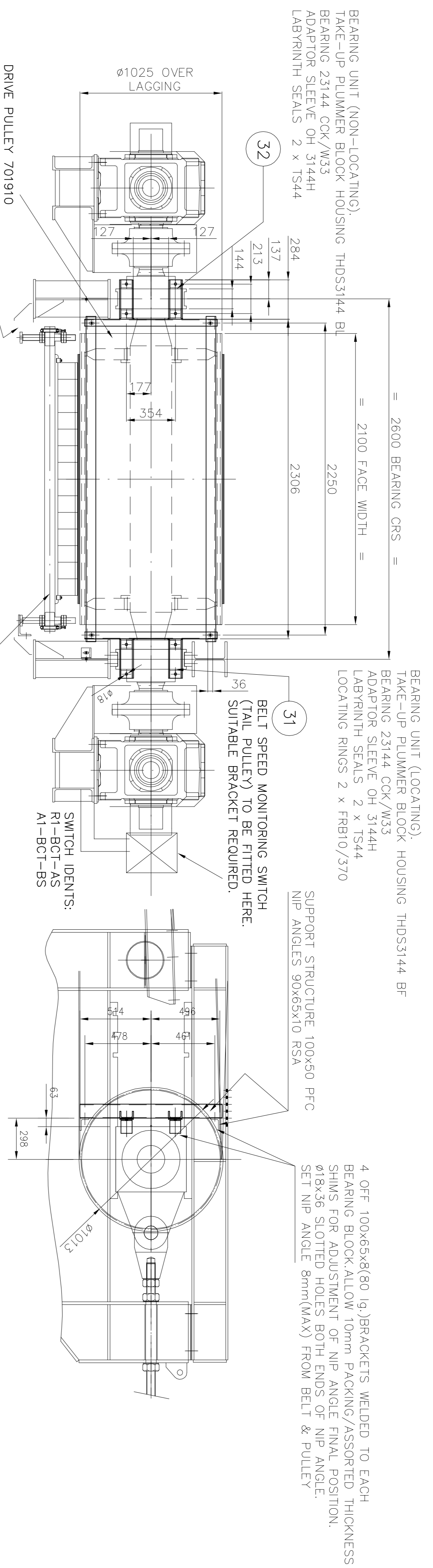

- 24 SCRAPER SUPPORT 2 REOD 701947
- 47 M16 PREC BOLT X 45 LG 4 OFF
- 55 M16 PREC NUT 4 OFF
- 61 M16 SPRING WASHER 4 OFF

ELEVATION
VIEW ON ARROW 'F'

END VIEW

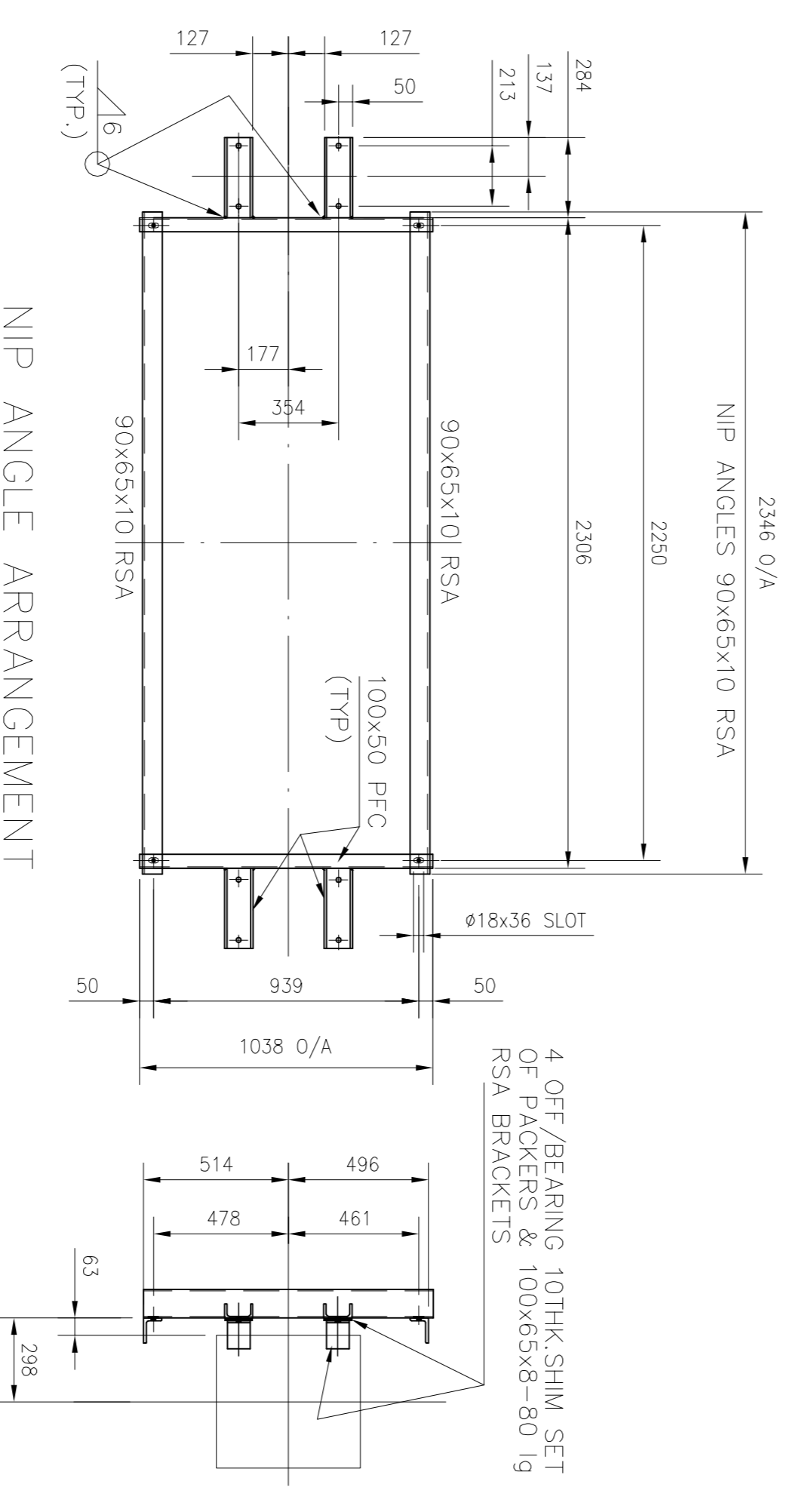

NIP ANGLE ARRANGEMENT

ISSUES RAISED GEN. UPDATE AS BUILT

ISSUED FOR PRICING & FABRICATION

ISSUE FOR BRISTOL APPROVAL FIRST ISSUE

DATE	CHECKED	APPROVED	DATE	CHECKED	APPROVED	DATE	CHECKED	APPROVED	DATE	CHECKED	APPROVED	DATE	CHECKED	APPROVED	DATE	CHECKED	APPROVED
17/03/06	DDB	RD	22/6/06	JWH	DDB	RD	22/6/06	JWH	10/01/06	DDB	RD	22/6/06	JWH				

DO NOT SCALE
IF IN DOUBT - ASK

metso minerals

SOUTH AFRICAN PORT OPERATIONS
IRON ORE TERMINAL - SALDANHA
STACKER RECLAIMER CONTRACT HQH375
SANCTION No. SB01 D1

METSO MINERALS (UK) LTD
BULK MATERIALS HANDLING BRISTOL
PO BOX 821 ASHTON VALE RD
BRISTOL BS399 5ZB ENGLAND

SALDANHA BAY STACKER RECLAIMER ASSEMBLY OF BOOM CONVEYOR MECHANICALS, DRIVES & TAKE-UP

MASS kg ORIGINAL SCALE 1:20 SIZE A1 DRAWING NUMBER 700432 SHEET 6 OF 6 ISSUE C

UNLESS OTHERWISE SPECIFIED IDENTIFY THE ITEM WITH THE DRAWING NUMBER AND ISSUE LEVEL AT THE END IN THE MANNER SHOWN FOR PAINTING AND FOR LUBRICATION SPECIFICATIONS SEE COMPONENTS LIST.

UNLESS OTHERWISE STATED DIMENSIONS ARE IN MILLIMETRES TOLERANCES UNLESS OTHERWISE STATED (PLUS OR MINUS)

RANGE	MACH	FAB	CAST
0-500	0.25	3	2
501-1000	0.5	3	4
1001-2000	1.0	4	6
ABOVE 2000	2.0	6	10

This print and all the information herein is the property of Metso Minerals. Bulk Materials Handling Bristol and must not be made public, copied or used in any way detrimental to our interest. It is loaned subject to return on demand unless furnished under contract provisions.

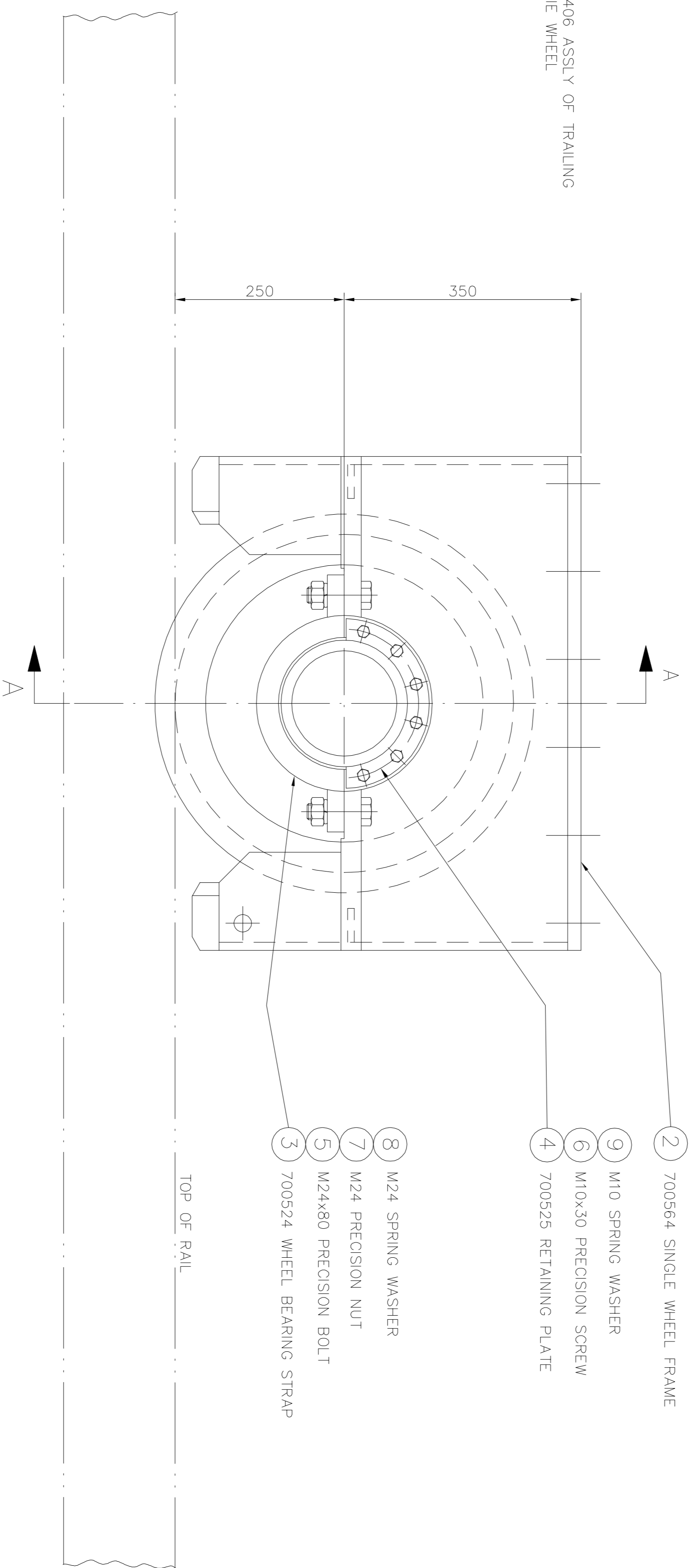
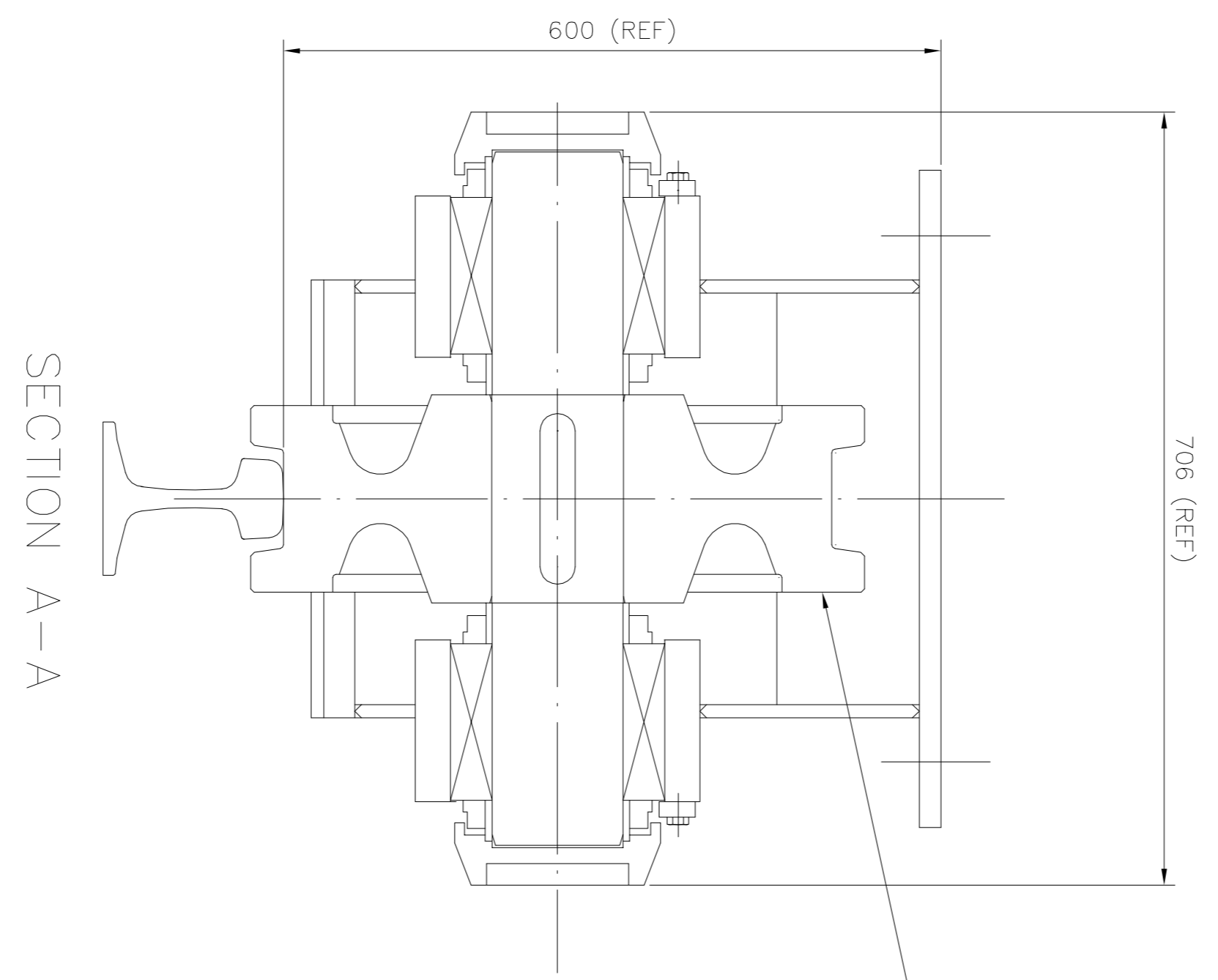
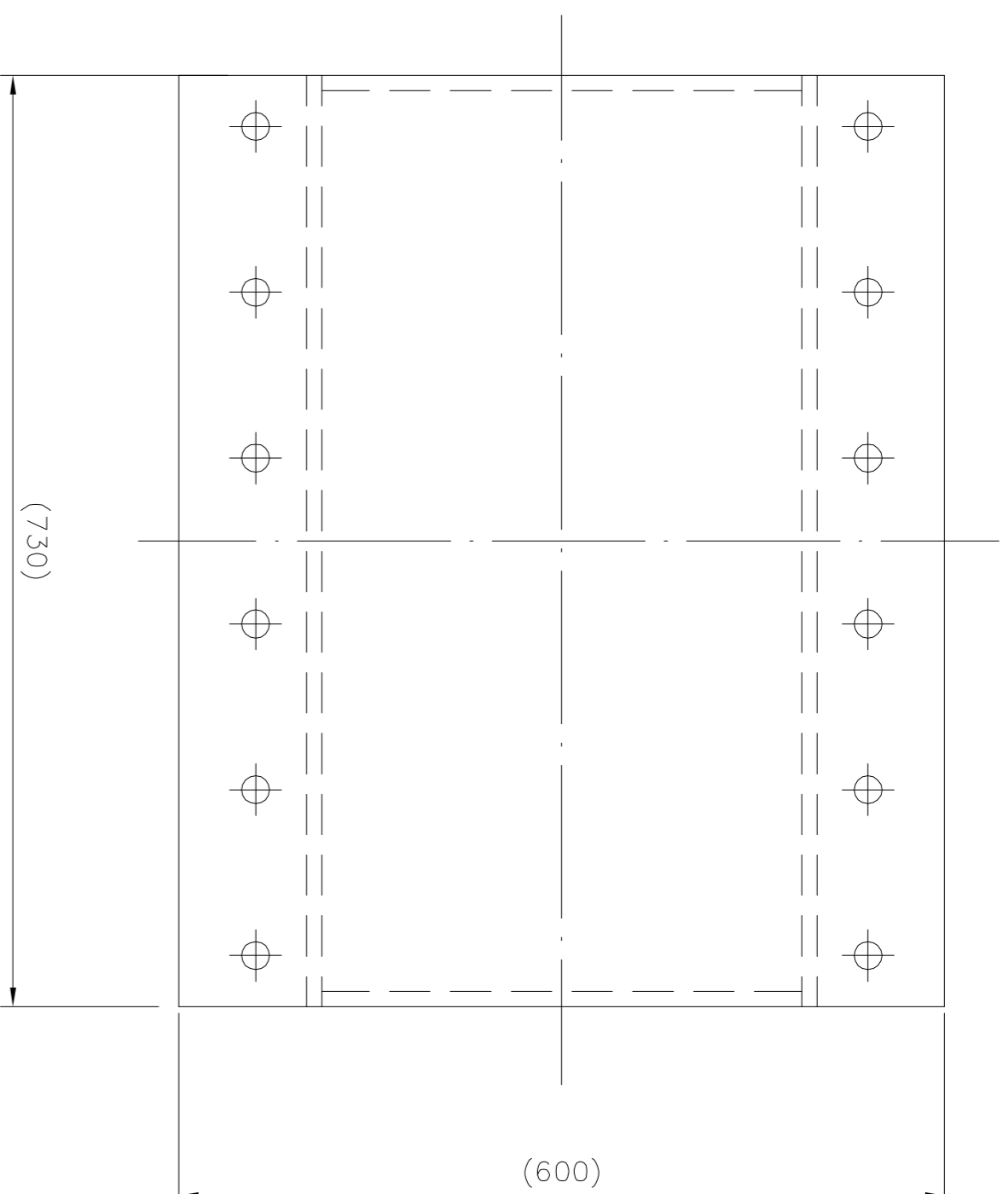

DATE	CHECKED	DATE	APPROVED	DATE	DATE	DATE	DATE	DATE	DATE	DATE	DATE	DATE	DATE	DATE	DATE	DATE	DATE	DATE	DATE	DATE	

<p>ISSUES RAISED GEN UPDATE AS BUILT</p> <p>22.03.06</p>	<p>FIRST ISSUE</p> <p>31/05/2002</p>	<p>UNLESS OTHERWISE SPECIFIED IDENTIFY THE ITEM WITH THE DRAWING NUMBER AND ISSUE LEVEL AT AND IN THE MANNER SHOWN FOR PAINTING AND FOR LUBRICATION SPECIFICATIONS SEE COMPONENTS LIST.</p> <p>TOLERANCES UNLESS OTHERWISE STATED (PLUS OR MINUS) ARE IN MILLIMETRES</p> <table border="1"> <tr> <td>RANGE</td> <td>MACH</td> <td>FAB</td> <td>CAST</td> </tr> <tr> <td>0-500</td> <td>0.25</td> <td>2</td> <td>2</td> </tr> <tr> <td>501-1000</td> <td>0.5</td> <td>3</td> <td>4</td> </tr> <tr> <td>1001-2000</td> <td>1.0</td> <td>4</td> <td>6</td> </tr> <tr> <td>ABOVE 2000</td> <td>2.0</td> <td>6</td> <td>10</td> </tr> </table> <p>This print and all the information herein is the property of Metso Minerals. Bulk Materials Handling Bristol and must not be made public, copied or used in any way detrimental to our interest. It is loaned subject to return on demand unless furnished under contract provisions.</p>	RANGE	MACH	FAB	CAST	0-500	0.25	2	2	501-1000	0.5	3	4	1001-2000	1.0	4	6	ABOVE 2000	2.0	6	10	<p>DO NOT SCALE IF IN DOUBT - ASK</p> <p>602 kg</p>	<p>ORIGINAL SCALE 1:5</p>	<p>SIZE A1</p>	<p>DRAWING NUMBER 700449</p>	<p>SHEET OF 1 1</p>	<p>ISSUE B</p>
RANGE	MACH	FAB	CAST																									
0-500	0.25	2	2																									
501-1000	0.5	3	4																									
1001-2000	1.0	4	6																									
ABOVE 2000	2.0	6	10																									

metso minerals

SOUTH AFRICAN PORT OPERATIONS
IRON ORE TERMINAL - SALDANHA
STACKER RECLAIMER CONTRACT HQH375
SANCTION No. SB01 D1

METSO MINERALS (UK) LTD
BULK MATERIALS HANDLING BRISTOL
PO BOX 821 ASHTON VALE RD
BRISTOL BS99 5ZB ENGLAND

TITLE
ASSEMBLY OF SINGLE WHEEL BOGIE

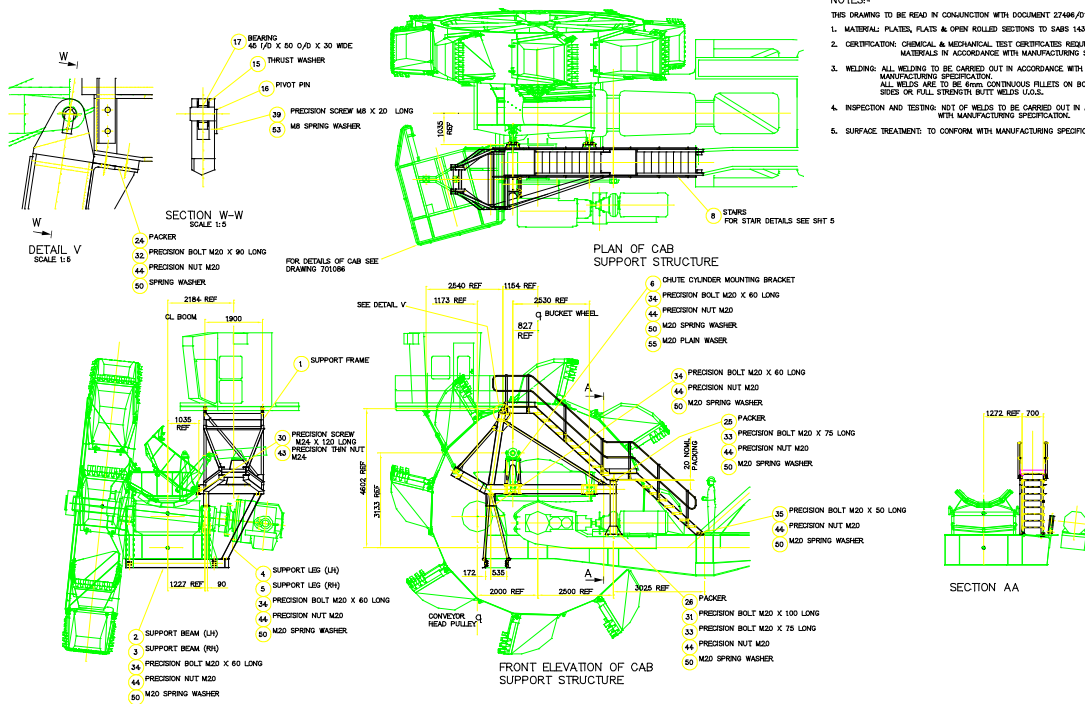

NOTES-

- THIS DRAWING TO BE READ IN CONJUNCTION WITH DOCUMENT 27496/015, MANUFACTURING SPECIFICATION.
1. MATERIAL: PLATES, FLATS & OPEN ROLLED SECTIONS TO SABS 1451 GRADE 300WA UGS.
 2. CERTIFICATION: CHEMICAL & MECHANICAL TEST CERTIFICATES REQUIRED FOR ALL MATERIALS IN ACCORDANCE WITH MANUFACTURING SPECIFICATION.
 3. WELDING: ALL WELDING TO BE CARRIED OUT IN ACCORDANCE WITH THE MANUFACTURING SPECIFICATION. ALL WELDS ARE TO BE 6mm CONTINUOUS FILLETS ON BOTH SIDES OR FULL STRENGTH BUTT WELDS UGS.
 4. INSPECTION AND TESTING: NDT OF WELDS TO BE CARRIED OUT IN ACCORDANCE WITH MANUFACTURING SPECIFICATION.
 5. SURFACE TREATMENT: TO CONFORM WITH MANUFACTURING SPECIFICATION.



DWR, REVISED SEE SHEET 5

FIRST ISSUE

AS BUILT

TRV VAC
04.08.04

DJS FMB JRM
05/08/02 16/11/02 28/11/02

ASSEMBLY & DETAILS OF
CAB SUPPORT & ACCESS

2921kg 1:50

700451

1 5 B

- GENERAL NOTES
- STANCHION AND HANDRAILING DETAILS ON SHEET 2
 - FRAMEWORK AND FLOORING DETAILS ON SHEET 2
 - SECTION A-A ON SHEET 2
 - WINDOWS "W1"-"W6" DETAILS ON SHEET 2

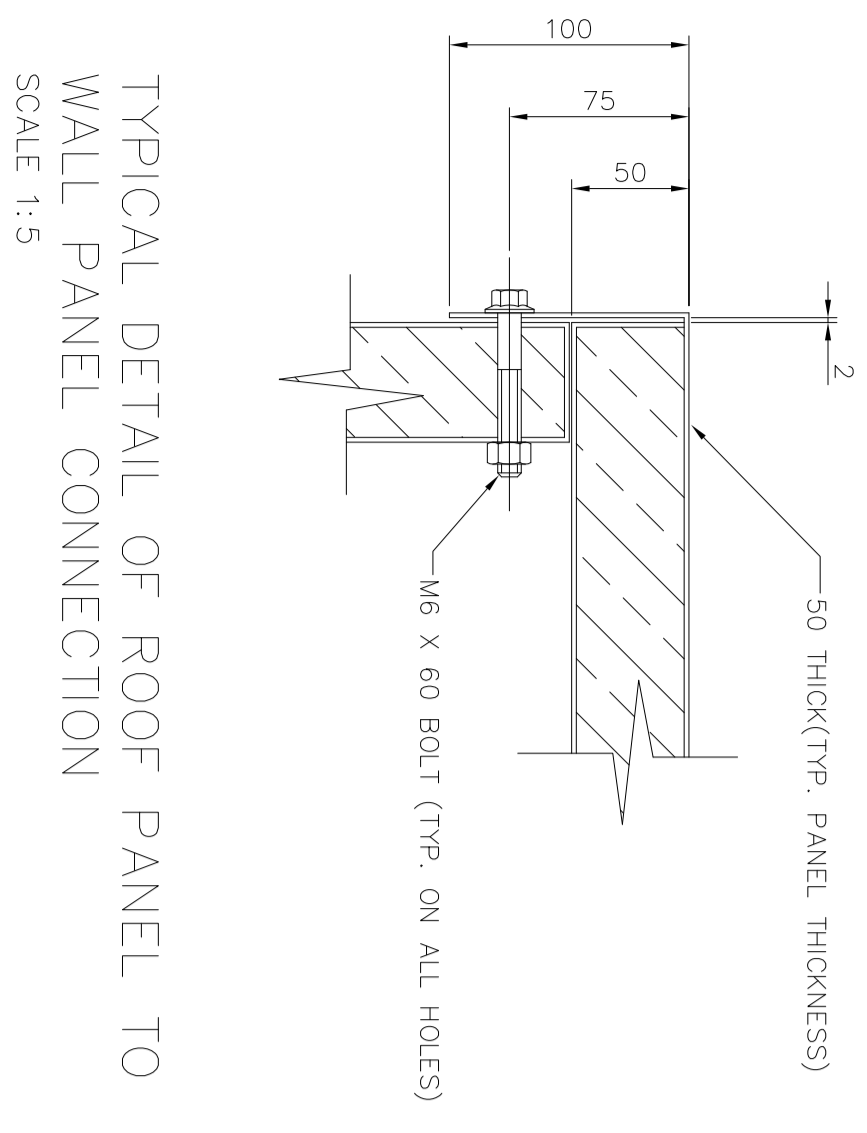

TYPICAL DETAIL OF ROOF PANEL TO WALL PANEL CONNECTION
SCALE 1:5

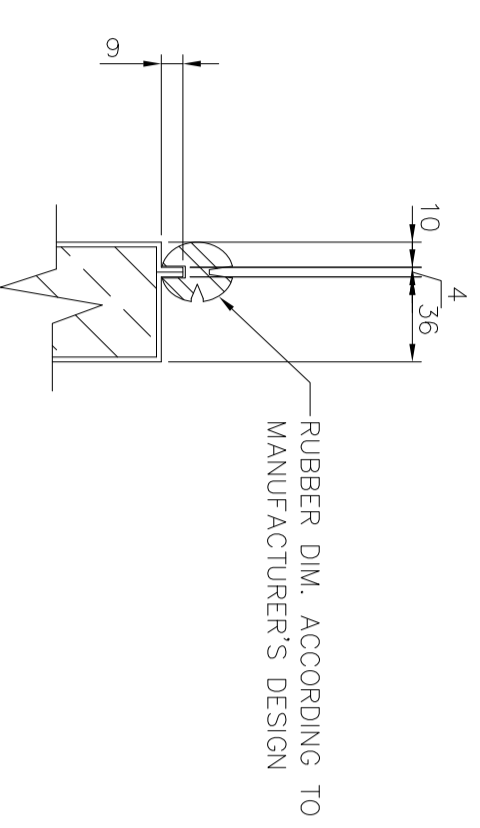

TYPICAL DETAIL OF WINDOW RUBBERING TO PANEL CONNECTION
SCALE 1:5

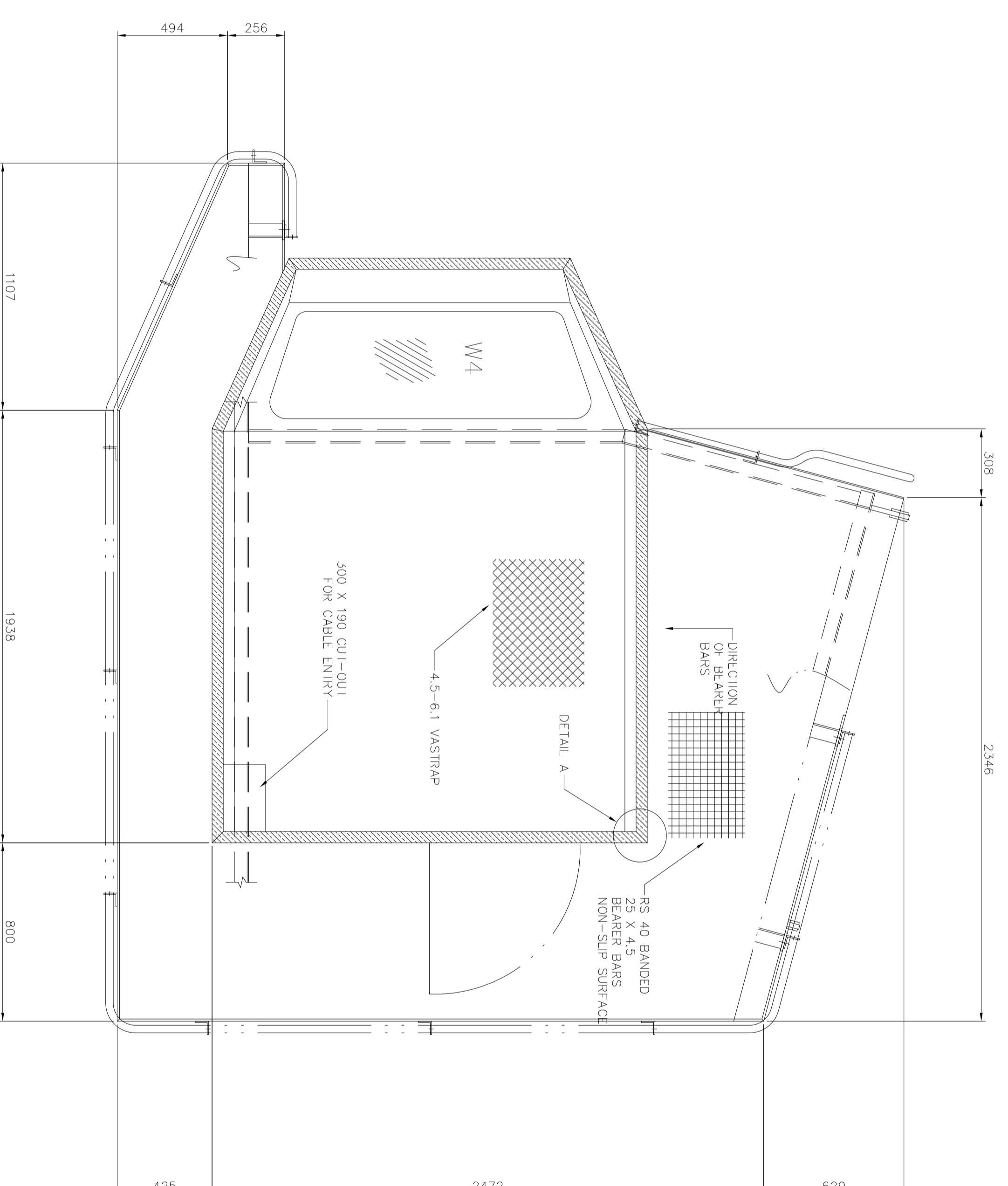

SECTION D-D

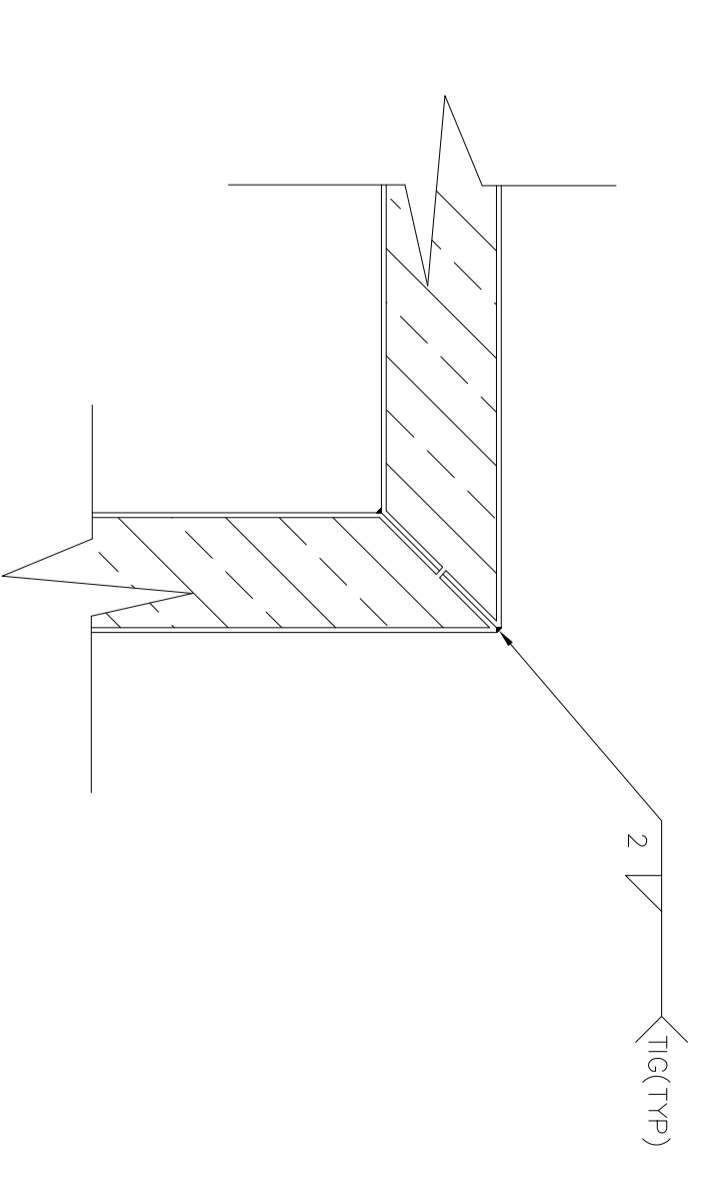

DETAIL A : TYPICAL JOINT DETAIL OF ALL JOINTS
SCALE 1:5

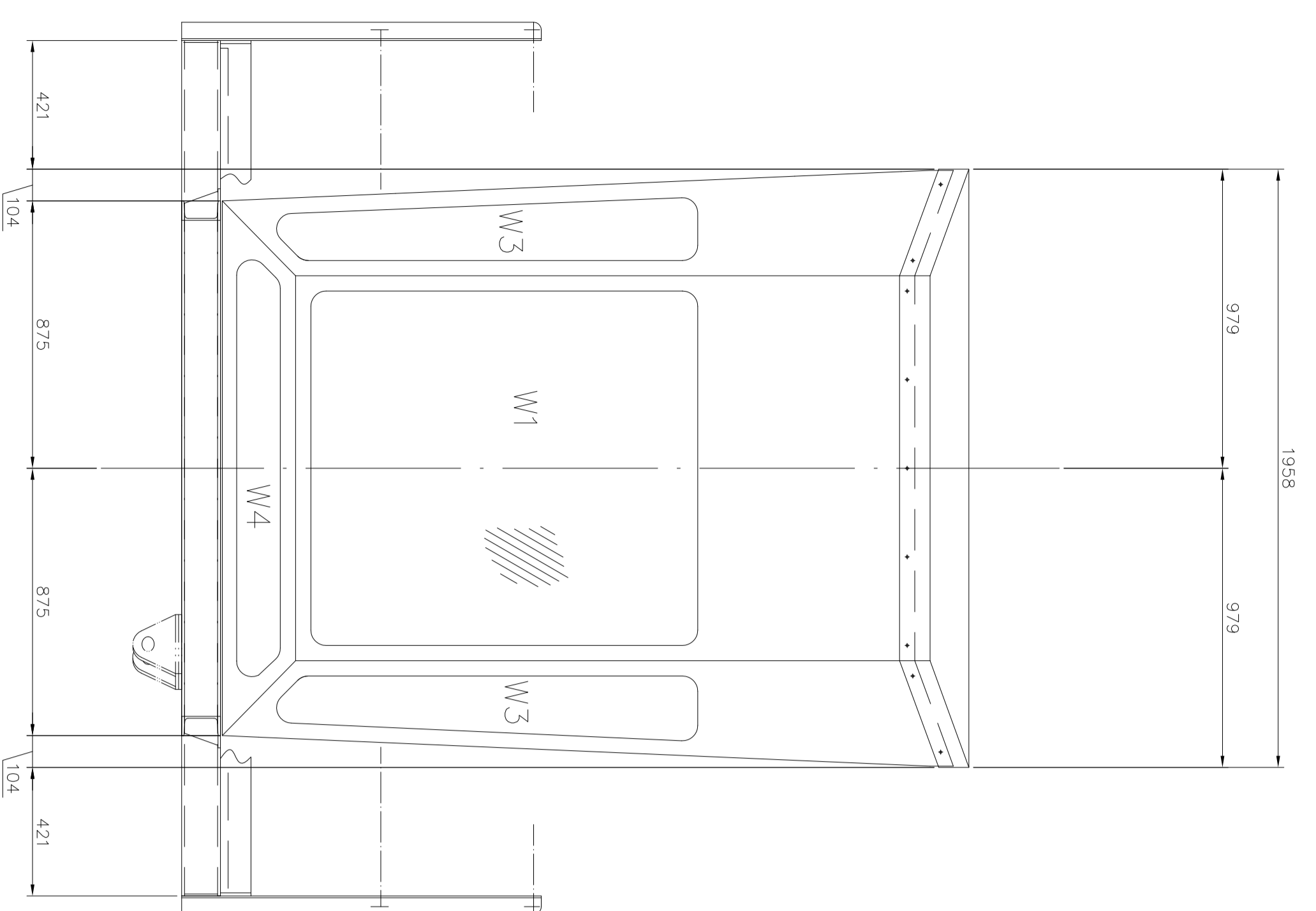

FRONT ELEVATION

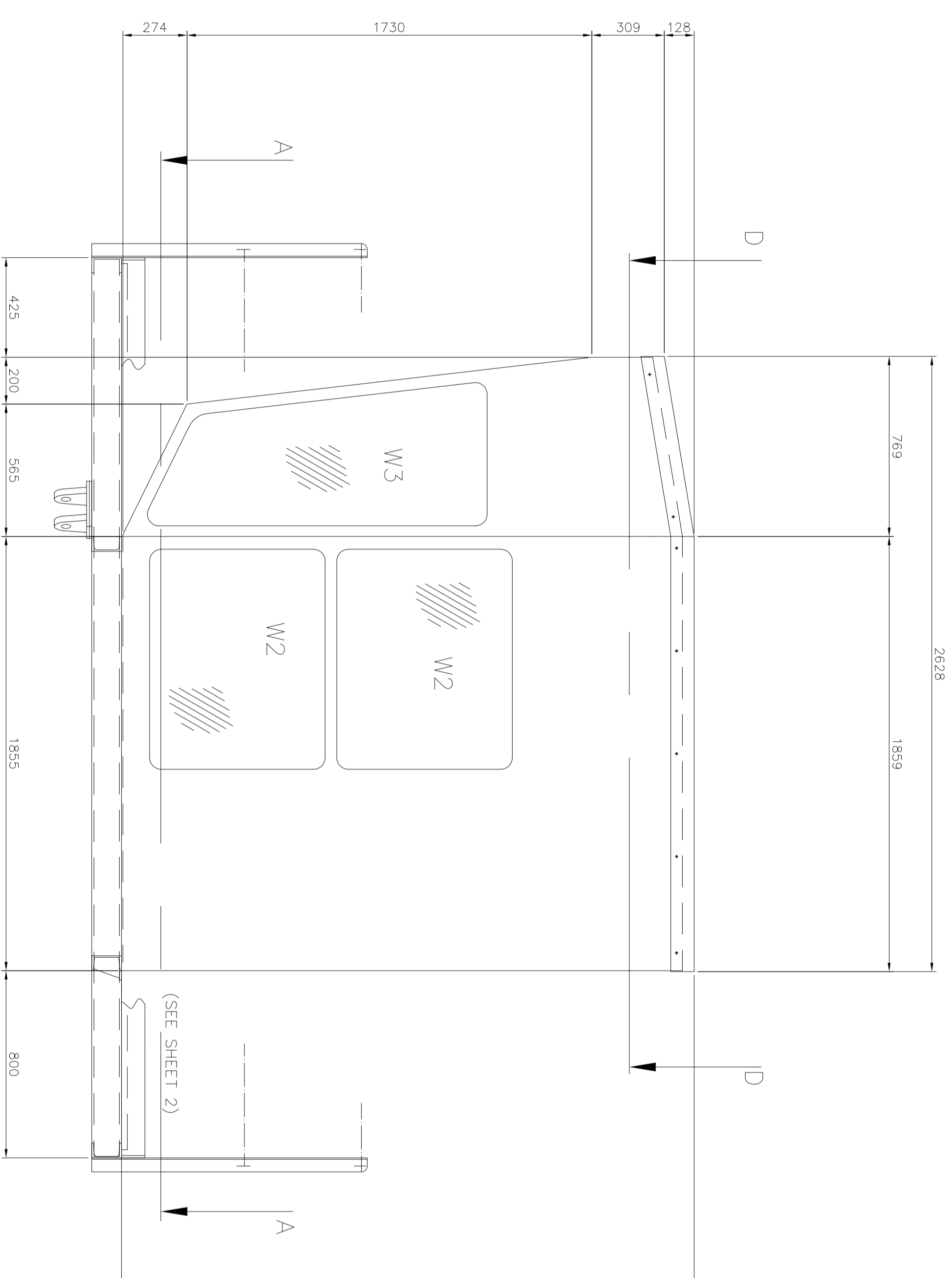

SIDE ELEVATION

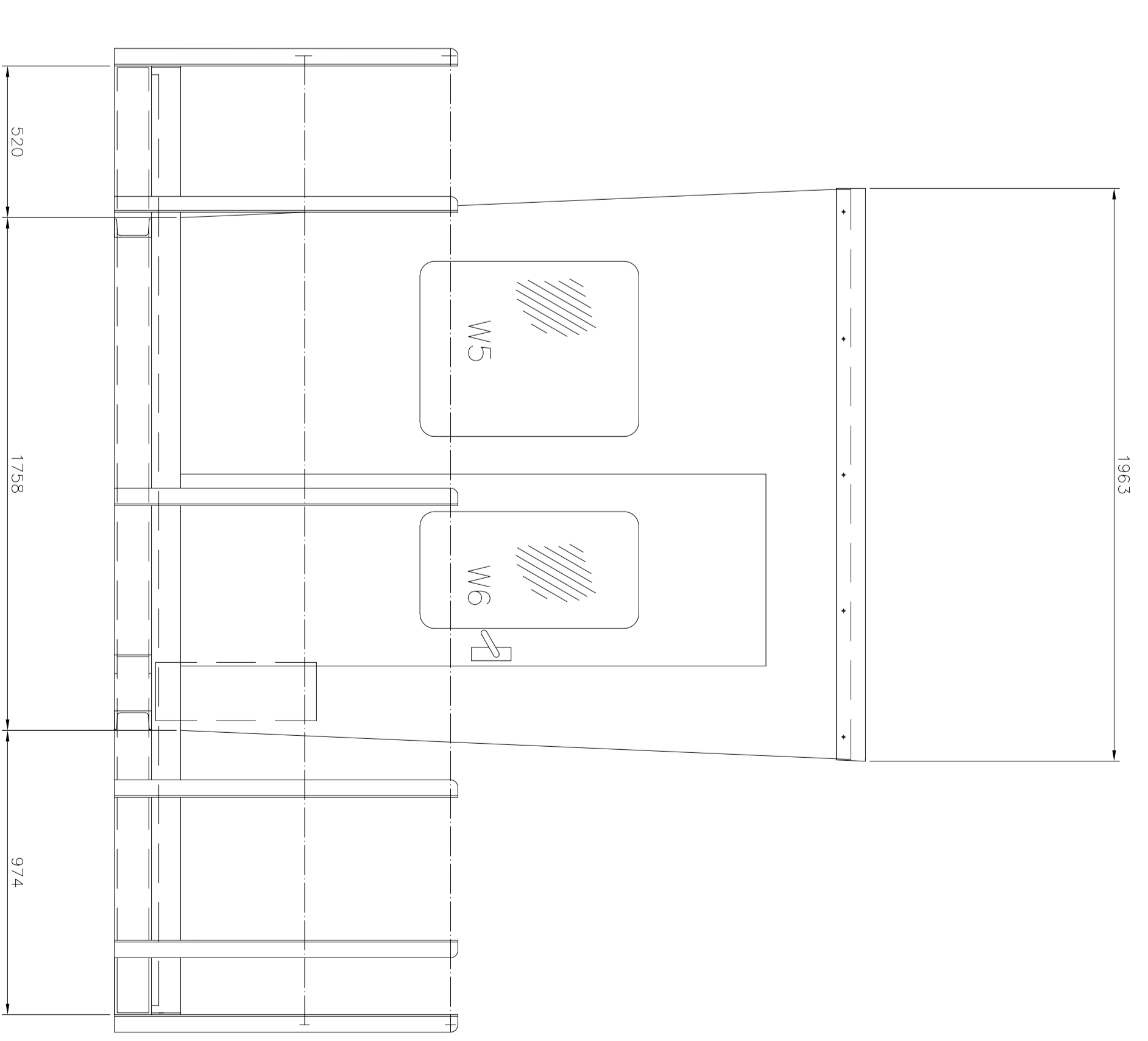

REAR ELEVATION

ISSUED FOR APPROVAL
AS BUILT

AMS
11/03/2003

SALDANHA STACKER RECLAIMER
ASSEMBLY AND DETAILS OF
OPERATORS CAB

Kg

1:15

700452

1 4 A

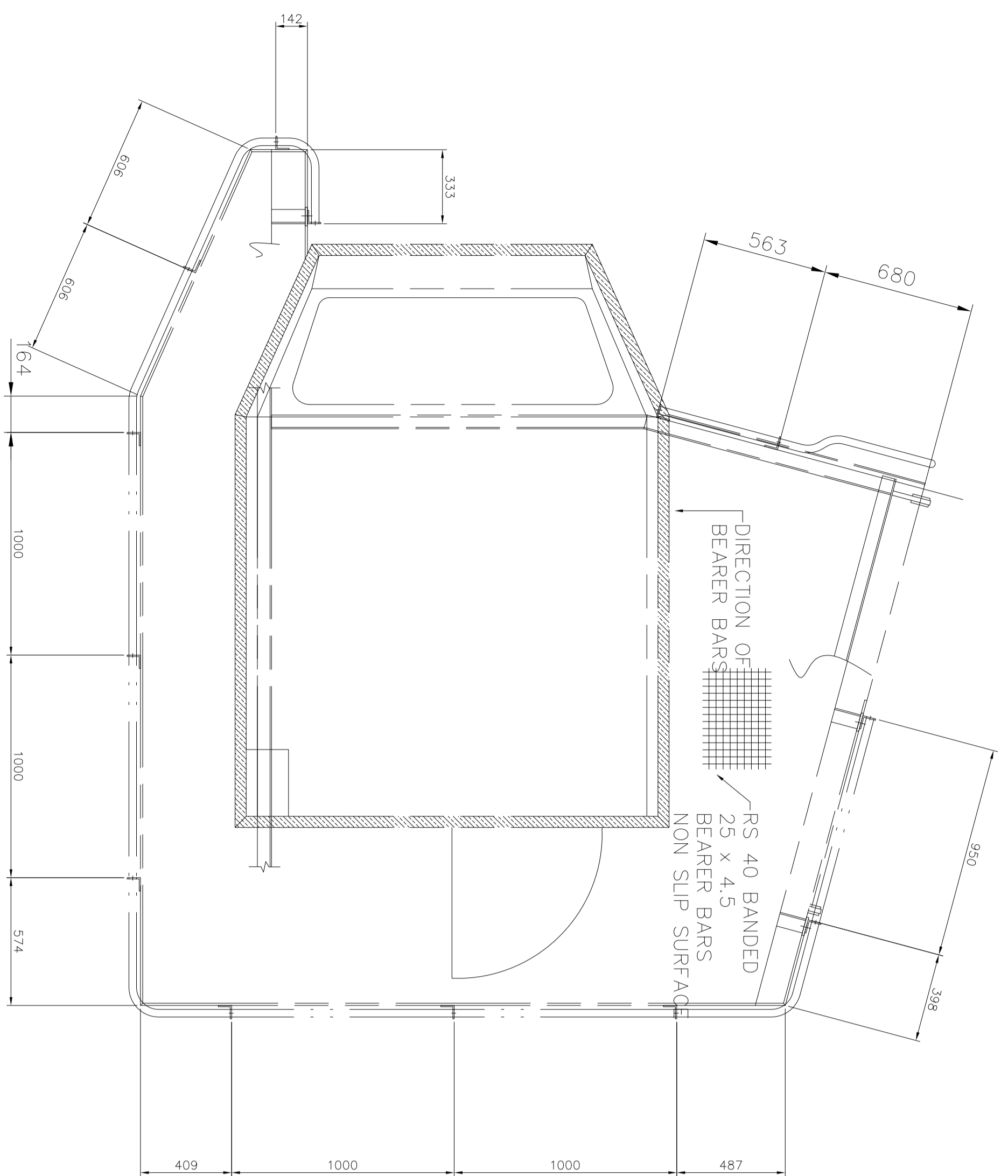

SECTION D-D
DETAIL OF HANDRAILING

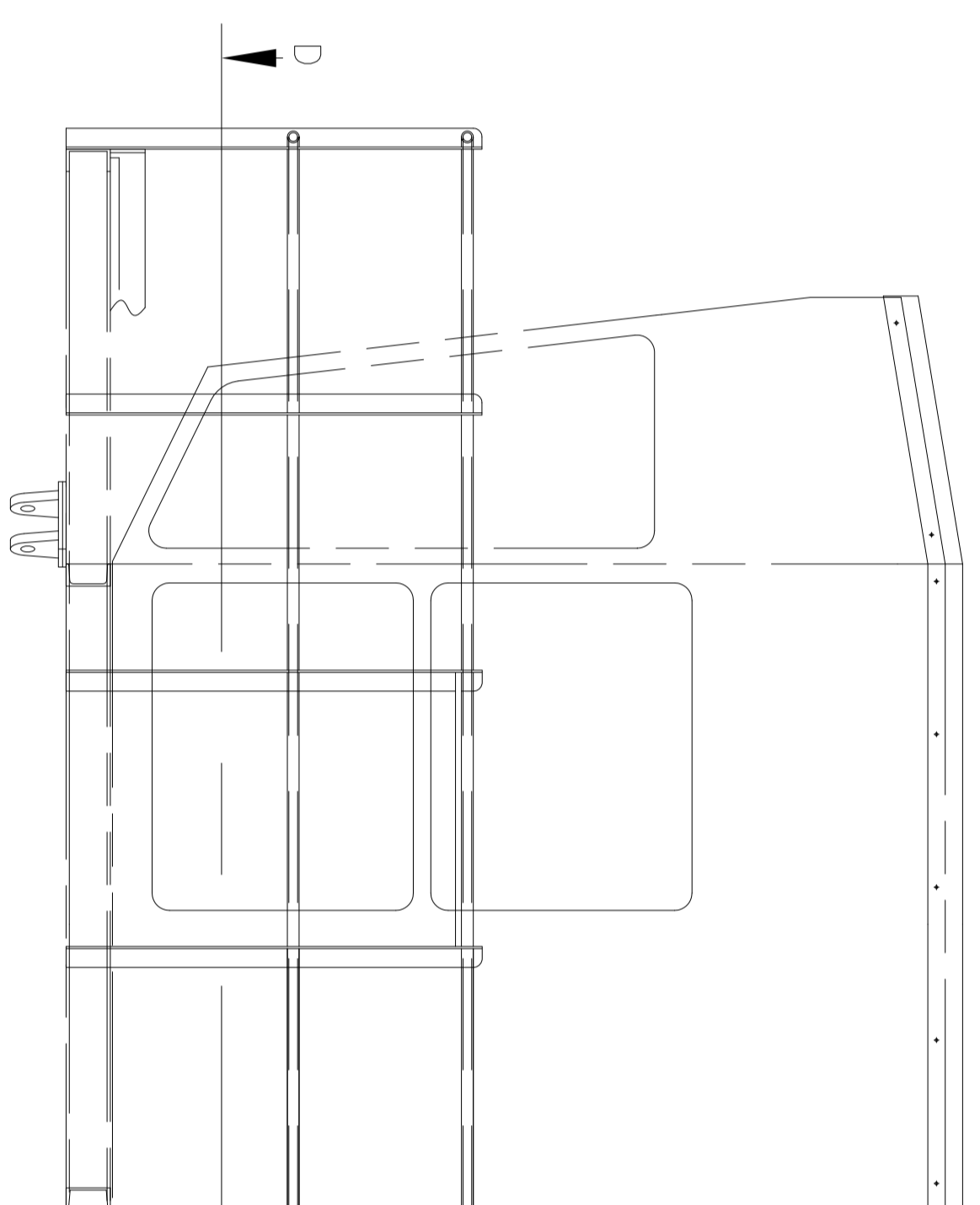

SIDE ELEVATION
DETAIL OF HANDRAILING

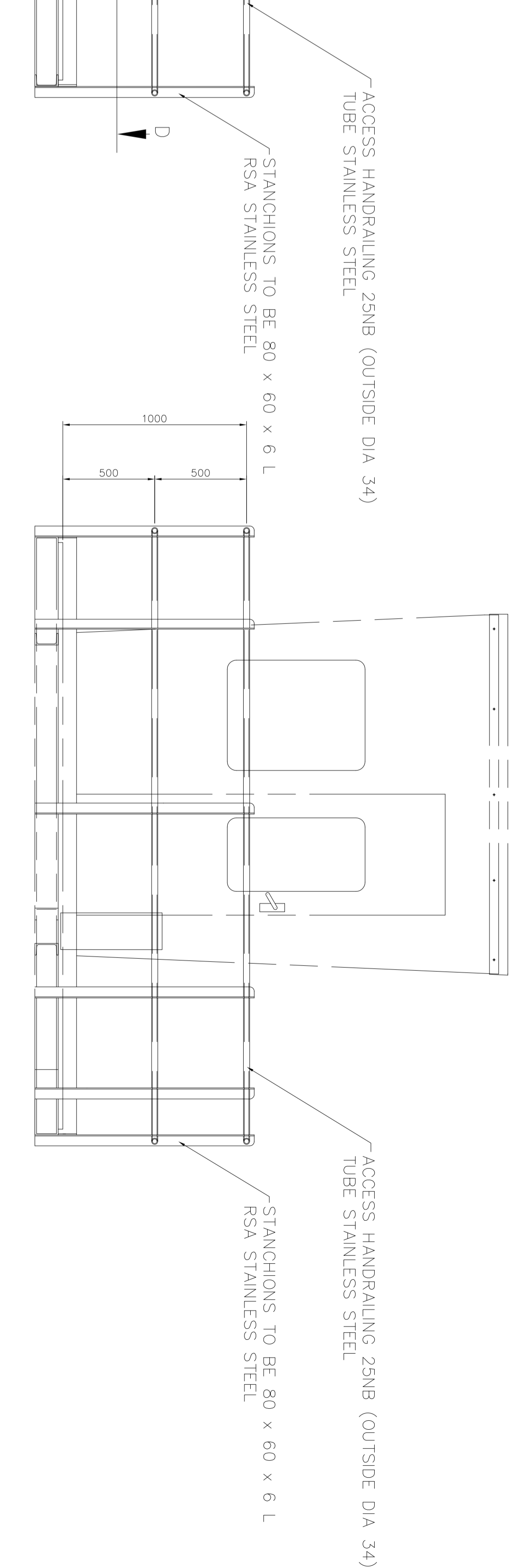

REAR ELEVATION
DETAIL OF HANDRAILING

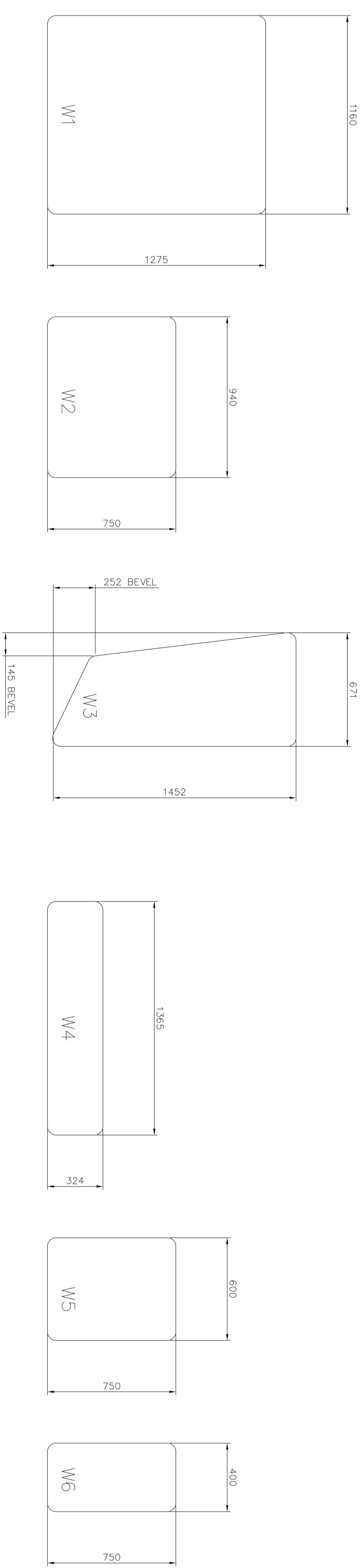

DETAIL OF WINDOWS "W1" - "W6"
(SEE SHEET 1 FOR DETAIL OF PANEL
CUT-OUT FOR WINDOWS)

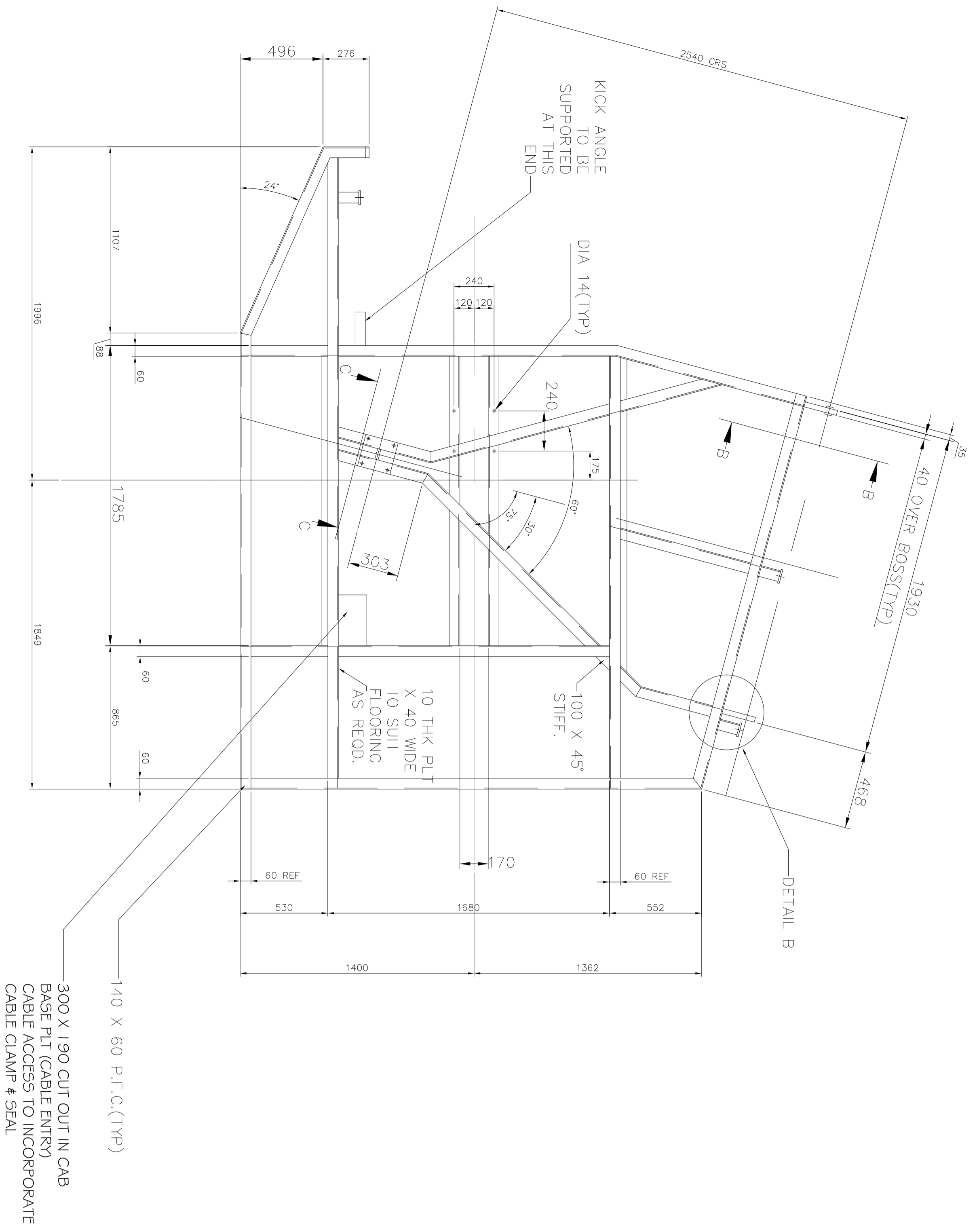

SECTION A-A
(SHEET 1)

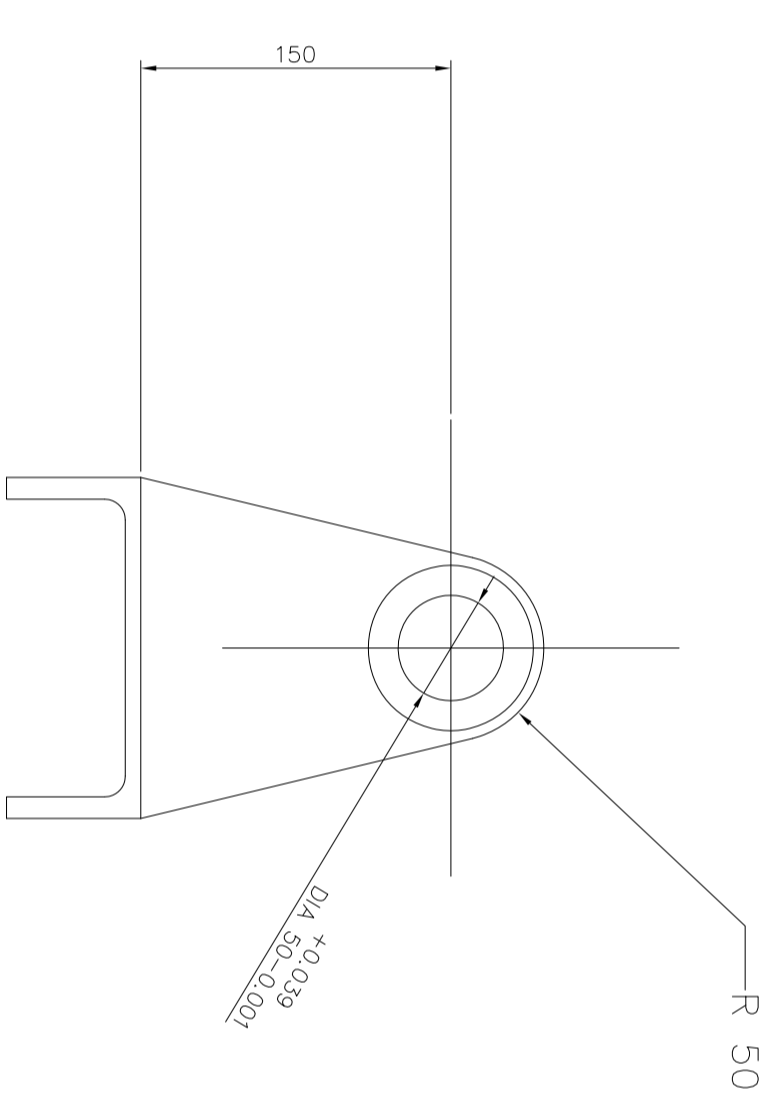

SECTION B-B
SCALE 1:5

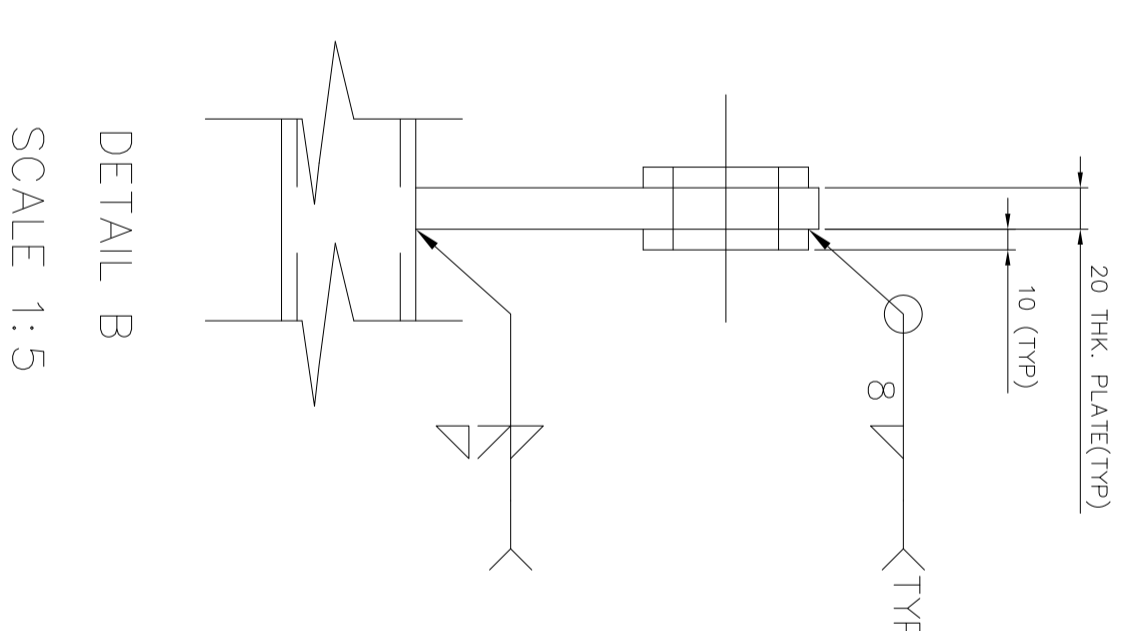

DETAIL B
SCALE 1:5

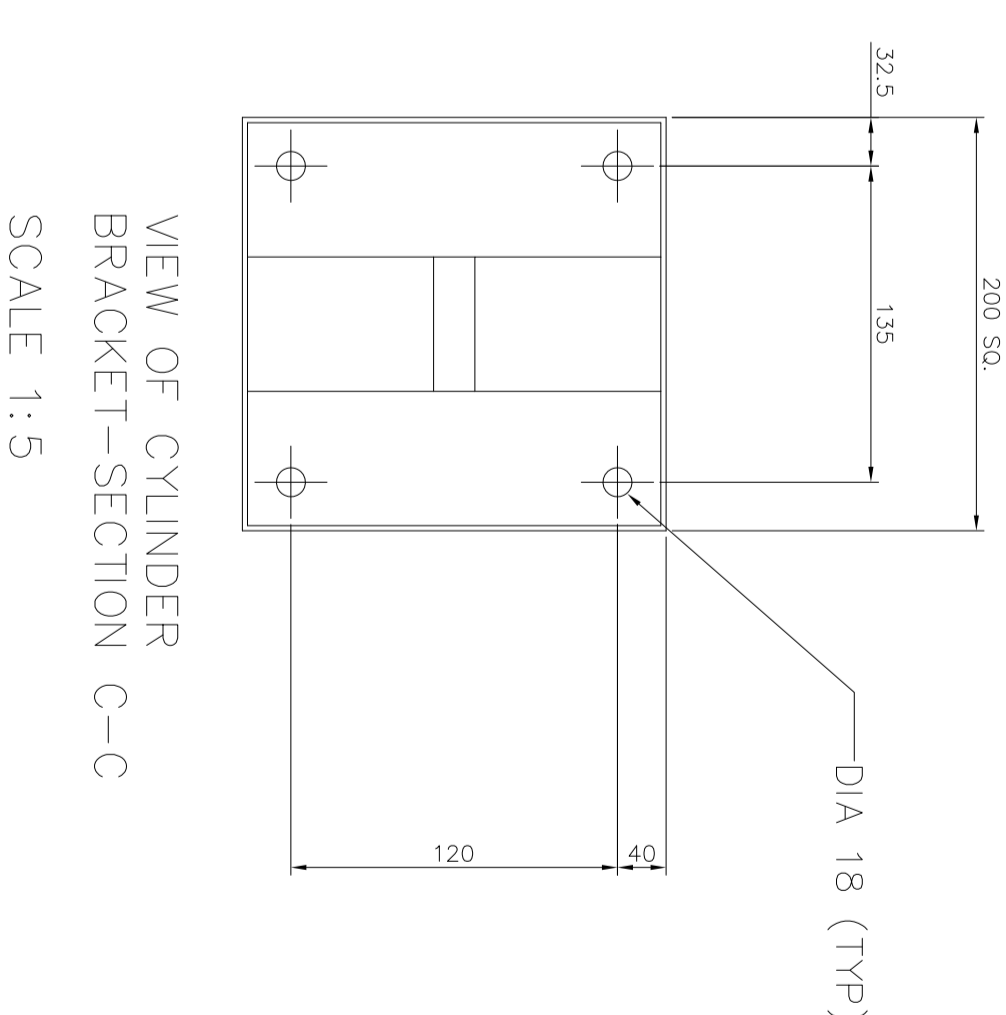

VIEW OF CYLINDER
BRACKET-SECTION C-C
SCALE 1:5

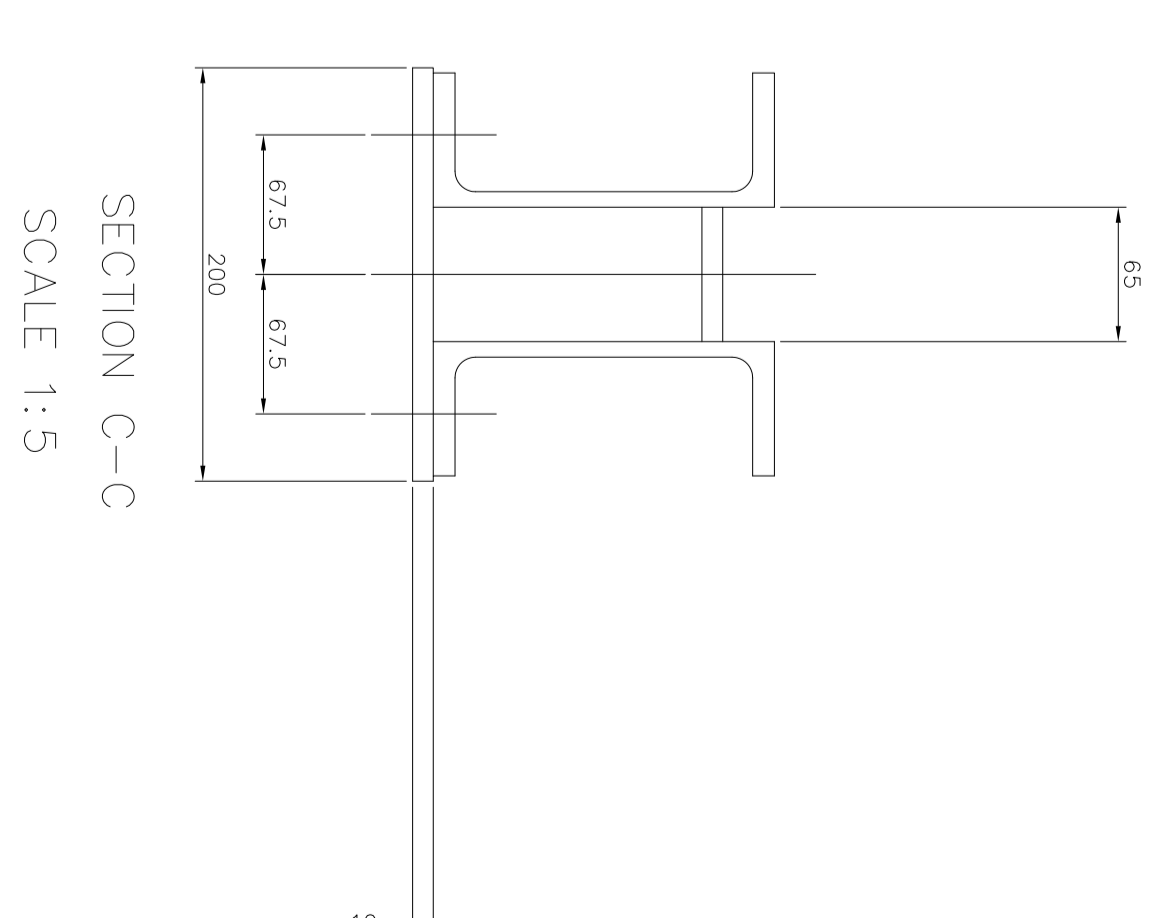

SECTION C-C
SCALE 1:5

ISSUED FOR APPROVAL
AS BUILT

AK
06/01/2003

Kg 1:20

SALDANHA STACKER RECLAIMER
ASSEMBLY AND DETAILS OF
OPERATORS CAB

700452

2 4 A

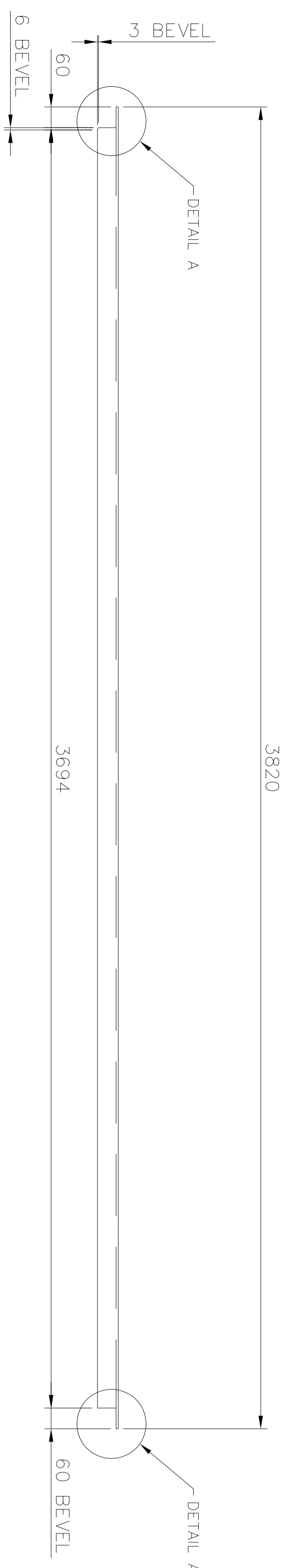

ONE 140 x 60 P.F.C. REOD. AS
DRAWN AND NOTED MARKED
"08"

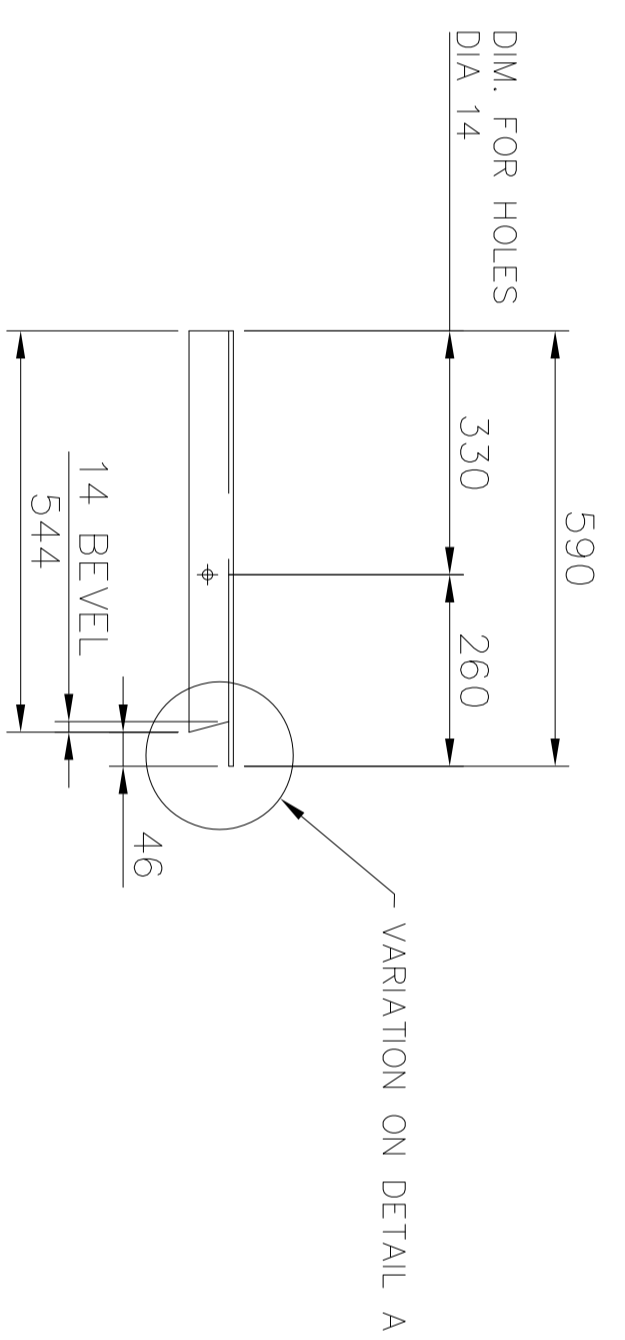

ONE 140 x 60 P.F.C. REOD. AS
DRAWN AND NOTED MARKED
"09"

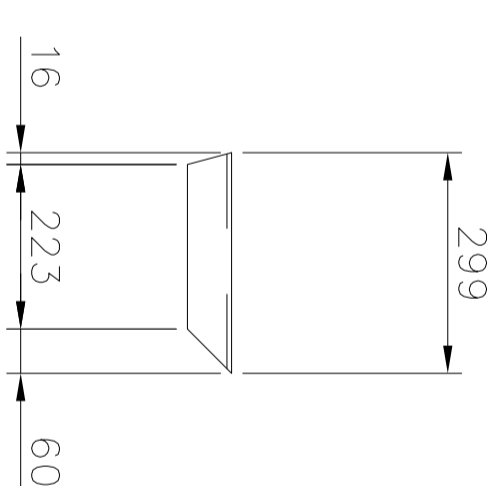

ONE 140 x 60 P.F.C. REOD. AS
DRAWN AND NOTED MARKED
"10"

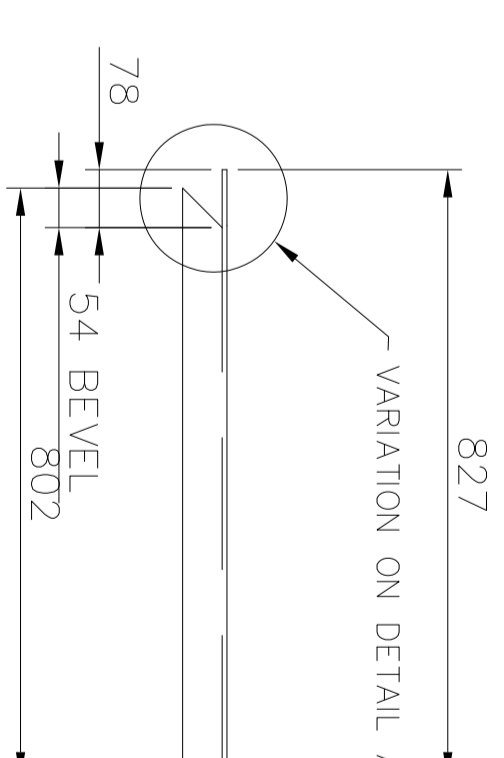

ONE 140 x 60 P.F.C. REOD. AS
DRAWN AND NOTED MARKED
"11"

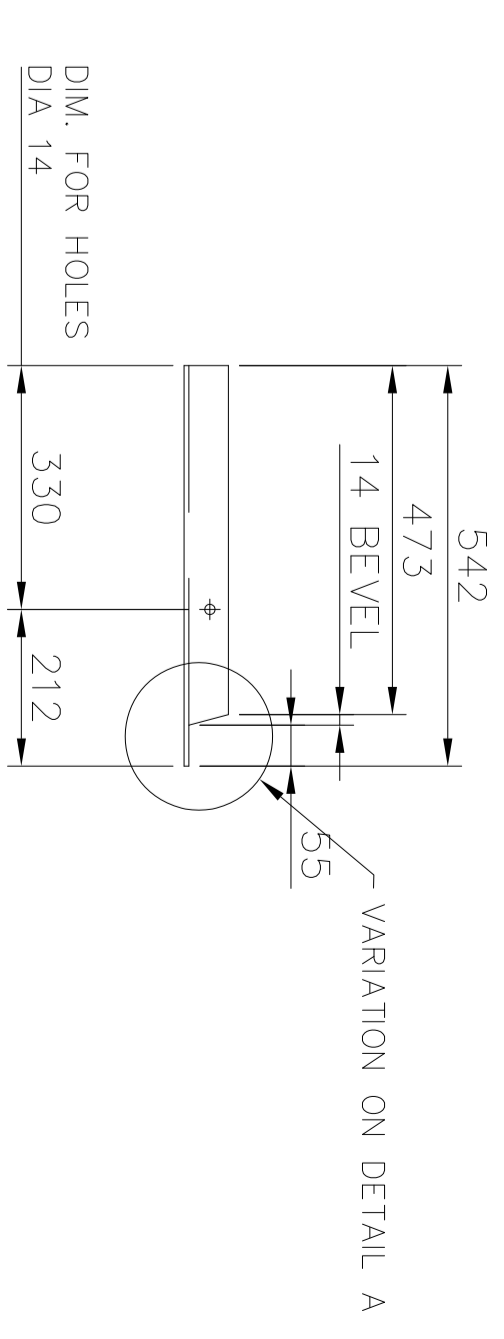

ONE 140 x 60 P.F.C. REOD. AS
DRAWN AND NOTED MARKED
"12"

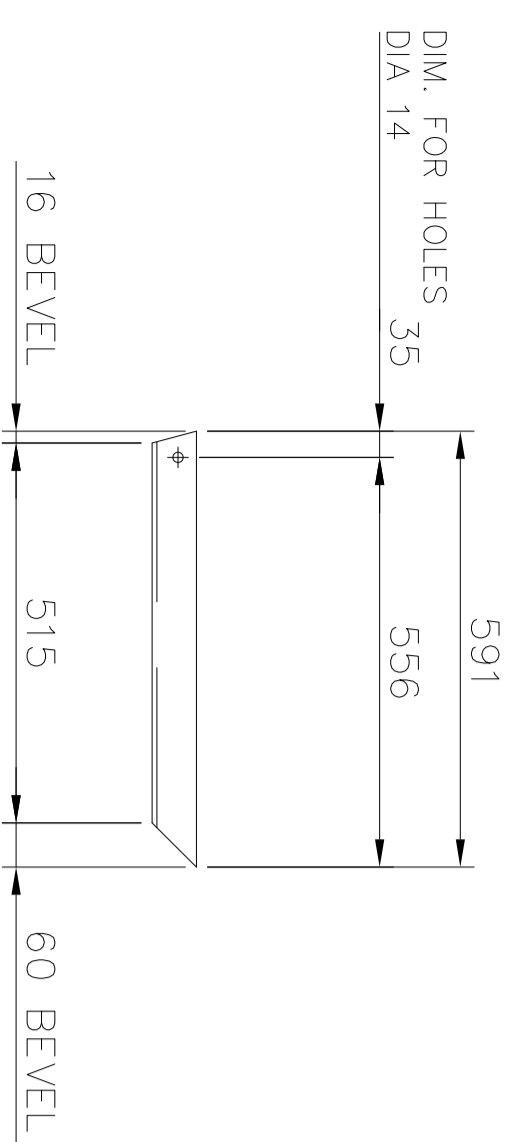

ONE 140 x 60 P.F.C. REOD. AS
DRAWN AND NOTED MARKED
"13"

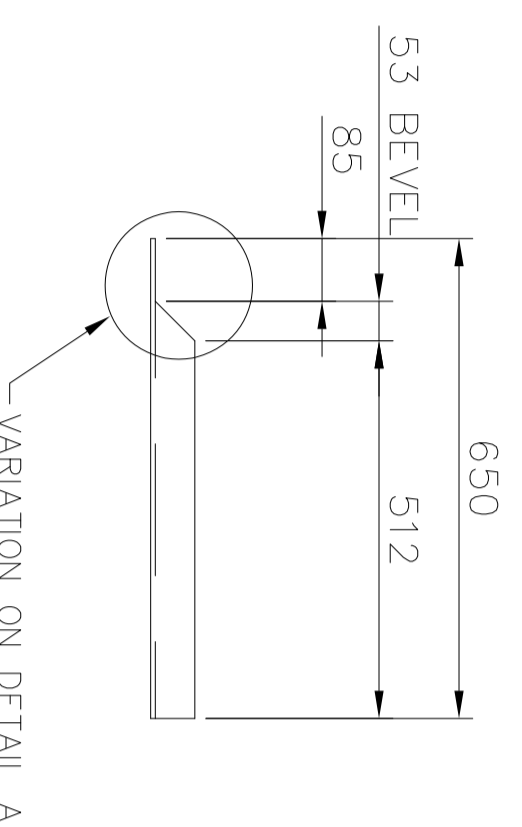

ONE 140 x 60 P.F.C. REOD. AS
DRAWN AND NOTED MARKED
"14"

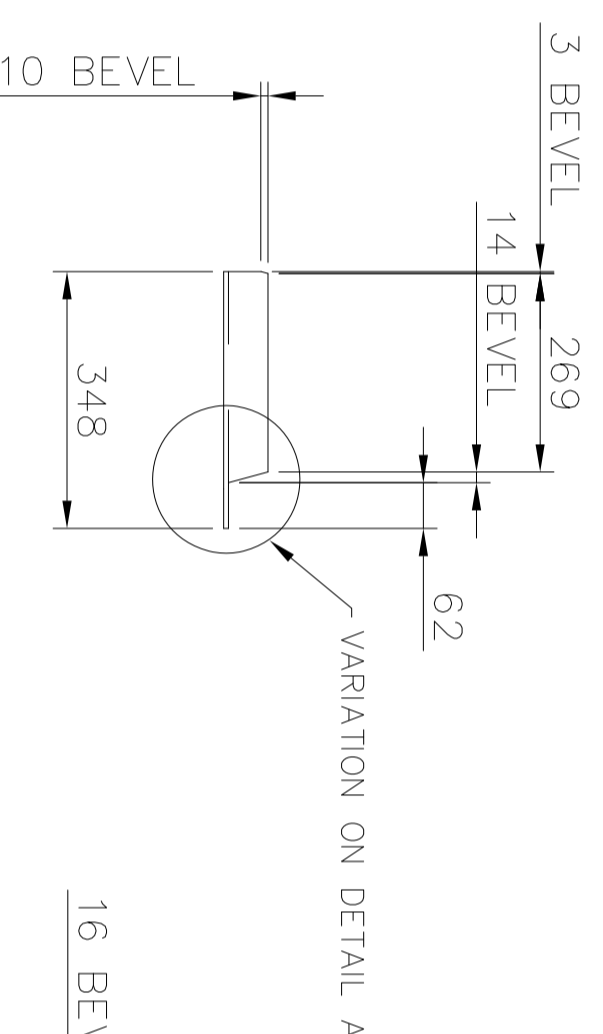

ONE 140 x 60 P.F.C. REOD. AS
DRAWN AND NOTED MARKED
"15"

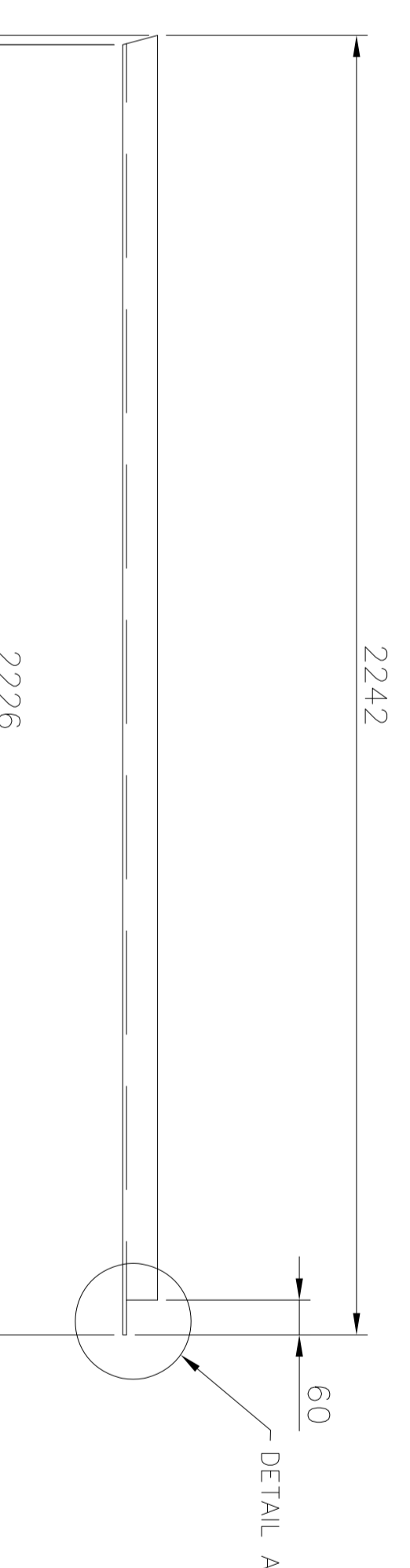

ONE 140 x 60 P.F.C. REOD. AS
DRAWN AND NOTED MARKED
"16"

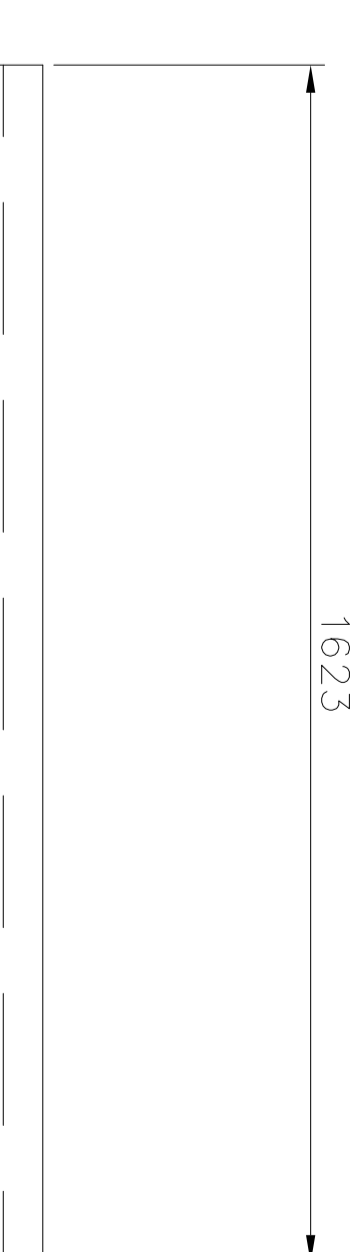

ONE 140 x 60 P.F.C. REOD. AS
DRAWN AND NOTED MARKED
"17"

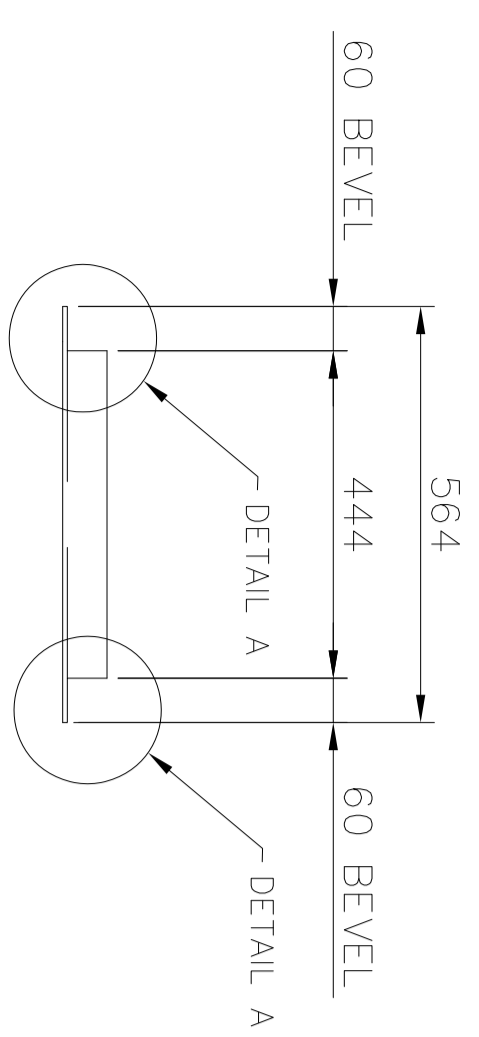

ONE 140 x 60 P.F.C. REOD. AS
DRAWN AND NOTED MARKED
"18"

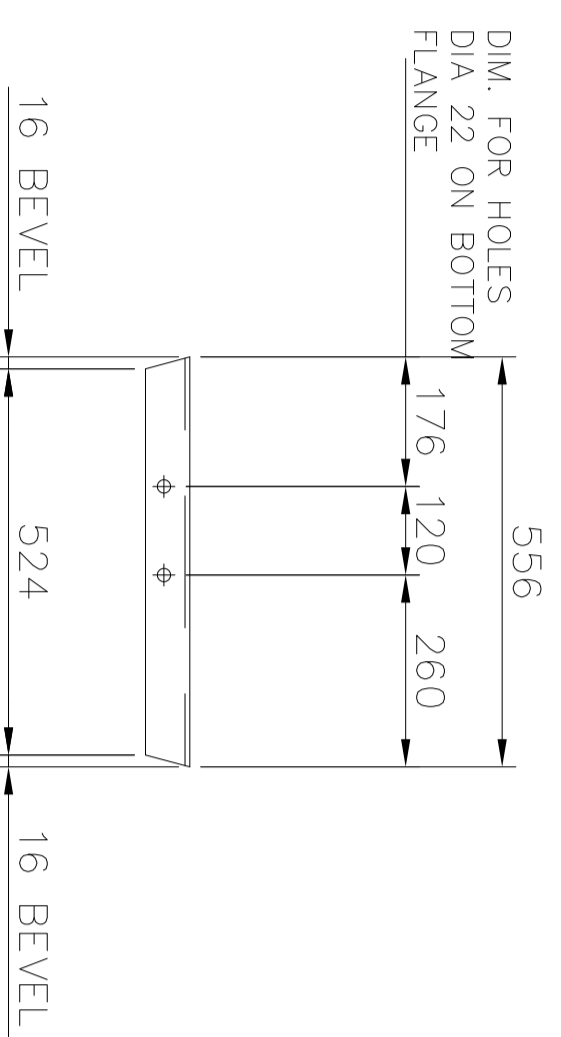

ONE 140 x 60 P.F.C. REOD. AS
DRAWN AND NOTED MARKED
"19"

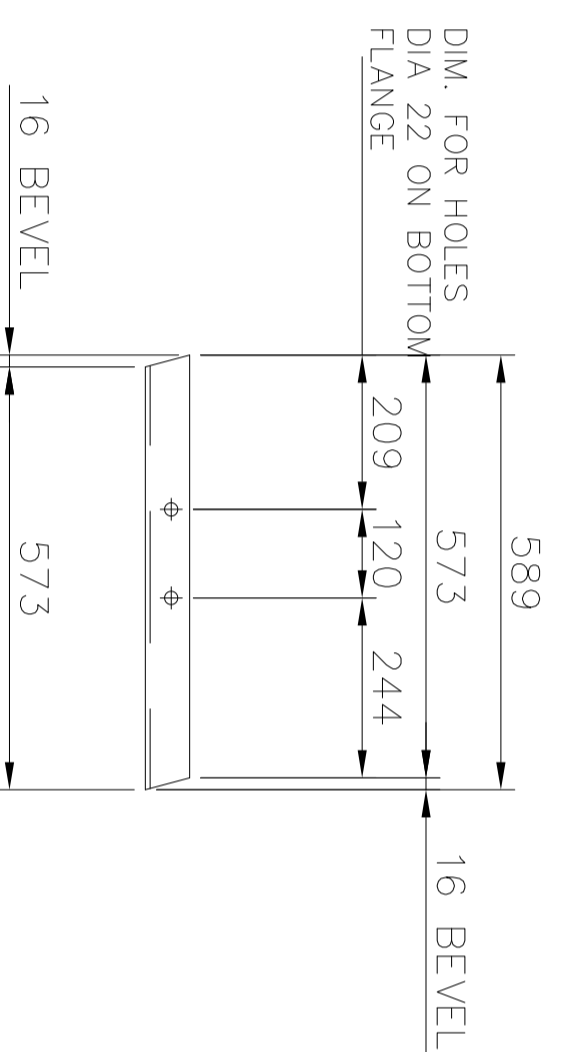

ONE 140 x 60 P.F.C. REOD. AS
DRAWN AND NOTED MARKED
"20"

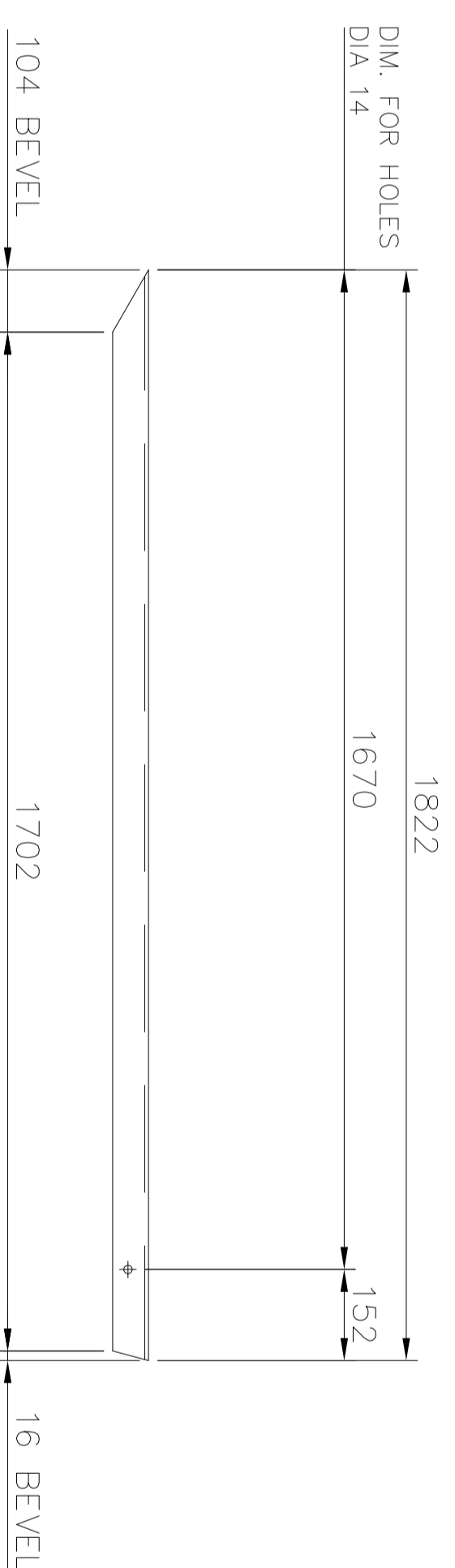

ONE 140 x 60 P.F.C. REOD. AS
DRAWN AND NOTED MARKED
"21"

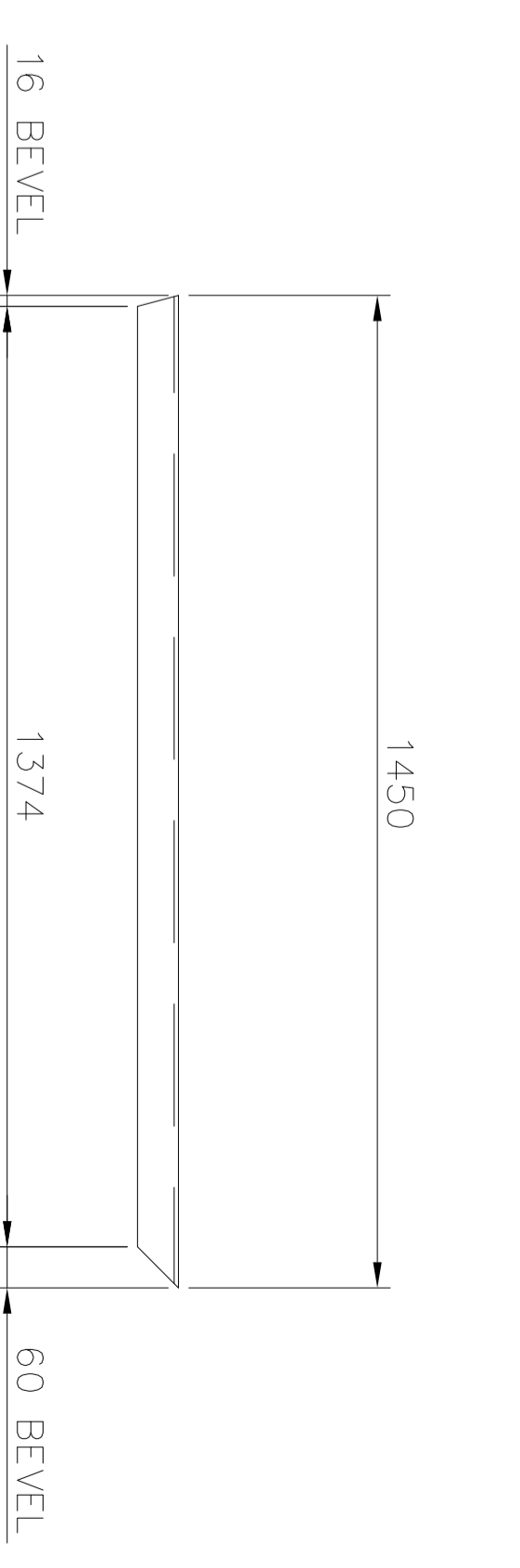

ONE 140 x 60 P.F.C. REOD. AS
DRAWN AND NOTED MARKED
"22"

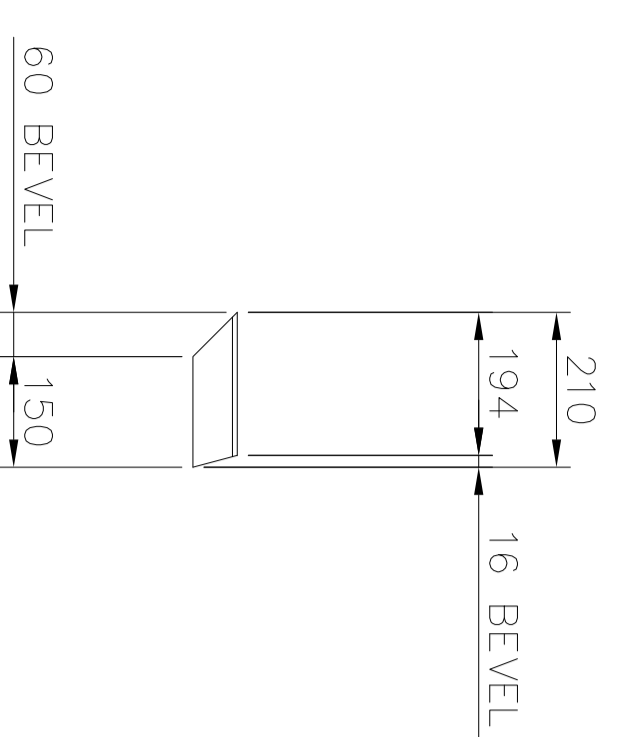

ONE 140 x 60 P.F.C. REOD. AS
DRAWN AND NOTED MARKED
"23"

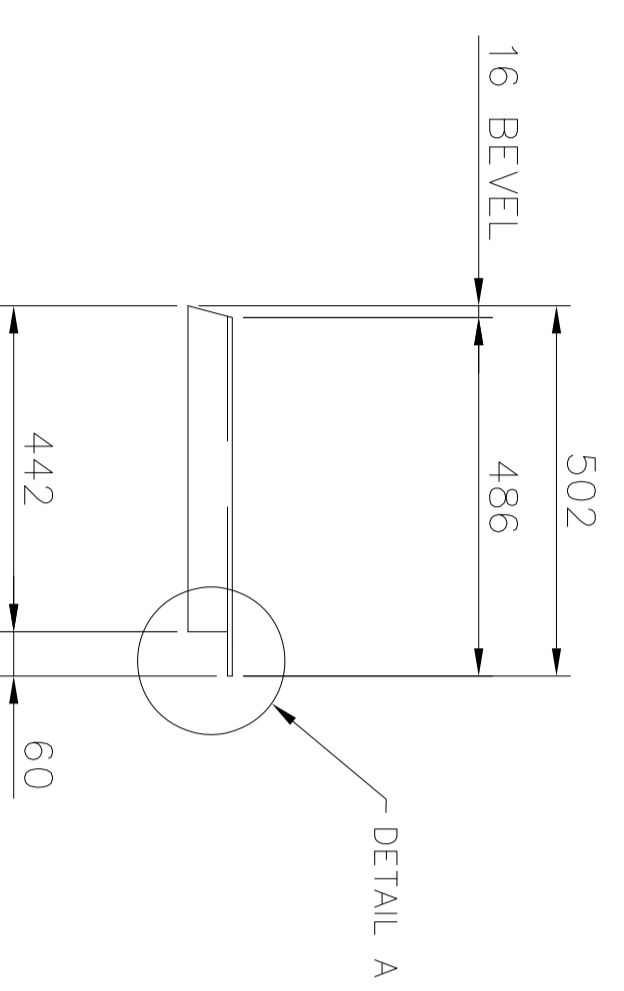

ONE 140 x 60 P.F.C. REOD. AS
DRAWN AND NOTED MARKED
"24"

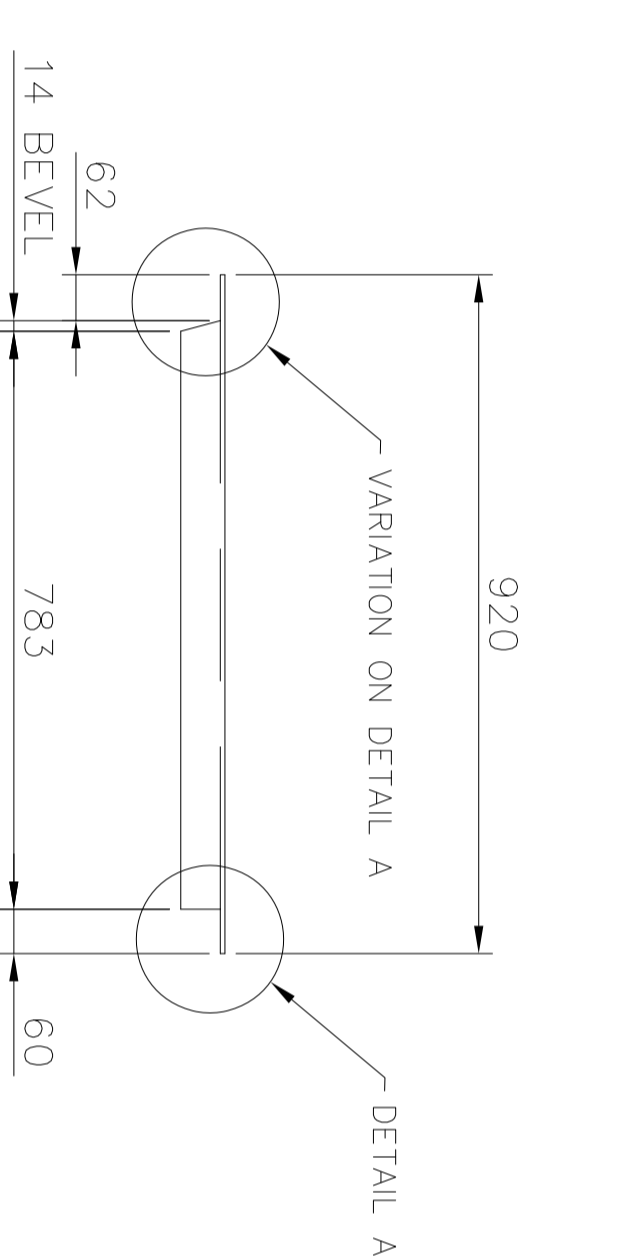

ONE 140 x 60 P.F.C. REOD. AS
DRAWN AND NOTED MARKED
"25"

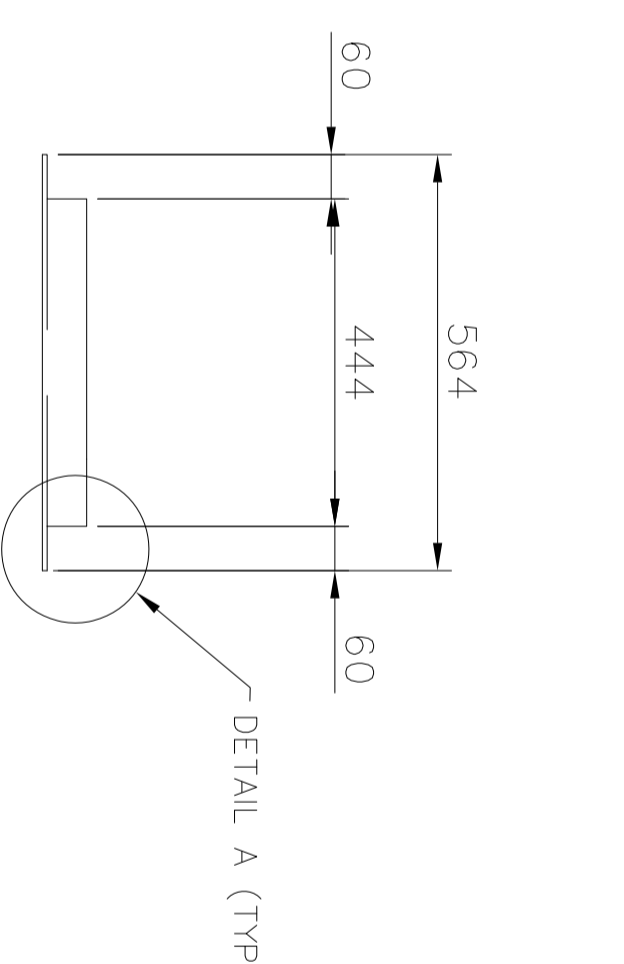

ONE 140 x 60 P.F.C. REOD. AS
DRAWN AND NOTED MARKED
"28"

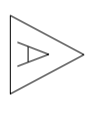
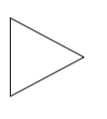
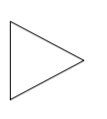
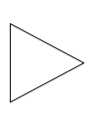
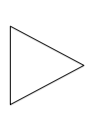
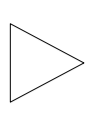

ISSUED FRO APPROVAL
AS BUILT

AK

31/03/2003

Kg 1:10

700452

3 4 A

SALDANHA STACKER RECLAIMER
ASSEMBLY AND DETAILS OF
OPERATORS CAB

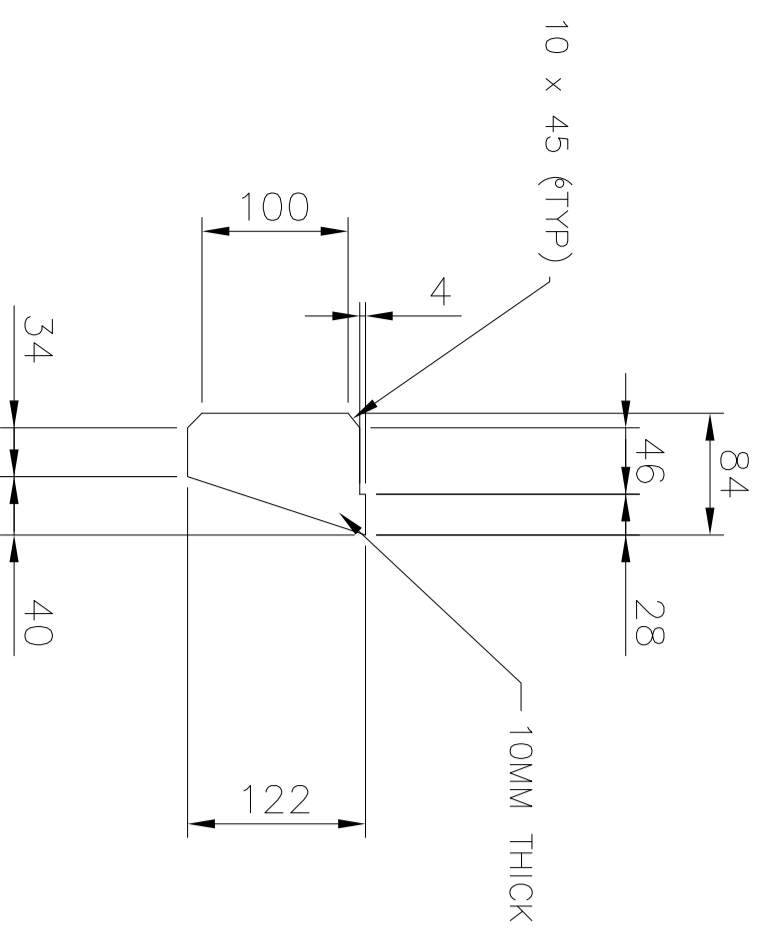
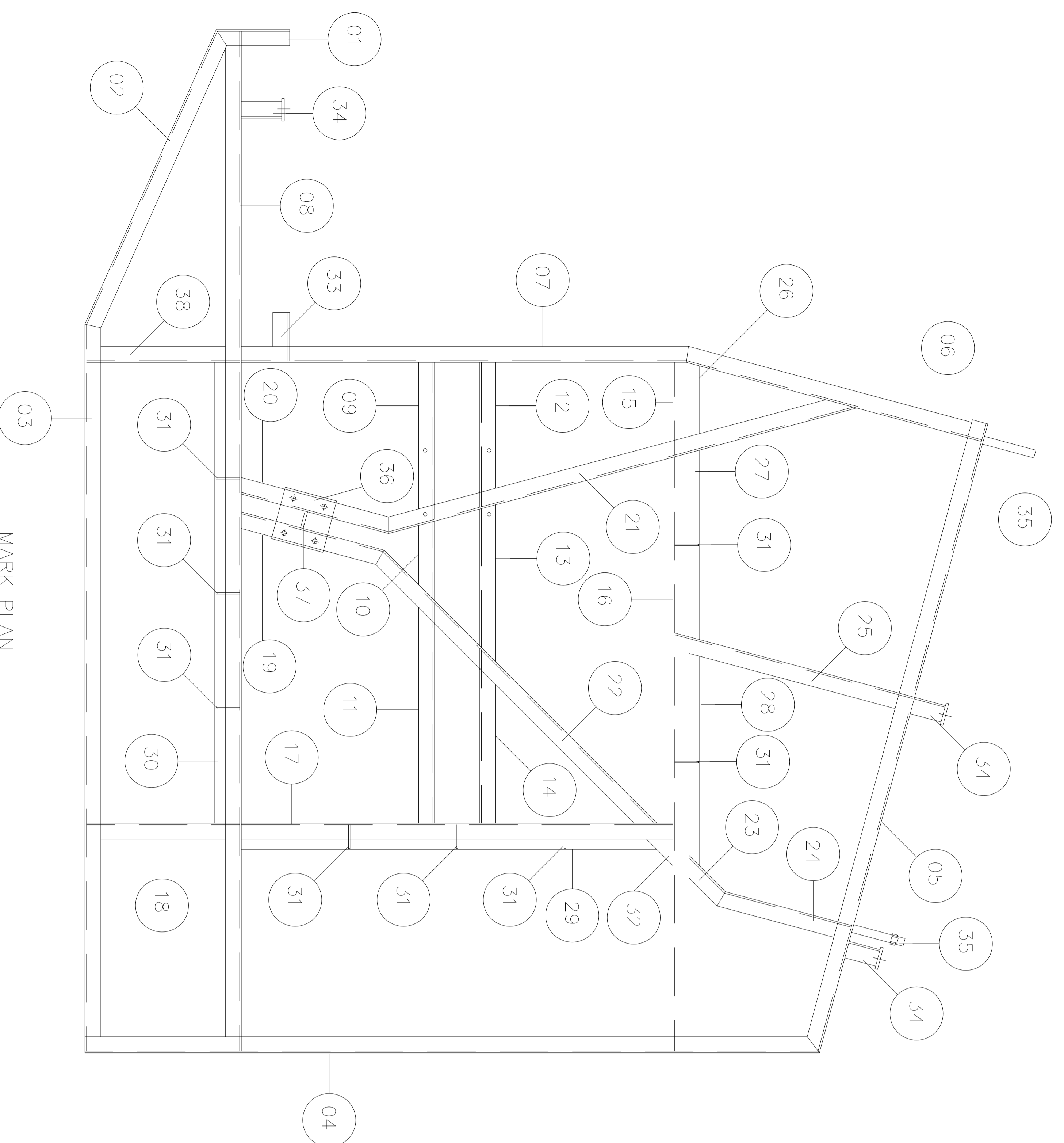

EIGHT STIFFENER PLATES REQD.
AS DRAWN AND NOTED MARKED
"31"

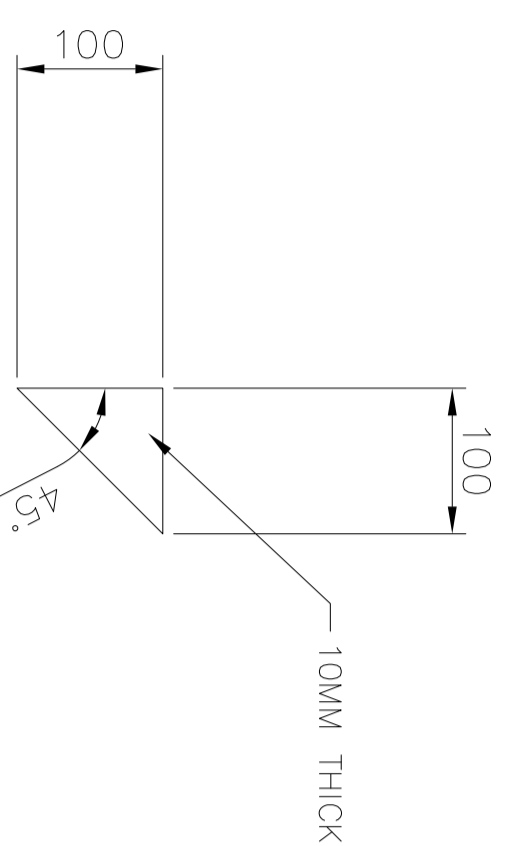
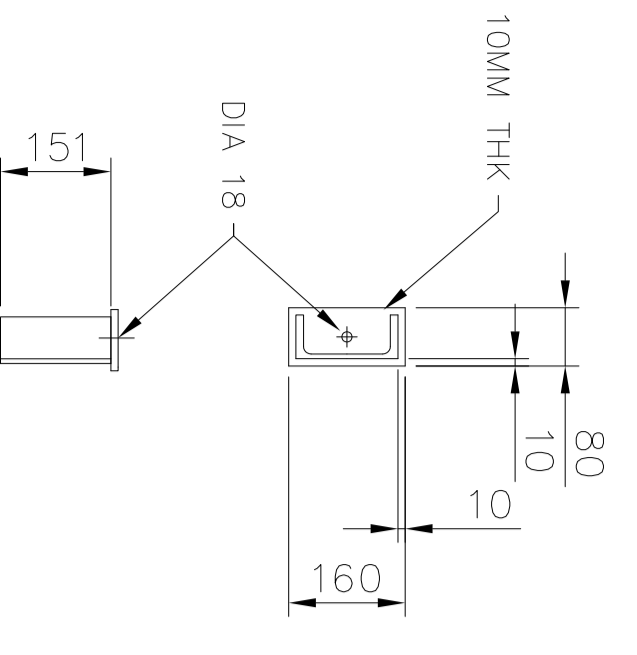

ONE STIFFENER PLATE REQD.
AS DRAWN AND NOTED MARKED
"32"

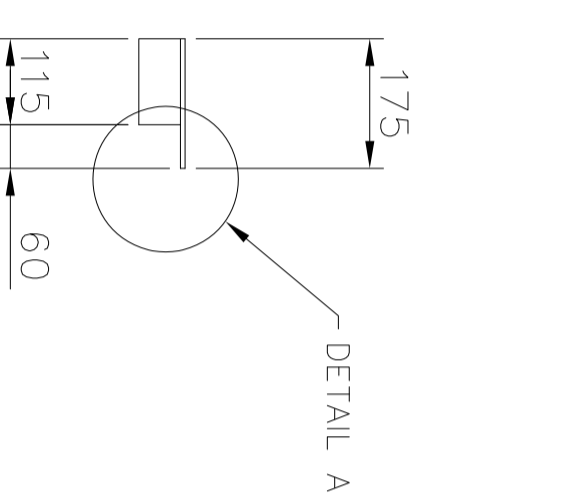
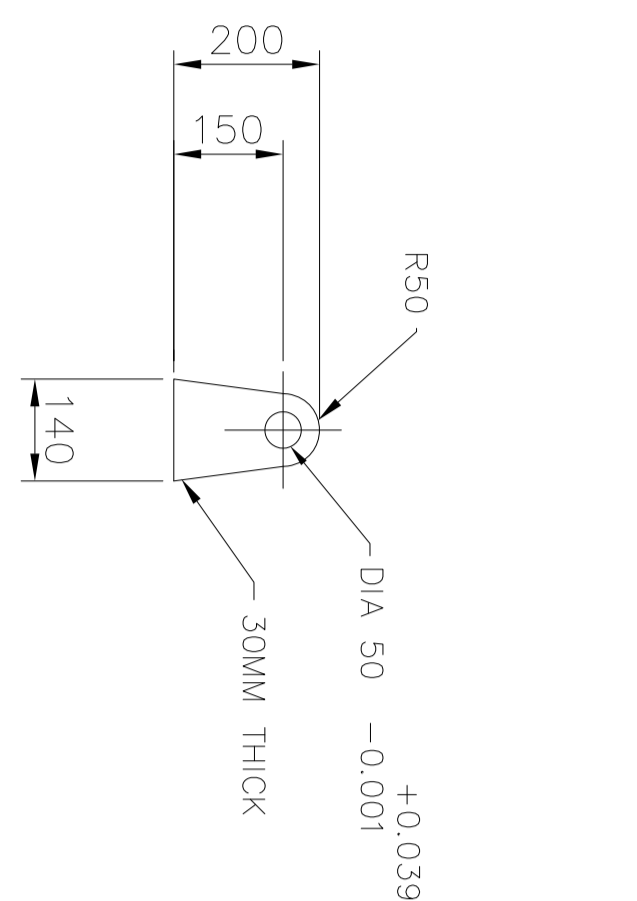

ONE 140 x 60 P.F.C. REQD.
AS DRAWN AND NOTED MARKED
"33"

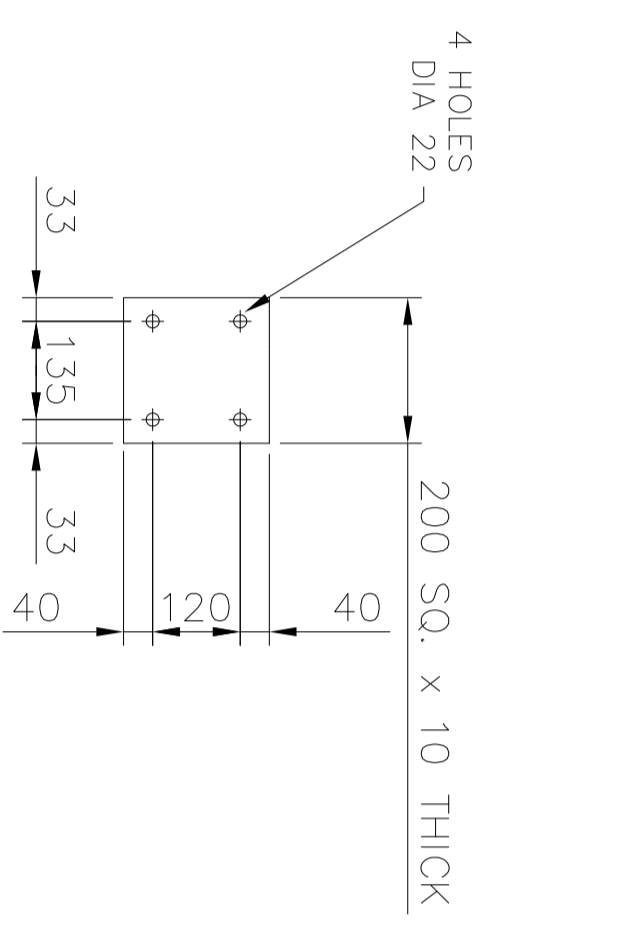

THREE 140 x 60 P.F.C. REQD.
AS DRAWN AND NOTED MARKED
"34"

TWO PLATES REQD. AS DRAWN
AND NOTED MARKED "35"

ONE PLATE REQD. AS DRAWN
AND NOTED MARKED "36"

ONE STIFFENER PLATE REQD.
AS DRAWN AND NOTED MARKED
"37"

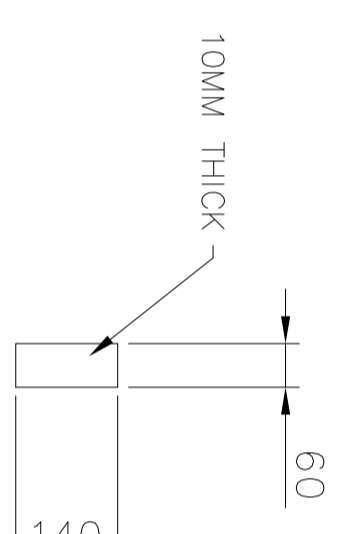

ONE 140 x 60 P.F.C. REQD. AS
DRAWN AND NOTED MARKED
"07"

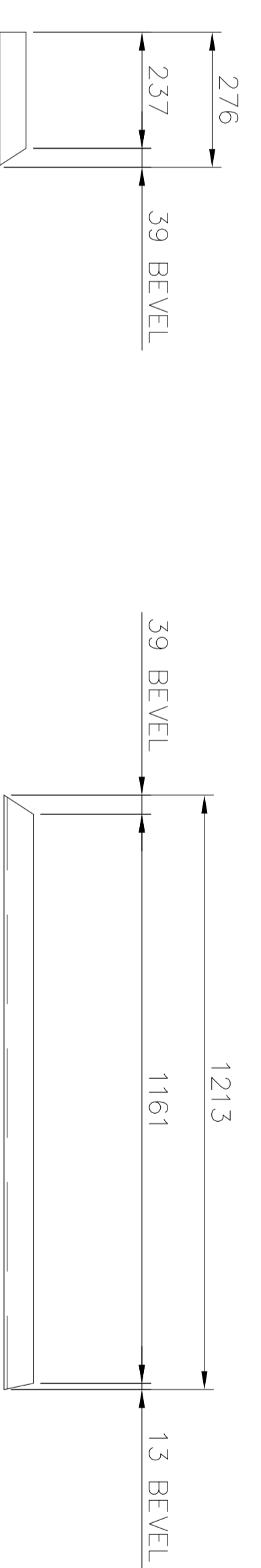

ONE 140 x 60 P.F.C. REQD. AS
DRAWN AND NOTED MARKED
"01"

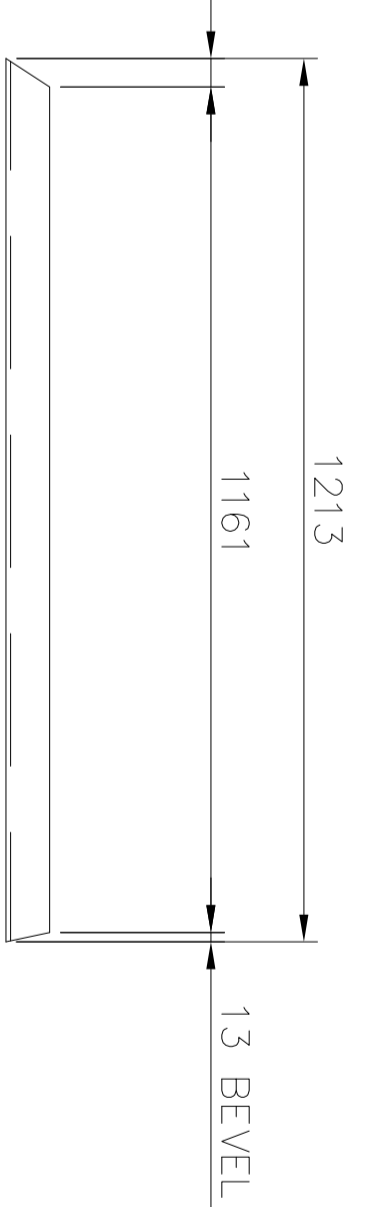

ONE 140 x 60 P.F.C. REQD. AS
DRAWN AND NOTED MARKED
"02"

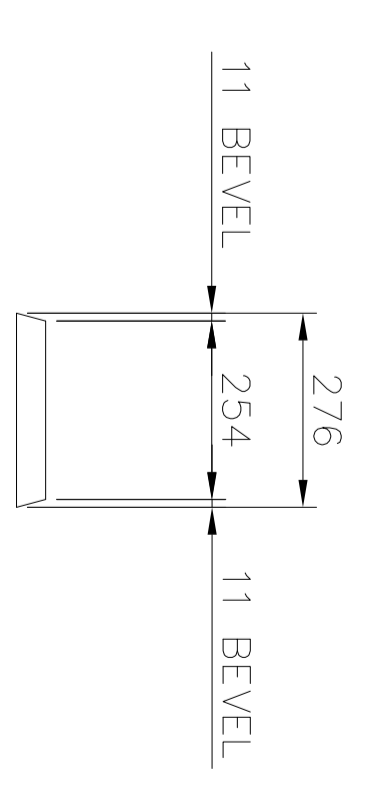

ONE 40 x 8 THK FLAT BAR
REQD. AS DRAWN AND NOTED
MARKED "26"

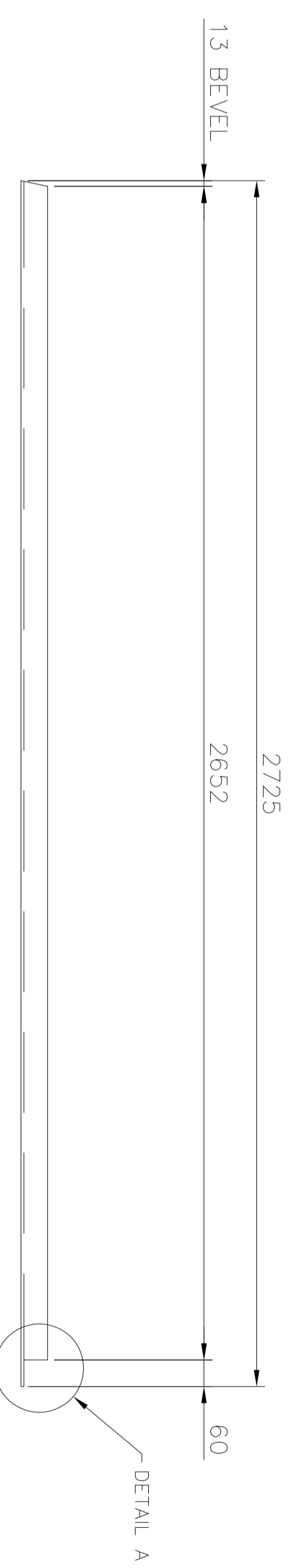

ONE 140 x 60 P.F.C. REQD. AS
DRAWN AND NOTED MARKED
"03"

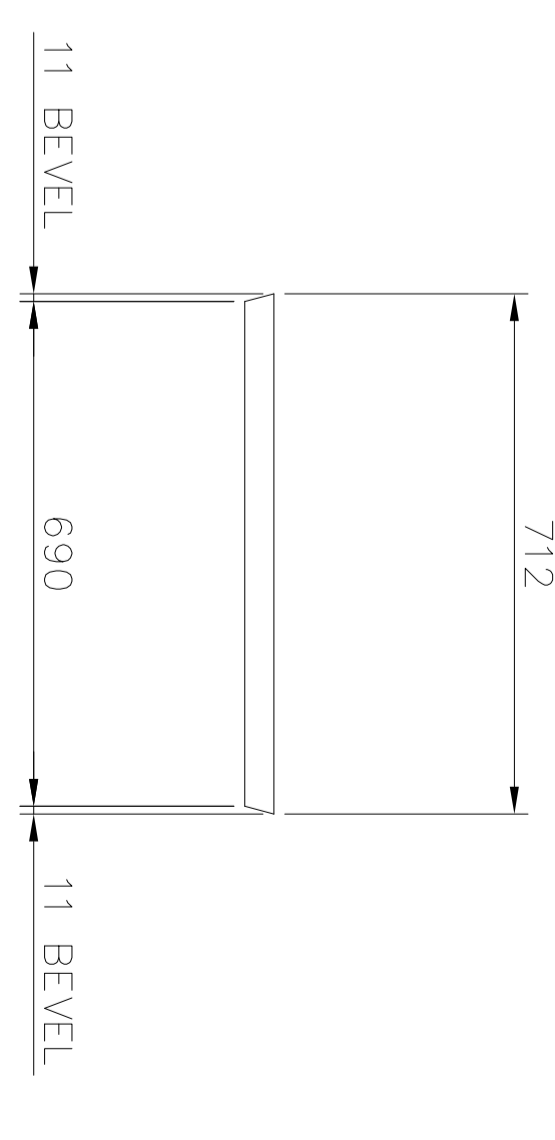

ONE 40 x 8 THK FLAT BAR
REQD. AS DRAWN AND NOTED
MARKED "27"

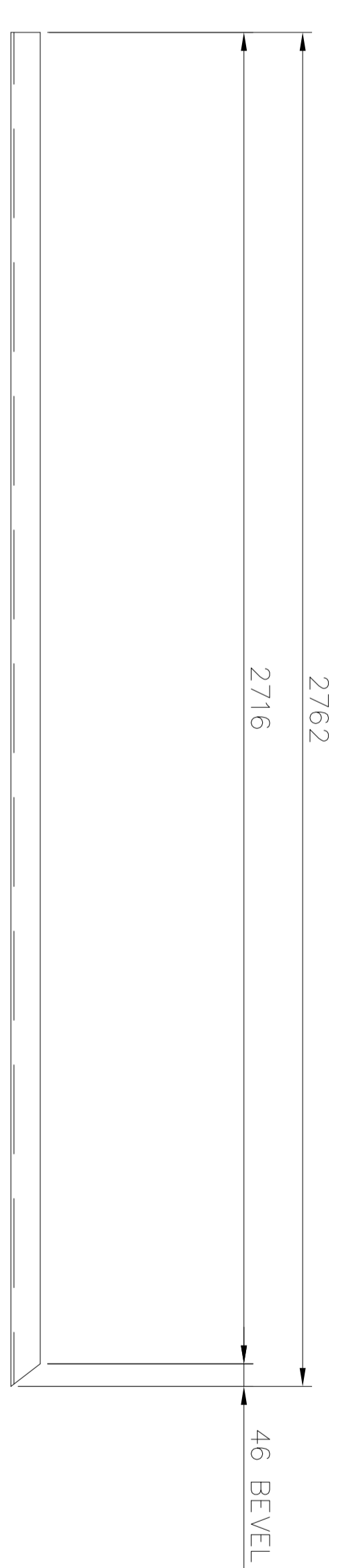

ONE 140 x 60 P.F.C. REQD. AS
DRAWN AND NOTED MARKED
"04"

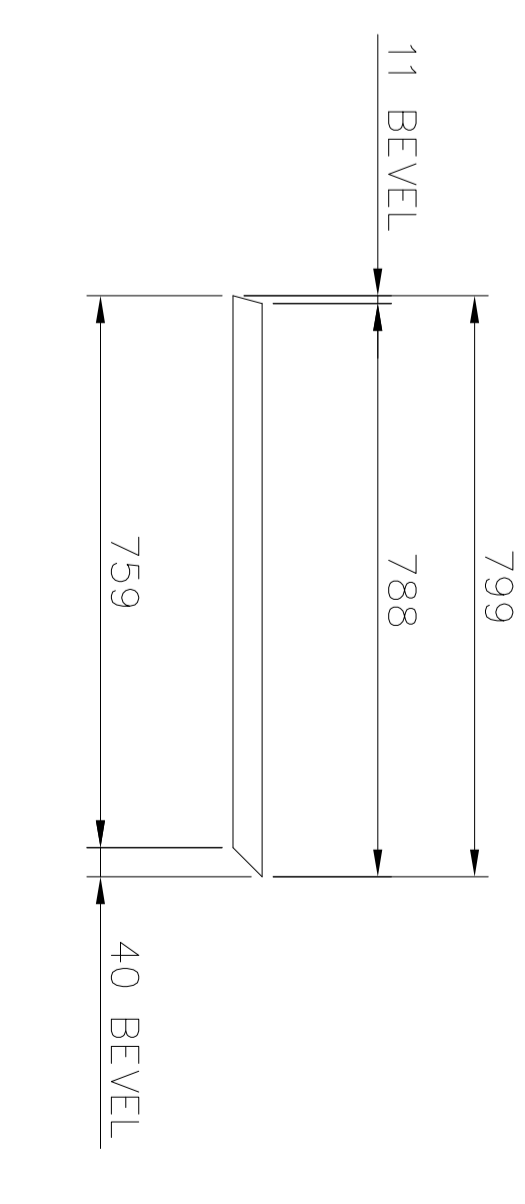

ONE 40 x 8 THK FLAT BAR
REQD. AS DRAWN AND NOTED
MARKED "28"

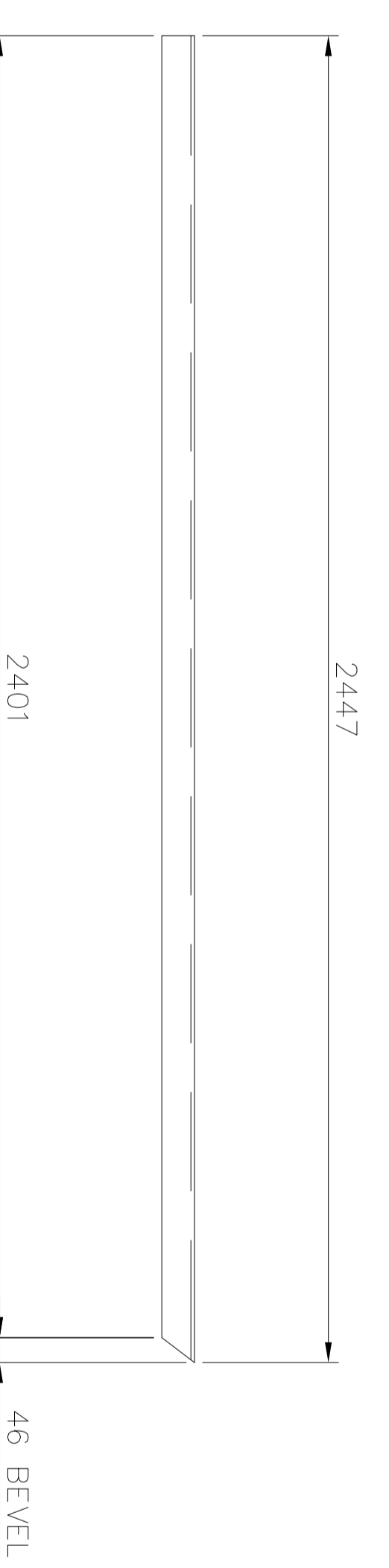

ONE 140 x 60 P.F.C. REQD. AS
DRAWN AND NOTED MARKED
"05"



ONE 40 x 8 THK FLAT BAR
REQD. AS DRAWN AND NOTED
MARKED "29"

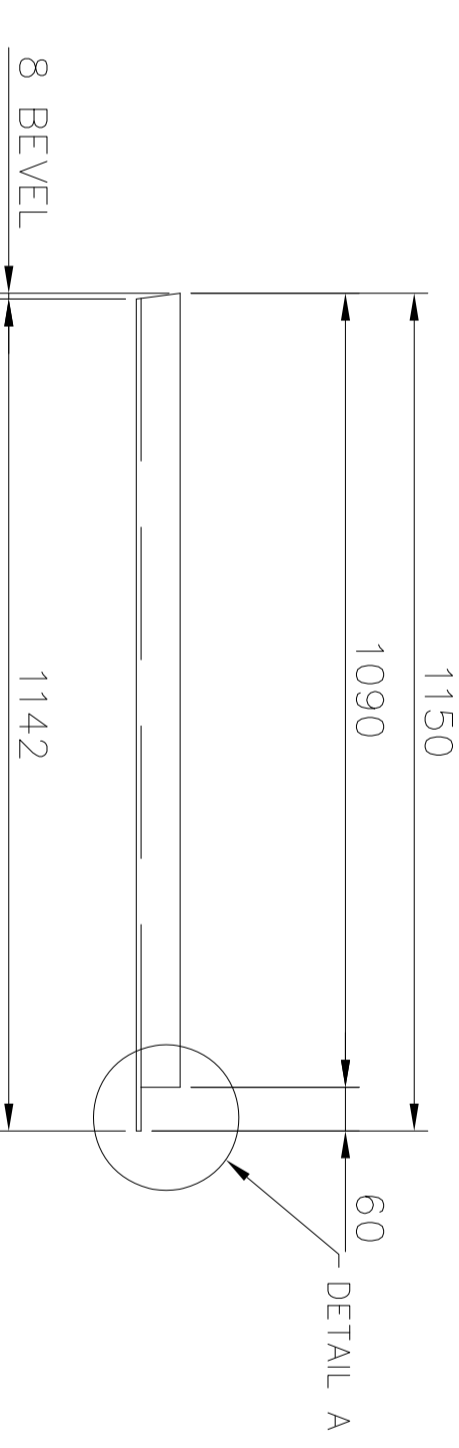

ONE 140 x 60 P.F.C. REQD. AS
DRAWN AND NOTED MARKED
"06"

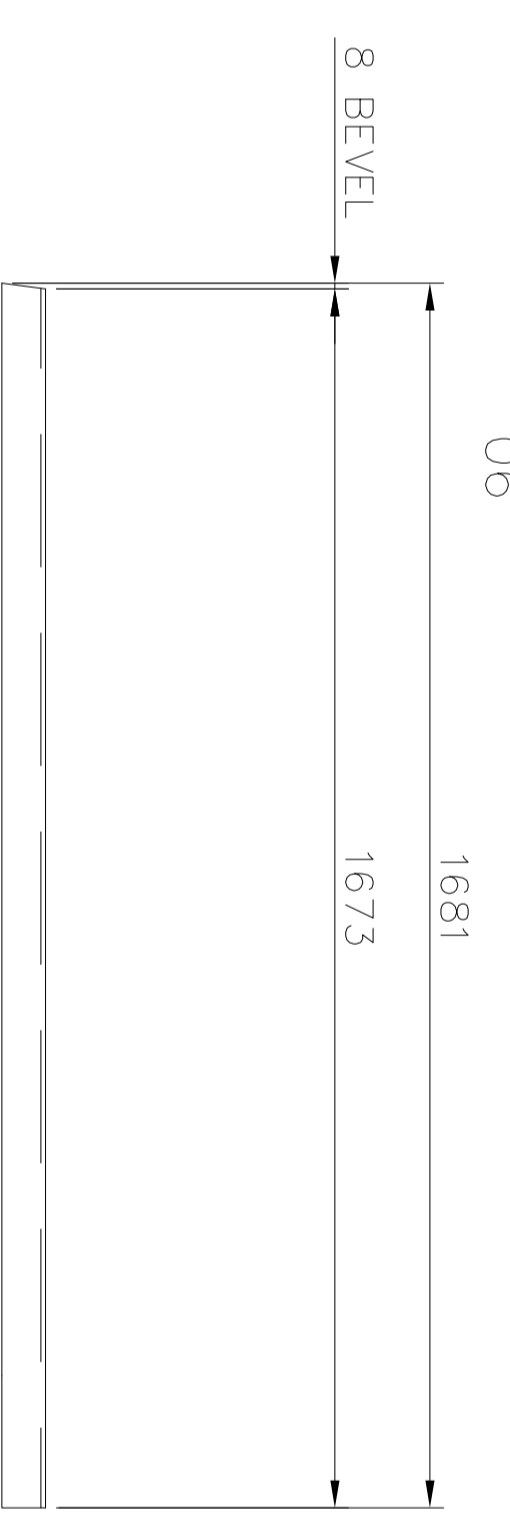

ONE 140 x 60 P.F.C. REQD. AS
DRAWN AND NOTED MARKED
"07"

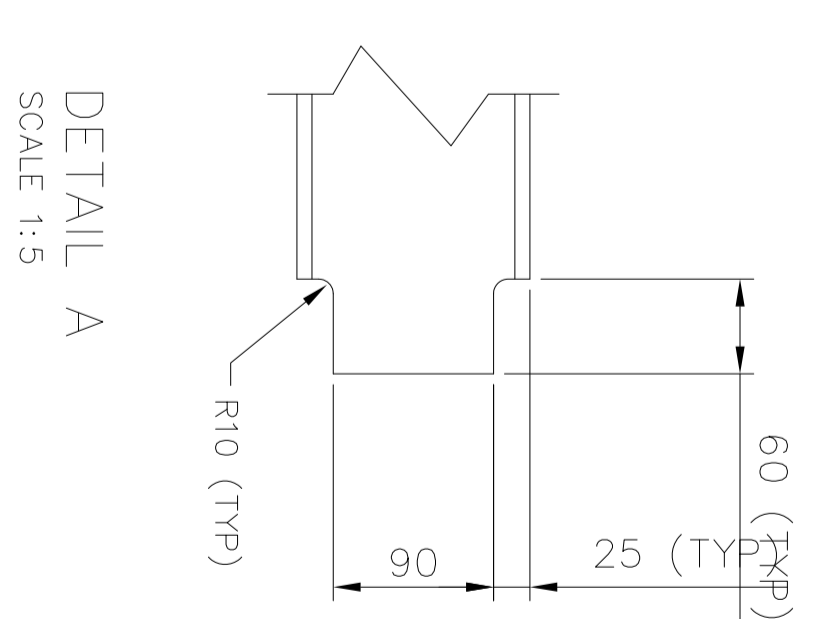

ONE 40 x 8 THK FLAT BAR
REQD. AS DRAWN AND NOTED
MARKED "30"

ISSUED FOER APPROVAL
AS BUILT

SALDANHA STACKER RECLAIMER
ASSEMBLY AND DETAILS OF
OPERATORS CAB

AK

Kg 1:10

700452

4 4 A

02/04/2003

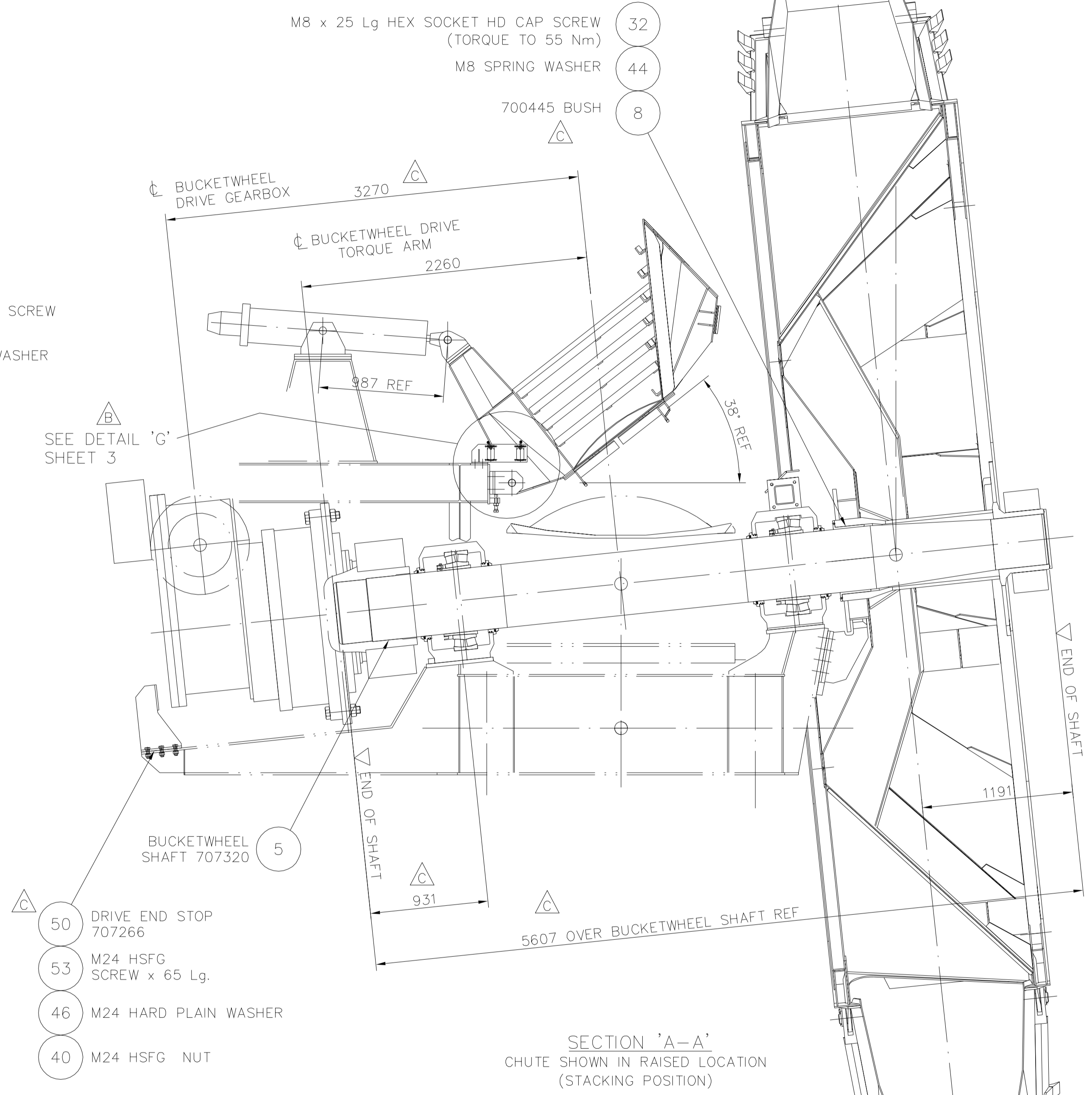
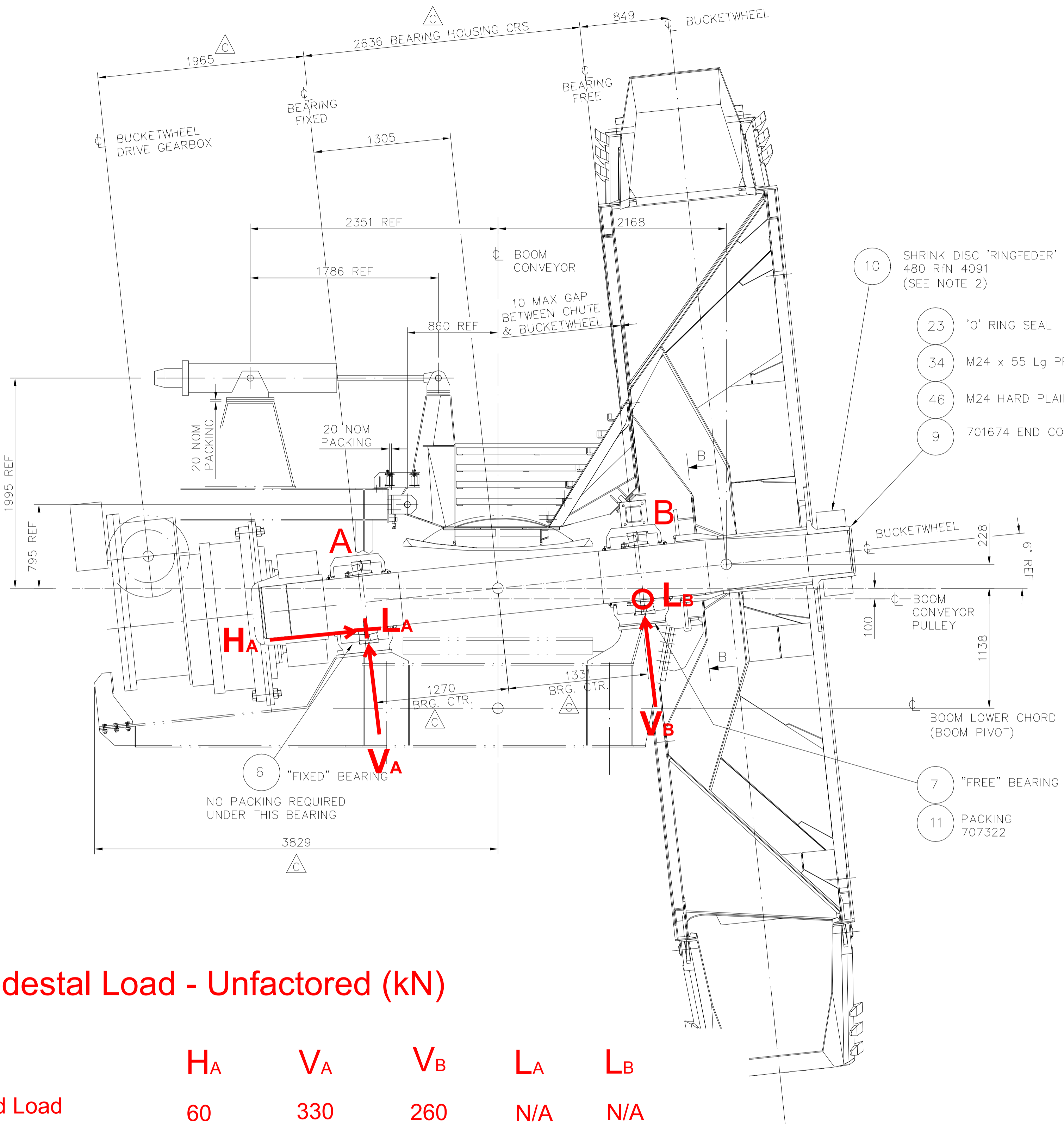

Pedestal Load - Unfactored (kN)

	H_A	V_A	V_B	L_A	L_B
Dead Load	60	330	260	N/A	N/A
Operational Loads	110	250	500	25	95
Abnormal Loads	180	110	860	65	240

DRAWN			CHECKED			APPROVED			DRAWN			CHECKED			APPROVED			DRAWN			CHECKED			APPROVED		
DATE			DATE			DATE			DATE			DATE			DATE			DATE			DATE			DATE		
13 FEB 2008			28 FEB 2008			28 FEB 2008			3-3-03			3-3-03			3-3-03			10/7/02			26/9/02			08/10/02		
NEW B/W DRIVE ASSY ITEMS 4-8, 12, 20 & 36 REPLACED ITEMS 14 & 15 MODIFIED HUB ON BUCKETWHEEL MODIFIED. BOOM MODIFIED NEW ITEM 50 REPLACES FIXED END STOP									BUCKETWHEEL CHUTE RAISED & LOWERED LIMIT SWITCHES ADDED SEE SHTS 2 & 3.									FIRST ISSUE								

UNLESS OTHERWISE SPECIFIED IDENTIFY THE ITEM WITH THE DRAWING NUMBER AND ISSUE LEVEL AT AND IN THE MANNER SHOWN FOR PAINTING AND FOR LUBRICATION SPECIFICATIONS SEE COMPONENTS LIST.

UNLESS OTHERWISE STATED DIMENSIONS ARE IN MILLIMETRES. TOLERANCES UNLESS OTHERWISE STATED (PLUS OR MINUS)

RANGE	MACH	FAB	CAST
0-500	0.25	2	2
501-1000	0.5	3	4
1001-2000	1.0	4	6
ABOVE 2000	2.0	6	10

This print and all the information hereon is the property of Metso Minerals, Bulk Materials Handling Bristol and must not be made public, copied or used in any way detrimental to our interest. It is loaned subject to return on demand, unless furnished under contract provisions.

**DO NOT SCALE
IF IN DOUBT - ASK**

SOUTH AFRICAN PORT OPERATIONS
IRON ORE TERMINAL - SALDANHA
STACKER RECLAIMER CONTRACT HQH375
SANCTION No. SB01 D1

**metso
minerals**

METSO MINERALS (UK Ltd)
BULK MATERIALS HANDLING BRISTOL
PO BOX 821 ASHTON VALE RD
BRISTOL BS99 5ZB ENGLAND

TITLE
**SALDANHA BAY STACKER RECLAIMER
ASSEMBLY OF BUCKETWHEEL
END OF BOOM**

MASS 54180 kg	ORIGINAL SCALE 1:25	SIZE A1	DRAWING NUMBER 700454	SHEET 2	OF 3	ISSUE C
------------------	------------------------	------------	--------------------------	------------	---------	------------

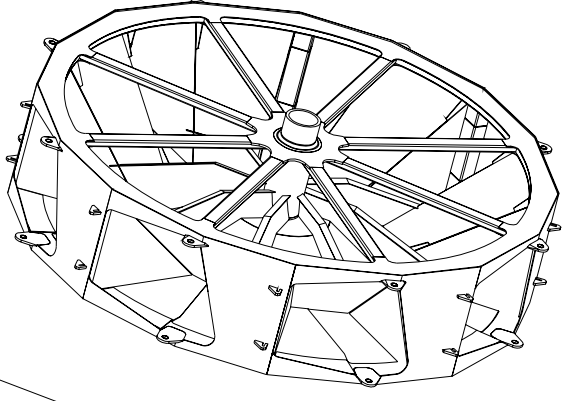
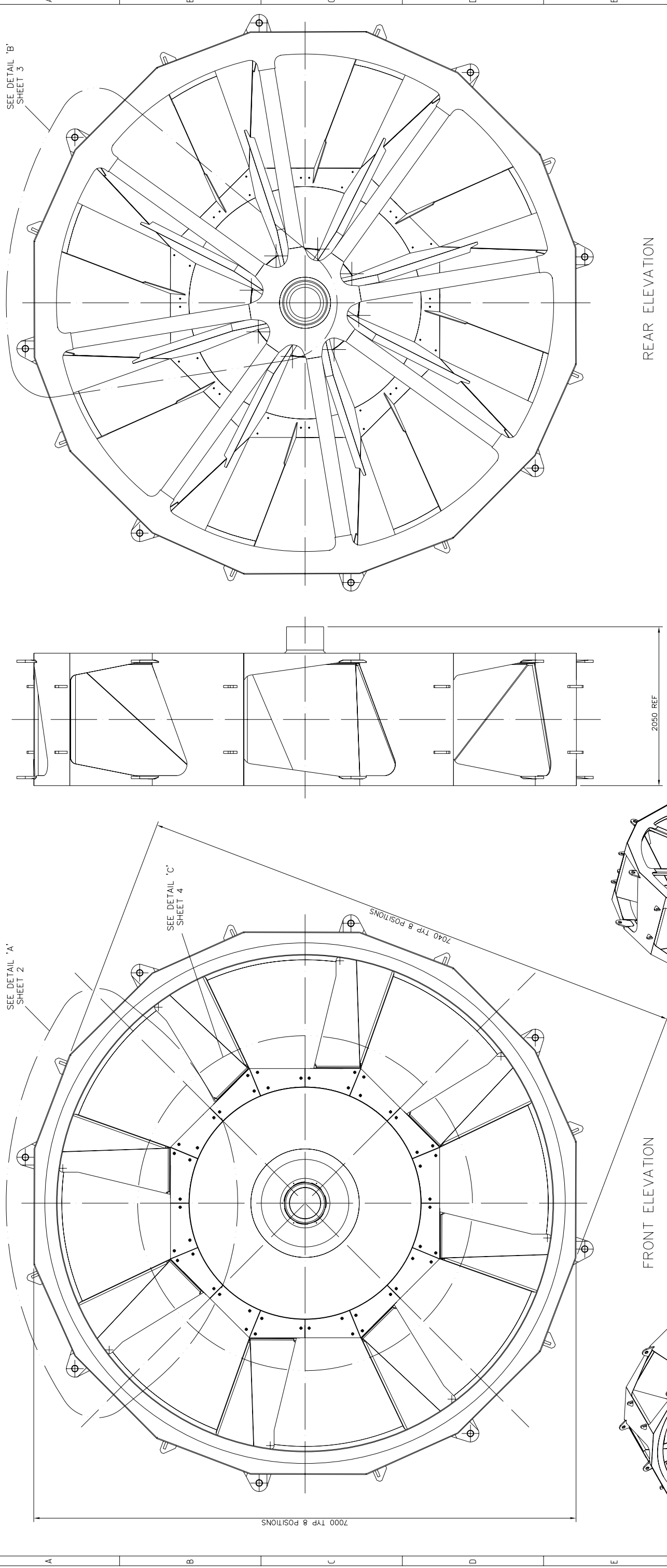

FRONT ISOMETRIC VIEW

REAR ISOMETRIC VIEW

GENERAL NOTES: -
 THIS DRAWING TO BE READ IN CONJUNCTION WITH :-
 700456, ASSEMBLY & DETAILS OF BUCKET (SHOP TRIAL ASSEMBLE ALL BUCKETS TO WHEEL STRUCTURE & MATCH MARK).
 27496/D15, MANUFACTURING SPECIFICATION.

1. BUCKETWHEEL CONSISTS OF 8 IDENTICAL CELLS (ROTATIONAL SYMMETRY)
2. BUCKETWHEEL TO BE MADE FROM STEEL TO SABS1431 300WA (MIN YIELD STRESS = 300 N/mm²).
3. WEAR PLATES & CELL CLOSING PLATES MADE FROM VRN 500.
4. CELLS LINED WITH HIGH DENSITY WEAR RESISTANT ALUMINA CERAMIC TILES USING HIGH STRENGTH TWO COMPONENT EPOXY RESIN ADHESIVE CEMENT (SEE SHEET 5).
5. HUB 'A' FROM CAST STEEL TO BS3100 GRADE A5, MIN YIELD STRESS = 370 N/mm² OR EQUIVALENT & ULTRASONICALLY TESTED TO INSPECTION PLAN.
6. HUB 'B' FROM BS970 070M20 OR EQUIVALENT.
7. WELDING.
8. TO CONFORM TO THE REQUIREMENTS OF THE CONTRACT MANUFACTURING SPEC. 27496/D15.
9. UNLESS OTHERWISE SPECIFIED ALL WELDS TO BE 6mm CONTINUOUS FILLETS OR FULL STRENGTH BUTT WELDS.
10. ALL PLATE JOINTS MADE FOR CONVENIENCE OF MANUFACTURE TO BE FULL STRENGTH BUTT WELDS. GROUND FLUSH, WITH 100% MPI & 100% UT.
11. DIMENSIONS OF DEVELOPED PLATES DO NOT INCLUDE ANY ADDITIONS FOR FABRICATION OR WELD PREPARATION.
12. NDT TO BE CARRIED OUT TO THE CONTRACT MANUFACTURING SPECIFICATION & THIS DRAWING.
13. MATERIAL CERTIFICATION IS REQUIRED IN ACCORDANCE WITH THE CONTRACT MANUFACTURING SPECIFICATION.
14. FOR PERMISSIBLE FABRICATION TOLERANCES, SEE THE CONTRACT MANUFACTURING SPECIFICATION.
15. MAXIMUM AXIAL RUN OUT OF WHEEL RIM EDGE 'X' (SEE SECTION KK, SHT 4) RELATIVE TO CENTRE LINE B/W TO BE 15mm TOTAL INDICATOR READING (CD - SEE NOTE 9).
16. MAXIMUM AXIAL RUN OUT OF OCTAGONAL FACE 'Y' (SEE SECTION KK, SHT 4) RELATIVE TO CENTRE LINE B/W TO BE 10mm TOTAL INDICATOR READING (CD - SEE NOTE 9).
17. MAXIMUM RADIAL RUN OUT OF WHEEL RIM (R3200) RELATIVE TO CENTRE LINE B/W TO BE 5mm TOTAL INDICATOR READING (CD - SEE NOTE 9).
18. DIMENSIONS MARKED 'CD' ARE CRITICAL DIMENSIONS & ARE TO BE RECORDED ON THE INSPECTION PLAN.
19. MACHINING TO BE CARRIED OUT AFTER COMPLETION OF ALL FABRICATION WORK.
20. PAINTING & PROTECTION TO MANUFACTURING SPECIFICATION 27496/D15.

DO NOT SCALE
 IF IN DOUBT - ASK

	SOUTH AFRICAN PORT OPERATIONS IRON ORE TERMINAL - SALDANHA STACKER RECLAIMER CONTRACT HQH375 SANCTION No SB01D1		
	DRAWN TO BS 8888 WELD SYMBOLS TO ANKANSI 2.4 SURFACE TEXTURE TO BS 1318, PROJ. MATERIAL & CONDITION BEFORE MANUFACTURE		THIRD ANGLE PROJ.
	MATERIAL		
	SPEC.		
GRADE			MASS
NOTES			ORIGINAL SCALE
			1:25
			16879kg
			SIZE
			A1
			DRAWING NUMBER
			700455
TITLE			SHEET OF ISSUE
SALDANHA BAY STACKER RECLAIMER ASSEMBLY & DETAILS OF BUCKETWHEEL STRUCTURE			1 5 D

UNLESS OTHERWISE SPECIFIED IDENTIFY THE ITEM WITH THE DRAWING NUMBER AND ISSUE LEVEL, AND IN THE MANNER SHOWN FOR PAINTING AND FOR LUBRICATION SPECIFICATIONS SEE COMPONENTS LIST.			
UNLESS OTHERWISE STATED DIMENSIONS ARE IN MILLIMETRES. TOLERANCES UNLESS OTHERWISE STATED (PLUS OR MINUS):			
RANGE	MACH	FAB	CAST
0-25	±0.15	±0.2	±0.3
25-50	±0.2	±0.3	±0.4
50-100	±0.3	±0.4	±0.5
100-200	±0.4	±0.5	±0.6
200-500	±0.5	±0.6	±0.7
500-1000	±0.7	±0.8	±1.0
1000-2000	±1.0	±1.2	±1.5
2000-5000	±1.5	±1.8	±2.0
5000-10000	±2.0	±2.5	±3.0
10000-20000	±3.0	±3.5	±4.5
20000-50000	±4.5	±5.5	±7.0
50000-100000	±7.0	±8.5	±11.0
100000-200000	±11.0	±13.5	±17.0
200000-500000	±17.0	±21.0	±27.0
500000-1000000	±27.0	±33.5	±43.0
1000000-2000000	±43.0	±53.5	±69.0
2000000-5000000	±69.0	±86.5	±111.0
5000000-10000000	±111.0	±138.5	±178.0
10000000-20000000	±178.0	±223.5	±288.0
20000000-50000000	±288.0	±361.5	±465.0
50000000-100000000	±465.0	±583.5	±753.0
100000000-200000000	±753.0	±946.5	±1224.0
200000000-500000000	±1224.0	±1546.5	±1998.0
500000000-1000000000	±1998.0	±2546.5	±3297.0
1000000000-2000000000	±3297.0	±4146.5	±5394.0

FIRST ISSUE									
DATE	DATE	DATE	DATE	DATE	DATE	DATE	DATE	DATE	DATE
CHECKED GMB	CHECKED JWH	CHECKED JWH	CHECKED DWB	CHECKED DWB	CHECKED CBL	CHECKED JWH	CHECKED JWH	CHECKED DWB	CHECKED JWH
25 FEB 2008	25 FEB 2008	25 FEB 2008	25 FEB 2008	25 FEB 2008	23/5/02	21 AUG 02	21 AUG 02	19 AUG 02	19/6/02
APPROVED	APPROVED	APPROVED	APPROVED	APPROVED	APPROVED	APPROVED	APPROVED	APPROVED	APPROVED
7 FEB 2008	25 FEB 2008	25 FEB 2008	25 FEB 2008	25 FEB 2008	23/5/02	21 AUG 02	21 AUG 02	19 AUG 02	19/6/02

ISSUES RAISED GEN.UPDATE AS BUILT			
DATE	DATE	DATE	DATE
CHECKED RD	CHECKED JWH	CHECKED DWB	CHECKED DWB
22.6.06	22.6.06	19 AUG 02	19/6/02
APPROVED	APPROVED	APPROVED	APPROVED
7 FEB 2008	25 FEB 2008	25 FEB 2008	25 FEB 2008

SEE SHEETS 4 & 5			
DATE	DATE	DATE	DATE
CHECKED GMB	CHECKED JWH	CHECKED DWB	CHECKED DWB
25 FEB 2008	25 FEB 2008	25 FEB 2008	25 FEB 2008
APPROVED	APPROVED	APPROVED	APPROVED
7 FEB 2008	25 FEB 2008	25 FEB 2008	25 FEB 2008

SEE SHEETS 3 & 4.			
DATE	DATE	DATE	DATE
CHECKED RD	CHECKED JWH	CHECKED DWB	CHECKED DWB
22.6.06	22.6.06	19 AUG 02	19/6/02
APPROVED	APPROVED	APPROVED	APPROVED
7 FEB 2008	25 FEB 2008	25 FEB 2008	25 FEB 2008

ISSUES RAISED GEN.UPDATE AS BUILT			
DATE	DATE	DATE	DATE
CHECKED RD	CHECKED JWH	CHECKED DWB	CHECKED DWB
22.6.06	22.6.06	19 AUG 02	19/6/02
APPROVED	APPROVED	APPROVED	APPROVED
7 FEB 2008	25 FEB 2008	25 FEB 2008	25 FEB 2008

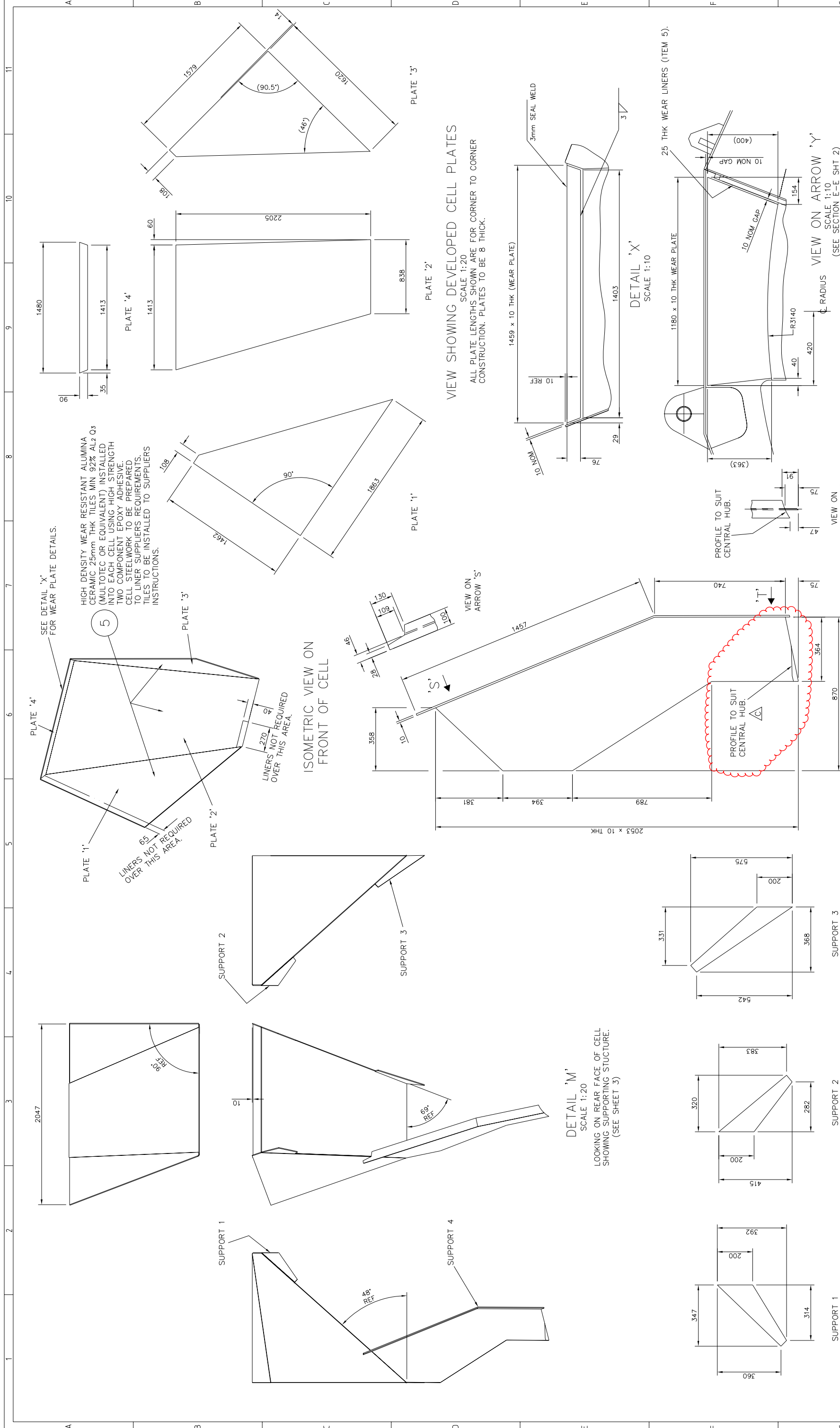

DO NOT SCALE
IF IN DOUBT - ASK

SOUTH AFRICAN PORT OPERATIONS
 IRON ORE TERMINAL - SALDANHA
 STACKER RECLAIMER CONTRACT HQH375
 SANCTION No. SB01D1

metso
minerals

TITLE
SALDANHA BAY STACKER RECLAIMER ASSEMBLY & DETAILS OF BUCKETWHEEL STRUCTURE

DRAWN TO BS 8888
 WELD SYMBOLS TO AWS A5.1
 SURFACE TEXTURE TO BS 1318
 MATERIAL & CONDITION BEFORE MANUFACTURE

SEE SHEET 1

MASS SHEET 1 1:10 UOS
 ORIGINAL SCALE
 DRAWING NUMBER 700455
 SHEET OF 5
 ISSUE D

UNLESS OTHERWISE SPECIFIED IDENTIFY THE ITEM WITH THE DRAWING NUMBER AND ISSUE LEVEL AND IN THE MANNER SHOWN FOR PAINTING AND FOR LUBRICATION SPECIFICATIONS SEE COMPONENTS LIST.	THIRD ANGLE
UNLESS OTHERWISE STATED DIMENSIONS ARE IN MILLIMETRES. TOLERANCES UNLESS OTHERWISE STATED (PLUS OR MINUS)	
RANGE	MACH FAB CAST
0-25	2
25-50	3
50-100	4
100-200	6
ABOVE 200	10

FIRST ISSUE	
DRAWN	CHECKED
CBL	DWB
DATE	DATE
23/5/02	19/6/02
APPROVED	JWH
DATE	DATE
21 AUG 02	21/6/02

SEE SHEETS 3 & 4.	
DRAWN	CHECKED
JWH	DWB
DATE	DATE
19 AUG 02	19/6/06
APPROVED	JWH
DATE	DATE
21 AUG 02	22.6.06

ISSUES RAISED GEN.UPDATE AS BUILT	
DRAWN	CHECKED
DDB	RD
DATE	DATE
19.04.06	22.6.06
APPROVED	JWH
DATE	DATE
25 FEB 2008	25 FEB 2008

SUPPORT 4 PROFILE CHANGED SEE SHEET 4	
DRAWN	CHECKED
PCB	GMB
DATE	DATE
7 FEB 2008	25 FEB 2008
APPROVED	DATE
DATE	DATE
DATE	DATE

SUPPORT 3	
DRAWN	CHECKED
DATE	DATE
DATE	DATE
DATE	DATE

SUPPORT 2	
DRAWN	CHECKED
DATE	DATE
DATE	DATE
DATE	DATE

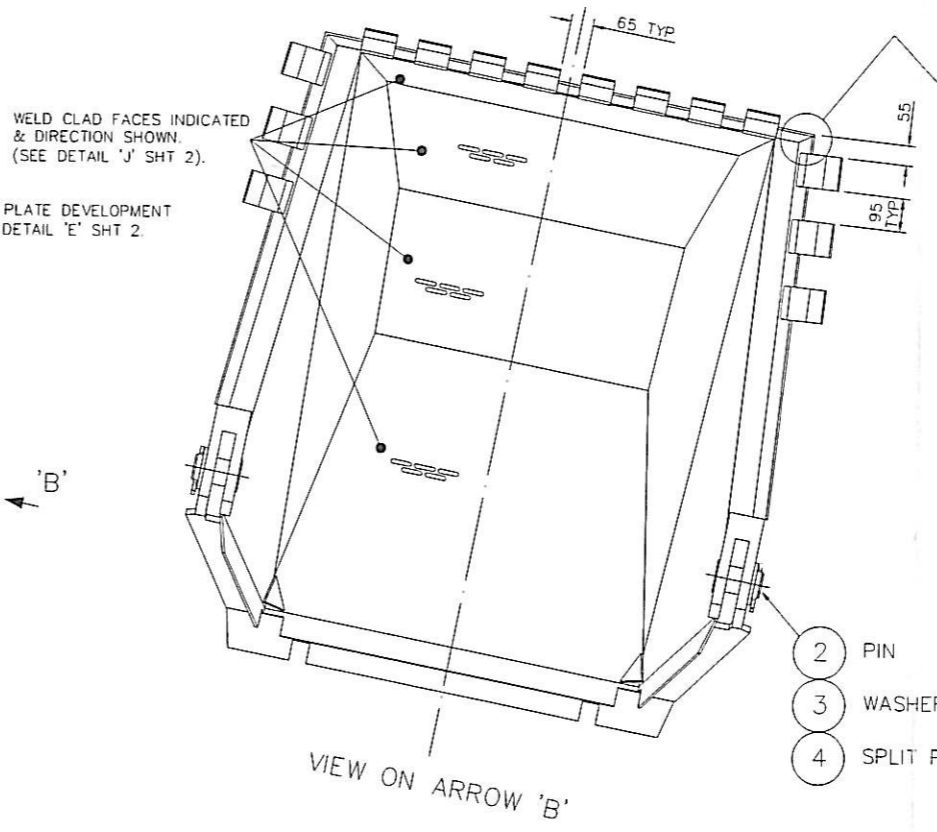
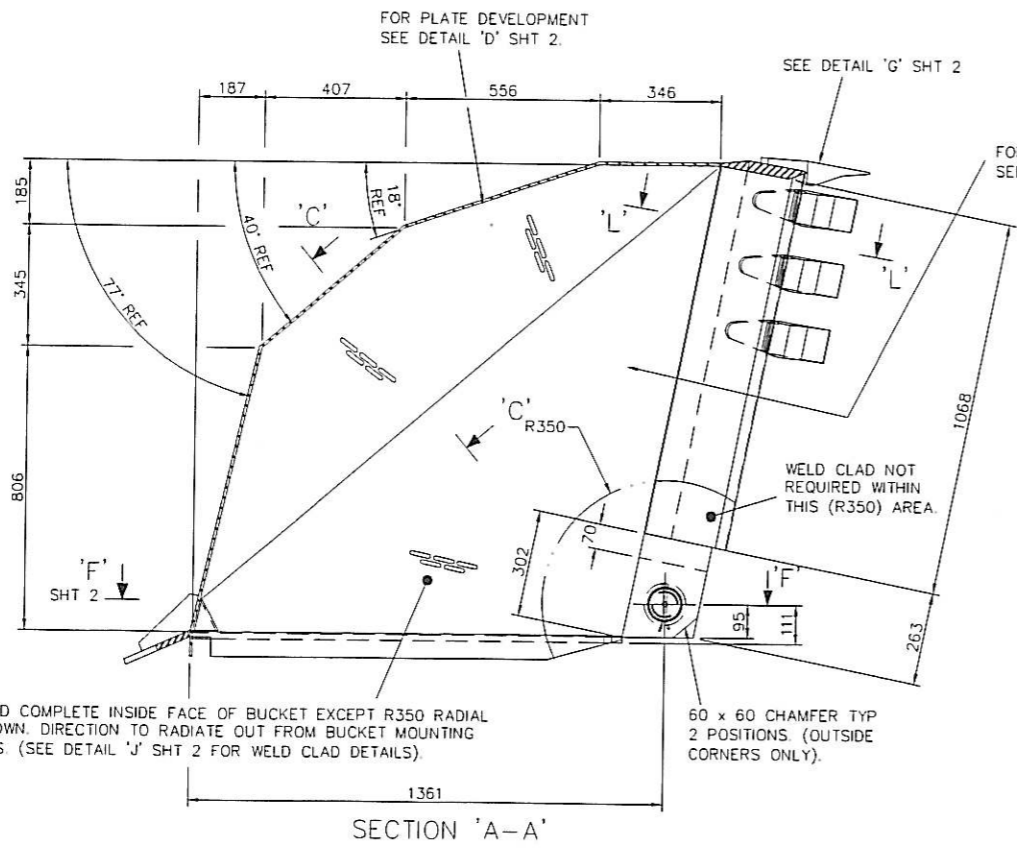
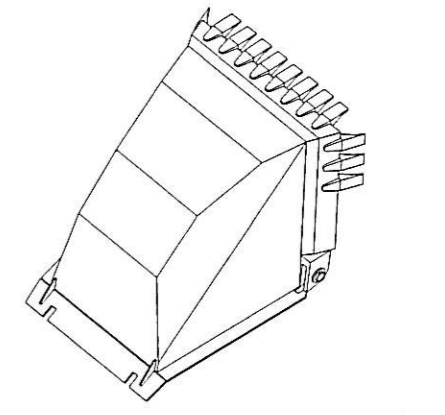
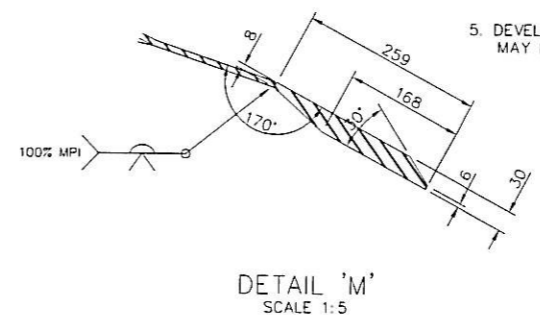
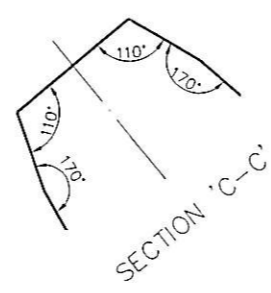
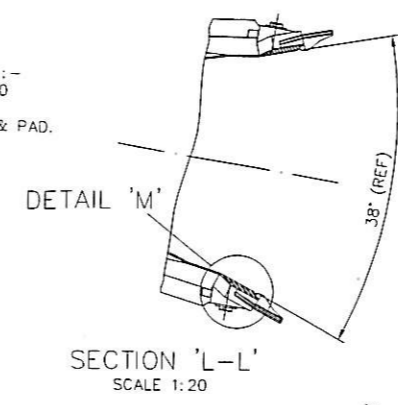
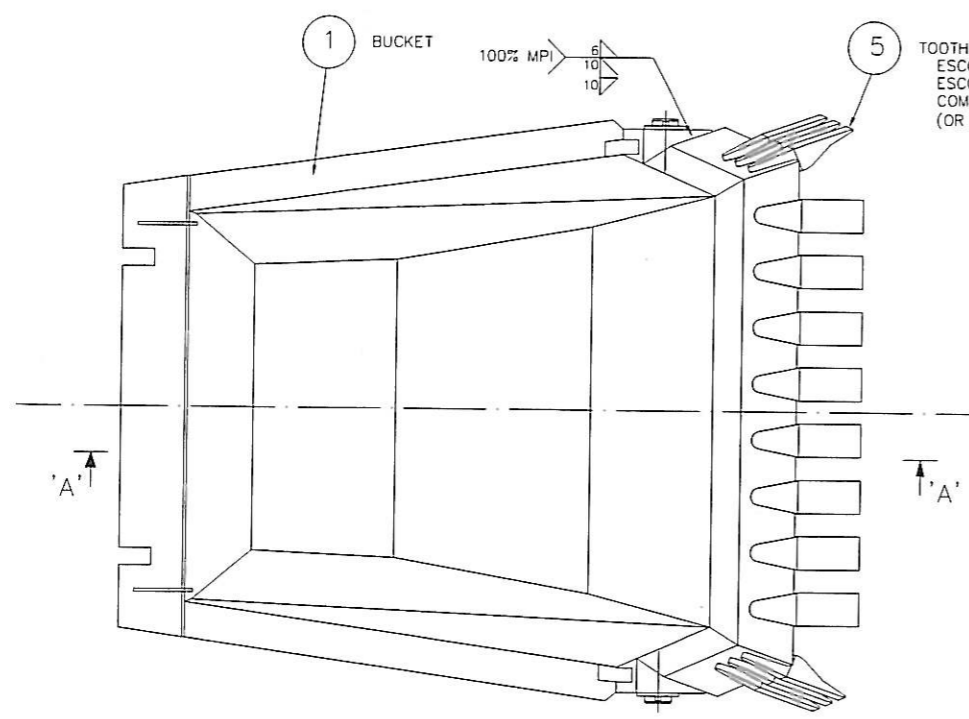

- 2 PIN
- 3 WASHER
- 4 SPLIT PIN $\phi 10 \times 112$ LG

NOTES:
 THIS DRAWING TO BE READ IN CONJUNCTION WITH :-
 700455, ASSEMBLY & DETAILS OF BUCKETWHEEL STRUCTURE
 (SHOP TRIAL ASSEMBLE ALL BUCKETS TO WHEEL STRUCTURE & MATCH MARK)
 27496/D15, MANUFACTURING SPECIFICATION.

1. MAIN BODY OF BUCKET FABRICATED FROM 8 THK PLATE TO XAR 15 (OR EQUIVALENT) & MAY BE OF WELDED OR FOLDED CONSTRUCTION.
2. 30 THK LIP TO XAR 15 (OR EQUIVALENT).
3. ALL OTHER PLATE FROM SABS 1431, 350WA.
4. MANUFACTURE TO FULLY CONFORM TO THE REQUIREMENTS OF THE CONTRACT MANUFACTURING SPEC DOC 27496 / D15. ALL WELDS UNLESS OTHERWISE SPECIFIED TO BE FULL STRENGTH BUTT WELDS WITH SEALING WELDS FROM OTHER SIDE TO ENSURE NO CAVITIES ARE LEFT. WELD PROCEDURES (INCLUDING PRE HEAT & DETAILS OF CONSUMABLES) FOR XAR 15 PLATE TO BE SUPPLIED TO METSO FOR APPROVAL PRIOR TO MANUFACTURE. WELD CLAD COMPLETE INSIDE FACES OF MAIN BODY & LIP OF BUCKET (INCLUDING TRIANGULAR CORNER PIECES) EXCEPT WHERE NOTED.
5. DEVELOPED PLATE DIMENSIONS ARE FOR 'CORNER TO CORNER' CONSTRUCTION, AND MAY NEED TO BE ADJUSTED BY MANUFACTURER TO SUIT FABRICATION PROCESS.

WELD CLAD COMPLETE INSIDE FACE OF BUCKET EXCEPT R350 RADIAL AREA SHOWN. DIRECTION TO RADIATE OUT FROM BUCKET MOUNTING PIN HOLES. (SEE DETAIL 'J' SHT 2 FOR WELD CLAD DETAILS)

WELD CLAD NOT REQUIRED WITHIN THIS (R350) AREA.

60 x 60 CHAMFER TYP 2 POSITIONS (OUTSIDE CORNERS ONLY).

1800 LITRE BUCKET CAPACITY

DO NOT SCALE IF IN DOUBT - ASK		SOUTH AFRICAN PORT OPERATIONS IRON ORE TERMINAL - SALDANHA STACKER RECLAIMER CONTRACT HQH375 SANCTION No SB01 D1	
DRAWN TO BS 8888 WELD SYMBOLS TO BS EN 22553 SURFACE TEXTURE TO BS 1134 MATERIAL & CONDITION BEFORE MANUFACTURE			
MATERIAL & CONDITION BEFORE MANUFACTURE		METSO MINERALS (UK Ltd) BULK MATERIALS HANDLING BRISTOL PO BOX 821 ASHTON VALE RD BRISTOL BS99 5ZB ENGLAND.	
SPEC.		TITLE SALDANHA BAY STACKER RECLAIMER ASSEMBLY & DETAILS OF BUCKET	
GRADE		SIZE A1	
NOTES		DRAWING NUMBER 700456	
MASS 790kg		ORIGINAL SCALE 1:10 UOS	
DATE		SHEET OF ISSUE 1 2 B	

ISSUES RAISED GEN.UPDATE AS BUILT			FIRST ISSUE		
UNLESS OTHERWISE SPECIFIED IDENTIFY THE ITEM WITH THE DRAWING NUMBER AND ISSUE LEVEL AT ϕ AND IN THE MANNER SHOWN FOR PAINTING AND FOR LUBRICATION SPECIFICATIONS SEE COMPONENTS LIST	UNLESS OTHERWISE STATED DIMENSIONS ARE IN MILLIMETRES TOLERANCES UNLESS OTHERWISE STATED (PLUS OR MINUS)				
	RANGE	MACH	FAB	CAST	
	0-500	0.25	2	2	
	501-1000	0.5	3	4	
	1001-2000	1.0	4	6	
	ABOVE 2000	2.0	6	10	
This print and all the information hereon is the property of Metso Minerals. Bulk Materials Handling Bristol and must not be made public, copied or used in any way detrimental to our interest. It is loaned subject to return on demand, unless furnished under contract provisions.					
DRAWN	CHECKED	APPROVED	DRAWN	CHECKED	APPROVED
DATE	DATE	DATE	DATE	DATE	DATE
			19 04 06	22 6 06	22 6 06
			MAY 02	JUNE 02	JUNE 02

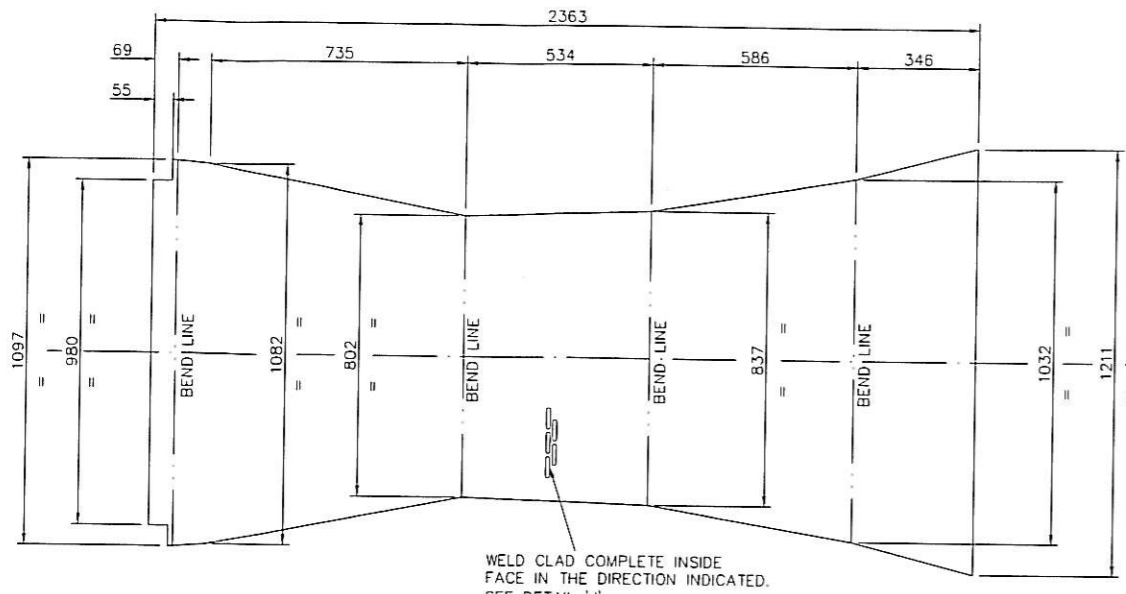

DETAIL 'D'
(DEVELOPMENT OF TOP/BACK PANELS)

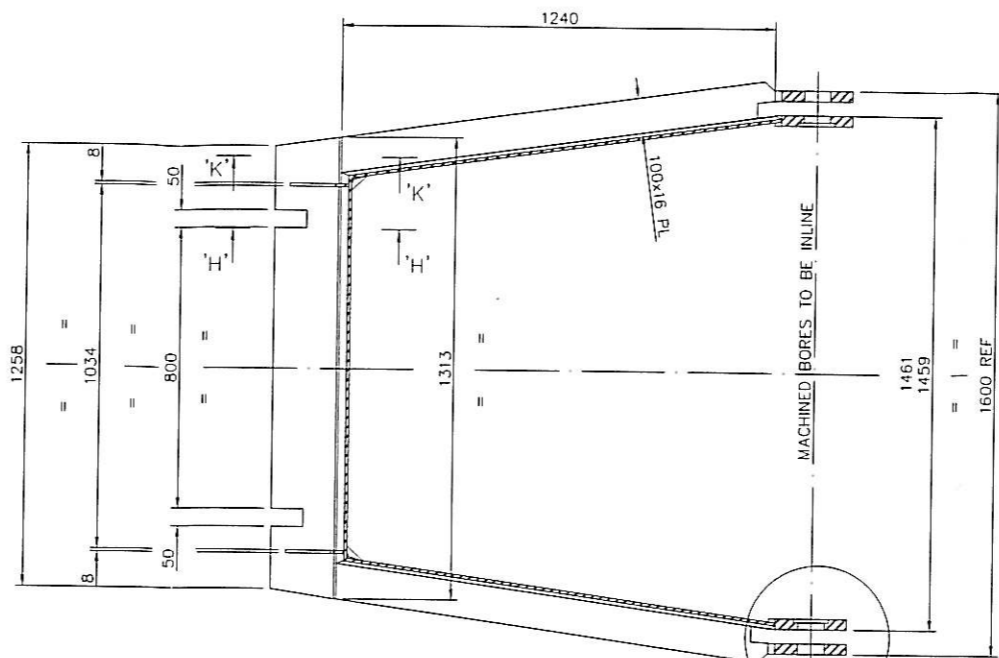

SECTION 'F-F'
(SHEET 1)

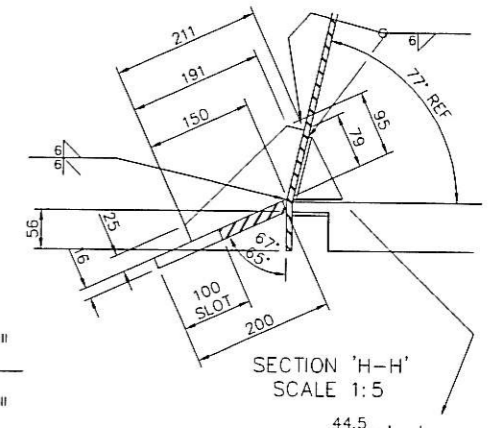

SECTION 'H-H'
SCALE 1:5

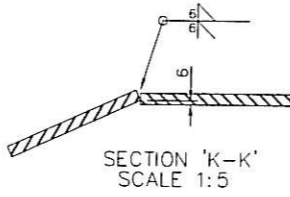
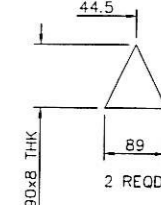

SECTION 'K-K'
SCALE 1:5

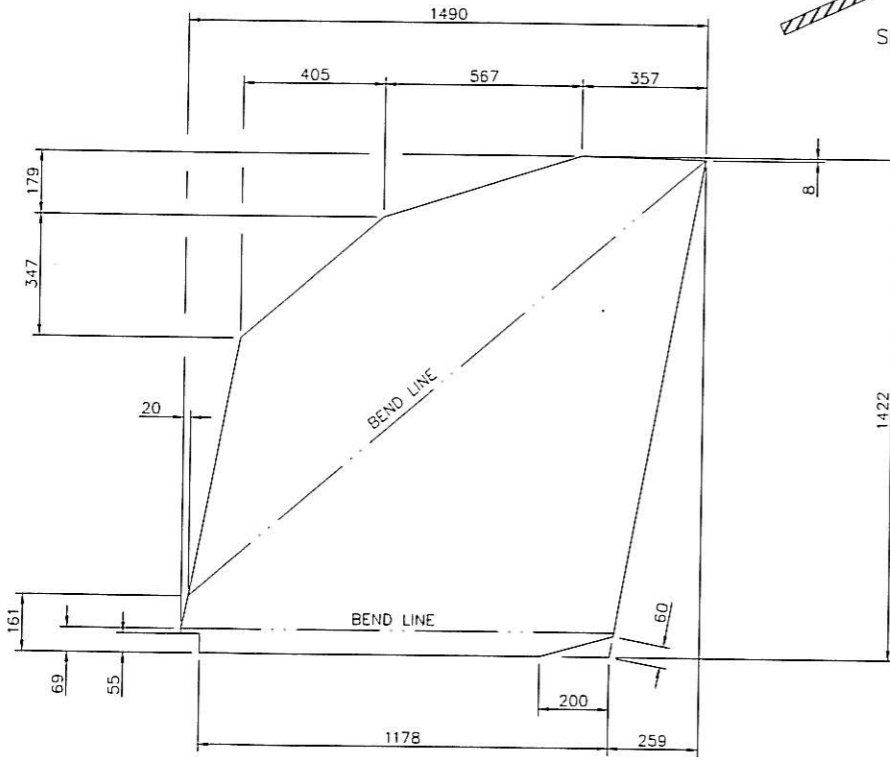

DETAIL 'E'
(SHEET 1)

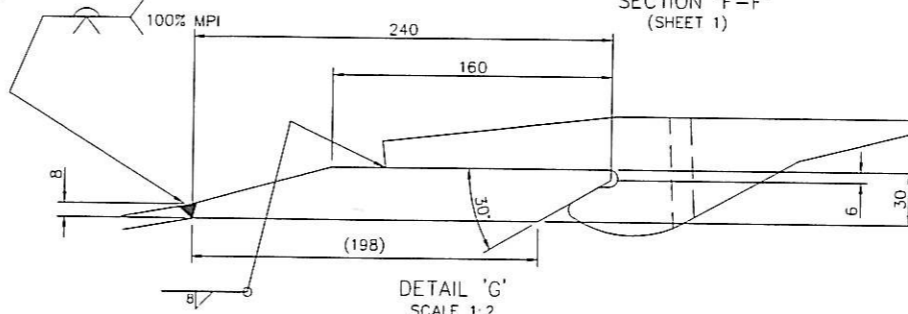

DETAIL 'G'
SCALE 1:2

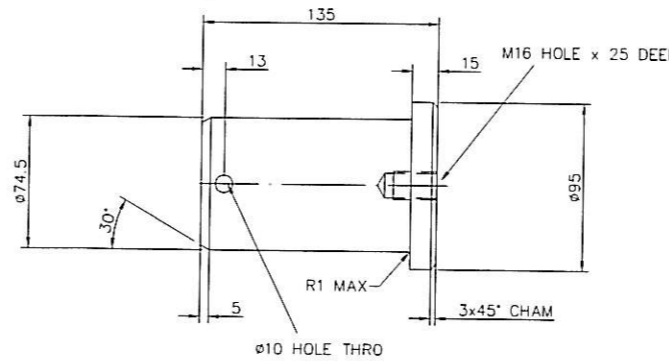
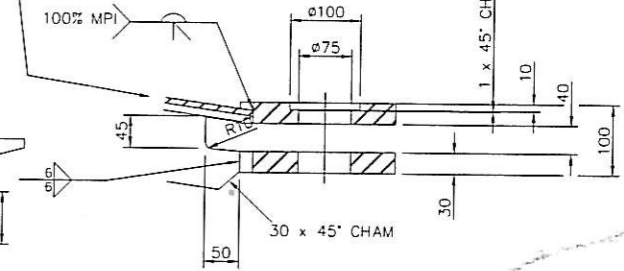

2 PIN
SCALE 1:2

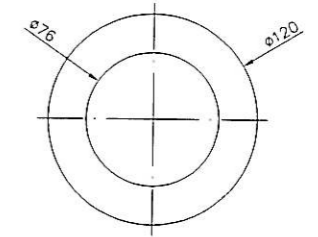

3 WASHER
SCALE 1:2

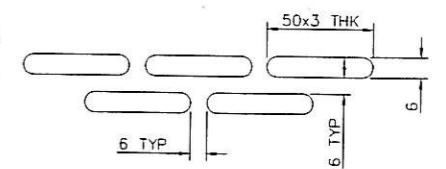

DETAIL 'J'
WELD CLAD AREAS SPECIFIED
MIN. 400 BHN.

DRAWN			CHECKED			APPROVED			DRAWN			CHECKED			APPROVED			DRAWN			CHECKED			APPROVED			DRAWN			CHECKED			APPROVED			DRAWN			CHECKED			APPROVED		
DATE			DATE			DATE			DATE			DATE			DATE			DATE			DATE			DATE			DATE			DATE			DATE			DATE			DATE			DATE		
1			2			3			4			5			6			7			8			9			10			11			12			13			14			15		

DO NOT SCALE
IF IN DOUBT - ASK

SOUTH AFRICAN PORT OPERATIONS
IRON ORE TERMINAL - SALDANHA
STACKER RECLAIMER CONTRACT HQH375
SANCTION No SB01 D1

metso minerals
METSO MINERALS (UK) LTD
BULK MATERIALS HANDLING BRISTOL
PO BOX 821 ASHTON VALE RD
BRISTOL BS99 5ZB ENGLAND

TITLE
SALDANHA BAY STACKER RECLAIMER
ASSEMBLY & DETAILS OF BUCKET

DRAWN TO BS 8888		WELD SYMBOLS TO BS EN 22553		THIRD ANGLE PROJ	
UNLESS OTHERWISE SPECIFIED IDENTIFY THE ITEM WITH THE DRAWING NUMBER AND ISSUE LEVEL AT 4 AND IN THE MANNER SHOWN FOR PAINTING AND FOR LUBRICATION SPECIFICATIONS SEE COMPONENTS LIST.		MATERIAL & CONDITION BEFORE MANUFACTURE			
UNLESS OTHERWISE STATED DIMENSIONS ARE IN MILLIMETRES TOLERANCES UNLESS OTHERWISE STATED (PLUS OR MINUS)					
RANGE	MACH	FAB	CAS		
0-500	0.25	2	2		
501-1000	0.5	3	4		
1001-2000	1.0	4	6		
ABOVE 2000	2.0	6	10		

MATERIAL & CONDITION BEFORE MANUFACTURE

THIS PRINT AND ALL THE INFORMATION HEREON IS THE PROPERTY OF METSO MINERALS. BULK MATERIALS HANDLING BRISTOL AND MUST NOT BE MADE PUBLIC, COPIED OR USED IN ANY WAY DETRIMENTAL TO OUR INTEREST. IT IS LOANED SUBJECT TO RETURN ON DEMAND, UNLESS FURNISHED UNDER CONTRACT PROVISIONS.

MASS	790kg	ORIGINAL SCALE	1:10 UCS	SIZE	A1	DRAWING NUMBER	700456	SHEET	2	OF	2	ISSUE	B
------	-------	----------------	----------	------	----	----------------	--------	-------	---	----	---	-------	---

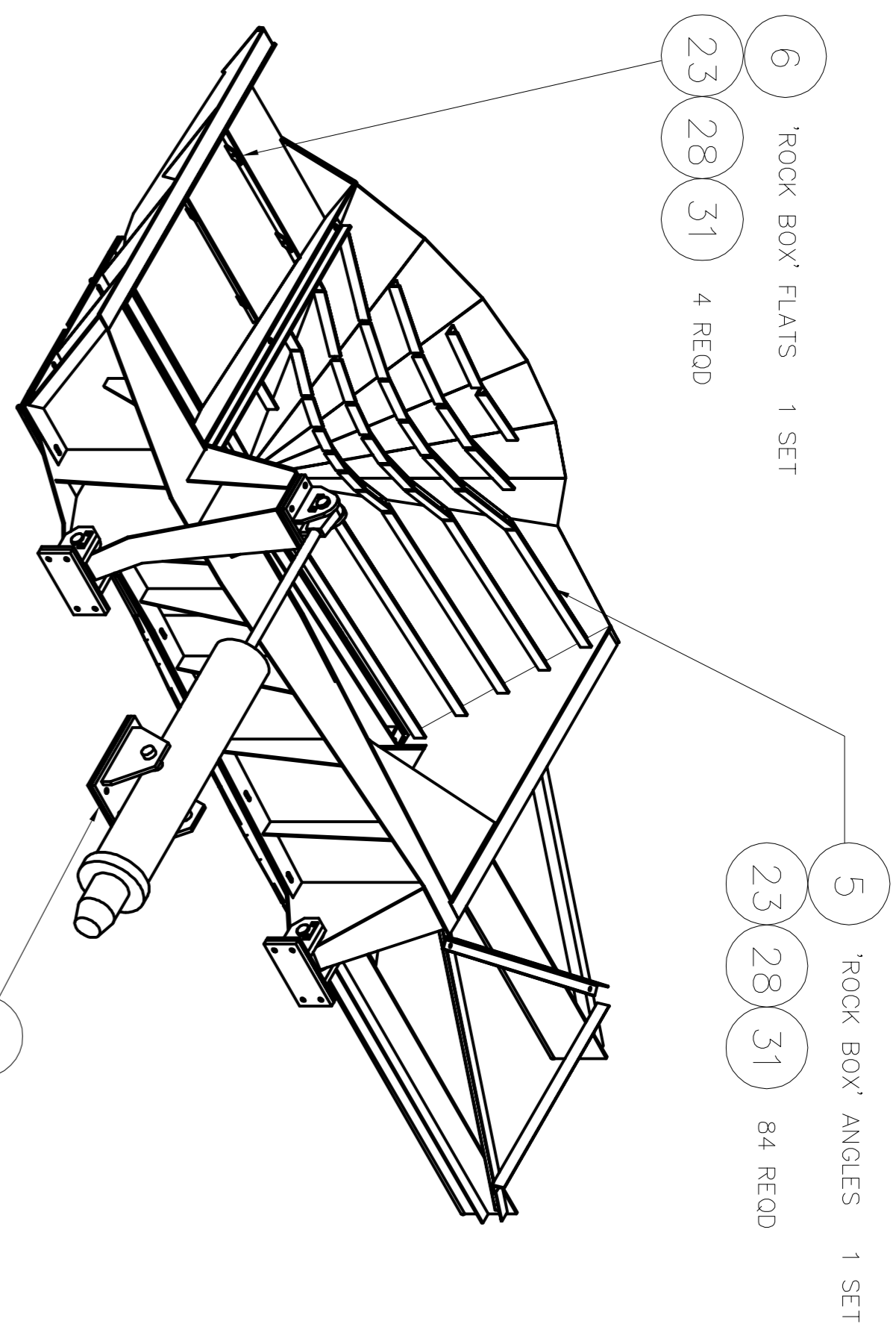

UPPER FRONT ISOMETRIC VIEW

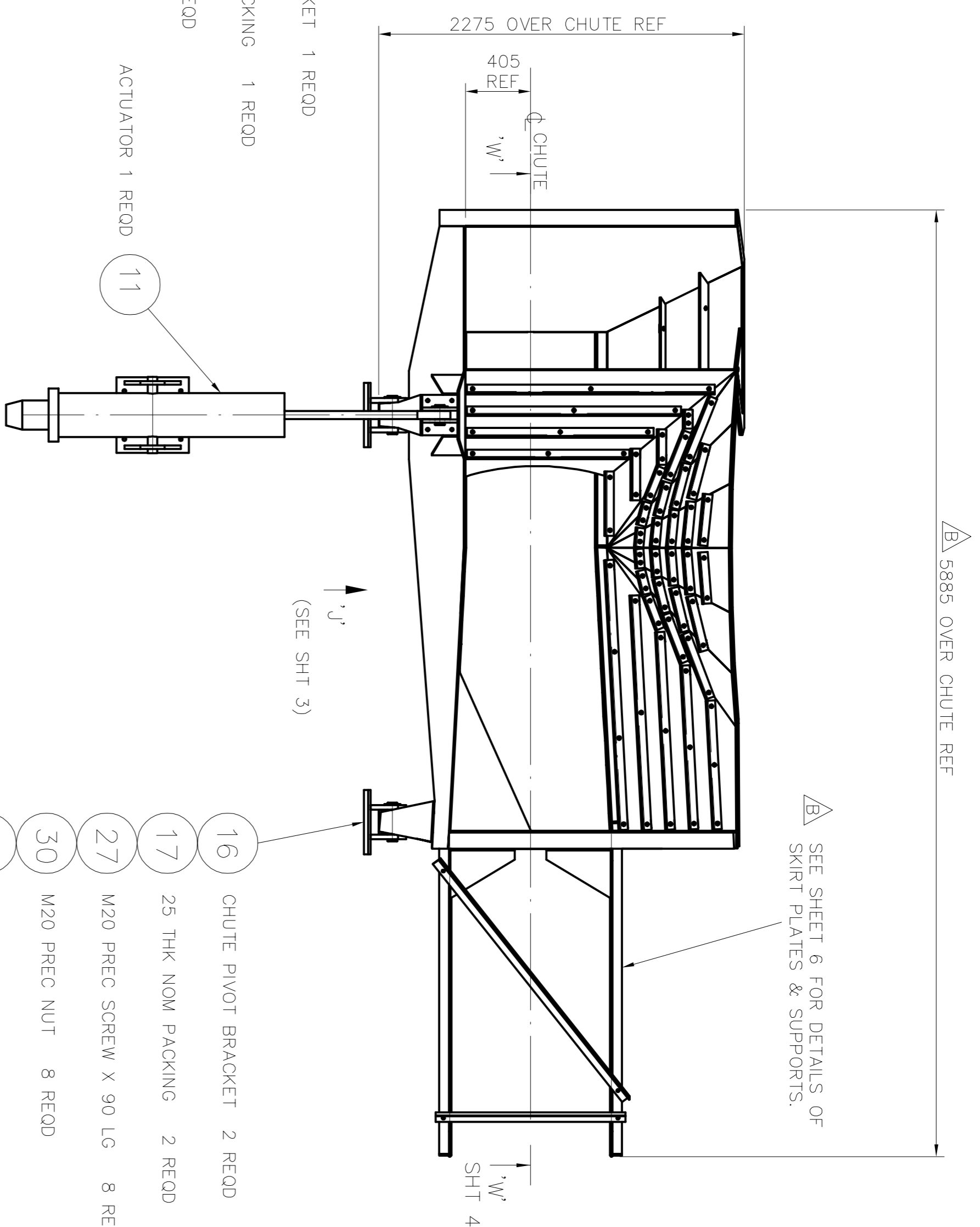

ACTUATOR 1 REOD

(SEE SHT 3)

SHT 4

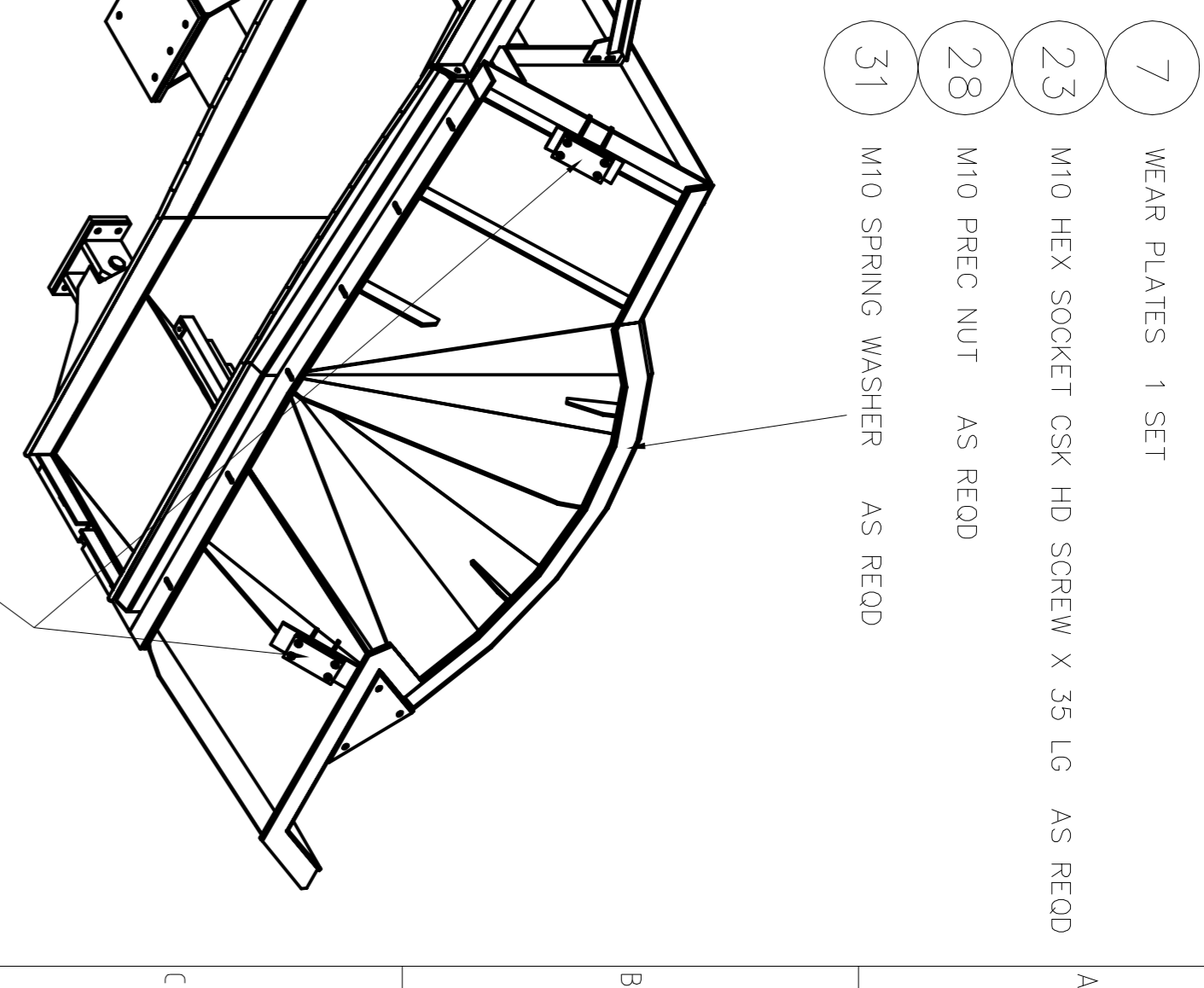

- 3 CLEVIS BRACKET 1 REOD
- 9 20 THK NOM PACKING 1 REOD
- 27 M20 PREC SCREW X 90 LG 4 REOD
- 30 M20 PREC NUT 4 REOD
- 33 M20 SPRING WASHER 4 REOD
- 4 PIN 1 REOD
- 10 KEEP PLATE 1 REOD
- 25 M12 PREC SCREW X 25 LG 2 REOD
- 32 M12 SPRING WASHER 2 REOD

- 16 CHUTE PIVOT BRACKET 2 REOD
- 17 25 THK NOM PACKING 2 REOD
- 27 M20 PREC SCREW X 90 LG 8 REOD
- 30 M20 PREC NUT 8 REOD
- 33 M20 SPRING WASHER 8 REOD
- 18 PACKER 2 REOD
- 19 16 THK NOM PACKING 2 REOD
- 24 M12 HEX SOCKET CSK HD SCREW X 70 LG 8 REOD
- 29 M12 PREC NUT 8 REOD
- 32 M12 SPRING WASHER 8 REOD

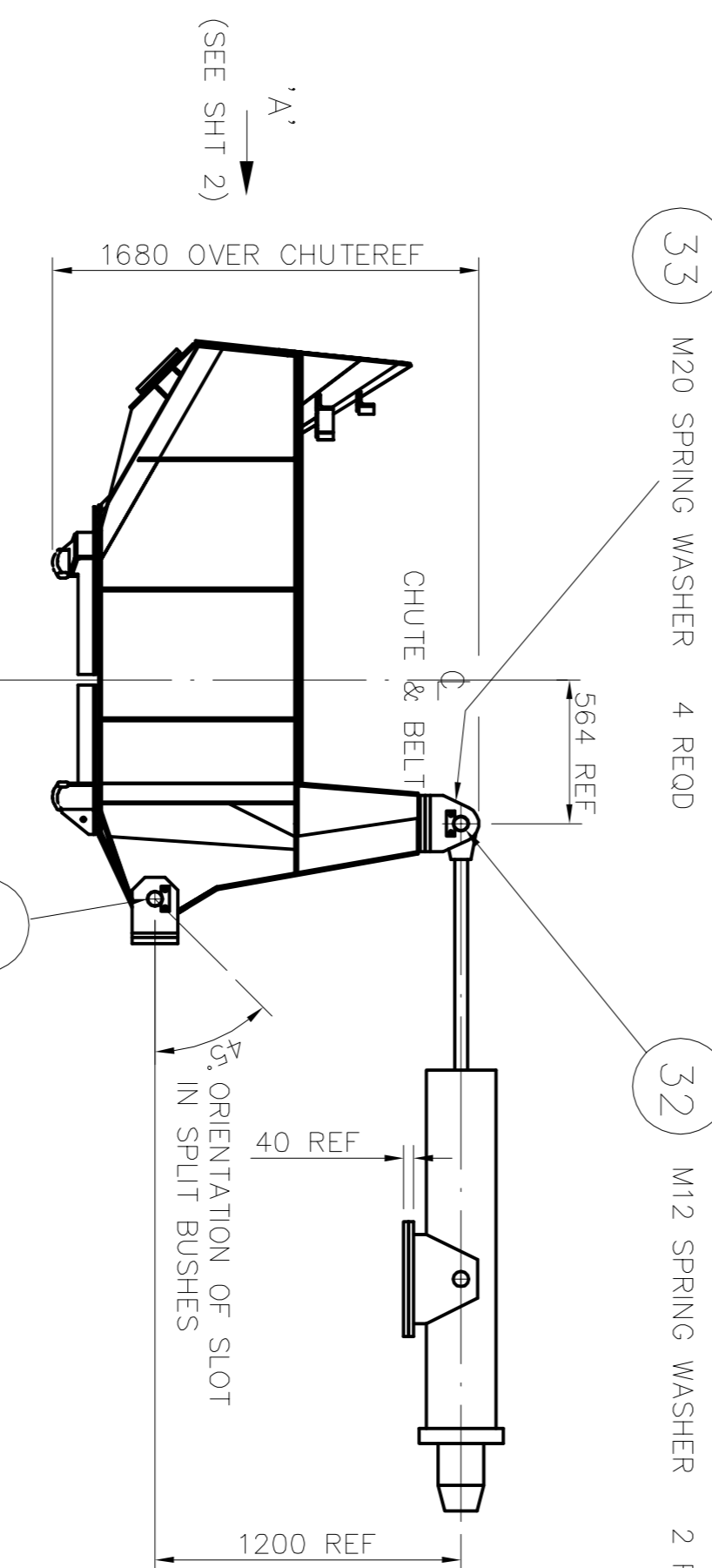

- 12 SPLIT BUSH 4 REOD
- 15 PIN 2 REOD
- 10 KEEP PLATE 2 REOD
- 25 M12 PREC SCREW X 25 LG 4 REOD
- 32 M12 SPRING WASHER 4 REOD

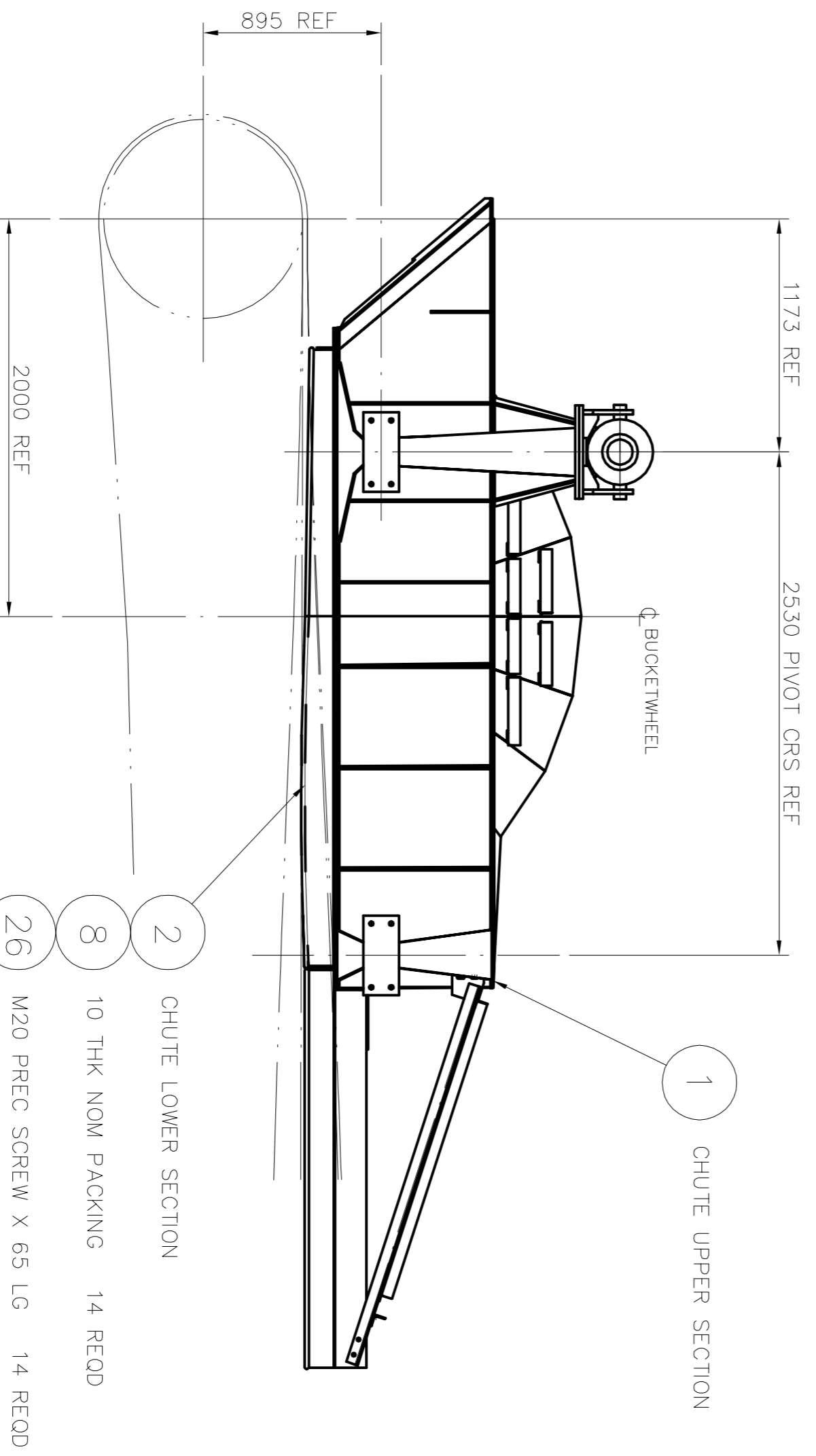

- 8 10 THK NOM PACKING 14 REOD
- 26 M20 PREC SCREW X 65 LG 14 REOD
- 30 M20 PREC NUT 14 REOD
- 33 M20 SPRING WASHER 14 REOD

NOTES :-

THIS DRAWING TO BE READ IN CONJUNCTION WITH :-

A) DOCUMENT 27496/D15, MANUFACTURING SPECIFICATION.

- MATERIAL: PLATES, FLATS, BARS & OPEN ROLLED SECTIONS TO SABS1431 GRADE 300WA (UOS ON COMPS LIST), WEAR & SKIRT PLATES TO BE VERN 500. GENERAL PLATE THICKNESS 10mm UOS.
- CERTIFICATION: CHEMICAL & MECHANICAL TEST CERTIFICATES REQUIRED FOR ALL MATERIALS IN ACCORDANCE WITH MANUFACTURING SPECIFICATION.
- WELDING: ALL WELDING TO BE CARRIED OUT IN ACCORDANCE WITH THE MANUFACTURING SPECIFICATION. ALL WELDS ARE TO BE 6mm CONTINUOUS FILETS UNLESS OTHERWISE SPECIFIED.
- SURFACE TREATMENT: TO CONFORM TO MANUFACTURING SPECIFICATION.
- FOR INSTALLATION & SET UP WITH BUCKETWHEEL & CONVEYOR, REFER TO ERECTION & COMMISSIONING SCHEDULES.
- OUTSTANDING ITEMS :- MAINTENANCE LUGS RAISE / LOWER LIMIT SWITCH BRACKETS

TOTAL MASS OF CHUTE STEELWORK 2200 KG

**DO NOT SCALE
IF IN DOUBT - ASK**



SOUTH AFRICAN PORT OPERATIONS
IRON ORE TERMINAL - SALDANHA
STACKER RECLAIMER CONTRACT H0H375
SANCTION NO. 580101

METSO MINERALS (UK) LTD
BULK MATERIALS HANDLING BRISTOL
PO BOX 82 ASHTON VALE RD
BRISTOL BS99 5ZB ENGLAND

SALDANHA BAY STACKER RECLAIMER
ASSEMBLY & DETAILS OF
BUCKETWHEEL CHUTE

DATE	APPROVED	DATE	APPROVED	DATE	APPROVED	DATE	APPROVED	DATE	APPROVED	DATE	APPROVED	DATE	APPROVED
DATE	DATE	DATE	DATE	DATE	DATE	DATE	DATE	DATE	DATE	DATE	DATE	DATE	DATE
1	2	3	4	5	6	7	8	9	10	11			

ISSUES RAISED GEN. UPDATE.
ADD SHEETS 7 & 8
MOD TO CONTROL SPILLAGE
BETWEEN CHUTE & BUCKET
WHEEL
AS BUILT

SKIRT PLATES & SUPPORTS
ADDED TO FRONT OF CHUTE
SEE LOC BY ADDITIONAL
STEELWORK ADDED TO
SUPPORT SKIRT PLATES
VIEW AT ON SHEET 2.
VIEW OF CYMBERS MODIFIED SEE
SHEET 6 ADDED.

FIRST ISSUE

UNLESS OTHERWISE SPECIFIED IDENTIFY THE ITEM WITH THE
DRAWING NUMBER AND ISSUE LEVEL AT AND IN THE MAINER SEE
SHOW FOR PAINTING AND FOR LUBRICATION SPECIFICATIONS
(CONCRETE'S LIST)

UNLESS OTHERWISE STATED DIMENSIONS ARE IN MILLIMETRES
TOLERANCES UNLESS OTHERWISE STATED (PLUS OR MINUS)

RANGE	MACH	FAB	CAST
0-500	0.25	2	2
501-1000	0.5	3	4
1001-2000	1.0	4	10
ABOVE 2000	2.0	6	10

This print and all the information hereon is the property of Metso Minerals. Bulk Materials Handling Bristol and must not be made public, copied or used in any way without the prior written consent of Metso Minerals. For return on demand, unless furnished under contract provisions.

DRAWN TO BS 8888
WELD SYMBOLS TO BS EN 22553
SURFACE TEXTURE TO BS 7552 (PRO)
MATERIAL & CONDITION BEFORE MANUFACTURE

MASS 2692kg
ORIGINAL SCALE 1:25
SIZE DRAWING NUMBER A1 700457
SHEET OF 1
ISSUE 8
C

7 WEAR PLATE FLATS 100x10 THK (1 SET) TO FOLLOW FULL LENGTH OF TOP EDGE OF CHUTE. THIS SIDE ONLY.
 LENGTH OF INDIVIDUAL WEAR PLATES TO BE DETERMINED BY FABRICATOR.
 FIXING HOLES Ø11 THRO & CSK Ø24 x 90. NUMBER OF FIXINGS TO SUIT LENGTHS OF WEAR PLATES.
 FULL LENGTH BACKING FLATS 100 x 10 THK REQUIRED WELDED IN POSITION TO SUIT.

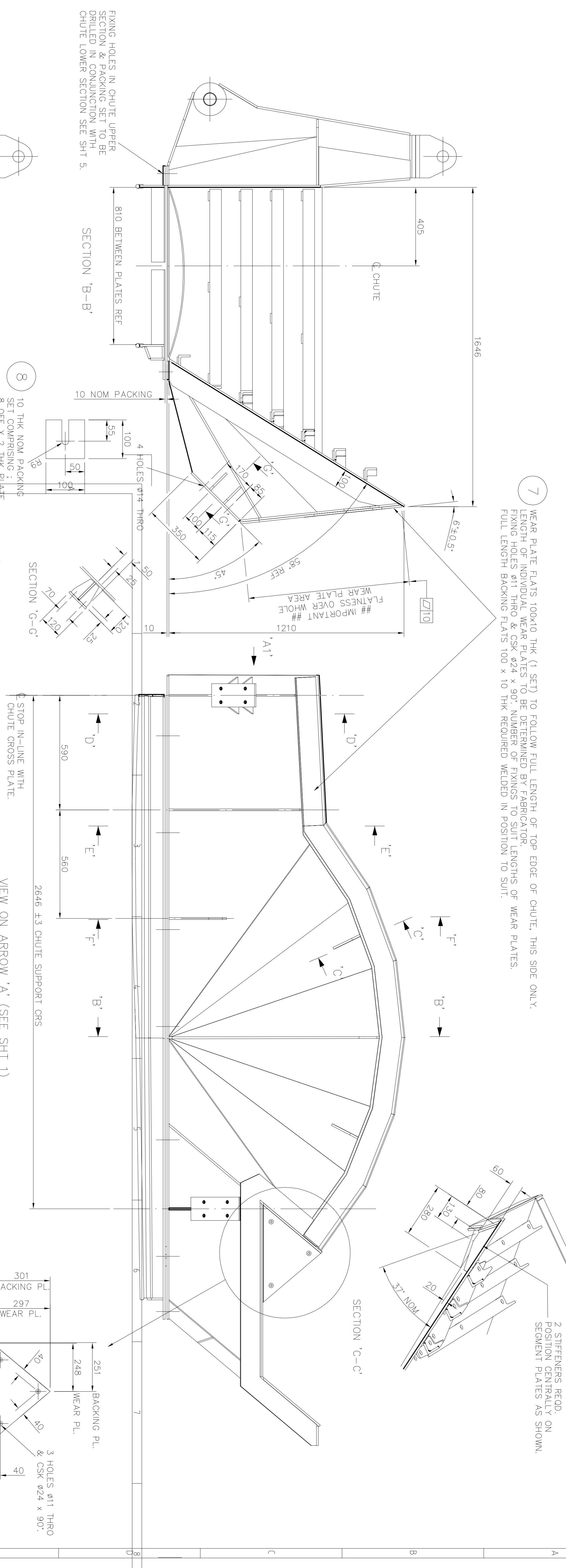
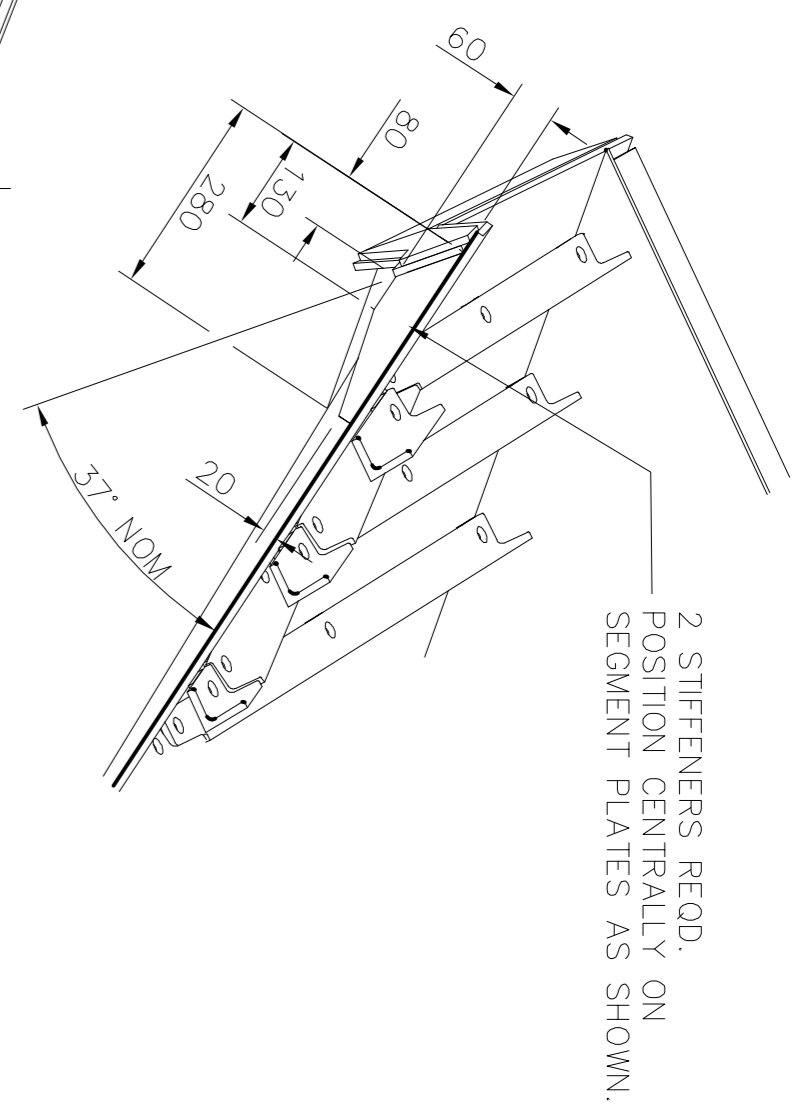

VIEW ON ARROW 'A' (SEE SHT 1)
 (VIEW ON REAR FACE OF CHUTE)

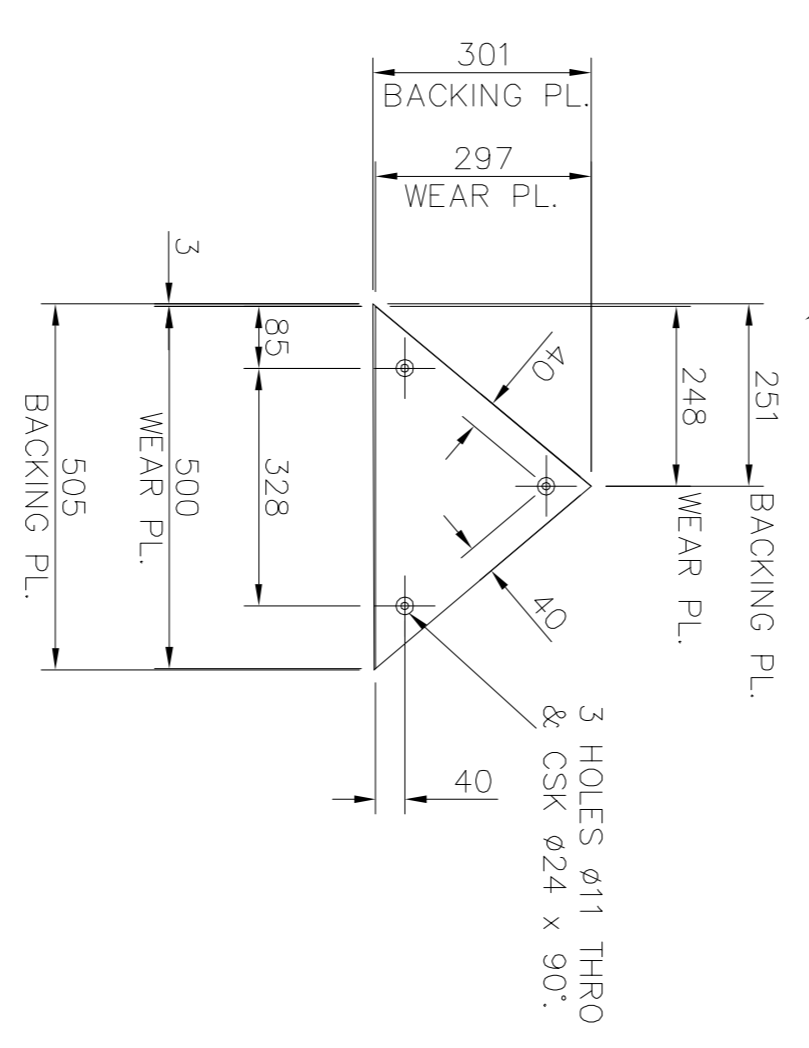

WEAR PLATE
 PART ITEM 7

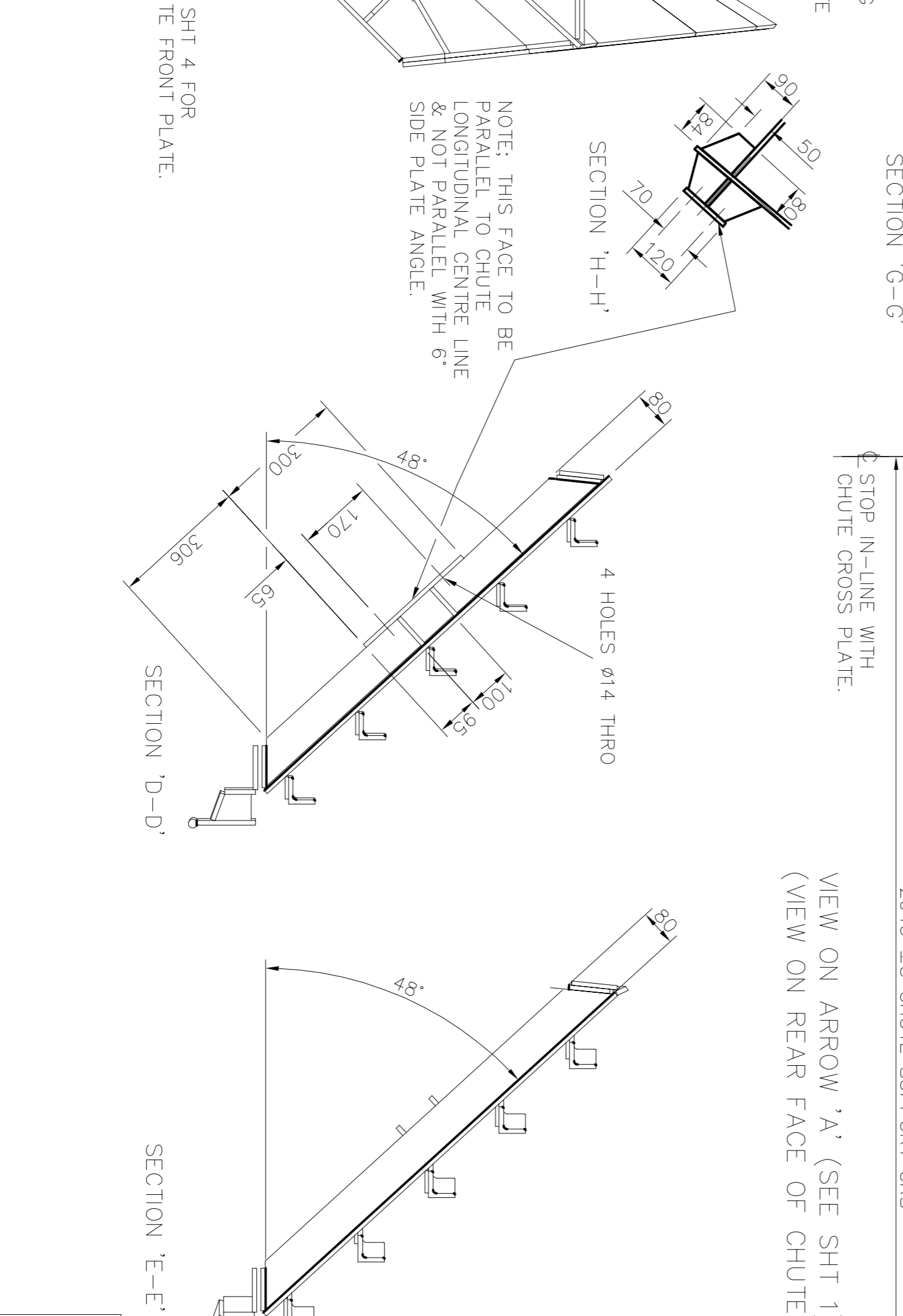
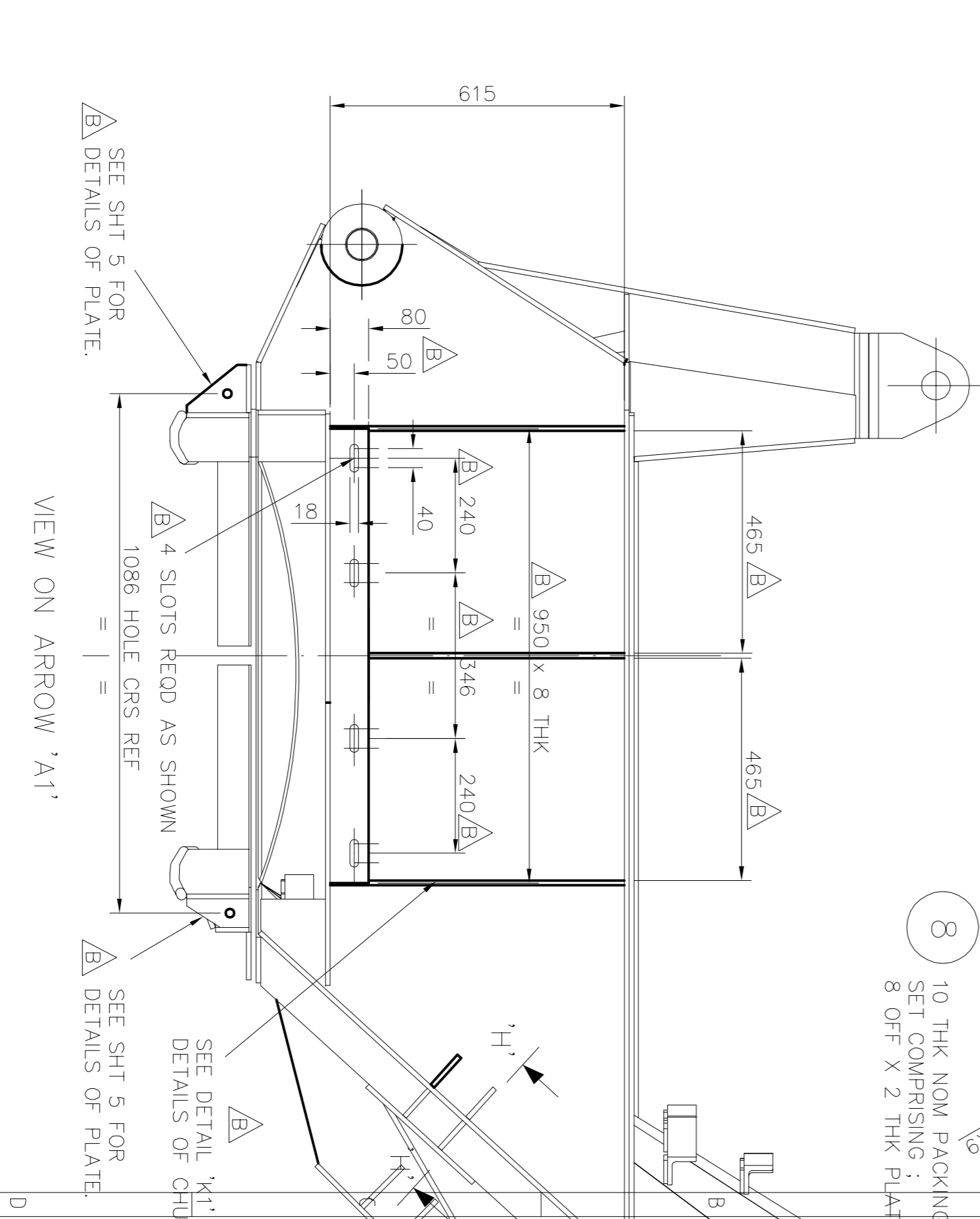

DO NOT SCALE
 IF IN DOUBT - ASK

metso minerals

SOUTH AFRICAN PORT OPERATIONS
 IRON ORE TERMINAL - SALDANHA
 STACKER RECLAIMER CONTRACT HOH375
 SANCTION No. SB011D1

metso minerals (UK) Ltd
 BULK MATERIALS HANDLING BRISTOL
 PO BOX 821 ASHTON VALE RD
 BRISTOL, BS99 5ZB ENGL AND.

TITLE
 SALDANHA BAY STACKER RECLAIMER
 ASSEMBLY & DETAILS OF
 BUCKETWHEEL CHUTE

MASS kg ORIGINAL SCALE 1:10 SIZE DRAWING NUMBER 700457 SHEET OF ISSUE 2 8 C

ISSUES RAISED GEN. UPDATE
 ADD SHEETS 7 & 8.
 MOD TO CONTROL SPILLAGE
 BETWEEN CHUTE & BUCKET
 WHEEL
 AS BUILT

VIEW ON ARROW 'A1' MODIFIED

FIRST ISSUE

UNLESS OTHERWISE SPECIFIED IDENTIFY THE ITEM WITH THE DRAWING NUMBER AND ISSUE LEVEL. AT AND IN THE MANNER SHOWN FOR PAINTING AND FOR LUBRICATION SPECIFICATIONS. SEE COMPONENTS LIST.
 UNLESS OTHERWISE STATED DIMENSIONS ARE IN MILLIMETRES.
 TOLERANCES UNLESS OTHERWISE STATED ARE (IN MM/INCH):
 0-500 0.25 3 4
 501-1000 0.5 3 4
 1001-2000 1.0 4 6
 ABOVE 2000 2.0 6 10

This print and all the information hereon is the property of Metso Minerals. Bulk Materials Handling Bristol and must not be made public, copied or used in any way detrimental to our interest. It is loaned subject to return on demand unless furnished under contract provisions.

DATE	APPROVED	DATE	APPROVED	DATE	APPROVED	DATE	APPROVED	DATE	APPROVED	DATE	APPROVED
DATE	DATE	DATE	DATE	DATE	DATE	DATE	DATE	DATE	DATE	DATE	DATE
DRAWN	CHECKED	DRAWN	CHECKED	DRAWN	CHECKED	DRAWN	CHECKED	DRAWN	CHECKED	DRAWN	CHECKED
DB	DDB	RD	JWH	GEL	DWB	JWH	GEL	DWB	JWH	GEL	DWB
10 03 06	22 6 06	27 11 02	28 NOV 02	28 NOV 02	28 NOV 02	28 NOV 02	28 NOV 02	28 NOV 02	28 NOV 02	28 NOV 02	28 NOV 02

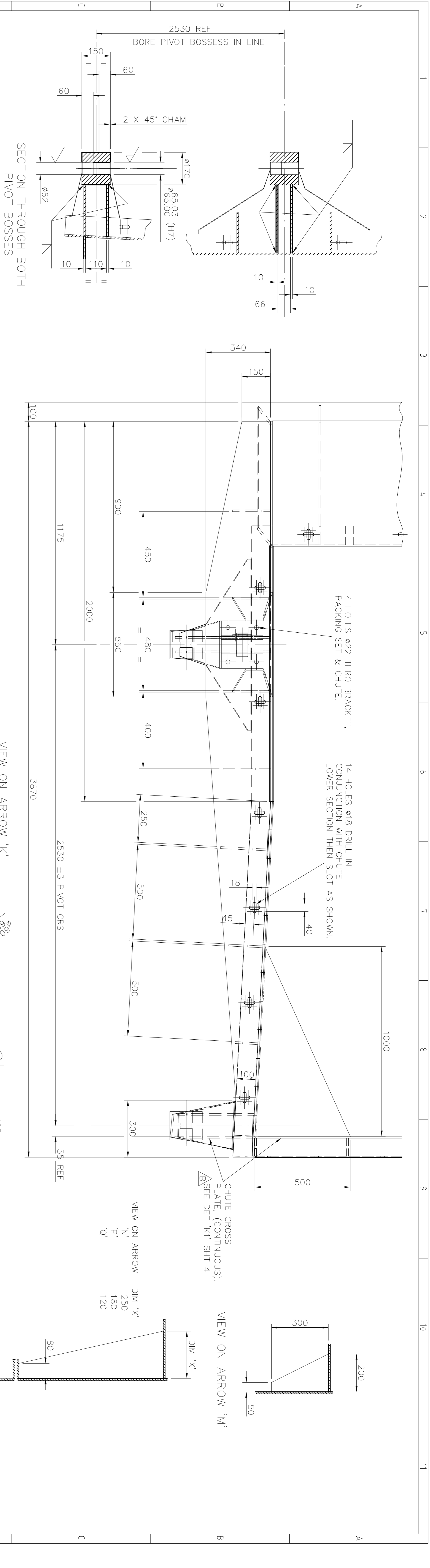

9
20 NOM PACKING
COMPRISING:
10 THK 1 REOD
6 THK 2 REOD
3 THK 3 REOD

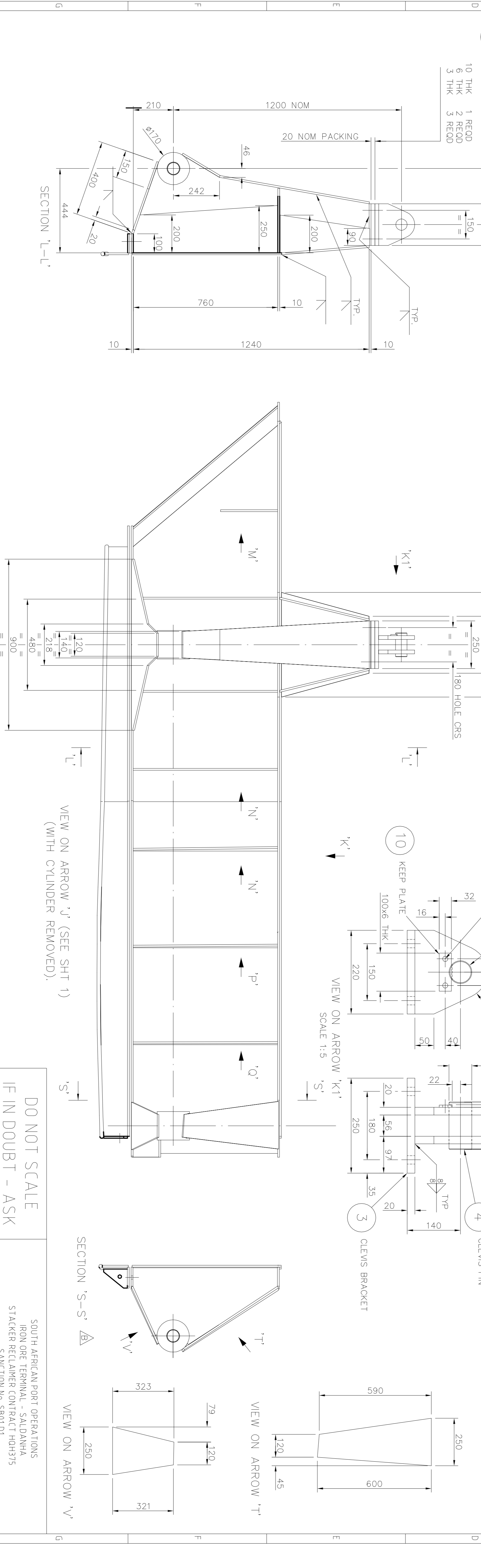

ISSUES RAISED GEN. UPDATE ADD SHEETS 7 & 8 SPILLAGE MOD TO CONTROL SPILLAGE BETWEEN CHUTE & BUCKET WHEEL AS BUILT	ISSUES RAISED GEN. UPDATE ADD SHEETS 7 & 8 SPILLAGE MOD TO CONTROL SPILLAGE BETWEEN CHUTE & BUCKET WHEEL AS BUILT	SECTION S-S MODIFIED	FIRST ISSUE
DRWN: DDB CHKD: RD DATE: 10.03.06	DRWN: RD CHKD: JWH DATE: 22.6.06	DRWN: GBL CHKD: DWB DATE: 27 NOV 02	DRWN: GBL CHKD: DWB DATE: 26/6/02
DRWN: JWH CHKD: JWH DATE: 21/11/02	DRWN: GBL CHKD: DWB DATE: 16 Sept 02	DRWN: GBL CHKD: DWB DATE: 5 Sept 02	DRWN: GBL CHKD: DWB DATE: 5 Sept 02

metso minerals

SOUTH AFRICAN PORT OPERATIONS
IRON ORE TERMINAL - SALDANHA
STACKER RECLAIMER CONTRACT HQH375
SANCTION NO. SB01D1

METSO MINERALS (UK) LTD
BUCK MATERIALS HANDLING BRISTOL
PO BOX 821 ASHTON VALE RD
BRISTOL BS99 5ZB ENGLAND

TITLE: SALDANHA BAY STACKER RECLAIMER ASSEMBLY & DETAILS OF BUCKET/WHEEL CHUTE

SIZE: DRAWING NUMBER 700457

DRWN: JWH CHKD: JWH DATE: 21/11/02	DRWN: GBL CHKD: DWB DATE: 16 Sept 02	DRWN: GBL CHKD: DWB DATE: 5 Sept 02	DRWN: GBL CHKD: DWB DATE: 5 Sept 02
DRWN: DDB CHKD: RD DATE: 10.03.06	DRWN: RD CHKD: JWH DATE: 22.6.06	DRWN: GBL CHKD: DWB DATE: 27 NOV 02	DRWN: GBL CHKD: DWB DATE: 26/6/02

1 2 3 4 5 6 7 8 9 10 11

1003 Saldanha Rev 3

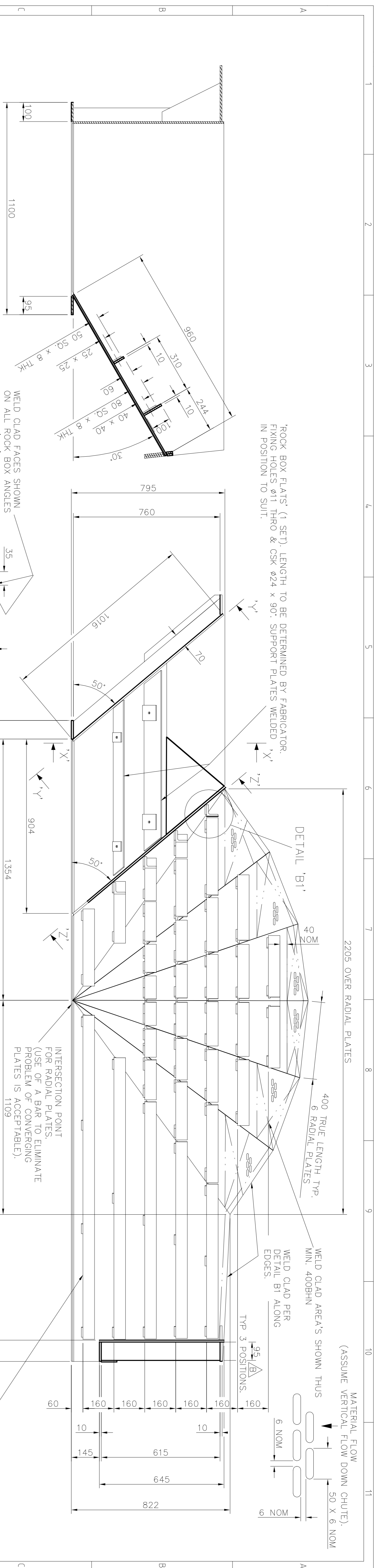

50x50x8 SUPPORT PLATE
 WELDED TO CHUTE.
 1 HOLE RECD $\phi 11$ DRILLED
 CENTRALLY IN PLATE

DETAIL 'B1'
 SCALE 1:5

SECTION 'W-W' (SEE SHT 1)

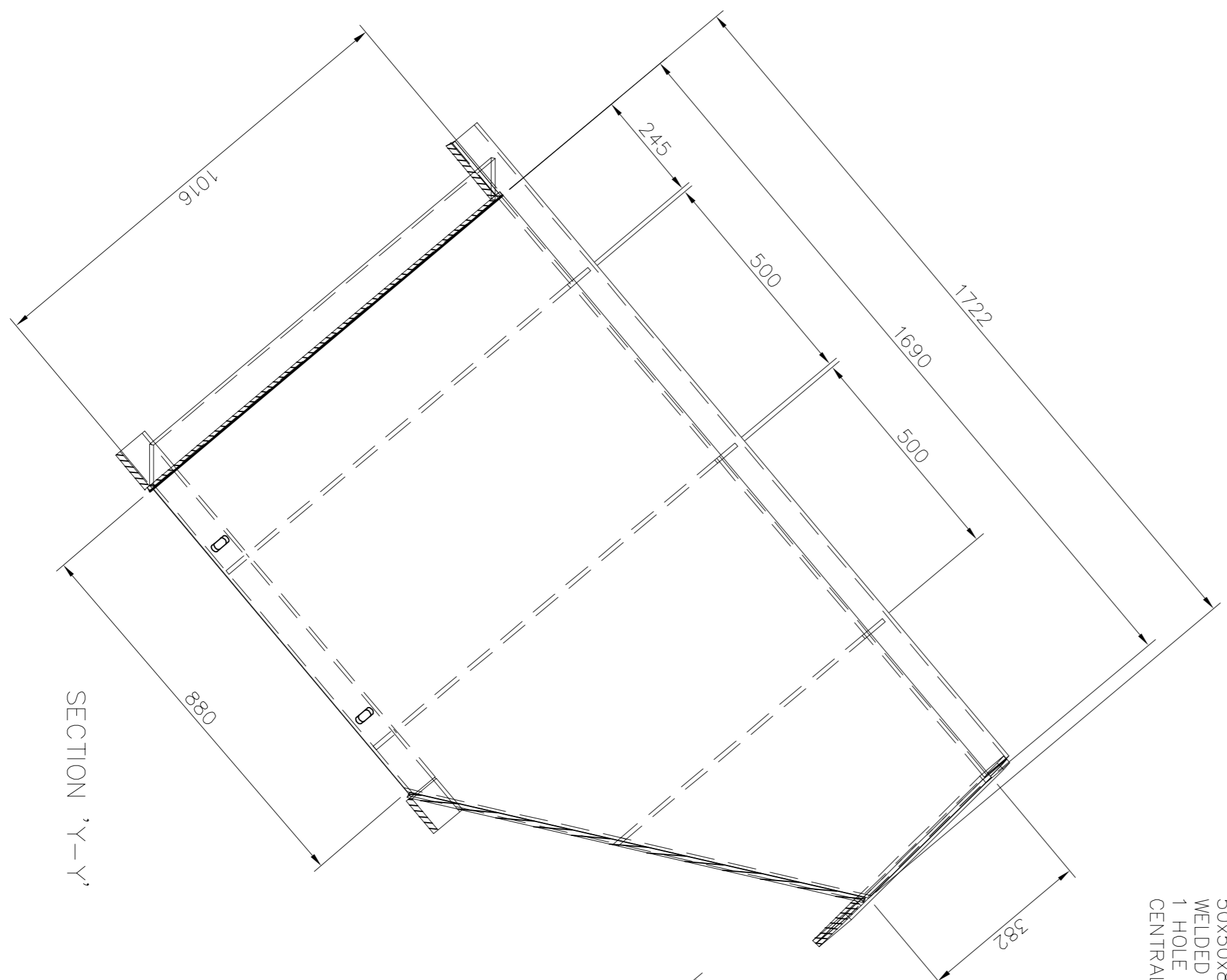

SECTION 'Y-Y'

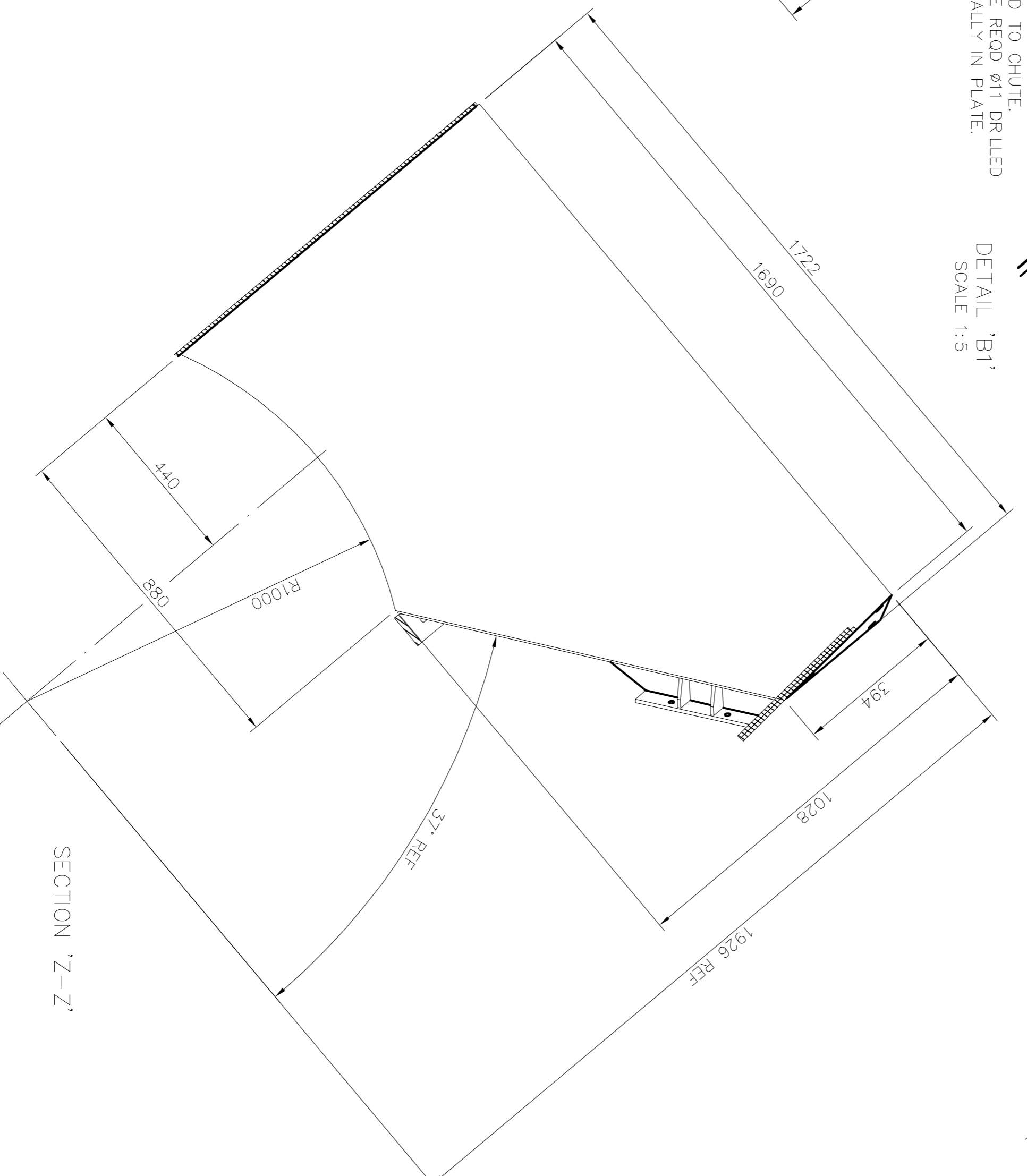

SECTION 'Z-Z'

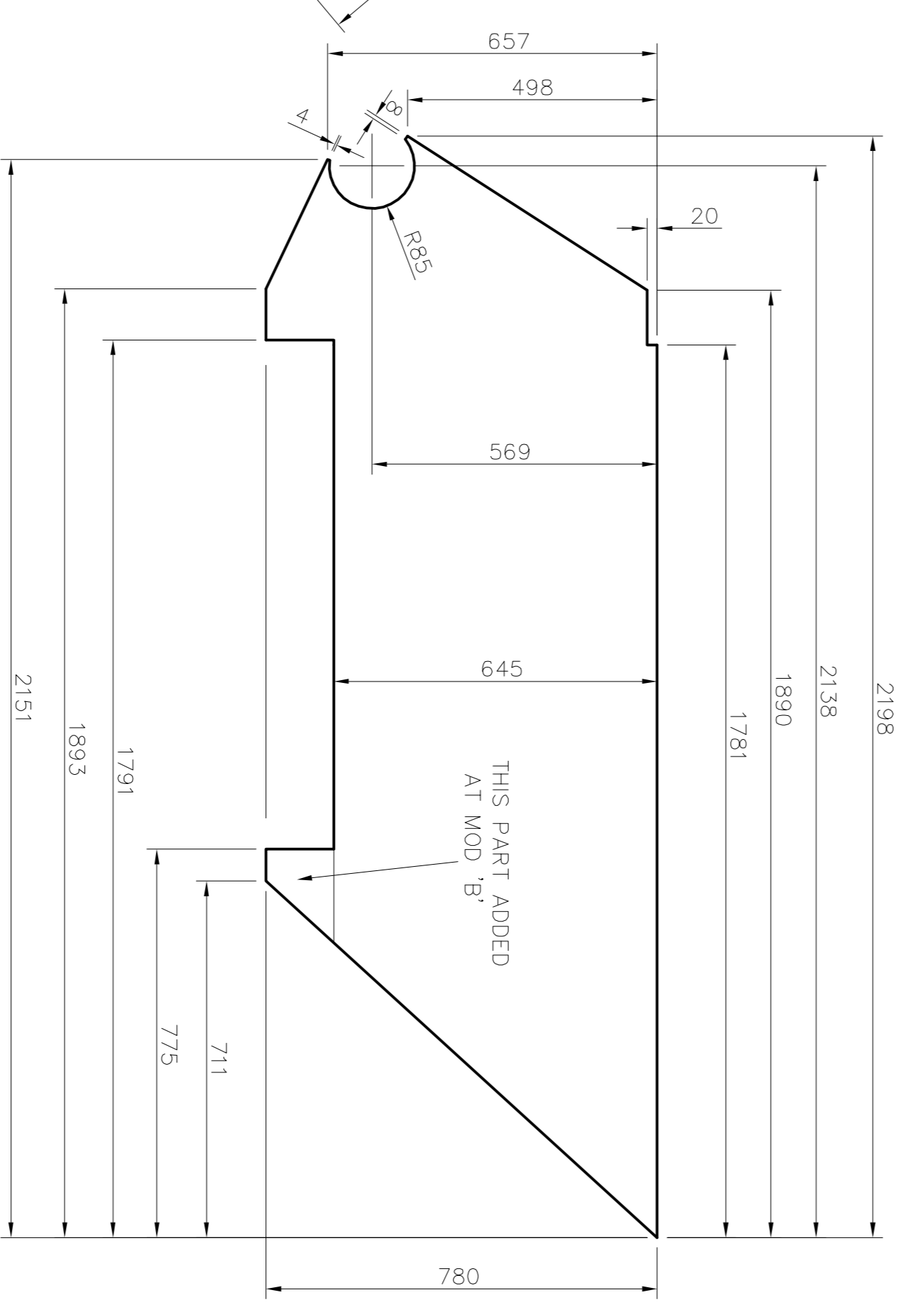

DETAIL 'K1' (SEE SHT 2)
 CHUTE FRONT PLATE

5 60 x 60 x 10 'ROCK BOX' ANGLES (1 SET). LENGTH OF EACH TO BE DETERMINED BY FABRICATOR. FIXING HOLES TO BE $\phi 11$ THRO & CSK $\phi 24$ x 90°. HOLES TO BE POSITIONED 35mm FROM ENDS OF ANGLES. ANGLES WITH ADDITIONAL FIXINGS TO BE EQUALLY SPACED BETWEEN END HOLES. SUPPORT PLATE TO BE POSITIONED TO SUIT SEE DETAIL 'B1'.

ISSUES RAISED GEN. UPDATE. ADD SHEETS 7 & 8. MOD TO CONTROL SPILLAGE BETWEEN CHUTE & BUCKET WHEEL AS BUILT

DETAIL 'K1' ADDED - CHUTE FRONT PLATE WITH MODIFIED PORTION SHOWN. WIDTH OF FLATS INCREASED SEE LOC A10.

FIRST ISSUE

UNLESS OTHERWISE SPECIFIED IDENTIFY THE ITEM WITH THE DRAWING NUMBER, DIMENSION AND UNIT OF MEASURE. SHOW DIMENSIONS FOR PAINTING AND FOR LUBRICATION SPECIFICATIONS SEE COMPONENTS LIST
 UNLESS OTHERWISE STATED DIMENSIONS ARE IN MILLIMETRES
 TOLERANCES UNLESS OTHERWISE STATED PLUS OR MINUS:

0-500	±0.25
501-1000	±0.5
1001-2000	±1.0
ABOVE 2000	±2.0

 This print and all the information hereon is the property of Metso Minerals Handling Bristol and must not be made public, copied or used in any way detrimental to our interest. It is loaned subject to return on demand unless furnished under contract provisions.

DO NOT SCALE
 IF IN DOUBT - ASK

SOUTH AFRICAN PORT OPERATIONS
 IRON ORE TERMINAL - SALDANHA
 STACKER RECLAIMER CONTRACT H0H375
 SANCTION No. SB01 D1



METSO MINERALS (UK LTD)
 BULK MATERIALS HANDLING BRISTOL
 PO BOX 821 ASHTON VALE RD
 BRISTOL BS99 5ZB ENGLAND

TITLE SALDANHA BAY STACKER RECLAIMER ASSEMBLY & DETAILS OF BUCKETWHEEL CHUTE

BRANCH	CHECKED	APPROVED	BRANCH	CHECKED	APPROVED	BRANCH	CHECKED	APPROVED	BRANCH	CHECKED	APPROVED
DATE	DATE	DATE	DATE	DATE	DATE	DATE	DATE	DATE	DATE	DATE	DATE
BRANCH	DATE	DATE	BRANCH	DATE	DATE	BRANCH	DATE	DATE	BRANCH	DATE	DATE
DDB	10/03/06		RD	22/6/06		JWH	22/6/06		GBL	21/11/02	

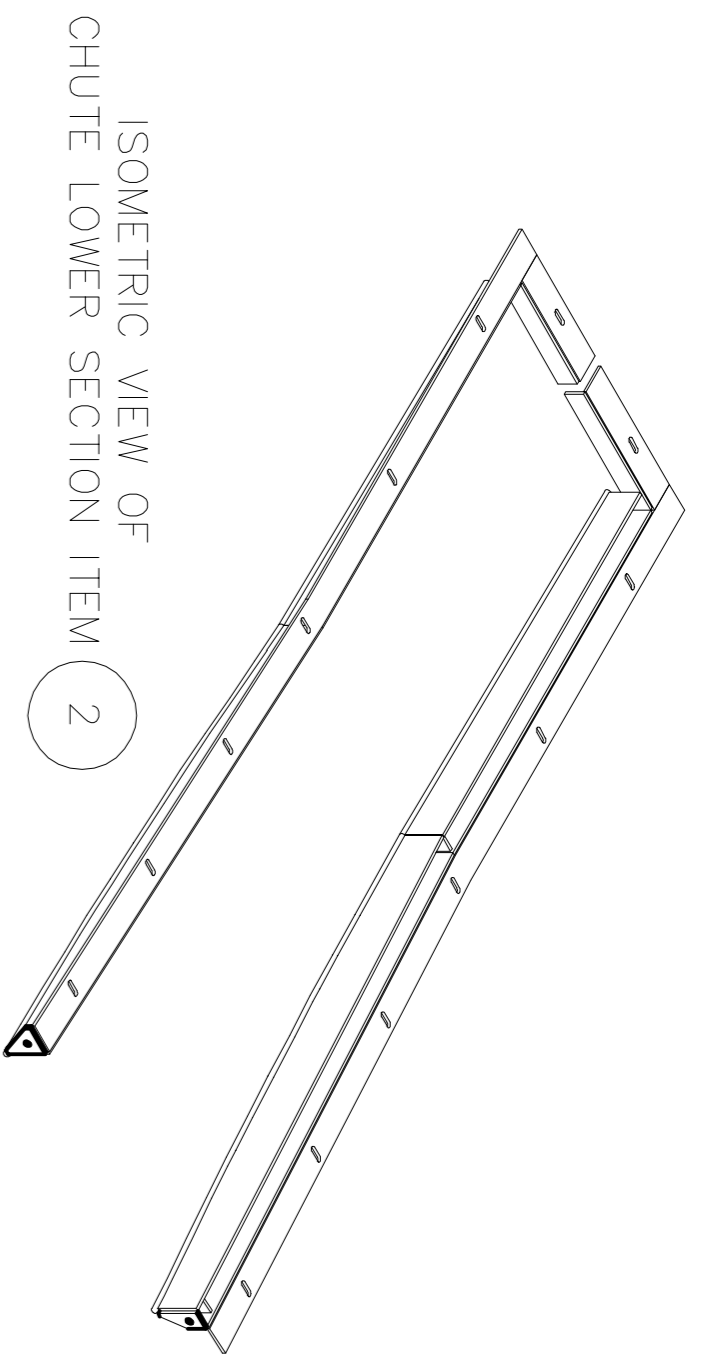

ISOMETRIC VIEW OF CHUTE LOWER SECTION ITEM 2

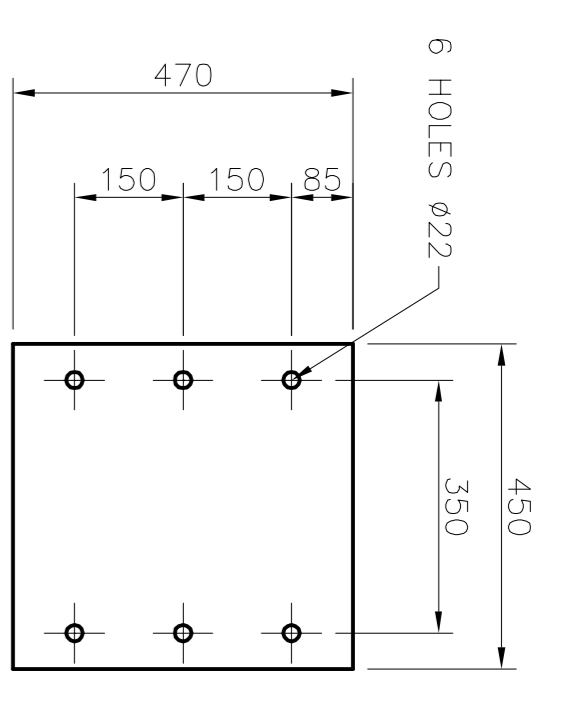

20 THK NOM PACKING SET ITEM 14
EACH PACKING SET CONSISTS OF 6 OFF X 5 THK PLATES
SCALE 1:5

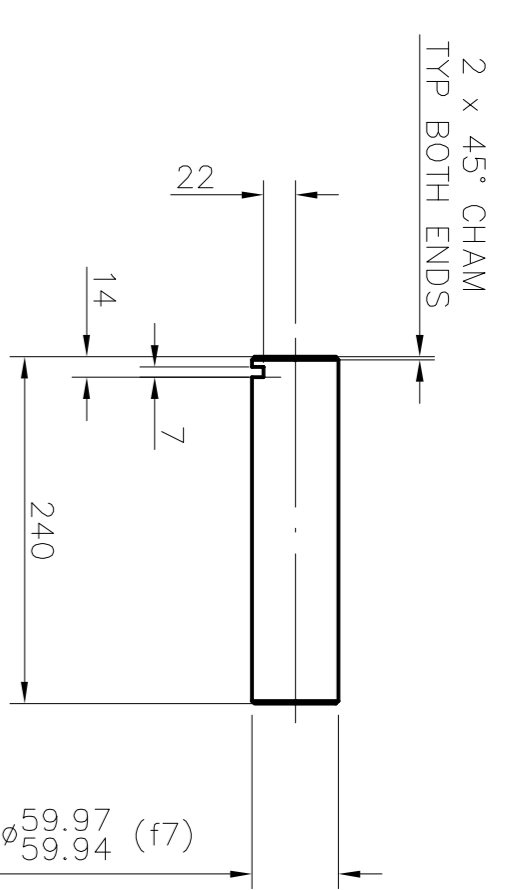

PIVOT PIN ITEM 15
SCALE 1:5

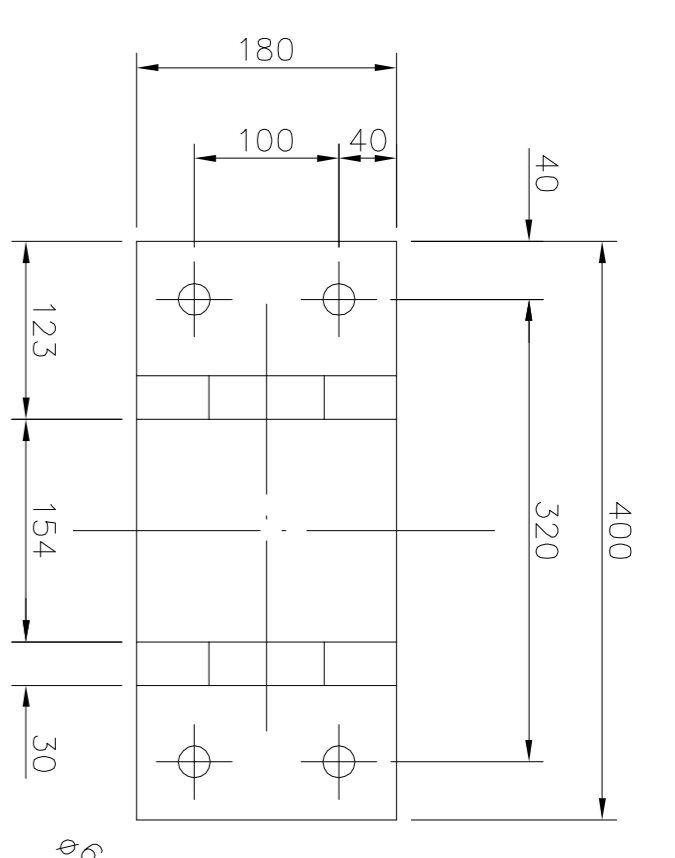

CHUTE PIVOT BRACKET ITEM 16
SCALE 1:5

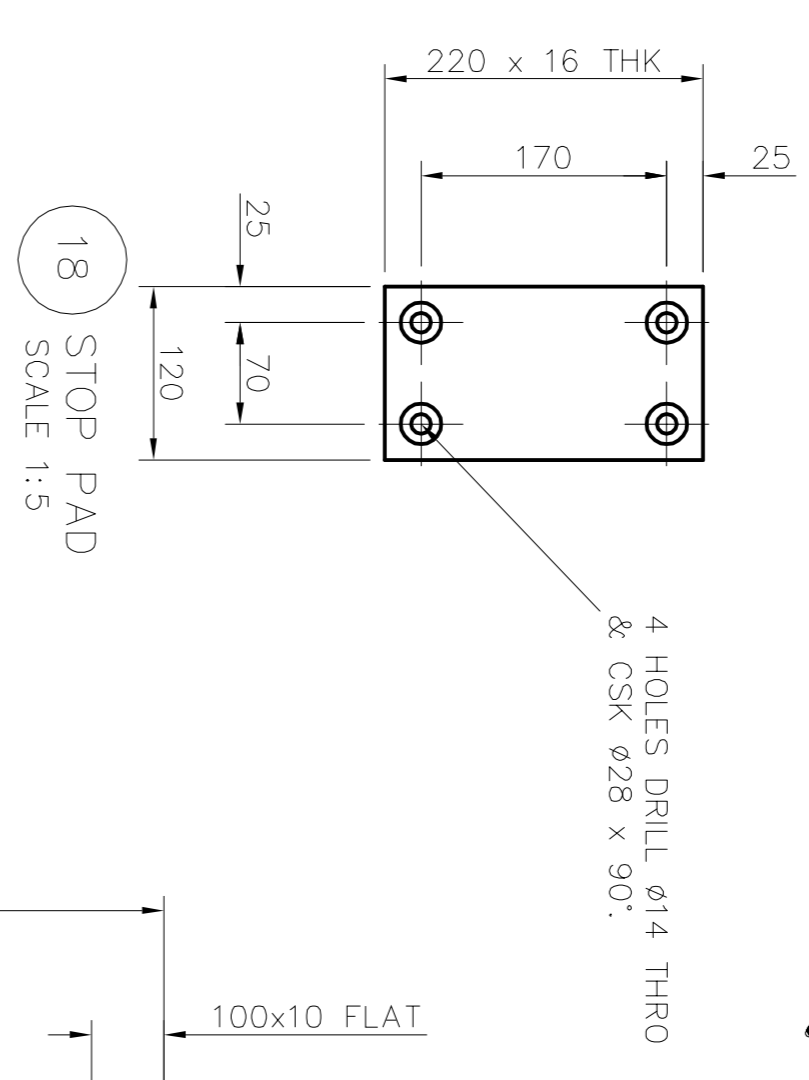
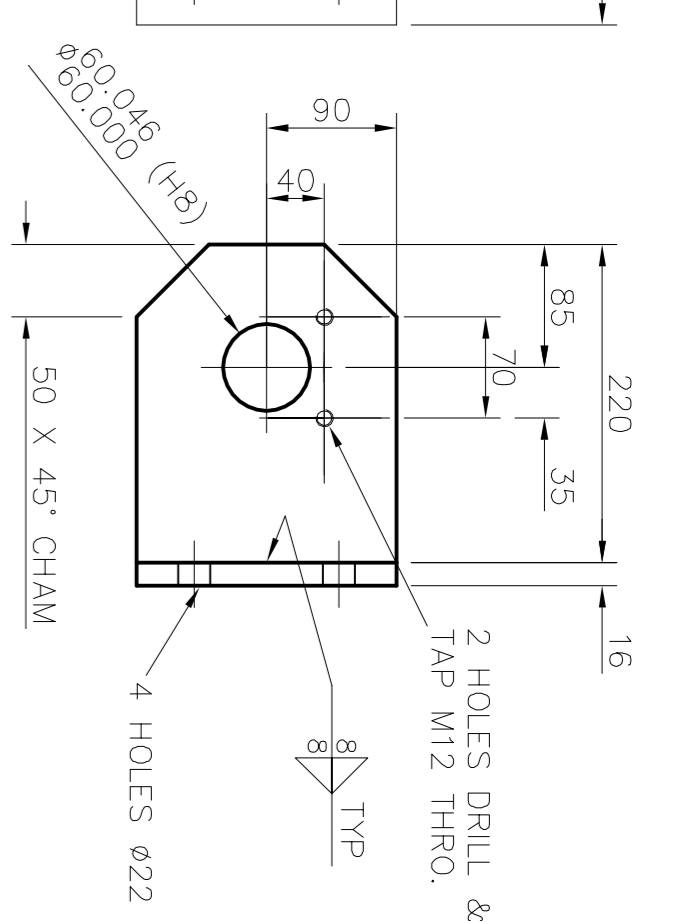

STOP PAD ITEM 18
SCALE 1:5

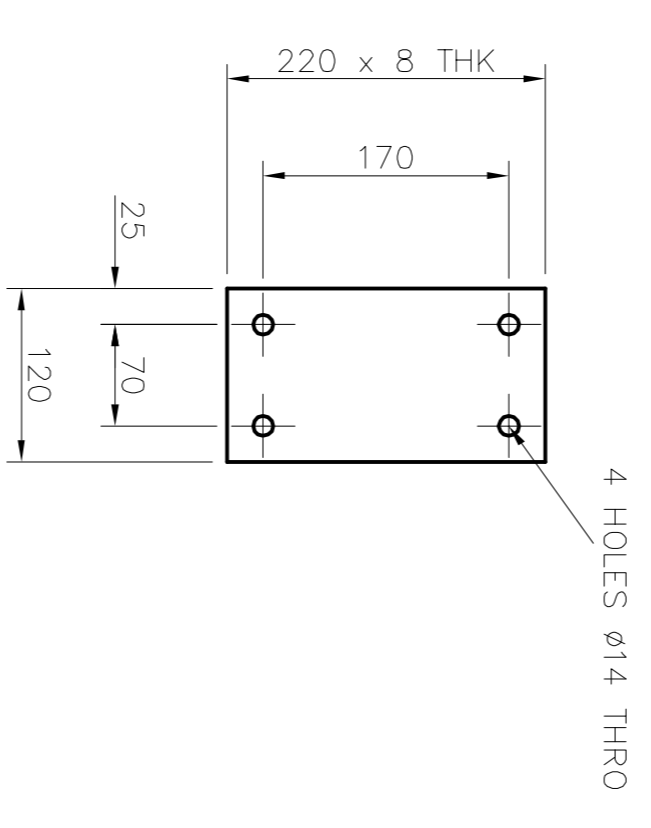

16 THK NOM PACKING ITEM 19
PACKING CONSISTS OF 4 OFF X 8 THK PLATES
SCALE 1:5

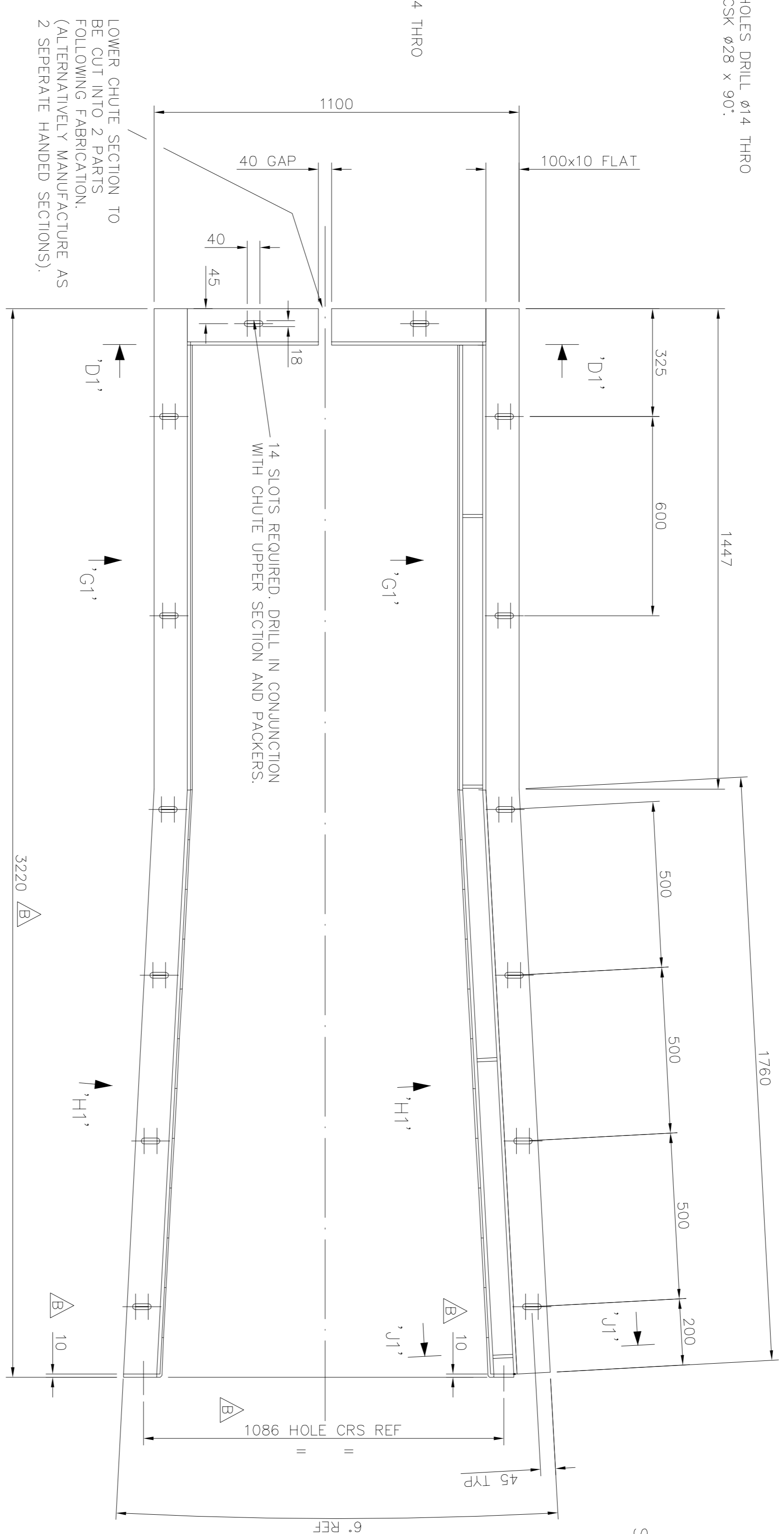

PLAN VIEW ON CHUTE LOWER SECTION ITEM 2
(INNER PROFILE SYMMETRICAL ABOUT HORIZONTAL CENTRE LINE)

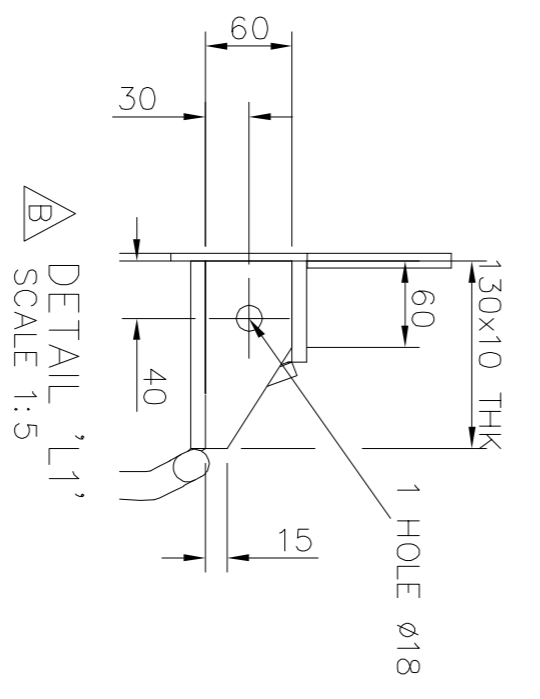

DETAIL 'L1'
SCALE 1:5

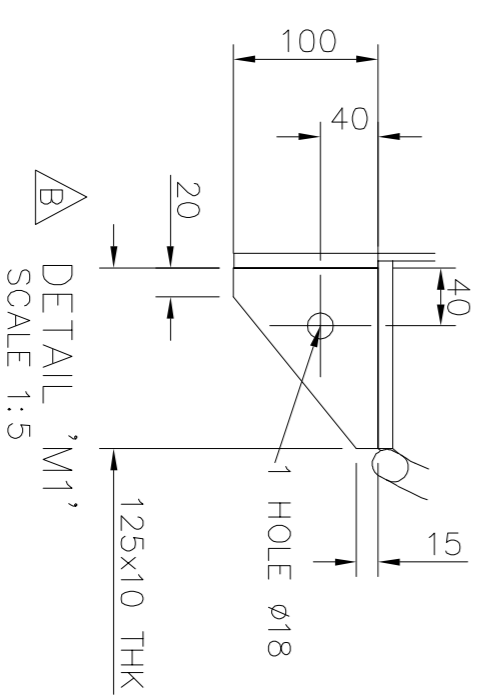

DETAIL 'M1'
SCALE 1:5

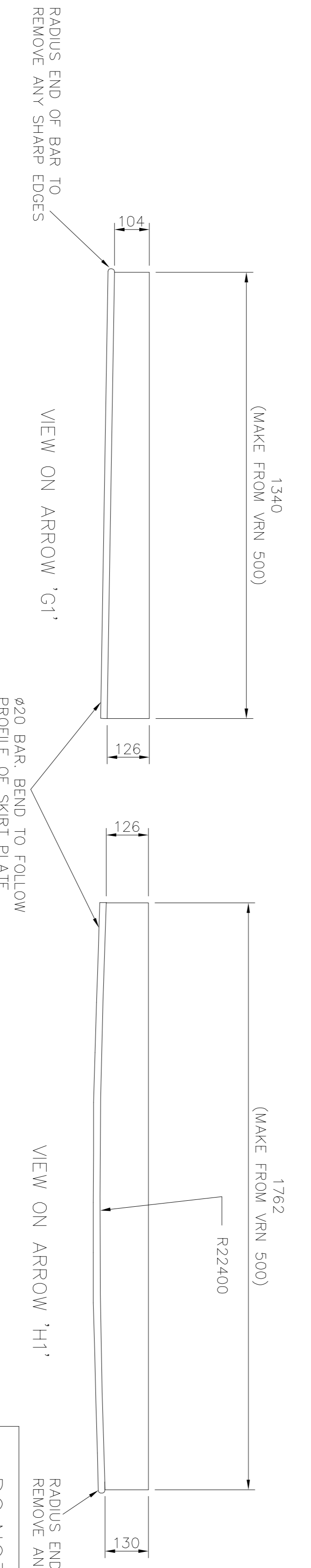

VIEW ON ARROW 'G1'
RADIUS END OF BAR TO REMOVE ANY SHARP EDGES

VIEW ON ARROW 'H1'
RADIUS END OF BAR TO REMOVE ANY SHARP EDGES

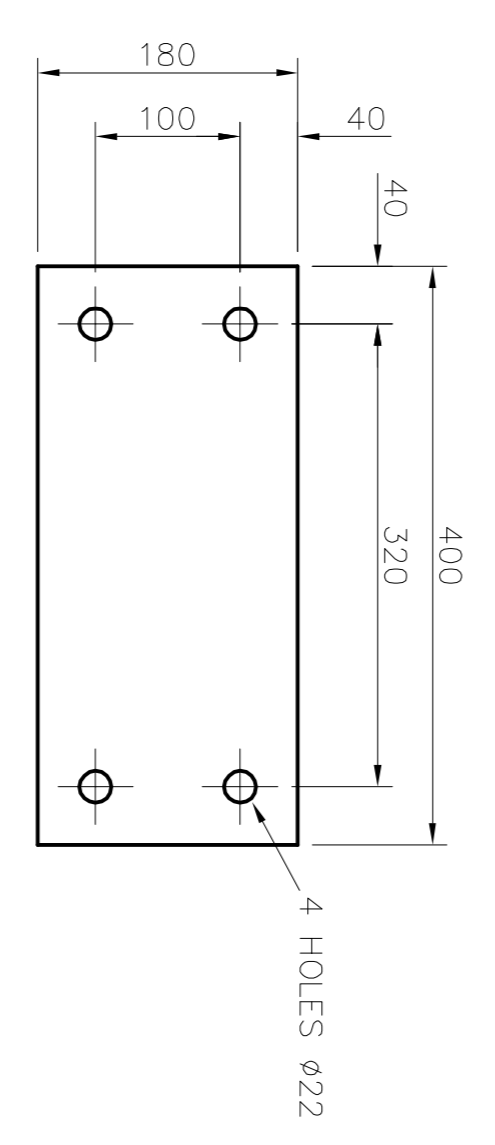

25 THK NOM PACKING SET ITEM 17
EACH SET CONSISTS OF 8 OFF X 5 THK PLATES
SCALE 1:5

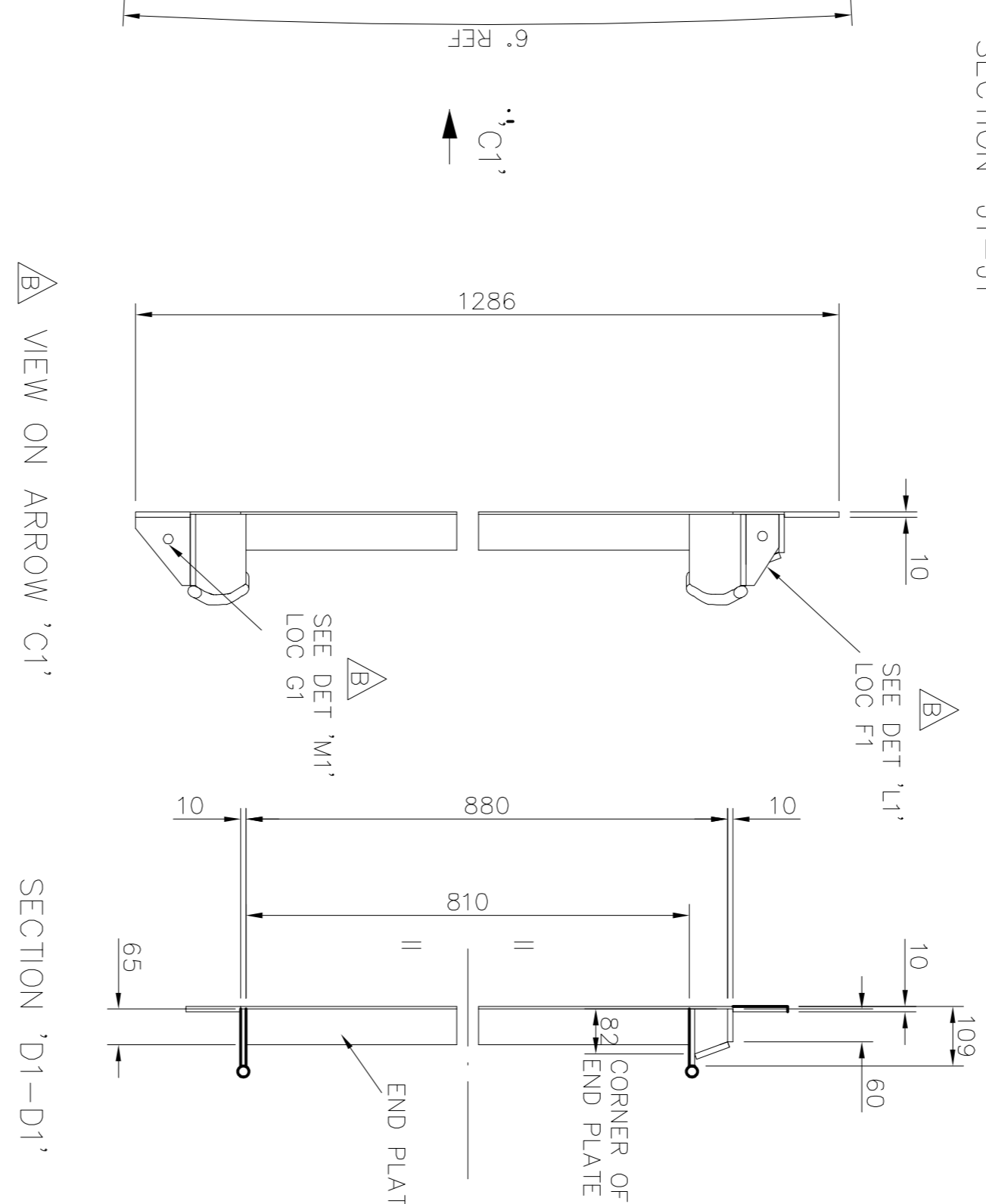

SECTION 'D1-D1'

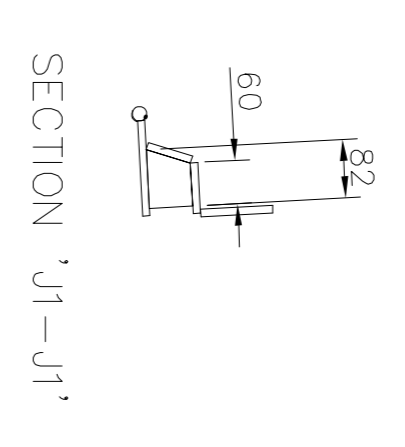

SECTION 'J1-J1'

DRAWN		CHECKED		APPROVED		DRAWN		CHECKED		APPROVED		DRAWN		CHECKED		APPROVED		DRAWN		CHECKED		APPROVED			
DATE		DATE		DATE		DATE		DATE		DATE		DATE		DATE		DATE		DATE		DATE		DATE		DATE	
1		2		3		4		5		6		7		8		9		10		11					

ISSUES RAISED GEN UPDATE.		ADD SHEETS 7 & 8.		MOD TO CONTROL SPILLAGE		BETWEEN CHUTE & BUCKET		WHEEL		AS BUILT	
DRAWN		DDB		RD		JWH		GBL		DWB	
DATE		10/03/06		DATE		22/6/06		DATE		27/11/02	
CHECKED		RD		JWH		GBL		DWB		JWH	
DATE		22/6/06		DATE		21/11/02		DATE		28/11/02	
APPROVED		DDB		RD		JWH		GBL		DWB	
DATE		10/03/06		DATE		22/6/06		DATE		27/11/02	
APPROVED		DDB		RD		JWH		GBL		DWB	
DATE		10/03/06		DATE		22/6/06		DATE		27/11/02	
APPROVED		DDB		RD		JWH		GBL		DWB	
DATE		10/03/06		DATE		22/6/06		DATE		27/11/02	
APPROVED		DDB		RD		JWH		GBL		DWB	
DATE		10/03/06		DATE		22/6/06		DATE		27/11/02	

UNLESS OTHERWISE SPECIFIED DENOTE THE ITEM WITH THE DRAWING NUMBER AND ISSUE LEVEL AS SHOWN IN THE MANNER SHOWN FOR PAINTING AND FOR LUBRICATION SPECIFICATIONS SEE COMPONENTS LIST		UNLESS OTHERWISE STATED DIMENSIONS ARE IN MILLIMETRES	
TOLERANCES UNLESS OTHERWISE SPECIFIED		TOLERANCES UNLESS OTHERWISE SPECIFIED	
FINISH	GRADE	FINISH	GRADE
0-500	0.25	0-500	0.25
501-1000	0.5	501-1000	0.5
1001-2000	1.0	1001-2000	1.0
ABOVE 2000	2.0	ABOVE 2000	2.0

DRAWN TO BS 8888		THIRD ANGLE	
WELD SYMBOLS TO BS EN 22553		PROJ	
SURFACE TEXTURE TO BS 1134		PROJ	
MATERIAL & CONDITION BEFORE MANUFACTURE			

SOUTH AFRICAN PORT OPERATIONS		IRON ORE TERMINAL - SALDANHA	
STACKER RECLAIMER CONTRACT HQH375		SANCTION No. SB01 D1	
METSO MINERALS (UK) LTD		METSO MINERALS HANDLING BRISTOL	
PO BOX 821 ASHTON VALE RD		BRISTOL BS99 5ZB ENGLAND	

DO NOT SCALE		IF IN DOUBT - ASK	
TITLE		SALDANHA BAY STACKER RECLAIMER ASSEMBLY & DETAILS OF BUCKETWHEEL CHUTE	
MATERIAL		METSO	
SPEC		700457	
GRADE		A1	
NOTES			
MASS		kg	
ORIGINAL SCALE		1:10 UOS	
SIZE		A1	
DRAWING NUMBER		700457	
SHEET		5	
OF		8	
ISSUE		C	

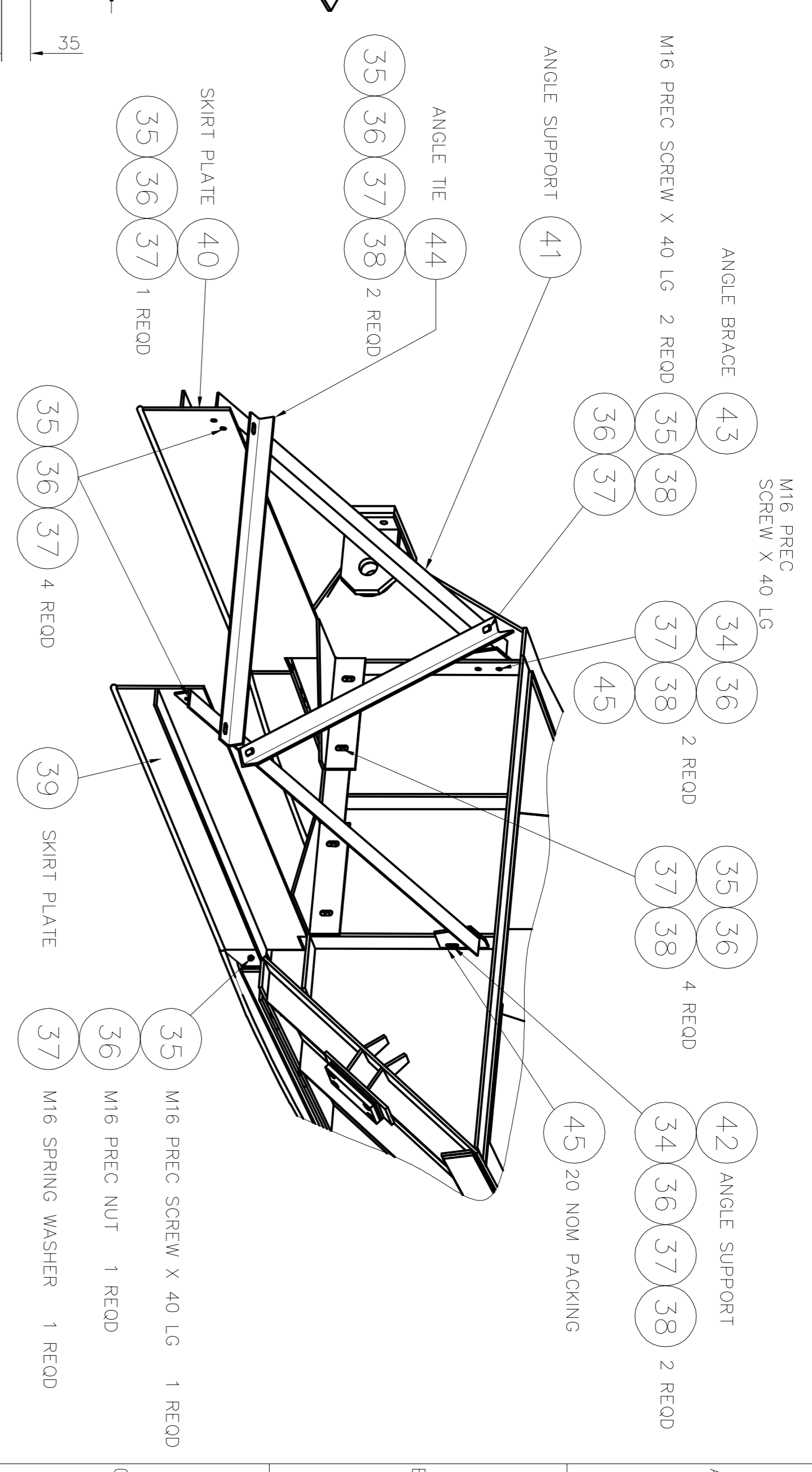
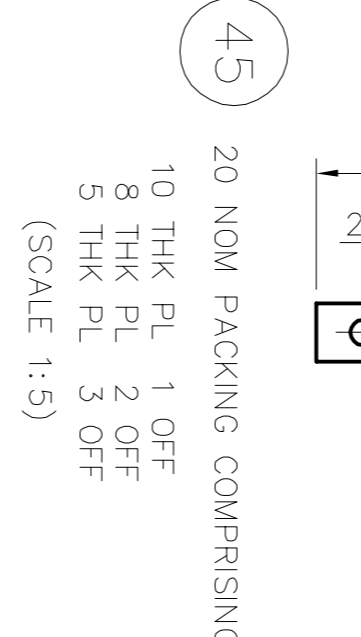
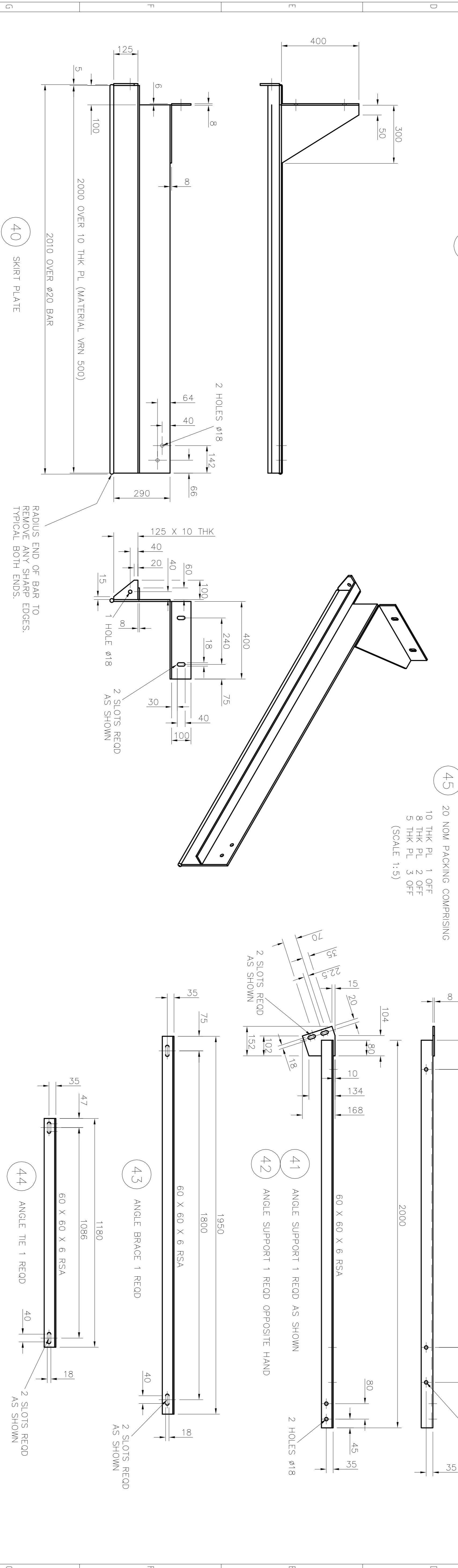
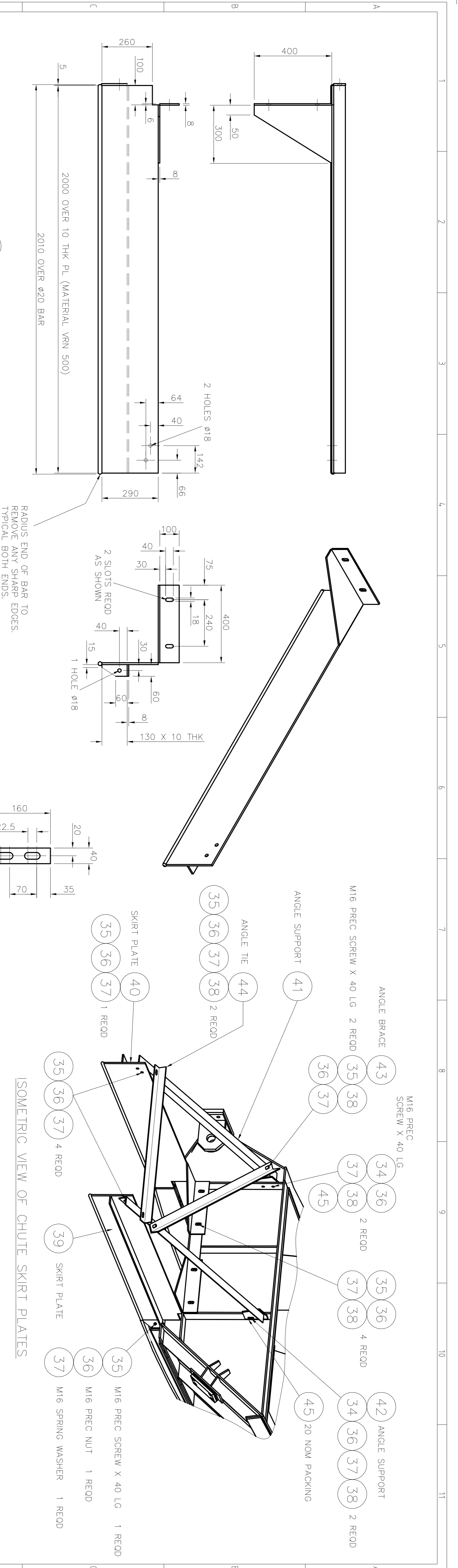

BRN	CHKD	APPROV	BRN	CHKD	APPROV	BRN	CHKD	APPROV	BRN	CHKD	APPROV	BRN	CHKD	APPROV	BRN	CHKD	APPROV	BRN	CHKD	APPROV
DATE	DATE	DATE	DATE	DATE	DATE	DATE	DATE	DATE	DATE	DATE	DATE	DATE	DATE	DATE	DATE	DATE	DATE	DATE	DATE	DATE

ISSUES RAISED GEN. UPDATE ADD SHEETS 7 & 8. MOD. TO CONTROL SPILLAGE BETWEEN CHUTE & BUCKET AS BUILT

SHEET 6 ADDED.

UNLESS OTHERWISE SPECIFIED IDENTIFY THE ITEM WITH THE DRAWING NUMBER AND ISSUE LEVEL AT \blacktriangledown AND IN THE MANNER SHOWN FOR PAINTING AND FOR LUBRICATION SPECIFICATIONS SEE COMPONENTS LIST

UNLESS OTHERWISE STATED DIMENSIONS ARE IN MILLIMETRES TOLERANCES UNLESS OTHERWISE STATED (PLUS OR MINUS)

RANGE	MACH	FAB	CAST
0-500	0.25	2	2
501-1000	0.5	3	4
1001-2000	1.0	4	6
2001-2800	2.0	6	10

THIS PRINT AND ALL THE INFORMATION HEREON IS THE PROPERTY OF METSO MINERALS. METSO MINERALS SHALL BE RESPONSIBLE FOR THE DESIGN, MANUFACTURE, AND INSTALLATION OF THIS EQUIPMENT. METSO MINERALS SHALL BE RESPONSIBLE FOR THE DESIGN, MANUFACTURE, AND INSTALLATION OF THIS EQUIPMENT. METSO MINERALS SHALL BE RESPONSIBLE FOR THE DESIGN, MANUFACTURE, AND INSTALLATION OF THIS EQUIPMENT.

DO NOT SCALE IF IN DOUBT - ASK

metso minerals

SALDANHA BAY STACKER RECLAIMER ASSEMBLY & DETAILS OF BUCKET/WHEEL CHUTE

SOUTH AFRICAN PORT OPERATIONS
IRON ORE TERMINAL - SALDANHA
STACKER RECLAIMER CONTRACT HH375
SANCTION NO. SB01 D1

METSO MINERALS (UK) LTD
BULK MATERIALS HANDLING BRISTOL
PO BOX 872 ASHTON VALE RD
BRISTOL BS99 5ZB ENGLAND

DRAWN TO BS 8888
WELD SYMBOLS TO BS EN 2253 ANGLE
SURFACE TEXTURE TO BS 7193 (PROJ)
MATERIAL & CONDITION BEFORE MANUFACTURE

TITLE

MASS kg 1:10 UOS

SIZE DRAWING NUMBER A1 700457

SHEET 6 OF 8 ISSUE C

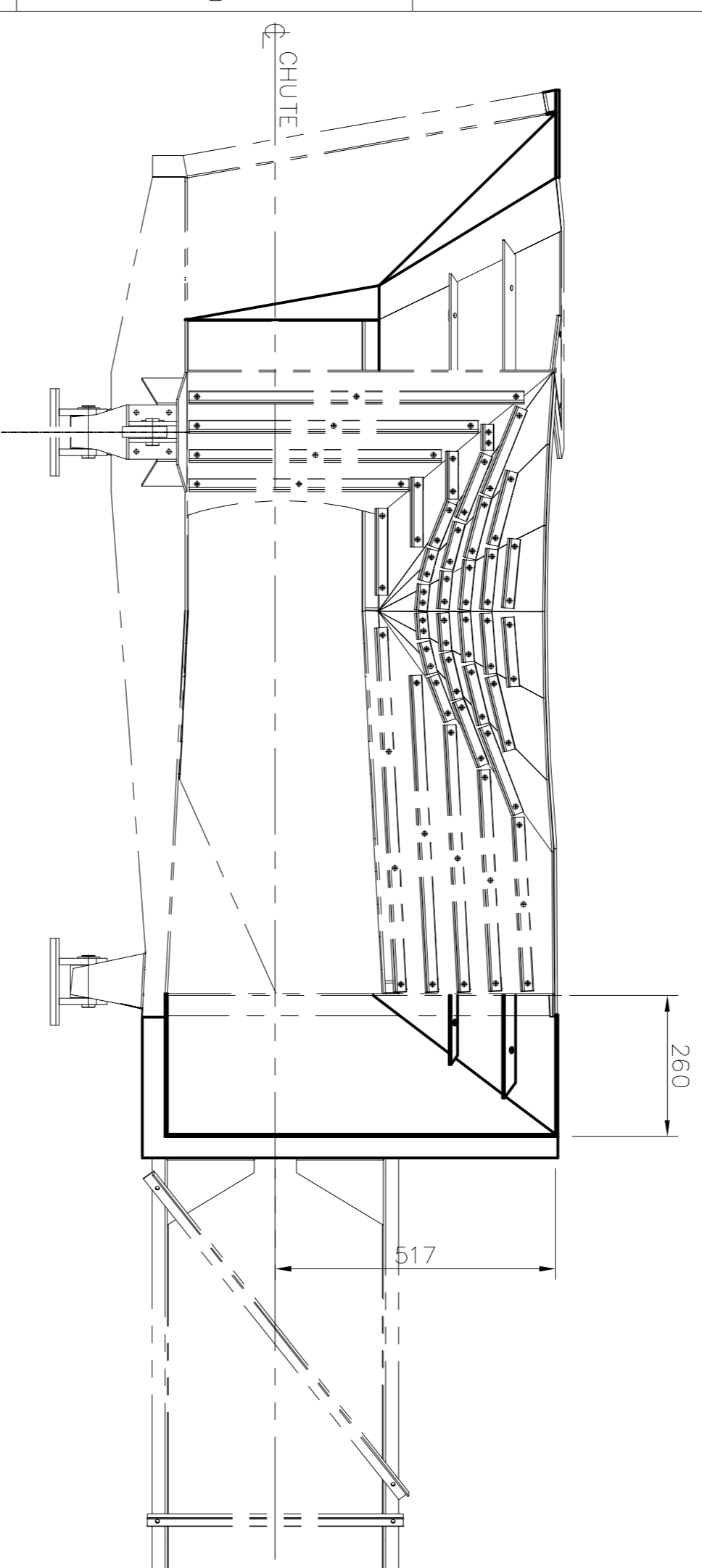
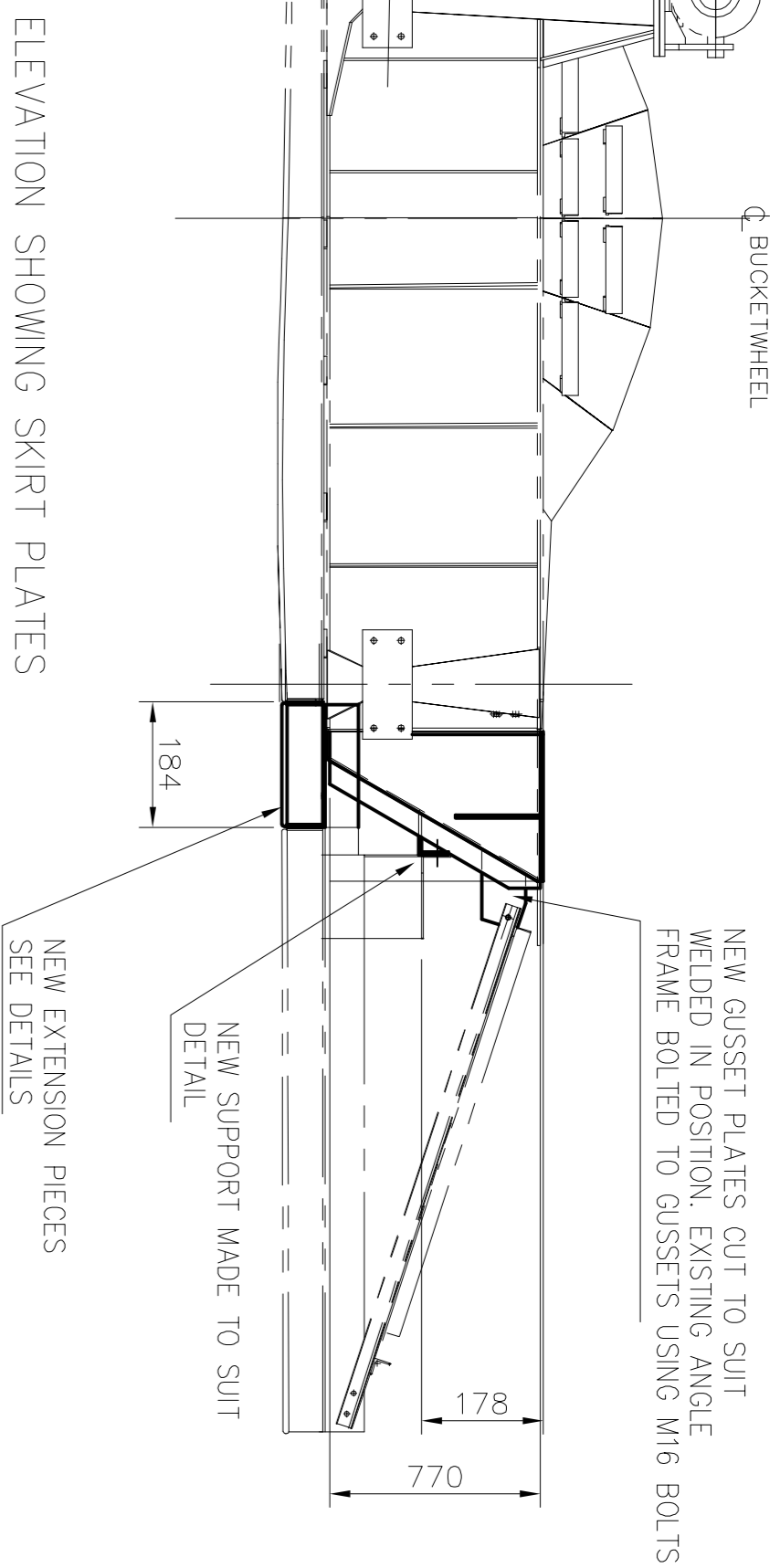

PLAN VIEW SHOWING SKIRT PLATES IN PLACE

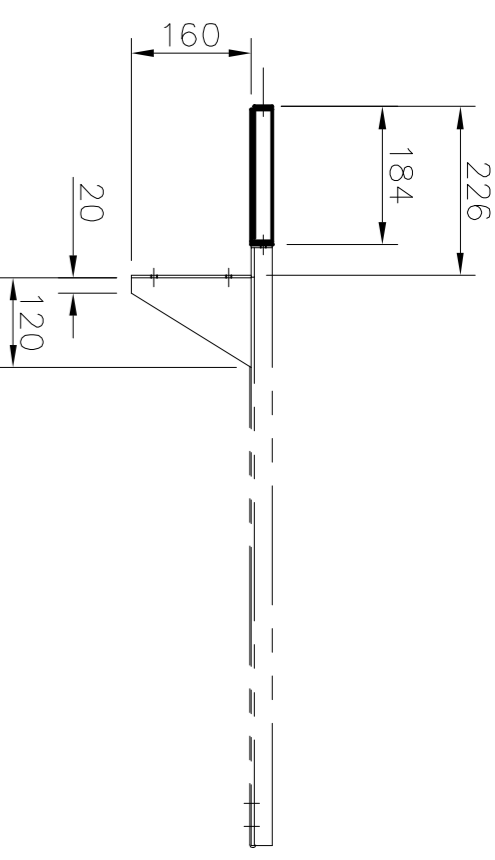

PLAN VIEW

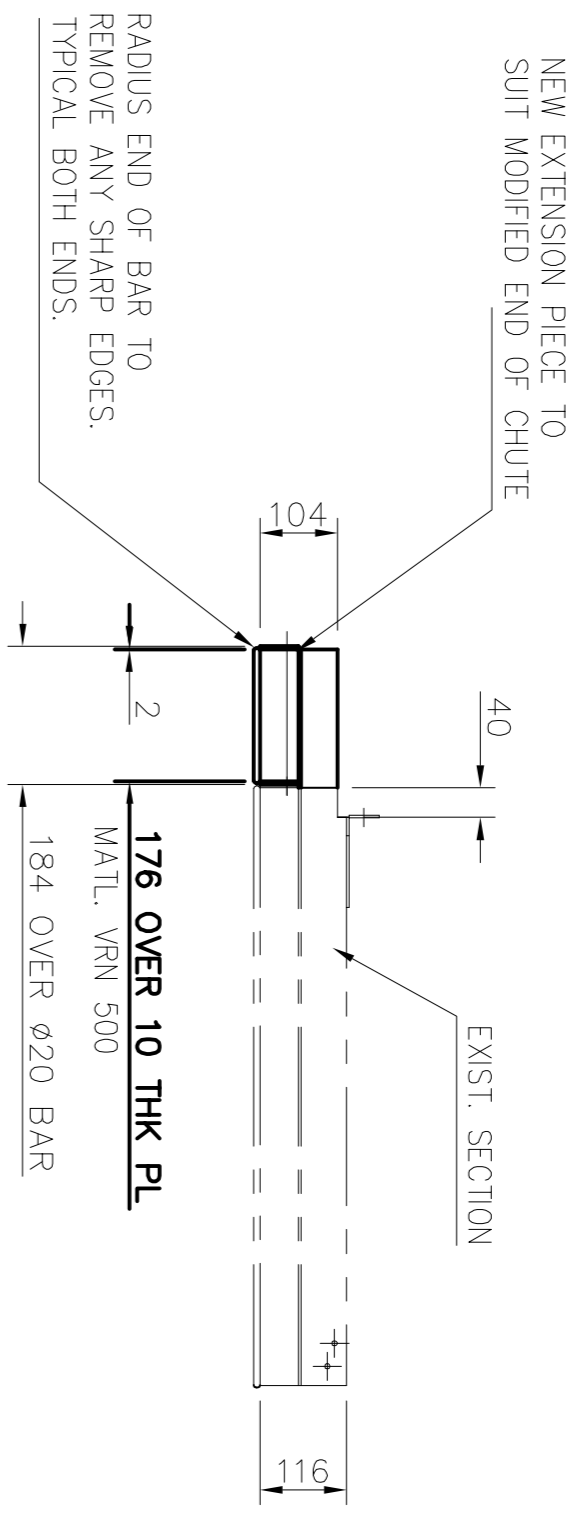

ELEVATION ON CHUTE SKIRT PLATES

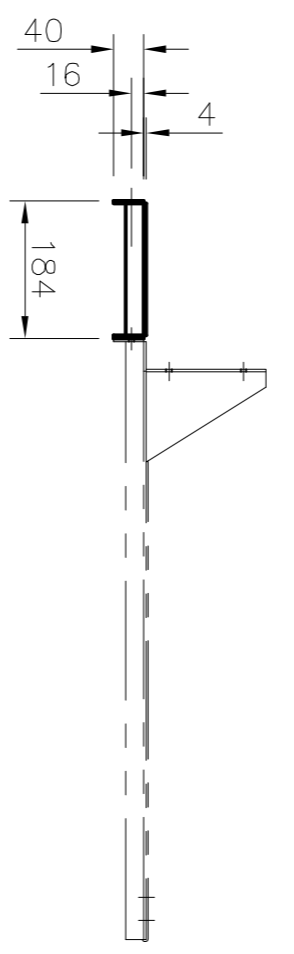

PLAN VIEW

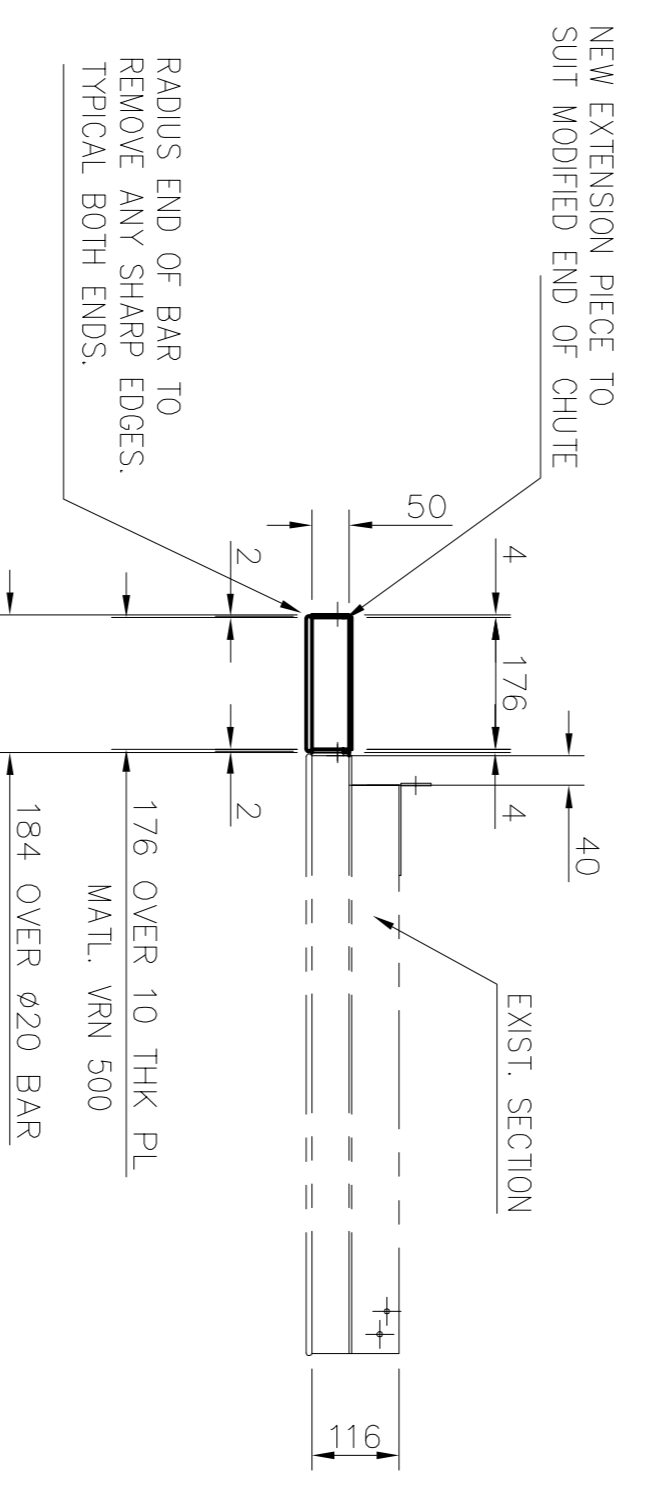

ELEVATION ON CHUTE SKIRT PLATES

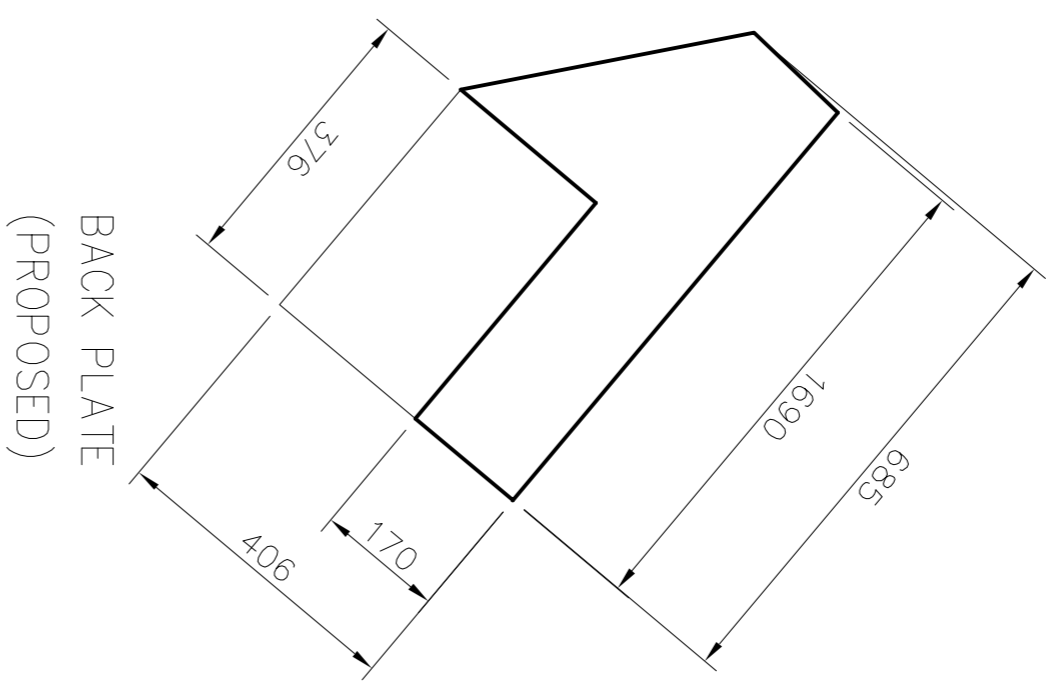
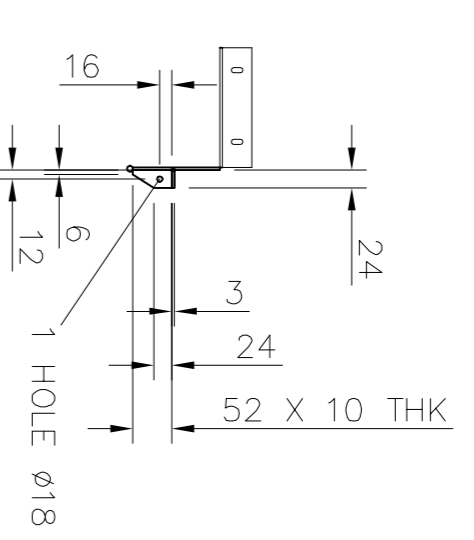
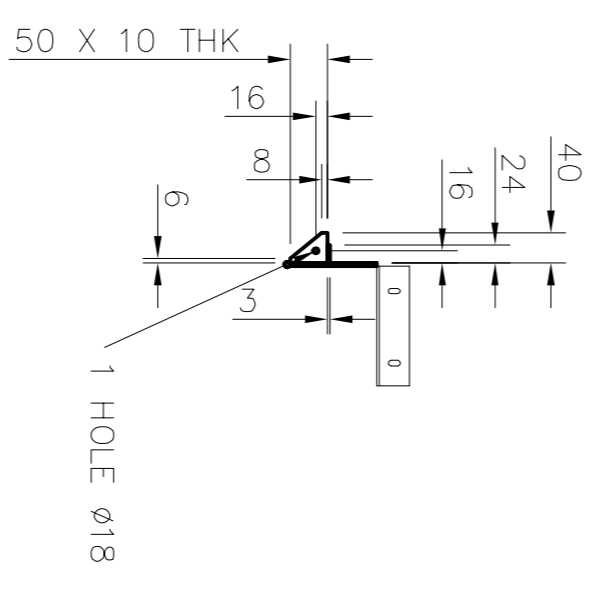

BACK PLATE (PROPOSED)

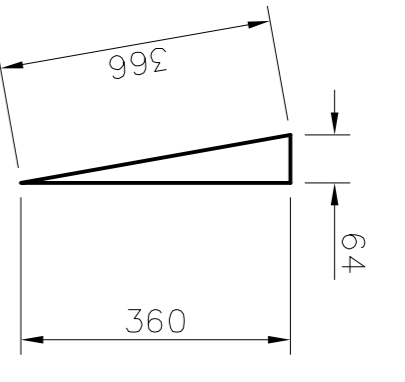

FLOOR PLATE (PROPOSED)

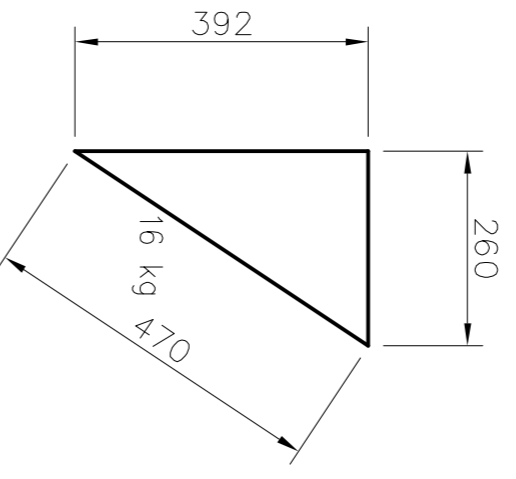

SIDE PLATE (PROPOSED)

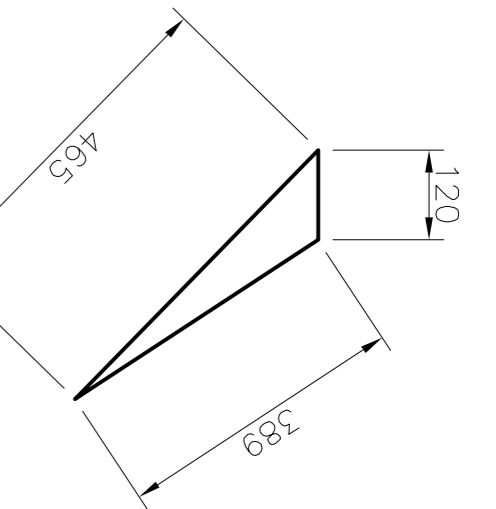

SIDE PLATE (PROPOSED)

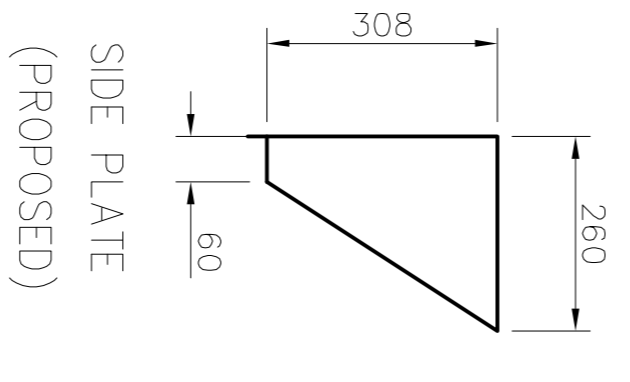

SIDE PLATE (PROPOSED)

ISSUES RAISED GEN. UPDATE ADD SHEETS 7 & 8 MOD. TO CONTROL SPILLAGE BETWEEN CHUTE & BUCKET AS BUILT

ADD NEW SH.6 & 7 EXIST. CHUTE DWG CHANGED EXIST. BEING MONITORED ON PROPOSED MODIFICATIONS.

ISSUED FOR COMMENT

DRAWN	CHECKED	APPROVED	DRAWN	CHECKED	APPROVED	DRAWN	CHECKED	APPROVED	DRAWN	CHECKED	APPROVED	DRAWN	CHECKED	APPROVED
DATE	DATE	DATE	DATE	DATE	DATE	DATE	DATE	DATE	DATE	DATE	DATE	DATE	DATE	DATE

DO NOT SCALE IF IN DOUBT - ASK

PLATEWORK VRN 500 10mm THK. - 2500x1225 sheet
100x10x12000 lg FLAT BAR @ 6.28 kg/m = 76 kg
TOTAL ADD ON MASS = 190 kg

SOUTH AFRICAN PORT OPERATIONS
IRON ORE TERMINAL - SALDANHA
STACKER RECLAIMER CONTRACT HQH375
SANCTION No. SB01 D1

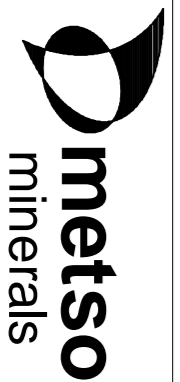

METSO MINERALS (UK) LTD
BULK MATERIALS HANDLING BRISTOL
PO BOX 821 ASHTON VALE RD
BRISTOL BS59 5ZB ENGLAND

SALDANHA BAY STACKER RECLAIMER
PROPOSED MODIFICATIONS TO BUCKET
WHEEL CHUTE - PLATES

MASS	ORIGINAL SCALE	SIZE	DRAWING NUMBER	SHEET OF	ISSUE
	1:25	A1	700457	7	8 C

180734184 REV 3

NOTES :-

THIS DRAWING TO BE READ IN CONJUNCTION WITH :-

A) DOCUMENT 27496/D15, MANUFACTURING SPECIFICATION.

1. MATERIAL: PLATES, FLATS, BARS & OPEN ROLLED SECTIONS TO SABS1431 GRADE 300MA (IUS ON COMPS LIST). WEAR & SKIRT PLATES TO BE VRN 500. GENERAL PLATE THICKNESS 10mm IUS.
2. CERTIFICATION: CHEMICAL & MECHANICAL TEST CERTIFICATES REQUIRED FOR ALL MATERIALS IN ACCORDANCE WITH MANUFACTURING SPECIFICATION.
3. WELDING: ALL WELDING TO BE CARRIED OUT IN ACCORDANCE WITH THE MANUFACTURING SPECIFICATION. ALL WELDS ARE TO BE BIRM CONTINUOUS FILLETS UNLESS OTHERWISE SPECIFIED.
4. SURFACE TREATMENT: TO CONFORM TO MANUFACTURING SPECIFICATION.
5. FOR INSTALLATION & SET UP WITH BUCKET/WHEEL & CONVEYOR, REFER TO ERECTION & COMMISSIONING SCHEDULES.

** SEE REF. DRAWINGS 700457 Sheets 1-6

** SEE REF. DRAWING SKETCH 1019

TOTAL MASS OF CHUTE STEELWORK 2390 Kg

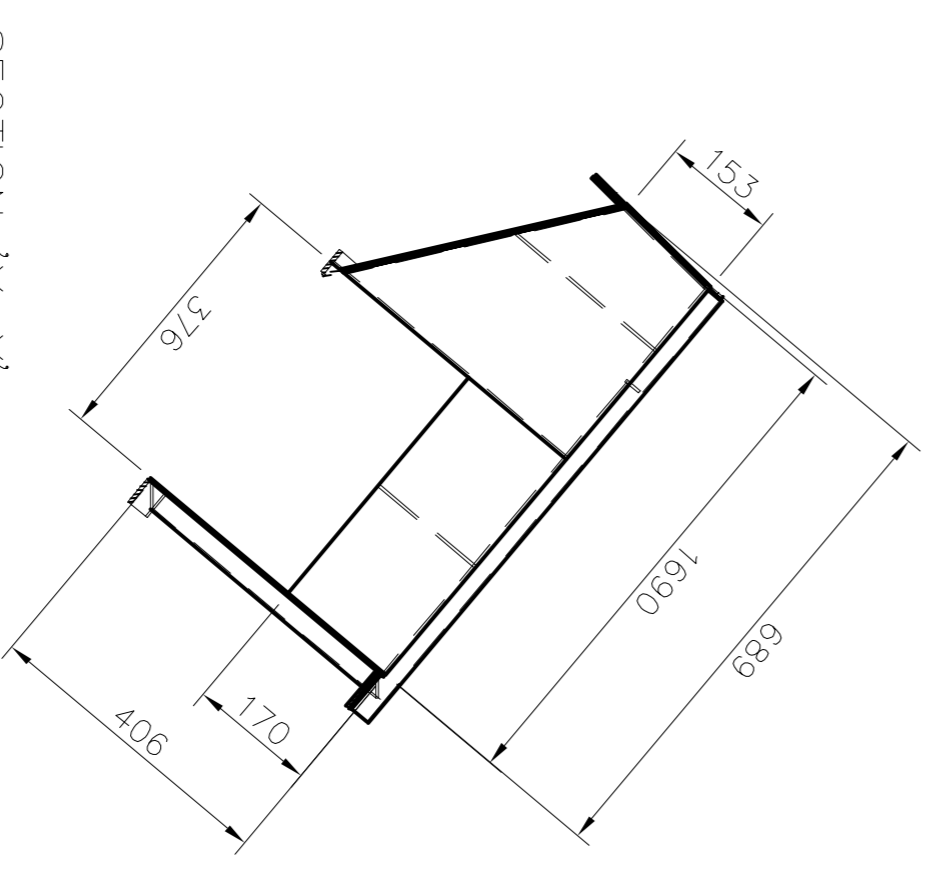
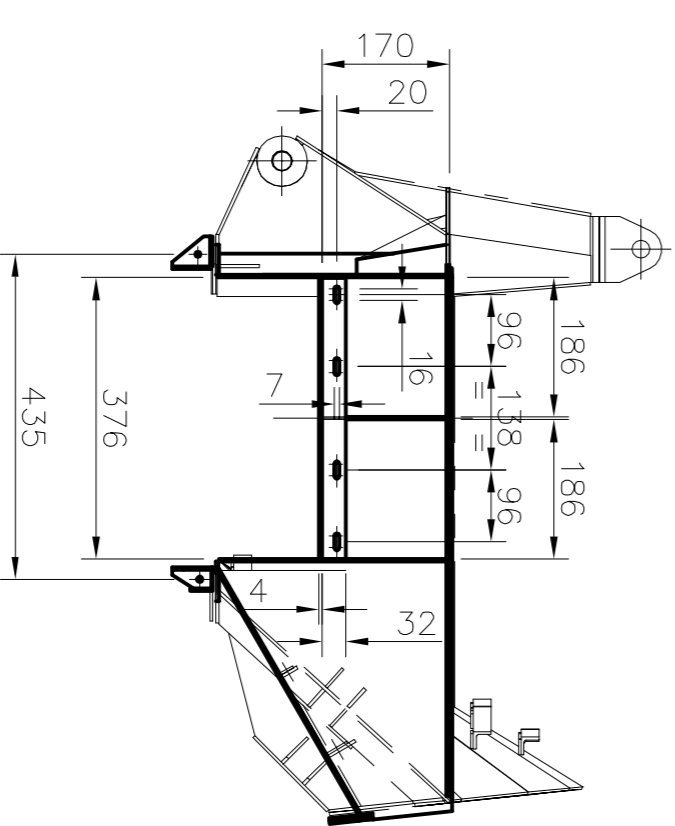
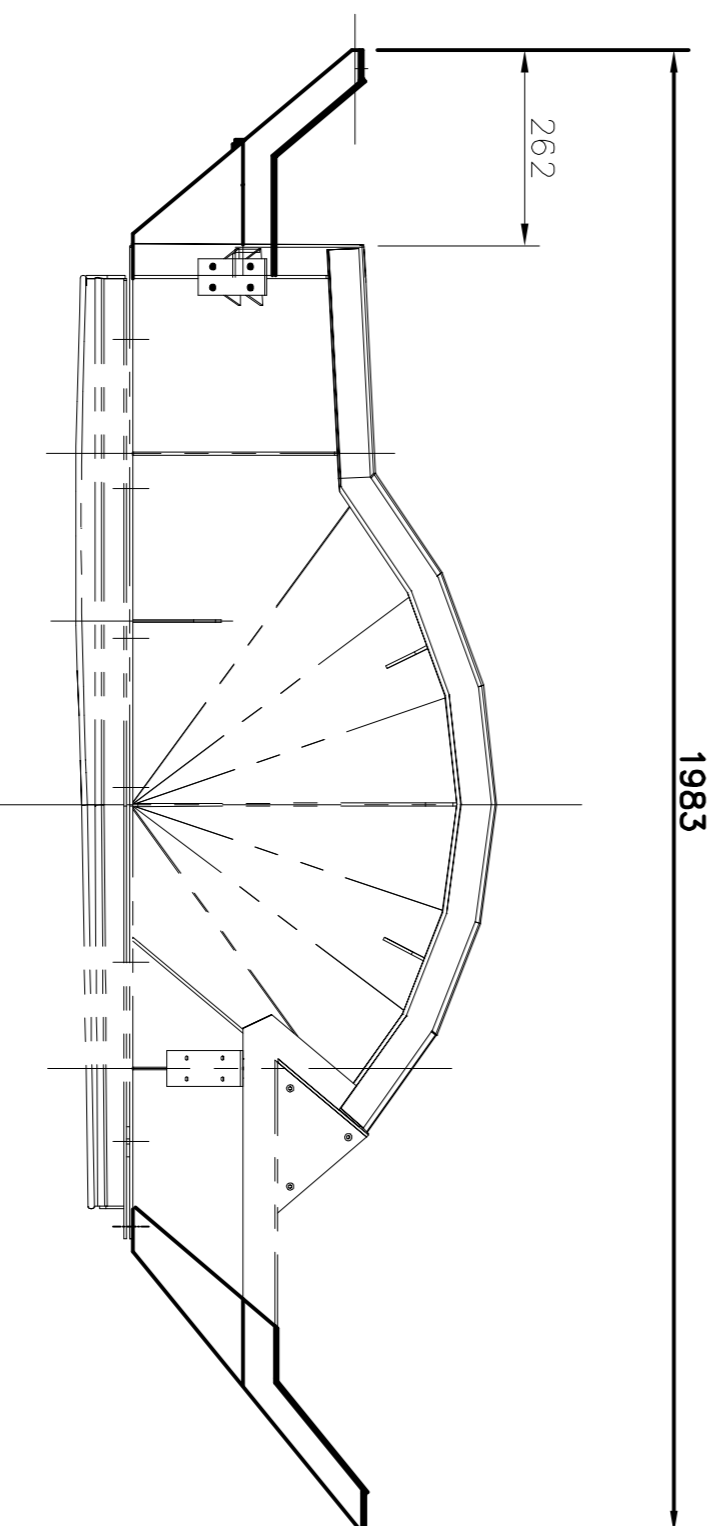
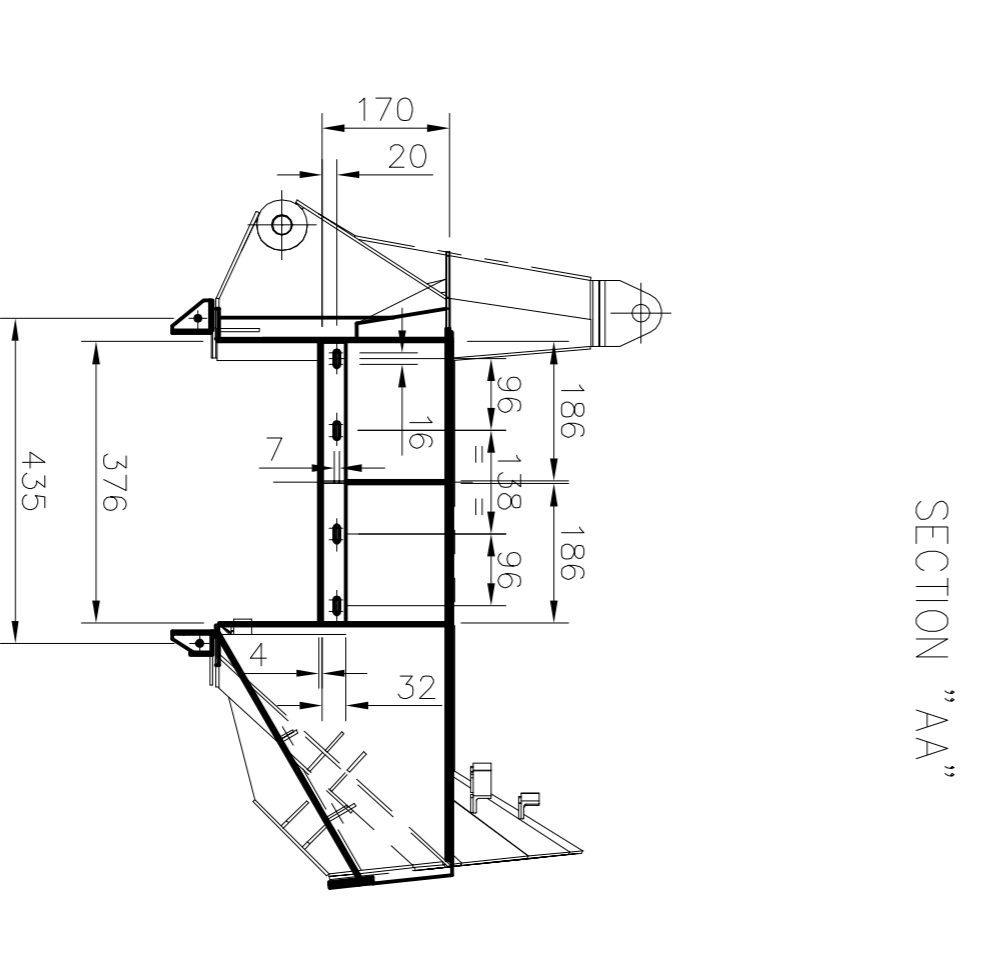
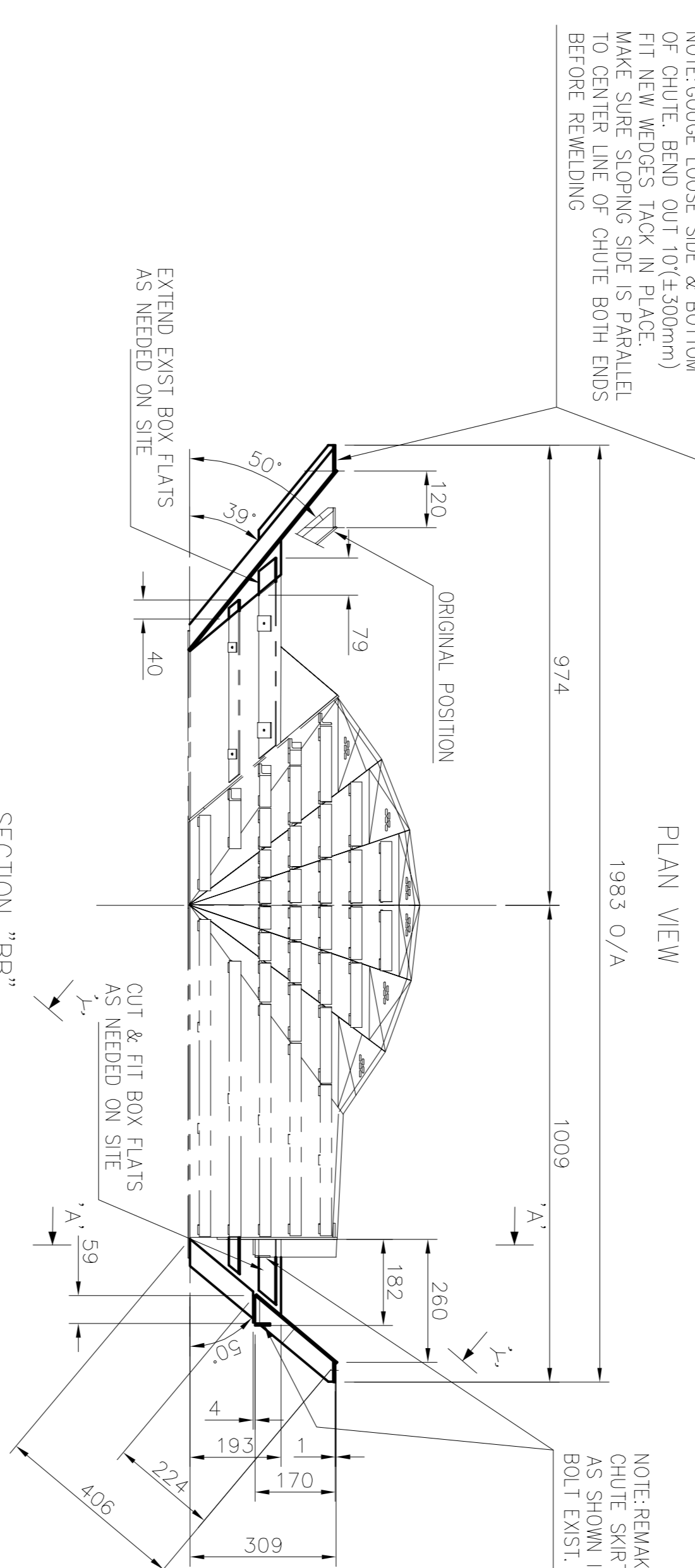
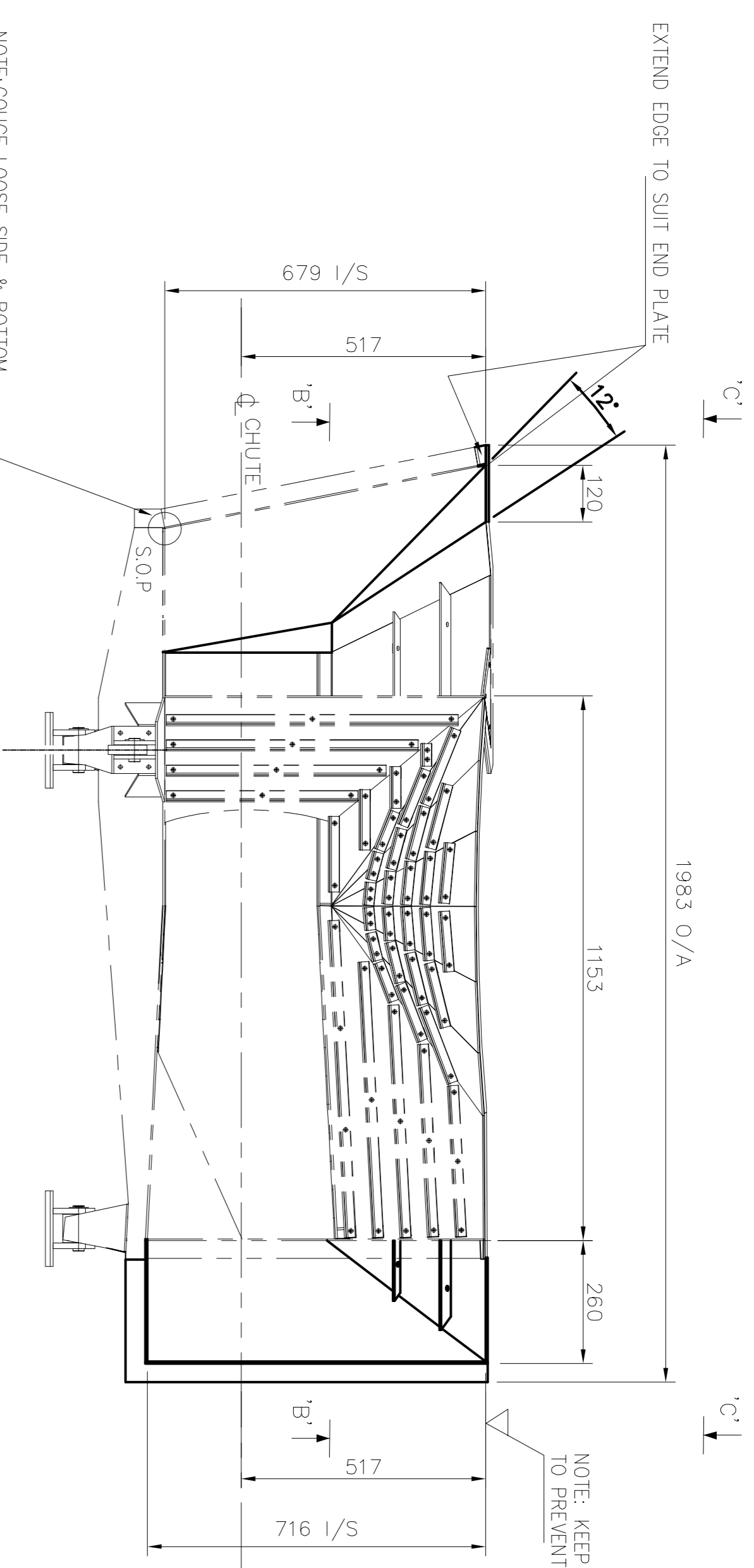

ISSUES RAISED GEN. UPDATE ADD SHEETS 7 & 8. MOD. TO CONTROL SPILLAGE BETWEEN CHUTE & BUCKET WHEEL AS BUILT

ADD NEW SH.6 & 7 EXIST. CHUTE DWG CHANGED TRIALS BEING MONITORED ON PROPOSED MODIFICATIONS.

ISSUED FOR COMMENT

UNLESS OTHERWISE SPECIFIED IDENTIFY THE ITEM WITH THE DRAWING NUMBER AND ISSUE LEVEL AT ▼ AND IN THE MANNER SHOWN FOR PAINTING AND FOR LUBRICATION SPECIFICATIONS SEE COMPONENTS LIST.

UNLESS OTHERWISE STATED DIMENSIONS ARE IN MILLIMETRES TOLERANCES UNLESS OTHERWISE STATED PLUS OR MINUS (I) RANGE MACH FAB CAST

0-500 0.25 2 4

501-1000 0.5 3 6

1001-2000 1.0 6 10

ABOVE 2000 2.0 6 10

This print and all the information herein is the property of Metso Minerals. Bulk Materials Handling Bristol and must not be made public, copied or used in any way detrimental to our interests. It is loaned subject to return on demand unless furnished under contract provisions.

DRAWN	CHECKED	APPROVED	DRAWN	CHECKED	APPROVED	DRAWN	CHECKED	APPROVED	DRAWN	CHECKED	APPROVED	DRAWN	CHECKED	APPROVED	DRAWN	CHECKED	APPROVED
DATE	DATE	DATE	DATE	DATE	DATE	DATE	DATE	DATE	DATE	DATE	DATE	DATE	DATE	DATE	DATE	DATE	DATE

DO NOT SCALE IF IN DOUBT - ASK

metso minerals

SOUTH AFRICAN PORT OPERATIONS
IRON ORE TERMINAL - SALDANHA
STACKER RECLAIMER CONTRACT HQH375
SANCTION No. SB01 D1

METSO MINERALS (UK) LTD
BULK MATERIALS HANDLING BRISTOL
PO BOX 821 ASHTON VALE RD
BRISTOL BS399 5ZB ENGLAND

SALDANHA BAY STACKER RECLAIMER
PROPOSED MODIFICATIONS TO BUCKET
WHEEL CHUTE - ARRANGEMENT

MASS ORIGINAL SCALE
SIZE DRAWING NUMBER
1:25 A1
700457

SHEET 8 OF 8
ISSUE C

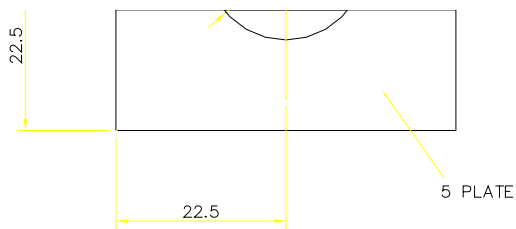

GENERAL NOTES:

1. CHEMICAL & MECHANICAL TEST CERTS. REQUIRED FOR ALL MATERIAL.
2. REMOVE ALL BURRS AND SHARP EDGES.
3. FOR PAINTING & PROTECTION REFER TO MANUFACTURING SPECIFICATION 27496/D15.



△ FIRST ISSUE
AS BUILT

DWB JWH JWH

17 JULY 02 17 JULY 02 17 JULY 02

STEEL
SABS 1431
300 WA (OR EQUIVALENT) SQUARE WASHER

0.1 kg 2:1 700459 1 1 A

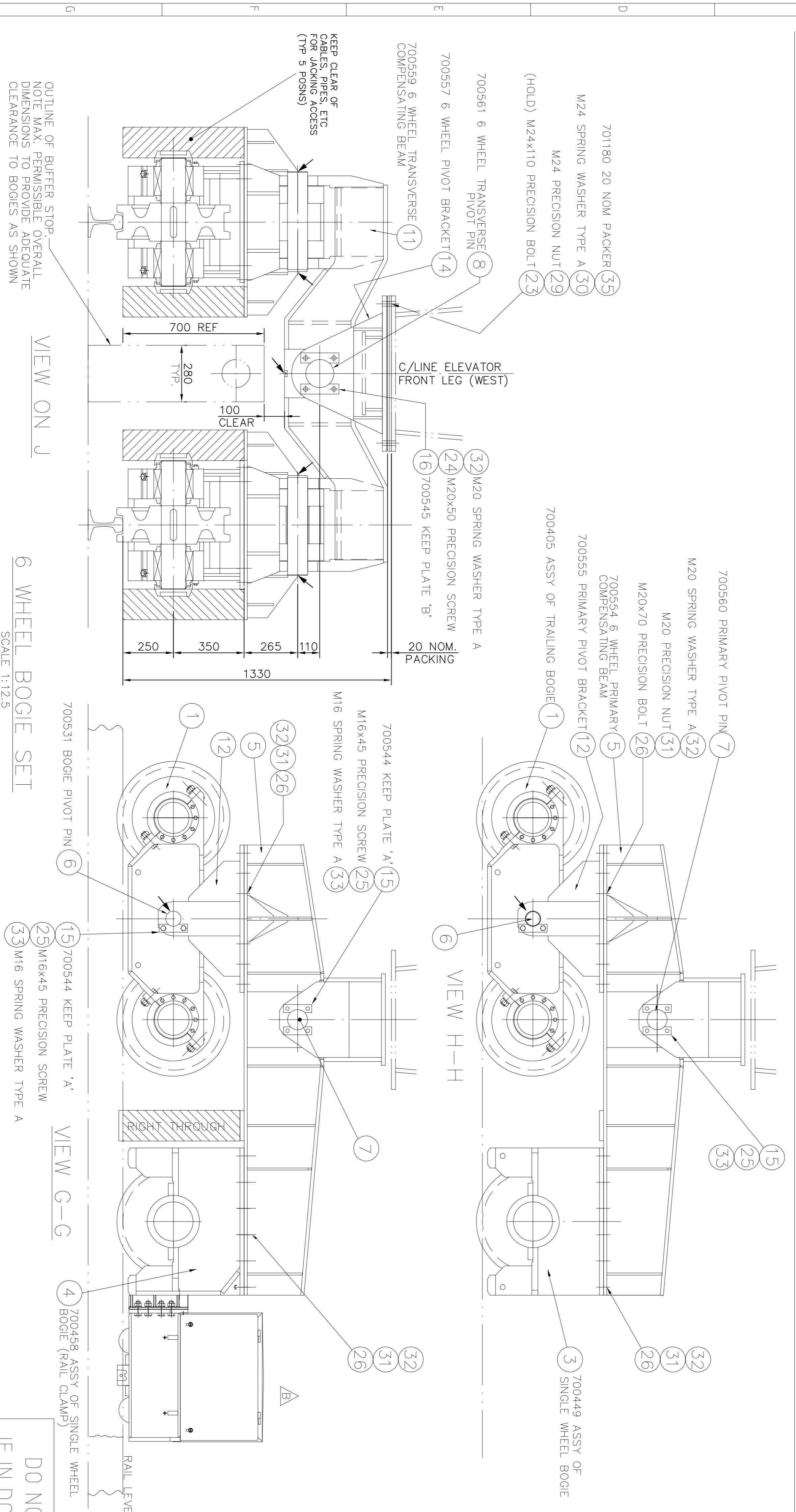
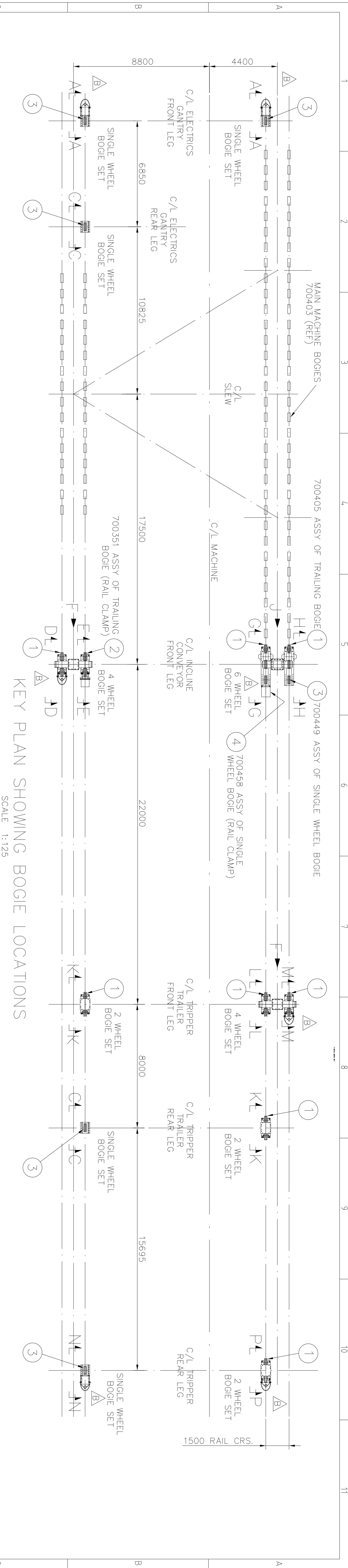

GENERAL NOTES:

- BOGIES TO BE SHOP ASSEMBLED IN ACCORDANCE WITH BOGIE SHOP ASSEMBLY SCHEDULE No 27496/D58.
- NO UNAUTHORISED DRILLINGS OR ATTACHMENTS ARE ALLOWED TO THE TOP & BOTTOM FLANGES OF THE COMPENSATING BEAMS i.e. FOR ATTACHING LUBRICATION PIPES ETC. (CONSULT METSO MINERALS, BRISTOL, UK).
- LUBRICATION:
 - AT POSITIONS SHOWN, THIS INSTALL LUBRICATION FITTINGS (DURING BUILD) SUITABLE FOR FUTURE CONNECTION TO GROUPED SYSTEMS. BLANK OFF EXPOSED ENDS AS REQUIRED. REFER ALSO TO 27496/D42, SPECIFICATION FOR GREASE LUBRICATION.

DO NOT SCALE
IF IN DOUBT - ASK

UNLESS OTHERWISE SPECIFIED IDENTIFY THE ITEM WITH THE DRAWING NUMBER AND ISSUE LEVEL AT AND IN THE MANNER SHOWN FOR PAINTING AND FOR LUBRICATION SPECIFICATIONS SEE COMPONENTS LIST.

UNLESS OTHERWISE STATED DIMENSIONS ARE IN MILLIMETRES TOLERANCES UNLESS OTHERWISE STATED (PLUS OR MINUS) RANGE MACH FAB CAST

0-500	0.5	3	4	6
501-1000	0.5	3	4	6
1001-2000	1.0	4	6	10
ABOVE 2000	2.0	6	10	15

THIS PRINT AND ALL THE INFORMATION HEREON IS THE PROPERTY OF METSO MINERALS. BULK MATERIALS HANDLING GROUP. IT IS LOANED SUBJECT TO RETURN ON DEMAND UNLESS FURNISHED UNDER CONTRACT PROVISIONS.

DO NOT SCALE
IF IN DOUBT - ASK

metso minerals

SALDANHA BAY STACKER RECLAIMER ASSY BOGIES & EQUALISING BEAMS (TOWED EQUIPMENT)

METSO MINERALS (UK) LTD
BULK MATERIALS HANDLING GROUP
PO BOX 821 ASHTON VALE RD
BRISTOL BS99 5ZB ENGLAND

SOUTH AFRICAN PORT OPERATIONS
IRON ORE TERMINAL - SALDANHA
STACKER RECLAIMER CONTRACT HQH375
SANCTION No. SB01D1

MASS 21346kg
ORIGINAL SCALE 1:125, UOS
SIZE DRAWING NUMBER
A1 700460

SHEET OF 1
ISSUE 3
C

DATE	CHECKED	DATE	APPROVED	DATE	CHECKED	DATE	APPROVED	DATE	CHECKED	DATE	APPROVED	DATE	CHECKED	DATE	APPROVED
18.04.06	DDB	22.6.06	HD	22.6.06	JWH	28.04.02	DWB	11.04.02	JWH	12.04.02	JWH	13.06.2002	USB	13.06.2002	JWH
ISSUES RAISED GEN. UPDATE AS BUILT															
SAFETY FENDERS ADDED. RAIL CLAMPS CHANGED. LUBR FITTING NOTE ADDED.															
FIRST ISSUE															
UNLESS OTHERWISE SPECIFIED IDENTIFY THE ITEM WITH THE DRAWING NUMBER AND ISSUE LEVEL AT AND IN THE MANNER SHOWN FOR PAINTING AND FOR LUBRICATION SPECIFICATIONS SEE COMPONENTS LIST.															
UNLESS OTHERWISE STATED DIMENSIONS ARE IN MILLIMETRES TOLERANCES UNLESS OTHERWISE STATED (PLUS OR MINUS) RANGE MACH FAB CAST															
THIS PRINT AND ALL THE INFORMATION HEREON IS THE PROPERTY OF METSO MINERALS. BULK MATERIALS HANDLING GROUP. IT IS LOANED SUBJECT TO RETURN ON DEMAND UNLESS FURNISHED UNDER CONTRACT PROVISIONS.															
DO NOT SCALE IF IN DOUBT - ASK															
metso minerals															
SALDANHA BAY STACKER RECLAIMER ASSY BOGIES & EQUALISING BEAMS (TOWED EQUIPMENT)															
METSO MINERALS (UK) LTD BULK MATERIALS HANDLING GROUP PO BOX 821 ASHTON VALE RD BRISTOL BS99 5ZB ENGLAND															
SOUTH AFRICAN PORT OPERATIONS IRON ORE TERMINAL - SALDANHA STACKER RECLAIMER CONTRACT HQH375 SANCTION No. SB01D1															
MASS 21346kg ORIGINAL SCALE 1:125, UOS SIZE DRAWING NUMBER A1 700460															
SHEET OF 1 ISSUE 3 C															

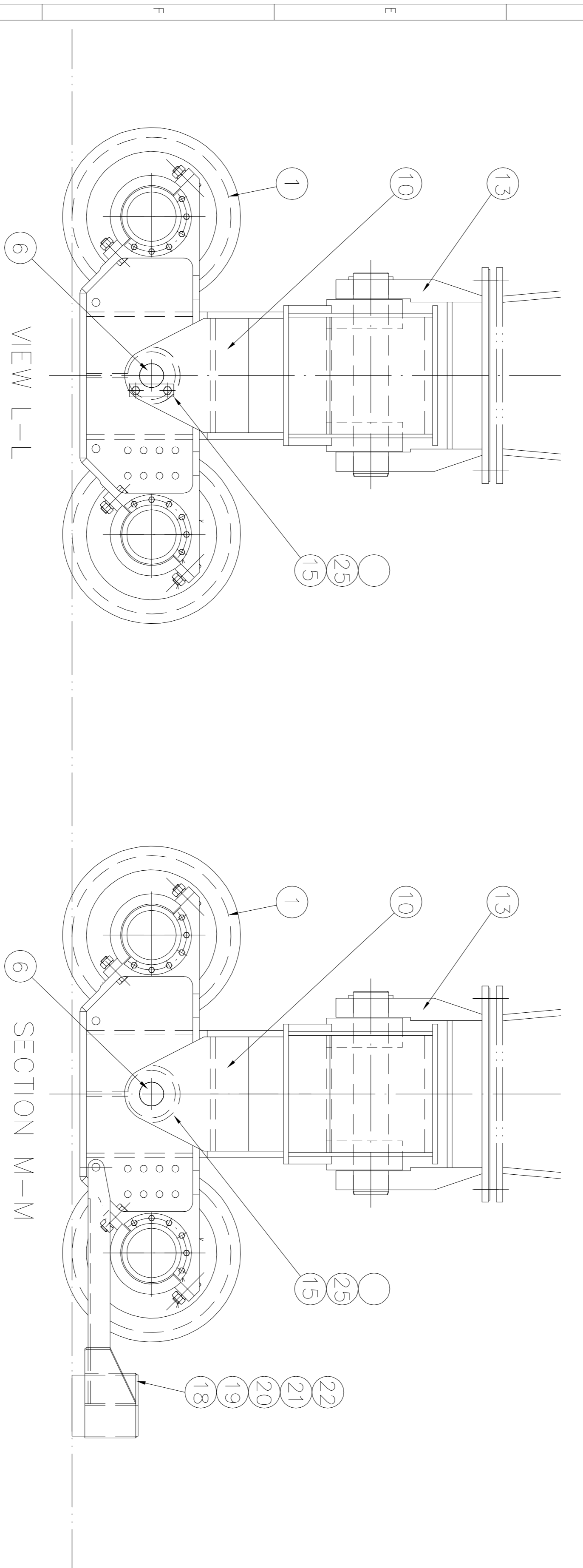
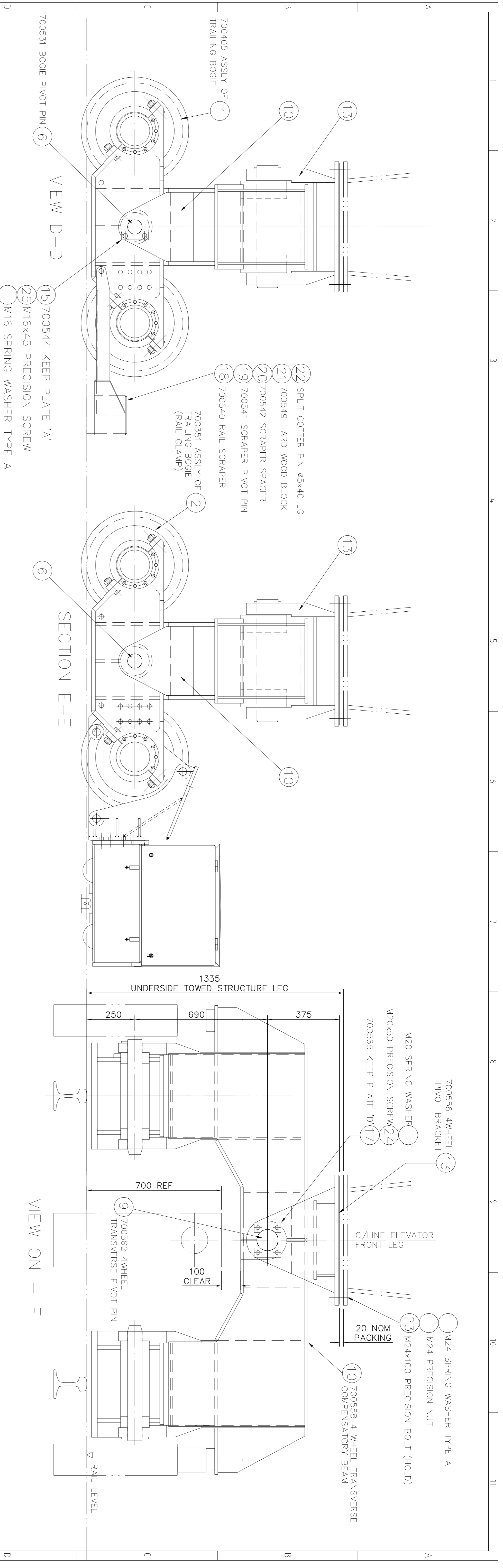

4 WHEEL BOGIE SET

ISSUES RAISED GEN.UPDATE AS BUILT	SAFETY FEEDERS ADDED TO RAIL SCRAPERS, RAIL CLAMP & FIXINGS CHANGED PICTORIALLT.	FIRST ISSUE																																										
<table border="1"> <tr><th>DRAWN</th><th>CHECKED</th><th>APPROVED</th><th>DATE</th></tr> <tr><td></td><td></td><td></td><td></td></tr> </table>	DRAWN	CHECKED	APPROVED	DATE					<table border="1"> <tr><th>DRAWN</th><th>CHECKED</th><th>APPROVED</th><th>DATE</th></tr> <tr><td></td><td></td><td></td><td></td></tr> </table>	DRAWN	CHECKED	APPROVED	DATE					<table border="1"> <tr><th>DRAWN</th><th>CHECKED</th><th>APPROVED</th><th>DATE</th></tr> <tr><td></td><td></td><td></td><td></td></tr> </table>	DRAWN	CHECKED	APPROVED	DATE																						
DRAWN	CHECKED	APPROVED	DATE																																									
DRAWN	CHECKED	APPROVED	DATE																																									
DRAWN	CHECKED	APPROVED	DATE																																									
<table border="1"> <tr><th>DATE</th><th>DATE</th><th>DATE</th><th>DATE</th></tr> <tr><td></td><td></td><td></td><td></td></tr> </table>	DATE	DATE	DATE	DATE					<table border="1"> <tr><th>DATE</th><th>DATE</th><th>DATE</th><th>DATE</th></tr> <tr><td></td><td></td><td></td><td></td></tr> </table>	DATE	DATE	DATE	DATE					<table border="1"> <tr><th>DATE</th><th>DATE</th><th>DATE</th><th>DATE</th></tr> <tr><td></td><td></td><td></td><td></td></tr> </table>	DATE	DATE	DATE	DATE																						
DATE	DATE	DATE	DATE																																									
DATE	DATE	DATE	DATE																																									
DATE	DATE	DATE	DATE																																									
<table border="1"> <tr><th>DATE</th><th>DATE</th><th>DATE</th><th>DATE</th></tr> <tr><td></td><td></td><td></td><td></td></tr> </table>	DATE	DATE	DATE	DATE					<table border="1"> <tr><th>DATE</th><th>DATE</th><th>DATE</th><th>DATE</th></tr> <tr><td></td><td></td><td></td><td></td></tr> </table>	DATE	DATE	DATE	DATE					<table border="1"> <tr><th>DATE</th><th>DATE</th><th>DATE</th><th>DATE</th></tr> <tr><td></td><td></td><td></td><td></td></tr> </table>	DATE	DATE	DATE	DATE																						
DATE	DATE	DATE	DATE																																									
DATE	DATE	DATE	DATE																																									
DATE	DATE	DATE	DATE																																									
DRAWN: DDB, DATE: 18.04.06	CHECKED: HD, DATE: 22.6.06	APPROVED: JWH, DATE: 22.6.06	DRAWN: BLS, DATE: 28.04.02	CHECKED: DVB, DATE: 11.04.02	APPROVED: JWH, DATE: 12.04.02	DRAWN: USB, DATE: 13/06/2002	CHECKED: NCN, DATE: 13/06/2002	APPROVED: JWH, DATE: 10/7/02																																				
<p>UNLESS OTHERWISE SPECIFIED IDENTIFY THE ITEM WITH THE DRAWING NUMBER AND ISSUE LEVEL AT THE END IN THE MANNER SHOWN FOR PAINTING AND FOR LUBRICATION SPECIFICATIONS SEE COMPONENTS LIST.</p> <p>TOLERANCES UNLESS OTHERWISE STATED (PLUS OR MINUS) ARE IN MILLIMETRES</p> <table border="1"> <tr><th>RANGE</th><th>MACH</th><th>FAB</th><th>CAST</th></tr> <tr><td>0-500</td><td>0.25</td><td>2</td><td>4</td></tr> <tr><td>501-1000</td><td>0.5</td><td>3</td><td>6</td></tr> <tr><td>1001-2000</td><td>1.0</td><td>4</td><td>10</td></tr> <tr><td>ABOVE 2000</td><td>2.0</td><td>6</td><td>10</td></tr> </table> <p>This print and all the information herein is the property of Metso Minerals. Bulk Materials Handling Division and must not be made public, copied or used in any way detrimental to our interest. It is loaned subject to return on demand unless furnished under contract provisions.</p>			RANGE	MACH	FAB	CAST	0-500	0.25	2	4	501-1000	0.5	3	6	1001-2000	1.0	4	10	ABOVE 2000	2.0	6	10	<p>UNLESS OTHERWISE SPECIFIED IDENTIFY THE ITEM WITH THE DRAWING NUMBER AND ISSUE LEVEL AT THE END IN THE MANNER SHOWN FOR PAINTING AND FOR LUBRICATION SPECIFICATIONS SEE COMPONENTS LIST.</p> <p>TOLERANCES UNLESS OTHERWISE STATED (PLUS OR MINUS) ARE IN MILLIMETRES</p> <table border="1"> <tr><th>RANGE</th><th>MACH</th><th>FAB</th><th>CAST</th></tr> <tr><td>0-500</td><td>0.25</td><td>2</td><td>4</td></tr> <tr><td>501-1000</td><td>0.5</td><td>3</td><td>6</td></tr> <tr><td>1001-2000</td><td>1.0</td><td>4</td><td>10</td></tr> <tr><td>ABOVE 2000</td><td>2.0</td><td>6</td><td>10</td></tr> </table> <p>This print and all the information herein is the property of Metso Minerals. Bulk Materials Handling Division and must not be made public, copied or used in any way detrimental to our interest. It is loaned subject to return on demand unless furnished under contract provisions.</p>		RANGE	MACH	FAB	CAST	0-500	0.25	2	4	501-1000	0.5	3	6	1001-2000	1.0	4	10	ABOVE 2000	2.0	6	10
RANGE	MACH	FAB	CAST																																									
0-500	0.25	2	4																																									
501-1000	0.5	3	6																																									
1001-2000	1.0	4	10																																									
ABOVE 2000	2.0	6	10																																									
RANGE	MACH	FAB	CAST																																									
0-500	0.25	2	4																																									
501-1000	0.5	3	6																																									
1001-2000	1.0	4	10																																									
ABOVE 2000	2.0	6	10																																									
<p>DO NOT SCALE</p> <p>IF IN DOUBT - ASK</p>			<p>THIRD ANGLE</p>		<p>SEE SHEET 1 ORIGINAL SCALE 1:10 SIZE DRAWING NUMBER A1 700460</p>																																							
<p>SOUTH AFRICAN PORT OPERATIONS IRON ORE TERMINAL - SALDANHA STACKER RECLAIMER CONTRACT HQH375 SANCTION No. SB01D1</p>			<p>metso minerals</p>		<p>TITLE: SALDANHA BAY STACKER RECLAIMER ASSY BOGIES & EQUALISING BEAMS (TOWED EQUIPMENT)</p>																																							
<p>BUK MATERIALS HANDLING BRISTOL PO BOX 821 ASHTON VALE RD BRISTOL BS99 5ZB ENGLAND</p>			<p>metso minerals</p>		<p>SHEET 2 OF 3 ISSUE C</p>																																							

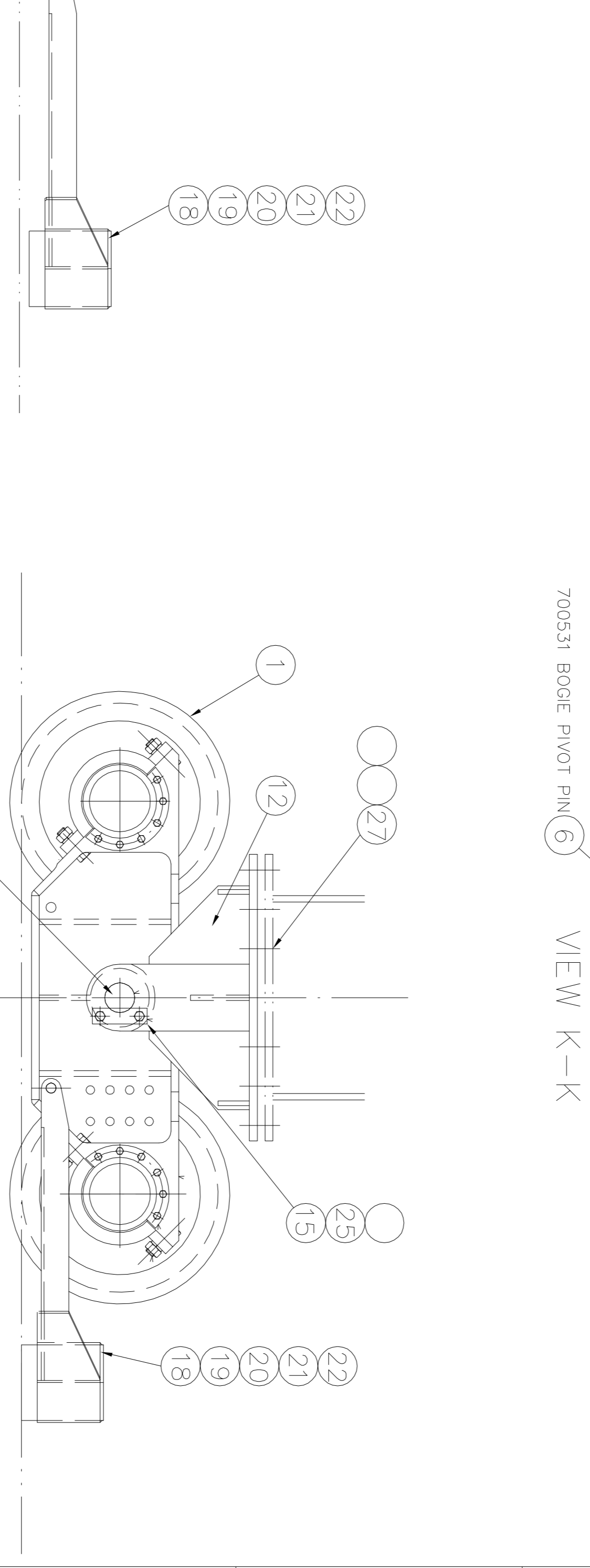
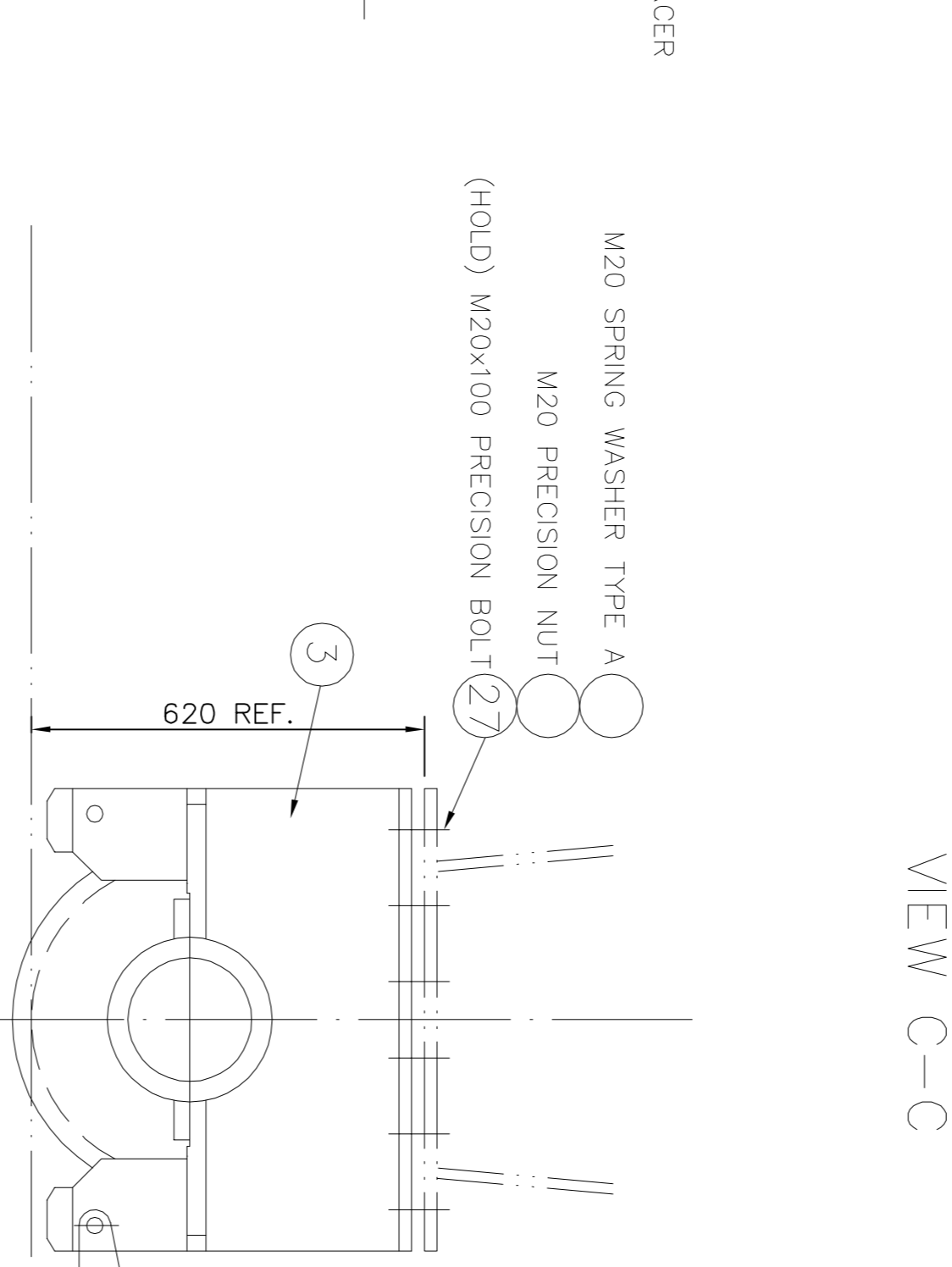
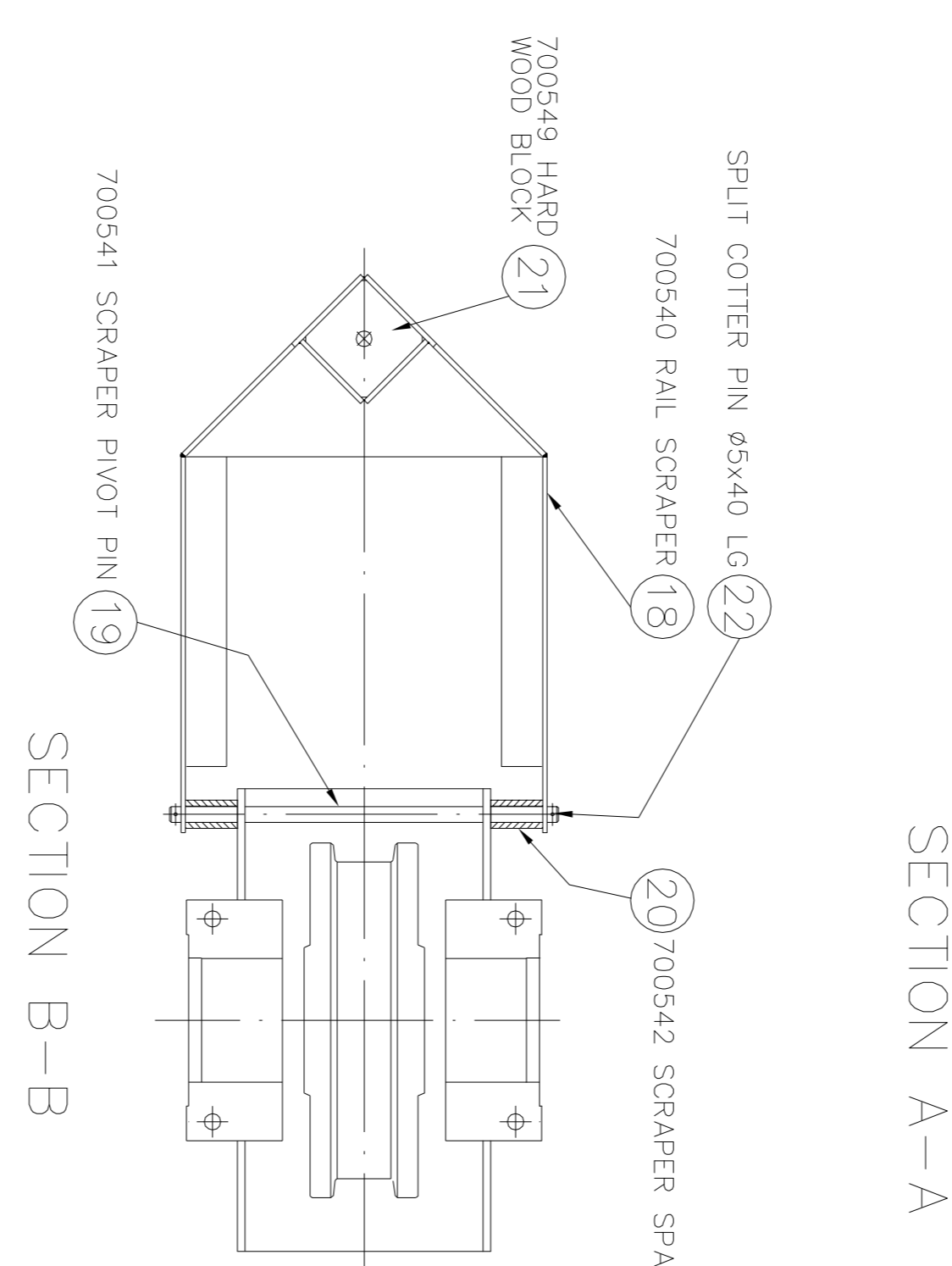
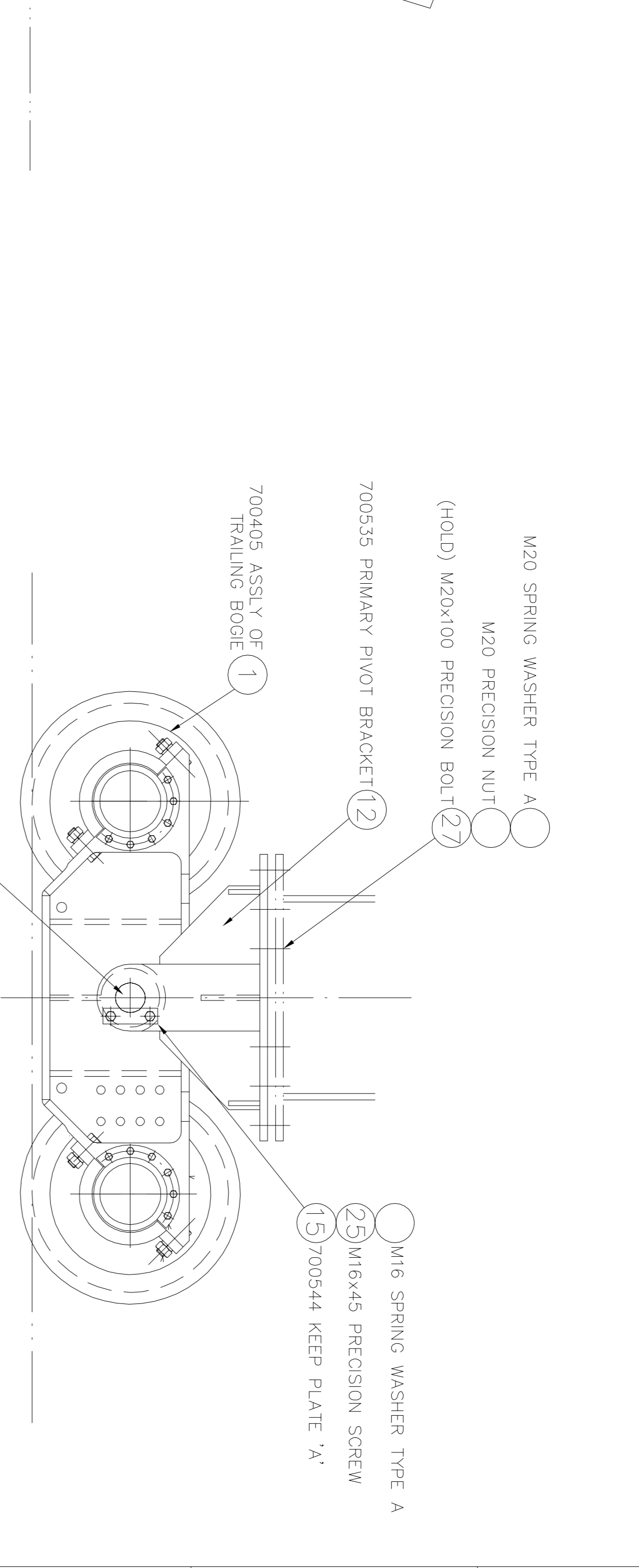
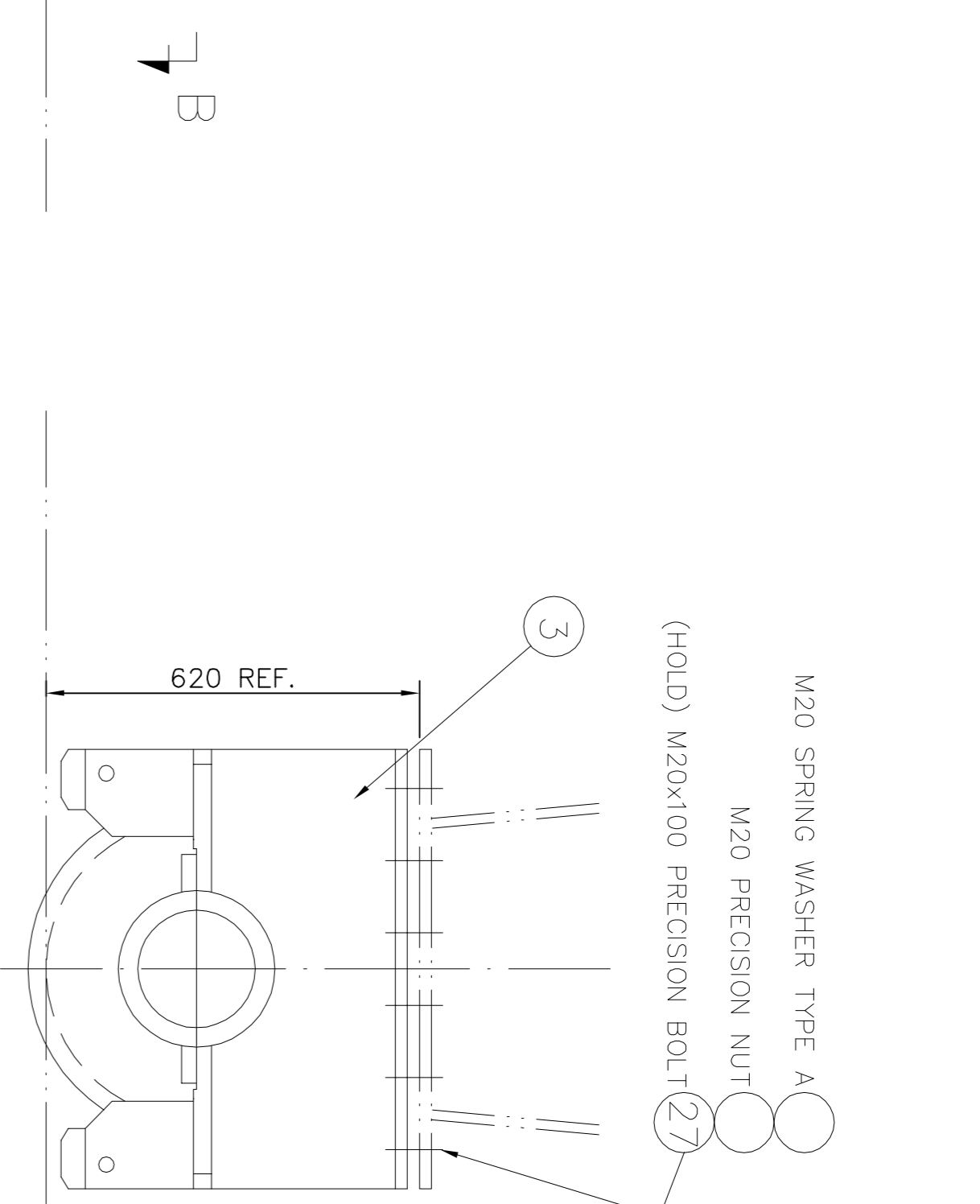
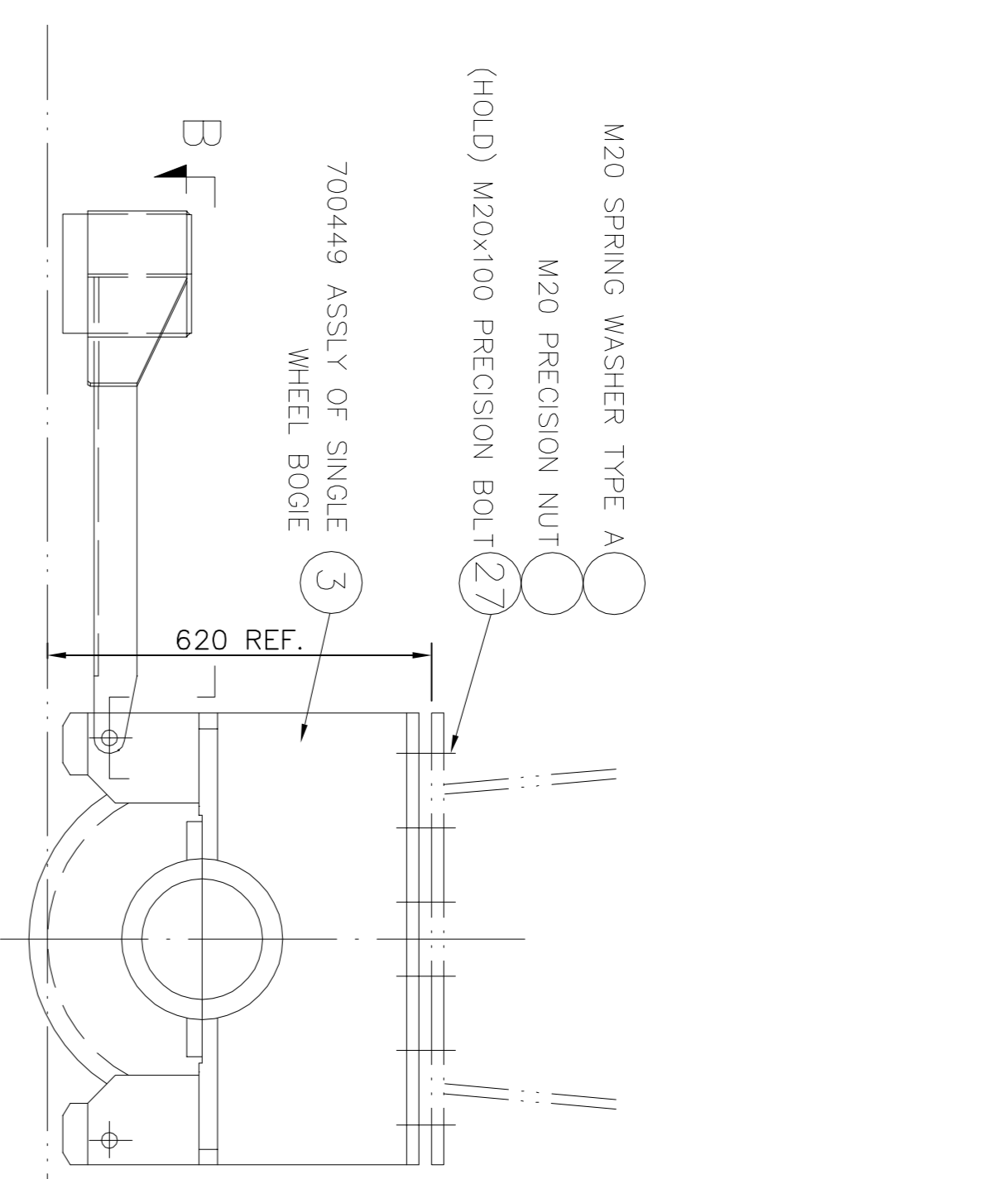

SINGLE WHEEL BOGIE SET

2 WHEEL BOGIE SET

DATE	APPROVED	DATE	APPROVED	DATE	APPROVED	DATE	APPROVED	DATE	APPROVED	DATE	APPROVED
18.04.06	DDB	22.6.06	HD	22.6.06	JWH	28 OCT 02	BLS	11 NOV 02	DVB	12 NOV 02	JWH
ISSUES RAISED GEN.UPDATE AS BUILT		SAFETY FENDERS. ADDED TO RAIL SCRAPER.		FIRST ISSUE		UNLESS OTHERWISE SPECIFIED IDENTIFY THE ITEM WITH THE DRAWING NUMBER AND ISSUE LEVEL AT AND IN THE MANNER SHOWN FOR PAINTING AND FOR LUBRICATION SPECIFICATIONS SEE COMPONENTS LIST.					
TOLERANCES UNLESS STATED DIMENSIONS ARE IN MILLIMETRES		RANGE		MACH		FAB		CAST		UNLESS OTHERWISE STATED DIMENSIONS ARE IN MILLIMETRES	
0-500		0.5		2		3		4		UNLESS OTHERWISE STATED DIMENSIONS ARE IN MILLIMETRES	
501-1000		0.25		2		3		4		UNLESS OTHERWISE STATED DIMENSIONS ARE IN MILLIMETRES	
1001-2000		0.1		2		3		4		UNLESS OTHERWISE STATED DIMENSIONS ARE IN MILLIMETRES	
ABOVE 2000		2.0		2.0		2.0		2.0		UNLESS OTHERWISE STATED DIMENSIONS ARE IN MILLIMETRES	

DO NOT SCALE
IF IN DOUBT - ASK

metso minerals

SOUTH AFRICAN PORT OPERATIONS
IRON ORE TERMINAL - SALDANHA
STACKER RECLAIMER CONTRACT HQH375
SANCTION No. SB01 D1

METSO MINERALS (UK) LTD
BULK MATERIALS HANDLING BRISTOL
PO BOX 821 ASHTON VALE RD
BRISTOL BS99 5ZB ENGLAND

TITLE: SALDANHA BAY STACKER RECLAIMER ASSY BOGIES & EQUALISING BEAMS (TOWED EQUIPMENT)

MASS: SEE SHEET 1 ORIGINAL SCALE: 1:10 SIZE: DRAWING NUMBER: A1 700460 SHEET OF: 3 ISSUE: 3 C

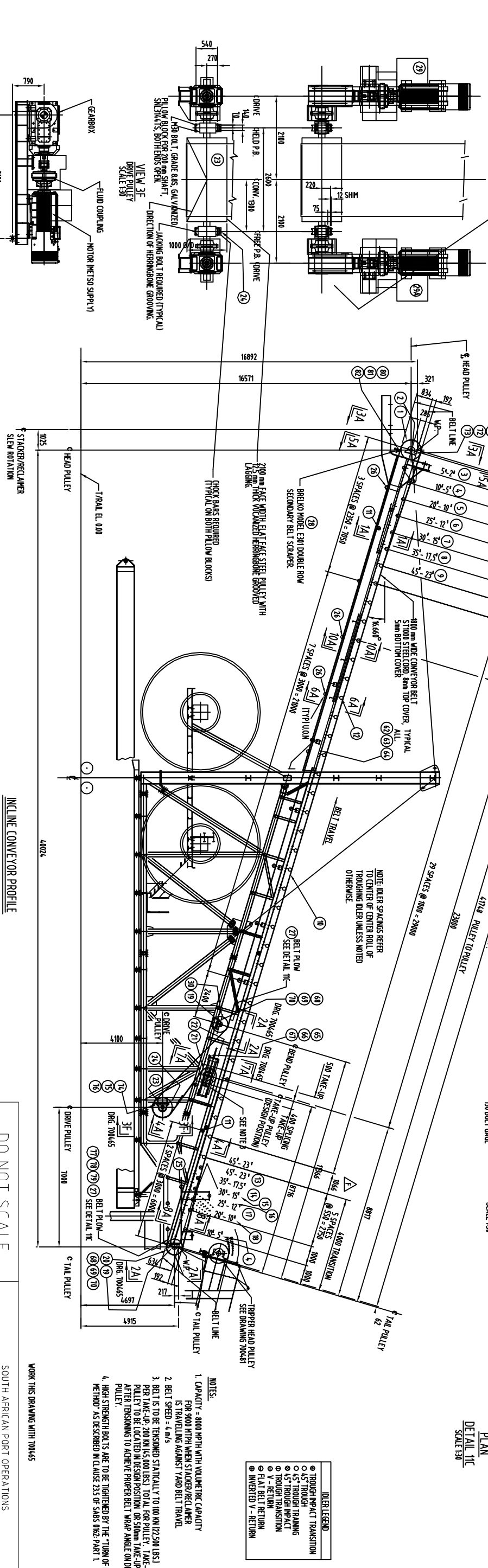
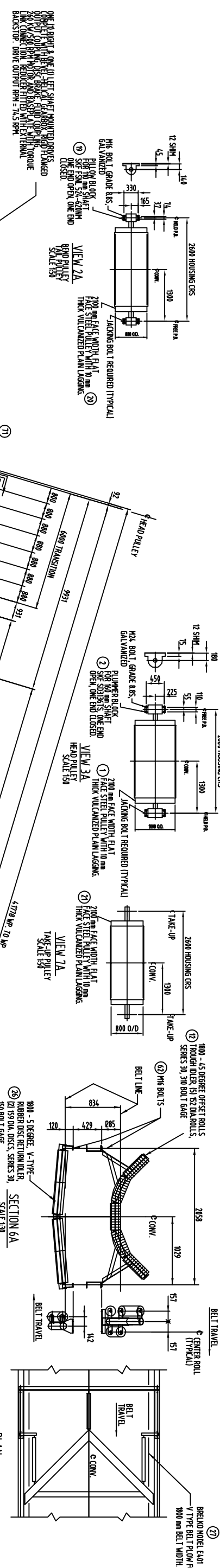
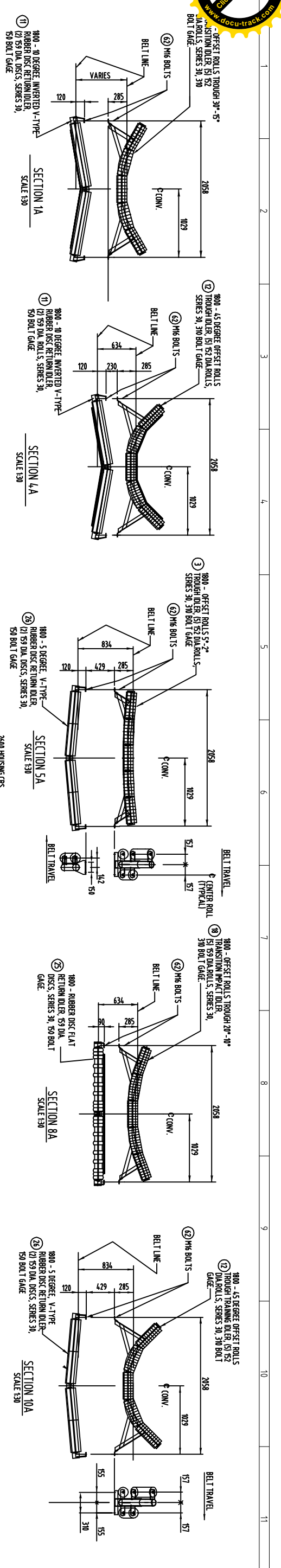

ISSUES RAISED GENERAL UPDATE AS BUILT

REVISOR TO SUIT IDLER BRTS. SHEET 3 ADDED

UPDATED TO SUIT COMMENTS

UPDATED AS PER LATEST D.S.O

DO NOT SCALE
IF IN DOUBT - ASK

metso
minerals

SALDANHA BAY STACKER/RECLAIMER.
IRON ORE TERMINAL - SALDANHA
STACKER RECLAIMER CONTRACT H0H375
SANCTION NO. SB011 D1

WORK THIS DRAWING WITH 700465

UNLESS OTHERWISE SPECIFIED DENOTE THE ITEM WITH THE DRAWING NUMBER AND SIZE LEVEL AT Φ AND IN THE MANNER SHOWN FOR PAINTING AND FOR LUBRICATION SPECIFICATIONS SEE COMPONENTS LIST

UNLESS OTHERWISE STATED DIMENSIONS ARE IN MILLIMETERS
DIMENSIONS IN PARENTHESIS ARE IN INCHES

GRADE	1	2	3	4	5	6	7	8	9	10	11
GRADE	0.500	0.25	2	3	4	6	6	6	6	6	10
GRADE	501-1000	1001-2000	2001-3000	3001-4000	4001-5000	5001-6000	6001-7000	7001-8000	8001-9000	9001-10000	ABOVE 2000
GRADE	0.500	0.25	2	3	4	6	6	6	6	6	10

- IDLER LEGEND**
- THROUGH IMPACT TRANSITION
 - 45° THROUGH TRANSITION
 - 45° THROUGH IMPACT
 - THROUGH TRANSITION
 - THROUGH IMPACT
 - FLAT BELT RETURN
 - INVERTED V-TYPE RETURN

- NOTES:**
1. CAPACITY - 8000 MTPH WITH VOLUMETRIC CAPACITY FOR 9000 MTPH WHEN STACKER/RECLAIMER IS TRAVELLING AGAINST YARD BELT TRAVEL
 2. BELT SPEED = 4 m/s
 3. BELT TO BE TENSIONED STATIONARILY TO 100 KN (22,500 LBS) PER TAKE-UP. 200 KN (45,000 LBS) TOTAL FOR PULLEY TAKE-UP PULLEY TO BE LOCATED IN DESIGN POSITION OR 300mm TAKE-UP AREA AFTER TENSIONING TO ACHIEVE PROPER BELT WRAP ANGLE ON DRIVE PULLEY.
 4. HIGH STRENGTH BOLTS ARE TO BE TIGHTENED BY THE "TURN OF NUT METHOD" AS DESCRIBED IN CLAUSE 235 OF SABS 0162 PART 1.

NO.	DATE	APPROVED	DATE	APPROVED	NO.	DATE	APPROVED	DATE	APPROVED	NO.	DATE	APPROVED	DATE	APPROVED	NO.	DATE	APPROVED	DATE	APPROVED
1					2					3					4				
5					6					7					8				
9					10					11									

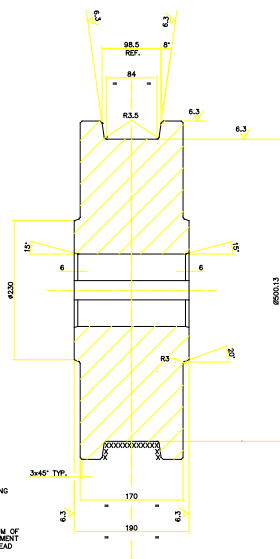
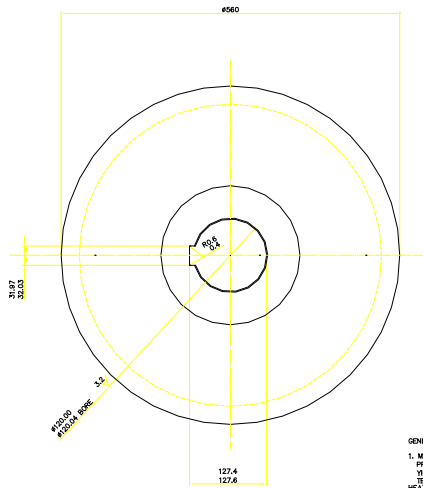

GENERAL NOTES

- MATERIAL STEEL TO ASTM A 504 GRADE C, TO GIVE THE FOLLOWING PROPERTIES:
 YIELD STRENGTH 650 N/mm² MIN
 TENSILE STRENGTH 850 N/mm² MIN
 HEAT TREATED TO PROVIDE TREADS & FLANGES
 (INDICATED THIS XXXXX) UNIFORM HARDENED TO GIVE A MINIMUM OF 325 BHN WITH A MINIMUM PENETRATION OF 10mm. THE HEAT TREATMENT SHALL PROVIDE A UNIFORM TRANSITION OF HARDNESS FROM THE TREAD TO THE SOFTER CORE.
- THE TREAD AREA SHOWN THIS XXXXX TO BE MAGNETIC PARTICLE TESTED TO BS6072. ACCEPTANCE STANDARD FOR LINEAR & ROUNDED INDICATIONS SHALL BE 4.5mm MAX DEFECT SIZE, WITH 1.6mm MIN. SEPARATION FOR 4 OR MORE INDICATIONS IN A LINE. MAX PERMISSIBLE NUMBER OF INDICATIONS IN ANY AREA 2807mm² (150mm MAX MAJOR DIMENSION) SHALL BE 10. CRACKS & DISCRETE INDICATIONS SHALL BE CAUSE FOR REJECTION.
- ALL MATERIAL WITHIN 25 mm OF THE TREAD SURFACE TO BE ULTRASONICALLY TESTED TO BS4124 AFTER FINAL HEAT TREATMENT. TURN CRYSTAL LONGITUDINAL AND TRANSVERSE PROBES TO BE USED. TRANSVERSE PROBES TO BE USED IN TWO DIRECTIONS MUTUALLY AT RIGHT ANGLES. REFERENCE DISCONTINUITY TO BE 3.2 mm DIA.
- OPERATORS TO BE QUALIFIED TO SNT-TO-1A LEVEL 11 OR QUALIFICATION CERTIFICATES TO CSWP.
- REFER ALSO TO COMPONENT INSPECTION PLAN.

**DO NOT SCALE
IF IN DOUBT -**

UNLESS OTHERWISE SPECIFIED INDENTIFY THE TREAD WITH THE QUANTITY NUMBER AND HOLE LEVEL BY AND IN THE MANNER SHOWN FOR PATRONS AND FOR ILLUSTRATION SPECIFICATIONS SEE COMPONENTS

DRAWN BY: [Signature]
 CHECKED BY: [Signature]
 DATE: [Date]
 MATERIAL: STEEL
 FINISH: [Blank]
 NOTES: SEE NOTE

SOUTH AFRICAN PORT
 OPERATIONS
 IRON ORE TERMINAL -
 SALDANHA
 STACKER RECLAIMER HOISTWAY
 THROUGH MATERIALS HANDLING
 metso minerals
 SANCTION NO. 3065-01
 BRISTOL BS99 52B ENGLAND.

BOGIE WHEEL
 MASS: 219 kg
 ORIGINAL SCALE: 1:2.5
 SIZE: A1
 DRAWING NUMBER: 700520
 SHEET OF: 11

DATE	BY	CHKD	APPV	DATE	BY	CHKD	APPV	DATE	BY	CHKD	APPV

DATE	BY	CHKD	APPV	DATE	BY	CHKD	APPV

DATE	BY	CHKD	APPV	DATE	BY	CHKD	APPV

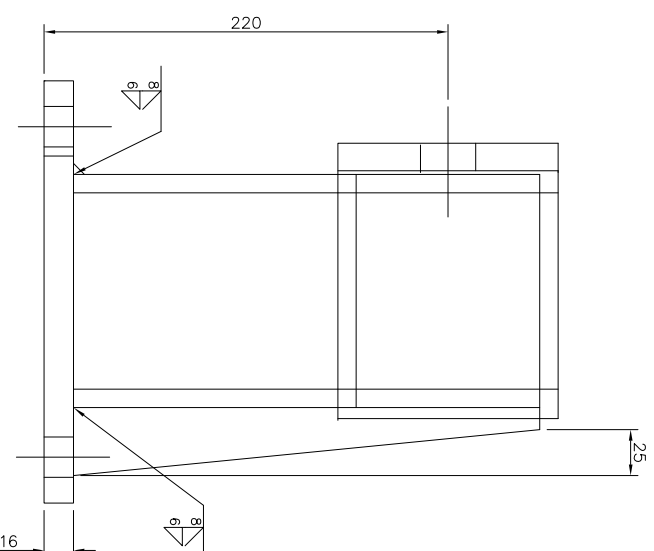
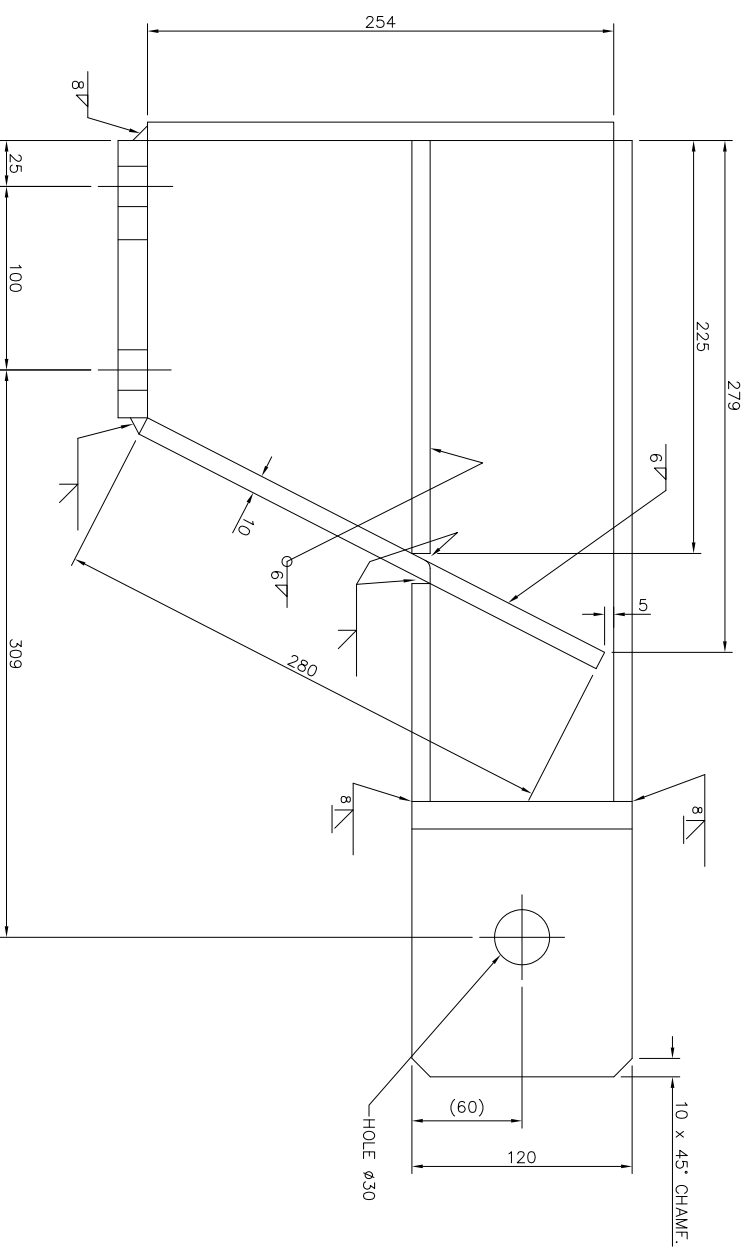
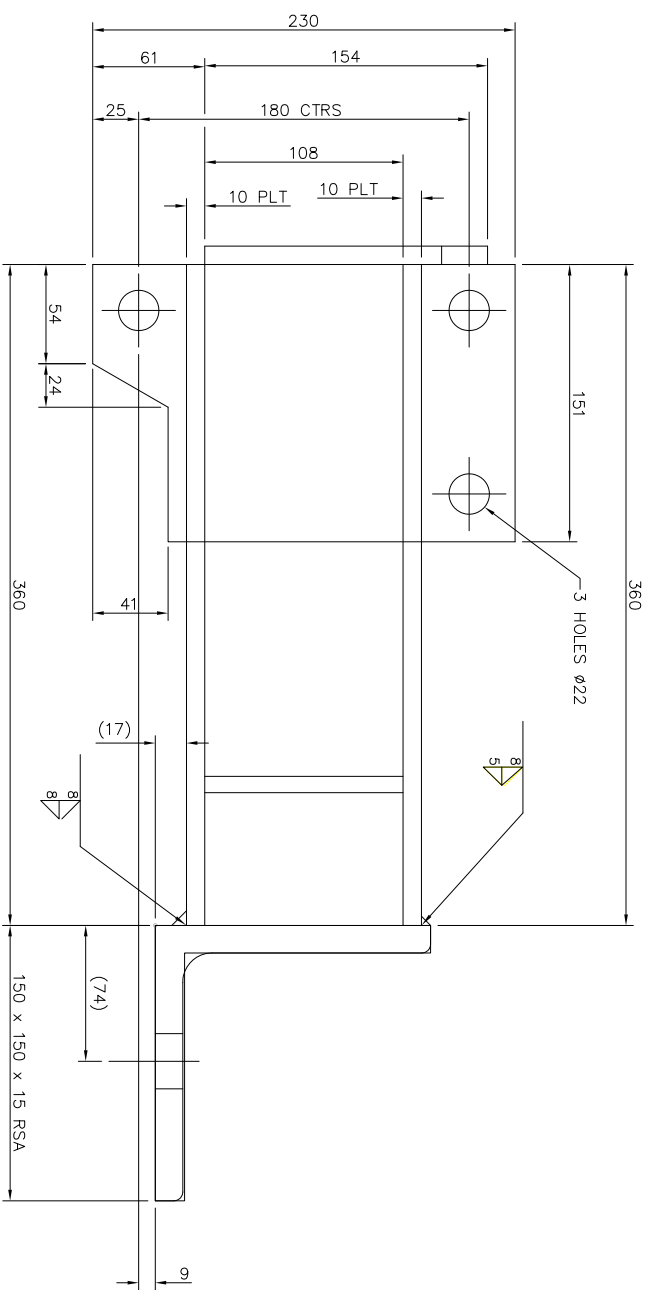

- GENERAL NOTES:
1. MATERIAL - ALL PLATES TO SABS1431 GRADE 300WA.
 2. ALL WELDING TO BE 6mm CONT.FILET (UNLESS OTHERWISE STATED) TO MANUFACTURING SPECIFICATION 27496/D15.
 3. REMOVE ALL BURRS AND SHARP EDGES.
 4. FOR PAINTING & PROTECTION REFER TO MANUFACTURING SPECIFICATION 27496/D15.

FIRST ISSUE
AS BUILT

SEE NOTES ABOVE
SEE NOTES ABOVE

TORQUE ARM BRACKET
(LONG TRAVEL)

CF DMB JMH
15/7/02 17 JULY 02 17 JULY 02

29 kg 1:2

700527

1 1 A

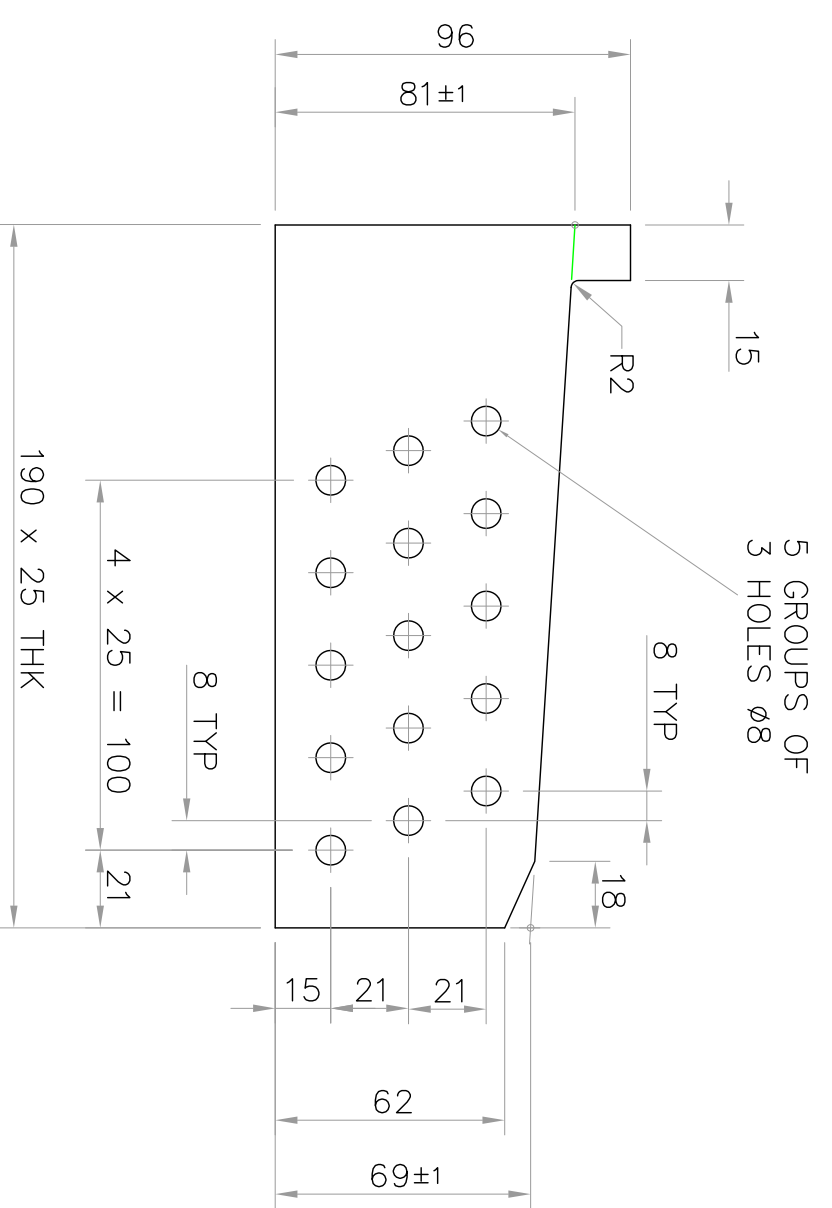

PAINTING & PROTECTION TO MANUFACTURING SPEC 27496/D15.

△ FIRST ISSUE
AS BUILT

DRAWN	CHECKED	APPROVED
GBL	DWB	JWH
DATE	DATE	DATE
7 AUG 02	24/9/02	08/10/02

△

DRAWN	CHECKED	APPROVED
DATE	DATE	DATE

UNLESS OTHERWISE SPECIFIED IDENTIFY THE ITEM WITH THE DRAWING NUMBER AND ISSUE LEVEL AT **△** AND IN THE MANNER SHOWN. FOR PAINTING AND FOR LUBRICATION SPECIFICATIONS SEE COMPONENTS LIST.

UNLESS OTHERWISE STATED DIMENSIONS ARE IN MILLIMETRES. TOLERANCES UNLESS OTHERWISE STATED (PLUS OR MINUS)

RANGE	MACH	FAB	CAST
0-500	0.25	2	2
501-1000	0.5	3	4
1001-2000	1.0	4	6
ABOVE 2000	2.0	6	10

This print and all the information hereon is the property of Metso Minerals, Bulk Materials Handling Bristol and must not be made public, copied or used in any way detrimental to our interest. It is loaned subject to return on demand, unless furnished under contract provisions.

DO NOT SCALE
IF IN DOUBT - ASK



SOUTH AFRICAN PORT OPERATIONS
IRON ORE TERMINAL - SALDANHA
STACKER RECLAIMER CONTRACT HQH375
SANCTION No. SB01 D1



METSO MINERALS (UK Ltd)
BULK MATERIALS HANDLING BRISTOL
PO BOX 821 ASHTON VALE RD
BRISTOL BS99 5ZB ENGLAND.

TITLE
BUCKET LOCKING WEDGE

DRAWN TO BS 8888.	WELD SYMBOLS TO AWS/ANSI 2.4	THIRD ANGLE PROJ.	SIZE	DRAWING NUMBER	SHEET	OF	ISSUE
SURFACE TEXTURE TO BS 1134.	MATERIAL & CONDITION BEFORE MANUFACTURE		A3	701192	1	1	A
MATL. STEEL	NOTES						
SPEC. SABS 1431							
GRADE 300WA							
MASS 3 kg	ORIGINAL SCALE 1:2						

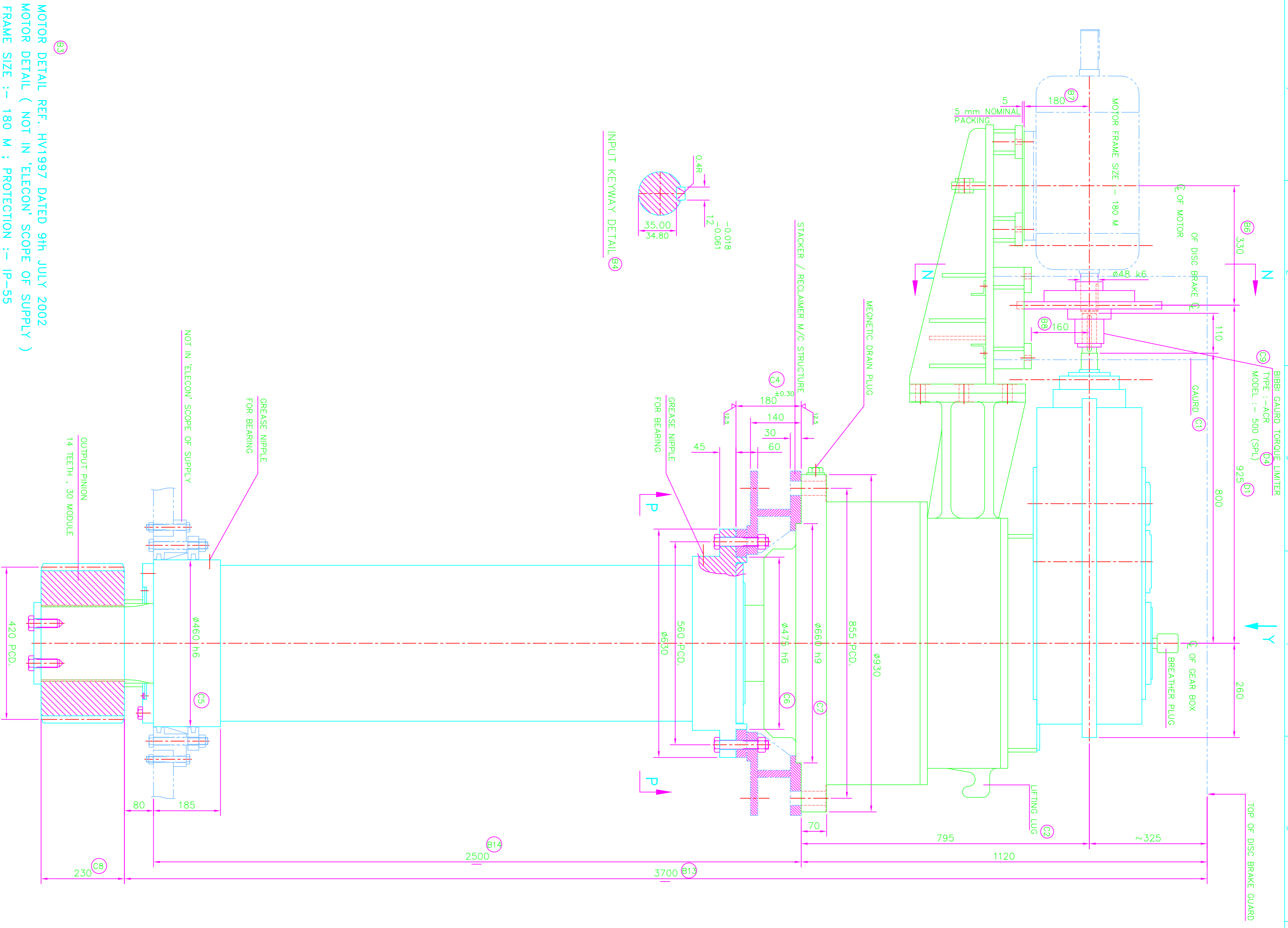

REVISIONS:

REV. NO.	DESCRIPTION
A	ISSUE SIGNATURE
B	ISSUE SIGNATURE
C	ISSUE SIGNATURE
D	ISSUE SIGNATURE
E	ISSUE SIGNATURE
F	ISSUE SIGNATURE
G	ISSUE SIGNATURE
H	ISSUE SIGNATURE

APPROVED: [Signature]

CHECKED: [Signature]

SCALE:

NOTE:

1. MOTOR DETAIL REF. HV1997 DATED 9th JULY 2002

2. MOTOR DETAIL (NOT IN 'ELECON' SCOPE OF SUPPLY)

3. FRAME SIZE :- 180 M ; PROTECTION :- IP-55

4. MAKE :-

5. TYPE :- THREE PHASE INDUCTION MOTOR – SQUIRREL CAGE

6. POWER :- 18.50 KW,

7. SPEED :- 1475 RPM.

DRAMA

REV. NO.	DESCRIPTION
A	ISSUE SIGNATURE
B	ISSUE SIGNATURE
C	ISSUE SIGNATURE
D	ISSUE SIGNATURE
E	ISSUE SIGNATURE
F	ISSUE SIGNATURE
G	ISSUE SIGNATURE
H	ISSUE SIGNATURE

DRAMA

DESIGN

ENGINEERING

THIS DRAWING IS THE PROPERTY OF ELECON ENGINEERING CO. LTD. LOANED TO THE REPERT AND FOR THE USE OF ANOTHER BUT NOT BE REPRODUCED OR USED IN ANY MANNER WITHOUT THE WRITTEN PERMISSION OF ELECON ENGINEERING CO. LTD. FOR THE PURPOSE OF MAINTAINING THE EQUIPMENT TO WHICH IT REFERS.

ORDER NO : Pj-579

7708305/1 E

TOLERANCES UNLESS OTHERWISE STATED ARE IN MILLIMETRES

RANGE	MACH	FAB	CAST
0-500	0.25	2	2
501-1000	0.5	3	4
1001-2000	1.0	4	6
ABOVE 2000	2.0	6	10

DO NOT SCALE

IF IN DOUBT - ASK

metso minerals

SOUTH AFRICAN PORT OPERATIONS

IRON ORE TERMINAL - SILDANHA

STACKER RECLAIMER CONTRACT H0H375

SAANCTION NO. SB01D1

metso minerals

BULK MATERIALS HANDLING BRISTOL

PO BOX 827 ASHTON VALE RD

BRISTOL BS99 5ZB ENGLAND.

MASS kg

ORIGINAL SCALE 1:1

SIZE A1

DRAWING NUMBER 701650

SHEET 1 OF 1

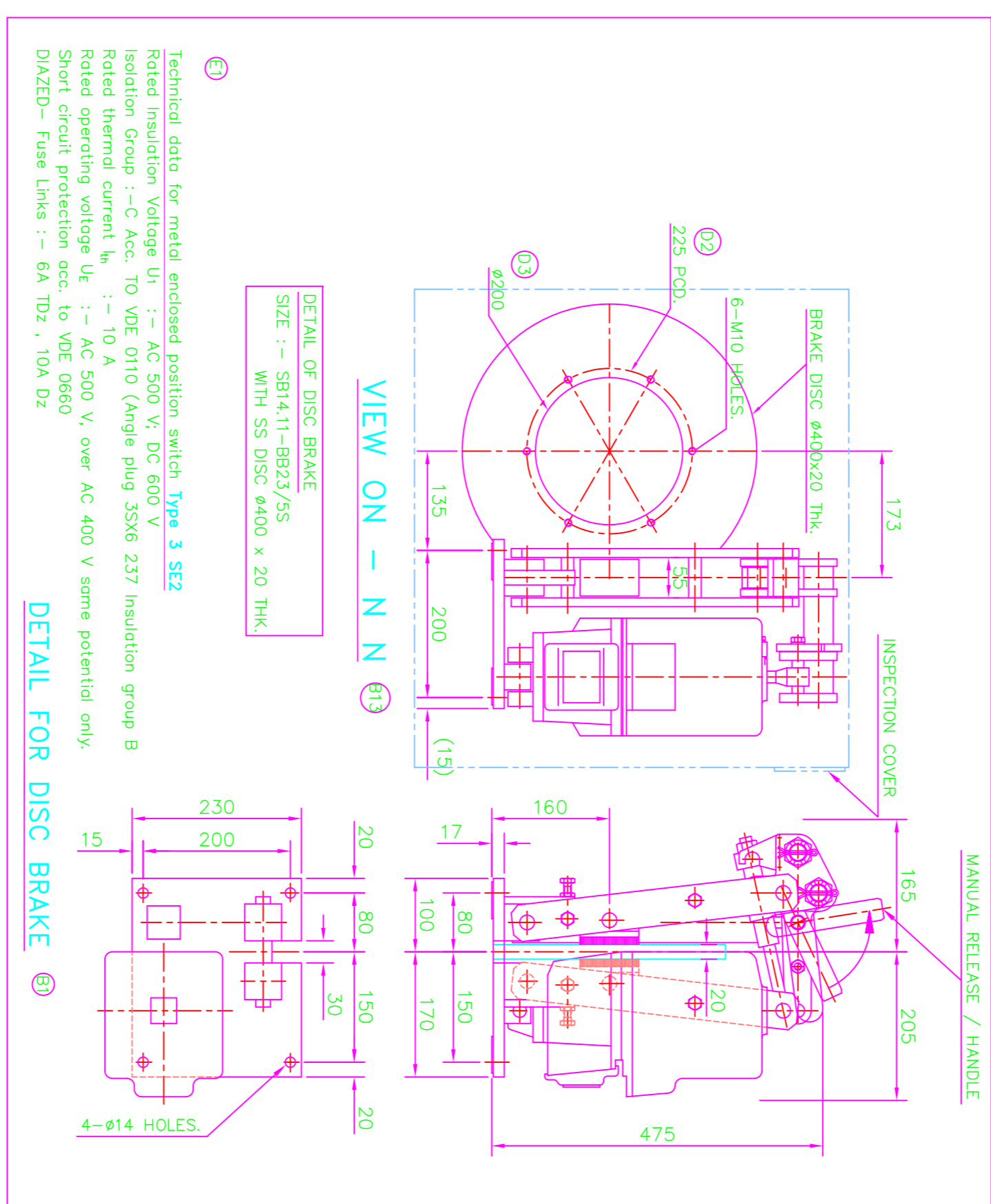
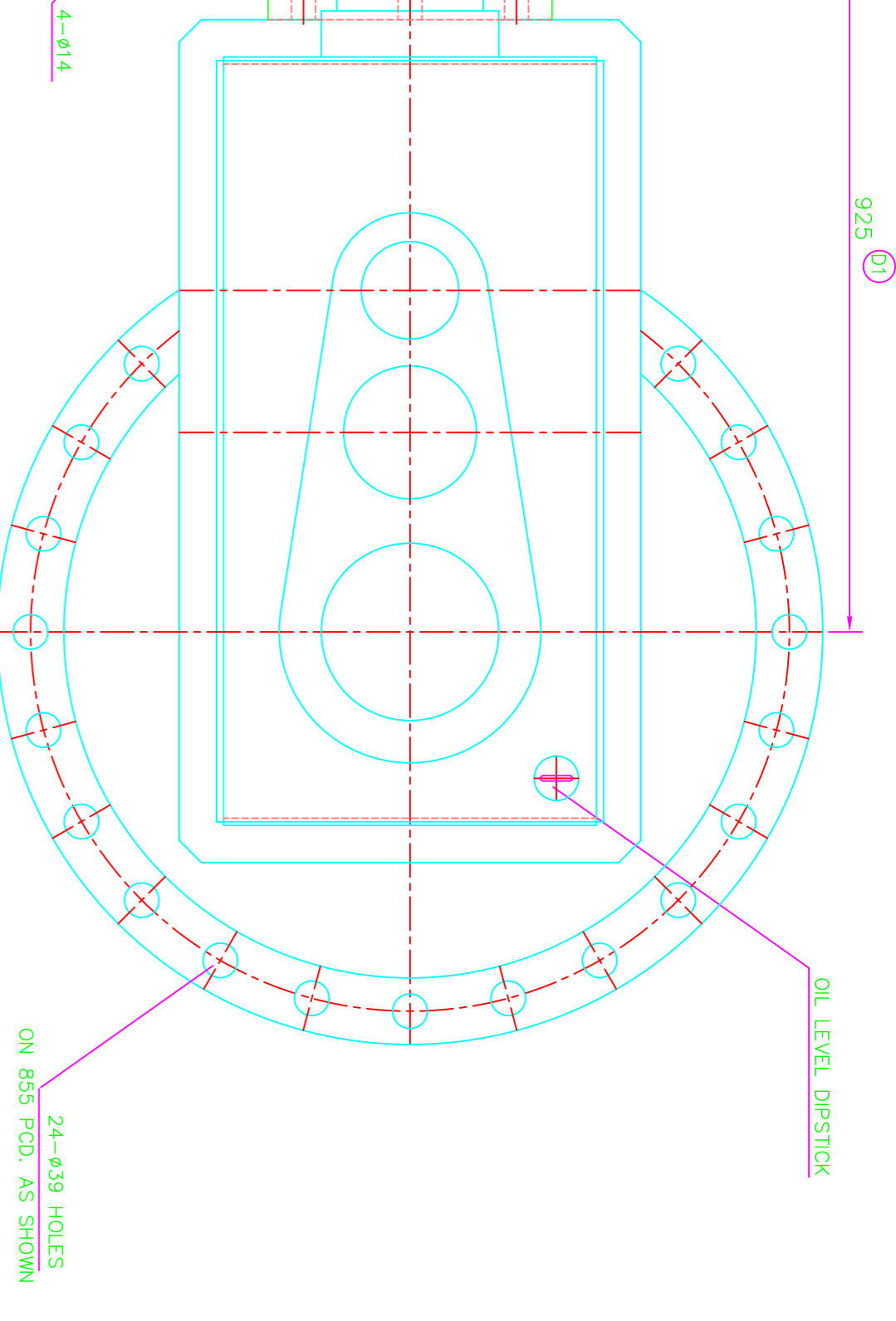
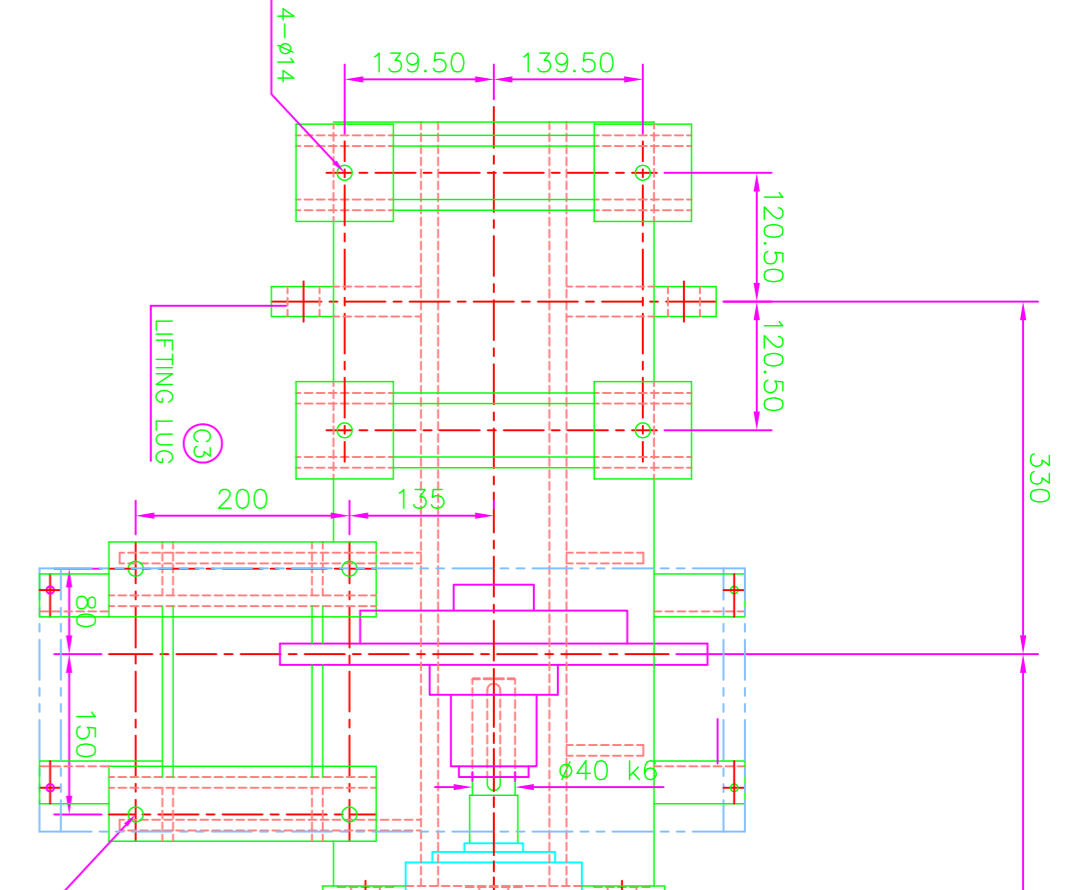
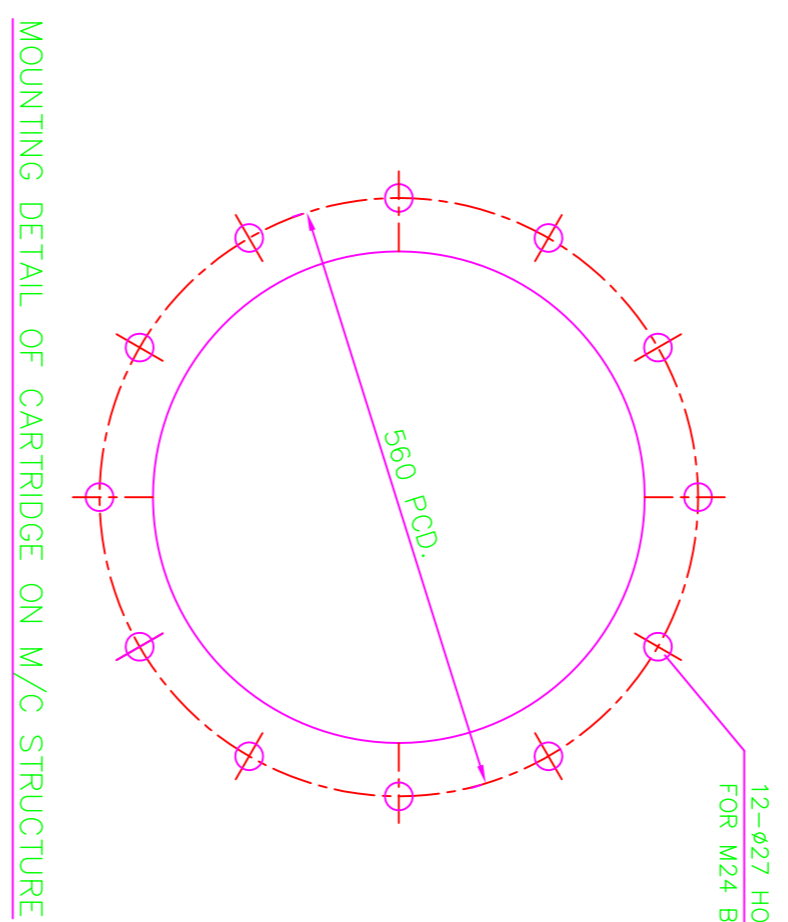

TECHNICAL DESCRIPTION OF SLEWING DRIVE

BEVEL & HELICAL / PLANETARY CARTRIDGE GEAR UNIT (REVERSIBLE TYPE)

QTY : 3 Nos./MACHINE

MOTOR POWER : 18.5 KW

MOTOR SPEED : 1480 RPM

OUTPUT SPEED : 1.6778 RPM

NOMINAL RATIO : 880 : 1

ACTUAL RATIO : 882.06 : 1

SPLASH LUBRICATION

OIL GRADE : ISO VG 220 (10C GRADE – SERVOMESH SP 220)

WEIGHT : 4500 KG. APPROX.(WITHOUT OIL)

GEAR CASE MATERIAL: Fe 410 WA I.S.: 2062

KEYS & KEYWAYS ARE AS PER DIN-6885 PART-1, SHAPE-A.

NO OF STAGE :- 5

Section

7

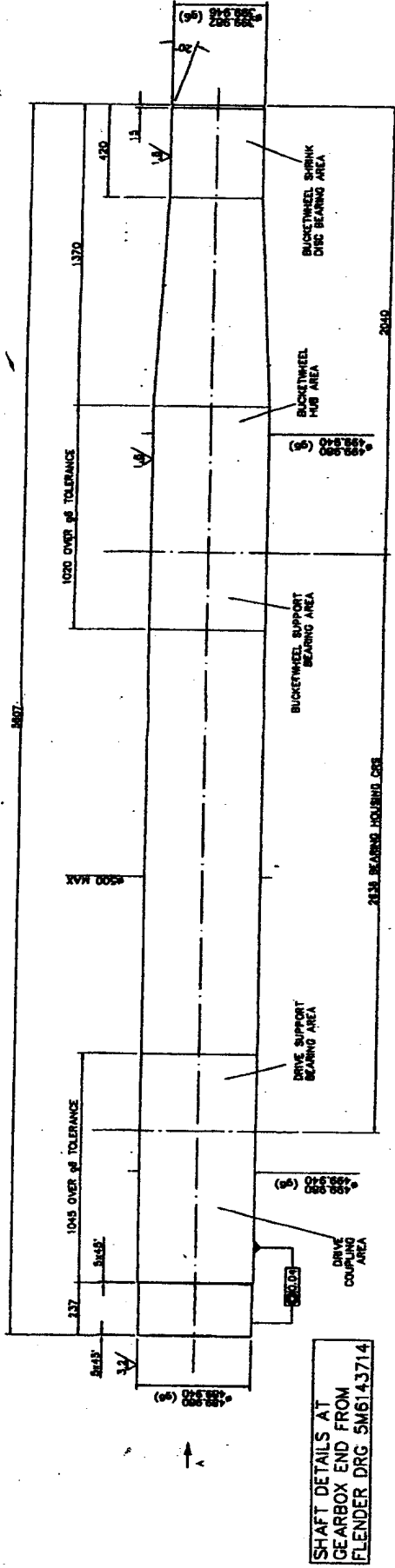

SHAFT DETAILS AT
GEARBOX END FROM
FLENDER DRG 5M6143714

AAS BUILT

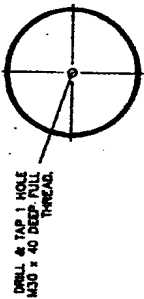

DRILL & TAP 1 HOLE
1430 ± 40 DEEP FULL
THREAD

VIEW ON ARROW A

NOTES:

1. ALL DIAMETER CHANGES TO BE BLENDED SMOOTH
2. MATERIAL: - CHEMICAL COMPOSITION TO BS970 PART 2, GRADE 826M40. MATERIAL TO BE VACUUM DEGASSED - MAX. HYDROGEN CONTENT 3 PARTS PER MILLION. HEAT TREATED TO GIVE THE FOLLOWING MECHANICAL PROPERTIES: - MINIMUM TENSILE STRENGTH 985N/mm² - CHARTY IMPACT VALUE 50 JOULES AT -10°C - GRAIN SIZE TO BE 6 OR FINER
3. SMOOTH ALL SHARP EDGES
4. AFTER MACHINING, PROTECT ALL DIAMETER SURFACES
5. NO HARDMARKING OF DRAWING NO. IS ALLOWED
6. MECHANICAL & CHEMICAL TEST CERTIFICATES REQUIRED SHAFT TO BE ULTRASONICALLY TESTED MANUFACTURE TO BE SUBJECT TO AN INSPECTION PLAN (BY OTHERS)

DRILL & TAP 3 HOLES
1424 ± 40 DEEP FULL
THREAD ON 200 PCD.

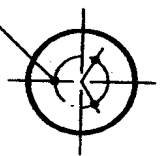

VIEW ON ARROW B

IES
OA
LOC
11/09/08

DO NOT SCALE IF IN DOUBT - ASK		SOUTH AFRICAN PORT OPERATIONS BOX ONE TENDER - SALDANHA STACKER RECLAIMER CONTRACT HOURS SANCTION NO. 3817/01	
metso minerals		METRO MINERALS (Pty) Ltd P.O. BOX 871 AUSTON VILLE RD WINTERBURY 2320 ENGLAND	
81.33kg		707320	
1:10		BUCKETWHEEL SHAFT	
FIRST ISSUE		11 A	

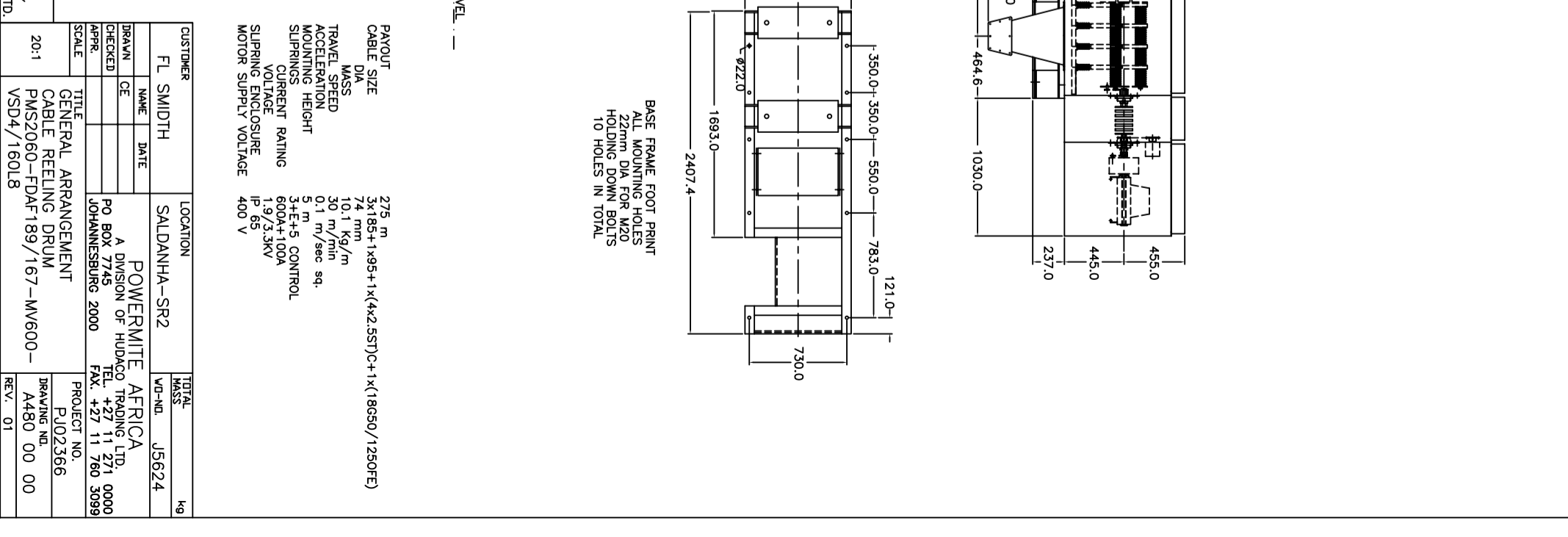
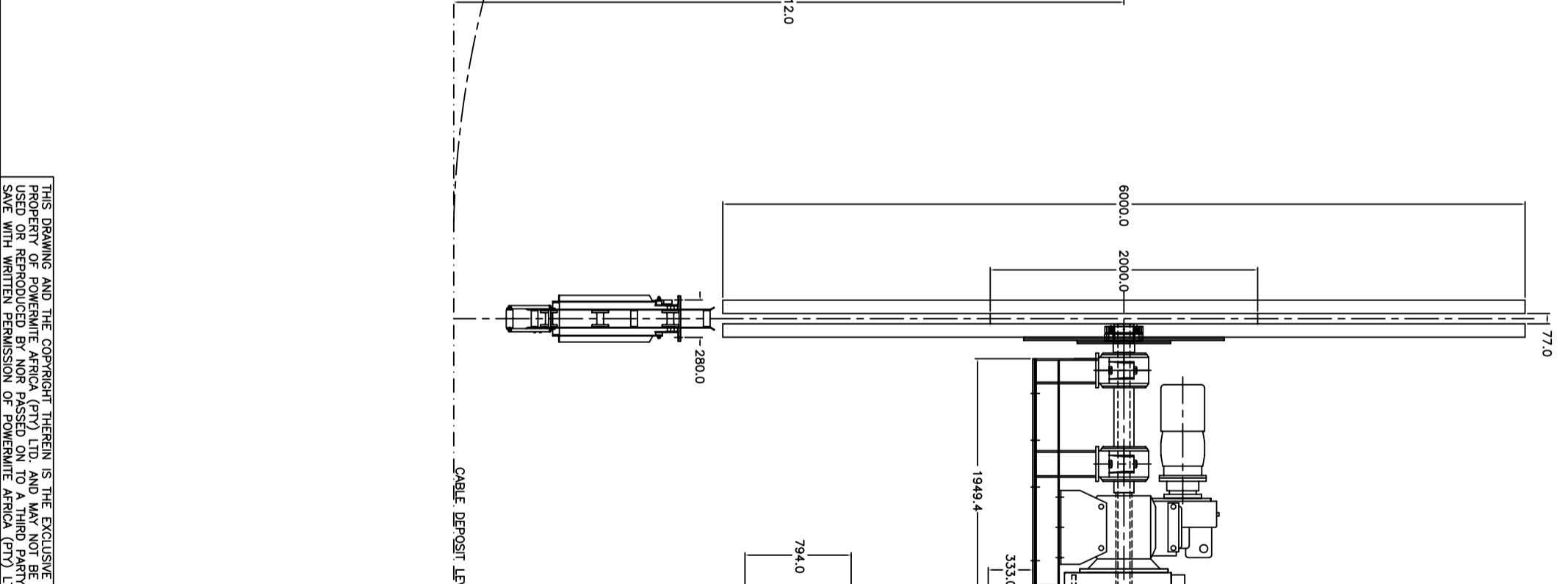
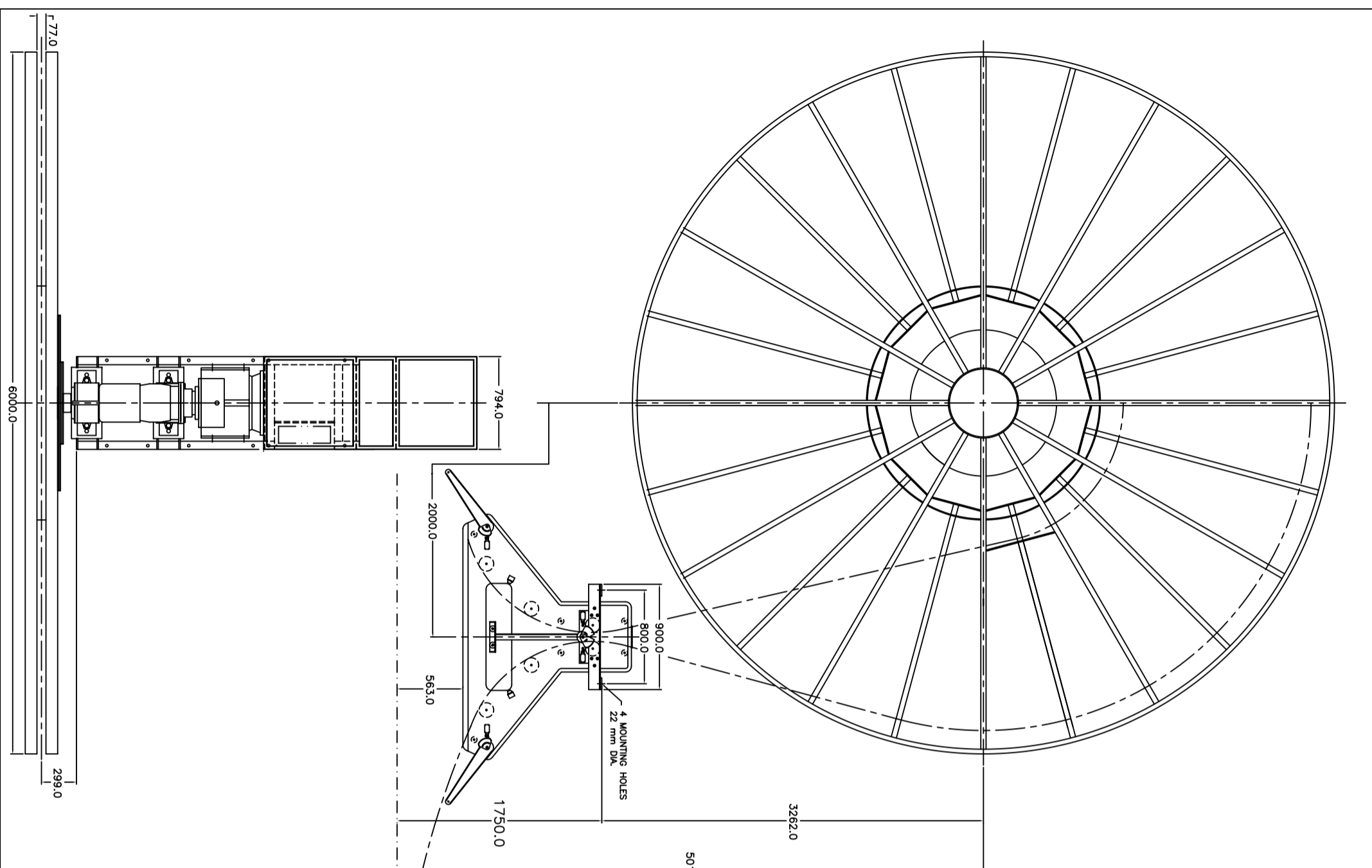

THIS DRAWING AND THE COPYRIGHT THEREIN IS THE EXCLUSIVE PROPERTY OF POWERMITE AFRICA (PTY) LTD. AND MAY NOT BE USED OR REPRODUCED BY NOR PASSED ON TO A THIRD PARTY SAVE WITH WRITTEN PERMISSION OF POWERMITE AFRICA (PTY) LTD.

CUSTOMER		LOCATION	TOTAL MASS
FL SMIDTH		SALDANHA-SR2	J5624
NAME	DATE	PROJECT NO.	
CE		P02366	
CHECKED		DRAWING NO.	
APPR		A480 00 00	
SCALE	TITLE	REV. 01	
20:1	GENERAL ARRANGEMENT		
	CABLE REELING DRUM		
	PMS2060-FDAF189/167-MV600-VSD4/160LB		

PAYOUT
 CABLE SIZE 275 m
 DIA 3x185+1x95+1x(4x2.5ST)C+1x(18G50/1250FE)
 MASS 74 mm
 TRAVEL SPEED 10.1 Kg/m
 ACCELERATION 30 m/min
 MOUNTING HEIGHT 0.1 m/sec sq.
 SLIPRINGS 5 m
 CURRENT RATING 3+E+5 CONTROL
 VOLTAGE 600A+100A
 SLIPRING ENCLOSURE 1.9/3.3kV
 MOTOR SUPPLY VOLTAGE IP 65
 400 V

BASE FRAME FOOT PRINT
 ALL MOUNTING HOLES
 22mm DIA FOR M20
 HOLDING DOWN BOLTS
 10 HOLES IN TOTAL



Note: If hardcopy, check electronic system for latest revision

**Transnet Capital Projects Document Management
Contractor Documentation Submittal Requirements**

DOC-STD-0001

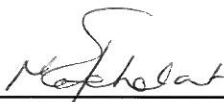
Prepared by:  21/09/2009
R. Herholdt Date

Reviewed by:  6/09/2009
N Uys, Q Keen, G Whyte Date

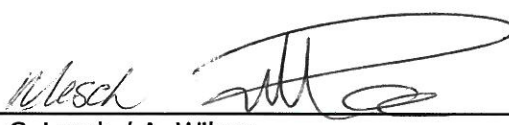
Approved by:  13/10/09
C. Lesch / A. Wilson Date

03	25/08/2009	NEC Requirements checked
02	18/05/2009	CORRECTIONS
01	23/01/2009	CORRECTIONS
0	15/12/2008	ISSUE FOR REVIEW
Rev No.	Date	Revision Details



Note: If hardcopy, check electronic system for latest revision

Table of Contents

1. Purpose	1
2. Scope	1
3. References	1
4. Definitions / Abbreviations.....	2
4.1 Definitions	2
4.2 Abbreviations	3
5. Responsibilities	4
5.1 <i>Contractor</i>	4
5.2 <i>Sub-Contractors</i>	4
6. Procedure	4
6.1 Documentation to be Submitted	4
6.1.1 Contractor Documentation Schedule (CDS) (DOC-FAT-0001)	4
6.2 Contractor Documentation Register (CDR) (Annexure B)	5
6.3 Format in which Documentation is to be submitted	5
6.4 Documentation Preparation Requirements	6
6.4.1 Quality	6
6.4.2 Standards and Codes.....	6
6.4.3 Language	6
6.4.4 Units and Dimensions	6
6.4.5 Sizes of Documentation	6
6.4.6 Documentation with Multiple Sheets.....	7
6.4.7 Details Required on Documentation.....	7
6.5 Electronic Documentation Requirements	8
6.5.1 Table 1: Acceptable File Formats.....	8
6.5.2 Security.....	11
6.5.3 Scanning Requirements	11
6.6 Documentation Numbering	12
7. Revising Documentation.....	12
7.1 Revision Notes	12
7.2 Indicating Revisions	13
7.3 As-Built / Final Revisions.....	13
8. Documentation Submission	13
8.1 Documentation Submission Format	13
8.2 Electronic Transmission	13
8.3 Hard Copy Transmission	14
8.4 Transmittal Notes (Annexure A)	14
8.5 Formats and Quantities of Documentation	14
8.6 Address for Submission	14
9. Review and Acceptance of <i>Contractor</i> Documentation.....	14
9.1 Contractor Review Label (CRL).....	15
9.1.1 First Submission of Documentation.....	15



Note: If hardcopy, check electronic system for latest revision

9.1.2	Review of Documentation	15
9.1.3	Review Period	16
9.1.4	Revised Documentation	16
10.	As-Built / Final Documentation	17
10.1	Definition of Final and As-Built Status of Documentation.....	17
10.1.1	"Final" Documentation	17
10.1.2	"As-Built" Documentation	17
10.2	Preparation of As-Built Documents	17
10.2.1	Transnet Capital Projects Documents	17
10.2.2	Design, Supply and Install Contractor Documents	18
11.	Installation, Maintenance and Operating Manuals and Data Books.....	18
12.	Cancelling and Superseding Documentation	19
12.1	Superseding.....	19
12.2	Cancelling.....	19
13.	Records	19



Note: If hardcopy, check electronic system for latest revision

1. Purpose

This standard outlines the documentation requirements that are to be implemented by the *Contractor* for the preparation, submission, receipt, review, and collection of Technical and (or) Deliverable Documentation, as detailed in the Contractor Documentation Schedule (CDS).

Contractor documentation is of the utmost importance for the in-house Engineering activities as the information contained in the *Contractor's* documentation interfaces with several other disciplines for the Engineering, e.g., Mechanical, Structural, Piping, Control and Instrumentation, Electrical, etc.

The supply of high quality documentation within the time required as defined in the '*Works Information*', Contractor Documentation Schedule (CDS), and *Contract* must be considered as one of the main objectives by the *Contractor*.

2. Scope

This scope defines the *Contractor's* responsibilities in terms of the preparation of all the *Contractor* Deliverables required for each *Contract*.

3. References

- ISO 9001:2000 - Quality Management Systems Requirements
- SANS 10111 - Code of Practice for Engineering Drawings
- SANS 10143 - Building Drawing Practice
- DOC-FAT-0001 - Contractor Documentation Schedule (CDS)
- DOC-FAT-0002 - Contractor Documentation Register (CDR)
- DOC-FAT-0003 - Contractor Review Label (CRL)
- DOC-FAT-0004 - Contractor Review Label (CRL) for drawings



Note: If hardcopy, check electronic system for latest revision

4. Definitions / Abbreviations

4.1 Definitions

'As-Built' Document	Is a final record of what was actually installed / constructed according to the Fabrication / Construction <i>Contractor</i> , and includes all deviations or changes from the approved AFC document(s). As-Built document(s) are required to reflect the same degree of detail as the original document(s). As-Built document(s) shall be done by all <i>Contractors</i> .
<i>Contract</i>	Formal document evidencing agreement between <i>Employer</i> and <i>Contractor</i> for supply of on site or off site services (generic term used for Purchase Orders, Contracts and Service Orders in this Procedure).
<i>Contractor</i>	The party to a contract that provides services to the <i>Employer</i> (generic term used for Vendors, Suppliers, Contractors, Consultants, etc.).
Controlled Document	Any document where its revision and distribution are recorded to ensure that Project Team Members holding a copy of the document have the current revision, and will receive future revisions, subject to a formal review and approval process.
Documentation	Collective term used to describe drawings and documents, e.g., letters, faxes, drawings, specifications, reports, manuals, standards, publications, software, etc.
Document Control	The function that ensures systematic registration, distribution, retrieval, status reporting, and storage of revision controlled documentation, typically Technical and (or) Deliverable documentation.
Document Management	Is the over-arching term used to describe the management of documentation on a Project.
<i>Employer</i>	The party to a Contract or Purchase Order to whom the goods are supplied or for whom the work or services are performed. For this project Transnet Capital Projects is the <i>Employer</i> .
<i>Employer's</i> Documentation	Shall mean all documentation issued to <i>Contractors</i> by the Project.
Engineering Deliverables	Technical documentation generated by Engineering, i.e. drawings, drawing registers, Engineering Document Registers, calculations, requisitions, equipment lists, design specifications, etc.



Note: If hardcopy, check electronic system for latest revision

'For Record' Document	A set of record drawings / documents conforming to the marked up prints, drawings and other data, handed over to the <i>Employer</i> as part of the Project Handover Procedure.
Master Document	The original wet signed (signature) document which is held by Project Office Document Control.
Native/Source Document	Original electronic file format of documentation.
Project Deliverables	Is any document, drawing, report, register, task, etc.
<i>Project Manager</i>	The Project Manager is appointed by the <i>Employer</i> , and his role is to manage the Contract for the <i>Employer</i> .
Squad Checking	The review of technical documentation by multiple Engineering disciplines in order to ensure co-ordination, communication and interface between the various disciplines; done in an area specifically allocated for the review of documentation; the process / activity is controlled by Document Control but the work is executed by the Engineering Team.
Tender Document	The formal document that expresses the terms, both Commercial and Technical, against which a Tenderer submits its Tender for Contracts.
Transmittal	Is documented evidence of the formal distribution of documentation to recipients which display Transmittal No., Title, Date, Issue Reason, Revision No. etc. It is evidence of distribution and receipt of documentation.
Uncontrolled Document	Any copy of a document where distribution is not required to be recorded, and that does not require revision control or formal review.
Working Document	The main working copy of an original document where proposed changes are recorded for incorporating into subsequent revisions.
'Works Information'	Shall refer to the <i>Works Information</i> as defined in the Contract

4.2 Abbreviations

AB	As-Built / Recorded Documentation
----	-----------------------------------



Note: If hardcopy, check electronic system for latest revision

AFC	Approved For Construction
CDR	Contractor Documentation Register
CDS	Contractor Documentation Schedule
CRL	Contractor Review Label
DC	Document Control
DCIS	Document Control Instruction Sheet
EDMS	Electronic Document Management System
FN	Final
RE	Responsible Engineer

5. Responsibilities

5.1 *Contractor*

The *Contractor* is responsible for submitting all documentation, required by the Contract, via Document Control to the relevant *Project Manager*, to comply with the requirements of this standard.

The *Contractor* is responsible for setting up and maintaining his own internal Document Control Process to ensure traceability and accountability for all information submitted to the *Project Manager*, and all information issued to Sub-Contractors.

5.2 *Sub-Contractors*

The *Contractor* is responsible for providing the *Sub-Contractors* with all the relevant information, and for ensuring that the *Sub-Contractors* applies the Standard, and submit their data via the *Contractor* for formal submission to the *Project Manager*. (If the *Contractor* sub-contracts work, he is responsible for providing the Works as if he had not sub-contracted.)

6. Procedure

6.1 Documentation to be Submitted

6.1.1 Contractor Documentation Schedule (CDS) (DOC-FAT-0001)

The CDS states the Employer's requirements for:



Note: If hardcopy, check electronic system for latest revision

- The document types to be submitted by the *Contractor* at various stages of the Contract
- The timing for documentation to be submitted by the Contractor
- The *Project Manager* completes the Contractor Documentation Schedule (CDS) and includes it with the Enquiry and Contract as an attachment / annexure to the 'Works Information' document. The *Contractor* submits documentation as required by the Contractor Documentation Schedule (CDS), within the time specified in the Contract All documentation shall be submitted according to the dates specified in the Contractor Documentation Schedule (CDS).

6.2 Contractor Documentation Register (CDR) (Annexure B)

The Contractor Documentation Register (CDR) is a list of documentation that the *Contractor* is to submit in accordance with the *Contract*. The *Contractor* is to use the Contractor Documentation Schedule (CDS) as the basis for developing the Contractor Documentation Register (CDR). The CDS is the minimum requirement, and the *Contractor* is still responsible to include all documentation on the CDR required for the successful completion of the contract even if no CDS has been included in the *Contract*.

The title of the documentation shall adequately define and describe the facility and equipment where applicable. The Contractor Documentation Register (CDR) must be submitted within 2 weeks of the *Contract* award date, unless otherwise indicated on the Contractor Documentation Schedule (CDS) or in the Contract. Once the Contractor Documentation Register (CDR) is submitted, the *Project Manager* in conjunction with Document Control assigns document numbers to each document. The Contractor Documentation Register (CDR) is reviewed and returned to the *Contractor* as defined elsewhere in this Standard. The *Contractor* is to use the exact document numbers and titles as provided and listed by the *Project Manager* on the Contractor Documentation Register (CDR), on each of the documents.

The Contractor Documentation Register (CDR) is a 'live' document that shall be updated and re-submitted by the *Contractor* on a regular basis to reflect any changes made, e.g., updated planned / actual submission dates or addition of new documents requiring new numbers. Changes to a row(s) of the register shall be highlighted in colour across the entire row(s).

The Contractor Documentation Register (CDR) shall be submitted in Excel (electronic format) as well as PDF format upon each submission to the Project, and shall also be submitted with the final documentation, unless otherwise agreed as per par 6.3.

The forecast and actual submission dates shall reflect the dates of the next issue of the documentation, and once this submission reaches conclusion the dates are to be updated to reflect the next issue, i.e., the as-built documentation submission dates.

6.3 Format in which Documentation is to be submitted

Although the aim of this Standard is to encourage all documentation to be managed and submitted electronically the *Contractor* can apply to the *Project Manager* to have these requirements changed to accept only paper copies of all documentation

Note: If hardcopy, check electronic system for latest revision

6.4 Documentation Preparation Requirements

6.4.1 Quality

Documentation shall be of the highest quality to allow immediate and accurate use by the Project Manager, i.e., without any need for interpretation due to possible illegibility, or prints / copies of poor quality.

Any illegible or indecipherable drawings will be systematically rejected and returned to the *Contractor*, who shall in no case allege documentation being rejected and returned as a reason for any delay affecting delivery.

All documentation shall have sufficient borders for punching as required for filing purposes.

6.4.2 Standards and Codes

All documentation shall conform to the latest revisions of the following, i.e.,:-

- SANS 10111 - Code of Practice for Engineering Drawings, or
- SANS 10143 - Building Drawing Practice, or
- ISO 9001:2000 - Quality Management Systems Requirements

6.4.3 Language

All drawings and documents shall be in English.

6.4.4 Units and Dimensions

All units and dimensions on the *Contractor's* documentation shall be in SI units, unless otherwise specified.

6.4.5 Sizes of Documentation

6.4.5.1 Drawings

The following standard drawing sizes shall be used:

- A3 - 277 x 420mm
- A2 - 420 x 594mm
- A1 - 594 x 841mm
- A0 - 841 x 1189mm

Note:

- Drawings wider than A0 are not acceptable to the *Project Manager*
- Hard copy drawings shall be printed out at actual size, e.g., shall not print A1 size when drawing size is A0
- A4 drawings are prohibited unless issued as part of a document.



Note: If hardcopy, check electronic system for latest revision

6.4.5.2 Other Documents

All the *Contractor's* documentation other than drawings shall be prepared on standard A3 or A4 size sheets suitable for insertion into an A4 (W71) hard-core binder (file).

All documentation shall have sufficient borders to allow for punching.

6.4.6 Documentation with Multiple Sheets

6.4.6.1 Drawings

If a series of drawings of a particular area is produced by the *Contractor* (e.g., loop diagrams which may have fifty (50) or more sheets) one sequential drawing number shall be used with a series of sheet numbers.

Where more than one sheet is used, the first sheet (numbered 01) shall incorporate an index for all the other sheets in the series, including their current revision status and date.

6.4.6.2 Documents

The *Contractor's* documents with several sheets (e.g., data sheets, reports, etc.) shall be compiled as sets, i.e., a multi sheet document identified as a single document with a single document number. Thus, each sheet is identified individually, e.g., "sheet 10 of 15" and all documents shall be numbered from page 2 onwards.

Each set shall include a Table of Contents and the identification data shall as a minimum contain the following, i.e., the document number, revision number, page number and continuation information shall appear on every page of the multiple page documents. The front sheet of each document shall be page 1; however the number or wording "page 1" is not shown on the first page.

6.4.7 Details Required on Documentation

Each drawing and document shall be identified with the following information, i.e.,:-

- Project Name and Number
- Contract Number or Purchase Order Number
- Equipment Tag Number(s) (if applicable)
- Manufacturer's model / type (if applicable)
- Official Name of *Contractor's* Company
- *Contractor's* Reference Number
- Project Document or Drawing Number
- Electronic File Name (identical to the *Employer's* Document or Drawing Number and not the *Contractor's* Document or Drawing Number)
- Identification and signature of Originator, Checker, Approver, PR Eng, etc.
- Complete Descriptive Title
- Revision



Note: If hardcopy, check electronic system for latest revision

- Date

6.5 Electronic Documentation Requirements

No "Protection" or "password" will be placed on electronic files.

Electronic submissions shall conform to the minimum quality standard as listed below, i.e.,:-

- File Formats to be submitted
- All deliverables submitted by the *Contractor* must be supplied in the formats listed below, and be editable using the software listed in Table 1. Only exceptions that have prior approval from the *Project Manager* will be accepted. Software used shall be the latest generation, and where appropriate, shall be regularly upgraded.

Note:

All electronic documents shall be submitted in Adobe Acrobat (PDF) format and the 'Native' file shall be included at the final submission.

6.5.1 Table 1: Acceptable File Formats

Document Type	Description
Drawings	Native: Micro Station 2003 or later
	Published In: Adobe Acrobat (PDF) version 7 or later
Data Sheets (other than instrumentation)	Native: MS Excel 2003 or later
	Published In: Adobe Acrobat (PDF) version 7 or later
Data Sheets (Instrumentation)	Native: As per software used or as otherwise specified in Contract
	Published In: Adobe Acrobat (PDF) version 7 or later
Engineering Data Lists	Native: MS Excel 2003 or later
	Published In: Adobe Acrobat (PDF) version 7 or later
Calculation Outputs / Results	Native: As per software used or as otherwise specified in Contract
	Published In: Adobe Acrobat (PDF) version 7 or later
Document Viewers – Redlining	Adobe Acrobat v7 minimum with "Comments" enabled
All Reports	Native: MS Word 2003 or later
	Published In: Adobe Acrobat (PDF) version 7 or later
Report supporting Data including: Calculations, Charts,	Native: As per software used or as otherwise specified in Contract



Note: If hardcopy, check electronic system for latest revision

Graphs, Indexes, etc.	Published In: Adobe Acrobat (PDF) version 7 or later
Manuals	Native: MS Word 2003 or later
	Published In: Adobe Acrobat (PDF) version 7 or later
General Documents	Native: MS Word 2003 or later
	Published In: Adobe Acrobat (PDF) version 7 or later
Presentations	Native: MS PowerPoint 2003 or later
	Published In: Adobe Acrobat (PDF) version 7 or later
Colour Photographs / Scanned Images	Native File format: JPG Compression level 1%
Graphic Imagery	Published images in: TIF uncompressed or WMF
	Native image format: Corel Draw 7 CDR file
	Adobe Photoshop 7.0 PSD
	PowerPoint 2000 PPT file
Project Schedules	Native: Primavera P6 (preferred)
	Native: MS Project
	Published In: Adobe Acrobat (PDF) version 7 or later
Databases (preferred)	MS SQL Server 2000
Databases (non-preferred)	ODBC compliant
	Microsoft Access 2003
Data Compression	Software: WinZip 8.0
Other General Project Data	Native: Microsoft Office 2003 application or later
	Published In: Adobe Acrobat (PDF) version 7 or later

6.5.1.1 Native File

Native files shall be clean of all extraneous fonts, formats and styles to ensure inadvertent reformatting and format adjustments or difficulties that do not eventuate in downstream handling of documents.

6.5.1.2 Adobe Acrobat (.PDF) Files

PDF files shall be of a high quality and without dark background shading as definition may otherwise become lost.

The quality of Adobe Acrobat (.PDF) files shall be such that a hardcopy of a laser printed A1 Adobe Acrobat (.PDF) drawing can clearly be read in A3 size. Similarly A3 and A4



Note: If hardcopy, check electronic system for latest revision

Adobe Acrobat (.PDF) file quality shall be such that hardcopy of a laser printed A3 or A4 Adobe Acrobat (.PDF) document can clearly be read in A4 size.

The Contractor shall physically test and confirm this prior to transmitting Adobe files.

PDF files shall be saved as "Reader Extent" to make provision for the use of electronic signatures.

PDF files shall be "Optimized" to improve Quality and then "Reduce File Size" through Adobe.

6.5.1.3 Databases

Databases shall be presented in compatible format on CD Rom as specified in Table 1. Multi format documents (created from several files) shall be combined and submitted as a single Adobe Acrobat (.PDF) file.

6.5.1.4 Drawing Files

These shall be submitted in Adobe Acrobat (.PDF) and the 'Native' file format shall be submitted on the final submission unless otherwise specified. 'Native' files shall include reference / border files, etc.

A single file shall be submitted per document, i.e., under no circumstances shall different drawings with different numbers appear on one sheet under one file name, nor shall a drawing with multiple sheets be saved into one electronic file.

All CAD drawings shall be contained in one single merge file, any form of ex Ref or Reference File will not be accepted.

6.5.1.5 Sketches

These shall be A3 or A4 size scanned as Adobe Acrobat (.PDF) file.

6.5.1.6 Text Documents

Each page of a single document shall be collated into one file. (The "wet" signature Contractor Review Label (CRL) coversheet, where required, is inserted at the beginning of the document prior to review).

6.5.1.7 Tables / Diagrams

These shall be A4 and A3 size only.

6.5.1.8 Reports

Reports containing Word, Excel, DGN, DWG, brochures, etc., shall be compiled as one Adobe Acrobat (.PDF) file.

Note:



Note: If hardcopy, check electronic system for latest revision

Original colour hardcopies shall be scanned in colour to ensure all details of paper documents.

6.5.1.9 Photo's / Video's

Prints should be submitted of conventional photographs or prints and digital files of electronic images, or as specified by the Project Manager.

6.5.2 Security

Files shall be clear of known viruses and extraneous (irrelevant) macro's. The *Contractor* shall at all times have the latest generation of virus protection software. The *Contractor* shall ensure appropriate security systems are in place to prevent unauthorized electronic distributions and (or) unauthorized editing or manipulation of electronic files.

6.5.3 Scanning Requirements

Where possible 'native' files shall be converted to PDF rather than scanned from hardcopy.

Where this cannot be done all drawings and documents shall be manually scanned black and white except where colour image and fonts are required or necessary.

The settings below should be adhered to where possible and may vary depending on scanning software used. Where images rendered with these settings are unreadable, operators shall use their discretion, and adjust colour depth and resolution accordingly.

6.5.3.1 Scan Settings

- Resolution:-

Black and White - 200 dpi

Colour - 100 dpi

Fine Line Drawings - 300 dpi

- Image Type:-

Black and White - 1 Bit

Colour Line Drawings - 8 Bit (256 colours) minimum

Colour photos and rendered images - 24 Bit

Use automatic threshold to determine the white and black points

- Other Criteria to Adhere to:-

Rotate to correct reading (i.e., viewable at correct orientation)

De-skew (i.e., straighten if on a slant)



Note: If hardcopy, check electronic system for latest revision

De-speckle (i.e., remove background dirt)

Optimized (i.e., reduce file size)

Note:

When a scanned drawing is printed to be re-scanned, subsequent to, e.g., mark-ups or signatures, then it shall be scanned at a setting of 400 dpi.

6.6 Documentation Numbering

Once the Contractor Documentation Register (CDR) has been submitted by the *Contractor*, Document Control will allocate the *Employer's* documentation numbers on the Contractor Documentation Register (CDR) and return it to the *Contractor*.

A unique sequence number is allocated to each document and remains the same for each submittal of that specific document.

The *Contractor* shall use the *Employer's* document numbers and titles exactly as per the Contractor Documentation Register (CDR) on all documentation submitted.

Electronic file names for all documentation shall be exactly as per the *Employer's* documentation numbers, including the revision number.

7. Revising Documentation

All documentation carries a revision block, which must be completed in full before submitting to the *Project Manager*, and typically denotes the following:-

- NO. - Revision Number, e.g., 00, 01, etc.
- DESCRIPTION - Describes the status, e.g., Issued for Tender and a brief description of the changes made.
- BY - Person responsible for revising the document
- CHK'D - Person responsible for checking the revised document
- APP'D - Person responsible for approving the revised document
- DATE - Date of the revised document

7.1 Revision Notes

The revision block should record each change in revision with a brief but specific description of the changes made.

Terms such as "Minor Revision" or "General Revisions" shall be avoided in favour of a more specific notation.

More than one line may be used but only the revision number and date together with the relevant initials shall appear in the top line.



Note: If hardcopy, check electronic system for latest revision

7.2 Indicating Revisions

Revisions shall be clearly identified by placing a revision triangle with the correct revision number in the right hand column in the case of documents, and is adjacent to the area on the document that has been changed.

All revisions made on drawings shall be enclosed by a cloud except in cases where to add a cloud detracts from the readability of the drawing. At subsequent revisions all clouds and revision triangles from the previous formal revision shall be removed from the drawing.

7.3 As-Built / Final Revisions

Should documentation require changes upon completion of Construction, it shall be revised to an "As-Built" status, as well as bear the wording "Certified As-Built", which is indicated in the revision block of the documentation.

Should documentation not require any changes upon completion of Construction, it shall be revised to a "Final" status, as well as bear the wording "Certified Final", which is indicated in the revision block of the documentation.

8. Documentation Submission

8.1 Documentation Submission Format

All documentation shall be submitted under cover of a *Contractor's* Transmittal Note.

8.2 Electronic Transmission

The Contractor Documentation Schedule (CDS) defines which documentation shall be transmitted electronically. All electronic documentation shall be transmitted on CD ROM unless otherwise agreed as per Par 6.3.

Documentation submitted on CD ROM shall be contained in a zip file with the Transmittal Note enclosed.

Note:

In the event of documentation required urgently and the *Contractor* is not able to submit a CD ROM and (or) hard copy format timeously, then e-mail transmission may take place (but in extreme cases only)

Per e-mail - the file size may not exceed 5 MB and the Transmittal Note shall be attached.

The *Contractor* is still required to submit the relevant CD ROM to Document Control without delay.

When sending an e-mail the *Contractor* shall ensure that the subject field of the e-mail is completed as follows, i.e.,:



Note: If hardcopy, check electronic system for latest revision

- Contract Number – *Contractor's* Transmittal Number and Description of documentation transmitted.

8.3 Hard Copy Transmission

Documentation shall be submitted in printed hard copy format unless otherwise stated on the Contractor Documentation Schedule (CDS).

8.4 Transmittal Notes (Annexure A)

All documentation shall be submitted under cover of the *Contractor's* Transmittal Note indicating all *Contract* references (i.e., Project No, *Contract* No, etc.), Project Documentation Number(s), Revision Number, Title and Chronological listing of transmitted documentation.

The *Contractor's* Transmittal Note shall state the purpose / issue reason of the documentation submission.

Documentation for different purposes must be sent on separate *Contractor* Transmittal Notes. The *Contractor* shall note that documentation will be rejected if this requirement is not met.

The *Contractor* Transmittal shall be signed, date stamped and returned to the *Contractor* by Document Control.

8.5 Formats and Quantities of Documentation

The required number of copies and formats of documents / drawings shall be specified in the Contractor Documentation Schedule (CDS).

A typical example of quantities and formats would be as follows:-

- Pre-Construction – Hard copy and PDF (to be specified in 'CDS')
- Construction – Hard copy and PDF (to be specified in 'CDS')
- As-Built – Red Lined – Hard copies (Normally 3 off) (to be specified in CDS')
- Certified As-Built / Final – Hard copies (full size) and CD ROMs containing PDF and 'Native' file formats (to be specified in 'CDS')

8.6 Address for Submission

The address of submission will be as specified in the *Contract* and all submissions will be identified with the Contract Number, and the responsible *Project Manager*. All deliveries will be made to Document Control who will distribute the documentation to the relevant *Project Manager*.

9. Review and Acceptance of *Contractor* Documentation

The *Contractor* submits documentation as the *Contract* requires to the *Project Manager* via Document Control for review and acceptance.



Note: If hardcopy, check electronic system for latest revision

9.1 Contractor Review Label (CRL)

The purpose of the Contractor Review Label (CRL) is for the *Project Manager* to assign a review code to the reviewed documentation denoting the status of the documentation after consolidation of comments. The Contractor Review Label (CRL) is to be inserted by the *Contractor* as follows:-

9.1.1 First Submission of Documentation

The first revision is revision '0', with subsequent revisions '1', '2', '3', etc.

9.1.2 Review of Documentation

Acceptance of documentation by the Project will in no way relieve the *Contractor* of their responsibility for the correctness of information, or conformance with the requirements. This responsibility rests solely with the *Contractor*.

Once documentation has been reviewed by the Project, all comments are consolidated and a review code is assigned on the Contractor Review Label (CRL) to the original reviewed / marked-up drawing / document by the *Project Manager*.

9.1.2.1 Review Codes for Contractor Documentation

The Review Code resulting from the review is as follows, i.e.,:-

- Code C1 – Accepted

The *Contractor's* design / submission of documentation is accepted and the *Contractor* only needs re-submit documentation only if major changes have been made. The next submission will be the for Approval of "Redline" and / or "Final " documentation.

- Code C2 – Accepted with Comments. Revise and Resubmit

In the event that the Project returns documentation with comments noted, the *Contractor* shall, within the '*period of reply*' as defined in the *Contract Data*, make the required changes and submit the revised documentation for further review on the next revision.

- Code C3 – Not Accepted. Revise and Resubmit for Review

In the event that the Project returns documentation with "Not Accepted, Revise and Re-submit" the *Contractor*, within the '*period of reply*'; make the required changes and re-submit the revised documentation on a new revision for further review. Should these revisions necessitate changes in other related documentation, the *Contractor* shall make the appropriate changes and re-submit all the revised related documentation for further review. The *Contractor* shall not proceed with any activities controlled by the *Contractor's* documentation until it has been re-submitted and acceptance indicated.

The *Contractor* revises and re-submits documentation but on the next revision until a review code 'C1' is achieved. This review process shall not entitle the *Contractor* to submit any claims due to time loss.



Note: If hardcopy, check electronic system for latest revision

- Code C4 – Review Not Required

Documentation signed at "Code C4" level is considered to be for information only and does not require further submission, and shall not be returned to the *Contractor*. However, Document Control shall issue a Transmittal only to the *Contractor* in this regard as notification.

9.1.2.2 Return of Reviewed Documentation

The original reviewed / marked-up drawing / document is scanned to PDF format and a copy is returned to the *Contractor* indicating the *Project Manager's* further instructions.

Return of the reviewed documentation is either in hard copy format, in which case the original reviewed / marked-up drawing / document is returned, or on CD.

Contractors will be advised by e-mail or fax (accompanied by a copy of the Project's Transmittal Note) that documentation is available for their collection.

9.1.3 Review Period

The *Contractor* shall allow the *Project Manager* the '*period of reply*' to review and respond to the *Contractor's* submission of documentation, i.e., from time of receipt by the *Project Manager* to the time of dispatch by the *Project Manager*. However, work shall proceed without delay in the event of late return of the documentation by the *Project Manager* with prior notification in writing by the *Contractor*.

9.1.4 Revised Documentation

On receipt of the reviewed documentation the *Contractor* shall make any modifications requested / marked-up and re-submit the revised documentation within '*the period of reply*' on the Contractor Documentation Schedule (CDS). Queries regarding comments / changes should be addressed with the *Project Manager* prior to re-submittal.

Any re-submittals, which have not included the changes / comments identified, will be marked with the applicable review code and returned to the *Contractor* to be corrected and re-submitted. The *Contractor* shall re-issue the revised documentation incorporating all comments on a new revision and other specified details not included in the previous issue within '*the period of reply*' of receipt of the marked-up documentation.

All revised data shall be submitted in its entirety and shall reflect the revision control numbers, and shall also indicate which documentation the revised documentation supersedes, if applicable.

In the case of drawings every sheet has its own revision number and is revised as an individual document.

In the case of documents all sheets under cover of one document number shall be under the same revision number and be re-submitted, even if the revision is a minor one.



Note: If hardcopy, check electronic system for latest revision

10. As-Built / Final Documentation

This is Certified 'As-Built / Final Accepted' documentation or documentation for which no further review is required. The final documentation shall form part of the final *Contractor* Manual(s) or Data Packs

Contractors shall provide the 'As-Built' documentation that form part of the Operating, Instruction and Maintenance Manuals that were issued and accepted prior to 'As-Built' conditions for inclusion in these types of manuals by the *Project Manager*.

10.1 Definition of Final and As-Built Status of Documentation

10.1.1 "Final" Documentation

This applies to "As Manufactured and Delivered to Site".

Documentation submitted subsequently by the *Contractor* once "Final" status is reached shall be indicated as such in the Revision Notes Block as "Final" and shall also reflect the New Revision Number on the document in the revision block provided.

10.1.2 "As-Built" Documentation

This applies to "As Constructed or As Installed".

The Contractor Documentation Schedule (CDS) shall indicate the documents which are to be brought to "As-Built" status, and must be submitted only after practical completion when the documentation qualifies for "As-Built" status, and the period after completion by which they must be finalized.

10.2 Preparation of As-Built Documents

10.2.1 Transnet Capital Projects Documents

The *Contractor* responsible for completing the construction / installation works shall prepare three (3) marked up hard copies of the applicable documents to represent the As-Built condition(s). The mark-ups shall be in RED pencil or pen and be complete and accurate.

Once prepared the As-Built mark-up documentation is transmitted to Transnet Capital Projects for updating of the original design documentation.

Documents / drawings updated with information known by the *Project Manager* and as provided by *Contractors* at the completion of their *Contracts* is utilized by the *Project Manager* to update Engineering Deliverables / drawings to this status, i.e., "For Record Purposes".

Note:

File naming convention on drawings / documents shall be in accordance with the Project numbers assigned on the Contractor Documentation Register (CDR).



Note: If hardcopy, check electronic system for latest revision

10.2.2 Design, Supply and Install Contractor Documents

Contractors responsible for the design, supply and installation of equipment are responsible for producing As-Builts of their own documentation.

The *Contractor* shall prepare three (3) marked up hard copies of the applicable documents to represent the As-Built condition(s). The mark-ups shall be in RED pencil or pen and be complete and accurate.

Once prepared the As-Built mark-up documentation is transmitted to the *Project Manager* for Approval through the normal process. Once approved C1 the *Contractor* can proceed to update his drawings and submit as part of the final package

The mark-ups are returned to the *Contractor* so that they can produce the As-Built revisions.

11. Installation, Maintenance and Operating Manuals and Data Books

These shall be supplied by the *Contractor* as manuals in an A4 hard covered, red, grease and waterproof binder using two (2) ring type binders.

Drawings and charts larger than A4 shall be folded and those greater than A3 shall be enclosed in an A4 plastic pocket of adequate strength.

Manuals shall be well indexed and user friendly. Manuals shall include a summarized Table of Contents and in manuals comprising a number of files / volumes there should be one summarized Table of Contents in each of the files / volumes. The draft Table of Contents shall be submitted for review to the *Project Manager* prior to the compilation and official submittal of the manuals. The technical content of manuals shall be specified by the *Project Manager*.

The originals of all brochures shall be issued to the *Project Manager*. When a general brochure is applicable to a range of equipment, then the specific item, catalogue number or model number shall be stated, which is best achieved by introducing a separate index page, which cross-references the specific item to a tag number.

The address, phone numbers, fax numbers and reference numbers of all *Sub-Contractors* shall be provided.

Where manuals include drawings that still need to be revised to "As-Built" status, and such manuals are required prior to 'As-Built' status, the manual will not be considered to be in its final form until the "As-Built" version of each such drawing has been incorporated.

The required number of copies of the manual(s) shall be as specified by the *Project Manager* and submitted per type or model number of equipment included in the contract, or as specified by the *Project Manager*.



Note: If hardcopy, check electronic system for latest revision

A typical example of what the binder / file(s) shall be marked with on the spine and the front cover is as follows: -

- Project Name
- Manual Title, e.g., Installation, Maintenance and Operating Manual
- FBS No. and Title
- Manual Numbering (e.g., Volume 1 of 2, etc.)
- Contract Number
- Contractor Name

12. Cancelling and Superseding Documentation

The Document Control Procedure for cancelling and superseding is as follows:-

12.1 Superseding

If the document / drawing has been transmitted anywhere and is to be replaced by a different document number / drawing number, then it is superseded. The superseded item should go up a revision and always have the new drawing or document number written across it, as the normal practice.

The Document Controller is to check that this has been done on the drawing or document, and the revision title block should be preceded with:-

- e.g. "SUPERSEDED by 222057-2-211-M-GA-0030"

12.2 Cancelling

If the item is to be cancelled, it means the item has been previously transmitted and it is not being replaced by another drawing number / document number. In this case the Document Controller should check that the revision has gone up, the word "CANCELLED" is written across the drawing / document and the word "CANCELLED" is placed at the beginning of the revision title block

13. Records

All documents generated in terms of this standard are to be retained by Transnet Capital Projects as records in accordance with the requirements of Project Procedure DOC-P-0013.



Note: If hardcopy, check electronic system for latest revision

Annexure A – Typical Transmittal Note



Document Transmittal Note

TO : _____		DATE : _____		
LOCATION : _____		FROM : DOCUMENT CONTROL		
ATTENTION : _____		ORIGINATOR : _____		
		PROJECT No : _____		
		TRANSMITTAL NO. : _____		
PURPOSE OF ISSUE <i>(indicate with an "X" in the appropriate block)</i>				
<input type="checkbox"/> APPROVED FOR CONSTRUCTION	<input type="checkbox"/> FOR APPROVAL	<input type="checkbox"/> AS - BUILT		
<input type="checkbox"/> APPROVED FOR DESIGN	<input type="checkbox"/> FOR INFORMATION ONLY	<input type="checkbox"/> FINAL HANDOVER		
<input type="checkbox"/> FOR TENDER PURPOSES / ENQUIRY	<input type="checkbox"/> FOR REVIEW / COMMENTS	<input type="checkbox"/> OTHER (please specify)		
<input type="checkbox"/> FOR CONTRACT / PURCHASE / SERVICES	<input type="checkbox"/> RETURN OF DOCUMENTATION			
ADDITIONAL REMARKS BY ORIGINATOR <i>(if applicable)</i>				
DOCUMENT NUMBER	REV.	DESCRIPTION	COPY QTY	FORMAT E or H
DISTRIBUTION :			E = Electronic H = Hardcopy	
NAME				
Sent by : _____		Received by : _____		Date : _____
Signature : _____		Signature : _____		
PLEASE CONFIRM RECEIPT BY SIGNING ONE COPY OF THE TRANSMITTAL AND RETURN TO DOCUMENT CONTROL AS SOON AS POSSIBLE				

DOC-TMP-0003 Rev.02



Note: If hardcopy, check electronic system for latest revision

Annexure B – Typical Example of CDR (can be supplied electronically)

TRANSNET							
TRANSNET CAPITAL PROJECTS							
Project Number: _____							
Contract Number: _____							
Register Document Number: _____							
TCP Document Number	Document Title (Description)	Contractor's Document number	Rev	Forecasted Submission date	Actual Submission Date	For-mat	Reason for Issue



H & S MANAGEMENT PLAN

HEALTH AND SAFETY MANAGEMENT PLAN

For: Transnet Port Terminals (TPT), Saldanha

Project Name: FEL3 - Saldanha Bulk Terminal Equipment Refit: Stacker Reclaimers, Ship Loaders and Tippler 2 (Phase-4: Stacker Reclaimer 3)

Project Number: Z.5200160

Author: Tanja Van Zyl
Owner: Louis de Toit (Terminal Manager)
Client: Transnet Port Terminals (TPT)
Project Sponsor: Andiswa Dlanga (Managing Executive)
Project Manager: Graham Handley

Revision Number: 01
Approved by: Werner Labuschagne (SHERQ Manager)

Document No: Z.5200160-HSMP

DOCUMENTATION DISTRIBUTION, REVISION AND APPROVAL HISTORY

REVISION NUMBER	DATE	DISTRIBUTION	PREPARED BY	REVIEWED BY	APPROVED BY
00	24/03/2020	1	T. Van Zyl	G. Handley	W. Labuschagne
01	29/06/2021				

SIGNATORIES:

Prepared by:



Tanja Van Zyl
SHERQ Officer

01-07-2021

Date

Reviewed by:



Graham Handley
Snr. Project Manager

30/06/2021

Date

Approved by:

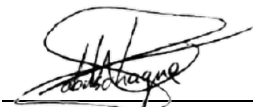

Werner Labuschagne
TPT SHERQ Manager

01/07/2021

Date

Table of Contents

1. Introduction.....	7
1.1 Purpose and Scope	7
1.2 Safety Management Principles	7
1.3 Integrated Management System Commitment Statement	8
1.4 Project Safety Goals	8
1.5 Plan Objectives	8
1.6 Relationship between Project Health and Safety Documents	9
2. Leadership and Commitment	10
2.1 Intent	10
2.2 Leadership	10
2.3 Commitment.....	10
2.4 Roles, Responsibilities and Accountability	11
2.4.1 TPT Project Manager	11
2.4.2 TPT Project Management Team.....	11
2.4.3 TPT Project Construction Managers.....	11
2.4.4 TPT Project Safety Discipline Lead	12
2.4.5 TPT Project SHEQ Manager.....	12
2.4.6 Contractor/Service Provider Safety Officer	12
2.4.7 Client Health and Safety Agent	12
2.4.8 TPT Project SHEQ Officer	13
2.4.9 Contractors' General Requirements for Health and Safety	14
2.4.10 Contractors' Management.....	14
2.5 Legal Requirements.....	14
2.5.1 Local Legal Requirements	14
2.5.2 Clients Agent.....	15
2.5.3 Documented Procedures	16
2.5.4 Document Control	16
Involvement, Communication and Motivation	17
2.6 Intent	17
2.7 Involvement.....	17
2.7.1 Incentive Program	17
2.8 Communications	17
2.8.1 Project Site Safety Review Committee (Steercom)	17
2.9 Contractor Monthly Meeting.....	18
2.9.1 Weekly Toolbox Meetings.....	18
2.9.2 Pre Start Safety Briefings.....	18
2.9.3 Employee Health & Safety Representative.....	18
2.9.4 Safety Bulletins and Alerts	18
2.9.5 Safety Action Meetings	18
2.10 Motivation.....	18
2.10.1 Site Rules	18
2.10.2 Health and Safety Disciplinary Procedure	20
2.10.3 Management –Safety Observations and Coaching (SOC's)	20
3. Performance Tracking and Accountability	21



3.1	Intent	21
3.2	H&S Performance Reporting	21
3.2.1	Lead Indicators.....	21
3.2.2	Lagging Indicators.....	21
3.3	Workplace Observations and Audits.....	22
3.3.1	Corporate Governance Audit	23
3.3.2	Pre Tender Contractor Site Audit.....	23
3.3.3	Pre-Mobilization Contractor Safety Management Plan Audit	23
3.3.4	Risk Assessment Reviews	23
3.3.5	Equipment Audits	24
3.3.6	Measurement and Review	24
3.3.7	Contractors and Vendors	24
3.3.8	Reporting.....	24
4.	Contractor Safety Alignment.....	25
4.1	Intent	25
4.2	General	25
4.3	Suppliers and Contractors	26
4.3.1	Contract Strategy	26
4.3.2	Tender Documents.....	26
4.3.3	Tender Safety Evaluation.....	27
4.3.4	Pre-Award Meeting	28
4.3.5	Award	28
4.3.6	Pre-Mobilization (Kick-off) Meeting.....	28
4.4	Employment Process	29
4.4.1	Mobilization	29
4.4.2	On Site	29
4.4.3	Review and Close Out	30
4.5	Procurement	30
4.5.1	Requisitioning.....	30
4.5.2	Inspection Release.....	30
5.	Learning and Competency	31
5.1	Intent	31
5.2	Learning	31
5.2.1	Inductions.....	31
5.2.2	Contractor's Training Programs	32
5.3	Competency.....	32
5.4	Contractors/Service Providers Safety Training.....	32
6.	Hazards and Risk Management.....	33
6.1	Intent	33
6.2	General	33
6.2.1	Technical and Construction Expertise	34
6.2.2	Hierarchy of Control	34
6.3	Top Down Planning.....	34
6.4	Hazard Management on Site	35
6.4.1	Project Specific Hazards.....	36
6.4.2	Risk Assessments (RA's).....	36
6.4.3	Daily Safe Task Instructions (DSTI's):	36

6.4.4	Planned Task Observations (PTO)	36
6.4.5	Hazard and Facility Review Studies	37
6.4.6	Hazard Identification and Risk Assessment Workshops	37
6.4.7	Risk Assessment of Plant and Equipment	37
6.4.8	Standard and Performa Registers	37
6.4.9	Method Statement	38
6.4.10	Critical Hazard Management Plan	38
6.4.11	Risk Assessment	38
6.4.12	Unsafe Operations	38
6.4.13	Work in Operating Areas	38
6.4.14	Hazardous Materials	39
6.4.15	Management of Change	39
6.4.16	Construction Regulation	39
7.	Occupational Health and Hygiene	39
7.1	Intent	39
7.1.1	Health and Hygiene Program	40
7.2	Fitness for Work	40
7.3	Hazardous Substances	40
7.4	Noise and Vibration	41
7.5	Personal Hygiene	41
7.6	Protection of Outdoor Workers	41
7.7	Occupational Health Services on Site	41
7.8	First Aid	42
7.9	COVID 19	42
7.10	Off Loading Vehicles	42
8.	Safe Systems of Work	42
8.1	Intent	42
8.2	Project Safety Standards	42
8.3	Project Safety Procedures	44
8.4	Permits to Work (PTW)	44
8.4.1	Personal Protection	45
8.5	Public and Company Personnel Safety	45
8.6	Pre-Commissioning Safety Review	46
8.7	Commissioning Safety Study	46
8.8	Detailed Requirements	47
9.	Incident Management	47
9.1	Intent	47
9.2	Incident Management	47
9.2.1	Incident Reporting	48
9.2.2	Incident Investigation	48
9.2.3	Incident and Investigation Reports Review	48
9.3	Injury Management	48
9.4	Emergency Preparedness and Response	49
10.	Designing for Safety and the Environment	49



10.1	Intent	49
10.2	Designing for Safety.....	50
10.2.1	Hazard Assessment during Design.....	50
10.2.2	Hazard Register	50
10.2.3	Design Phase SAFETY Risk Management Milestones	50
10.2.4	Management of Change	51
11.	Appendices	51
11.1	Appendix A – IMS Commitment Statement	51
11.2	Appendix B - Specific Health & Safety Specification Z.5200160-SSHSS	51
11.3	Appendix C – Baseline Risk Assessment.....	51
11.4	Appendix D - Client Safety Agent Appointment.....	51
11.5	Appendix E - Construction Work Permit	51

1. Introduction

This plan will be a live document with necessary updating to reflect project phases and developments.

1.1 Purpose and Scope

The purpose of this Health and Safety Management Plan (HSMP) is to outline the management approach and strategies to be adopted during the execution of the equipment refit in the Bulk Terminal Saldanha by Transnet Port Terminal's Project team, Principal Contractors and Contractors to prevent occupational injury or illness by anticipating, recognising, evaluating and controlling safety hazards to alleviate unsafe acts.

The Health and Safety Plan and associated contract; legislation; codes of practice; standards; procedures guidelines; programs and references (Project Safety Management System) identify and encompass the working behaviours and safe work practices that will be expected of all the Project Management Team members, Vendors and Principal Contractors; Contractors and visitors engaged on all the projects managed by the TPT Project Team.

The TPT Project Team approach to achieving this goal is based on the belief that the essential ingredients of successful safety management are:

- Dedicated managerial leadership
- Employee involvement and ownership
- Effective management systems
- Safe systems of work
- The use of principal contractors and contractors who can demonstrate that they understand these "essential ingredients" and have implemented them, resulting in acceptable safety performance; and
- By encouraging all participants in the Project to adopt a culture of exemplary safety leadership, promotion and awareness, and rigorous hazard identification and risk management

Within this Plan, the word "safety" is taken to include occupational health and hygiene and workplace safety. Also, "Contractors" is taken to include Suppliers with an on-site installation / supervisory role.

Also within the Plan the word "shall" indicates a mandatory Project requirement.

1.2 Safety Management Principles

The safety management principles adopted here in are a customisation/utilisation of the following:

- TPT Safety, Health, Environmental and Quality (SHEQ) Policy

-
- Transnet's Integrated Management System (TIMS) policy and procedures, Guidance notes and Programs
 - Legislative Requirements

It is a pre-requisite for all contractors and suppliers with an on-site installation / supervisory role to develop, operate, and maintain a Safety Management Plan which incorporates the principles outlined herein and which is tailored for their scope of work, this plan must be in accordance with the Client project health and safety specification. These Plans shall identify the key areas affecting safety and shall promote safety through design; work methods; education; encouragement and reward.

1.3 Integrated Management System Commitment Statement

The IMS Commitment Statement establishes principles to protect and advance the Projects essential safety interests and to fulfil the Project's commitment to Health and Safety. TPT highly values the health and safety of employees, customers and communities.

IMS Commitment Statement, attached as **Appendix A**.

1.4 Project Safety Goals

TPT has set a goal of "Zero Harm" to people; plant; the environment and community in the delivery of the projects. To achieve this goal, the key stakeholders in the TPT; contractors; vendors; and the workforce shall work together to demonstrate visible leadership and proactive communication to achieving safety excellence through personal examples and to promote, and provide systems where this is championed by everyone.

TPT will set key objectives and take action to achieve the goals. Goal setting will help establish priorities, build team confidence, provide direction and create motivation towards action.

The key principles that TPT will use are:

- Goals are the end towards which effort is directed
- Plans shall contain goals that aim to achieve the principles of the Project Health and Safety Policy; and
- Strategies and activities are specifically designed to achieve these goals

1.5 Plan Objectives

The objectives of the Health and Safety Plan are:

- To provide the overall approach to safety that is to be undertaken by appointed Contractor/Service Provider on the Project.
- To set the performance requirements of TPT or compliance with the Project Safety Policy
- To establish the relationship between this Safety Plan; the Contract Documents; Project Site Standards; Safe Work Procedures and Safety Plans and Programs prepared by contractors; and

- To establish actions and responsibilities that will ensure implementation of the objectives

1.6 Relationship between Project Health and Safety Documents

As mentioned previously this Health and Safety Plan describes the strategies that, together with the contract documents, will be used by TPT to implement the Project Safety Policy for all works associated with the project.

Site contractors and selected vendors shall be required to prepare their health and safety plans for executing their particular work packages on the Project. The standard set by this plan will be the minimum requirement for all contractors and vendors on the Project. All Project participants shall be made aware of the Project SHE Policy and shall be required to commit to the implementation of the Policy in their contribution to the Project.

Prior to any site work activities commencing, TPT and Contractors shall meet in a pre-start safety review. The purpose of this review will be to compare the contents of the contractors' health and safety plans and the Project Health and Safety Plan to ensure conformance to the safety approach on the project.

Contractors shall not commence work on site until they have submitted their Contract Specific Health and Safety Plan and Safety File. The Safety File, with proof of site specific RISK Induction, signed by all involved, including sub-contractors and employees reporting to specific Principal Contractor. A hard copy "Safety File" will be kept at the Port of Saldanha TPT SHEQ Offices for the duration of the project.

2. Leadership and Commitment

2.1 Intent

Leaders at all levels shall demonstrate, by means of their actions, attitude, consistency and energy provide a visible, pro-active and demonstrated commitment to Health and Safety.

2.2 Leadership

TPT will provide leadership in achieving the highest attainable standards in safety. The following embody TPT Project Team underlying values:

- We are all responsible for safety and take action to prevent harm
- We never accept or condone sub-standard work practices or plant
- Sustain a positive proactive culture where the safety will not be compromised
- Provide a healthy and safe working environment by striving to identify and eliminate workplace hazards
- Promote the assessment of risks and the elimination of fundamental causes that result in losses
- Meet or exceed all applicable legislative requirements
- Engage employees in safety management through involvement and consultation
- Encourage and support Safe Work Behaviours
- Make all levels of management individually accountable for managing safety issues
- Induct and train employees and contractors so that they are aware of and work in accordance with this Health and Safety Plan; and
- Sustain a continuous improvement focus by regularly monitoring, auditing and reviewing safety objectives and safety performance

TPT Project Team will consult with successful vendors, contractors and their personnel in order to ensure they commit to the same safety goals.

2.3 Commitment

Visible commitment is essential to providing a safe work environment. TPT Managers, Supervisors and Employees at all levels will demonstrate their commitment and concern by:

- Ensuring that decisions and practices are consistent with the stated policies, values and project objectives
- Adopting a risk management approach to all safety issues
- Participating in hazard identification, risk studies and risk assessments
- Wearing the correct personal protective equipment

-
- Putting safety first on all activity agendas
 - Participating openly in safety meetings
 - Following up on safety action items in a timely manner
 - Ensuring that all incidents are reported and investigated
 - Being part of incident investigation teams if needed
 - Participating in regular safe behaviour observations; and
 - Participating in regular inspections and audits

TPT will consult with successful vendors, contractors and their personnel in order to ensure they show the same commitment to safety.

2.4 Roles, Responsibilities and Accountability

2.4.1 TPT Project Manager

The Project Manager is responsible and accountable for the successful and safe completion of the Project.

The Project Manager must not allow any work to commence without proof of induction and proof that all the requisite SHEQ documents have been approved or signed-off before any work may commence. Owner of the Project must issue Permit to Work.

2.4.2 TPT Project Management Team

Each person in the Project Management Team has responsibilities for the management of safety. The Project Health and Safety Discipline Lead and Safety Officers have supporting roles to assist managers and supervisors fulfil their responsibilities and accountabilities. All Project Management Team members will acknowledge their safety responsibilities in writing.

2.4.3 TPT Project Construction Managers

The Construction Managers will have particular responsibilities for the management of safety on the various Project sites. The Construction Managers, have the following obligations:

- Implement the health and safety management system
- Monitor compliance to the established safety management system
- Ensure risk is at an acceptable level
- Ensure contractors' workforce and the Contractors' Construction Management Team are competent.

Provide for:

- Planning, organisation, leadership and control
- Particular technical competencies for critical work

-
- Supervision and control on each shift
 - Regular monitoring and assessment: and
 - Workplace inspections

2.4.4 TPT Project Safety Discipline Lead

- Planning, organisation, leadership and control
- Monitor compliance to the established health and safety management system
- Guide and provide support to the site safety team
- Compile procedures and ensure implementation thereof
- Audit the various sites

2.4.5 TPT Project SHEQ Manager

- Review contractor SHEQ file for accuracy, consistency and legal compliance
- Ensure that the project is audited by the Contractor/Service Provider as per their schedule
- Approve Permit to Work upon satisfaction of the contents of the document
- May request external audits if the need arises.

2.4.6 Contractor/Service Provider Safety Officer

- Conducting Site inspections
- Monthly audits
- Incident investigation
- Monitor compliance to the established safety management system
- Ensure compliance with any other relevant acts, regulations and standards

2.4.7 Client Health and Safety Agent

An OHS Safety Agent has been appointed i.t.o. Construction Regulation 5 of OHS Act 85 of 1993 and CR (Construction Regulations) 2014. The OHS Safety Agent is registered with SACPCMP as a Professional Health and Safety Agent. Refer to Appendix D for Appointment Letter and Registration Certificate.

A project specific Health and Safety Specification has been developed by the Safety Agent, in line with Transnet's Integrated Management System (TIMS) policy and procedures. This H&S Specification will be included in the enquiry documentation, as the Specification to which the Contractors are to comply. Refer Appendix B for this specification.

The OHS Safety Agent will in the appointed capacity ensure that the following stipulations in terms of the Occupational Health and Safety Act, Act 85 of 1993 and specifically the CONSTRUCTION REGULATIONS 2014 be complied with at all times within the area of jurisdiction:

- a. Prepare a documented health and safety specification for the construction work and provide any principal contractor with the same (completed).
- b. Provide the principal contractor and his or her agent with any information which might affect the health and safety of any person at work carrying out construction work.
- c. Appoint each principal contractor in writing for the project or part thereof on a construction site.
- d. Ensure that each principal contractor's health and safety plan is implemented and maintained on the construction site: Provided that the steps taken, shall include periodic audits at intervals mutually agreed upon between the client and principal contractor, but at least once every month.
- e. Stop any contractor from executing construction work which is not in accordance with the principal contractor's health and safety plan contemplated in sub regulation 5 (1)(q) for the site or which poses to be a threat to the health and safety of persons
- f. Ensure that where changes are brought about, sufficient health and safety information and appropriate resources are made available to the principal contractor to execute the work safely
- g. Ensure that every principal contractor is registered and in good standing with the compensation fund or with a licensed compensation insurer prior to work commencing on site
- h. Ensure that potential principal contractors submitting tenders, have made provision for the cost of health and safety measures during the construction process
- i. The agent shall discuss and negotiate with the principal contractor the contents of the health and safety plan contemplated in sub regulation 5(1) and thereafter finally approve the health and safety plan for implementation

The scope of the OHS Safety Agent will be applicable to all activities of employees on the construction site.

2.4.8 TPT Project SHEQ Officer

- TPT SHEQ officer will review contractors SHEQ file for consistency after obtaining a copy from the Engineering Consultant's safety officer.
- TPT SHEQ officer and the Engineering Consultant's safety officer will communicate regularly for alignment
- TPT SHEQ officer will induct the Engineering Consultant's construction team, Contractors construction team and any other visitors to the Project.
- TPT SHEQ officer may attend contractor progress meetings

-
- TPT SHEQ officer may accompany the Engineering Consultant's safety officer during inspections.
 - TPT SHEQ officer to ensure contractors comply with the HS plan.
 - TPT SHEQ officer to monitor compliance to the established safety management system.

2.4.9 Contractors' General Requirements for Health and Safety

Contractors will be solely responsible for carrying out the works under the various contracts having the highest regard for the health and safety of all personnel engaged on the Project.

2.4.10 Contractors' Management

Contractors' management personnel are responsible and accountable to the Engineering Consultant's for safety performance and have the following key responsibilities for safety management, which shall be defined in the Contractor's Safety Plan:

- Preparation, implementation and maintenance of a Health and Safety Plan specific to their area of work and responsibility
- Participate in a pre-site safety review with TPT
- Ensure that all members of the Contractors workforce have clearly defined responsibilities for safety, and that the responsibilities are clearly communicated to them, understood and fulfilled by them
- Ensure that all of the Contractor's activities comply with the requirements of their health and safety plan and relevant statutory and contractual requirements
- Establishing an on-going system for training and assessment of skills and competence
- Provision of weekly/monthly safety statistics to TPT Safety Discipline Lead
- Hazard identification and management program
- Submission of weekly Safety Observations and Conversations (SOCS)

These requirements will be further detailed in the Project Health and Safety Specification.

2.5 Legal Requirements

2.5.1 Local Legal Requirements

- Acts and Regulations and Codes
- Occupational Health and Safety Act 85/1993 (and regulations including Construction Regulations 2014)
- Nuclear Energy Act 13/1993
- Compensation of Injuries and Diseases Act. 133/1993
- Hazardous substance Act 15 of 1973
- Any other legislation as detailed in the Project Legal Register

2.5.2 Clients Agent

For the Project, the TPT's Project Manager will assume the role of Agent to the Client under the Occupational Health and Safety Act 85/1993 and Regulations. As such, the TPT Project Manager shall:

- Provide and demonstrate to the Client a suitable and sufficiently documented health and safety plan that will form the basis of a project specific health and safety specification
- Prepare and document a project specific health and safety specification for inclusion in all enquiry documents for contracts with a construction component
- Take reasonable steps as are necessary to ensure co-operation between all contractors to enable each of those contractors to comply with the provisions of the above regulations and health and safety specification
- **Be responsible for the following in order to ensure compliance with the provisions of the above Act:**
 - To provide on behalf of the Client, to any principal contractor who is making a bid or appointed to perform construction work for the Client, with the project specific health and safety specifications;
 - To ensure that TPT Project Manager appoints each principal contractor in writing for the part of the project on a construction site
 - To take reasonable steps to ensure that each principal contractor's health and safety plan is implemented and maintained on the construction site: Provided that the steps taken shall include periodic audits at intervals mutually agreed upon between the Client's Agent and principal contractors but at least once every month
 - To stop any principal contractor or contractor from executing construction work, which is not in accordance with Client, principal contractor's and/or contractor's health and safety plan for the site or which poses a threat to the health and safety of persons
 - To ensure that where changes are brought about to the design and construction, sufficient health and safety information and appropriate resources are made available to the principal contractors to execute the work safely
 - To ensure that every principal contractor and contractor is registered and in good standing with the compensation fund or with a licensed compensation insurer prior to work commencing on site; and
 - To ensure that potential principal contractors submitting tenders have made provision for the cost of health and safety measures during the construction process
 - Discuss and negotiate with the principal contractors the contents of the principal contractor's health and safety plan, and shall finally approve that plan for implementation on behalf of the Client.
 - Ensure that a copy of Project health and safety plan, as well as the principal contractors' health and safety plan is available on request to an employee, inspector, contractor or the Client.

-
- Hand over a consolidated health and safety file to the Client upon completion of the construction work and shall in addition to the documentation provided by the principal contractors include a record of all drawings designs, materials used and other similar information concerning the completed structure/(s).
 - Ensure a comprehensive and updated list of all the principal contractors and contractors on site accountable to the principal contractor, the agreements between the parties and the type of work being done is available.
 - Not recommend for appointment by the Client a contractor to perform construction work unless TPT Project Manager is reasonably satisfied that the contractor that the TPT Project Manager intends to recommend, has the necessary competencies and resources to perform the construction work safely.
 - Ensure all principal contractors are informed regarding any hazard as stipulated in the risk assessment before any work commences, and thereafter at such times as may be determined in the risk assessment.
 - That the necessary health and safety specifications are prepared and made available to all concerned;
 - That only competent Principal Contractors are appointed and provided with information which may affect the health and safety of any person on the premises in question;
 - Negotiate each Principal Contractor's health and safety plan with him before it is approved, by TPT, for implementation;
 - That the above-mentioned health and safety plans are implemented and maintained – and that audits are conducted on Principal Contractors at pre-determined intervals of not more than one month;

2.5.3 Documented Procedures

Documented procedures shall be prepared to ensure compliance with the above regulatory requirements and to enable communication of the specific requirements to the Project personnel.

2.5.4 Document Control

All safety documents shall comply with the Project document control procedures.

Involvement, Communication and Motivation

2.6 Intent

Leaders at all levels shall, proactively demonstrate their commitment to Health and Safety by means of their actions, with their visible and on-going support by involving, communicating with, and motivating their team members.

Communication on health and safety management matters is one of the key elements in achieving safety compliance on the Project site. Regular structured meetings are required to ensure that effective communications occur between management and the Project workforce.

The key programs for involvement, communication and motivation on the Project will include elements shown in following table.

Table 0.1: Key Programs

Involvement	Communications	Motivation
Suggestion scheme Achievement / Award Program/ Incentive Program	Project Safety Team Contractors' toolbox meetings; Bulletins and alerts; Safety Action Notice Board	Site Rules Safety; observations and coaching; Behavioural improvement and discipline program

2.7 Involvement

2.7.1 Incentive Program

Contractors shall establish systems within their own organisation that recognise, reinforce and reward safety initiatives and desired outcomes.

2.8 Communications

2.8.1 Project Site Safety Review Committee (Steercom)

The Project Site Safety Review Committee's shall be a group representing the safety interests of the employee workforce throughout the Project at the various sites. The committee shall include the TPT Site Construction Manager and the Construction Manager from each contractor along with an employee representative from each contractor.

The Committee shall meet monthly and deal with overall site safety issues. Any day-to-day safety management issues will be addressed immediately through the site leadership structure.

The Committee is an advisory body and assists and works constructively with site management.

The Project Team and contractors' management shall ensure that Committee representatives can afford sufficient time to devote to matters related to the Committee's activities. Minutes of the meetings of the Project Safety Committee shall be communicated throughout the Project Site.

2.9 Contractor Monthly Meeting

Contractors are to conduct at least one formal safety meeting per month and must maintain appropriate records of attendance and meeting content. Such records shall be made available to the Project- and Construction Manager and the TPT's Representatives.

2.9.1 Weekly Toolbox Meetings

Weekly safety toolbox meetings are to be held by all contractors with their employees to promote safety awareness. Copies of minutes and action items arising from such meetings are to be submitted to the Project- and Construction Manager and made available for review by the TPT's Nominated Representatives.

2.9.2 Pre Start Safety Briefings

Contractors are to hold documented Daily Safe Task Instructions briefings with each work team before the start of each shift. Attendance records and brief topic notes are to be kept for auditing and record purposes.

2.9.3 Employee Health & Safety Representative

Contractors are to ensure that sufficient elected and appointed Health and Safety representatives represent all workers employed by the Contractor. Each elected and/or appointed Health and Safety Representative is required to attend an accredited Health and Safety Representatives training course at the expense of the Contractor in accordance with the provisions of the applicable legislative requirements.

2.9.4 Safety Bulletins and Alerts

Safety Alerts shall be used as the official Project-wide-communication of serious incidents and hazardous activities. Safety Alerts shall be displayed on all safety notice boards and distributed electronically where possible.

2.9.5 Safety Action Meetings

Safety Action Meetings that centre on an issue that requires action shall be conducted as required. The topic for the action meeting is manageable within a group's area of responsibility. For example, the continuous non-compliance to wearing of personal protective equipment (PPE). A project leader calls the team together, states the purpose, outlines the facts and gives a problem-solving question for discussion. The group then brainstorms ideas, selects actions and decides responsibilities and timing. Outcomes will be documented and signed by participants.

2.10 Motivation

2.10.1 Site Rules

2.10.1.1 Site Cardinal Rules

TPT Project Team will establish "Site Cardinal Rules" that shall be applicable to all personnel engaged on Site activities. A "Zero Tolerance Policy" shall be enforced for

intentional breach of the "Site cardinal Rules." Project Team shall advise the Contractor of any "Site Cardinal rules" in place prior to mobilization to Site.

Contractors shall ensure that any introduced "Site Cardinal Rules" for H&S are implemented and clearly communicated to all personnel prior to mobilization to Site. Induction training shall include instruction and assessment of "Site Cardinal Rules"

The following are indicative of breaches of "Site Cardinal Rules":

- Smoking and unauthorised ignition sources in an ignition risk area
- Not attached while working at heights
- Entering a hard barricade area
- Not signing onto a DSTI
- Fighting / horseplay
- Under the influence of Drugs / Alcohol
- Unauthorised removal or tampering with isolation tags / locks or safety devices
- No dangerous weapons allowed
- Using non-conforming plant, equipment or tools on site
- Walking or working within 2m of quay walls or open waters without wearing a life jacket
- Speeding
- Removing or catching any marine life
- Urinating in public or open spaces
- Unauthorised bypassing of standard operating procedures; and
- Blatant or continual breaches of the Project or Contractor Health and Safety Procedures
- Obey all safety signage and road markings
- Ensure all employees are medically fit for duty

2.10.1.2 Site General Rules

Continued disregard for Project Health and Safety standards, requirements or rules by personnel on the Project will result in withdrawal of site access or other disciplinary action. Contractors shall ensure all staff personnel engaged on the project observes the following general site rules:

- Obey all traffic speed limits

-
- Responsible persons on Site shall ensure that personnel who are allocated tasks are competent to perform them
 - Gambling, horseplay and fighting shall not be permitted on the Site
 - Safe access shall be maintained at all times
 - Personnel shall only take essential items, such as toolboxes, onto the Site. All such items may be subject to inspection by security personnel, both upon entering and leaving the Site
 - Equipment, tools and utilities, owned by another Contractor or individual, shall not be used without the express permission of the TPT Representative and the rightful owner of the equipment, tools or utilities.
 - Firearms and pets are not permitted on Site
 - Wear appropriate personal protective equipment at all times when working and travelling through work areas and ensure tools and materials are in a safe condition before use
 - Food shall not be stored in the working areas
 - Attend safety meetings and conduct toolbox talks
 - Conduct Planned Job Observations
 - In the event of an emergency, follow all emergency procedures both contractor and TPT specific.
 - Smoke in designated areas only;
 - Wear seat belts in vehicles and in all other relevant equipment or machinery
 - Do not use mobile phones whilst driving

2.10.2 Health and Safety Disciplinary Procedure

Where a breach of a Site H&S rule or a Contractors safety procedure is identified the Contractor shall ensure that any disciplinary action taken is in accordance with an approved procedure. In the absence of a disciplinary procedure and dependent on the nature of the breach, the process as outlined below should be used:

- first breach -verbal warning/counselling;
- second breach -written warning/counselling; and
- Third breach -appropriate disciplinary action taken.

Where a breach of an H&S rule has occurred and is considered blatant, the person's Site access may be withdrawn at the discretion of the Project Construction Manager after consultation with the relevant persons.

2.10.3 Management –Safety Observations and Coaching (SOC's)

Safety observations shall be done at least daily at each workplace on the Project site. It is preferable that the safety observation teams comprise at least two people and represent

different levels in the organisation. Safety observation forms will be completed after each observation and handed to the principal contractor safety officer.

The process will generally be along these lines:

- Plan the observation
- Ensure that all the site rules and procedures applicable to the area are followed
- Observe the task noting any sudden change or deviation from the task as you approach
- Complete a visual assessment to ensure that you and the team members are not at risk whilst in the area
- Introduce yourself to the team on your intention to conduct the task observation, open the discussion with a positive comment
- Discuss and correct any unsafe acts/conditions, if unable to correct report to the immediate supervisor for action
- Discuss any opportunities for improvement
- When safe behaviours and conditions are observed congratulate/recognise/reward the effort; and
- Complete the documentation, including signature by those observed and report any uncorrected behaviours/conditions as well as positives to the supervisor

3. Performance Tracking and Accountability

3.1 Intent

Performance Measurement and Reporting both pro-active and reactive, are to be undertaken and used in the analysis and identification of trends and risks. Results are to be provided for review and used to encourage continuous improvement.

3.2 H&S Performance Reporting

Principal contractors' are to provide accurate on-site data of safety performance while the contractor has personnel on Site. This data shall also include safety performance for each of the principal contractor's contractors. The information shall be received by the Project Site Safety Lead at 10:00 on the Thursday of each week in a contractor's formal safety report as follows:

3.2.1 Lead Indicators

- Number of Daily Safe Task Instructions completed versus required.
- Number of Safety Observation and Coaching inspections completed versus required.
- Number of Planned Task Observations completed versus required.

3.2.2 Lagging Indicators

- Actual hours worked in the week, including overtime hours

-
- Lost Time Injuries (LTI)
 - Days of work lost due to each LTI.
 - Restricted Work Cases (RWC)
 - Days of restricted work to each R WC
 - Medical Treatment Cases (MTC)
 - First Aid Cases (FAC)
 - Total Injuries (TI)
 - Classified Injuries
 - Total Disabling Injury Frequency Rate (DIFR)
 - Total incidents formally reported during the month
 - Near miss reporting
 - Any other health and safety related event

3.3 Workplace Observations and Audits

TPT Project Team will undertake a program of auditing and workplace inspections consisting of some of the following but not limited to:

- Corporate Governance
- Pre Tender Contractor Site Audits
- Pre Mobilization Contractor Health and Safety Management Plan Audit
- Project Health and Safety Management Plan Audits
- Procedural Audits
- Project Field Audits (as a minimum)
- PPE
- Electrical equipment Inspection
- Signage
- Plant and Equipment
- Emergency procedures
- MSDS Register
- Tool Box audits
- Induction
- Task Observations
- Permits

-
- Job Hazard Analysis Reviews
 - Working at Heights
 - Confined Space
 - Barricading, etc.

The Contractor/Service Provider will establish a schedule of regular systems and field safety audits, the audit conformance will be assessed by TPT's nominated representative will establish a schedule of regular systems and field safety audits, Contractor's audit conformance will be assessed as a percentage and where conformance is better than 90% it will be considered satisfactory and the contractor shall develop an action plan within four days, and implement as agreed upon between the auditor, construction manager and contractor representative and to be reviewed at the next regular audit. Where the contractor's level of conformance is between 75 -90%, a corrective action plan will be required to be developed and implemented within one week, and a follow up audit will be carried out. Where the contractor's conformance is less than 75% the contractor shall stop work until an investigation of the cause(s) has been completed and corrective actions have been developed and implemented by the contractor.

Contractors shall provide to the TPT's nominated representative, at a time to be agreed, a regular status report on all outstanding corrective actions until they are successfully closed out.

3.3.1 Corporate Governance Audit

Formal examination of the Project and Sites against the TPT SHEQ Policy, Program Elements and Expectations, and Standards.

3.3.2 Pre Tender Contractor Site Audit

An audit of a contractor workplace to assess the suitability of a contractor prior to issuing a tender.

3.3.3 Pre-Mobilization Contractor Safety Management Plan Audit

A desktop review of a contractor's project specific safety management plan against a predetermined set of criteria that has been communicated to the contractor prior to submittal of the plan.

3.3.4 Risk Assessment Reviews

Review of Risk Assessments as prepared by contractors.

Reviews are done after the following, but not limited to:

- New activities:
- Work methods change

-
- Procedures or standards change
 - Legislation change
 - Changes (Management of Change);
 - Workplace incidents
 - All risk assessments must be reviewed annually if no change

3.3.5 Equipment Audits

Detailed inspection of equipment using predetermined checklists by competent personnel.

3.3.6 Measurement and Review

- Safety performance reviews with all site personnel by their supervisors at monthly intervals
- Schedule of site inspections and audits involving persons in leadership roles
- Leadership participation and review of significant incidents
- Schedule of reviews of the Health and Safety plan implementation progress
- Schedule of external safety audits of the project
- Scheduled reviews after the completion of potentially high-risk activities on site
- Provision for monitoring of employees exposure to noise, dust etc.
- Inspection and acceptance of plant, equipment, tools etc. prior to introduction to site and regularly thereafter

3.3.7 Contractors and Vendors

All contractors and vendors will be included in the safety observation and audit program.

3.3.8 Reporting

Formal Project Monthly Health and Safety reports will include at least the following:

- Significant issues and steps being taken to overcome them;
- Projects positive performance indicators', leading and lagging indicators and associated action taken:
- Incidents / Near Misses
- LTI – Lost Time Injury
- DIFR – Disabling Injury Frequency Rate
- Safety training
- Challenges envisaged on the project
- Achievements
- MTI – Medical Treatment Injury

- 12 month rolling horizon
- First Aid
- Audits

Safety Performance Summary forms shall be completed for each week and submitted to TPT or the TPT's nominated representative no later than the first day of the following week.

Monthly Safety Performance Summary forms are to be completed by the Project team and all Project contractors.

Contractor/Service Provider Safety Department will consolidate the monthly health and safety report before or on the 27th of each month and forward a copy thereof to the TPT SHEQ Manager.

4. Contractor Safety Alignment

4.1 Intent

The contracting of services, and/or the purchase, hire or lease of equipment and materials shall not cause harm to personnel, the public, and the environment or to property. Arrangements will be in place for the safety of visitors to our operations and projects. Selection and retention of contractors and suppliers shall include review and assessment of safety performance.

4.2 General

Effective alignment of contractors' safety values and goals to the TPT's safety values and goals will be an integral part of the Project's Health and Safety Management System. A Contractors' Health and Safety Plan shall incorporate the intent of this Health and Safety Plan and will focus on key hazards and systems, as well as how the plan will be monitored and reviewed during the execution phase.

The alignment process managed by TPT & engineering Consultant's Project Team will cover the following stages in the Project Contract Strategy;

- Pre-qualification of contractors
- Pre-contract considerations
- Tender
- Tender evaluation
- Pre-award alignment
- Award
- Pre-mobilization alignment
- Mobilization

- Work On-site: and
- Review and close out

The extent and level of detail to be considered will be contract specific and will depend on:

- Services being contracted
- Size and complexity of the job
- number and experience of the workforce
- Risks and hazards associated with the works; and
- Safety program record and commitment of the contractor

Safety requirements shall be an integral part of the overall process of arranging and managing contracted work.

4.3 Suppliers and Contractors

4.3.1 Contract Strategy

The identification and definition of a contracting strategy and contractual arrangements will be developed using a systematic risk management approach in order to execute the work in a way that minimises the risk.

The safety input into the overall risk assessment will take into consideration the following factors:

- Number of contracts
- Interfaces between the contracts
- Contractual relationship between Transnet Limited, the principal contractor and other contractors
- Seriousness of potential safety consequences on the Project
- Likelihood of any dangerous consequences
- Complexity of the project as a whole
- Size and/or value of the project
- Services being contracted for
- Number and experience of the workforce; and
- Safety program, record and commitment of the contractors

4.3.2 Tender Documents

Tender documents issued to selected tenderers will include a Project Specific Health and Safety Specification, see attached Appendix B.

This specification was developed by the Professional Health and Safety Agent.

The appointed Professional Health and Safety Agent will conduct the Construction Health and Safety Baseline Risk Assessment for inclusion in the tender documents.

4.3.3 Tender Safety Evaluation

Potential tenderers will be screened to confirm that they have the necessary expertise, experience and capability to undertake the required role and that they are prepared to commit to the Project Health and Safety Plan.

The primary purpose of the tender assessment process is to achieve:

- Confirmation that tenderers have recognised the safety programs and expectations of the Project
- A thorough evaluation of each tenderers' Health and Safety Plans to ensure they achieve at least the minimum acceptable standards defined in the contract documentation
- An evaluation of each tenders ability to do the job and meet the Project's safety objectives
- An evaluation and comparison of the safety aspects in competing bids; and
- A checklist of the items to be clarified by tenderers

Screening will include:

- Contractor health and safety program questionnaire
- Evaluation of previous experience of potential tenderer
- Assessment of potential tenderers general reputation for management of health and safety during their work within industry
- Contractor health and safety policy
- Safety performance record, including any previous prosecution
- Contractor health and safety management systems and structures
- Demonstration of contractor senior management commitment to health and safety
- Specific Transnet Limited requirements
- Specific project and legislative requirements
- How nominated safety performance objectives will be met
- How contractors will meet the intent of the contract and work in with the project site culture: and
- Contractors' safety management structure

TPT Project Team will review contractors using a formal safety program evaluation checklist.

The detail required in contractor's health and safety plans will be dependent on the size, complexity and relative risk of the contract works.

4.3.4 Pre-Award Meeting

Meetings with tenderers during the tender evaluation period shall include clarification of TPT's health and safety commitment and requirements, TPT Project team and contractors site safety programs, finalise common goals reach agreement on performance requirements, meet proposed supervisory personnel, and clarify what is in the price and what is not.

4.3.5 Award

Contracts shall include all of the site safety programs for the works and any pre-award agreements. These must be available before mobilisation of contractors.

4.3.6 Pre-Mobilization (Kick-off) Meeting

TPT Project Team will hold pre-mobilisation meetings with all contractors: and cover the following health and safety aspects as a minimum;

- Commitment to health and safety
- Health and Safe work culture and project goals
- Introduction of key personnel and their responsibilities
- Review of the Scope of Work, geographic layout and work environment
- Review of expected site hazards and safety objectives
- Review of the work schedule and Method Statement to identify high-risk operations and the control measures to be implemented; and
- Review of the TPT Project Team and contractor health and safety plans and requirements, highlighting requirements and responsibilities

The pre-mobilisation meeting may incorporate a construction health and safety study done jointly by TPT Project Team and the contractor's team.

A Pre-Mobilisation Workshop will also be considered. These workshops provide orientation and team building for contractors, management/supervisory teams and the Project's Construction Management Team. Typical topics might include the following:

- Project goals
- Non-negotiable requirements
- Hazard recognition skills
- Meeting/communication skills
- Incident management
- Hazardous activity management standards e.g. working at heights, manual handling, electrical safety
- Specific legislative requirements
- Project agreements

- Project site wide procedures and programs
- Fitness for work programs

4.4 Employment Process

A clear auditable employment process will be established for contractors' workforce to ensure that personnel are competent, have appropriate qualifications, job skills, experience and specific training.

Effective processes will be established to manage this high-risk period by:

- Personnel screening
- Processes for plant inspections (or certification by third parties)
- Access control onto site
- Inductions before starting work; and
- Management of contractor interfaces and facilities such as site office locations, materials lay down areas and plant pick-up areas

4.4.1 Mobilization

A Construction Work Permit from the DoL has been obtained for the entire project (Phase 1-4), permit no. WC/2018/09/CPT 240. This permit will be updated prior to the execution of Phase 4 to include the specifics of phase 4. Refer to Appendix E for the Construction Work Permit.

A comprehensive contractor employee screening, induction and training program shall be in place. Contractors shall be required to provide evidence of specified pre-requisites for all their workers, including the following:

- Pre-requisite generic induction training
- Pre-placement Medical
- Evidence of necessary skills attainment and competency
- Reference checks of previous employment; and
- A signed acceptance to comply with the site rules

4.4.2 On Site

TPT Project Manager will ensure that health and safety management plans and programs are implemented, monitored, reviewed and improved. The primary aim is for all parties to work together as a team and provide a working environment in which Project site activities can proceed in a safe manner.

All people mobilizing to site will complete the Project's health and safety induction program before they start.

All contractors to complete permit to work before commencing with onsite work. During this permit application hand overs and signoffs will be conducted which is subjected to an on-going review.

4.4.3 Review and Close Out

The safety performance of all contractors shall be subject to an on-going review. On contract completion a safety performance close out statement will be prepared.

4.5 Procurement

In addition to specific health and safety legislative requirements and obligations for manufacturers and suppliers of plant, equipment and materials, TPT Project Manager has an obligation to ensure all equipment is provided with appropriate warnings and safeguards. A comprehensive plant and equipment audit will be conducted using the workplace audit tool.

4.5.1 Requisitioning

When developing requisitions and specifications for direct equipment and materials, the TPT Project Manager and the responsible discipline engineer will:

- Assess item for any obvious hazards
- Check item has the appropriate safeguards and approvals
- Ensure there are no better alternatives available and advise the appropriate personnel
- Consider ergonomic factors such as weight, comfort, convenience of handles and controls, noise and vibration, and clarity of instructions and warnings: and
- Compile general inquiries from other users to establish if any problems have been experienced.

4.5.2 Inspection Release

Before issuing plant, equipment or materials for use on the Project, the following checks will be made by Inspectors:

- Check item received is as specified in the Purchase Order and its attachments
- Ensure plant, equipment and materials conform to relevant statutory, standards and/or codes of practice
- Test certificates or certificates of conformance as appropriate are obtained to confirm that the item complies with project and legislative requirements
- Ensure Manufacturers Installation and Operation Manuals have been completed and submitted to TPT Project Team: and
- Certified drawings, particularly for electrical equipment are available.

5. Learning and Competency

5.1 Intent

All personnel are to be appropriately trained and competent to carry out their work in a safe and skilful manner.

All personnel engaged to carry out work on the Project must have the necessary skills and knowledge and be competent to perform the tasks for which they have been employed. Contractors and new employees will be required to furnish proof by way of licences, permits, certificates or by recognition of prior learning (RPL) or by written certification by a qualified assessor of their skills, competencies and knowledge of their work tasks.

5.2 Learning

5.2.1 Inductions

All personnel involved on the Project, except occasional or short duration visitors, shall be expected to comply with the following induction program:

- **TPT Site Induction (Client)** -All personnel must complete the TPT Site Induction prior to working on the site. The purpose will be to ensure that all personnel are made aware of and are conversant with the requirements of the Clients site rules, environmental requirements, cultural heritage and community relations
- **Contractor Job Specific Induction** -All personnel shall complete Job Specific Inductions for the contracted works prior to commencing work. These inductions will be the responsibility of specific contractors
- **Visitors** -A Visitors Health and Safety Induction program will be established at all sites explaining the site, the conditions applicable to their entry onto site and the necessary PPE they will be required to wear
- **Site Pass** -All personnel who attend and satisfactorily complete each induction shall be issued with a photo identification site pass. The site pass will record information in acknowledgment that they have attended the induction program. The site pass is to be carried on employees at all times on site.

5.2.2 Contractor's Training Programs

Contractors' training programs will include coverage of the following where relevant to individual's duties, but not limited to:

- The Project's Health and Safety Plan
- Contractors' Health and Safety Plans
- Fitness for Work
- Operating mobile plant
- Slings and moving loads and using lifting devices
- Manual handling
- Working at height
- Purpose of inspections and inspection reports
- Contractors' site specific inductions
- Confined space
- Hot work
- Pre start checks
- PPE use and training
- Excavation
- Isolation
- Scaffolding; and
- Hazardous substance handling, storage and use

At the completion of all training, competency of individuals shall be validated by the trainer. This will be by means of an examination (written, oral or practical) or an assessment of the trained person's performance during the training,

A record of safety training undertaken by each employee will be documented and retained permanently on a database and the employee's site identification and security card.

5.3 Competency

All personnel engaged to carry out work on the Project must have the necessary skills and knowledge and be competent to perform the tasks for which they have been employed. Contractors and new employees will be required to furnish proof by way of licences, permits, certificates or by recognition of prior learning (RPL) or by written certification by a qualified assessor of their skills, competencies and knowledge of their work tasks.

5.4 Contractors/Service Providers Safety Training

The TPT Project Manager with supporting documents from the Safety Agent will prepare a training matrix, to identify required modules and ensure role out for staff & contractors.

All identified personnel (principal contractors, subcontractors, EPCM, etc.) involved in the project to complete the following training courses:

Course Title	Overview	Objectives
Site Safety Awareness	Site Safety Awareness is a learning activity to help you understand safe working practices on site. Completion of this learning activity is mandatory for all staff prior to going on site, including construction sites and day visits to carry out site surveys.	Avoid accidents and ill health Be aware of the hazards you may be exposed to and how to protect yourself Meet your responsibilities towards others Meet your responsibilities towards the environment
Health and Safety Management Systems	A one day course designed to help project managers and project engineers who are involved in Health and Safety management activities. The course will inform you about the importance of Health and Safety management, management principles, and business benefits and how to overcome negative perceptions about Health and safety management. The course also covers vital definitions such as safety, hazards, risks, systems, etc. Enough time is allotted to understand and practice hazard identification and risk assessment, as well as to understand OHSAS 18001 requirements and benefits.	Where does OHSAS 18001 fit into the big picture? How a health and safety management system can improve your business. Vital safety management issues. How to identify risks and perform a risk assessment.

6. Hazards and Risk Management

6.1 Intent

All hazards to people, plant, equipment, the environment and the community are to be identified assessed and appropriate control measures, in accordance with risk management principles and Transnet's Integrated Management system (TIMS) policy and procedures. TPT has appointed a H&S Agent to facilitate this process

6.2 General

This section describes the principles of hazard and risk management that will be applied throughout the Project. Details of how the process will be implemented throughout the Project phases will be addressed throughout this Health and Safety Plan.

The five-fold hazard and risk management process will be applied throughout the project life cycle. This will involve:

- Defining the job
- Identifying the hazards
- Assessing the risk
- Controlling the risk; and
- Monitoring and reviewing the process

The principles for application of this process throughout the project will include:

- Wide spread and effective consultation; and
- Top down planning for SAFETY

6.2.1 Technical and Construction Expertise

Individuals with adequate understanding of the specific hazards, the phenomena associated with accident causation, the phenomena associated with injury causation, and the particular risk assessment process being used will be engaged in all risk management processes.

6.2.2 Hierarchy of Control

Following hazard assessment, remedial measures will be defined for situations of excessive risk. Control measures to eliminate or minimize the risk will be followed in the following order of priority:

- Firstly, try to eliminate the hazard
- If this is not possible, prevent or minimise exposure to the risk by one or a combination of:
 - Substituting a less hazardous material, process or equipment
 - Redesigning equipment or work processes
 - Isolating the hazard

(Note: These measures may include engineering methods)

As a last resort, when exposure to the risk is not (or cannot be) minimised by other means:

- Introduce administrative controls
- Use appropriate personal protective equipment

6.3 Top Down Planning

The project will adopt Top down Planning, where in the early stages of planning for work, the job process and scope will be defined in broad terms, the five-fold hazard and risk management process will be applied. The five-fold process will continue to be applied as the project is defined in more detail. This is illustrated in the following table.

Project Definition	Concept hazard list and risk assessment
Engineering	Planning and designing for Health and Safety and also to consider environmental and quality (SHEQ) issues. Hazard studies where applicable Hazard register HAZOP's
Procurement / Tendering	Specific hazards identified in tender documents and on-site inspections. Special Conditions (of contract) for Health and Safety and Quality included in tender documents Work method statements Draft contract -specific SHEQ Management Plans Contractor identified hazards and hazardous tasks for contract scope
Construction	Construction Safety Study Contract specific Health and Safety plans Preliminary Hazard Analysis Workshops Site wide SAFETY standards for Designated Hazardous Activities Detailed Work Method Statements Job Hazard Analysis Top Five Hazard Elimination Programme Safe Behaviour Observations Pre-start SHEQ meetings
Pre-Commissioning and Commissioning	Specific pre-commissioning plans Pre-commissioning risk assessment Commissioning Health and Safety Study Specific Commissioning Plans Contract specific Health and Safety Plans Preliminary Hazard Analysis Workshops Safety Standards for Designated Hazardous Activities Top 5 Hazard Elimination Program Safety Task and Behaviour Observations Pre-Start Health and Safety Meetings

6.4 Hazard Management on Site

Prior to the commencement of the work, including mobilization and site set-up activities, the contractor must demonstrate to the satisfaction of the TPT Project Manager that the contractor has performed hazard identification and risk assessment of the work, and of the associated equipment and facilities, to meet the requirements of the contract. The

contractor is responsible and accountable for ensuring that effective procedures and assessment systems are in place so as to control hazards and so mitigate risks to as lower level as is acceptable and to meet all the Health and Safety management requirements under their Contract.

6.4.1 Project Specific Hazards

The TPT Project Manager along with the TPT appointed H&S Agent has identified specific job-related hazards applicable to the Work under the Contract and has prepared a Baseline Risk Assessment, refer to Appendix C.

The Baseline Risk Assessment forms the basis of the H&S specification, refer to Appendix C.

6.4.2 Risk Assessments (RA's)

- To be completed one week before the execution of a job, and submitted to the TPT Project Manager for approval, to avoid delays.
- Each Contractor must submit a RA plan that will also include a monitoring and review plan.
- Safe Work Procedures and Method Statements to accompany RA's
- Each Supervisor to communicate Job Specific Risk Assessments to every person involved on the job, and workmen must sign acknowledgment the communication of and understanding the risks related to the job and preventative measures and controls
- Generic Risk Assessments will not be accepted
- RA Team to consist of the Contractors' Site Manager, Specific Task Supervisors, and Specialists executing the job, the H&S Agent Registered with SACPCMP, TPT SHERQ Manager and EPCM Project Manager.

6.4.3 Daily Safe Task Instructions (DSTI's):

Each Contractor's Supervisor and Foreman must, on a daily basis before work commences:

- Inspect his work area and complete the checklist part of the DSTI. Complete the DSTI regarding tasks for the shift, specific hazards and specific precautions and also refer to and discuss the precautions and controls of the relevant Risk Assessments
 - Discuss the DSTI with his team
 - The supervisor and his team must then sign the DSTI acknowledging communication thereof
- If the scope of work or job changes, the DSTI is revised and communicated before commencing with changed job.

6.4.4 Planned Task Observations (PTO)

- Each Contractors Supervisor and Foreman will complete and submit at least one PTO daily
- When sub standards are identified RA's is revised and communicated again

Discuss and rectify non-standard actions with employee.

6.4.5 Hazard and Facility Review Studies

Contractors are to conduct Hazard Identification studies and ensure that it is incorporated into the contractor's Design Management Plan and scheduled at appropriate stages of the design process.

Contractors are to make available suitably qualified and experienced personnel to participate in these studies. The TPT and/or TPT's nominated Representative will also participate. Contractors are required to provide all input data for the conduct of the studies.

6.4.6 Hazard Identification and Risk Assessment Workshops

The Contractor must conduct, with appropriate personnel, hazard identification and risk assessment workshops to identify the detailed methodology and related hazardous activities, in particular those with potentially catastrophic consequences such as multiple and single fatalities, of the contractors site installation work scope, for example crane operations and positions, lift sizes, work at height locations, confined spaces locations, work near operational plant, hot work, hazardous substances and dangerous goods being used, etc.

The Contractor are also to conduct, with appropriate personnel, Hazard Assessment workshops to identify the work methodology and related hazardous activities, in particular those with potential for fatality or serious injury, of tasks and activities related to particular work packages or locations. In all circumstances the objective of these risk management processes will be to eliminate hazards or otherwise reduce risks through the hierarchy of controls. These Hazard Assessments to be executed during tender period to provide input for contractor's Method Statements and H&S Management Plans.

6.4.7 Risk Assessment of Plant and Equipment

Risk assessments of plant and equipment are to be undertaken and documented before arrival at site and after major service, after modification, and before use in an unusual operating mode. They are to be undertaken by a suitably qualified and experienced person and to be reviewed and signed by the Contractor Project Manager or Equipment Supervisor.

6.4.8 Standard and Performa Registers

As standard project procedures, the Contractor is expected to:

- Set up an initial set of registers
- Complete the registers for each piece of plant, tool & equipment brought onto site
- Maintain a complete, continuous and comprehensive inspection & service history of these registers

Ensure at least monthly inspections are done and recorded for all plant, tools & equipment by a competent person.

6.4.9 Method Statement

Where required the Contractor must submit Method Statements to the TPT Project Manager or representative and these are to be submitted one week prior to the work commencing, or on request of TPT or the TPT's nominated Representative. The safe work procedure and risk assessment to accompany the method statement.

Acceptance of a Work Method Statement by the TPT Project Manager must not relieve the Contractor of responsibility for ensuring full compliance with Contract specifications and conditions. Specific Method Statements may also be required by legislation.

6.4.10 Critical Hazard Management Plan

Where the Contractor identifies a Critical Hazard, that is one that has the potential to cause multiple fatalities and the exposure is not an isolated occurrence, it must develop a Critical Hazard Management Plan to control the risk. This Plan is submitted to the TPT Project Manager for review and be entered in the Site Risk Register. Journey hazards to and from the Site should be included.

The plan is to be periodically reviewed for applicability and suitability.

6.4.11 Risk Assessment

As described above, prior to the commencement of each work activity or as requested by the TPT or the TPT's nominated Representative, a Risk Assessment (RA) or similar is to be completed and documented. The purpose of the RA is to identify all potential hazards associated with the Work and the Work environment, assess the risk these hazards present and then to provide risk control action that deals with those hazards, as well as providing to the workforce involved in the particular work activity, details of any hazards and the proposed controls.

The documented RA and / or resulting Work Instruction is completed by the work crew and job supervisor, and at least one team member is skilled and experienced in the risk assessment process. Completed RA's are available for review by the work crew, the TPT and the TPT's nominated Representative upon request.

6.4.12 Unsafe Operations

If the Contractor or TPT believes that the work cannot be safely undertaken or that continuance of the work may result in unsafe conditions, it must immediately cease the operation until a safe method of work has been identified. The Contractor must at all times make every effort to control or overcome the cause, or minimize the effect of, any unsafe condition.

6.4.13 Work in Operating Areas

When the Contractor is working in close proximity to operating cranes, roads, access ways or other equipment and a safety hazard has been identified, the Contractor must provide safety watchers as necessary or as directed by the TPT's nominated Representative and must provide, erect and subsequently dismantle all the required barriers, flags, wheel stops, buffer stops, flashing lights or other safety equipment to enable its operations to

proceed in a manner which satisfies the TPT's nominated Representative. At all times, defined access ways are to be kept clear of objects or obstructions which could cause injury to personnel or damage to equipment or plant.

6.4.14 Hazardous Materials

The Contractor must set out its policy for the use, transportation, handling and storage of fuel and hazardous materials taking into account the legislative requirements.

The Contractor must ensure that all hazardous materials and waste products are disposed of in accordance with applicable laws and regulations and any procedures published by the TPT or in the absence of any relevant law, regulation or procedures, in accordance with sound safe practice and by an authorized waste disposal service provider.

6.4.15 Management of Change

The Contractor must develop a Procedure and system to manage the change process. This Procedure and system must address the required processes to ensure that proposed changes do not give rise to unacceptable risk to health, safety, assets and/or the environment.

The change management process must aim to ensure the following:

- Changes are identified and recognised;
- Careful consideration is given to managing the risks associated with any change;
- Due diligence can be shown to have taken place;
- A reduction in the number of unsatisfactory or unnecessary changes;
- Involvement of the relevant people in the change process; and
- all statutory requirements are met

The change management controls must apply having regard to the fact that change may be planned, sudden or gradual.

6.4.16 Construction Regulation

In addition to the TPT Risk assessment requirements above, the contractor must implement and ensure compliance with: Construction Regulation 9 as per the latest legislation CR 2014.

7. Occupational Health and Hygiene

7.1 Intent

Provide adequate occupational health, hygiene and work place facilities and equipment to all TPT personnel and Contractors. Encourage an early return to work program for all injured employees and effectively monitor workplace hazards.

7.1.1 Health and Hygiene Program

The objective of the Project occupational health and hygiene program is to ensure that risks to health are identified and controlled. An occupational health and hygiene program for the Project will be developed and implemented and will include where appropriate:

- Pre-employment medicals which will include but not limited to a blood test and chest x-ray
- Measures against acute health disorders (e.g. food poisoning, displaced disc. etc.)
- Measures against chronic health disorders (e.g. deafness, cancer etc.)
- Recurrent health checks
- Monitoring of the working environment for health hazards
- Ensure cleaning of the employees protective clothing
- Monitoring of personnel who may be exposed to particular hazards; and
- Monitoring of the working environment will include any requirement for survey of likely health hazards such as, for instance airborne particulates, corrosive and caustic chemicals, noise and vibration, manual handling, stress and infectious disease. Cognizance of the TPT Occupational Hygiene Surveys will be required, along with any risks found during these surveys, which might impact on Contractor or TPT employees in the site.

TPT will include in their tender works information, a clause informing the Contractor to appoint a service provider for this activity.

The Program will also make references to TPT Occupational Exposure program.

7.2 Fitness for Work

The Project Fitness for Work Program will be implemented throughout the site. The program will include controlling the risks associated with:

- The consumption of alcohol
- General level of personal fitness and medical conditions
- The effect of drugs (prescription, pharmaceutical or illicit)
- Fatigue; and
- Stress

7.3 Hazardous Substances

The following rules will be implemented for the storing and handling of hazardous and dangerous goods:

- Compliance with local legislation in regard to the storage and handling of flammable and combustible liquids
- Contractors to provide a list of hazardous substances and corresponding Material Safety Data Sheet (MSDS) prior to bringing substances on Site.

- Substance register to be held at each storage facility
- Corrosive materials to be stored and handled in accordance with local requirements
- Fuel, oils and substances in containers of 200 litres or more shall be stored in a bunded area with capacity of at least 110% of stored substance.
- All fuel, oils and substances must be clearly labelled
- Transfer of bulk fuel and handling of hazardous substances shall be conducted only by appropriately trained personnel
- Spill clean-up kits including absorbent materials shall be kept at each storage facility
- Servicing, lubricating and minor mechanical repairs to vehicles and equipment shall only be undertaken in areas nominated by the TPT Construction Manager. The Contractor shall provide appropriate containers to hold waste lubricants, recycling of waste lubricants will be considered prior to disposal.
- Major machinery maintenance shall be performed in an approved workshop.

7.4 Noise and Vibration

A program for the management of exposure to noise and vibration hazards will be developed and implemented for the execution of the Project. The program will include targeted periodic surveys of noise and vibration exposure and monitoring of risk control processes.

7.5 Personal Hygiene

The Project will provide proper amenities to enable the practice of good personal hygiene including toilets; eating facilities separate from work areas; washing facilities close to the workplace and appropriate protective clothing.

Details of the Personal Hygiene Program will be developed and implemented for the execution of the Project in line with TPT Health and Hygiene programs.

7.6 Protection of Outdoor Workers

A program for the protection of outdoor workers will be developed and implemented for the execution of the Project. The program will include the control of exposure to ultraviolet radiation and exposure to heat and cold.

7.7 Occupational Health Services on Site

Details of the Project's occupational health services will be developed and implemented for the execution of the Project. The extent of the occupational health services will be determined by consideration of the occupational health hazards expected at the site, the location of the site, the expected number of people in the workforce; consultation with local medical practitioners, TPT on-site clinic, hospitals and ambulance services; and legislative requirements. The services will include the provision of first aid; on-going injury management; and health assessments and health surveillance where required.

7.8 First Aid

All First Aid injuries will be treated in the first instance by the site First Aid Officer, located on site.

7.9 COVID 19

The Service Provider to ensure full compliance to TPT COVID 19 requirements and Government Safety measures regarding preventing the spread of the COVID 19 virus.

See Appendix B – SHE Specifications

7.10 Off Loading Vehicles

Service provider must ensure that when required to off-load or load any heavy equipment and machinery on the plant that they comply with that equipment or machinery will not be physically operated by an employee when required to off-loaded or load from any flatbed or low bed.

8. Safe Systems of Work

8.1 Intent

Documented Safe Systems of Work shall be developed for all work activities and working environment conditions that have the potential to cause harm to people. Damage to equipment or effect the surrounding community or environment.

8.2 Project Safety Standards

TPT Project Team will monitor specific designated hazardous activities that shall be controlled by site wide mandatory safety standards. Contractors Work Method Statements shall be required to meet these mandatory standards for designated hazardous activities. Designated hazardous activities shall be subject to on-going review of the Project's hazard and risk profiles. The following are Designated Hazardous Activities for which Project Health and Safety Standards shall be prepared:

- Barriers and Barricading
- Change Management
- Confined Space
- Cranes and Lifting Equipment
- Heavy Lifting
- Dangerous Goods and Hazardous Substances

-
- Electrical Safety
 - Excavation and Trenching
 - Work at Height
 - Falling Objects
 - Isolation from Hazardous Energy
 - Mobile Equipment and Light Vehicles
 - Permit to Work
 - Hand Tools, e.g. grinders, power tools
 - Site Emergency Management
 - Welding, Cutting and Hot Work
 - Scaffolding
 - Steel erection
 - Respiratory protection
 - Explosive activated hand tools
 - Safe communication
 - Ergonomics
 - Housekeeping practices
 - Fire risk management
 - Hearing conservation
 - Planned Task Observation
 - Designing for safety procedures
 - Managing hygienic facilities
 - Notices and signs
 - Fire protection
 - Building and floors
 - Lighting
 - Ventilation
 - Machine guarding
 - Labelling
 - Fire equipment
 - Pressure equipment

-
- Portable electrical equipment
 - Earth leakage relay
 - Personal protective equipment
 - Storage of flammable and chemical explosives
 - Security
 - Training, awareness and competency
 - Written safe work procedure
 - Incident statistics
 - Plant and equipment maintenance
 - Health and safety risk finance
 - Incident recall
 - Health and safety target objectives
 - Health and safety representative
 - Smoking policy

8.3 Project Safety Procedures

In addition to the Project Health and Safety Standards and Procedures shall cover the following activities. Contractors Work Method Statements shall be required to meet the requirements of these health and safety procedures. The following are typical activities to be covered by Project Health and Safety Procedures:

- Incident and Injury Management
- Inductions

8.4 Permits to Work (PTW)

A Permit to Work shall be required for:

- All designated hazardous activities
- All work in designated hazardous areas
- All work where there is an interface with BTS/TPT or other operations effected.
- All hot work; and
- Any other activity assessed as having a potential for personnel injury or damage to plant, equipment or the environment

The client operational representative shall not issue a PTW unless the following have been completed:

- Identification of the hazards

-
- Isolations have been carried out and checklist completed
 - Other special permits and their requirements carried out
 - A DSTI for the task has been completed by the work team involved in the task,
 - All those involved in the task has been made aware of the hazards involved

Every person on the job shall sign on to the PTW when commencing and sign off when the job is completed or suspended.

The PTW shall only be valid for the job and conditions specified therein.

8.4.1 Personal Protection

All personnel at the various sites, including visitors, shall use the following minimum personal safety equipment at all times:

- Safety head protection with chin strap (SABS 1451 approved)
- Safety footwear with steel toe protection (Frame type or equivalent)
- Safety glasses with side shields (UVEX type or equivalent) as required
- Hand Protection as required
- Long trousers
- Long-sleeved shirts with cuffs and collars and reflective taping
- High visibility vests or shirts as required
- Suitable protective clothing (Overalls for all employees conducting physical working)
- Depending on the type of activity the following PPE is required:
- Hearing and respiratory protection as required
- Personnel exposed to noise levels exceeding 85dB (A) for any period of time or where signs indicate hearing protection is required to wear (SABS 1451 approved) hearing protection.
- Other personal protection items such as gloves, face shields, leather spats, safety harnesses, aprons or other such items may be specified for use by legislation, the Scope of Work or the Client Representative. Personal protective equipment must also be worn, if recommended by manufacturers or suppliers of proprietary products or equipment.
- All personnel engaged in maintenance and operational activities must use the minimum personal protection applicable at the site

8.5 Public and Company Personnel Safety

Public safety shall be considered and remedial actions identified and implemented when developing all Risk Assessments and DSTI's. Unauthorised persons will be prevented entry to the work site by appropriately securing all work sites at all times

Where practical, signage and/barricading shall be placed at all entrances to work sites advising all unauthorised personnel to report to the site office prior to entering the site.

8.6 Pre-Commissioning Safety Review

The TPT Project Manager, H&S Agent, Client Team and Construction Management Team will ensure that a formal pre-commissioning safety review is performed prior to start-up of the plant.

The pre-commissioning review provides a final checkpoint for the new plant, and is part of the process for ensuring that all necessary actions have been completed. The elements to be considered include:

- Construction and equipment is in accordance with design specifications
- Formal hazard analyses have been appropriately documented and communicated and are available to all personnel
- Recommendations have been addressed and actions necessary for start-up have been completed
- Documentation relevant to any changes has been created/updated
- Safety, operating, maintenance and emergency procedures are in place
- Training of operating and maintenance employees has been completed
- Mechanical integrity systems are in place (e.g. equipment tests and inspections of critical equipment, quality control procedures, and reliability engineering analysis); and
- Safety considerations are checked off

8.7 Commissioning Safety Study

The TPT Project Manager, H&S Agent, Client Team and Construction Management Team will facilitate and coordinate a formal Commissioning Safety Study and ensure that required procedures are prepared prior to commissioning of the facility.

The Commissioning Safety Study will provide a final checkpoint for the new facilities and is part of the process for ensuring that all necessary actions have been completed. The elements to be considered include:

- Mechanical and electrical integrity systems are in place (e.g. equipment tests and inspections of critical equipment, quality control procedures, etc. which will confirm that construction, equipment and materials are in accordance with design specifications)
- Formal hazard analyses for pre-commissioning and commissioning activities have been completed, appropriately documented and communicated, and are available to all personnel
- Punch-list work has been sufficiently completed so that installations are safe to apply hazardous energy
- Documentation relevant to any modifications has been created/updated
- Safe operating, maintenance and emergency procedures are in place

-
- Operating and maintenance manuals are available and training of commissioning employees has been completed
 - As Built drawings are available; and
 - A Commissioning Permit (to apply hazardous energy) is developed and implemented.

TPT Project Manager will ensure that after commissioning there is a formal documented hand over to operations and maintenance personnel and others who will be impacted by hazards that have been identified during project activities. This will involve communication of any changes to the process hazards, procedures and operating philosophy.

Safe systems of work will be established and updated throughout the Project. Safe systems of work will be subject to on-going review to ensure their effectiveness. Site-wide Permits to Work will be used as the basis of safe systems of work for specified hazardous activities.

8.8 Detailed Requirements

The Project Health and Safety Specification provide detailed requirements in relation to Safe Systems of Work and they are not repeated here, but are considered to be of the TPT Safety Management System to be implemented on the Project.

9. Incident Management

9.1 Intent

The identification, reporting, investigation and analysis of all incidents and/or accidents shall be undertaken. The development of appropriate corrective actions and the distribution of key learning's aimed at preventing recurrence, will be undertaken.

9.2 Incident Management

A Project wide procedure for management of incidents will be developed and implemented for the execution phase of the Project, taking into account the existing TPT Incident Reporting and Investigation Procedure TPT SLDT SHEQ-RS PRO 016.

All contractors will be responsible for reporting, investigating and implementing remedial actions for incidents involving their personnel. TPT Project Manager will have active involvement in most incident management processes.

The Project will maintain a database of all incidents and contractors shall provide copies of all incident reports and investigation documentation for entry into the database and audit and review purposes.

All incidents, no matter how insignificant, must be reported and investigated to prevent further similar incidents from occurring. The following incidents must be reported and investigated as minimum as per the TPT Incident Reporting and Investigation Procedure TPT SLDT SHEQ-RS PRO 016:

- Incident resulting in a First Aid Treatment to any person

-
- Incident resulting any person having to seek Medical Treatment
 - Illness or injury that results in restricted work duty or days lost
 - Incident which has or could have resulted in damage to property and/or the environment
 - Incident that had the potential to result in any of the above

9.2.1 Incident Reporting

All incidents must be reported immediately to the supervisor in charge. The supervisor will undertake an initial assessment of the incident and determine the notification process required in accordance with the Project incident management procedure.

Contractors' shall have an incident reporting system that is consistent with the Project standards and all applicable statutory requirements.

The Project Safety Discipline Lead shall have the right to designate a representative to participate in the investigation as required.

Where required by statutory requirements the Contractor shall be responsible for incident reporting to the appropriate Authority.

The contractor must immediately notify the TPT representative, of all types of incidents which occur, immediately. A flash report to be distributed to TPT within 24 hours of the incident.

9.2.2 Incident Investigation

Investigations must take place as soon as possible after the incident has occurred. The investigation team should consist out of the TPT Project Manager, H&S Agent and other identified personnel. All incident investigations are to focus on identifying the causes of the incident so that appropriate remedial and preventative control measures can be identified and implemented.

Where the results of any investigation are not completed and issued to the Project Safety Discipline Lead within 24 hours from the time of occurrence, the Contractor shall supply to the Project Safety Discipline Lead a written update every 24 hours of the progress and results of the investigation until such time as the incident report has been fully completed and issued to the Project Safety Discipline Lead as well as TPT Representative.

9.2.3 Incident and Investigation Reports Review

Upon completion of the investigation the findings and recommendations shall be distributed to the relevant crews for discussion at a toolbox meeting.

All incidents and the results of the subsequent investigation are to be tabled and reviewed at the next Project Safety Team meeting.

9.3 Injury Management

Workplace injury management including rehabilitation will be a managed process involving early provision of necessary and reasonable service. It includes suitable duties, when

practicable, to ensure the worker's earliest possible return to work, or if return to work is precluded, to maximise the worker's independent functioning.

Injury Management on the Project will meet the requirements of the Project Incident Reporting and Investigation guide-Injury Management and will include:

- Prevention
- Early Intervention
- Early Return to Work

9.4 Emergency Preparedness and Response

Emergency response plans will be prepared for construction, commissioning, and operation of the Project before each activity begins. These plans will ensure early notification of any incident.

The Project Emergency Response Plan will include the following and as per TPT IMS SLDSHEQ-SOP 013 002 Emergency Preparedness and Response Plan :

- Describe how the emergency response is initiated and how the emergency teams are activated
- Specify command, control and communications arrangements
- Identify the roles and responsibilities of all personnel likely to be at the site or the emergency or involved in the response
- Include a person nominated as the site Emergency Control Officer; and
- Identify emergency equipment available and personnel trained in its use

TPT Project Team will ensure that coordinated plans are prepared by contractors and vendors to cover all activities on the project. These plans will be prepared in consultation with TPT Project Team, contractors/vendors and local emergency services.

10. Designing for Safety and the Environment

10.1 Intent

The identification, reporting and analysis of hazards shall form part of the design process, should designs be required. Construction, maintenance, commissioning and decommissioning shall be considered during the design phase. Environmental issues as they affect the site/project shall be identified assessed and any control measures introduced shall be monitored for effectiveness.

The design phase (if applicable) will build on the hazard identification and evaluation as design progresses. Risk mitigation measures identified in the preliminary safety risk register will be used as a basis for design. The five-fold hazard and risk management process will be applied during the design process. Hazard studies will be scheduled as

appropriate for a particular work package or area of work and may include some or all of the methods covered in this section.

10.2 Designing for Safety

10.2.1 Hazard Assessment during Design

A key project design objective is to always meet the Project's Safety design criteria. Hazard analysis and risk assessment methods will be integrated into the design engineering stages. Actions will be taken so that risks of injury or damage are at an acceptable level, (ALARP) to meet the project objective of zero harm.

Designing for Safety compliance will be achieved through the application of the following sequential steps for each design package:

- Evaluate the hazards in the preliminary hazard register and develop design criteria.
- Describe the designing for health, safety, environment and community process in the Design Plan, including how the design process will eliminate or mitigate the risks associated with the hazards in the preliminary hazard register. This may include hazard studies such as HAZOPS, Control Systems Studies (CHAZOPS), Fire Safety Studies, Ergonomics Reviews and Construction Safety Studies (HAZCON).
- Update hazard identification and evaluation, which includes a detailed assessment of any additional hazards that have been identified during the detailed design phase for each design package. Any new hazards will be added to the Project's SAFETY risk register.
- On completion of the detailed design, undertake a formal design SAFETY verification process to ensure that all hazards identified during the course of the design have been eliminated or the associated risk mitigated to ALARP

Contractors and vendors with design responsibilities shall be required to incorporate an appropriate and agreed level of hazard and risk management during the engineering design phase, which will incorporate the principles of the sequential steps listed above.

10.2.2 Hazard Register

An important output of the hazard identification stages will be the production of a Hazard Register safety risk management and will act as a 'road map' for all safety risk assessments carried out in the course of the Project. Any information considered to be relevant to the operations, will be continuously updated as a live document throughout the design and which will be available for review by all Project members. This document will serve as the basis for stage of the Project and will be carried forward in the Hazard Register. The Hazard Register is an integral part of the Project Risk Management System.

10.2.3 Design Phase SAFETY Risk Management Milestones

Design phase (if applicable) safety risk management milestones will be identified and included in the project schedule. Typical milestones may include:

- Hazard studies
- Design reviews

-
- Key design and/or calculation verification
 - Resolution of identified critical hazards; and
 - Periodic review of the overall designing for safety program

10.2.4 Management of Change

The impact of design changes on safety risks will be documented and understood. All requests for changes will be reviewed and approved to ensure that all modifications are analysed systematically and implemented in a manner that does not present an unacceptable risk to health, safety, the environment or the community.

The change management process will be done in accordance with the Project Change Management Procedure.

11. Appendices

11.1 Appendix A – IMS Commitment Statement

11.2 Appendix B - Specific Health & Safety Specification Z.5200160-SSHSS

11.3 Appendix C – Baseline Risk Assessment

11.4 Appendix D - Client Safety Agent Appointment

11.5 Appendix E - Construction Work Permit



ENVIRONMENTAL BASELINE REPORT

ENVIRONMENTAL BASELINE REPORT

For: Transnet Port Terminals (TPT), Saldanha

Project Name: FEL3 - Saldanha Bulk Terminal Equipment Refit: Stacker Reclaimers, Ship Loaders and Tippler 2. (Phase-4: Stacker Reclaimer 3)

Project Number: Z.5200160

Author: Graham Handley
Owner: Louis du Toit (Terminal Manager)
Client: Transnet Port Terminals (TPT)
Project Sponsor: Andiswa Dlanga (Managing Executive)
Project Manager: Graham Handley

Revision Number: 00
Approved by: R. Viljoen

Document No: Z.5200160-EBR



DOCUMENTATION DISTRIBUTION, REVISION AND APPROVAL HISTORY

REVISION NUMBER	DATE	DISTRIBUTION	PREPARED BY	REVIEWED BY	APPROVED BY
00	21/11/2020	1	G. Handley	M. Mazubane	R. Viljoen

SIGNATORIES:

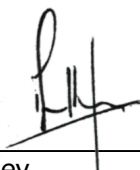
Prepared by: 

Graham Handley
Snr. Project Manager

21/11/2020

Date

Reviewed by: 

Mphilisi Mazubane
Snr. Manager

13/01/2021

Date

Approved by: 

R. Viljoen
TPT SHERQ Manager

14/1/2021

Date

ENVIRONMENTAL RISK REPORT

ENVIRONMENTAL RISK REPORT

For: Transnet Port Terminals (TPT), Saldanha

Project Name: FEL3 - Saldanha Bulk Terminal Equipment Refit: Stacker Reclaimers, Ship Loaders and Tippler 2. (Phase-4: Stacker Reclaimer 3)

Project Number: Z.5200160

Author: Graham Handley
Owner: Louis du Toit (Terminal Manager)
Client: Transnet Ports Terminals (TPT)
Project Sponsor: Andiswa Dlanga (Managing Executive)
Project Manager: Graham Handley

Revision Number: 00
Approved by: R. Viljoen

Document No: Z.5200160-ERR

DOCUMENTATION DISTRIBUTION, REVISION AND APPROVAL HISTORY

REVISION NUMBER	DATE	DISTRIBUTION	PREPARED BY	REVIEWED BY	APPROVED BY
00	21/11/2020	1	G. Handley	M. Mazubane	R. Viljoen

SIGNATORIES:

Prepared by:

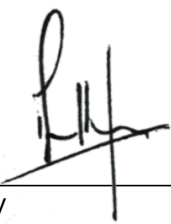

Graham Handley
Snr. Project Manager

21/11/2020

Date

Reviewed by:



Mphilisi Mazubane
Snr. Manager

13/01/2021

Date

Approved by:



R. Viljoen
TPT SHERQ Manager

14/1/2021

Date



COMMISSIONING PLAN

COMMISSIONING PLAN

For: Transnet Port Terminals (TPT), Saldanha

Project Name: FEL 3 Saldanha Bulk Terminal Equipment Refit:
Stacker Reclaimers, Shiploaders and Tippler 2.
(Phase-4: Stacker Reclaimer 3)

Project Number: Z.5200160

Author: World Crane Services (TPT Consultant)
Owner: Louis du Toit (Terminal Manager)
Client: Transnet Port Terminals (TPT)
Project Sponsor: Andiswa Dlanga (Managing Executive)
Project Manager: Graham Handley

Revision Number: 00
Approved by: K. Niemand

Document No: Z.5200160-CP



DOCUMENTATION DISTRIBUTION, REVISION AND APPROVAL HISTORY

REVISION NUMBER	DATE	DISTRIBUTION/ REVISION	PREPARED BY	REVIEWED BY	APPROVED BY
00	26/03/2021	00	WCS	G. Handley M. Mazubane	K. Niemand

SIGNATORIES:

Prepared by:

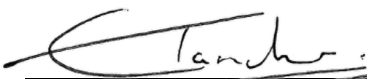
World Crane Services
Consultant

26/03/2021

Date

Reviewed by:

Graham Handley
Snr. Project Manager

26/03/2021

Date

Reviewed by:

Mphilisi Mazubane
Snr. Manager

26/03/2021

Date

Approved by:

K. Niemand
Engineering Manager

31/03/2021

Date

Table of Contents

1.	PURPOSE.....	5
2.	INTRODUCTION.....	5
3.	COMMISSIONING PROCESS.....	5
3.1	Safety during Commissioning.....	5
3.2	Tags.....	6
3.3	Lockout procedure.....	6
3.4	Commissioning Planning and Coordination.....	6
3.4.1	Principal Contractor’s Commissioning Plan.....	6
3.4.2	Commissioning Teams.....	7
4.	COORDINATION OF ALL COMMISSIONING ACTIVITIES.....	8
4.1	DAILY COORDINATION AND PLANNING MEETING.....	8
5.	PRE-REQUISITES FOR COMMISSIONING.....	8
5.1	Testing and commissioning.....	9
6.	COMMISSIONING APPROACH.....	10
7.	STAGES OF COMMISSIONING.....	11
7.1	Stage 1 – Pre-commissioning / Completion of Erection and Installation.....	11
7.2	Stage 2 – Cold Commissioning.....	12
7.3	Stage 3 – Hot Commissioning (System Integration and Load Tests).....	13
8.	PUNCH LISTING.....	15
8.1	Equipment Modifications.....	16
8.2	Safety Clearance Inspection.....	17
8.3	Statutory Certification and Approvals.....	19
8.4	Verification of Commissioning Activities.....	19
8.5	Care, Custody and Control.....	20
8.6	Spares.....	21
9.	ORGANISATION.....	21
10.	COMMISSIONING SCHEDULE.....	21
11.	SAFETY.....	21
12.	HAND-OVER PROCEDURES.....	22
12.1	Red Lining” of Commissioning Drawings.....	22
12.2	Training and Manning.....	22



12.3	Contractual Certification	23
12.4	Mechanical Completion Certificates	23
12.5	Cold Commissioning Certificates	23
12.6	Completion Certificates.....	24
12.7	Final Certificates	24
13.	RECORDS.....	24
14.	ANNEXURES	25

Annexures

Annexure 1 - Commissioning Responsibility Matrix

Annexure 2 - Commissioning File Contents

Annexure 3 - Mechanical- and Electrical Completion Certificate/RFC Certificate

Annexure 4 – Completion of Cold Commissioning Certificate

Annexure 5 - Completion/Take-over Certificate

Annexure 6 – Commissioning Team Organogram

1. PURPOSE

The purpose of this Commissioning Plan is to describe a standard approach to the commissioning management process, define the various stages of commissioning. This Commissioning Management Functional Execution Plan is directed mainly at Mechanical and Electrical Works. Structural works are subject to a fully comprehensive sampling, testing, inspection and quality control in accordance with SANS standards and procedures or best international practices including verification of dimensions and tolerances in accordance with plans, drawings and specifications and as such the commissioning of structural works are limited to the completion of punch list items.

2. INTRODUCTION

The appointed Principle Contractor will be responsible for the final detailed execution plan of the *works* and arrangements. This document gives basic guidelines of what is expected during the commissioning phase. It shall be the Principle Contractor's responsibility to complete all work as per scope, work-off all safety related punch list items, do safety checks with support of the Client's Operational Team & Commissioning Manager, sign-off completion of safety checks with client, obtain Ready for Certificate Commissioning (RFC), do Cold Commissioning with support of Client's Team, run the system and carrying out all necessary adjustments, sign completion of Cold Commissioning Certificate, do Hot Commissioning with material/Iron Ore under full operational production and proof equipment under original design load capacity. At completion of commissioning, acceptance certificate is to be completed and signed-off.

3. COMMISSIONING PROCESS

The Principle Contractor shall be responsible for organising and carrying out all the equipment tests and trials as specified in the relevant contract documents. The Principle Contractor shall be responsible to ensure that all the applicable statutory tests and design code requirements are met and that the necessary representatives of these agencies are present to witness these tests where applicable. Where the ultimate user is responsible for statutory testing and/or registration of plant and equipment, he/she shall arrange for such testing and/or registration.

3.1 Safety during Commissioning

The appointed Commissioning Manager will be in control of all Commissioning Activities: During the Commissioning phase, safety measures, to prevent the plant from being energised or being operated accidentally are of paramount importance. This is to be achieved by co-ordination of all Commissioning activities and the use of a common Lock-

Out System that will prevent people from accidentally operating isolated plant/equipment and which will, always, indicate the commissioning status of the piece of equipment being commissioned.

All personnel, whether from BTS, Transnet Port Terminals or Contractors who will be involved in the isolation and Lock-out of the plant, must be trained and appointed as "responsible persons" of the Commissioning Team. They will be tested to ensure that they have sufficient knowledge of the plant and the Lock-Out System, to carry out their duties in a safe manner, not endangering their own lives or those of other people working on the plant or put the plant itself at risk. Responsible/Appointed persons will perform their duties under the general supervision of a competent person in terms of the OHS Act, General Machinery Regulations 2.

3.2 Tags

A system of tags will be used to provide a record of inspection and checks to facilitate a systematic check out of equipment and ensure the safety of all involved.

3.3 Lockout procedure

A safe lockout procedure shall be implemented, under the control of the BTS Engineering- and Operation Managers and strictly imposed to ensure the safety of personnel engaged on the work of commissioning and start-up.

BTS to ensure sufficient Lock-out and Commissioning training are provided to ALL personnel that will be involved during the commissioning stages.

Responsibilities on permit transfer, lock-out procedures will be covered under the training and preparation for commissioning.

3.4 Commissioning Planning and Coordination

3.4.1 Principal Contractor's Commissioning Plan

The Principle Contractor shall prepare and supply a commissioning plan to cover the overall commissioning of completed work under his scope of work. This commissioning plan shall also consist of an organogram indicating all Commissioning Engineers and other staff required for the commissioning process and a detailed commissioning schedule showing all commissioning activities on a 24/7 hourly scheduled basis. This Commissioning plan shall be reviewed and approved by the TPT Project Manager.

3.4.2 Commissioning Teams

The Principal Contractor’s Commissioning Manager will take the overall responsibility for all commissioning activities. The Commissioning Manager will be assisted by a team of Engineers from all disciplines which were involved during the refurbishment execution, to make-up the Commissioning Team, with members and representatives from all departments (ECM Team, TPT projects, BTS and the responsible Principal Contractor).

The Principal Contractor shall designate representatives of his staff to assume responsibility for the complete inspection and testing of all work within the scope of his contract and to participate in commissioning activities. The Principal Contractor shall be responsible for and co-ordinate all the work of its sub-contractors. Commissioning Teams will be identified using the format shown in Table 1.

Table 1: Identification of Commissioning Teams

Commissioning Teams			
TPT Project Manager			
TPT (ECM) Commissioning Manager			
Discipline	Principal Contractor	ECM Team	BTS/ Client Eng. & Comm. Team
Mechanical	X	X	X
Electrical & Instrumentation	X	X	X
Structural/Operations			X (Operations)
QC	X	X	X
Safety	X	X	X

Refer to Annexure 6, the proposed Organogram for the Commissioning Resources.

4. COORDINATION OF ALL COMMISSIONING ACTIVITIES

4.1 DAILY COORDINATION AND PLANNING MEETING

Each morning a commissioning coordination and planning meeting will be held to review the following:

- Commissioning safety permit status, safety isolation and lock-outs, planned for the day
- Safety and new hazardous conditions
- Testing, shutdowns, tie-in's and work planned for the day
- Commissioning status and short-term forecasts
- Defect list punching and back-punching activities for the day
- Issues requiring resolution

The coordination meetings will be very brief with limited discussions. Participants will be encouraged to resolve issues immediately following the meeting and report back on the conclusions at the next morning's meetings.

These meetings will be attended by all the members representing all teams (BTS, TPT, EPCM and Principal Contractor).

The commissioning meeting may form part of the daily feedback meeting. The daily meeting will be chaired by the TPT Senior Project Manager and attended by all required stakeholders

5. PRE-REQUISITES FOR COMMISSIONING

A complete and detailed test and inspection protocol for testing of pre-assembled modules (if applicable), as well as the request for commissioning of all equipment to be commissioned, shall be submitted by the Principle Contractor for approval by TPT Project Manager, ECM Construction- and Quality Manager, before the start of testing and/or commissioning.

This test and inspection protocol shall include all tests and inspections required in terms of the respective specifications and other tests and inspections deemed necessary by the Principal Contractor to prove to the Employer's satisfaction that the equipment complies with the Works Information and must include the following where applicable:

- Signed-off Completion Certificates for all Mechanical- and EI&C Installation.

-
- Principle Contractor to apply and obtain a Mechanical Completion certificate/ "Ready for Commissioning Certificate: (RFC)
 - Pre-commissioning (Cold Commissioning) tests to be performed by the Contractor
 - Tests to prove the integrity of the safety devices, limit systems and emergency systems
 - Tests to prove the integrity of all service stops and emergency stops.
 - Complete Cold Commissioning
 - Commence with Hot Commissioning, with Iron Ore material, with support of BTS.
 - Full load tests to all mechanical- electrical- and conveyor equipment on effected route.

Functional tests

- Operational tests during Cold Commissioning, without material.
- Endurance/Proofing test of 40 hours, under full designed load for SR3 as complete operating system.
- Hot Commissioning Certificate will be signed-off and the project to be taken over by the Client/BTS on completion of endurance tests.

5.1 Testing and commissioning

BTS representatives work together with the Projects team and Contractor's commissioning team during the commissioning and testing phases.

Modules pre-assembled off site shall be trial assembled and fully tested as far as practical and be accepted by the projects team prior to delivery to site. All tests performed off site shall be repeated on completion, of refit scope of work planned for SR3, before commissioning starts, the Contractor shall satisfy himself that the installation is complete in all respects and shall carry out the necessary pre-commissioning tests.

During this period the Construction Manager will carry out visual inspections on the equipment. After approval of the test and inspection protocol by the Project Manager, the Contractor shall fully test the equipment in the presence of TPT/BTS Maintenance, Operations and Quality in accordance to the approved protocol. As far as practical the equipment shall be fully tested prior to it being Hot Commissioned.

All motions of the equipment shall be tested, during Cold Commissioning Phase, to prove correct operation and to enable position indicators and limit switches to be set, and other operational adjustments made.

Before the commencement of any tests, the Principal Contractor shall provide the initial fill of oil for all new/refurbished equipment supplied by the PC as part of their scope. Oil and grease for components supplied, to be lubricated as per OEM's/Transnet Specifications. All other existing components requiring top-up lubrication to be topped-up with lubrication, (grease and oil) supplied by BTS.

6. COMMISSIONING APPROACH

Project execution plan details the basic activities and durations to be completed and Mechanical and Electrical completion certificates to be signed off by all required parties. Commissioning Manager will then issue the Mechanical Completion Certificate/ Ready for Commissioning Certificate (RFC) before Cold Commissioning may commence.

For the detailed scope of work refer to latest Owner Requirements & Specification (Ref. Z.5200160-ORS) and the Engineering Report (Ref. Z.5200160-ER).

The commissioning for the refurbished equipment will be monitored and carried out as per agreed commissioning schedule; the table below shows the major equipment infrastructures subject to commissioning.

Table 2: Phase 4 Equipment subject to commissioning/endurance testing

Stacker Reclaimer and tripper car 3 complete System

The hours recorded for operating the entire stream will be utilised as the commissioning hours, TPT operations will be expected to provide a document indicating the hours achieved during Hot Commissioning. This document must contain the conveyor selection route and the hours recorded for each route. The hours will be added up to achieve the endurance testing objectives, which are 40hrs (either continuous or consecutive sessions) for the system operating under load.

Structural work and corrosion protection will be inspected, and data packs signed off, representatives from the Project Team must participate during inspection, and if any findings lead to the rejection of the final work, the contractor must re-visit the works information and execute the work accordingly to meet the specified quality.

7. STAGES OF COMMISSIONING

Please note: The Principal Contractor will not be allowed to proceed to Cold Commissioning until all Category A items have been resolved i.e. the plant may not be energized and run without all the safety requirements being met.

Priority Legend

Category A: Items which compromise the safety and the integrity of BTS
(Examples: Instrumentation, Start-up & Operational Control; All safety devices/pull wires; safety guards not properly installed; loose bolts; unsafe grating/access; insufficient lighting and firefighting equipment or un-grouted components etc.)

Category B: Operational requirements i.e. items which might cause operational delays e.g. spillage; belt skews; not sufficient operation personnel to commence with commissioning etc.

Category C: Items which can be completed after start up and must be completed prior to final acceptance e.g. painting; smaller adjustments not effecting the safe operation of the equipment and work that can be executed during the next scheduled maintenance window.

7.1 Stage 1 – Pre-commissioning / Completion of Erection and Installation

The Stage 1 activities are all those activities that take place prior to Cold Commissioning including Mechanical/EI&C and Physical completion ready to be subjected to functional testing, Punch listing (defect list) and completion of all Category A and B punch items. Mechanical/Mechanical/EI&C and Physical completion includes running the conveyor selection routes, flushing, hydro testing, pressure testing and other test necessary before being integrated into functional modules.

The term Mechanical Completion refers to the physical completion of work regardless of the discipline involved i.e. Physical completion of electrical instrumentation and control work is termed "Mechanical Completion".

When tests and/or checks are to be carried out to demonstrate Mechanical Completion that involves the application of energy, such as running the conveyor selection route, a safe working procedure must be developed by the Contractors and demonstrated to the relevant Commissioning Manager.

A Safety Clearance Certificate is issued after the completion of Stage 1 (a copy of which must be filed in the commissioning file and the original retained by the Contractor). In situations, such as sub stations, where no energy or livening up is required before the commencement of the Hot Commissioning, the Safety Clearance Certificate is only issued at the end of Cold Commissioning.

Depending on the contractual interfaces, more than one Safety Clearance Certificate may need to be issued for a functional entity to ensure that "user" responsibility is adequately defined and accepted.

For Structural, work where no commissioning involved, only a Completion Certificate is required once the required Punch List items are cleared.

7.2 Stage 2 – Cold Commissioning

Cold Commissioning activities are those required to bring any plant system, stream, module, unit from the status of mechanical completion to the point where Hot Commissioning may commence under the supervisory control of the relevant contractor and the issue of Cold Commissioning Certificate. This will entail running the system, Module or Unit under no load conditions and where applicable, on automatic control with stimulations as required.

Cold Commissioning activities are non-operating adjustments and cold alignment checks made by the contractor, in accordance with detailed checklists. The activities cover a very wide range and include checks on electrical, motors, control and safety systems as well as running the plant under simulated conditions without load.

Before any Unit, Module or System is energised during Cold Commissioning a Safety Clearance Certificate must be issued. Updated Maintenance Manuals to be prior to Cold Commissioning, for information to be captured into the SAP maintenance system.

No Cold Commissioning will be allowed unless the Contractor has submitted the commissioning, operating, maintenance manuals and mechanical completion certificate have been issued for the Contract Works or part thereof. Red lined "as built" drawings must be available and must be kept up to date as the commissioning process continues.

a) Testing of Individual Equipment (Units)

This stage of Commissioning consists of the complete inspection, testing and operation of each piece of equipment individually, including electrical control and power wiring which has been connected to the equipment, as well as, the checking of the configuration and

calibration of each instrumentation loop. It is the Contractors responsibility to carry out Cold Commissioning related to the Scope of work, as defined in the relevant contract, to the satisfaction of the responsible Commissioning Team. The responsible Commissioning Team will provide technical assistance where necessary and will witness the inspections/tests.

b) Testing Modules and Systems (Functional Tests)

This stage of Commissioning consists of the testing and operation of the Works, grouped together into modules and/or systems, as agreed between the Commissioning Manager and the Contractor.

At the end of the Cold Commissioning stage, the Contractor shall have corrected all the deficiencies that the Commissioning Team deems necessary to allow Hot Commissioning to continue in a safe and controlled manner. The project Engineering Lead, Commissioning Manager and the Project Manager may agree that some minor deficiencies could be corrected during the Hot Commissioning stage. Where specifically agreed to by TPT Project Team and BTS, the Contractor may remedy defects during the maintenance/warranty period.

To note the successful Completion of Cold Commissioning, the Transnet Port Terminals Senior Project Manager will prepare a Cold Commissioning Certificate (accompanied by a categorised Punch List). By signing the Cold Commissioning Certificate, the Contract Works are accepted by the Project Team for Care, Custody and Control and the Client becomes the "User" in terms of the OHS ACT but note (This is a Provisional TCC subject to successful Endurance Test; the 12 month warranty period would start after the endurance test).

7.3 Stage 3 – Hot Commissioning (System Integration and Load Tests)

This stage of Commissioning consists of placing the Works into operation by BTS with the assistance of TPT projects, Contractors and Equipment Suppliers, using the operating and maintenance personnel of BTS. Hot Commissioning includes performance testing of the Works in terms of the Contract.

a) Set-up and Tuning of system Parameters

During this phase, material, iron ore, will be introduced into the system to allow the Client with the assistance of TPT Projects to set system parameters and perform the necessary tuning.

b) Production build-up

Production build-up entails the verification of quality, process and reliability parameters during production cycles while production levels are increased to prepare for performance testing.

c) Acceptance/Performance Testing, Endurance Testing

After successful completion of commissioning, the equipment shall be subjected to acceptance testing, i.e. actual operation conditions.

The purpose of this test is to prove that the Plant operates under maximum expected operating conditions and that the safety and other mechanisms repeatedly operate as required and that the Plant is structurally and mechanically sound and ready for full operation.

Acceptance testing will comprise of a minimum of 40 hours endurance test (either continuous or consecutive sessions), of which the last 32 hours must be a completely trouble-free operation to the satisfaction of the Project Manager. If the operation is not trouble free, Endurance Testing will continue until the EQUIPMENT operates for 32 hours trouble free before the Endurance Testing can be deemed complete.

During this endurance test (the first 20 hours of the 40 hours), should there be any interruptions due to trips, faults etc., which can be reset in less than 1 hour, the test will continue. If, however it takes longer than 1 hour to get the Plant operational then the endurance testing hours will be reset zero.

During endurance testing, the Contractor must compile a register of faults, stoppages and test results indicating Date, Shift, Operator, Time, Duration and Description of the problem.

During acceptance testing the Plant will be operated by the Employer's operators, but the Contractor shall provide at his own cost the personnel and all equipment necessary for acceptance testing, including a sufficient number of suitably qualified people to assist the Employer's Plant operators for the duration of acceptance testing.

To note the successful completion of Hot Commissioning, the TPT Senior Project Manager will issue a Completion Certificate for Design, Supply and Installation. Contractors will undertake to complete all outstanding punch list work during the maintenance/warranty period and by an agreed date

8. PUNCH LISTING

a) Mechanical Completion Punch List

When in the opinion of the Contractor, the Works or part of the Works is sufficiently complete to warrant the commencement of Cold Commissioning of such Works, the Contractor will submit a request for a joint Mechanical Completion Punch list inspection, after having punched the works himself and cleared all Category 'A' and 'B' Punch list Items. Any additional Category 'A' Punch list Items identified by the Transnet Port Project team and BTS must be rectified before proceeding to the next stage. Once all Category A Punch List Items have been rectified a Mechanical Completion Certificate/Ready for Commissioning Certificate (RFC) will be issued to the Contractor.

For part of the structural contracts, a Construction Completion Certificate will be issued at this point. It is at this point that the Construction Manager handed over the completed project to the Commissioning Manager to proceed with the commissioning process.

The Construction Manager will be responsible to ensure that all construction related punch list items, that hinder the Commissioning Process, are cleared and completed before signing-over the Construction Completion Certificate to the Commissioning Manager.

Note: Mechanical Completion also means Electrical, Instrumentation and Control Completion where relevant.

b) Cold Commissioning Verification

Any functional defects/deficiencies identified during Cold Commissioning will be registered in the Deficiency Management Database for rectification and closeout.

When the Works has been Cold Commissioned, the Contractor will submit a request for a joint Cold Commissioning Punch list inspection to verify that all Category 'A' and 'B' punch items are completed and to ensure that any damaged plant or equipment are repaired prior to the issue of a Cold Commissioning Certificate.

For installation only contracts, a Completion Certificate must be issued at this point.

c) Hot Commissioning Verification

Any functional defects/deficiencies observed during Hot Commissioning will be recorded in the Deficiency Management Database for rectification and close out.

As soon as the *Contract Works* have successfully passed all applicable performance tests in accordance with the conditions of the relevant contract and upon completion of Hot Commissioning, TPT Project Manager and the Client verify that all functional defects/deficiencies recorded in the Deficiency Management Database have been investigated, resolved and closed out have been signed off.

For supply and install contracts a Completion Certificate will be prepared by the TPT Project Manager for acceptance by the Client.

d) Punch List Categories

Punch list items will be categorised into Category 'A', 'B' or 'C' punch items.

e) Punch List Register

All Punch lists must be registered with the Commissioning Manager who will maintain a Register of Punch list items in the Commissioning Database for follow-up and close out.

The Commissioning Manager will be responsible to ensure that all Commissioning Punch list Items are cleared and completed by the agreed date.

When items on the punch lists are cleared, the Commissioning Manager will ensure that the punch list register in the Commissioning Database is updated to reflect the status of punch list completion.

f) Functional Defects

Functional defects and deficiencies identified during the Commissioning and Maintenance phases will be recorded by the Commissioning Manager in the Deficiency Management Database and handed over to the responsible Contractor and/or TPT Projects for clearance.

8.1 Equipment Modifications

Any modifications required by the Client to any equipment, plant or control, should be identified before the commissioning process commences.

These Modifications to be identified during the construction/refurbishment phase of the project and managed according to the Change Control Procedure.

All proposed/required modifications shall be presented in writing, by the Client, in time not to delay the project commissioning phase, approved and logged in the change register.

If it is a Process change then a re-HAZOP must be carried out prior to the commencement of the work to ensure that the proposed process change is safe to implement.

Once the scope of the modification is finalised, the TPT Project Manager will examine and evaluate time and cost implications. Allocation of funds if required will be approved in accordance with TPT - Change Control Procedure prior to implementation of the change.

Requests for changes are not Punch List Items and must be logged and controlled outside the Punch List Process.

All requests for plant modification or comments from the Client's operating personnel must be channelled through the TPT Project Manager and TPT Construction Manager for review and approval, before the Commissioning Phase.

8.2 Safety Clearance Inspection

It is the responsibility of the Contractor to prepare the Works for Safety Clearance Inspections. The purpose of the Safety Clearance Inspection and Certificate is as follows:

- To ensure that the plant in question is safe to be energised from a mechanical, electrical and process perspective
- To ensure that the surrounding environment is conducive to safe operating practises i.e. no debris lying around, all trenches covered, barricades are installed, fire extinguishers available etc.

Any Health and Safety requirements identified during Punch listing must be rectified before the issue of a Safety Clearance Certificate.

When the prerequisites as defined above have been met, a Safety Clearance Certificate can be issued. Once the Safety Clearance Certificate has been signed the plant **MUST** be energised.

If for some reason the plant cannot be energised at that time, the process must be repeated just prior to the plant being energised.

After the issue of a Safety Clearance Certificate, plant can only be worked on under permit issued by an Appointed Person of the defined "User", in terms of the OHS Act to a Responsible Person (Refer to The Permit to Work Procedure). A copy of the Safety Clearance Certificate must, upon completion, be forwarded to the relevant Commissioning Manager. The responsible Commissioning Team will organise and co-ordinate these inspections and will only issue a Safety Clearance Certificate when the plant is safe to be energised. To ensure total safe working conditions, a series of checks and tests shall be made involving all disciplines, to establish the status of each piece of equipment. These checks and tests will include but are not limited to:

- Lubrication
- Alignment
- Rotation
- Power supply available and adequate
- Electrical equipment, safety checks and interface controls already checked out
- All safety precautions in effect; and
- What other equipment will also run and whether it was checked and declared safe via a Safety Clearance Certificate.

When tests and/or checks are to be carried out to demonstrate Mechanical Completion that involves the application of energy, such as megger testing of cables, a safe working procedure must be developed by the Contractors and demonstrated to the Commissioning Manager.

Prior to such tests or checks, a safety walk down of the equipment to be tested will be carried out by the Commissioning Manager and Commissioning Teams to ensure that the area is made safe, barricaded or demarcated, locked out where required, relevant danger signs attached and that only persons directly involved in such testing are allowed inside the demarcated area while testing is in progress.

The Commissioning Manager must inform all parties working in the immediate vicinity of such tests and of the dangers associated with the testing.

To provide a record of inspection and checks, to ensure the safety of all involved and to facilitate a systematic check out, a system of tags shall be used together with the Permit to Work system. These tags shall be sequentially numbered to facilitate a tracking system related to responsibility for safety. The issue and control of tags will be the responsibility

The Contractor shall arrange for visits by the relevant authority, provide all personnel and equipment necessary to conduct the tests as required and hand over to the Commissioning

Manager the documents and certificates of the approved equipment. The relevant Commissioning Team shall be present during tests for verification and acceptance as identified on the relevant Commissioning Plan (Hold and Witness Points). The unit/module/system to be energised will be locked out and tagged in accordance with the agreed lock out and tagging procedure as described in the BTS "Safe Lock-out Procedure".

8.3 Statutory Certification and Approvals

The Contractor shall obtain from the applicable authorities, all necessary certification and approvals for equipment in his scope of supply. Approvals are typically required for:

- EC&I infrastructure supplied
- Cranes and other lifting equipment
- Hydraulic Systems and other pressure vessels
- All other equipment listed by legislation

The Statutory Certifications and approvals shall be included in the Contractor's Safety file. To be checked and accepted by the Construction Manager and will form part of the Mechanical Completion/Ready for Commissioning Certificate (RFC) to be handed over to the Commissioning Manager.

8.4 Verification of Commissioning Activities

a) Commissioning Quality Control Plan (QCP)

The Commissioning Manager assisted by the Site QA/QC Coordinator prior to any commissioning activities taking place must develop a Master Commissioning QCP.

The following Commissioning QCP's need to be developed by TPT together with the Contractors and approved by Client/BTS prior to any commissioning activities taking place.

- Cold Commissioning QCP
- Hot Commissioning QCP
- Test and Evaluation QCP for Acceptance/Performance Testing

b) Commissioning Inspections

TPT Projects shall ensure that, prior to Commissioning QCP approval, the Contractor has broken down their Commissioning QCP to include adequate inspections and checks for each piece of equipment.

TPT Projects shall ensure that the Contractor's Commissioning QCP's make reference to relevant forms and check lists that will be required.

The Commissioning Team that includes Contractor's representatives and shall be recorded on the relevant forms and check sheets shall conduct commissioning inspections.

When the Commissioning Team for that specific unit/module/system is satisfied that Commissioning has been done correctly the Commissioning QCP shall be signed off.

c) Testing and Trials

Commissioning will only be considered complete when the Commissioning Team is satisfied that all necessary tests have been correctly completed and that the recorded data confirms that the relevant equipment or system is ready for the next Commissioning stage.

8.5 Care, Custody and Control

After Hot Commissioning, the Hot Commissioned system will be transferred to the Care, Custody and Control of the Client. The transfer is formalised only when the Client signs the Hot Commissioning Certificate.

TPT Projects Senior Project Manager will prepare the Hot Commissioning Certificate for signature by the relevant parties.

Defects Correction/Defects Liability/Warranty Period

All Categories 'C' Punch list items as well as defects occurring during the Defects Correction/Defects Liability/Warranty Period must be closed out before the expiry of the Maintenance/Warranty Period.

To facilitate the administration of the guarantees, all defects and/or repair work during the Defects Correction/Defects Liability/Warranty Period must be logged in the Deficiency Management Database.

The reporting of such defects/deficiencies is the responsibility of the Operating and Maintenance Staff. It is the responsibility of the TPT Project Manager in conjunction with the relevant Contractor, to determine whether such defects and deficiencies are the responsibility of the Contractor and should expedite the rectification of such defects and deficiencies.

8.6 Spares

The Principal Contractor and BTS shall be jointly responsible for provide critical spares for the SR3, at the Bulk Terminal Saldanha, quantified and as agreed between the parties, as detailed in the engineering reports (Z.5200160-ER) and Procurement Report (Z.5200160-PR). The technical performance specifications shall be submitted to the Project Team for approval prior to delivery.

9. ORGANISATION

The Contractor will be responsible for the planning of the commissioning together with the TPT Project Team well ahead of the commissioning phase meaning this document shall be revised and a detailed plan submitted for updates and comprehensive commissioning plan to address any commissioning loopholes if noted.

10. COMMISSIONING SCHEDULE

The Principal Contractor to provide a detailed commissioning schedule during the commissioning planning phase to be approved by the Project Team. This schedule to be aligned to the overall project schedule and the Cold & Hot Commissioning specifications mentioned in this document.

11. SAFETY

In addition to complying with applicable statutory health and safety requirements, the Contractor shall comply with TPT safety regulations and guidelines.

The Project Team shall provide the Principal Contractor with copies of the TPT safety, health, environmental, quality and risk documents, and the relevant updates thereof from time to time.

Commissioning staff will be required to attend the Transnet safety inductions, site-/task specific training and medical checks. Such staff must ensure that they are aware of normal operational- and other construction activities during the commissioning period. Appropriate safety equipment must be used.

All equipment is to be fully and properly commissioned without the bypassing of any safety systems or safety equipment. The designed processes, electrical-, instrumentation and control procedures to be adhered to. Where such bypassing is unavoidably necessary for commissioning purposes, even if detailed in the commissioning procedure, it will not be done without the written approval of the appointed responsible Engineer from BTS, on

evaluating of the written recommendation from the Commissioning Manager. Commissioning will take place in a set sequence. This will be strictly adhered to so that staff will not be expected to work in an unsafe environment or unduly long hours.

A policy of "Zero Tolerance" will be strictly adhered to and it will be the responsibility of the Commissioning Manager to ensure this is the case.

12. HAND-OVER PROCEDURES

The following data-packs, properly documented and filed both in Hard and Soft copies, would be required before handover of the Plant:

- All Structural Material Test Certificates
- Corrosion Protection Dry Film Thickness tests
- Alignment verification results
- Inspection reports
- Red Lining of Manufacturing drawings if applicable
- Signed off all commissioning certificates together with completed punch lists
- Required statutory documents upon receipt of complete documentation a Hand Over certificate to be signed by TPT.

12.1 Red Lining" of Commissioning Drawings

During Commissioning, all authorized changes to drawings, (such as P&ID's, Loop Diagrams, Control Circuits, Cable Schedules, O&M Manuals, etc.), will be marked up in RED on the set of Commissioning Drawings and Manuals.

Authorization to affect changes to Documentation will be done in accordance with the Technical Query Work Instruction.

Upon final completion of the update to the drawings, the status will be classed as "As Built" and the drawings will be revised to the next revision and issued to the Client.

12.2 Training and Manning

All personnel involved in Commissioning must be appropriately trained. This will require the recruitment or transfer of personnel in sufficient time for training to take place (This project will not require major training as it is a refurbishment of the existing plant equipment, but if there is any form of training required, the operational readiness report will detail the training information).

The Transnet Port Terminals Commissioning Manager must ensure that all staff involved in commissioning activities is familiar with the plant to be commissioned. It is Transnet Port Terminals responsibility, supported by its Contractors to provide trained personnel during Cold Commissioning. However, Client Operating staff should make use of this period to familiarize themselves with the plant, well in advance for training by BTS where specialist training in terms of the Contract is required.

Manning schedules must be prepared in good time for control purposes.

12.3 Contractual Certification

To note; the successful completion of identified stages of the Contract Works, Contractual Certification, as detailed below is required.

12.4 Mechanical Completion Certificates

As soon as in the opinion of the Contractor, the Works has physically been completed in accordance with the drawings and specifications as detailed in the Scope and Specification of the Works and that the Works or portion thereof is ready for Cold Commissioning to commence he shall arrange for an internal punch list to take place and rectify all category 'A' and "B" Punch List Items. Once Contractor is satisfied that the plant is ready for Cold Commissioning to commence, he shall complete a request for Punch Listing and submit to the Project Team who will arrange for a formal Punch List to take place. Once it is verified that the remaining Category 'A' and 'B' Punch List items, were addressed, the Construction Manager will prepare a Mechanical Completion Certificate for Signature by the various Parties and Hand-over the completed *Works* for Commissioning to the Project Team, to commence with Cold Commissioning.

12.5 Cold Commissioning Certificates

Once Cold Commissioning is complete with no remaining Category 'A' and 'B' punch items, the relevant Contractor must request the issuance of a Cold Commissioning Certificate.

The Commissioning Manager will, when requested by the Construction Manager, certify that Category 'A' and 'B' punch items have been signed off and that Contractor has agreed in writing to rectify any remaining deficiencies during the Defects Correction/Defects Liability/Warranty Period within 30 days, except for new defects.

12.6 Completion Certificates

As soon as the *Works* have successfully passed any required Performance/Acceptance Test with only Category 'C' Punch List Items remaining with a commitment to complete the Category 'C' Punch List Items by an agreed date during the Defects Correction/Warranty Period and following the application by Contractor for a Completion Certificate, a Completion Certificate will be issued.

12.7 Final Certificates

On expiry of the Defects Correction/Defects Liability/Warranty Period and once all punch list items, defects reported during the maintenance/warranty period and commercial issues are successfully resolved, Transnet Capital Projects shall arrange with Client to issue a Final Certificate to Contractor.

All punch list items, functional defects and deficiencies must be cleared before the issue of a Final Certificate.

13. RECORDS

All records generated in accordance with the requirements of this procedure retained in accordance with the requirements of: Archiving and Retention of Documents and signed over to the Client.

14. ANNEXURES

Annexure 1 – Commissioning Responsibility Matrix

COMMISSIONING PHASE	Principal Contractor				TPT Project Team		
	CONSTRUCTION MANAGER	COMMISSIONING MANAGER	ENGINEER	CONTRACTOR OR SUPPLIER	TPT	ENGINEERING AND MAINTENANCE	OPERATIONS
CONSTRUCTION							
Safety	A		I/V	R			
Planning	A		I/V	R			
Supervision	A		I/V	R			
Installation	A		A	R			
Quality/OCP	A		A	R		v	
CHECKOUT ACCEPTANCE							
Safety	I	R/A	I/V	I			
Planning	I	RIA	I/V	I			
Supervision	I	R/A	I/V	I			
Contractor Equipment Inspections & Punch Listing	I	R/A	v	I			
Check Construction in accordance with design/specification	V/A	A	R/A	I	v	v	v
Punch Listing	V/A	R/A	I/A	I	v	I	V/A
Check out Acceptance Certificate	V/A	R/A	A			A	A
STAGE 1:PRE-COMMISSIONING							
Safety	I	R	I/V	I	I		I
Planning	I	R/A	I/V	I	I		I
Equipment Inspection & Testing	I	RIA	I/V	I	v	v	v
Check construction in accordance with design /specification	I	v	R/A		v	v	v
Check Lists	A	R/A	I/A	I	v	v	V/A
Taking Over Certificate (Install Contractors)	A	R/A	A			A	A



COMMISSIONING PHASE	Principal Contractor				TPT Project Team		
	CONSTRUCTION MANAGER	COMMISSIONING MANAGER	ENGINEER	CONTRACTOR OR SUPPLIER	TPT	ENGINEERING AND MAINTENANCE	OPERATIONS
STAGE 2: COLD COMMISSIONING							
Safety	I	R	I/V	I	I		I
Planning	I	R		note 2	Note 1		Note
Check construction in accordance with design/spec.	I	v	R/A		v	v	v
System Inspection & Testing	I	R/A	I/V	I	v	v	v
Overall Systems Integration	I	R/A	I/V	note 2	v	v	v
Check Lists	I	R/A	I/A	note 2	v	v	V/A
Issue Commissioning Handover Packs	I	R/A	V/A		A	A	A
T.C.C		R/A	A			A	A
STAGE 3: HOT COMMISSIONING							
Safety					I	R	R
Planning					I	R	R
Check performance to specification	s	s	s		R	I	I
1st (example) tap		s	s		R	I	I
T.C.C.C		R	v		I	A	A
PRODUCTION & OPTIMISATION							
Safety						R	R
Completion of CAT 'C' punch items	I	R	I/V	I	v	A	A



Issuing of Site de- establishment Memorandum		R	I/V		v	v	A
--	--	---	-----	--	---	---	---

R = Responsible (Actively conducting accountable activities and control over others involved)

I = Involved (Actively rendering accountable assistance, part of the team doing day to day activities)

V = Verify (Only doing spot checks I verification)

S = Support (There to give support where required)

A = Approve

Note 1 = Where applicable

Note 2 = Where applicable



Annexure 2 – Commissioning File Contents

CONTRACTOR:		CONTRACT NO:			
NO	ITEM	DOCUMENT	CONTR.	DOCUMENT SIGN-OFF	
				TPT PROJECT TEAM	BTS
A	GENERAL				
01	Module Description				
02	Baseline Schedule Updated				
03	Commissioning Team				
B	MECHANICAL COMPLETION				
04	Module Data Books/Construction Work Packages				
OS	Request for Mechanical Completion Punch Lists				
06	Contractor/ TPT/CLIENT categorized				
07	Loop Checks and other required Electrical Check Certificates.				
c	COLD COMMISSIONING				
08	Manuals & Instructions				
09	List of Commissioning/Maintenance Spares and Tools & Report of Availability				
10	Safe Working Procedures				
11	Lubrication Schedule				
12	Request for Safety Clearance Inspection				
13	Cold Commissioning QCP and Check lists, Functional Specification, Data Sheets and P&ID's, Tagged Equipment List Single Line Diagrams				
14	Safety Clearance Certificate				
15	Request for Cold Commissioning Certificate				
16	Cold Commissioning Defects/Deficiency List				
17	Cold Commissioning Certificate				
D	HOT COMMISSIONING				
18	Hot Commissioning QCP & Checklists				
19	Hot Commissioning Defects/Deficiency List				
E	PERFORMANCE TESTING				
20	Performance Trial Notification				
21	Notification to Specialized Equipment				
22	Notice of Acceptance/Rejection				
23	Performance Test Requirements &				
24	Request for Completion Certificate				
25	Completion Certificate				
F	CLOSE-OUT				
26	Training Requirements and Reports				
27	Test Requirements & Certificates				



28	As-built Drawings				
29	Subcontractor's Document Register				
30	Final Certificate				
G	OTHER				
31	Index of Unit Packages & Locations				
32	Register of Unit Packages for Sign-out				

Annexure 3 - Mechanical and Electrical Completion Certificate/Ready for Commissioning Certificate (RFC). Completion of Construction

M & E Completion Certificate No.			
Date:		Originator:	
Project Name:		TPT Project Manager:	
Contract No:		Contractor/Supplier:	
Contract Description:			
System/ Equipment:			
Defects List items outstanding?	Yes <input type="checkbox"/>	No <input type="checkbox"/>	If yes, attach Defects List to this certificate
NOTE: 1.Category "A" and "B" Defects MUST be rectified prior to approval of this certificate 2.Defects List Item Nos.			
<p>It is hereby certified that the Installation of Equipment defined above has been successfully Inspected. Tested, Rectified as noted above, and is released for the "Cold Commissioning" stage of the work and that the attached Defects shall be rectified by the stipulated due dates. This release in no manner relieves the Contractor and/or his sub-contractors and/or Suppliers of his Contractual obligations in terms of the Contract, and/or warranty, and/or performance guarantee. It is the Contractor's obligation to ensure that the Installation of Equipment is safe in terms of the OHS Act of South Africa to progress into the "Cold Commissioning" stage of the work. The Designer hereby declares that the Installation of the Equipment defined above is safe to use in terms of the OHS Act of South Africa and is ready to be energized and used for "Cold Commissioning" purposes.</p>			
DESIGNATION	NAME	DATE	SIGNATURE
Principal Contractor			
ECM Project Manager			
ECM Quality Manager			
TPT Project Manager			



Annexure 4 - Completion of Cold Commissioning Certificate

CC Certificate No.			
Date:		Originator:	
Project Name:		TPT Project Manager:	
Contract No:		Contractor/Supplier.	
Contract Description:			
System/Equipment:			
Comments:			
Defects List items outstanding?	Yes <input type="checkbox"/>	No <input type="checkbox"/>	If yes, attach Defects List to this certificate
NOTE: Category "B" Defects MUST be rectified prior to approval of this certificate			
2. Defects List Item Nos.:			
It is hereby certified that the System and Equipment defined above has been successfully "Cold Commissioned", Rectified as noted above and is released for the "Hot Commissioning" stage of the work and that the attached Defects shall be rectified by the stipulated due dates.			
This release in no manner relieves the Contractor and/or his sub-contractors and/or Suppliers of his Contractual obligations in terms of the Contract, and/or warranty, and/or performance guarantee. The Employer hereby accepts in good faith the above referenced System and Equipment for "Hot Commissioning".			
The Designer hereby declares that the Installation of the Equipment defined above is safe to use in terms of the OHS Act of South Africa and is ready to be energized and used for "Hot Commissioning" purposes.			
DESIGNATION	NAME	DATE	SIGNATURE
Principal Contractor			
ECM Project Manager			
ECM Quality Manager			
TPT Project Manager			



Annexure 5 - Completion/Take-over Certificate

COMPLETION OF HOT COMMISSIONING AND SUCCESSFUL 40 HOUR ENDURANCE TEST

HC Certificate No.			
Date:		Originator:	
Project Name:		TPT Project Manager:	
Contract No:		Contractor/Supplier.	
Contract Description:			
System/Equipment:			
Comments:			
Defects List items outstanding?	Yes <input type="checkbox"/>	No <input type="checkbox"/>	If yes, attach Defects List to this certificate
<p>NOTE: 1. Category "B" Defects MUST be rectified prior to approval of this certificate 2. Defects List Item Nos.: See list attached if applicable.</p> <p>It is hereby certified that the System and Equipment defined above has been successfully "Hot Commissioned", Rectified as noted above and is hereby taken over by the Client and that the attached Defects shall be rectified by the stipulated due dates.</p> <p>This release in no manner relieves the Contractor and/or his sub-contractors and/or Suppliers of his Contractual obligations in terms of the Contract, and/or warranty, and/or performance guarantee. The Employer hereby accepts in good faith the above referenced System and Equipment.</p> <p>The Designer hereby declares that the Installation of the Equipment defined above is safe to use in terms of the OHS Act of South Africa</p> <p>The Contract Defects Liability starts as per the date stated below.</p>			
DESIGNATION	NAME	DATE	SIGNATURE
Principal Contractor			
ECM Project Manager			
ECM Quality Manager			
BTS Eng. Manager			
TPT Operations Manager			
TPT Project Manager			

Annexure 6 – Commissioning Team

Typical Commissioning Team Resource Diagram

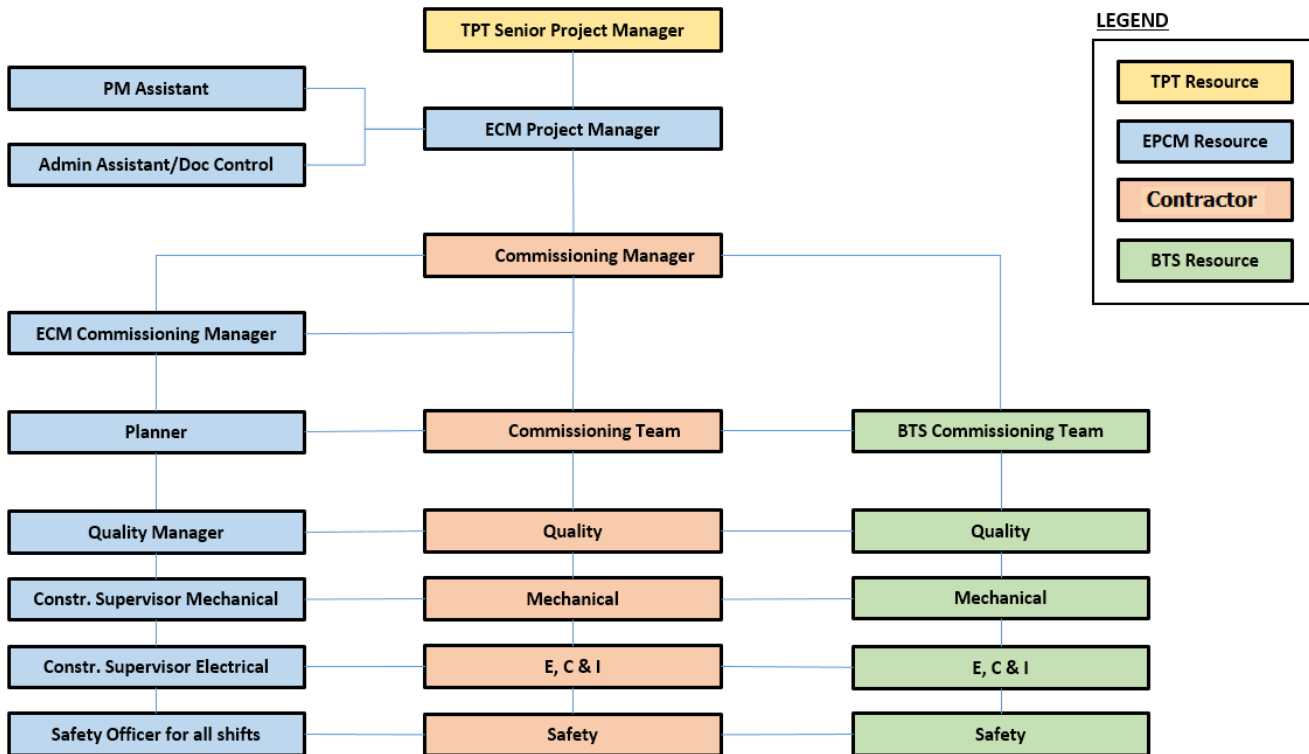



QUALITY MANAGEMENT PLAN

QUALITY MANAGEMENT PLAN

For: Transnet Port Terminals (TPT), Saldanha

Project Name: FEL3 - Saldanha Bulk Terminal Equipment Refit: Stacker Reclaimers, Ship Loaders and Tippler 2. (Phase-4: Stacker Reclaimer 3)

Project Number: Z.5200160

Author: Graham Handley

Owner: Louis du Toit (Terminal Manager)

Client: Transnet Ports Terminals (TPT)

Project Sponsor: Andiswa Dlanga (Managing Executive)

Project Manager: Graham Handley

Revision Number: 00

Approved by: Rejean Viljoen

Document No: Z.5200160-QMP

DOCUMENTATION DISTRIBUTION, REVISION AND APPROVAL HISTORY

REVISION NUMBER	DATE	DISTRIBUTION	PREPARED BY	REVIEWED BY	APPROVED BY
00	11/01/2021	1	G Handley	R. Drotskie	R. Viljoen

SIGNATORIES:

Prepared by:

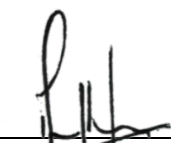

Graham Handley
Senior Project Manager

11/01/2021

Date

Reviewed by:

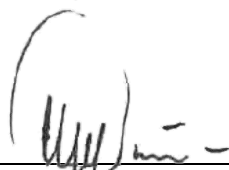

Riaan Drotskie
BTS Quality Manager

20/01/2021

Date

Approved by:



Riean Viljoen
SHERQ Manager

20/01/2021

Date

Table of Contents

1.	EXECUTIVE SUMMARY	6
2.	ABBREVIATIONS AND DEFINITIONS	6
3.	PROJECT SCOPE	9
4.	PURPOSE OF THE QUALITY MANAGEMENT PLAN	9
5.	PROJECT QUALITY REQUIREMENTS	10
5.1	Execution Strategy	10
5.2	Quality Objectives	10
6.	QUALITY ASSUMPTIONS	11
7.	QUALITY CONSTRAINTS	12
8.	PROJECT QUALITY RISKS	12
9.	QUALITY ORGANISATION	12
10.	QUALITY RESPONSIBILITY MATRIX	13
10.1	Roles and Responsibilities	13
11.	REFERENCES AND STANDARDS	17
12.	INTERFACE MANAGEMENT AND INTEGRATION	17
12.1	Lines of Communications	17
12.2	Project Change Management	17
13.	QUALITY ASSURANCE STRATEGIES	18
13.1	Project Quality Management Planning	18
13.2	Project Quality Assurance	18
13.3	Procedures	19
13.4	Contractor and Supplier Quality Documentation Requirements	21
14.	ENGINEERING AND DESIGN QUALITY MANAGEMENT	22
14.1	Preliminary Design	22
14.2	Engineering Document Review	22
14.3	Tender Document Review	23
14.4	Drawing and Document Review Participants	23
14.5	Review of Technical Specifications	23
14.6	Design Reviews	24
14.7	Document Change Control	24
15.	PROCUREMENT QUALITY MANAGEMENT	24
15.1	Overview	24
15.2	Quality Assurance Activities	25
15.3	Quality Assurance Levels	26

16.	CONSTRUCTION AND COMMISSIONING	27
17.	QUALITY AUDIT SCHEDULE	27
18.	QUALITY CONTROL STRATEGIES	28
19.	QUALITY CONTROL TOOLS AND TECHNIQUES	29
19.1	Quality Control in Design and Engineering	29
19.2	Quality Control Plans (QCPs)	29
19.3	Supplier Quality Control	30
19.4	Construction Quality Control	31
20.	PUNCH LISTING	31
21.	INSPECTION RECORDS, REPORTS, EQUIPMENT AND CONSTRUCTION DATA BOOKS	31
22.	FINAL HANDOVER, TAKEOVER AND ACCEPTANCE	32
22.1	Contractor Initiated Handover	32
22.2	TPT Project Team Initiated Takeover	33
23.	NON CONFORMANCE MANAGEMENT	33
24.	CONCESSIONS	34
25.	DEFECT LIABILITY MANAGEMENT	34
26.	SUPPLIER QUALITY MANAGEMENT	34
26.1	Long Lead Items	34
26.2	Supplier Audits	35
26.3	Contractor Documentation Register (CDR)	35
26.4	General Quality Control	35
26.5	Quality Control Plans and Data Books of Contractors / Suppliers	35
26.6	Quality Review of Contractor's / Supplier's Programmes	35
26.7	Inspection of Fabrication or Supply	36
26.8	Inspection on Receipt of Goods	36
27.	OFF SHORE PROCUREMENT	36
28.	EXTERNAL QUALITY ASSURANCE OR CONTROL	36
28.1	Inspection and Testing Laboratories Services	36
28.2	Third Part Inspection Agencies	37
29.	CONTINUAL IMPROVEMENT	37
30.	PROJECT QUALITY MEETINGS AND REPORTING	37
31.	PROJECT HANDOVER AND CLOSE-OUT	38
31.1	Handover, Operations and Maintenance	38
31.2	Administrative Closeout	38
31.3	Records Management	38
31.4	Contractual Close-Out	39
32.	APPENDIX:	39
32.1	A - Typical TPT - Quality Organisation	39
32.2	B - Typical Contractor - Quality Organisation	39



32.3	C - EEAM-Q-009 - QUALITY MANAGEMENT SPECIFICATION FOR SUPPLIER/CONSTRUCTION	39
32.4	D - EEAM-Q-013 - COMMISSIONING AND HANDOVER SPECIFICATION FOR SUPPLIER/CONSTRUCTION	40
32.5	E - Quality Control Inspection Process	40
32.6	F - Quality Control Plan (Example)	40

1. EXECUTIVE SUMMARY

This Quality Management Plan (QMP) has been compiled to detail the aspects of the project quality management system to be applied within the FEL4 phase of the equipment refit (Phase-4); Stacker Reclaimer 3, at the Bulk Terminal Saldanha. In addition it describes the methods to be utilised to ensure quality assurance and control of the identified activities as stated in the project execution plan (PEP), to ensure that the products and services meet Transnet Port Terminal's (TPT) requirements.

This QMP defines the overall quality management strategy that will support the project execution strategy as defined by the TPT Project Team. The following key aspects of the Quality Management Plan (QMP) pertaining to this project should be noted:

- TPT Project Manager will be responsible for managing all aspects of quality related to the execution of the works
- TPT Project Manager will provide the overall quality methodology in line with the required TPT standards
- TPT Project Manager will provide quality management resources to manage, and control and oversee the quality of all TPT appointed sub-consultants, suppliers and contractors
- TPT Project Manager will ensure that the correct documentation, the required QM System and Procedures, for the execution of the project, will be used and managed by those appointed. In addition, review and confirm the acceptability of suppliers and contractor's Technical Method Statements (TMS), quality control plans (QCPs) and related documents for execution of the work.

TPT Project QM will report on the quality performance of all project appointed consultants, suppliers and contractors.

2. ABBREVIATIONS AND DEFINITIONS

Term	Acronym	Definition
Authorised inspection agency	AIA	Authorised inspection agency accredited by the relevant authority to conduct independent inspections of specific works
Corrective action	CA	Action taken to eliminate the causes of an existing nonconformity, defect or undesirable situation to prevent recurrence
Contractor Documentation Schedule	CDS	A schedule of documents to be submitted by the Contractor at the indicated timelines.
Contractor Documentation Register	CDR	A list of documentation that the Contractor is to submit in accordance with the Contract. The Contractor is to use the Contractor Documentation Schedule (CDS) as the basis for developing the Contractor Documentation Register (CDR).
Critical goods and services	–	Goods and services that could have a significant adverse effect on safety, sustainability or productivity should they fail to operate as required

Concession	–	Agreement between the contractor and TPT or the engineer to use a part of the works that is not in accordance with the original acceptance criteria of the works information
Term	Acronym	Definition
Data pack	DP	A compilation of manufacturing data, certification, inspection and testing records prepared by the supplier or contractor to verify compliance with the contractual requirements
Design change notice	DCN	A document used by the supplier or contractor to formally clarify and obtain approval for design changes prior to or during manufacturing before implementation of the change
Engineering Construction Management	ECM	A company contracted to provide engineering and construction management services
Front End Loading	FEL	A project management methodology that ensures organized and progressively detailed project definition and execution development
Field engineering query	FEQ	A document used by the contractor to formally clarify and obtain approval for construction related design queries prior to implementation
Failure Mode Effect's Analysis	FMEA	A failure modes and effects analysis is an inductive failure analysis used in product development, systems engineering, reliability engineering and operations management for analysis of failure modes within a system for classification by the severity and likelihood of the failures
Lost time injury	LTI	A lost time injury (LTI) is an injury sustained by an employee that will ultimately lead to the loss of productive work time in the form of worker delays or absenteeism. An injury is considered a lost time injury only when the worker is unable to perform the regular duties of the job, takes time off for recovery, or is assigned modified work duties for the recovery period.
Transnet National Ports Authority	TNPA	Refers to TNPA, the Owner on behalf of whom the project is being undertaken
Hazard and operability study	HAZOP	A detailed hazard and operability problem identification process, carried out by a team. HAZOP deals with the identification of potential deviations from the design intent, examination of their possible causes and assessment of their consequences
Non-conformance report	NCR	A document used for recording, system, process or product related non-fulfilment of a requirement related to the intended or specified use
Major goods and services	–	Goods and services which could have a material impact on cost and/or schedule owing to potential rework issues, should they fail to comply with requirements on time
TPT Project Team	–	The Project Management Team that is responsible for overseeing the activities of the suppliers and contractors on the project

Procurement plan	-	A plan that describes in detail the contracting strategies to be employed to deliver the project to completion
Owners Requirement Specification	ORS	A document for the operation division to provide the project team with information relevant the execution of the project that only the operation division, due to an intimate knowledge of the facility or plant, may know.
Project quality plan	PQP	The internal document that defines the quality activities as planned evaluation of the adherence to the project's standards, processes and procedures as well as specific quality assurance measures related to each activity
Project execution plan	PEP	A document setting out the specific strategies, plans, systems and tools that will be used in the execution of the project in order to meet the project objectives for schedule, cost and quality
Quality	-	The degree to which a set of inherent characteristics fulfils requirements
Term	Acronym	Definition
Quality Assurance	QA	All those planned and systematic actions necessary to provide adequate confidence that a product or service will satisfy given requirements for quality
Quality Control	QC	The operational techniques and activities that are used to fulfil requirements of quality
Quality Control Plan	QCP	A document outlining specific manufacturing/construction inspection and testing requirements, including responsibilities, test acceptance criteria, nomination of witness and hold points
Quality management plan	QMP	A document setting out the specific quality practices, resources and sequence of activities relevant to a particular product, service, contract or project
Quality Management System	QMS	The organisational structure, responsibilities, procedures, processes and resources for implementing quality Management
Technical Method Statements	TMS	Detail method statement supplied by OEM/Principal Contractor for execution of individual scope items.
Responsible, Accountable, Consulted and Informed	RACI	A RACI chart is a matrix of all the activities or decision making authorities undertaken in an organisation set against all the people or roles. At each intersection of activity and role it is possible to assign somebody responsible, accountable, consulted or informed for that activity or decision.
Specification	Spec	The document that prescribes the requirements with which the product or service has to conform
Suppliers or contractors	-	TPT contracted suppliers, contractors, sub-consultants or any person real or juristic that supplies, fabricates, manufactures, installs, constructs or otherwise contributes material, plant or services to TPT in furtherance of the contract, the term contractor

		has the same meaning as applied to the term sub-supplier or sub-contractor
Works	–	All deliverables expected from the supplier or contractor as per the scope of works requirements specified in the contract between TPT and the supplier or contractor
Work package	–	A work package is a project deliverable constituted by the set of measurable work elements required to complete a unique activity or process in a specific time frame.

3. PROJECT SCOPE

The scope of a major refurbishment in relation to Stacker Reclaimer 3 can be categorized into four aspects, namely:

- Mechanical - includes components or systems such as the open gear systems, gearboxes, hydraulic systems, and rotating and moving parts (e.g. trunnions, car-clamps);
- Structural - includes wear liners, supporting structures (if required) and areas of possible structural damage (cracking deformation wear). Additionally, includes maintenance detection (e.g. non-destructive testing for fatigue fracturing) of areas where access to certain structures that is not normally possible while equipment is in service;
- Electrical, control and instrumentation - includes panels and drives that are approaching the end of their useful life or have become obsolete or, where newer technologies can be incorporated.

The high-level deliverables of the FEL4 execution (Phase 4 refit –SR3) includes:

1. Procure long lead items
2. Execute agreed volume mitigation plan
3. Procurement and contract award
4. Manage execution of the work & ensure adherence to Transnet’s standards & procedures
5. Test, commission and certify completion of the works
6. Draw up project close-out documentation

For further detail regarding the Scope of Work refer to the Owner Requirements Specification (Z.5200160-ORS).

4. PURPOSE OF THE QUALITY MANAGEMENT PLAN

The purpose of this QMP is to detail the project quality management system arrangement to be applied during execution FEL4 phase of the equipment refit Phase-4, Stacker Reclaimer 3, at the Bulk Terminal Saldanha as follows:

- Define the quality management system approach
- Outline the project quality objectives
- Define the project quality management processes and procedures
- Outline the QMP deliverables and serve as an appendix to the PEP

- Define quality roles and responsibilities (RACI)
- Ensure that the necessary monitoring and control activities are planned, for timely execution by relevant parties as a proactive approach.

5. PROJECT QUALITY REQUIREMENTS

5.1 Execution Strategy

TPT Project Team will adopt an engineering and construction management (ECM) approach, as the single managing contractor. In general, when and if required engineering supply contractors will be procured, appointed and managed by TPT Project Manager.

The suppliers or contractors' contracts will be directly with Transnet Port Terminals, under control of the TPT Project Manager through an ECM contractor, responsible for onsite construction management.

The project quality management execution strategy as described below is defined to support the stated project execution strategy as detailed in the PEP (Z.5200160-PEP).

5.2 Quality Objectives

The following quality objectives have been defined in the table below:

Quality Objectives	Measures	Responsibility
Project Management		
HSE	No LTIs (Lost Time Injury)	TPT Project Manager
Control Project budget	Budget versus actual expenditure	TPT Project Manager
Maintain Schedule	Planned versus actual progress	TPT Project Manager
Quality Management		
Promote quality management awareness to all affected stakeholders	Induction training Quality performance reporting Quality audits	TPT Quality Manager
Verify sub-consultants, suppliers and sub-contractors' compliance to agreed requirements	Inspection results or reports Supplier or contractor audits per schedule	TPT Quality Manager
Site receipt inspection verification and assurance for usage on the site	In process verification audits non-conformance reporting	TPT Quality Manager

Conduct quality audits	Compliance with project audit schedule Audit finding corrective action and close-outs	TPT Quality Manager
Construction		
To construct, works on time, on budget, within quality requirements which meets the projects needs and expectations	Approved budget versus deviation Approved schedule versus deviation Approved quality specifications and standards	TPT/ECM Construction Manager
Commissioning		
To plan for commissioning and handover successfully, on time, on budget within quality requirements which meets the projects needs and expectations	Approved budget versus deviation Approved schedule versus deviation Approved quality specifications and standards	TPT Project Manager, ECM Construction – and Commissioning Manager

NB: The above Quality Objectives shall be monitored and or updated by the relevant discipline lead and communicated in the project progress meetings.

6. QUALITY ASSUMPTIONS

The following assumptions regarding the project quality management system arrangements have been made:

- The TPT Project Manager will define the overall quality strategy prior to implementation.
- The TPT Project Manager will establish processes and procedures in accordance with Transnet Port Terminals PLP requirements for the project.
- The TPT Project Manager will be responsible for managing the performance of all suppliers and contractors in terms of quality.
- If there are any long lead items that need to be procured they will be managed as defined in the procurement plan and in accordance with the requirements as stated in Quality Requirements for Contractors and Suppliers (Ref: *EEAM-Q-009 Rev01*)
- Various sub-consultants, suppliers and contractors will be adequately staffed to fulfil their quality roles in the relevant disciplines.
- All contracted parties will be fully compliant with the quality requirements placed on them

- The costing for quality control (QC) activities for inspectors are based on the principle of single inspections for relevant hold or witness points and no additional inspections for any rejections.
- There are no known pressure vessels or other equipment requiring full accredited approved inspection authority (AIA) or any special investigation services, thus such services are excluded. Should costs be identified for such activities, a prior approval will be obtained from TPT via the change control process.
- Any rejected work, which needs to be redone will be for the Contractors account. Furthermore, no allowance has been made for special investigation personnel.

7. QUALITY CONSTRAINTS

Typical quality constraints shall be identified and managed during the execution of the project, but typically could be, but not limited to the following:

- Lack of understanding of the Transnet Port Terminals prescribed quality requirements by appointed sub-consultants, suppliers or contractors.
- Suppliers or contractor's capability to meet quality requirements as stipulated under Quality Requirements for Contractors and Suppliers (Ref: *EEAM-Q-009 Rev01*) and Engineering / Enquiry Specification.
- Supplier or contractor schedule performance.
- Shortage or lack of availability of competent personnel.
- Multiple areas being worked on at the same time could pose challenges to manage and control quality.
- Supplier quality surveillance in the event that off shore supplier are contracted.

8. PROJECT QUALITY RISKS

The TPT Quality Manager will participate in project risk workshops scheduled on the project to identify quality risks.

Quality risk will also be identified during:

- Design and HAZOP reviews (If applicable, no new designs applicable)
- Equipment FMEA analysis
- Supplier and contractor capability assessments.

Risk will in addition be identified by analysing trends from NCR's, concessions, inspections, assessment and complaints originating from Transnet Port Terminals. Risk will be analysed, reported, documented and incorporated into the project risk register.

9. QUALITY ORGANISATION

The TPT Project Team will provide adequate and sufficiently knowledgeable QA and QC resources for managing quality, taking into account the number of contractors or suppliers, location and proximity of manufacturing facilities/sites and fabrication or construction schedules.

The proposed quality organisation is as depicted in Appendix A of this document.

10. QUALITY RESPONSIBILITY MATRIX

Entity	Company	Quality Area of Responsibility
TPT Senior Project manager	TPT	Overall accountability to Transnet Port Terminals for quality delivery
		Responsible for ensuring the implementation of the project quality management system by all consultants, suppliers or contractors
TPT Quality manager	TPT & ECM	Responsible for ensuring that TPT's QMS requirements are defined and implemented on the project
		Ensure that quality requirements set out by TPT are incorporated within TPT's Quality Management Plan and are adhered to by TPT Project Management team.
TPT Engineering Manager	TPT	Responsible for quality requirements of TPT are implemented on the project
		Responsible for ensuring the ECM is meeting quality requirements
Construction Managers	PC & ECM	Responsible for site and construction quality management
TPT Procurement Manager	TPT	Responsible for supplier quality management on the project
TPT Site quality QA or QC coordinator/s and controllers	TPT/PC & ECM	Implementation of the site QMS requirements

The costs of the above-mentioned personnel have been allowed for within the project budget. Refer to the Basis of Estimate Z.5200160 for detail.

10.1 Roles and Responsibilities

The TPT Quality Team, as depicted in the Organogram (annexure A), will be appointed for the full duration of the project from set-up to handover and will be responsible, inter alia, for the activities listed below. Members within the TPT Project Team, will report directly to the TPT Senior Project Manager, who assumes overall responsibility for the project.

Review Documents:

- 1) Review Quality Management Plan.
- 2) Review and ensure that the Quality Control Procedures (QCP) drawn up by the Contractor/Supplier conforms with and will achieve the customer's specifications and requirements.
- 3) Review the Scope of Work, the Contract Specifications and appropriate National / International Standards, the drawings and the procedures.
- 4) Review contracts.
- 5) Review hot and cold commissioning procedures.
- 6) Review Method Statements (MST).
- 7) Review welding procedures, codes, and standards.
- 8) Review of approved WPS and PQR. Witness of welder qualification test (WQT) and procedure qualification test.
- 9) Review NDT procedures for suitability.
- 10) Review welders, NDT personnel qualifications and ensure that they are valid.
- 11) Review and approve heat treatment procedures and dummy charts.
- 12) Review pressure test procedures and other fabrication / repair procedures.
- 13) Review, verify material and consumable certificates.
- 14) Review; verify that the following procedures have been approved welding, repair, NDT, PWHT, Hardness test, Positive material identification, painting and coating.
- 15) Review; verify the calibration certificates of equipment and instruments such as welding machines, elcometers, shot blast profile gauges and temperature gauges e.c.t.
- 16) Review; verify weld maps, weld consumable maps.

Inspections During Construction:

- 1) Verify permit to work.
- 2) Ensure that incoming products conforms to the specifications stipulated. Contractors quality control checklist for products fabricated off-site to be reviewed.
- 3) Ensure that welding procedures and maps are being implemented in line with specifications and that checking and testing of welds conform to requirements.
- 4) Witness of material inspection, welding defect etc. Monitoring Welding activities as per WPS.
- 5) Performing daily inspections, including stores monitoring, consumable control etc. maintaining a daily diary, completing checklists and producing weekly summary reports for Quality Control Manager and the Operations Manager.
- 6) Monitoring materials traceability to ensure the right material is being utilized, Test Certificate Numbers and Company codes are being transferred and correctly recorded
- 7) Ensure that preheat treatment on material is performed if required.
- 8) Monitor welder's performance and visually inspect welds for defects.
- 9) Ensure that post weld heat treatment is performed on equipment if required.

- 10) Ensure that gauging, measuring equipment and other equipment requiring calibration is within the specifications set by the various standards as applicable.

Review NDT on Welds:

- 1) NDT inspections as per approved NDT procedures and/or applied specifications.
- 2) Product control inspections, including NDT inspections to be performed at different stages of the production process.
- 3) Monitoring of Pre heat, Inter pass temperature and inter pass cleaning as per WPS.
- 4) Visual inspection of completed welds. Monitoring PWHT, Verification of weld repairs work. Coordinated and communicated with fabrication supervisor, welders and inspection personnel.
- 5) If there is any NDT required on welds request for it to be communicated.
- 6) Review all and approve, sign off all NDT reports.

Corrosion Protection Shot Blast:

- 1) Ensure that the shot blast is clean.
- 2) Ensure that the shot blast profiles are correct before painting commences.
- 3) Ensure that equipment must be painted within 8 hours after shot blast is completed.
- 4) Review Corrosion protection Procedures

Corrosion Protection: Painting

- 1) Use paint thickness meters to test that the contractor has applied the 1st primer to the correct thickness according to Transnet's specifications.
- 2) Use paint thickness meters to test that the contractor has applied the 2nd primer to the correct thickness according to Transnet's specifications.
- 3) Use a paint thickness meters to test that the contractor has applied the final coat of paint correctly without any defects and ensure that it is the correct thickness according to Transnet's specifications.
- 4) Perform cross hatch sectional tests on paint work to ensure that the paint has adhered to the material.
- 5) Ensure that the equipment is painted the correct color according Transnet's specifications.
- 6) Ensure that there is insulation between dissimilar materials such as stainless steel and carbon steel.
- 7) Ensure that there is no corrosion on the equipment.

Inspections:

- 1) Inspect that all components are installed correctly.
- 2) Verify name plates are installed on equipment if needed and that they are applicable.
- 3) Verify As-built drawings.
- 4) Verify the concessions request, site query e.c.t.
- 5) Compile inspection reports.

- 6) Witness that all test that need to be performed on the equipment are done.
- 7) Perform all inspection checks on check list.
- 8) Perform inspections on received components and spares to see that there is no damage on components.
- 9) Ensure that all electrical work/components are installed correctly.
- 10) Ensure that there are no loose bolts and nuts on equipment's.
- 11) Ensure that the equipment is safe to use.
- 12) Ensure that all Transnet's decals, reflective tape and work loading signs are installed on the equipment.
- 13) Ensure that all required tools and spares are handed over to the port.

Inspection Reports:

- 1) Inspect construction work, and witness tests as required and sign the relevant Test / Inspection / Records.
- 2) Promote quality improvement and to highlight deficiencies which may be outside the scope of work e.g.: preservation and protection of materials and equipment, unprotected items in an external environment.
- 3) To carry out welding inspections, witnessing and releases when required.
- 4) To carry out any other inspection duties as requested by, and agreed with the Quality Control Manager.
- 5) Verify painting and coating inspection reports.
- 6) Issue NCR, s if any procedures weren't followed during the fabrication of equipment.
 - 1) Ensure closure of all NCR's before the equipment is handed over.
 - 2) Perform final commissioning on the equipment and ensure generation of a punch list.
 - 3) Ensure category 1 and 2 punch items are closed before the equipment is handed over for its endurance test.
 - 4) Ensure that the equipment completes its 40 hour endurance test according to Transnet's specifications.
 - 5) Ensure that all category 3 punch items are completed before the final hand over is completed.

Improving Quality:

- 1) Conduct periodic and systematic inspections audits, based on audit observations such as non-conformance, any other quality related issues, take preventive actions and avoid such things occurring in the future.
- 2) Conduct quality related meetings with inspectors, other department members, and look for ideas to improve quality or any quality related concerns they have in their job, take necessary preventive actions.
- 3) Any complaints from clients or feedback from clients, take necessary preventive actions.
- 4) Technical information related to quality; circulate to all concern department members.

Hand Over Documents

- 1) Verify that all hand over documents are complete, correct and signed off.
- 2) Review and ensure that all data books are handed to the terminal including parts lists and operational manuals.
- 3) Ensure that the personnel using the equipment are properly trained.

11. REFERENCES AND STANDARDS

The following references and standards are applicable to the project:

Standard Number	Description
ISO 9001:2015	Quality Management Systems - Requirements
ISO 10005:2018	Quality Management – Guidelines for Quality Plans
ISO 17025:2017	Competence of Testing and Calibration Laboratories
ISO 9000:2015	Quality Management Systems -Fundamentals and Vocabulary
Z.5200160 - ORS	ORS – Owner Requirements Specification
Z.5200160 - PEP	Project Execution Plan
EEAM-Q-009 Rev01	Quality Requirements for Contractors and Suppliers
Various as listed under item 13.3 of this document.	Transnet Port Terminals - Quality Procedures

12. INTERFACE MANAGEMENT AND INTEGRATION

The PEP shall adequately address the integration levels of all affected functions with Transnet Port Terminals and other stakeholders including:

12.1 Lines of Communications

The lines of Communication between the TPT Project Team and external stakeholders (contractors, sub-consultants, public etc.) shall be defined in the Communication Management Plan.

12.2 Project Change Management

The PEP shall adequately address how all technical changes on the project are going to be managed, this includes but not limited to:

- Project changes notices (PCN)
- Project Managers Instruction (PMI)

- Design changes
- Field engineering queries (FEQ)
- Document changes
- Concession leading to a change as applicable
- Deviations.

13. QUALITY ASSURANCE STRATEGIES

13.1 Project Quality Management Planning

The TPT Project Team will provide the overall management framework within which the project shall be executed. This framework consist of guidelines and standards that provide sub-consultants, suppliers and contractors with the minimum requirements of **'what'** is required for the execution of the works.

The TPT Project Team will provide all its services by following the Transnet Port Terminals PLP project management approach, and shall where necessary implement and/or supplement the guidelines, standards and procedures with project specific management procedures as required.

The TPT Project Team will define the project quality management system by determining the:

- Project quality policy
- The applicable standards, guidelines and procedures
- The quality objectives and responsibilities
- Implement them by means such as quality planning, quality control, quality assurance and quality improvements for execution.

The TPT Project Team shall issue Quality Requirements for Contractors and Suppliers (Ref: *EEAM-Q-009 Rev01*) for suppliers and contractors to understand **'what'** is required for the execution of the work they have been contracted for.

This specification shall form part of the contract between Transnet and the suppliers or contractors.

The appointed sub-consultants, suppliers and contractors shall implement their own procedures on **'how'**, work shall be designed, engineered, manufactured and constructed during execution of their scope.

13.2 Project Quality Assurance

The quality assurance programme shall provide a systematic and cost effective means of ensuring that the TPT Project Team activities meet the required systems, standards, specifications, works information or scope of work, engineering drawings and complies with applicable government acts, regulations, codes and applicable permits as may be used.

13.3 Procedures

The TPT Project Team will ensure that processes or procedures and plans (indicative) for the following activities or processes as detailed in table below are implemented during execution of the project:

Project Management Plans	
Project execution plan	Risk management plan
Safety management plan	Environmental management plan
Communication management plan	Basis of estimate
Engineering Plans and Procedures	
Engineering management plan (N/A)	Engineering drawings procedure (N/A)
Procedures for preparation design criteria (N/A)	Procedure for checking engineering documents (N/A)
Preparation of equipment lists (N/A)	Engineering change control (design changes and field engineering queries) (N/A)
Preparation of an engineering requisition (N/A)	Drawings master mark ups
HAZOP procedure	Engineering design, planning and control (N/A)
Technical tender evaluation procedure	Design review guidelines and checklists (N/A)
Quality Management Procedures, Plans and Specifications	
Quality management requirements specification for suppliers and contractors	Supplier and contractor assessment
Project quality plan and site quality management plan	Quality management reporting
Preparation of project quality documentation	Quality control procedure
Internal auditing	Concession request
Quality management reviews	AIA services
Non-conformance management	iPas suite/iPas DM report manual
Procurement Management Plans, Procedures and Guidelines (To be aligned with the applicable Transnet Port Terminals Processes and Procedures)	
Procurement management plan (procurement strategy)	Contract award

Procurement package plan	Contract claims
Enquiry document preparation	Contract variations
Selection of tenders	Process progress payments
Manage tendering process	Contracts and project close-out
Receiving and opening tenders	Vendor surveillance procedure
Evaluate tenders	Progress monitoring and expediting
Construction Management Plans, Procedures and Guidelines	
Materials management plan	Field finance
Construction management plan	Site quality control
Construction facilities plan	Work package procedure
Site security and access control	Workface planning procedure
Site induction	Construction engineering
Construction planning	Contracts administration
Site organisation	Site materials management procedures
Site meetings	Material management warehousing
Site visit fact finding	Site job bulletins
Site administration	IT procedure
Industrial relations	Site quality manual
Construction administration procedure	Construction close-out
Field human resources	Construction punch listing
Site project controls	Construction access
Commissioning Management	
Commissioning plan	Pre-commissioning scheduling
Commissioning functional guide	Field reports
Commissioning organisation and standards	Facility incident report
Commissioning procedure manual	Temporary alterations log
Commissioning manual for inspection testing and trials	Field correspondence control
Constructability implementation	Conference meeting and trip reports

Construction, pre-commissioning, commissioning and operation interface	Daily log
Component system turnover - construction to pre-commissioning	Pre-commissioning progress reporting
Component system turnover - pre-commissioning to commissioning	DCS field change notice
Scoped drawings and turnover packages	Service representative call out and monitoring
Safety tagging	Equipment maintenance control
Work authorisation	Pre-commissioning technical program
Punch list procedure	Test equipment control

Suppliers or contractors shall plan and implement their own procedures required for the execution of their scope, subject to approval of TPT Project Team.

13.4 Contractor and Supplier Quality Documentation Requirements

All Transnet appointed suppliers or contractors shall list all documents required for the scope of work or package and shall as a minimum provide the following project specific documents, as applicable, if not already defined in the Contractor Documentation Schedule (CDS) submitted with the tender enquiry:

- Project quality policy
- Project quality objectives
- Project quality plan
- Project organisation chart
- Project RACI matrix
- Job descriptions and CVs of quality personnel to be deployed
- Design (EMP, design QCP and equipment criticality list)
- Installation inspection and testing plan
- Construction inspection and testing plan
- Commissioning and take-over
- Project QCPs – per work package (e.g. civil, architectural, services, electrical etc.)
- Project QC procedures per individual activity identifying specific inspection and test methods and acceptance criteria
- Project inspection and test plans or QCPs per individual activity that plan and assure quality and define inspection intervention levels

- Project verification records per individual activity as referenced on QCPs/ITPs (e.g. certificates of conformance, inspection reports, inspection checklists, etc.)
- Manufacturing, construction and commissioning data books.

14. ENGINEERING AND DESIGN QUALITY MANAGEMENT

14.1 Preliminary Design

As this is a refurbishment project and components will be replaced on a 'like for like' basis, there will be no design work involved. If for any reason design work is required the below-mentioned will apply.

Preliminary design focuses on developing the information required to obtain quotations on pre-purchased equipment packages.

TPT Project Team will provide the project design criteria. The design criteria present project specific standards to be used in the design process. The standards can be applicable to the project, national, industry and internal standards or statutory laws. In effect, the design criteria describe how the project's end product will be designed.

The design criteria and the basis of design are key inputs to the design process. Based on these documents, each discipline initially produces:

- Concept drawings
- Standards procedures and specifications
- Records and Reports (documenting the results of design studies and the evaluation of design alternatives).

Generally, the drawings, procedures, specifications and reports are verified and approved for consistency and conformance with the design criteria, and other drawings, procedures, specifications or reports before being issued to the Client for comment or approval. In addition, equipment specifications are verified and approved for conformance with applicable general specifications.

14.2 Engineering Document Review

Each drawing and document that is reviewed will be reviewed for consistency and conformance with:

- Design acceptance criteria
- Overall project objectives
- Scope definition documents
- Other drawings by the same discipline in the same area
- Other drawings in other areas (especially interfaces)

- Project drawings design template
- Clarity of instruction and language used.

All drawings, documents, lists etc. will be reviewed prior to being issued for tender and fabrication or construction.

14.3 Tender Document Review

The package engineer will manage the change process for:

- Initial issue for construction (if the drawing has been revised since the tender issue)
- All subsequent issues (if the drawing has been revised).

14.4 Drawing and Document Review Participants

Participants in the review of a set of contract drawings will be selected based on the drawings being reviewed in accordance with the RACI matrix. Potential participants include, but not limited to:

- TPT Senior Project manager
- TPT Construction manager
- TPT Engineering manager
- TPT Quality manager
- Project engineer (civil, structural, electrical as applicable)
- TPT project discipline engineers (civil, structural, electrical as applicable)
- Responsible engineer (civil, structural, electrical as applicable)
- Quantity surveyor
- Technical specialists (as required).

14.5 Review of Technical Specifications

Prior to being issued for tender, the project engineering manager is responsible to review and approve all technical specifications and other engineering documents for consistency and to ensure:

- The technical document complies with the overall project scope and objective
- Related drawings and other documents are included
- Client specific requirements are included
- Completeness and clarity of the document
- Alignment with design acceptance criteria.

14.6 Design Reviews

As this is a refurbishment project and components will be replaced on a 'like for like' basis, there will be no design work involved. If for any reason design work is required the below-mentioned will apply.

Formal design reviews with the OWNER participation will be conducted. The first review is typically carried out during basic engineering and determines that the main design concepts are correct.

The second review typically occurs after the detail design has been substantially completed and addresses all design issues including constructability and maintainability.

- Review 1 (approved for detailed design): concurrent multidiscipline signs off through a formal design review of reports or layouts to allow start of detailed design
- Review 2 (approved for construction): Formal design review used to confirm that output or deliverables could be issued for construction and signed from originator through to professional engineer or project manager with the appropriate issued for, stamp displayed.

Following internal review, designs shall as applicable be submitted to the OWNER for review and approval before construction commence.

Evidence of all design reviews must be maintained.

14.7 Document Change Control

All document changes shall be in accordance with the approved procedure.

15. PROCUREMENT QUALITY MANAGEMENT

15.1 Overview

The overall approach to quality management for the procurement of goods and services consists of:

- Input into the adjudication of suppliers.
- Ensuring that suppliers have plans for controlling work processes.
- Monitoring their compliance with the plans.

In summary, the suppliers will be responsible for the quality of their work while the TPT Project Team will be responsible for verifying and monitoring that the suppliers are fulfilling their obligations.

Quality management activities during the process of procuring goods and services consists of:

-
- Defining quantitative bid evaluation criteria for use on all purchase packages (bid analysis, evaluation and recommendation)
 - Ensuring that all of the technical and commercial requirements are adequately defined in the bid documents
 - Auditing or assessing potential suppliers or contractor of services
 - Selecting suppliers or contractors that best meet the evaluation criteria
 - Verifying that each suppliers or contractors is in conformance with his QMP as defined in the purchase order
 - Verifying the performance of each supplier or contractor against the specification and QMP during the delivery of the goods or services as called for in the purchase order or contract.

The responsibility for managing supplier or contractor quality is shared between engineering, procurement and the quality manager.

Engineering is responsible for defining the specific quality requirements applicable to pre-purchased equipment packages and for determining the technical acceptability of bidders.

The quality manager is responsible for reviewing the commercial recommendation of bidders and inspection or surveillance of suppliers. As required, engineering will assist in these recommendations.

15.2 Quality Assurance Activities

A quality surveillance program will be developed by the TPT Quality manager, to monitor and evaluate supplier or contractor procedures, methods, products and records to ensure conformance to specified requirements.

This program will be administered by the TPT Quality manager, directing discipline specialists, field representatives and quality inspectors employed for verification and witness inspection activities.

The quality surveillance program will commence upon award purchase order and/or contract and will include but not limited to the following activities:

- Evaluating suppliers' or contractors' QA and QC programs
- Evaluate suppliers' or contractors' special processes for validation and effectiveness
- Monitor the preparation of inspection and test plans (ITPs) by suppliers and contractors.
- Monitor preparation of data books by suppliers and contractors.
- Monitor and review material certification, traceability and documentation by suppliers and contractors.
- Technical review and acceptance of design documents
- Supplier and contractor quality surveillance
- Review and acceptance of ITPs

- Review and acceptance of data packs
- Non-conformance applications, which are in effect changes to specification requirements
- Technical queries initiated for technical review and resolution by the company representative
- Direct material substitution requests by suppliers and contractors.
- Data book compilation
- Package change management (deviations and concessions).

15.3 Quality Assurance Levels

During the procurement cycle, the TPT Project Team will specify in the technical specifications, the material classification of all components and/or sub-assemblies as required by the specifications. A criticality analysis shall be used to determine the need for and extent of QCPs including third party intervention points.

The criticality analysis shall evaluate the combined effect of the likelihood of failure and the consequences (impact) in order to determine the level of quality assurance, quality control and inspection and testing required in order to optimise the use, effort and effectiveness of the quality management program and resources during design, manufacturing, construction and commissioning.

The appointed designer shall define the criteria on which the criticality assessments should be based with the relevant criticality rating definitions.

The criticality rating assigned, shall determine during design, manufacturing, construction and commissioning and as applicable the level of:

- Design and engineering management, QA, validation and review (e.g. design change approvals, independent third party design review, Owner design review or approvals)
- Level of meeting intervention (e.g. kick-off, post award clarification, pre-manufacturing kick-off, pre-inspection meeting, construction kick-off meeting)
- Level of document review and checking (e.g. for approval, for review and comment or information, self-check, discipline check, inter-discipline check or independent check)
- Level of QC to be applied (e.g. if an ITP or QCP is required or not, and phases for which required e.g. design, manufacturing or installation)
- Level of inspection to be conducted (e.g. no inspection in case of commercial quality or resident inspection)
- Level of inspection intervention (e.g. surveillance, witness and hold inspection)
- Level of material certification (e.g. type A, B or C certificates – ISO 10204)
- Level of traceability (e.g. labelling, hard stamping, stencilling)
- AIA involvement or not.

16. CONSTRUCTION AND COMMISSIONING

The contractors shall plan and document and implement procedures to control manufacturing, construction and commissioning processes and submit the latter for approval to the TPT Project Team.

Planning for construction and commissioning shall include but not limited to the following:

- Access permits
- Takeover or handover certificates
- Punch and back punch listing
- Availability of engineer approved QCP or ITPs, inspection and testing procedures and related quality verification records
- Availability of engineer approved site erection plans, procedures, method statements, commissioning procedures and plans (if applicable)
- Availability of trained and competent personnel
- Competent and qualified QC inspection personnel
- Calibrated inspection and measuring equipment with substantiating calibration records
- Materials and/or equipment certified as released
- Availability of AIA.

The Contractor shall introduce a process for verifying (in conjunction with the TPT Project Team) whether all the planning requirements for the works have been met prior to commencement of work.

17. QUALITY AUDIT SCHEDULE

Project Audits shall be conducted with the intent to ensure that:

- Quality management activities have been identified and scheduled in the work plan or schedule and completed as planned
- Action items resulting from quality management activities are being acted upon
- Quality management activities actually add value by improving quality.

Audits shall be conducted as follows:

- By the Contractor Quality Manager
An initial quality audit is conducted once quality management activities have started. The results of the initial audit will determine the frequency of subsequent audits, but in general audit shall be conducted as follows:
 - Project execution(with further follow up audits as required based on audit results)
 - Close-out review before project close-out
- By the TPT Quality manager
 - Contractor or supplier capability assessments (before contract award)
 - Supplier or contractor audits (formal) shall be conducted periodically by way of reviews and follow up on action identified for corrective action

- By Transnet - Gate Review Team
 - Audits by Transnet - Gate Review Team or appointed auditor shall be planned for during the planning and execution of the project up until the Project close out phase.

The TPT Quality manager is responsible for coordinating the audits and will involve technical specialists as required. An audit plan shall be submitted for approval by TPT Project Team.

18. QUALITY CONTROL STRATEGIES

Quality control planning shall be an integrated part of the project management process and covers the entire engineering, procurement and construction management cycle and include as applicable for each phase of the execution the establishment of the following:

- **A project quality control plan (PQCP)** ensures that all the project functional or discipline specific management and control plans and procedures required for successful execution of the project have been defined and agreed with the TPT Project Team and is used to track delivery of the latter
- **Internal design reviews** In addition to frequent, informal design reviews, there are typically two formal design reviews. The first review (Review 1 approved for detailed design) is typically carried out during basic engineering and determines that the main design concepts are correct. The second review (Review 2 approved for fabrication or construction) typically occurs after the detail design has been substantially completed and address all design issues including constructability and maintainability
- **Internal squad reviews** of all project deliverables are conducted to ensure that all relevant role players interrogate and verify the technical correctness and validity of all project deliverables to ensure compliance. Deliverables may be subject to multiple internal and client reviews cycles before they are approved for use.
- **Set up reviews** are conducted to ensure that all the prescribed requirements for a specific phase of a project are verified on initiation of the project in order to identify and remedy any deviations and omissions
- **Project reviews** are conducted to ensure that the overall project objectives (schedule, budget and quality) and KPIs are met. Project reviews and progress evaluations cover all the project processes and provide an opportunity to assess the achievement of the project objectives. The outputs from these reviews and evaluations provide significant information on the performance of the project as well as any mitigations that should be implemented and as inputs into future management or project reviews
- **Contractor and supplier surveillance programmes** are developed by the TPT Quality manager, to review and evaluate suppliers and contractors' procedures (including QCPs), methods, products and records (including data packs) to ensure conformance to specified requirements. This program is administered by the project quality manager, directing discipline specialists, field representatives and the quality control inspection agency for verification and witness inspection activities.
TPT might have their own surveillance programmes.
- **Inspection and test programmes (ITPs) or quality control plans (QCPs)** covering design, manufacturing and execution as applicable, supplied by suppliers and contractors are reviewed and technically evaluated based on the criticality of items or equipment to ensure that the latter are manufactured or installed and constructed in accordance with the design requirements.

Inspections using checklists for guidance and trend analysis are key elements of quality control. QC verification, witness inspection and quality surveillance activities is carried out in accordance with the defined quality surveillance programme to ensure compliance with the relevant project specifications, codes and contract requirements.

19. QUALITY CONTROL TOOLS AND TECHNIQUES

19.1 Quality Control in Design and Engineering

The TPT Project Team will verify that sub-consultants, suppliers or contractors have implemented design plans (or equivalent controls) for all items that have been classified as major or critical.

These plans define the design and engineering quality management strategy to control quality in engineering.

19.2 Quality Control Plans (QCPs)

Prior to the start of execution all the Contractors QCP's shall be reviewed, revised (if required) and approved. See Annexure F for QCP example. QCPs are the activity specific documents to plan the assurance, control and verification of quality during fabrication, installation and testing and shall be compiled by the supplier or contractor for each unique manufacturing, construction or installation and commissioning activity, whether temporary or permanent works, or as required by the TPT Project Team engineer and shall describe in the following order:

- Process, inspection and testing activities in chronological order
- Process control (method statements or procedures) and quality control procedures
- Applicable design or contract specification
- Inspection intervention requirement
- Quality verification records (by document number) used to provide objective evidence that the specified quality characteristic has been achieved
- Inspection or defect identification status
- Traceability to works and work commencement or completion date
- Contractor verification and engineer endorsement.

TPT will forward all the project Quality Control Plans to TPT Quality Manager for review.

For manufacturing and execution activities the suppliers or contractors may utilise their own, or their sub-suppliers, standard QCP, provided that they account for providing the requirements as stated above, and facilitate the documenting of intervention requirements of suppliers, sub-supplier, the contractor, sub-contractor, the TPT Project Team and the AIA.

All QCPs shall be submitted to TPT Engineering for approval and insertion of the engineering and/or AIA inspection requirements and approval of the proposed inspection or testing verification records prior to their implementation.

Submittal dates of QCPs to the TPT engineer will be documented in the Contractor Documentation Schedule (CDS).

Works associated with a QCP will not commence until the latter has been approved by all identified signatories.

A Register of QCPs will be developed by the supplier or contractor throughout the lifetime of the project with the following:

- QCP document and revision number
- QCP titles (project name and project number)
- The relevant project number
- QCP planned and actual submitted status and dates to engineering
- Approval status
- QCP revision status.

The register will be provided in electronic format to TPT Engineering on a period to be agreed on.

QCPs will be completed as the work progresses.

All QCP's will where applicable be supported by records or data logging sheets, inspection reports or field inspection checklist (FIC).

TPT Engineering reserves the right to review QCP's at any stage during execution of the works to ensure progressive completion of the latter.

Any changes to QCP's after the work has started shall be approved by TPT Engineering and the prior working copy or version shall be retained and attached to the latest approved version for record of any activity to the stage prior to change.

Alternately minor changes to QCPs shall be done by marking up or adding and approval by signature next to change by relevant contractor representative and TPT Engineering.

19.3 Supplier Quality Control

Suppliers of major and critical equipment shall implement QCP's for management of quality of the equipment.

Supplier QCP's shall be reviewed and approved by the TPT package engineer responsible for the package prior to start of any work.

The package engineer shall indicate the required minimum witness and hold inspection that will be conducted by the TPT Project Team and TPT.

19.4 Construction Quality Control

While the site quality control plan provides the overview of control on the execution of the works, the inspection of more specific items shall be controlled by the use of construction or installation checklists, which provide a more detailed guideline of points to be reviewed.

The Contractor shall provide for a series of such check lists for use by the site management personnel. If required, these lists may be adapted to specific site requirements, or new ones developed, however, these variations should be reviewed or approved by the TPT construction manager and the site quality controller.

Once an item has been checked, it may be necessary to release it for further action by other contractors or disciplines, e.g. concrete plinths used for supporting structural steel, which is in turn used for supporting equipment or pipelines.

In these cases the relevant inter-disciplinary area release note shall be raised. The checklists shall be used on an attributed basis, whereby the persons responsible for the checking or inspection shall sign and date the applicable list in order to confirm that the checks have been carried out and are satisfactory.

All original checklists shall be retained for insertion in the data pack, held by the contractor, but they will not be considered valid unless signed by all the relevant inspection parties. Copies of all signed checklists shall be retained in document control.

20. PUNCH LISTING

When a contractor has substantially completed the agreed area or the defined building or infrastructure, it is incumbent on him to inspect that area in accordance with the latest revisions of the drawings and specifications in his possession, prior to calling the site construction management staff for the formal punch list inspection.

If, after the contractor has inspected his own work and that of his sub-contractor, he then considers the work to be substantially complete and of a satisfactory standard, he shall request the TPT-construction manager for an inspection giving an agreed period of notice. If the contract is such that a separate contractor represents each discipline, e.g. civil, mechanical and electrical, then measures will have to be taken to co-ordinate the disciplines' inspections to cover the required areas. This is necessary as the ultimate site inspection, prior to TPT Project Team's inspection, may be on a multi-disciplinary basis. If the contractor(s) requesting inspection has items outstanding, these may be listed with the inspection request form. However, such outstanding items shall be of a minor nature expected to be completed by the requested inspection date.

21. INSPECTION RECORDS, REPORTS, EQUIPMENT AND CONSTRUCTION DATA BOOKS

Suppliers or contractors shall be required to provide documented proof that their work has been manufactured or erected in accordance with the latest drawing revisions, to the agreed contractual standards and specifications and that all inspection and contractually agreed testing has been carried out and approved by all relevant inspection parties.

The quality verification records that substantiates conformity of the works shall be identified and listed for all works in a data pack that shall be submitted to Transnet on delivery (for material and equipment) or completion of the works.

The initial layout and index for the data pack shall have been agreed at the same time as the QCP.

The supplier or contractor shall ensure that data packs are compiled and signed off progressively, in order to ensure the minimum delay in presentation of the document prior to final completion.

The supplier or contractor shall complete a detailed Contractor Documentation Register (CDR) that will specify all document deliverables for all functions or disciplines and for all phases of the project and to be handed over to Transnet on completion of the works.

The Contractor Documentation Register (CDR) shall form the basis of monitoring contractor performance on document delivery and reporting of progress.

The supplier or contractor shall provide record storage facilities for all documents and verification records that will ensure:

- Protection from damage due to fire, theft or deterioration
- Controlled access by authorised personnel
- Controlled storage conditions such as temperature, humidity and air conditioning.

Records shall be filed in accordance with a system that suites the different types of works and indexed in order to facilitate ease of retrieval of records.

Records shall be made available at the supplier or contractor record facility for review by TPT Project Team as and when required.

22. FINAL HANDOVER, TAKEOVER AND ACCEPTANCE

Final handover and acceptance shall take place on completion in compliance with the quality and contractual requirements and upon final acceptance of the data pack by TPT Engineering via duly signed and approved certificates.

22.1 Contractor Initiated Handover

The contractor shall develop, document and implement a process for effective handover of the work as set forth in the contract.

The contractor shall upon completion of the contractual works:

- Verify that work is complete and conformant
- Ensure that a complete data book demonstrating compliance with the contract is compiled
- Produce an index of all handover quality records
- Formally apply to TPT Engineering for a request for handover for the works.

TPT Engineering shall upon application perform a review of the:

- Data book completeness
- Completed as built records
- Change management documentation (if applicable)
- Defect management documentation (if applicable).

Based on the results of the review, TPT Engineering will either accept or reject the request for handover.

Where handover has been rejected the contractor shall undertake the necessary rework and reapply for handover as per the contract.

When accepted, TPT Engineering will issue a formal takeover certificate.

22.2 TPT Project Team Initiated Takeover

Where the TPT Project Team requires to take over the works or a portion of the works, the TPT Engineering will identify the work or portion thereof and inform the contractor accordingly.

When the agreed portion of the work is complete and conformant the contractor shall process as per section 18.1 above and TPT Engineering will issue the relevant certificate.

23. NON CONFORMANCE MANAGEMENT

All non-conformances that occur during the course of supply, fabrication or construction, will be processed by the supplier or contractor such that specification compliance is achieved. A copy of all supplier or contractor NCR, with proposed corrective action or disposition will be reviewed and approved by:

- TPT Quality manager
- TPT Engineering
- Company's applicable technical representative
- Consultants (engineer of record) as required
- Client when applicable.

Product or items not conforming to specified requirements shall be immediately identified, segregated, tagged or marked as such by the supplier or contractor using a formal documented system.

The parties will evaluate the potential for adverse impact on the project. The NCRs will be regularly reviewed at suppliers or contractor premises as part of the quality surveillance programs, to verify effective control and close-out.

Non-conformances that occur as a result of audit, will be recorded on a non-conformance report (NCR) by the audit TPT Project Team and will be managed from corrective action and preventative action, to close-out by the supplier or contractor. These non-conformance reports will be regularly reviewed at suppliers or contractors premises as part of the quality surveillance and audit programs, to verify effective control and close-out.

Supplier or contractor requested disposition of non-conformances which would result in a specification deviation will be notified in writing to the project quality manager, by returning the non-conformance report with requested deviation as an action item. The TPT Quality manager will coordinate an appropriate review which includes the technical, regulatory, health and safety and environment with the engineering manager or the construction manager and the area or discipline manager. The result will be presented for approval to the TPT Engineering manager or the TPT construction manager when required.

24. CONCESSIONS

Where a consultant, supplier or contractor requests a concession or waiver to deviate from the requirements of the purchase order, specification or standard as defined by the designer and conditions of contracting, the consultant, contractor or supplier shall raise the request with the TPT Engineering manager and project manager and the request shall be captured in the concession register.

The concession requests shall clearly identify all elements of the proposed concession together with any resulting technical, commercial and/or schedule impact or any benefits in cost saving to Transnet which does not have a negative effect on the project and to the design life.

No concession or waiver shall be implemented without formal written approval by TPT Engineering manager and TPT Project manager.

The completed original approved concession shall be updated in the concession register and included in the data pack.

25. DEFECT LIABILITY MANAGEMENT

Patent and Latent Defects

Adequate terms and conditions shall be included in the contracts of all suppliers or contractors for the management of defects discovered during construction and the defect notification period.

Contracts shall in addition provide for management of defects in line with applicable industry specific workmanship standards (e.g. model preamble of trades).

26. SUPPLIER QUALITY MANAGEMENT

26.1 Long Lead Items

Long lead items will be identified. The quality management systems to be implemented shall be based on the criticality of the relevant items. All the QMS system and/or processes as described in this plan will also be applicable to manage these items.

The relevant QCPs for the procurement of long lead items shall be approved by the TPT Project Team in advance to placing the order (during procurement process), in order to ensure that suitable quality control arrangements are applied.

26.2 Supplier Audits

Supplier audits shall be conducted as soon as an order or contract is awarded and priority shall be given to suppliers of critical and major equipment.

26.3 Contractor Documentation Register (CDR)

Documentation requirements for all enquiries and contracts shall be defined and documented via a Contractor Documentation Schedule (CDS) to be issued for each work package.

The package engineer shall ensure that Contractor Documentation Schedule (CDS) is completed for issue with each enquiry or contract or have been formally agreed with the supplier or contractor before order or contract placement.

26.4 General Quality Control

Planned surveillance and inspection for off shore equipment will be accomplished by the appointment of a third party inspection company for all long lead items classified as critical work packages. If available, in house inspection personnel will be used for major and minor long lead items.

Only competent inspectors, in their specific disciplines, will be used to monitor conformance to quality plans. The products and services criticality analysis shall be used to determine the need for and the extent of QCPs.

Critical products and services are those whose failure will result in significant consequence with respect to safety or production loss or delays or costs. Major products and services are those whose failure will result in significant consequence with respect to production loss or delays or costs.

26.5 Quality Control Plans and Data Books of Contractors / Suppliers

QCPs will be created with various levels of inspection requirements based on historical knowledge, cost or complexity of the supplied long lead products by the suppliers or contractors

These QCPs will consist of inspection sheets and plans for the inspector for every piece of long lead equipment to be supplied with the appropriate intervention positions.

26.6 Quality Review of Contractor's / Supplier's Programmes

The TPT Quality manager will review every contractor / supplier enquiry document for quality requirements and then perform a review of the selected contractor's / supplier's quality management system as required.

26.7 Inspection of Fabrication or Supply

Based on the inspection level, inspection will be performed on packages. Additional items will be reviewed at the contractor's / supplier's site to ensure that they fully comply with the quality requirements.

26.8 Inspection on Receipt of Goods

On delivery of long lead items to site, every item will be inspected to ensure that there has been no damage in transit.

An additional quality programme will be developed for site work and will be implemented by the site supervisors with periodic inspection from the TPT Project Team. This will include quality activities in terms of final inspection and punching, acceptance of data books and performance testing, handover and training, operating and maintenance (O&M) manuals, etc.

27. OFF SHORE PROCUREMENT

Special care and Quality Control measures to be put into place for Offshore Supplier's Quality surveillance for items procured off shore shall be planned for. The following minimum requirements shall be applied to all equipment procured offshore:

- Supplier capability assessments to be conducted before contract award to validate the tender submissions and identify any risks related to achievement of quality.
- TPT review of supplier QMPs, QCPs and quality checklists of critical identified components, throughout the fabrication process.
- Final quality check by TPT prior to taking delivery of the component.

28. EXTERNAL QUALITY ASSURANCE OR CONTROL

28.1 Inspection and Testing Laboratories Services

When required, the use of independent inspection and testing laboratory services shall be identified by the Contractor and formally communicated to TPT Project Team, who shall be responsible for contracting and payment for such services as provided. The TPT Project Team will verify the following:

- Testing laboratories are accredited by a recognized accreditation body to ISO 17025 as competent to conduct the required testing
- Reports are submitted to TPT Engineering indicating all observations and test results in compliance or non-compliance with the contract requirements
- Supplier or contractor provide samples of materials, design mix, equipment, tools, storage and assistance as requested
- Request for retesting due to non-compliance with the specified requirements.

Where contractors are required to use independent inspection and testing laboratory services they shall be subject to the same control as those specified above, however the cost related to the use of such services shall be borne by the contractor.

28.2 Third Part Inspection Agencies

When required, the use third part inspection agencies shall be identified by the Contractor and formally communicated to TPT Project Team, who will be responsible for contracting and payment for such services as provided.

The TPT Project Team will verify the following:

- Accreditation of such agency
- Competence of the assigned inspection personnel for the specific assignment
- Inspection Reports are submitted to TPT Engineering indicating all observations and test results in compliance or non-compliance with the contract requirements
- Invoices for payment of services.

Where contractors are required to use third party inspection services they shall be subject to the same control as those specified above, however the cost related to the use of such services shall be borne by the contractor.

29. CONTINUAL IMPROVEMENT

The TPT Quality manager will collate and analyse all NCRs on the project in an ongoing basis with the aim of identifying trends and identifying opportunities for improvement.

Information of NCRs raised on site related to quality of supply shall be feedback to the relevant suppliers and quality inspectors to prevent recurrence.

30. PROJECT QUALITY MEETINGS AND REPORTING

Reporting related to quality shall be done during all scheduled project progress and technical engineering meetings for site and off site work packages.

Formal quality reports shall be submitted on a monthly basis to Transnet Port Terminals as part of the overall project monthly progress report.

Ad hoc reports related to quality inspection shall be communicated to the project should concerns or deviations be noted.

The requirements for quality reporting shall include as applicable, but not limited to the following:

- Summary of quality performance including achievements and major quality problems
- Audits conducted on the works and summary of findings

- List of approved QCPs/ITPs for the works
- Latest document register (contractor document register)
- Latest Contractor Documentation Register (CDR)
- Updated non conformities (NCR) register
- Major quality problems
- Design changes – design change register
- Concessions - register
- Inspections performed (inspection register)
- Inspection schedule (forward view of at least two weeks)
- Photo records and logistics
- Data book status report
- Quality incident management.

Third Party Inspection Reporting (If applicable and required)

Third party inspection providers shall provide reports in accordance with the contractually agreed time frames, on matters being executed within the project schedule as planned and highlighting any deviations or potential risks to the project.

31. PROJECT HANDOVER AND CLOSE-OUT

The TPT Project Manager will implement a project close-out management plan to define the requirements for closure and in order to close-out the project in a controlled and consistent manner.

31.1 Handover, Operations and Maintenance

Upon completion of the project, the facility will be handed over to Transnet and the operation and maintenance of the facility will be the responsibility of the Terminal Operator. The handover certificates will be signed by TPT representative and copies shall be included in the final project documentation to be handed to Transnet Port Terminals.

31.2 Administrative Closeout

Administrative closure will consist of documenting project results to formalise acceptance of the product by Transnet. It includes collecting project records, ensuring that they reflect final specifications, analysing project success, effectiveness and lessons learned, and archiving such information for future use. Administrative closure is an ongoing process which will be dealt with as each phase of the project closes and not left until the end of the project. This will ensure that important and useful information is not lost.

31.3 Records Management

A complete set of indexed project records will be prepared for archiving by the appropriate parties. Any project specific or program wide historical databases pertinent to the project will be updated. Particular attention will be paid to archiving of financial records.

31.4 Contractual Close-Out

Contract documentation includes the contract itself along with all supporting schedules, requested and approved contract changes, any seller developed technical documentation, seller performance reports, financial documents such as invoices and payment records and the results of any contract related inspections or audits. The contractual terms and conditions will be complied with where they prescribe specific procedures for contract close-out. This will include formal written notice that the contract has been completed.

32. APPENDIX:

32.1 A - Typical TPT - Quality Organisation

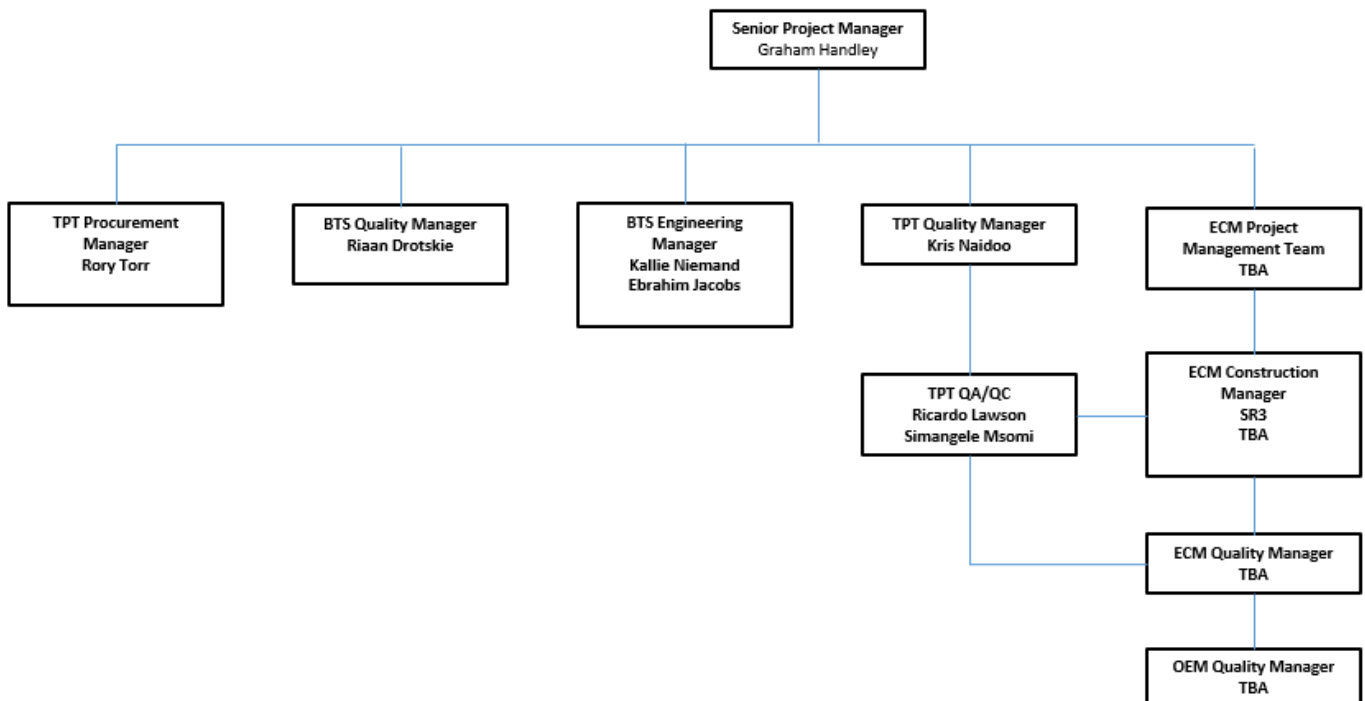

32.2 B - Typical Contractor - Quality Organisation

To be submitted by the contractor to TPT on appointment for review and acceptance.

32.3 C - EEAM-Q-009 - QUALITY MANAGEMENT SPECIFICATION FOR SUPPLIER/CONSTRUCTION

32.4 D - EEAM-Q-013 - COMMISSIONING AND HANDOVER SPECIFICATION FOR SUPPLIER/CONSTRUCTION

32.5 E - Quality Control Inspection Process

32.6 F - Quality Control Plan (Example)



CONSTRUCTION MANAGEMENT PLAN

CONSTRUCTION MANAGEMENT PLAN

For: Transnet Port Terminals (TPT), Saldanha

Project Name: FEL3 - Saldanha Bulk Terminal Equipment Refit: Stacker Reclaimers, Ship Loaders and Tippler 2. (Phase-4: Stacker Reclaimer 3)

Project Number: Z.5200160

Author: World Crane Services
Owner: Louis de Toit (Terminal Manager)
Client: Transnet Port Terminals (TPT)
Project Sponsor: Andiswa Dlanga (Managing Executive)
Project Manager: Graham Handley

Revision Number: 00
Approved by: G Handley

Document No: Z.5200160-CMP



DOCUMENTATION DISTRIBUTION, REVISION AND APPROVAL HISTORY

REVISION NUMBER	DATE	DISTRIBUTION	PREPARED BY	REVIEWED BY	APPROVED BY
00	05/01/2021	01	WCS	G. Abrahams M. Mazubane	G Handley

SIGNATORIES:

Prepared by:

World Crane Services
 Consultant

05-01-2021

Date

Reviewed by:

G. Abrahams
 Chief Operations Manager

02 February 2021

Date

Reviewed by:

M. Mazubane
 Snr. Manager – Capital Execution

02/02/2021

Date

Approved by:

G. Handley
 Snr. Project Manager

02/02/2021

Date

Table of Contents

1. Owners Objectives and Benefits.....	6
2. Introduction.....	7
2.1 Purpose	7
2.2 Scope	8
2.3 Document Status	8
3. Construction Management prior to Site Establishment.....	8
3.1 General Site Description	8
3.2 Contractor Site Establishment & Traffic Management	10
3.3 Site Office Facilities	12
3.4 Project Schedule.....	12
3.5 Scope of Works	13
4. Construction Strategy	16
4.1 General Construction Execution.....	16
4.2 Construction Methodology	16
4.2.1 Outage Plan.....	16
4.2.2 Construction Sequencing / Details.....	17
4.2.3 Construction precautions.....	18
4.3 Material Supply.....	18
4.3.1 Materials Supplied by the Contractor	18
4.3.2 Materials Supplied by Transnet.....	18
5. Construction Phase.....	18
5.1 Kick-off meeting with Principal Contactor	18
5.2 Construction Facilities.....	19
5.2.1 Site Camp, laydown areas and Offices.....	19
5.2.2 Access.....	19
5.2.3 Parking.....	20
5.2.4 Construction Water.....	20
5.2.5 Construction Electricity.....	20
5.2.6 Construction Waste Management.....	20
5.3 Management of Construction Issues	20

5.4	Constructability.....	21
5.4.1	Background	21
5.4.2	Client/BTS Operational Interfaces	21
5.4.3	Support to Contractors.....	22
5.4.4	Health and Safety Management	23
5.4.5	Environmental Management	23
5.4.6	Quality Management.....	23
5.4.7	Engineering and Method Statements	23
5.4.8	Security and Access Control	23
5.4.9	Industrial Relations.....	24
5.4.10	Communication Management	24
5.4.11	Risk Management.....	24
5.4.12	Interface	24
5.4.13	Procurement	24
5.4.14	Sub-Contracting	25
5.5	Construction Execution Plan.....	25
5.5.1	Prior to Site Establishment	25
5.5.2	Construction Site Establishment Phase	25
5.5.3	Integration with Functional Areas	25
5.5.4	Commissioning, Testing and Handover	26
5.5.5	Site Demobilisation and Close-out.....	26
6.	Roles and Responsibilities	26
6.1.1	Construction Management Organisation	26
6.1.2	CMC Project Manager	29
6.1.3	Construction Manager/Commissioning Manager	29
6.1.4	Site Supervisors	30
6.1.5	Site Quality Assurance Officer/Manager	30
6.1.6	Health and Safety Officer	31
6.1.7	COVID 19 Compliance Officer	33
6.1.8	Contractor/Service Provider Professional Health and Safety Agent	34



6.1.9	Environmental Officer	35
6.1.10	Document Control	36
6.1.11	Industrial Relations Practitioner	37
6.1.12	Principal Contractor and his Sub-Contractors.....	37
6.1.13	All Personnel.....	37
7.	Commissioning, Testing and Handover	38

1. Owners Objectives and Benefits

The Bulk Material Handling (BMH) Equipment Refurbishment project is required to ensure the optimal operational use and availability of the existing BMH equipment at the BTS. Execution of the four-phase project, is scheduled to coincide with the annual Iron Ore Industry shut.

The objective of the project is revenue protection.

This refurbishment project is not an equipment upgrade and no increase in throughput or extension of design life of equipment will therefore be realized.

This scope is related to **Phase 4**. This includes the refurbishment of the following equipment only:

- Stacker Reclaimer 3 and Tripper Car 3

The critical success factors for the completion of FEL 4 are:

- On-time funding approval
- No procurement delays
- Comprehensive risk analysis and evaluation with mitigations in place
- Execution delivered on time and to budget
- A well-defined mitigation plan that engages all stakeholders resulting in no volume losses
- Zero H&S incidents

A Post Implementation review (PIR) will be carried out on the equipment to assess the success of the project. PIR factors:

- Availability >95%
- Reliability >98%

The benefits of the project are:

- Sustained terminal volume throughput and income
- Long term viability of the terminal
- Reduction in downtime
- Reduction in breakdown frequencies
- Achieve machine end of life
- Safe and reliable terminal
- Savings in maintenance costs

2. Introduction

2.1 Purpose

The purpose of the Construction Management Plan (CMP) for the Bulk Terminal Saldanha, Equipment Refit, is to define the methods and construction management elements that will be used to effectively manage the execution of the works at the terminal within the confines of the Business Case and Owner Requirement Specification, and also contains a framework for the successful execution of the construction activities by the Project Team.

The CMP establishes the execution philosophy and defines the organisation, work processes and systems necessary for execution of the works.

- The information outlined in this document is used to help ensure that the project is executed and completed in a timely and efficient manner and that the facilities designed and constructed will satisfy the project functional requirements.
- The CMP is structured to provide control over the execution and the requirements for each phase/discipline in the project.
- The CMP is a working document and is updated and detailed as the project progresses through the execution phases of construction, commissioning, proofing and hand over.
- The CMP is designed to always have the latest information available. It is the Project Manager's and Construction Manager's responsibility to update this document and to ensure that the latest information is available.

This CMP is complemented by the following separate documents:

- Owner Requirements Specification;
- Operational Readiness Plan (volume mitigation plan);
- Project Execution Plan;
- Project Health and Safety Management Plan;
- Project Environmental Management Plan;
- Quality Management Plan;
- Project Schedule;
- Security Management Plan;
- Project Risk Register;
- Project Legal Register;

2.2 Scope

The scope of this document includes:

- Construction Management prior to site establishment, up to the completion of commissioning/handover and site close-out;
- The responsibilities of the Construction Management Consultant (CMC)- and Support Services Team;
- The responsibilities of the Principal Contractor and his subcontractors;
- The responsibilities of the Client;
- Processes for Site Administration;

In line with Transnet Port Terminals' (TPT's) Owner Requirement Specification (ORS) the refurbishment is to ensure that the Bulk Material Handling equipment reaches end of life and to ensure that the machinery is safe for operation for the remainder of the operational period.

The majority of the equipment and structures at this terminal has passed their mid-life and require extensive repairs.

This FEL-3 report provides details for the refurbishment and repairs of the terminal. It has been decided to split the execution works into 4 distinct phases:

- Phase 1: Ship Loader-2 and Stacker Reclaimer-2 (Base Case approved)
 - Phase 2: Ship Loader-1 and Stacker Reclaimer-4 (Base Case approved)
 - Phase 3: Stacker Reclaimer 1 (Base Case approved)
 - Phase 4: Stacker Reclaimer 3 and Tippler 2* (This submission)
- *Tippler 2 is dependent on the completion of Tippler 3 and as such will be executed via a separate BCase

2.3 Document Status

This is a live document that will be updated periodically during the Construction Execution Phases when required.

3. Construction Management prior to Site Establishment

3.1 General Site Description

The Saldanha Terminal on South Africa's West Coast is the country's only dedicated iron-ore terminal. The Saldanha port is linked by rail to key iron-ore mines in the Northern Cape, making it the ideal gateway for the export of seaborne iron-ore.

The Saldanha Terminal is comprised of two operational terminals, namely the Bulk Terminal (BTS) and the Multi-purpose Terminal (MPT) (refer Figure 1 below).



Figure 1. Saldanha Terminal - BTS in the foreground and MPT top right

The MPT is currently a four (4) berth facility that handles a mix of commodities including dry bulk and break bulk cargo for both import and export. The BTS is a specialized iron ore export facility with dedicated equipment for offloading (from rail), storing and exporting (loading onto ships) different grades of iron ore. The iron ore capacity at the BTS is sixty (60) million tons per annum

The BTS's bulk handling equipment includes:

- Two (2) Tandem rotary tippers;
- Four (4) Stacker-reclaimers (SR) (Figure 2);
- Two (2) Ship Loaders (SL) (Figure 3); and
- Twenty five (25) inter-connected conveying belts.



Figure 2. Stacker-reclaimer at BTS



Figure 3. Ship loaders at the BTS

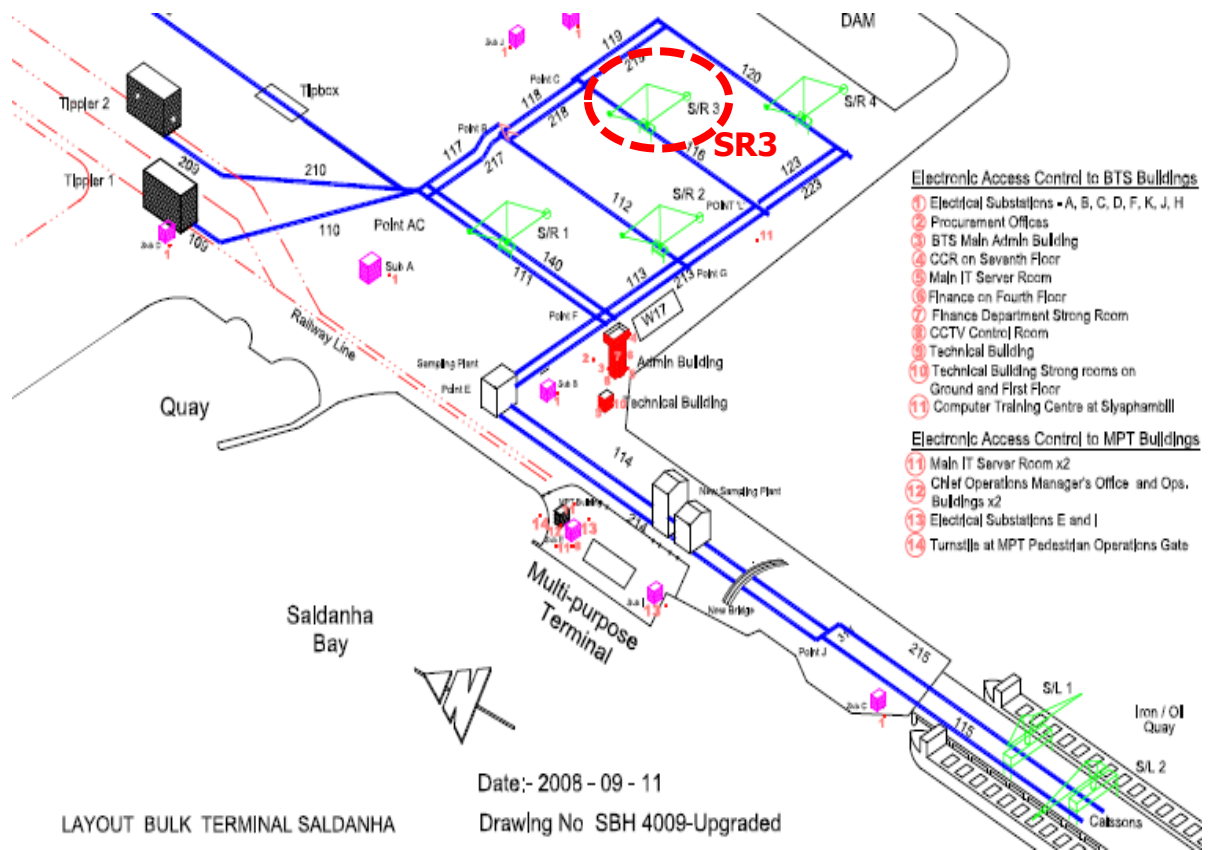
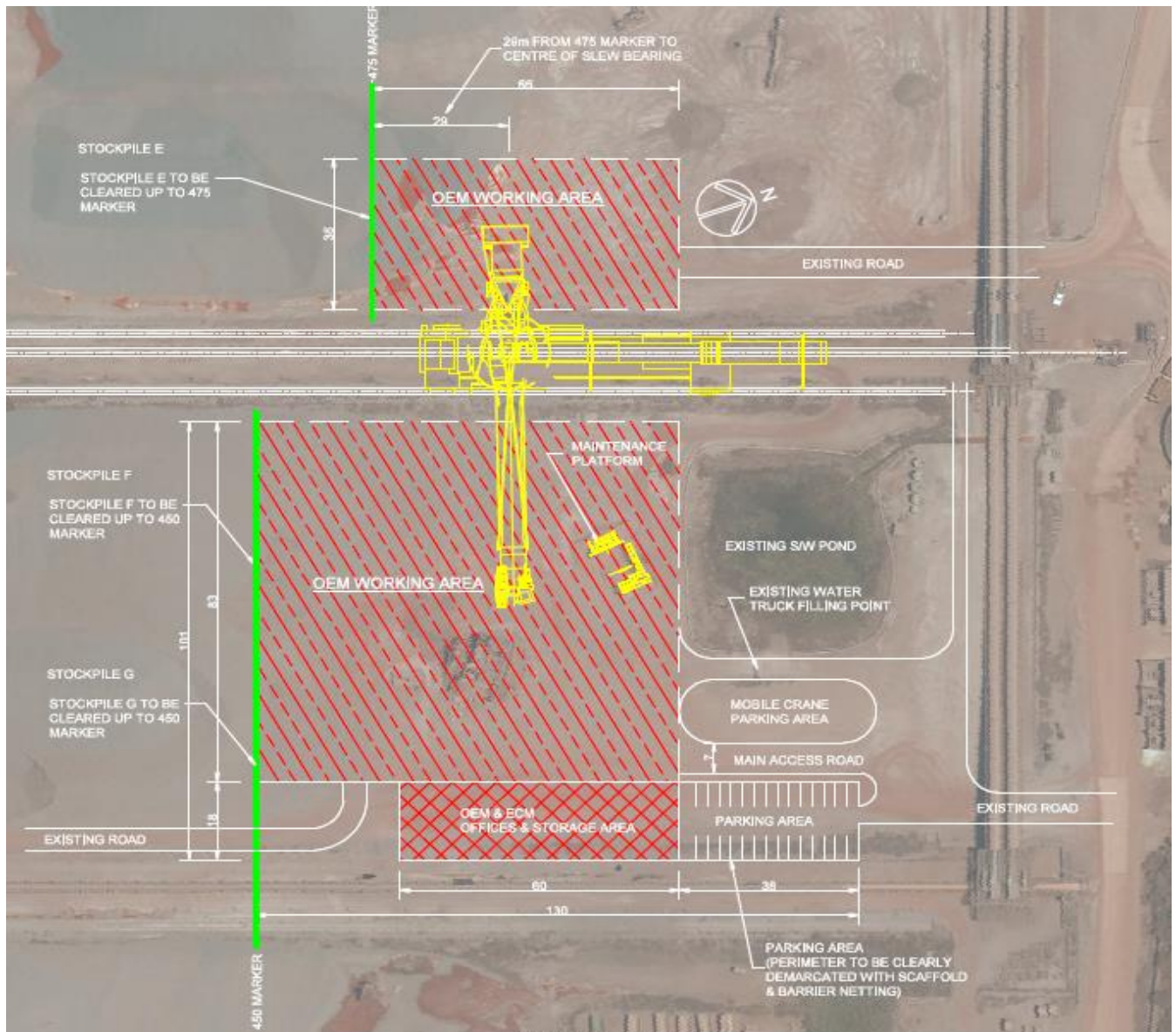

Figure 3. Schematic layout of the Saldanha Bulk Terminal

3.2 Contractor Site Establishment & Traffic Management

The Contractor's site offices, ablutions and minor stores may be located on site at identified areas and sited to not hinder work or operational activities. Final yard and lay down areas to be determined prior to construction.



BTS EQUIPMENT REFIT :
 SITE LAYOUT (2021-2022 SHUT) STACKER RECLAIMER 3 & TRIPPER CAR 3
 (SCHEMATIC SITE LAYOUT - NOT TO SCALE)
 DATE: 24/08/2020

SR3 laydown area and site facilities

A site walkabout was scheduled with the BTS Operations- and Safety/Security Management teams where potential areas for site establishment and lay down areas for material and equipment, were identified

The surrounding existing infrastructure poses a major limitation on lay down space available for storing of materials. The contractor will need to take cognisance of this fact when planning the works and delivery of materials. Principal Contractors to submit traffic control plan and allow for flagmen to manage. There is no anticipated major traffic disruption on the Port main route from and to the construction area.

3.3 Site Office Facilities

The Project Administration and Management Team will be based at the existing Technical Building of the BTS. This office is suitably equipped to provide full functionality for the Project Team, TPT Project Manager, CMC Project Manager, Project Planner, Document Controller, etc.

The Site Supervisory Team; Construction Manager, Supervisors and Safety, Environmental- and Quality Officers will be located in container site units, placed on site at the designated areas.

3.4 Project Schedule

A project execution schedule has been provided detailing the sequence of events. The project schedule has been structured to include all project milestones. The Basis of the Schedule is included within the FEL 3 reports doc. no. Z.5200160-BOS.

The following milestone dates are supported in the presented schedule.

Key Milestones	Date
2020 Milestones:	
Gate Review	15 February 2021
CAPIC Approval by	31 March 2021
2021 Milestones:	
Contract Award by (Principal Contractor & CMC)	31 July 2021
Site Establishment Start	20 September 2021
Execution Start	27 September 2021
Cold Commissioning Complete	09 October 2021
Hot Commissioning Complete	11 October 2021
Sectional Close Out 2021 Complete	30 November 2021
2022 Milestones:	
Site Establishment Start	31 August 2022
Execution Start	13 September 2022
Cold Commissioning Complete	15 October 2022
Hot Commissioning Complete	18 October 2022
Sectional Close Out 2022 Complete	30 November 2022



Key Milestones	Date
2020 Milestones:	
Gate Review	15 February 2021
CAPIC Approval by	31 March 2021
2021 Milestones:	
2023 Milestones:	
Deliver of Spares/Refurbished Components	31 July 2023
Final Close Out Complete	30 November 2023

3.5 Scope of Works

The High Level Deliverables for the FEL4 execution (Phase 4 refit) include:

1. Execute volume mitigation plan agreed with Clients
2. Procurement and contract award
3. Manage execution of the work & ensure adherence to Transnet's standards & procedures
4. Test, commission and certify completion of the works
5. Draw up project close-out documentation

The tables below list the high level scope of works to be completed during the FEL4 execution:

STACKER RECLAIMER 3:

EQUIPMENT REFIT PROJECT (PHASE 4) STACKER RECLAIMER 3			
SOW No	DESCRIPTION	Sum/No	QTY
1	<p>Preliminary and General, project management and overhead costs, all labour, crantage, equipment, vehicles, tools, access requirements, assessing free issue equipment, civils works for site establishment and execution of works, also including meeting the requirements of Health & Safety, Environmental, Quality, Construction Management, Execution and Commissioning, as stipulated in the Scope of Work</p> <p>Includes for any training/familiarization of installed equipment</p> <p>Contractor to provide a detailed cost breakdown for this item.</p>	Sum	1

2	SR3 & TC3 high pressure Cleaning	Sum	1
3	Boom tip repair (Including replacement of Wear Bars)	Sum	1
4	Replace Wear bars on Boom Tip	Sum	1
5	Drive/Idle wheel assemblies (New)	No.	8
6	Drive/Idle wheel assemblies (Refurb)	No.	8
7	Single Idle Wheel assemblies for tripper car (New)	No.	5
8	Single Idle Wheel assemblies for tripper car (Refurb)	No.	5
9	Double Idle Wheel assemblies for tripper car (New)	No.	4
10	Double Idle Wheel assemblies for tripper car (Refurb)	No.	4
11	Wheels for SR (Drwg 700520). All remaining wheels to be replaced	No.	64
12	Centralised Automatic Lube System - refurbish	Sum	1
13	Travel Brakes. Supply and install (supply 32. i.e 48 less the 16 supplied with the wheel assemblies)	Sum	1
14	Slew Drive Reducers (set of 3)	Sum	1
15	Slew drive reducers - 3 x spare	Sum	1
16	Bucket Wheel Installation. Contractor to install complete bucket wheel system. Components free issue from terminal.	Sum	1
17	Refurb old Bucket Wheel & Receiving chute	Sum	1
18	Hose reel.	No.	1
19	Rail Clamps.	No.	2
20	Operator Cab (Stainless steel Cab)	No.	1
21	Operators Chair	No.	1
22	S/R T Bar Festoon	No.	1
23	Slew Cable Carrier	No.	1



24	Main Power Cable Reel	No.	1
25	Slew Drive VFD's (1 x Set)	Sum	1
26	Travel Drive VFD's (1 x Set)	Sum	1
27	Bucket wheel VFD Only (1 x Set)	Sum	1
28	VFD spares	Sum	1
29	Main PLC Enclosure	No.	1
30	3D scan	No.	1
31	Boom/incline/Tripper idlers support frames - replace all. 1 x set as spare	Sum	2
32	Corrosion Protection (SR and Tripper car)	Sum	1
33	Pr Eng Signoff of support trestles	sum	1
34	Containers for storage of long lead items on site (will become BTS property)	No.	6
35	Luffing cylinder, manifold. Replace with new. Supply x 1 spare with stand and test pack.	No.	2
36	Structural/weld repairs	Sum	1
37	Boom Conveyor Drive Train. Supply and install 1 x set. Supply 2 x spare	No.	3
38	Incline Conveyor Drive Train. Supply and install 1 x set. Supply 2 x spare	No.	3
39	Boom and Incline Conveyor Pulleys. Supply and install 1 x set. Supply 2 x spare	No.	3
40	Supply and replace Obsolete Simmocode Modules in the Gantry MCC	Sum	1
41	Fire Escape DAVIT system to Operators Cabin	Sum	1
42	Replace Air conditioning within Gantry E-House & Seal Roof	Sum	1
43	Refurbish Dust Suppression System	Sum	1

4. Construction Strategy

4.1 General Construction Execution

The Principal Contractor is required to comply with all Health and Safety, Environmental, Quality, Security, Industrial Relations and other procedures as specified in the Works Information. Management of these procedures will be undertaken by the CMC Contractor under the control of the TPT Project Manager.

4.2 Construction Methodology

Construction is to be carried out in an approach that will minimize disruption to site activities. Schematic layout of the Saldanha Bulk Terminal in Section 3.1 shows the Terminal Layout for the iron ore export facility, with the highlighted sectors showing the area for the Phase-3 project.

The refurbishment of the equipment/infrastructure will ensure that TPT is able to maintain the existing iron ore export volumes. This will also ensure that the plant and machinery are safe for operation. The contractors will be required to comply with all relevant construction industry standards as specified or at the very least "good engineering practice".

4.2.1 Outage Plan

The terminal has one maintenance shutdown period per annum for major maintenance and conducts 2 x 12-hour maintenance windows per month (per equipment) for less intrusive work.

The current proposed annual outage for 2021:

- 10 days: 28 September 2020 – 07 October 2020

The 10 day maintenance shut of 2021 is co-ordinated between TFR, TNPA, TPT, Shipping lines and mines and is unlikely to change. To minimize overall impact to throughput export volumes, the equipment refit project has been phased (phase 1-4) and will coincide with the 10 day annual shut.

It is anticipated that there will be volume losses generate by the equipment refit phases and these will be mitigated by exporting via the Multi-Purpose Terminal (MPT)

For details of the mitigation actions, refer to the Mitigation Plan see Z.5200160-MP.

4.2.2 Construction Sequencing / Details

The work will be carried out in accordance with all Contractors schedule of works to be submitted, assessed and accepted by the TPT Project Manager.

This Schedule, level 5 Microsoft Projects, hourly schedule is to comply with all stipulations contained within the procurement document requirements and shall show clear logical methodology and the critical path for undertaking of the works within the stipulated time constraint.

Careful planning and attention to detail will ensure timely and successful completion of the works and that projects objectives are met.

The construction sequencing is to advise the contractor of the approach in minimising disruptions to operations carried out at the Port, this does not limit the contractor to execute work as per this document, it only serves to inform the preferable approach, and this is subject to change as the project approaches execution, to suit any site changes and arrangements.

4.2.2.1 Construction effect on operations

This section covers the construction effects on the current productivity of BTS for the Port of Saldanha; for further details refer to the Mitigation Plan (Z.5200160-MP) for each activity that directly effects operations.

Stacker Reclaimer 3

There are four Stacker Reclaimers positioned in the BTS stock yard, during phase 4 The impacts on operations will be:

- Mitigation for volume losses will lead to machinery and trucks to load and transport iron ore, from the Iron Ore stockyard to the MPT for export.
- The stock yard will need to be reconfigured.
- Stockpile E, F & G is to be cleared to the 450 & 475m marker. This is to allow enough space for the construction area. (refer to figure in section 3.2, for further clarification)
- A stockyard management plan will need to be agreed upon to reflect the stockyard management requirements prior to and post the equipment refurbishment project.
- A demarcated lay down area will be required within SR3's stacking area
- Impact for delivering large equipment needs to be co-ordinated with operations.
- SR3 construction site will be demarcated, and access will be restricted

- SR3 to be placed in a secure maintenance state

4.2.3 Construction precautions

The following measures will be put in place when refurbishing the various components in the Bulk Terminal of Saldanha.

- Each refurbishment area will be demarcated from operations during refurbishment
- The demarcated area will be the responsibility of the Principal Contractor with regards to safety and construction procedures (TPT safety, environmental and CMC construction manager will be available on site to oversee compliance).
- The Principal Contractor must align to all the environmental policies of the Port (Disposal of material and spillages must be dealt with in a way that doesn't compromise the environmental standards of the workshop).
- Environmental & Safety personnel will always be available on site to ensure good practice is met by the contractors.
- It is recommended that, in coordination with Operations, fixed, planned timeslots in which construction and material delivery vehicles can access the construction area be established. This will ensure minimum interactions with operational vehicles.
- It is recommended that there should be controlled vehicle access to the site.

4.3 Material Supply

4.3.1 Materials Supplied by the Contractor

The Principal Contractor will be responsible for the management of all materials for the execution of the works.

4.3.2 Materials Supplied by Transnet

Transnet will issue some materials free of charge. The responsibility for their storage remains with the Principal Contractor.

5. Construction Phase

5.1 Kick-off meeting with Principal Contactor

Upon signing of the contract, the Project Manager conducts a kick-off meeting with the Principal Contractor. The purpose of this meeting is to:

- Introduce the TPT Project-; CMC- and Contractor's teams.
- Discuss Transnet's policies and procedures;
- Further emphasise the Safety, Environmental and Quality requirements;
- Highlight salient aspects of the project;
- Discuss contractual obligations of the parties;

- Issue of AFC drawings, where applicable;
- Issue of contractual and procedural templates;
- Discuss induction and access requirements;
- Requirements for the approval of the Principal Contractor's *Contractual Documentation*, prior to site access being granted, covering the following;
 - Site Mobilisation Plan
 - Safety Management Plan and Safety File
 - HAZOP studies (if required), Risk assessments, with mitigation plans and method statements,
 - Emergency Management Plan,
 - Industrial Relations Management Plan,
 - Security and Access Control Plan,
 - Quality Management Plan, with detail on QCP's, hold points and sign-off requirements
 - Detail Execution Schedule and progress management,
 - Site Execution Organigram, staffing, appointments and contact administration,
 - Risk Management
- Reinforce the use of proper communication channels;
- Highlight early procurement of all resources required to execute the works;
- Discuss mitigating measures of any risk items that may occur early in the contract;
- Emphasise the need for team work for the successful completion of the project.
- Finalise constructability with inputs from Client- and Project teams.
- Proposed meeting schedule and general communication.

5.2 Construction Facilities

5.2.1 Site Camp, laydown areas and Offices

The Contractor shall be responsible for the establishment of his site camp and arrangements for accommodation. Principal- and other Contractors to allow for all site facilities required, on construction site and site offices areas, as none will be available nor supplied by the Client. No living accommodation will be allowed inside the boundaries of the Port of Saldanha. The establishment must be in accordance with Transnet's Environmental and Safety Requirements.

5.2.2 Access

Access to site is available through the existing road network in the Port of Saldanha and via the TPT Terminal Control and Security at the Port of Saldanha Terminal. All TPT Security Policies will be strictly adhered to. The transport of Contractor's staff on open vehicles is not permitted on Transnet property.

5.2.3 Parking

Allowance to be made for enough, safe parking for all construction-, LDV- and other vehicles at the construction site and yard. Only reverse parking allowed.

5.2.4 Construction Water

Contractors will be responsible for obtaining the necessary water for construction purposes from tee-off points from the existing TPT supply pointed out by the Construction Manager. Enough and clean drinking water required for site staff must be supplied by the contractors in hygienic, auto-cooled, water bottles/containers.

5.2.5 Construction Electricity

Contractors will be responsible for making provision for all their electrical/power requirements and provide Gensets with refuelling requirements at their own cost for the duration of the construction period. The Principal Contractor is to install his own distribution box, to provide enough power for all contractor's requirements for welding, other heavy engineering works, site offices and area lighting requirements. This installation to be supported by Certificate of Competency (COC) obtained by Principal Contractor and submitted to the appointed Electrical Engineer from BTS.

5.2.6 Construction Waste Management

The contractors will be responsible for providing their own facilities to handle, contain, and dispose of both hazardous and domestic waste materials. This will be required for the duration of the construction period. The storage of oils, materials, chemicals, fuels and other to be used during the construction phase must not pose a risk to the surrounding environment. Temporary bunds must be constructed around chemical or fuel storage areas to contain possible spillages.

Sustainable management of waste through the waste hierarchy - reduce, reuse, and recycle. Any material waste will be disposed of in accordance with the requirements of the TPT Environmental and Waste Management procedures.

5.3 Management of Construction Issues

The key components of the construction strategy will be the following:

- Developing a safe working culture and environmental awareness on the construction site, adopting the approach and behaviour of "Zero Harm".
- A contracting strategy that allows for mobilisation of specific and specialist construction contractors and employees.

- Establishment of an CMC construction team under the leadership of the TPT Project Manager, which manages all aspects associated with the construction effort on the construction site.
- Working closely with the Bulk Terminal Saldanha (BTS) representative members to minimise disruptions to ongoing operations.
- Proper liaison and communication with all necessary stakeholders and role-players.

5.4 Constructability

5.4.1 Background

This project consists of the refurbishment of equipment to be reinstated to its original condition. The equipment will not be upgraded to allow for any increases in volume throughput. The replacement of components will be on a 'like for like' basis only and as such there will be no design work involved.

During the scope clarification meetings with the Client Team, BMH Specialist and TPT Project Manager, the team members have reviewed and provided constructability inputs to the planned execution in the areas of construction safety, construction methods, labour, materials and quality requirements in order to meet the objectives of safety, cost, schedule and quality. For further information refer to applicable FEL3 documentation.

Particular attention to finalise constructability aspects regarding the execution of the project will be provided during FEL4 stage. More detailed information, which will be used as inputs to finalise the constructability will be requested from the Principal Contractor as part of the tender returnable documentation. This will be included; project schedule, method statements, resource planning and Quality plan. Thus, constructability will be reviewed upon receipt of the Contractors tender documentation, prior to appointment.

The refit project, to be planned and executed in such a manner, to ensure minimal impact on the present operations, thereby ensures that the planned 60 million tons per year be handled by the Iron Ore Facility. For detail on planned mitigation of project impact, see project mitigation plan.

5.4.2 Client/BTS Operational Interfaces

All involved, Principal Contractor, other Sub-Contractors, Project Team and CMC Construction Team to understand the needs, objectives and technical requirements of the Client/BTS and the Refit Project.

Incorporate the client's internal procedures into the Construction Site Procedures

Ensure client representation and involvement in the following discipline areas:

- Health, Safety and Environmental
- Industrial Relations
- Security Management
- Technical and Quality
- Contractual Matters

Key individuals from Client to attend project meetings.

Special work permits are required when project work are executed, that might have an impact on the client's/BTS operations.

No work to be allowed within one metre of any structure supporting a conveyor that have not been locked out and permit with permit number issued to cover the scope of planned work.

The following permits. Signed-off by the client, need to be in place;

- Site establishment/mobilising permit.
- Permit to commence with Construction/Refurbishment work.
- Special Permit to execute work that might interfere with client's/BTS normal operations or that are within one metre of any conveyor.
- "Hot Work" and "Confined Space" working permits.
- Site de-establishment/de-mobilising permit.

5.4.3 Support to Contractors

The following will be provided by the Project Team:

- Full support to all contractors and sub-contractors to ensure a successful project outcome.
- Provide the necessary support to ensure that the Quality Control system, including the inspection and test plans and quality verification documents are not only implemented, but are being executed to provide a quality project.
- Review contractor's purchased material for compliance to specifications.
- Review of all method statements from all contractors for accuracy, completeness and suitability for the intended application.
- Support in project controls to ensure that realistic and achievable schedules, scopes of work and progress units are being assigned.
- Manpower requirements will be evaluated based on approved schedule to ensure that the project objectives are met.

- Provide safety induction for contractor's personnel and monitor the activities of the contractor's safety representatives.

5.4.4 Health and Safety Management

The appointed H&S Agent will also review, together with the TPT Project Team, the Contractors H&S documentation to ensure that H&S during execution is adequately addressed.

Safety meetings will be held, and Safety Audits shall be conducted by Safety Agent.

Construction will be done in accordance with the approved Health and Safety Management Plan (Z.5200160-HSMP), contained in the FEL 3 documentation.

5.4.5 Environmental Management

Construction will be done in accordance with the approved Environmental Baseline Report (Z.5200160-EBR), contained in the FEL 3 documentation.

5.4.6 Quality Management

Construction will be done in accordance with the approved Quality Management Plan (Z.5200160-QMP), contained in the FEL 3 documentation.

5.4.7 Engineering and Method Statements

Engineering Execution Plans, supported by HAZOP studies (where applicable), and detail method statements, for all major Structural, Mechanical, Electrical Control and Instrumentation Engineering *works*, with to be submitted by the Principal Contractor, as prescribed in the tender documentation.

5.4.8 Security and Access Control

Security and access control will be implemented in accordance with the approved Security Management Plan (Z.5200160-SMP), contained in the FEL 3 documentation.

All Contractor's- and Construction Management personnel will require access to the construction site and will be subject to the process of induction and identity badges.

The contractor shall comply with the specific access requirements as dictated to by the Port of Saldanha Terminal, as well as any specific requirements which may be imposed by TPT. The Port of Saldanha Security and Site Access requirements will apply to this project, as work will be undertaken within the operational terminal. The contractor will however be required to implement the necessary security measures to protect both the

site and facilities during the construction period and is therefore required to secure their own works until final acceptance.

5.4.9 Industrial Relations

The management of Industrial Relations is deemed to be significant in order to ensure adherence to legislative requirements and to maximize the likelihood of Project Completion without any unplanned work stoppages due to Industrial Actions. An Industrial Relations Plan will be a requirement in the enquiry documentation and this will be used by the Contractor to manage industrial relations.

5.4.10 Communication Management

Communication will be done in accordance with the approved Communication Management Report (Z.5200160-CMR), contained in the FEL 3 documentation.

5.4.11 Risk Management

A Project Risk Register has been compiled and will be reviewed and updated at the commencement of the FEL-4 phase of the project and will form the basis of the project risk management. The risk register will be reviewed monthly during project meetings. Risk workshops will be held, attended by all specialist discipline leads and chaired by the TPT Risk Manager. Risks and early warnings will form part of the daily feedback meetings during execution.

Risks will be managed in accordance with the approved Project Risk Report (Z.5200160-PRR), contained in the FEL 3 documentation.

5.4.12 Interface

Close interface shall be required from the project team and the principle contractor's team during construction of the works to mitigate against any possible risks.

Daily meetings will be held between Project, Client, CMC, Principal Contractor teams to discuss Safety, Quality, Progress, Risks and interface issues and agree on remedial actions.

5.4.13 Procurement

Procurement will be done in accordance with the approved Procurement Report (Z.5200160-PR), contained in the FEL 3 documentation.

5.4.14 Sub-Contracting

All construction contractors are required to give preference to the employment of local labour. The Principal Contractor shall be responsible for managing and maintaining his own labour force.

5.5 Construction Execution Plan

5.5.1 Prior to Site Establishment

- Construction Planning
- SHE Policy and strategy
- Engineering and Procurement
- HAZOP studies (if applicable)
- Constructability
- Works information
- Organisation and Manpower Plan
- Site Facilities Plan
- Execution planning with focus on Safety & Risk mitigation

5.5.2 Construction Site Establishment Phase

- PC to submit and get approval for site establishment plan
- Clear Responsibilities of all involved with project
- Site Mobilisation
- PC site establishment control and appointments
- Site Handover to PC to commence with execution

5.5.3 Integration with Functional Areas

- Health, Safety & Environmental Management
- Industrial Relations
- Site Security and Access Control
- Emergency Management
- Site Engineering
- Construction Planning and Progress Measurement
- Site Logistics and Expediting
- Quality Control
- Cost Management
- Contract Administration
- Risk Management

- Site Administration
- Document Control

5.5.4 Commissioning, Testing and Handover

Commissioning, testing and handover will be done in accordance with the approved Commissioning Plan (Z.5200160-CP), contained in the FEL 3 documentation.

5.5.5 Site Demobilisation and Close-out

As soon as the Works have successfully passed any required Performance/Acceptance Test with only Category 'C' Punch List Items remaining with a commitment to complete the Category 'C' Punch List Items by an agreed date during the Defects Correction/Warranty Period and following the application by Contractor for a Completion Certificate, a Completion Certificate will be issued.

PC may commence with demobilisation and close-out of site, once he received a fully signed Completion Certificate.

- On completion of demobilisation, site cleaning and reinstated all areas to original state as received, the PC may apply for a "site de-establishment/demobilising permit", confirming that all requirements for demobilisation were met.

6. Roles and Responsibilities

6.1.1 Construction Management Organisation

The project organisation is shown on the project organogram, figure 3.

See figure 4, for the proposed Organogram for the CMC construction site execution team disciplines. Names will be linked to disciplines once the CMC is appointed.



Figure 3: Project Organogram

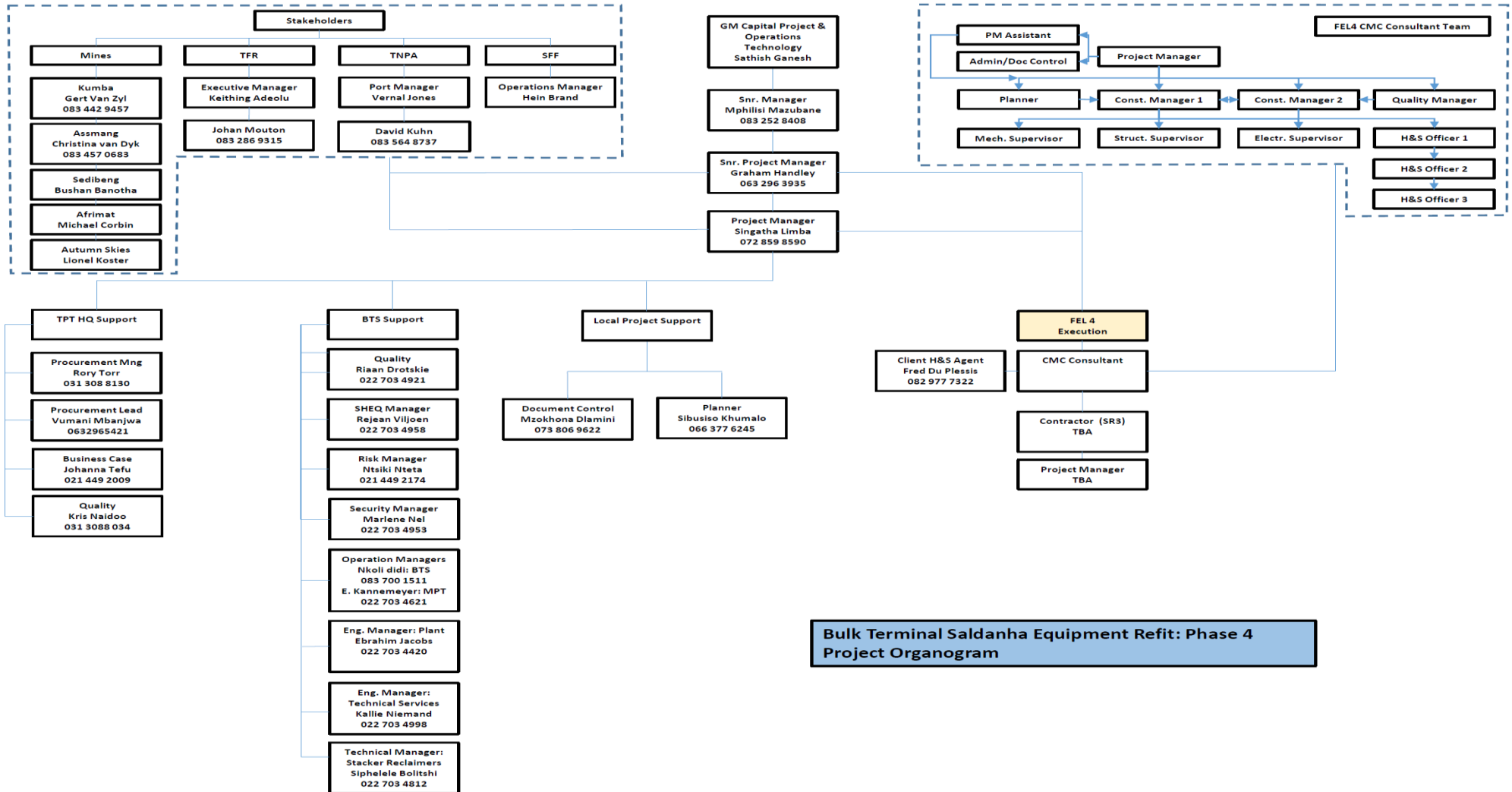

**Bulk Terminal Saldanha Equipment Refit: Phase 4
 Project Organogram**



Figure 4: CMC Site Execution Team Organogram

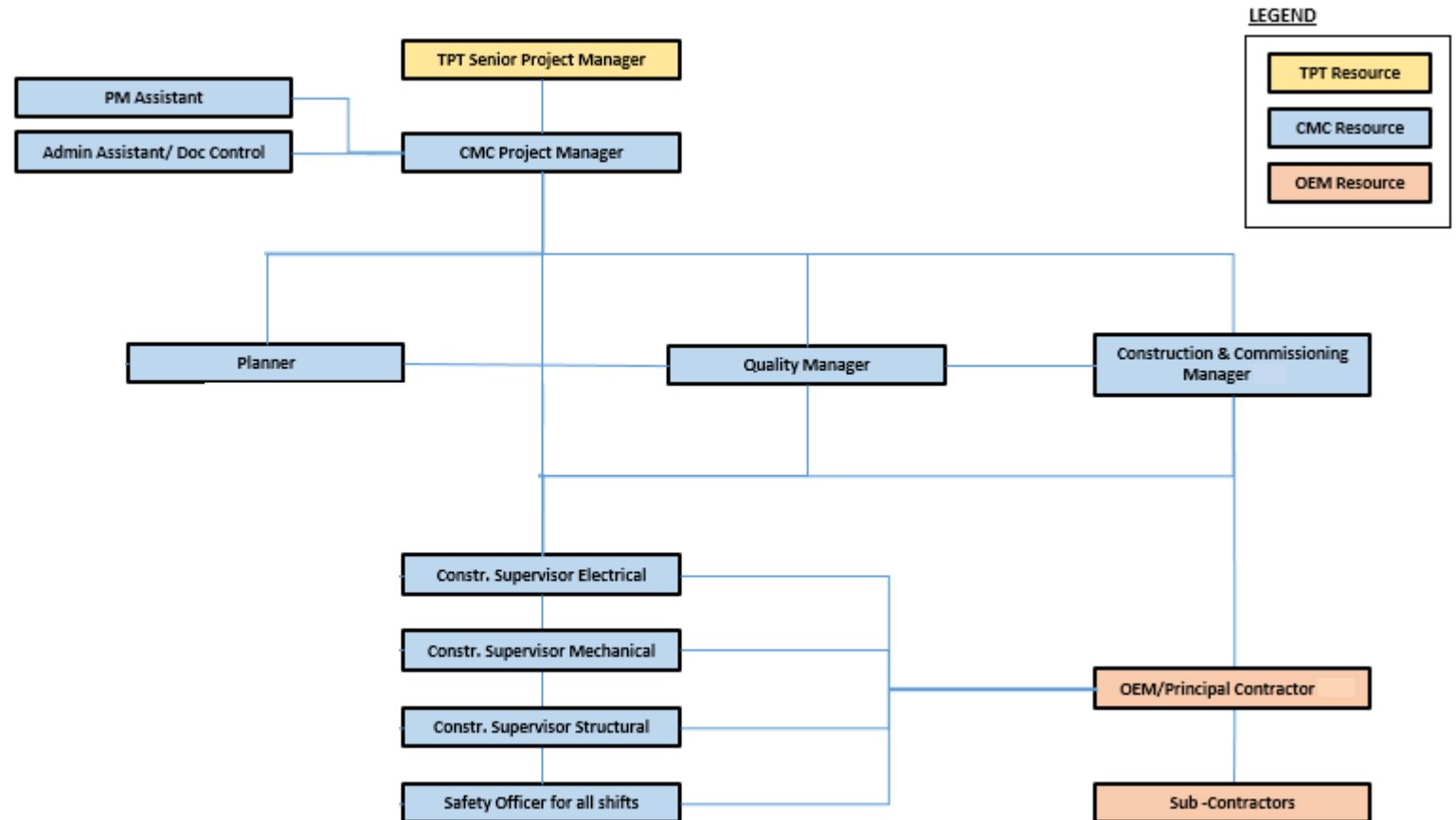

6.1.2 CMC Project Manager

The Construction Management Consultant, Project Manager is responsible for the overall execution management of the Phase-4 refurbishing project and reports to the TPT Senior Project Manager.

6.1.3 Construction Manager/Commissioning Manager

The key responsibilities of the Construction Manager are:

- Health and Safety during Construction
- Environmental Management
- Technical Compliance with Works Information and execution of SoW within cost- Time- and Quality constrains.
- Completion of all site works and hand-over completed project for Commissioning.
- Integration- and communication support to all involved during construction
- Risk Mitigation
- Industrial- and labour relations harmony

Prior to and during the construction phase, the Construction Manager is responsible for:

- Ensuring that the necessary records are kept.
- Organising site mobilisation.
- Ensuring adequate supervision and monitoring of the Works and the Contractors on site.
- Establishing and managing, supported by the Site QA/QC co-ordinator, an efficient Quality Management Programme.
- Managing, supported by the site contract administration staff, the commercial aspects of the contract and compensation events.
- Managing, supported by the assigned Health and Safety Practitioner and Environmental Officer, the co-ordination of Health, Safety and Environmental policies and procedures.
- Managing site administration
- Reporting to the Project Manager any deviations from Policies/Procedures that arise.
- Verifying construction progress reports issued by the contractor.
- Leading the project construction closeout process.
- Interfacing with third parties.

The Construction Manager shall ensure that the Principal Contractor's Safety File; Safety Management Plan, inclusive of all required documentation are in place and approved by TPT Project Manager and BTS Client, prior to the issuance of the Certificate.

6.1.4 Site Supervisors

Site Supervisors will be appointed, under the guidance of the Construction Manager and will be responsible for all daily activities under their control, including Safety-, Environmental-, Quality- and Progress Management.

Site Supervisor's responsibilities also extends further as described in the NEC3 suit of contract documentation and the latest Construction Regulations.

6.1.5 Site Quality Assurance Officer/Manager

The Site Quality Assurance Officer is responsible for:

- Preparing and maintaining internal audit schedule.
- Schedule enough audits to cover all functions of the project.
- Plan, prepare and conduct internal and external audits.
- Identify and initiate corrective action and monitor progress.
- Prepare corrective action/non-conformance and summary reports.
- Analyse data on quality related trends.
- Identify general areas for continuous improvement.
- Assist with the evaluation and assessment of potential suppliers to ensure compliance of contractors, suppliers and vendors.
- Compile assessment reports.
- Implementation of the Site aspects of the PQP in consultation with the Construction- and Project Managers.
- Coordinating the preparation of Field Inspection Packs (FIP) in preparation for pre-commissioning testing.
- Liaising with Contractor QA/QC personnel.
- Coordinating TPT's field inspections, sampling and testing activities identified in the Contractor QCP.
- Interfacing with Client Site representatives and any third-party inspection agencies on QA/QC matters, e.g. field survey activities.
- Coordination of Site QA / QC records, including:
 - NCR's, QIR, concession and deviation databases;
 - FIP's and field inspection checklists;
 - Inspection and NCR reports, etc.;
 - Contractor QCP;
 - Test results, etc.;
 - Mark-ups of P&ID's to record inspections;
 - Witness SAT requirements;
 - Check Data Books.
- Ensure adequate Site document controls are implemented and maintained.
- Assisting with the development of the project QC Inspection Schedule.

- Preparation and implementation of QC inspection procedures.
- Ensure that the required intervention points are identified in the Contractor QCP's and attended to ensure that the "Designers" fulfil their obligations are met.
- Identify the requirements for inspection agencies and inspection staff.
- Coordination of inspection resources (local and agency) including allocation of inspection assignments in accordance with the QC inspection plan.
- Ensure inspection resources are fully aware of respective Supplier inspection Scope of Work/Services, and Supplier specified QC requirements.
- Liaison with Procurement expeditors, with particular attention to managing QC aspects associated with the release of Supplier product.
- Review and distribution of inspection reports, and inspection releases.
- Work in conjunction with the respective discipline engineering leads to expedite and resolve issues identified during inspections.
- Coordination and expediting the resolution and distribution of Supplier non-conformance reports.
- Facilitation and coordination of Supplier pre-inspection meetings.
- Coordinate periodic audits of Supplier QC records and project audits to ensure compliance with approved working procedures and processes.
- In conjunction with the Engineer set up and maintain the QC records tracking system and ensure records of all inspections are maintained as well as non-compliance items.
- Manages the Quality Incident Reports, (QIR), Non-Conformance Reports, (NCR), from issue to close-out and maintain a NCR Register.
- Recommends and follows up corrective actions to prevent internal or external deficiencies.
- Provide representation at site contract meetings with respect to QA/QC matters.
- Supports the Change Management Process, FEQ's, Concessions, DCN's, PCN's, etc.
- Reports to the Construction Manager and Project Quality Manager the status of Quality Management on a monthly basis.

Quality Management shall be carried out ensuring compliance with the approved Project Quality Plan (PQP), Quality Control Plan (QCP) and any specific requirements as detailed in the Works Information.

6.1.6 Health and Safety Officer

The Health and Safety Officer shall be responsible for, the items listed below for the areas under his responsibility during the shift worked:

- Site inspections
- Monthly audits
- Incident investigation

- Ensure contractors comply with the HS plan
- Monitor compliance to the established safety management system
- Ensure compliance with any other relevant acts, regulations and standards
- Be registered with SACPCMP or provide proof of registration progress.

In addition to the above:

- Assist with training for all levels of employees on health and safety procedures.
- Prepare induction content and assist with the preparation of other H&S training programme.
- Prepare and update emergency and other H&S procedures in conjunction with the Health and Safety Manager.
- Check all work procedures and method statements before they are issued to ensure that safety aspects of the operations are covered in accordance with the requirements of the HSE Plan.
- Promote awareness of injury prevention and damage control to all levels of employees.
- Keep up to date with the recommended codes of practice and new safety literature and circulate information applicable to each level of employee.
- Chair the H&S weekly meetings.
- Issue non-conformance reports for serious irregularities observed on site.
- Implement and administer Transnet Port Terminals safety procedures.
- Conduct monthly compliance safety audits, with Safety Agent.
- Assist the Project / Construction Manager in resolving conflicting requirements.
- Participate in Project Specific Risk Assessment and ensure that the Health and Safety Specification submitted to Contractors includes Project and Contract specific Health and Safety aspects.
- Verify that Contractors have prepared their Health and Safety Plans in accordance with the Health and Safety Specification, and arrange for the Construction Manager, Project Manager and Health & Safety Agent to approve the Health and Safety Plan.
- Arrange for the Project Specific Induction Training to be given to all Transnet Port Terminal Projects staff, Contractors and Visitors and facilitates Health and Safety Training Assist Construction Supervisors to continuously verify compliance by Contractors to Health and Safety requirements.
- Analyse Health and Safety performance and advice the Construction Manager and Project Manager on appropriate action to correct negative trends and to reinforce positive performance.

- Assist the Construction Manager in preparing an Emergency Management Plan by coordinating the inputs of the interested and affected parties and ensure integration of the plan with Transnet Operating Divisions.
- Investigate to identify the root causes of all incidents and near misses and ensure continuous follow-up in order to immediately correct unsafe acts and conditions.
- Report on Health and Safety performance and statistical process controls as directed by the Project/Construction Manager and Health and Safety Agent.
- Monitor and ensure that all factors likely to improve health and safety are taken into consideration such as Job Specific Hazard Assessments by Contractors, Daily Safety Task Instruction (DSTI), Contractor Housekeeping, Training, Occupational Health and Hygiene, Safe Systems of Work and Safe Work Procedures.
- Promote accurate communication on all Health and Safety matters with regards to safety committee meetings, inspections and audits findings.
- Conducts Health and Safety walkabouts, Visible Field Leadership (VFL) with Contractors and Transnet Port Terminals Construction Supervisors and directs appropriate corrective actions.

Health and Safety Management on site will be controlled by the delegated persons ensuring compliance with the TPT Health and Safety Guideline and any specific requirements contained in the Works Information.

Also refer to TPT's SHEQ Policy for inclusion in the Works Information.

6.1.7 COVID 19 Compliance Officer

- The Contractor must appoint a Compliance Officer and are required to develop a company COVID-19 Workplace Plan, in a bid to facilitate the proper and effective application of the Occupational Health and Safety Act, the COVID-19 Direction on Health and Safety in the Workplace, issued by the Minister in terms of regulation 10(8) of the National Disaster Regulations and the regulations issued in terms of Section 27(2) of the Disaster Management Act.
- As a guideline, Transnet Ports Terminal Saldanha, have highlighted the minimum requirements that a contractor have to include in their Workplace Plan:

INDEX #	REQUIREMENT
1	COVID 19 Risk assessment and control plan

2	Social Distancing Measures
3	Hygiene Measures - disinfection / cleaning work place area(s); e.g. mess/ablution rooms, locker rooms, communal areas; etc.
4	Measures for Screening, Testing and Response to suspected and positive cases
5	Employee awareness, engagement and communication
6	Provision of Personal Protective Equipment (PPE) – Individual Cloth Mask
7	Provision of Personal Protective Equipment (PPE) – Other PPE and Hygiene Measures
8	Measures to control Public that may have access or is allowed to workplaces
9	Transportation arrangements of personnel
10	Waste Management of Disposable COVID-19 material, masks, gloves, etc.
11	Legal Reporting obligations (Employer and Employee)
12	Measures to Monitor and Enforce compliance

6.1.8 Contractor/Service Provider Professional Health and Safety Agent

An OHS Safety Agent has been appointed i.t.o. Construction Regulation 5 of OHS Act 85 of 1993 and CR (Construction Regulations) 2014.

The OHS Safety Agent is registered with SACPCMP as a Professional Health and Safety Agent.

The OHS Safety Agent will in the appointed capacity ensure that the following stipulations in terms of the Occupational Health and Safety Act, Act 85 of 1993 and specifically the CONSTRUCTION REGULATIONS 2014 be complied with, at all times within the area of jurisdiction:

- a. Prepare a documented Health and Safety Specification for the construction work and provide any principal contractor with the same (completed – refer to H&S Management Plan).
- b. Provide the principal contractor and his or her agent with any information which might affect the health and safety of any person at work carrying out construction work.
- c. Ensure that each principal contractor's health and safety plan is implemented and maintained on the construction site: Provided that the steps taken, shall include

periodic audits at intervals mutually agreed upon between the client and principal contractor, but at least once every month.

- d. Stop any contractor from executing construction work which is not in accordance with the principal contractor's health and safety plan contemplated in sub-regulation 5 (1)(q) for the site or which poses to be a threat to the health and safety of persons
- e. Ensure that where changes are brought about, sufficient health and safety information and appropriate resources are made available to the principal contractor to execute the work safely
- f. Ensure that every principal contractor is registered and in good standing with the compensation fund or with a licensed compensation insurer prior to work commencing on site
- g. Ensure that potential principal contractors submitting tenders, have made provision for the cost of health and safety measures during the construction process.
- h. The agent shall discuss and negotiate with the principal contractor the contents of the health and safety plan contemplated in sub regulation 5(1) and thereafter finally approve the health and safety plan for implementation.
- i. A client shall ensure that a copy of the principal contractor's health and safety plan is available on request to an employee, inspector or contractor
- j. No client shall appoint a principal contractor to perform construction work, unless the client is reasonably satisfied that the principal contractor that he or she intends to appoint has the necessary competencies and resources to carry out the work safely.

The scope of the OHS Safety Agent will be applicable to all activities of employees on the construction site.

6.1.9 Environmental Officer

The TPT Environmental Officer is responsible for conducting the tasks required to ensure that the CEMP and SES are implemented on the construction site.

The TPT Environmental Officer will conduct the following tasks:

- Ensure that environmental issues receive adequate attention in the site induction training.
- Prepare and conduct awareness training (e.g. posters, tool box talks, and signage).
- Conduct monthly observation & inspections and audit of all work places.
- Monitor the Contractor's compliance with the CEMP and SES on site.
- Conduct monthly observations and environmental audits of all Contractor's and work areas.
- Ensure that all environmental monitoring programmes (sampling, measuring, recording etc. when specified) are carried out according to protocols and schedules.

- Measurement of completed work (e.g. areas top soiled, re-vegetated, stabilised etc.).
- Maintain site documentation related to environmental management (permits, CEMP, method statements, reports, audits, monitoring results, receipts for waste removal etc.).
- Documentation to be maintained on the relevant site Document Control System.
- Attendance at scheduled SHE meetings and project coordination meetings.
- Inspect and report on environmental incidents and check corrective action.
- Keep a regular photographic record of all environmental incidents.
- Implementation of environmental-related actions arising out of the minutes from scheduled meetings.
- Management of complaints register.
- Review and Sign off Method Statements prepared by Contractor's.
- Audit Environmental Method Statements.
- Collate information received, including monitoring results into a monthly report to the Construction Manager showing progress against targets.
- The compilation of the Project Environmental Management File.

The key deliverables will include the compilation of:

- Project start-up Checklist;
- Monthly inspection/environmental audit report;
- Monitoring results;
- Site close-out reports;
- Incident reports;
- Environmental Incident Register;
- Environmental Non-Conformance Register;
- Complaints Register;
- Method Statements Register;
- Hazardous Substances Register;
- Site Close out Inspection.

6.1.10 Document Control

The Document Control Department is responsible for the quality checking of documentation, scanning, reproduction of documentation, preparing CD's, archiving, close-out and handover of documentation, as defined in the TPT Document Control Methodology.

The Document Control Department facilitates and controls the delivery of project document deliverables. These deliverables shall be determined and confirmed by the Document Controller and the Project Manager at project initiation. Document Controllers

shall report the progress on the delivery of documents deliverables throughout the lifecycle of the project.

All project correspondence of any nature and form shall be forwarded to Document Control for capturing and safekeeping. Project managers shall apply Transnet Information Classification Policy, Records Management Policy and their discretion to determine the criticality and value of project documents and thereafter advise and instruct Document Controllers whether to capture correspondence.

6.1.11 Industrial Relations Practitioner

The TPT/BTS Industrial Relations Practitioner shall support the TPT Project Manager and Construction Manager in overseeing the establishment of site wide policies appropriate to site conditions, and will participate in the committees established to co-ordinate among all the contractors in accordance with the requirement of the TPT IR Framework and Policy.

6.1.12 Principal Contractor and his Sub-Contractors

In addition to his responsibilities under the OHS Act, the Principal Contractor and his appointed Sub-Contractors are responsible for the following:

- Attending regular progress meetings as determined by the Project Manager;
- Attending regular technical meetings as determined by the Construction Manager;
- Monitoring and reporting of progress;
- Keeping and updating photographic records;
- Ensuring adequacy of resources;
- Complying with Transnet's Skills Development Programme;
- Abide to TPT safety and environmental policies and procedures ensuring the quality of completed work is in accordance with the specifications;
- Completing the works or parts thereof in accordance with the accepted programme;
- Supply as-built documents and testing and commissioning records in accordance with the contract and applicable legislation.

Before commencing the works, the Principal Contractor shall advise the Project Manager in writing of the name of their appointed Responsible Person(s) and their area(s) of responsibility.

6.1.13 All Personnel

Every person employed on the Project has a statutory duty to take reasonable care for the H&S of themselves and others as well as the environment that may be affected by their actions or omissions at work.

Regarding the statutory duties imposed on their employer, they must co-operate with their employer to enable him to comply with the relevant statutory provisions.

No person shall intentionally or recklessly interfere with or misuse anything provided for safety, health or welfare under the relevant statutory provisions.

All personnel shall:

- Wear or use the appropriate safety equipment and/or clothing and use the appropriate safety devices.
- Familiarize themselves with the relevant requirements of the Health and Safety Plan, the Environmental Plan and the appropriate requirements in any other related H&S document, plan, standard or guideline.
- Report any incidents and damage to property or equipment to their immediate supervisor, irrespective of whether persons are injured.
- Be encouraged to make suggestions to their respective supervisors and H&S Officers to improve H&S.
- Familiarise themselves with and adhere to the project golden rules and any other requirement the client or Consultant might prescribe.

7. Commissioning, Testing and Handover

Commissioning, testing and handover will be done in accordance with the approved Commissioning Plan (Z.5200160-CP), contained in the FEL 3 documentation.

SECURITY MANAGEMENT PLAN

SECURITY MANAGEMENT PLAN

For: Transnet Port Terminals (TPT), Saldanha
Project Name: FEL3 - Saldanha Bulk Terminal Equipment Refit:
Stacker Reclaimers, Ship Loaders and Tippler 2.
(Phase-4: Stacker Reclaimer 3)

Project Number: Z.5200160

Author: Marlene Nel
Owner: Louis du Toit (Terminal Manager)
Client: Transnet Port Terminals (TPT)
Project Sponsor: Andiswa Dlanga (Managing Executive)
Project Manager: Graham Handley

Revision Number: 00

Approved by: Ntsikelelo Nteta

Document No: Z.5200160-SMP

DOCUMENTATION DISTRIBUTION, REVISION AND APPROVAL HISTORY

REVISION NUMBER	DATE	DISTRIBUTION	PREPARED BY	REVIEWED BY	APPROVED BY
00	12/01/2021	1	M. Nel	G. Handley	N. Nteta

SIGNATORIES:

Prepared by:



M. Nel

18.01.2021

Marlene Nel
Terminal Security Manager

Date

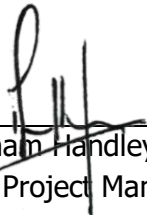
Reviewed by:



19/01/2021

Graham Handley
Snr. Project Manager

Date

Approved by:



19/01/21

Ntsikelelo Nteta
Regional Risk & Compliance Manager

Date

TABLE OF CONTENTS

SECTION 1	ADMINISTRATIVE DETAILS	4
1.1	AUTHORITY.....	4
SECTION 2	SCOPE.....	5
SECTION 3	PROJECT OVERVIEW.....	5
3.1	OPERATIONAL PLAN LAYOUT.....	6
3.2	PHYSICAL SECURITY LAYOUT.....	7
SECTION 4	CONSULTATION, COMMUNICATION AND COORDINATION.....	8
4.1	SECURITY PLAN MECHANISM FOR CONSULTATION.....	8
4.2	STAKEHOLDERS COMMUNICATION AND CONSULTATION	8
4.3	EMPLOYEES AND CONTRACTORS.....	8
SECTION 5	OPERATION OF THE PLAN.....	9
5.1	REVIEW AND AUDIT	9
5.2	RESPONSIBILITIES	9
5.3	KNOWLEDGE AND TRAINING.....	10
5.4	PROJECT SECURITY INDUCTION.....	10
SECTION 6	SECURITY MEASURES AND PROCEDURES	11
6.1	SECURITY THREAT AND RISK ASSESSMENT (TRA).....	11-12
6.2	SECURITY LEVEL 1	13
6.3	SECURITY LEVEL 2 & 3	13
SECTION 7	COMMUNICATIONS.....	15
SECTION 8	SECURITY PLAN REVIEW.....	15
ANNEXURE 1	BASELINE SECURITY RISK ASSESSMENT	
ANNEXURE 2	STANDARD OPERATING PROCEDURES: SECURITY COMPANY, CONTRACTOR & TPT	
ANNEXURE 3	SAP 16 PROCESS FLOW	
ANNEXURE 4	MINIMUM PHYSICAL SECURITY STANDARDS	
ANNEXURE 5	PORT RULES	
ANNEXURE 6	SECURITY STATISTICS	
ANNEXURE 7	PORT ACCESS CONTROL STANDARD OPERATING PROCEDURE	
ANNEXURE 8	PROCEDURE FOR FILMING AND PHOTOGRAPHY CONTROL	

Section 1 Administrative details

1.1 Authority

This Security Plan was compiled by Graham Handley, and was reviewed by Security Manager, Marlene Nel. The Security Department supports the implementation of the plan. The plan is submitted for approval by the relevant Program members.

Section 2

Scope

Refer to Annexure 1 – Baseline Security Risk Assessment, which was conducted and serves as input to this document.

The scope of this security management plan is to identify and prioritise the various security risks involved with a project of this magnitude. Secondly a cost-effective solution must be agreed upon by all Project members involved. This document to be read with all attachments.

Project Managers may wish to expand the coverage of their plan to include related operations and activities.

All aspects of security are covered in the plan. These include but are not limited to:

Security administration

Physical security

Mobile security

Personnel security

Asset security

Standard operating procedures, rules and requirements are listed in Annexures 2, 4, 5, 7 and 8, and should be read in conjunction with this document.

Section 3

Project Overview

Project Manager	Graham Handley	
Construction Manager	To be appointed	
Safety Practitioner	Rejean Viljoen	
Security Manager	Marlene Nel	

3.1 Operational Plan Layout



3.2 Physical Security Layout

Post	No. and Grade of officer	Day Shift	Night Shift	Post specific Equipment
Access Control	Grade C			Shelter Portable Toilet Handheld radio PPE Torch Occurrence Book Access control register Breathalyser
Supervisor	Grade B			Shelter Portable Toilet Handheld radio PPE Torch Occurrence Book Access control register Breathalyser

Section 4 Consultation, Communication and Coordination

4.1 Security plan mechanism for consultation:

- a) Between the Project Team and members of the TPT Security Department.
- b) Between TPT Security Department, local SAPS and TNPA security.
- c) Between TPT Security Department and its personnel and contractors regarding security measures and procedures to be implemented.

4.2 Stakeholders communication and consultation:

A monthly steerco Meeting will be held with stakeholders from TNPA, TPT, BTS, Mines etc, as well as senior management representatives of the project. Security will be discussed at these meetings as well as at the weekly project meetings. For further information regarding identified stakeholders refer to stakeholders listed in the Project Execution Plan, Z.5200160-PEP.

4.3 Employees and contractors:

Employees and sub-contractors will need to assist with the implementation of security measures and procedures on site, as well as reporting of any incidents per flash report to Security timeously.

Section 5 Operation of the Plan

5.1 Review and audit

- TPT Security will ensure that the plan is effective and adequate and that the plan has been implemented correctly by means of a monthly site audit by TPT in house security staff when applicable.
- This will include a consultation with employees and project managers to ensure security measures and procedures are adequate and the plan is appropriately implemented.
- It is suggested that for ease of maintaining audit and review procedures that they should be referenced in this section and specific details included as attachments.
- Penalties can be implemented as per Transnet's Master Service Level Agreement, Low to High risk area.

5.2 Responsibilities

The Project Security Plan must detail the specific duties and responsibilities of the Security Manager and other security personnel (for example the duties and responsibilities of any security officers employed or contracted to TPT for the projects).

Position	Responsibilities
Security Manager	Conduct audits per project site Liaise with security companies Report on findings to project managers
Senior Investigator	Investigate any incidents and review site instructions Assist with site audits Implement changes needed to site security
Outsource Contract Security Officers	Patrol of site premises and access control Record all incidents/ irregularities in site occurrence book Report to control room and TPT & TNPA Security.
Security Control Room Operators	Manage daily site postings Report any irregularities to TPT Security Manager Be in constant contact with sites under their control

5.3 Knowledge and training

Transnet must ensure that security guards with responsibility for security have adequate knowledge and have received appropriate training to be able to carry out their duties. If findings find a lack of knowledge regarding executing his/her security function refresher training must be immediately implemented. This includes site security specific, safety training, referred to as site induction. On the job training should be done by service provider.

PSIRA will also be confirmed per security guard and companies will be required to always wear appropriate PPE on all project sites. Any guard found/seen on site without the correct PPE will be removed and replaced at the contractor/security companies own cost.

Security File per site must be provided and include:

- List of training or qualifications per guard:
- PSIRA certificate. (SAPS certified)
- CV and course certificates
- Identity Documents (SAPS certified)
- All relevant site induction material pertaining to specific site
- First Aid
- Fire Fighting
- Standard Operating Procedures site specific.
- Company Security Officers site instruction and work procedures
- Company site contingency plan/strike plan.
- Security disciplinary code for security officers.
- Detailed contact list in case of emergency displayed

Monthly security performance review will be conducted on file.

5.4 Project Security Induction:

Project security supervisor name, security office and contact details

Security Policy

Crime trends and hotspots (refer to annexure 6 for Security Statistics)

Project weapons, cameras, drug and alcohol policy (refer to annexure 8 for procedure for photography control)

Access badge and Identification

Response to facility security incidents

Classification of suspicious activity and how to report it

Section 6 Security Measure and Procedures

6.1 Security measures and procedures.

All measures and procedures per site will be attached at the end of the document and labelled accordingly, referred to as Standard Operating Procedures (SOP). Refer to the following annexures: Annexures 2, 4, 5, 7 and 8.

a) Measures to prevent unauthorised carriage or possession of weapons or prohibited items on the site;

If appropriate, these measures could include but are not limited to:

- The screening and clearing of staff and visitors when accessing the site.
- Following of Transnet fire-arm policy and Access Control policy (Annexure 7 – Port Access Control Standard Operating Procedure).

b) Measures to prevent unauthorised access to the site ;

If appropriate, these measures could include but are not limited to:

- Perimeter fencing around the site boundaries covered by the plan;
- Procedures for the clearing of people that wish to enter the project site;
- Regular security patrols;
- List of authorised project staff for access control measures.

c) Procedures for responding to security threats or breaches, including provisions for maintaining critical operations on the site;

If appropriate, these procedures could include but are not limited to:

- Procedures for armed response to respond to level 1 situation.
- Procedures for the contacting of National Command Centre as well as Group Security if threat warrants it. Level 2 and above

d) Procedures for responding to and implementing any new security standards or legislation issued or initiated by Transnet Group;

If appropriate, these procedures could include but are not limited to:

- Management procedures that will be taken to ensure that a new security standard or legislation is implemented as soon as possible after being issued.
- Procedures for communicating the new procedures within Transnet and externally where necessary.

e) Procedures for evacuation of the site in case of security/safety threats;

This should include reference to a current contingency/evacuation plan.

f) Procedures for reporting occurrences (e.g. security breaches) which threaten the security of the site;

These procedures should include, but are not limited to, procedures for reporting occurrences to:

- National Command Centre;
- the SAPS;
- Internal procedures (flash reports) for employees to report security breaches/incidents to management or the Security Manager.
- Procedures for raising the awareness of staff of their responsibilities for reporting incidents.

g) Measures to ensure the security of physical assets of Transnet at the site;

The security plan will include measures to protect the physical assets of the institution at facilities of the institution.

If appropriate, these procedures could include but are not limited to:

- Requirements for admission/receiving of material or supplies.(TNPA port entrance to declare all equipment entering the port)
- Controls for movement of assets on the premises from one area to another. (Material registers/Material despatch register)
- Permission slips (three fold) for removing assets of Transnet from the site.
- Material Movement - SAP 16 Process Flow. (Annexure 3)

6.2 Security Level 1

These measures must include:

- The security measures identified in the security TRA for the institution, for implementation at Security Level 1.

This table can be used to record the security measures.

SECURITY MEASURES AND PROCEDURES AT SECURITY LEVEL 1

Description of security measure or procedure.	Person with responsibility for implementing the measure or procedure
Perimeter Fencing, staff security clearances, security guard patrols etc.	Security Manager, Security Officials Employees, etc.

6.3 Security Levels 2 and 3

The following tables can be used to record the security measures and procedures.

SECURITY MEASURES AND PROCEDURES AT SECURITY LEVEL 2

Description of security measure or procedure.	Person or Organisation with responsibility for implementing the measure or procedure
Increased number of security guard patrols, limit access to site for non-essential personnel.	Security Manager, Security Officials, Employees, etc.

Note. Security Level 2 measures or procedures are in addition to all of the measures and procedures in force at security level 1.

SECURITY MEASURES AND PROCEDURES AT SECURITY LEVEL 3

Description of security measure or procedure.	Person or Organisation with Responsibility for implementing the measure or procedure
Evacuation of site where threat has been identified.	Security Manager, Security Officials, Employees, etc.

Note. Security Level 3 measures or procedures are in addition to all of the measures and procedures in force at security levels 1 and 2.

IMPLEMENTATION TIMETABLE

Security Measure or Procedures	Status (Operational / To be established)	Date of expected implementation (if status is to be established)	Interim measures / procedures
Perimeter security fencing.	To be established	Fencing to be in place by completion of site establishment	Temporary barriers and signs installed to identify the construction area. Additional guard patrols to monitor and deter any

			unauthorised access.
Flash report	Reporting line followed	Directly after incident has taken place.	Notify security of the incident and complete the incident Flash report documentation.

Section 7

Communication

Communication is vital for the routine day to day administration of the function, as well as ensuring that all vested parties are notified of security matters in a timeously manner, facilitating the initiation and implementation of an appropriate response, to events that could impact the security and safety of personnel.

A single point for reporting of security related information will be maintained by the security manager or appointed representative. The security representative is responsible for the verification of all information.

Relevant security information is to be cleared by program manager for release and distributed as soon as possible via email or mobile phone messaging.

Security Communication can be classified as follows:

- Routine security communications
- Security flash notifications
- Security Incident reporting

Section 8

Security plan and review

This plan needs to be reviewed in response to any security incident that highlights deficiencies that's needs to be address.

- Annexure 1: Baseline Security Risk Assessment
- Annexure 2: Standard Operating Procedures: Security Company, Contractor & TPT
- Annexure 3: SAP 16 Process flow
- Annexure 4: Minimum Physical Security Standards
- Annexure 5: Port Rules
- Annexure 6: Security Statistics
- Annexure 7: Port Access Control Standard Operating Procedure
- Annexure 8: Procedure for filming and photography control



COMMUNICATION MANAGEMENT REPORT

COMMUNICATION MANANAGEMENT REPORT

For: Transnet Port Terminals (TPT), Saldanha

Project Name: FEL3 - Saldanha Bulk Terminal Equipment Refit: Stacker Reclaimers, Ship Loaders and Tippler 2. (Phase-4: Stacker Reclaimer 3)

Project Number: Z.5200160

Author: Graham Handley
Owner: Louis du Toit (Terminal Manager)
Client: Transnet Port Terminals (TPT)
Project Sponsor: Andiswa Dlanga (Managing Executive)
Project Manager: Graham Handley

Revision Number: 00
Approved by: Lipuo Lebakeng

Document No: Z.5200160-CMR

DOCUMENTATION DISTRIBUTION, REVISION AND APPROVAL HISTORY

REVISION NUMBER	DATE	DISTRIBUTION	PREPARED BY	REVIEWED BY	APPROVED BY
00	23/11/2020	1	G. Handley	M. Mazubane	L. Lebakeng

SIGNATORIES:

Prepared by: 

Graham Handley
Snr. Project Manager

23/11/2021

Date

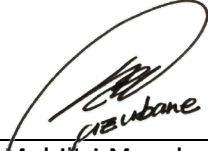
Reviewed by: 

Mphisi Mazubane
Snr. Manager

23/11/2021

Date

Approved by: 

Lipuo Lebakeng
Corporate Affairs Manager

03/03/2021

Date

1. Introduction

This document describes the Communication Management Plan for the BTS Equipment Refit project FEL4.

2. Objective

To enable effective, constant communication between all stakeholders on the project. Specific goals shall be to:

- Provide a structured mechanism to convey to all stakeholders the appropriate project related information to ensure that they are kept informed of progress and issues related to project delivery.
- Provide to TPT senior management/ Client/ Steering Committee the necessary project related information to assess the project's status.
- Provide all project related information on a regular basis to TPT senior management and Client indicating the status, risks, financial information and all other project issues raised during the reporting period.
- Provide a mechanism for seeking and acting on feedback from stakeholders, and encourage stakeholder involvement.
- Ensure that correct information is transmitted to the relevant people at the right time.



3. Project Specific Communication Plan

Project Management Meetings		
Meeting	Frequency	Convenor
Project Steerco	Monthly	Senior Manager TPT Capital Execution
Project Risk Workshop	Every 4 Months	Project Manager/Risk Manager
Project Progress Meeting (Incl. Risk Review)	Monthly	Project Manager

Site Meetings during execution		
Meeting	Frequency	Attendance by:
Site/Contractor kick off meeting	Once. At site establishment	Construction Management Team, Project Management team, Contractors management team
Execution progress meeting	Daily during execution	Construction Management Team, Project Management team, Contractors management team
Weekly SHE meetings	Weekly during execution phase	Construction Management Team, Contractors management team
SHE Mobilisation Meeting	1 week prior to site establishment	Construction Management Team, Project Management team, Contractors management team

4. Critical Stakeholders

Division/Role	Name	Contact
TPT		
GM Capital Projects and Operations Technology	Sathish Ganesh	083 388 7456
Senior Manager Capital Projects	Mphilisi Mazubane	021 449 6449
Senior Project Manager	Graham Handley	021 449 4381
Project Manager	Singatha Limba	072 859 8590
Terminal Manager	Greg Abrahams	083 285 3524
Project Sponsor	Andiswa Dlanga	083 368 9779
Chief Engineer	Carols Engelsman	073 191 9990
Engineering Manager: Plant	Ebrahim Jacobs	022 703 4420
Engineering Manager: Technical Services	Kallie Niemand	022 703 4998
SHERQ Manager	Rejean Viljeon	022 703 4939
Chief Operations Manager MPT	Eben Kannemeyer	022 703 4621
Chief Operations Manager BTS	Nonkoliseko Didi	022 703 4933
Risk & Compliance	Ntsikelelo Nteta	021 449 2174
Project Planner	Sibusiso Khumalo	073 124 1447
Procurement Local	Nazley Hardy	021 449 3146
Procurement HQ	Rory Torr	031 3088 130
Security Manager	Marlene Nel	022 703 4953
Communications	Lipuo Lebakeng	0738000497
Key Accounts Manager	Christopher Gomez	022 703 4204
TNPA		
Port Manager	Vernal Jones	022 703 5472
TFR		
Executive Manager - Operations	Keitheng Adeolu	021 940 3409
General Manager – Cape Channel	Russell Baatjies	021 940 3415
SFF – OIL TERMINAL		
Operations Manager	David Strauss	022 703 6200
CONTRACTORS		
FEL3 Execution Consultant – World Crane Services	Samual Bema	
FEL 4 –Execution Consultant	TBA	
Stacker Reclaimer 3	TBA	
MINES		
Kumba Iron Ore	Aart van den Brink	
Assmang	Rilette Avenant-Buys	
Sedibeng Iron Ore	Bushan Banotha	
Afrimat	Michael Corbin	
Autumn Skies	Lionel Koster	

5. Correspondance

Project team members may only communicate project related issues internally with direct line managers or to team members.

Correspondence, of a contractual nature, shall be via hard copies, with original signature, but may be copied via email to the recipients. Day to day correspondence shall be via email. All correspondence will be filed at the TPT project office in accordance with the requirements of the TPT Document Control Procedure.

6. Work and Lock-out Permits

As per Bulk Terminal Saldanha standard operating procedures.

TPT will ensure compliance with the requirements of the Air Emissions License (AEL). All communication in this regard will be conducted through the TPT SHEQ Manager.

7. Progress Reporting

Daily progress reporting, during project execution, shall be communicated to the TPT SPM, by means of daily dashboard reports.

Progress reporting will be undertaken on a monthly basis, with a Monthly Progress Report t These progress reports, via minutes/action register, will be co-ordinated by the TPT Senior Project Manager.

The TPT Senior Project Manager will report to the monthly Steerco.
The TPT Senior Manager will report to CAPIC

8. E-mail Communications

E-mail communications will be allowed and regarded as official project communication. E-mails are a fast and effective means of communicating in real time, e-mails will be followed up with formal contractual communication/s. All Formal/Contractual correspondence to be transmitted through Document Control.

9. Instructions to Contractors

Instruction/s to the Contractor will be via NEC3 and communicated through the Project Manager's Instruction (PMI) by the Senior Project Manager

10. Safety, Environment, Quality

Safety, environment and quality incident reporting shall be as per TPT's standard discipline reporting templates and policies. Refer to Health & Safety Management Plan.

11. Instructions to Medical Staff

Only the Senior Project Manager/ Supervisor may give direct instructions to the emergency response medical staff on site besides the Contractor's legal appointees.

12. Communication with Stakeholders

All external communication with stakeholders will be managed by TPT.

13. Communication Channels

During the FEL 4 stage, e-mails and NEC templates will be used to communicate with the Contractor.

Contractor Environmental and Sustainability Specification Guidelines

TABLE OF CONTENTS

1	Purpose.....	2
2	Scope.....	2
3	Abbreviations and Definitions.....	2
	3.1 Abbreviations	2
	3.2. Definitions	3
4	Minimum Standards for Environmental Management	6
	1.1. Site Planning and Establishment	6
	1.1.1. Site plan	6
	1.1.2. Identification and establishment of suitable access routes/roads ..	7
	1.1.3. Demarcation of site limits	7
	1.1.4. Eating Areas	8
	1.1.5. Liquid waste Management	8
	1.2. Sewage and Sanitation	8
	1.3. Waste Management	9
	1.4. Workshops, equipment maintenance and storage	13
	1.5. Vehicle and Equipment Refueling	14
	1.5.1. Stationary/Designated Refueling	14
	1.5.2. Mobile Refueling	14
	1.6. Spill Response	15
	1.7. Spray Painting and Sandblasting	17
	1.8. Dust Management	17
	1.9. Storm water and Dewatering Management	19
	1.10. Erosion Control	20
	1.11. Noise Management	21
	1.12. Protection of heritage resources	22
	1.12.1. Archaeological Sites	22
	1.12.2. Graves and middens	22
	1.13. Fire prevention	22
	1.14. Water Protection and Management	23
	1.15. Protection of Fauna and the collection of firewood	23
	1.16. Environmental Awareness Training	24
	1.17. Handling and Batching of Concrete and Cement	25
	1.18. Stockpiling, Soil Management and Protection of Flora	26
	1.19. Traffic Management	27
	1.20. Transportation of Materials	28
	1.21. Borrow Pits and Quarries	28
	1.22. Social and Labour Issues	28
	1.23. Energy Management	29
	1.24. Handling, Storage and Management of Hazardous Substances	29
	1.25. Housekeeping	30
	1.26. Rehabilitation	31
5	Documentation.....	31
6	Records.....	32

1 Purpose

This specification describes the minimum standards for environmental management to which Contractors and Sub-contractors on a construction site must comply. It is a generic standard for use across all works within Transnet.

There may be project specific environmental standards in addition to the standards in this document that exceed the standards prescribed here. The project specific environmental standards will be described in the Project Environmental Specification (PES) that will be issued separately for each project (where relevant).

This document must be read in conjunction with the Transnet Construction Environmental Management Plan (CEMP).

2 Scope

This standard applies to Contractors that work on site under the authority of Transnet.

3 Abbreviations and Definitions

3.1 Abbreviations

CEMP	Construction Environmental Management Plan
DEA	Department of Environmental Affairs
EA	Environmental Authorization
EO	Environmental Officer
EGF	Environmental Governance Framework
NEMA	National Environmental Management Act 107 of 1998 (as amended)
NEM:BA	National Environmental Management: Biodiversity Act 10 of 2004

NWA	National Water Act 36 of 1998
PES	Project Environmental Specification
SES	Standard Environmental Specification
SHEQ	Safety, Health, Environment and Quality
CM	Contract Manager
PEM	Project Environmental Manager

3.2. Definitions

Fauna A group of animals specific to a certain region or time period.

Flora A group of plants specific to a certain region or time period.

General waste Waste that does not pose an immediate hazard or threat to health or to the environment; and includes:-

- (a) domestic waste;
- (b) building and demolition waste;
- (c) business waste;
- (d) inert waste; or
- (e) any waste classified as non-hazardous waste in terms of NEMWA, 59 of 2008.

Hazardous waste Any waste that contains organic or inorganic elements or compounds that may, owing to the inherent physical, chemical or toxicological characteristics of that waste, have a detrimental impact on health and the environment and includes hazardous substances, materials or objects within business waste, residue deposits and residue stockpiles.

Indigenous vegetation Plants that naturally occur in an area.



Liquid waste	Waste that appear in liquid form such as used oil, grease and/or contaminated water or waste water.
Method statement	A document that describes how the Contractor will apply environmental management measures associated with a particular environmental aspect during construction. It is a written submission by the Contractor to the Transnet EO or CM in response to this Specification or a request by the Engineer, an ECO or Authorities setting out the equipment, plant, materials, labour and method the Contractor proposes to use to carry out an activity identified by this Specification or the Transnet EO when requesting the Method Statement, in such detail that the Transnet EO is able to assess whether the Contractor's proposal is in accordance with this Specification and/ or will produce results in accordance with this Specification.
Natural Vegetation	All existing species, indigenous or otherwise, of trees, shrubs, groundcover, grasses and all other plants found growing on the site.
Responsible Authority	A Responsible Authority, according to the National Water Act 36 of 1998, relates to specific power or authority in respect of water uses that is assigned by the Minister to a Catchment Management Agency or to a Regional Office.
Sensitive area	Any area that is denoted as sensitive by this Specification due to its particular attributes, which could include the presence of rare or endangered vegetation, the presence of heritage resources (<i>e.g.</i> archaeological artefact or graves), the presence of a unique natural feature, the presence of a watercourse or water body, the presence of steep slopes.
Solid waste	All solid waste, including construction debris, chemical waste, excess cement/ concrete, wrapping materials, timber, tins and cans, drums, wire, nails, food and domestic waste (<i>e.g.</i> plastic packets and wrappers).

Spoil	Excavated material which is unsuitable for re-use as material in the Works or any other use; or is material which is surplus to the requirements of the Works.
Temporary Storage	A once-off storage of waste for a period not exceeding 90 days.
Topsoil	Means a varying depth (up to 300 mm) of the soil profile irrespective of the fertility appearance, structure, agricultural potential, fertility and composition of the soil.
Waste	Any substance, material or object, that is unwanted, rejected, abandoned, discarded or disposed of, or that is intended or required to be discarded or disposed of, by the holder of that substance, material or object, whether or not such substance, material or object can be re-used, recycled or recovered and includes all wastes. Waste or a portion of waste ceases to be a waste only once the waste is, or has been re-used, recycled or recovered.
Watercourse	Means - a) a river or spring; b) a natural channel in which water flows regularly or intermittently; c) a wetland, lake or dam into which, or from which, water flows; and d) any collection of water gazetted by the National Water Act, 36 of 1998 as a watercourse, and a reference to a watercourse includes, where relevant, its bed and banks
Wetland	Land which is transitional between terrestrial and aquatic systems where the water table is usually at or near the surface, or the land is periodically covered with shallow water, and which land in normal circumstances supports or would support vegetation typically adapted to life in saturated soil.

Rehabilitation

Refers measures that must be put in place to restore the site to its pre-construction or enhanced state, subsequent to construction taking place.

4 Minimum Standards for Environmental Management

The Contractor shall identify the potential environmental aspects and impacts that may occur as a result of his/her activities and accordingly prepare separate Method Statements describing how each of these impacts will be prevented or managed so that the standards set out in this document are achieved. These method statements will be prepared in accordance with the requirements set out in the CEMP.

The Contractor will comply with the standards described below.

1.1. Site Planning and Establishment

The Contractor shall establish his construction camps, offices, workshops, eating areas and any other facilities on the site in a manner that does not adversely affect the environment. These facilities must not be sited in close proximity to sensitive areas; the buffer to be determined by the ecological requirements of the fauna/flora found on-site.

The Contractor shall ensure that a most recent, signed and dated Transnet IMS Policy is displayed on the notice-board at all times.

1.1.1. *Site plan*

Before the onset of construction, the Contractor shall submit to the Transnet CM and Transnet EO for his/her approval, plans of the exact location, extent and construction details of the proposed facilities and the impact mitigation measures the Contractor proposes to put in place. Any changes to the location of the facilities and site activities as per the approved site layout plan shall be re-submitted to the Transnet CM and Transnet EO for approval.

The Site Plan must as a minimum include but not necessarily be limited to:

- Detailed layout of the construction works areas including access roads, site offices, material laydown areas, temporary stockpile areas and parking areas;
- Detailed locality and layout of all waste storage and handling facilities for litter, kitchen refuse and workshop-derived effluent;
- Proposed areas for the stockpiling of topsoil and excavated spoil material;
- Demarcation of the construction footprint including areas not to be disturbed by the development;
- Location of sewage and sanitary facilities at the site offices and staff accommodation and at all localities on the site where there will be a concentration of labour. Sanitary arrangements should be to the satisfaction of the Transnet CM and Transnet EO on projects that have gone through the environmental impact assessment (EIA) process.

The site offices should not be sited in close proximity to steep areas. It is recommended that the offices, and in particular the ablution facilities, aggregate stockpiles, spoil areas and hazardous material stockpiles be located as far away as possible from any watercourse. Should this not be possible, approval for the location of these facilities must be granted by the Transnet EO.

1.1.2. Identification and establishment of suitable access routes/roads

Existing access routes to the construction/works areas must be used as far as possible. The building of access roads must be restricted to within the development footprint to prevent unnecessary disturbance of the surrounding environment. However, prior to making a decision about new access road, the Transnet EO must assess the proposed access road against the prevailing environmental legislation to confirm/rule out possible EIA triggers. Access tracks must be maintained in a good condition at all times during construction to minimize erosion and dust generation.

1.1.3. Demarcation of site limits

Prior to the commencement of construction, the actual site to be developed must be clearly demarcated by means of highly visible barriers such as fences and orange snow netting. Vegetation within the demarcated zone may be cleared only upon obtaining approval from the Transnet EO. Disturbance of vegetation outside of the demarcated development footprint is not permitted.

All plant, material and equipment required for construction must be located within the designated areas. Laydown areas must be clearly demarcated within the site limits. No activities are allowed outside of the demarcated development footprint.

1.1.4. *Eating Areas*

The Contractor is responsible for providing adequate eating facilities within the works area to ensure that workers do not leave the site to eat during working hours. Refuse bags/bins must be provided at all established eating areas and when full it should be disposed as required by Section 4.3.

1.1.5. *Liquid waste Management*

Liquid waste water from site shall be stored on-site in a properly designed and constructed system, situated so as not to adversely affect water courses (streams, rivers, pans, dams etc.). Only domestic type wastewater, i.e. toilet, shower, basin, kitchen water shall be allowed to enter the designated system.

1.2. Sewage and Sanitation

The Contractor is responsible for providing adequate sanitary facilities including toilets, toilet paper, wash basins etc. to all workers on site and for enforcing the proper use of these facilities. Safe and effective sewage treatment will require one of the following sewage handling methods: dry-composting toilets such as "enviro loos" or the use of chemical toilets which are supplied and maintained by a suitably qualified Sub-contractor. The type of sewage treatment will depend on the location of the site and the surrounding land uses, the duration of the contract and proximity (availability) of providers of chemical toilets.

Toilet facilities shall be serviced regularly and the waste material generated from these facilities shall be disposed of at a registered waste water treatment works/macerator and proof of servicing and disposal shall be made available in the Contractor EO's File.

Toilets and latrines shall be easily accessible and shall be positioned within walking distance from wherever employees are employed on the works. Use of open areas (i.e. the veldt) shall not, under any circumstances, be allowed. For projects of high mobility a mobile toilet facility shall be made available by the Contractor.

Outside toilets shall be provided with locks and doors and shall be secured to prevent them from blowing over. Toilets must not be placed in areas susceptible to flooding and high winds. The Contractor shall arrange for regular emptying of toilets and shall be entirely responsible for enforcing their use and for maintaining such facilities in a clean, orderly and hygienic condition to the satisfaction of the Transnet CM.

1.3. Waste Management

Waste is grouped into "general" or "hazardous", depending on its characteristics. The classification determines handling methods and the ultimate disposal of material.

General waste to be expected during construction includes the following:

- Trash (waste paper, plastics, cardboard, etc.) and food waste from offices, warehouses and construction personnel;
- Uncontaminated construction debris such as used wood and scrap metal; and
- Uncontaminated soil and non-hazardous rubble from excavation or demolition.

The Contractor shall classify all waste expected to be generated during the construction period. Examples of typical construction waste which could be expected on the site and how they should be classified are indicated in the following table:

TABLE 1: EXAMPLE OF CONSTRUCTION WASTE CLASSIFICATION

WASTE	CLASSIFICATION	
	HAZARDOUS	GENERAL
Aerosol containers	X	
Batteries, light bulbs, circuit boards, etc.	X	X
Clean soil		X
Construction debris contaminated by oil or organic compounds	X	
Domestic waste		X
Empty drums (depends on prior use)	X	X
Empty paint and coating containers		X
Explosive waste	X	
PCB waste	X	
Rubble (not contaminated by oil or organic compounds)		X
Waste Cable		X
Waste plastic		X
Waste paint and/or solvent	X	
Waste oil	X	
Waste concrete		X
Waste cement powder	x	
Waste empty cement bags (must be thoroughly decanted)		x
Waste containing fibrous asbestos	X	
Waste timber		X
Sewerage sludge	X	
Scrap metal		X
Chemically-derived sanitary waste	X	

A hierarchical control approach to waste management is encouraged. Waste should preferably be managed in the following order of preference:-

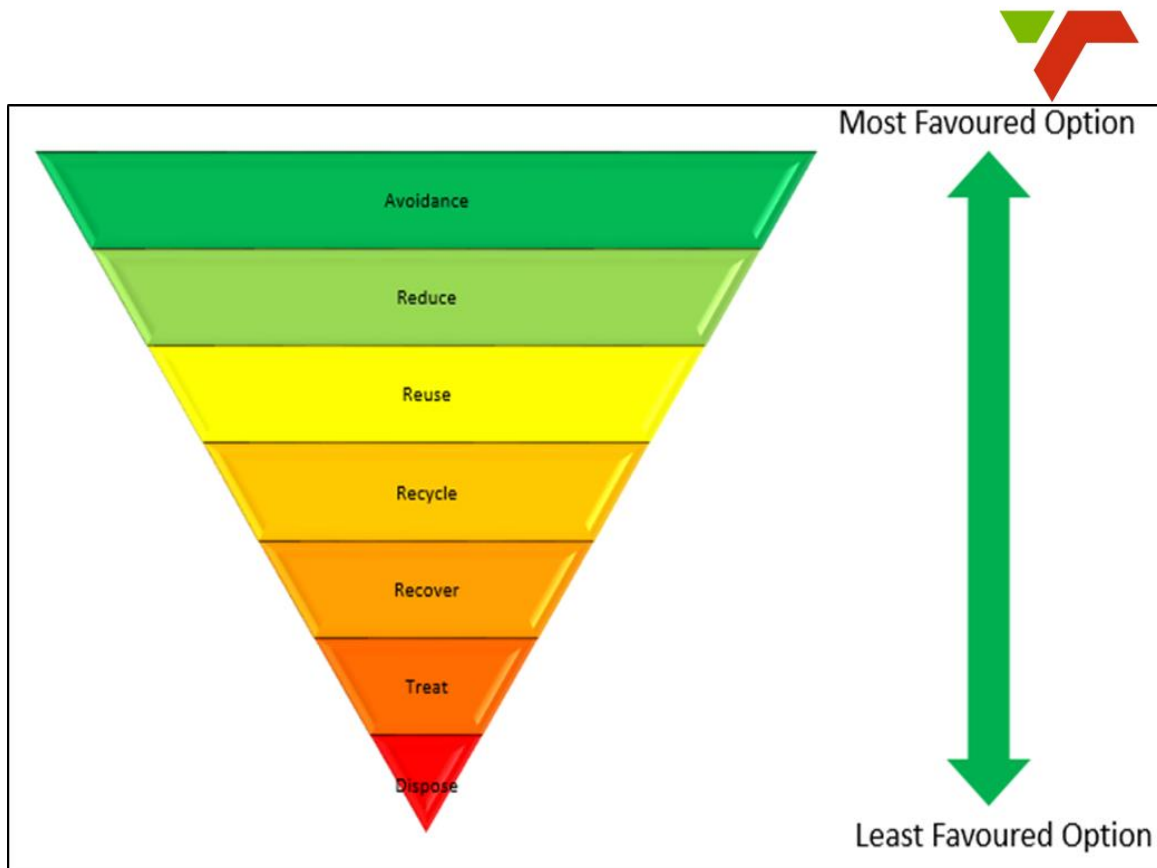

FIGURE 1: THE WASTE MANAGEMENT HIERARCHY

(Transnet Environmental Risk Management strategy and Framework, 2015:42)

- | | |
|-----------------------------------|---|
| 1. Avoidance/Prevention: | using goods in a manner that minimises their waste components |
| 2. Reduction/Minimisation: | reduction of the quantity and toxicity of waste generated during construction |
| 3. Re-use: | removing an article from a waste stream for use in a similar or different purpose without changing its form or properties |
| 4. Recycling: | separating articles from a waste stream and processing them as products or raw materials |
| 5. Recovery: | reclaiming particular components or materials, or using the waste as a fuel |
| 6. Treatment: | processing of waste by changing its form or properties in order to reduce toxicity and quantity |
| 7. Disposal: | burial, deposit, discharge, abandoning or release of waste |

The Contractor is responsible for the removal of all waste from site generated through the construction activities. The Contractor shall ensure that all waste is removed to appropriate licensed waste management facilities. (For the identification of an appropriate facility, the following source may be utilized: <http://sawic.environment.gov.za/>).

The Contractor's EO will work in conjunction with the Contractor's Safety and Health personnel to create a Hazardous Materials Management Program. This program will establish the necessary protocol for proper handling and removal of hazardous materials on the site.

The Contractor shall manage **GENERAL WASTE** that is anticipated to be generated by operations as follows:

- Notify waste hauler when container is full so that it can be removed and replaced with an empty container/skip;
- No littering is allowed on site. In the event where staff mobility is high, refuse bags will be made available by the Contractor;
- Provide documented evidence of proper disposal of waste (Waste Disposal Certificate)

The Contractor shall recycle **GENERAL WASTE** (as far as practically possible) that is anticipated to be generated by its operations as follows:

- Obtain and label recycling containers for the following (whichever relevant) and locate them within temporary office building and trailers:
 - Office Waste;
 - Aluminium;
 - Steel;
 - Glass;
 - Ferrous Metals;
 - Non Ferrous Metals; and

- Waste Timber
- Establish recycled material collection schedule
- Arrange for full bins to be hauled away

- Spent batteries, circuit boards, and bulbs, while non-hazardous, require separate storage, special collection and handling.
- No burning, burying or dumping of waste of any kind will be permitted.

The Contractor shall manage **HAZARDOUS WASTE** anticipated to be generated by his operations as follows:

- Obtain and provide an acceptable container with correct and visible classification label;
- Place hazardous waste material in allocated container;
- Inspect the container on a regular basis as prescribed by the Contractor's waste management plan;
- Track the accumulation time for the waste, haul the full container to the registered hazardous disposal site;
- Notify the waste hauler when container is full so that it can be removed and replaced with an empty container/skip; and
- Provide documented evidence of proper waste disposal of the waste (Waste Disposal Certificate).

The Contractor shall quantify all waste disposed of, whether general or hazardous (including waste disposed of by any sub-contractors) and keep record of these quantities on site.

1.4. Workshops, equipment maintenance and storage

All vehicles and equipment must be kept in good working order to maximise efficiency and minimise pollution. Maintenance, including washing and refueling of plant on site must be

done at designated locations at workshop areas. These designated areas must be agreed with the Transnet CM and Transnet EO. The Contractor must ensure that no contamination of soil or vegetation occurs around workshops and plant maintenance facilities. All machinery servicing areas must be bunded. Drip trays should be used to collect used oil, lubricants at all times. Drip trays must be provided for all stationary plant. Washing of equipment should be restricted to urgent maintenance requirements only. Adequate wastewater collection facilities must be provided and the wastewater should be disposed of at a registered hazardous waste disposal site.

1.5. Vehicle and Equipment Refueling

1.5.1. Stationary/Designated Refueling

No vehicles or machines shall be serviced or refuelled on site except at designated and approved servicing or refuelling locations. No oil or lubricant changes shall be made except at designate locations, or in case of breakdown or emergency repair.

The Contractor shall store fuel and oil at a secure area, which shall be bunded to contain 110% of the total volume within the bund and designed with an impervious layer or liner or paved surface to prevent spillage from entering the ground.

The Contractor shall provide details of its proposed fuel storage and fuelling facility to the Transnet EO for approval. The design shall comply with the regulations of the National Water Act, (Act 36 of 1998), the Hazardous Substances Act, (Act 15 of 1973), the Environmental Conservation Act, (Act 73 of 1989), National Environmental Management Act, (Act 107 of 1998), and the Occupational Health and Safety Act, (Act 85 of 1993), mainly the Construction - and Hazardous Chemical Substances Regulations.

1.5.2. Mobile Refueling

In certain circumstances, the refuelling of vehicles or equipment in a designated area is not a viable/practicable option and refuelling has to be done from a tank, truck, bowser or

container moved around on site. In such circumstances, the Contractor may request approval from the Transnet CM to conduct mobile refuelling subject to the following control measures:

- Secondary containment equipment shall be in place. This equipment shall be sized to contain the most likely volume of fuel that could be spilt during transfer.
- Absorbent pads or drip trays are to be placed around the fuel inlet prior to dispensing.
- Mobile refuelling units are to be operated by a designated competent person.
- The transfer of fuel must be stopped prior to overflowing. Fuel tanks or refuelling equipment on vehicles may only be filled to 90% carrying capacity.
- Mobile fuelling tanks must be stored in an area where they are not susceptible to collisions. The fuel storage area must be located away from drainage channels.
- Mobile refuelling operations shall not take place within 30 meters of any watercourses or 7.5 meter from other structures, property lines, public ways or combustible storage.
- All mobile refuelling tanks are to be properly labelled and fire extinguishers with valid service dates shall be located near the fuel storage areas. These extinguishers must be of a suitable type and size.

1.6. Spill Response

The Contractor shall have adequate spill response materials/equipment on site which must be aligned with the volumes of hazardous substances used on site and the risk of pollution to sensitive environmental attributes.

The Contractor shall provide details for approval by the Transnet CM and Transnet EO of its spill response plan in the event of any spills of fuel, oils, solvents, paints or other hazardous materials. The plan will show measures to be taken in removing contaminated material from site and demonstrate complete removal of contamination.

The Contractor shall instruct construction personnel on the following spill prevention and containment responsibilities:

- Immediately repair all leaks of hydrocarbons or chemicals;
- Take all reasonable means to prevent spills or leaks;
- Do not allow sumps receiving oil or oily water to overflow;
- Prevent storm water runoff from contamination by leaking or spilled drums of oil or chemicals; and
- Do not discharge oil or contaminants into storm water or sewer systems.

If a spill occurs on land, the Contractor must:

- Immediately stop or reduce the spill
- Contain the spill
- Recover the spilled product
- Remediate the site
- Implement actions necessary to prevent the spill from contaminating groundwater or off-site surface water
- Dispose of contaminated material at a registered hazardous waste disposal site and provide proof thereof (SDCs)

Any spill to water has the potential to disperse quickly, therefore, the spill must be contained immediately using appropriate containment equipment.

If a spill to water occurs, the Contractor must:

- Take immediate action to stop or reduce the spill and contain it
- Notify the appropriate on-site authorities
- Implement actions necessary to prevent the spread of the contamination by deploying booms and/or absorbent material

- Recover the spilled product
- Dispose of spilled material at a registered hazardous waste disposal site and provide SDCs
- Water samples to be taken downstream from where the spill took place to trace the extent of pollution

1.7. Spray Painting and Sandblasting

Spray painting and sandblasting should be kept to a minimum. All painting should, as far as practicable, be done before equipment and material is brought on site. Touch-up painting is to be done by hand painting or by an approved procedure. A Method Statement shall be submitted to the Transnet EO for approval.

The relevant Contractor will inform his EO of when and where spray painting or sandblasting is to be carried out prior to commencement of work. The Contractor's EO will monitor these activities to ensure that adequate measures are taken to prevent contamination of the soil.

If the area is in confined or high (elevated) areas, a protection plan must be issued for approval by the Transnet EO.

1.8. Dust Management

Current best practice relating to the management of dust in construction site, discourages the use of water intensive dust control measures.

Contractors are responsible for managing dust generated as a result of their activities; the usage of water for dust management to be minimised as far as practically possible. Discretion to be applied on a site-by-site basis in terms of dust control. Dust control measures must be agreed upon by the Transnet EO prior to commencement of the Works.

Below are some dust control measures which can be applied during construction are presented in this section for inclusion by the Contractor in his Dust Control Method Statement:-

- Operate vehicles within speed limits, where no speed limit has been specified, the limit shall be 20km/h;
- Minimise haulage distances where possible;
- Environmentally friendly soil stabilisers may be used as additional measures to control dust on gravel roads and construction areas;
- The introduction of hydro-seeding and mulch due to its ability to bind soil particles together and thus reduce fugitive dust on-site;
- Dust suppression measures will also apply to inactive construction areas. (An inactive construction site is one on which construction will not occur for a month or more);
- Minimise disturbance of natural vegetation during right-of-way construction (e.g. transmission lines and erection of fences) to reduce potential erosion, runoff, and airborne dust;
- Material in transit should be loaded and contained within the load bin of the vehicle in such a way as to prevent any spillage onto the roads and the creation of dust clouds. If necessary, the load bin of the vehicle shall be covered with a tarpaulin to prevent dust;
- Implement a system of reporting excessive dust conditions by construction personnel (as instructed through Environmental Awareness Training);
- In cases where water is to be used for dust control; it shall be ensured that it shall only be taken from authorised sources; and
- Apply water to gravel roads with a spraying truck when required, however taking due regard to the current water shortages in the country;

1.9. Storm water and Dewatering Management

The Contractor shall be aware that, apart from runoff from overburden emplacements and stock piles, storm water can also be contaminated from batch plants, workshops, vehicle wash-down pads, etc., and that contaminants during construction may include hydrocarbons from fuels and lubricants, sewerage from employee ablutions and excess fertiliser from rehabilitated areas, etc.

The Contractor shall take note that discharges to controlled waters such as the sea, rivers, groundwater or to sewerage systems are controlled under the South African Water Legislation. The following specific measures are required:

- Temporary drainage must be established on site during the construction period until permanent drainage is in place. Contractors are responsible for maintaining the temporary drainage in their areas. Contractors must provide secondary drainage that prevents erosion, where necessary.
- Contractors must employ good housekeeping in their areas to prevent contamination of drainage water.
- The Contractor shall clear stagnant water at all times.
- The Contractor shall ensure that no contaminated surface water flows off-site as a result of Contractor operations. Where necessary, silt traps shall be constructed to ensure retention of silt on site and cut-off ditches shall be constructed to ensure no runoff from the site except at points where silt traps are provided. The Contractor shall be responsible for checking and maintaining all silt traps for the duration of the project.
- The removal from groundwater is defined as a water-use under the National Water Act 36 of 1998. Therefore, it must be ensured that the project has been authorised by the Responsible Authority to remove groundwater prior to dewatering taking place. If applicable, the Contractor shall be responsible for collection, management, and containment within the site boundaries of all dewatering from all general site preparation activities.

- The dewatering water shall be contained within the site boundaries and executed in a manner that is in line with the Dewatering Method Statement.
- No discharge/dewatering to off-site land or surface water bodies will be allowed
- On-site drainage shall be accomplished through gravity flow. The surface drainage system shall consist of mild overland slopes, ditches, and culverts. The graded areas adjacent to buildings shall be sloped away with a 5% slope. Other areas shall have a minimum slope of 0,2% or as otherwise indicated
- Ditches shall be designed to carry a 25-year storm event with velocities in accordance to minimise erosion. Erosion protection shall consist of suitable stabilising surfaces in all ditches.
- Culverts shall be designed to ensure passage of the 50-year storm peak runoff flow.

1.10. Erosion Control

Other structural and non-structural (vegetative) erosion control measures will be designed, implemented, and properly maintained in accordance with best management practices which will include, but not limited to the following:

- Scheduling of activities to minimise the amount of disturbed area at any one time;
- Implementation of re-vegetation as early as feasible;
- Limiting construction traffic and/or avoidance thereof on access roads and areas to be graded to the extent feasible at drainage ditches;
- Compacting loose soil as soon as possible after excavation, grading, or filling;
- Using silt fences, geo-textiles, temporary rip-rap, soil stabilisation with gravel, diversionary berms or swales, small sedimentation basins, and gravelled roads to minimise transport of sediment;
- Implementing the erosion and sedimentation control plan and ensuring that construction personnel are familiar with and adhere to it;

- Managing runoff during construction; and
- The Contractor shall be responsible for checking and maintaining all erosion and sedimentation controls.

1.11. Noise Management

The Contractor must implement the following measures, as a minimum, to manage noise pollution resulting from his/her activities:-

- Keep all equipment in good working order;
- Operate equipment within its specification and capacity and don't overload machines;
- Apply regular maintenance, particularly with regards to lubrication;
- Operate equipment with appropriate noise abatement accessories, such as sound hoods;
- Sensitive social receptors shall be notified of any excessive noise-generating activities that could affect them;
- Ensure that the potential noise source will conform to the South African Bureau of Standards recommended code of practice, *SANS 10103:2004* or the latest at the time, so that it will not produce excessive or undesirable noise when released;
- All the Contractor's equipment shall be fitted with effective exhaust silencers and shall comply with the South African Bureau of Standards recommended code of practice, *SANS 10103:2004* or the latest at the time, for construction plant noise generation

- All the Contractor's vehicles shall be fitted with effective exhaust silencers and shall comply with the Road Traffic Act, (Act 29 of 1989) when any such vehicle is operated on a public road
- If on-site noise control is not effective, protect the victims of noise by ensuring that all noise-related occupational health provisions are met. (Occupational Health and Safety Act, (Act 85 of 1993).

1.12. Protection of heritage resources

1.12.1. Archaeological Sites

If an artefact on site is uncovered, work in the immediate vicinity shall be stopped immediately. The Contractor shall take reasonable precautions to prevent any person from removing or damaging any such article and shall immediately upon discovery thereof inform the Transnet CM and Transnet EO of such a discovery. The South African Heritage Resources Agency (SAHRA) or relevant Authority is to be contacted and will appoint an Archaeologist to investigate the find. Work may only resume once clearance is given in writing by the Archaeologist.

1.12.2. Graves and middens

If a grave or midden is uncovered on site, or discovered before the commencement of work, all work in the immediate vicinity of the graves/middens shall be stopped and the Transnet CM and Transnet EO informed of the discovery. The South African Heritage Resources Agency (SAHRA) or relevant Authority should be contacted and in the case of graves, arrangements made for an undertaker to carry out exhumation and reburial. The undertaker will, together with the SAHRA, be responsible for attempts to contact family of the deceased and for the site where the exhumed remains can be re-interred.

1.13. Fire prevention

Fires shall only be allowed in facilities or equipment specially constructed for this purpose.

A firebreak shall be cleared and maintained around the perimeter of the camp and office sites where and when necessary. In cases where construction is taking place in a Critical Biodiversity Area as listed under NEM:BA; it must be ensured that the requirement of a firebreak is screened against the NEMA Listing Notice 3 to confirm legislative requirements.

All conditions incorporated in the requirements of the Occupational Health and Safety Act shall be implemented.

1.14. Water Protection and Management

No water shall be abstracted from any water course (stream, river, or dam) without the expressed permission of the Transnet CM and Transnet EO. Such permission shall only be granted once it can be shown that the water is safe for use, that there is sufficient water in the resource to meet the demand, and once permission has been obtained from the Department of Water and Sanitation in accordance with the requirements of the National Water Act (Act 36 of 1998).

Water for human consumption shall be available at the site offices and at other convenient locations on site. The generally acceptable standard is that a supply of drinking water shall be available within 200m of any point on the construction site.

Method Statement(s) must be prepared by the Contractor for the various water uses. The Contractor shall keep a record of the quantities of water used during on-site, construction (including use by sub-contractors), irrespective of the purpose of use.

1.15. Protection of Fauna and the collection of firewood

On no account shall any hunting or fishing activity of any kind be allowed. This includes the setting of traps, or the killing of any animal caught in construction works.

On no account shall any animal, reptile or bird of any sort be killed. This specifically includes snakes or other creatures considered potentially dangerous discovered on site. If such an animal is discovered on site an appropriately skilled person should be summoned to remove the creature from the site. Consideration should be given to selection and nomination of such a person prior to site establishment. If no-one is available, training should be provided to at least two site staff members.

The Contractor shall provide adequate facilities for all his staff so that they are not encouraged to supplement their comforts on site by accessing what can be taken from the natural surroundings. The Contractor shall ensure that energy sources are available at all times for construction and supervision personnel for heating and cooking purposes.

1.16. Environmental Awareness Training

An Environmental Awareness Program is considered a necessary part of the Construction Environmental Management Plan for the Project. Training of the appropriate construction personnel will help ensure that all environmental regulations and requirements are followed which must be defined in the relevant Method Statement to be prepared by the Contractor.

Objectives of environmental awareness training are:

- Environmental Management – protecting the environment from the effects of construction by making personnel aware of sensitive environmental resources.
- Regulatory compliance – complying with requirements contained in project – specific permit conditions, also complying with requirements in regional and local regulations.
- Problem recognition and communication – training personnel to recognise potential environmental problems, i.e. spills, and communicate the problem to the Contractor's EO for a solution.
- Liability control - non-compliance with regulatory requirements can lead to personal and corporate liability.

All individuals on the Project will need to have a minimum awareness of environmental requirements and responsibilities. However, not all need to have the same degree of awareness. The required degree of knowledge is greatest for personnel in the Safety, Health, and Environmental Sections and the least for the manual personnel.

The Contractor shall present environmental awareness programmes on a weekly/bi-monthly basis (depending on project requirements) and keep record of all the environmental related training of the personnel.

1.17. Handling and Batching of Concrete and Cement

Concrete batching shall only be conducted in demarcated areas which have been approved by the Transnet CM and Transnet EO.

Such areas shall be fitted with a containment facility for the collection of cement-laden water. This facility shall be bunded and have an impermeable surface protection so as to prevent soil and groundwater contamination. Drainage of the collection facility will be separated from any infrastructure that contains clean surface runoff.

The batching facility will not be placed in areas prone to floods or the generation of stagnant water. Access to the facility will be controlled so as to minimise potential environmental impacts. Hand mixing of cement and concrete shall be done on mortarboards and/or within the bunded area with impermeable surface or concrete slab. Bulk and bagged cement and concrete additives will be stored in an appropriate facility at least 10m away from any watercourses, gullies and drains.

Waste water collected in the containment facility shall be left to evaporate. The Contractor shall monitor water levels to prevent overflows from the facility. It is acknowledged that all waste water will evaporate; it must be ensured that the remaining water can be pumped into sealed drums for temporary storage and must be disposed of as liquid hazardous waste.

All concrete washing equipment, such as shovels, mixer drums, concrete chutes, etc. shall be done within the washout facility. Water used for washing shall be restricted as far as practically possible.

Ready-mix concrete trucks are not allowed to wash out anywhere other than in an area designated and approved by the Transnet CM and Transnet EO for this purpose.

The Contractor shall periodically clean out hardened concrete from the wash-out facility or concrete mixer, which can either be reused or disposed of as per accepted waste management procedures.

Empty cement and bags, if temporarily stored on site, must be collected and stored in weatherproof containers. Used cement bags may not be used for any other purpose and must be disposed of on a regular basis in accordance with the Contractor's solid waste management system.

Sand and aggregates containing cement will be kept damp to prevent the generation of dust.

Concrete and cement or any solid waste materials containing concrete and cement will be disposed of at a relevant registered disposal facility and SDCs kept on the file. Where disposal facilities for general waste are utilised, written consent from the relevant municipality must be obtained by the Contractor and filed in the Green file.

1.18. Stockpiling, Soil Management and Protection of Flora

The Contractor shall measure the extent of all areas cleared for construction purposes and keep this figure updated. Sensitive areas shall be cordoned off and avoided in this regard.

Stockpiling may only take place in designated areas indicated on the approved site layout plan. Any area to be used for stockpiling or material laydown shall be stripped of all topsoil.

Clearance of vegetation shall be restricted to that which is required to facilitate the execution of the works. Vegetation clearance shall occur in a planned manner, and cleared areas shall be stabilised as soon as possible when and where necessary. The detail of vegetation clearing shall be subject to the Transnet CM's approval and shall occur in consultation with the Transnet EO.

Stockpiles must be positioned in areas sheltered from the wind and rain to prevent erosion and dispersion of loose materials. Stockpiled soil shall be protected by adequate erosion-control measures. Soil stockpiles shall be located away from drainage lines, watercourses and areas of temporary inundation. Stockpiles containing topsoil shall not exceed 2m in height unless otherwise permitted by Transnet.

Topsoil shall be stockpiled separately from other materials and prevented from movement. Excavated subsoil, where not contaminated, must be used for backfilling, if possible, and topsoil for landscaping and rehabilitation of disturbed areas. Where topsoil has become mixed with subsoil or is not up to the original standard, fertiliser or new topsoil shall be provided by the Contractor.

No vegetation located outside the construction site shall be destroyed or damaged. As far as is reasonably practicable, existing roads must be used for access to the site. Before site clearance takes place, vegetation surveys must be conducted and protected species identified.

No protected plant species shall be removed without written consent from the relevant authorities. The development of new embankments or fill areas must be undertaken in consultation with the Transnet EO.

No dumping of solid waste or refuse shall be allowed within or adjacent to areas of natural vegetation.

The Contractor shall identify and eradicate all declared alien and invasive plant species occurring on site.

1.19. Traffic Management

Vehicles usage is permitted **only** on access roads. Vehicles should only be parked within designated parking areas as demarcated on the site layout plan.

Turning of vehicles should only take place within a clearly demarcated "turn area" located within the approved construction footprint.

The Contractor must co-ordinate the loading and offloading of material during the construction phase so as to ensure that vehicular movement is in one direction only at any one time and that side-tracks are not created on the site.

1.20. Transportation of Materials

The Contractor is responsible for ensuring that all suppliers and delivery drivers are aware of procedures and restrictions (e.g. no-go areas) in terms of the CEMP and this Specification. Material must be appropriately secured to ensure safe passage between destinations during transportation. Loads must have appropriate cover, where ADTs are not utilised, to prevent spillage from the vehicles. The Contractor will be held responsible for any clean-up resulting from the failure to properly secure transported materials.

1.21. Borrow Pits and Quarries

The Contractor shall ensure that suppliers of rock and sand raw materials are in possession of the required permit/license and keep record of the quantity of material supplied.

The Contractor will not make direct use of any borrow pits and quarries unless the borrow pit has a valid permit, he has obtained written approval from the Transnet CM and Method Statement has been submitted and approved. The Method Statement will provide the detailed description of the location of the borrow pits and/or quarries and the procedures that will be followed to adhere to any pertinent national or local legislation (e.g. mineral extraction, rehabilitation, safety and noise levels).

1.22. Social and Labour Issues

The criteria for and selection of labourers, sub-contractors and suppliers for the project shall demonstrate preference for the local community and shall be aligned with the criteria set by

Transnet in appointing the Contractor. The Contractor shall keep records of the identity of all staff.

Under no circumstances shall the Contractors engage in formal discussions with landowners without prior consent by the Transnet CM.

No activity on private property shall be allowed without written consent by the relevant landowner and Transnet CM or Transnet EO.

Any damage to private property caused by the Contractor during the construction period, shall be repaired to the satisfaction of the Transnet CM and the Transnet EO and the landowner.

The Contractor shall keep record of any complaint raised during the construction period relating to the Contractor's activities.

No job-seekers shall be allowed on site and signs reflecting such shall be displayed on the notice boards.

All public complaints received shall be dealt with as per 013 Occurrence and Non conformance management.

1.23. Energy Management

The Contractor shall measure and keep updated records of the following:

- Electricity consumption (to be measured in Kilowatt Hours)
- Fuel consumption (to be measured in liters)

1.24. Handling, Storage and Management of Hazardous Substances

All hazardous materials/substances shall be stored in a secured, designated area that is fenced, bunded and has restricted entry.



All storage shall take place using suitable containers to the approval of the Transnet CM and the Transnet EO.

All hazardous liquids shall be located in a secure, demarcated area and an adequate bund wall (110% of the total volume stored) shall be provided. The floor and wall of the bund area shall be impervious to prevent infiltration of any spilled/leaked liquids into the soil.

No spillages or accumulated stormwater within this bunded area will be allowed to be flushed from the bund into the surrounding area. All fluids accumulated within the bunded area shall be removed and disposed of in accordance with **Section 4.3**.

Hazard signs indicating the nature and volume of the stored materials shall be displayed on the storage facility or containment structure.

Weighbills of hazardous substances shall be sourced from suppliers and kept on site for inspection by the Transnet EO.

The Contractor must provide a method statement detailing the hazardous substances that are to be used during construction, as well as the storage, handling and disposal procedures for each substance. Emergency procedures in the event of misuse or spillage that might negatively affect the environment must be specified.

Information on each hazardous substance will be available to all persons on site in the form of Material Safety Data Sheets (MSDS)/Safety Data Sheets (SDS). Training and education about the proper use, handling, and disposal of the material will be provided to all workers handling the material.

The Contractor's EO must be informed of all activities that involve the use of hazardous substances to facilitate prompt response in the event of a spill or release.

1.25. Housekeeping

The Contractor must ensure proper housekeeping of the site for the duration of the project. If practical the contractor shall amongst construction personnel, assign one to be responsible for good housekeeping

Materials shall be stored in a neat and tidy manner in designated areas as per the approved site layout plan.

1.26. Rehabilitation

Contractors shall rehabilitate the entire site upon completion of work. A rehabilitation plan will be submitted to the Transnet CM and the Transnet EO for approval at least six weeks before project completion. The following, but not limited are critical issues to be included in the rehabilitation plan:

- Details of soil preparation procedures including proposed fertilisers or other chemicals being considered for use;
- A list of the plant species that will be used in the rehabilitation process. Note that these should all be indigenous species, and preferably species that are endemic to the area. The assistance of an appropriately qualified Botanist/Horticulturist should be sought in developing this list;
- Procedures for watering the planted areas (frequency of watering, methodology proposed etc.);
- An indication of the monitoring procedures that will be put in place to ensure the successful establishment of the plants (duration and frequency of monitoring, proposed criteria for declaring rehabilitation as being successful); and
- Procedures for the prevention of the establishment and spread of alien invasive species.

5 Documentation

Refer to 010 Document Data and Record control procedure.



6 Records

All documents generated in terms of this procedure will be classed as records and retained for the life of the project for handover by the contractor to Transnet (electronic and hard copies).

Contractor Health and Safety Specification Guidelines

Table of Contents

1. Purpose.....	6
2. Scope	6
3. Definitions	6
4. Abbreviations	11
5. SHE Management Plan	11
6. Policy	13
7. Hazard Identification and Risk Assessment.....	13
7.1 Baseline Risk Assessments.....	14
7.2 Task-Based Risk Assessments	15
7.3 Pre-Task Hazard Assessments.....	16
8. Legal and Other Requirements.....	16
9. Objectives.....	16
10. Resources, Accountabilities and Responsibilities	17
10.1 Contractor Construction Manager	18
10.2 Contractor Health and Safety Officers.....	20
10.3 Contractor Supervisors	21
10.4 Health and Safety Representatives	23
10.5 First Aiders	23
10.6 Duties of Client	23
10.7 Duties of the Designer.....	25
10.8 Duties of Principal Contractor.....	26
10.9 Duties of Contractor	27
10.10 Management and supervision of Construction work.....	28
10.11 Construction Health and Safety Agent	28
10.12 Operational legal appointment letters.....	29
11. Safety Agents in Project Stages	30
11.1 Stage 1 – Project Initiation and Briefing	30
11.2 Stage 2 – Concept and Feasibility	30
11.3 Stage 3 – Design Development.....	31
11.4 Stage 4 - Tender Documentation and Procurement.....	32
11.5 Stage 5 - Construction Documentation and Management	33
11.6 Stage 6 - Project Close - Out.....	34
11.7 Additional Related Services	34
12. Competence, Training and Awareness	35
12.1 Induction Training.....	37
12.2 Specific Training and Competency Requirements	37

13. Communication, Participation and Consultation.....	38
13.1 Toolbox Talks	38
13.2 Daily Safe Task Instructions (DSTI's).....	38
13.3 Suggestions.....	39
13.4 Meetings	39
13.5.1 Contractor health and safety (OHS Act Section 19)	39
13.5.2 Site Meetings.....	39
13.5 Performance Boards	40
13.6 Management Information Notice Boards.....	40
13.7 Involvement (Other)	41
14. Documentation and Document Control.....	41
14.1 Contractor compliance File Requirements	42
15. Notification of Construction Work.....	43
16. Operational Control	43
16.1 Project-Specific SHE Standards	43
16.2 Safe Work Procedures	43
16.3 Management Participation and involvement CR 8	44
16.4 Planned Task Observations	44
16.5 General Rules of Conduct	44
16.6 Site Access	45
16.6.1 Access Control	45
16.6.2 Trespassing	45
16.6.3 Visitors	46
16.6.4 Alcohol, Drugs and Other Intoxicating Substances.....	46
16.6.5 Firearms, Ammunition and Offensive Weapons	46
16.6.6 Vehicles.....	47
16.7 Mobile Equipment and Light Vehicles.....	48
16.7.1 Light Vehicles	51
16.7.2 Mobile Equipment	54
16.7.3 Training and Licensing	56
16.7.4 Tyre and Rim Safety.....	56
16.7.5 Roads57	
16.8 Signs and Notices	58
16.9 Machinery.....	58
16.10 Barricading	59
16.11 Excavations	60
16.12 Cranes and Lifting Equipment	65
16.12.1 Design, Manufacturing and Safety Features	65
16.12.2 Planning and Risk Assessment	67
16.12.3 Operation	68
16.12.4 Inspection, Testing and Maintenance	71
16.12.5 Training and competency	73
16.13 Working at heights.....	73
16.13.1 Fall prevention.....	74

16.13.1.1 Work platforms	74
16.13.1.2 Floor openings, holes and edges	74
16.13.1.3 Wall openings	74
16.13.1.4 Stairways	75
16.13.2 Fall protection.....	75
16.13.3 Risk Assessment and Permitting.....	77
16.13.4 Elevating Work Platforms.....	78
16.13.5 Man Baskets, Suspended Scaffolds and Boatswain’s Chairs	79
16.13.6 Falling Objects	80
16.13.7 Scaffolding	80
16.13.7.1 Training, Competency and Supervision	80
16.13.7.2 Erection and Dismantling of Scaffolding	81
16.13.7.3 Safe Access	83
16.13.7.4 Scaffolding Platforms.....	83
16.13.7.5 Inspection of Scaffolding	84
16.13.7.6 Using Scaffolding	84
16.13.7.7 Identification and Inspection of Scaffolding Components	86
16.13.7.8 Storage of Scaffolding Components	86
16.13.8 Ladders	86
16.14 Permit to Work	88
16.15 Isolation and Lockout	90
16.15.1 Personal Locks	92
16.16 Electrical Safety	93
16.16.1 Electrical Installations.....	94
16.16.2 Arc Flash Safety	96
16.16.3 High Voltage Power Lines	96
16.16.4 Portable Electrical Equipment.....	97
16.17 Confined Spaces	100
16.18 Conveyors	102
16.19 Arc Welding	102
16.20 Gas Welding and Burning	104
16.21 Compressed Gas Cylinders.....	104
16.22 Electrically Powered Tools and Equipment	106
16.22.1 Angle Grinders	106
16.23 Pneumatically Powered Tools and Equipment.....	108
16.24 Fuel Powered Tools and Equipment.....	108
16.25 Hydraulically Powered Tools and Equipment	109
16.26 Explosive Powered Tools	109
16.27 Hand Tools	109
16.27.1 Stanley Knives / Utility Knives	110
16.28 Inspection of Equipment and Tools	110
16.29 Manual Handling and Vibration	110
16.30 Personal Protective Equipment.....	112
16.30.1 Eye Protection	114
16.30.2 Hearing Protection	115
16.30.3 Respiratory Protection	116
16.30.4 Hand and Arm Protection	117
16.30.5 Foot Protection	117

16.30.6 Clothing.....	118
16.30.7 Body Protection	118
16.30.8 Electrical Protective Equipment	119
16.30.9 Jewellery	120
16.30.10 Hair.....	120
16.30.11 Task-Specific PPE.....	120
16.31 Sun Protection	121
16.32 Fuel / Flammable Liquid Storage and Refuelling	121
16.33 Fire Protection and Prevention	123
16.34 Smoking	125
16.35 Housekeeping	125
16.36 Waste Management	126
16.37 Stacking and Storage	126
16.38 Demarcation	127
16.39 Facilities	127
16.40 Occupational Hygiene.....	128
16.41 Lighting	128
16.42 Particulate and Gas / Vapour Exposures	132
16.42.1 Respiratory Protection Devices.....	133
16.42.2 Asbestos and Non-asbestos Fibrous Silicates.....	134
16.43 Hazardous Chemical Substances	135
16.44 Radiation.....	138
16.45 Thermal Stress.....	139
16.46 Fitness for Work	140
16.47 Legionnaires Disease.....	143
16.48 HIV / AIDS	143
17. Occupational Hygiene.....	143
17.1 Lighting.....	144
17.2 Particulate and Gas/ Vapour Exposures (page 127)	144
17.3 Thermal Stress.....	144
17.4 Measuring and Monitoring	145
18. Temporary works	146
19. Structure.....	147
20. Emergency Preparedness and Response.....	148
20.1 Fire Fighting	149
20.2 First Aid.....	149
20.2.1 First Aid Kits	149
21. Management Review	150
22. Management of Change	151
23. Sub-contractor Alignment / Stakeholder management.....	151
24. Measuring and Monitoring	152

25. Incident Reporting and Investigation.....	153
26. Non-conformance and Action Management.....	155
27. Performance Assessment and Auditing.....	155
27.1 Reporting on Performance	155
27.2 Audits and Inspections	156

1. Purpose

This specification development guideline identifies and encompass the working behaviours and safe work practices that are expected of all Transnet SOC Ltd employees, Contractors, Consultant, Visitors and Suppliers, engaged on Transnet managed projects as required by Construction Regulation of 2014, regulation 5(1)(b).

All contractors and service providers must take careful note of these requirements and must ensure that adequate provision has been made to ensure compliance.

This Specification development guideline has been compiled to cover a wide range of construction/ work activities and should serve as a guideline for Safety Agents to develop site specific specifications for construction projects. In order to determine which requirements are applicable, the contractor must conduct a health and safety risk assessment specific to the project and specific to the contractor's scope of work. All applicable requirements must be addressed in the Contractor's Health and Safety Management Plan.

This Specification development guideline will be reviewed and updated periodically as and when necessary) to address and / or include:

- Changes in legislation;
- Client requirements;
- Leading practices; and
- Lessons learnt from incidents.

The specification development guideline provides the minimum requirements for site specific specification and should be used as a guide to develop the site specific specification as it is required by the Construction Regulation of 2014.

2. Scope

This Specification applies to all project sites, and to all persons working on or visiting the Transnet managed projects. The requirements specified in this document are applicable to the contractor as well as any sub-contractors, EPCM Contractors, Consultant, Vendors and Visitors that may be appointed by Transnet as an Employer. It is the contractor's responsibility to ensure that all sub-contractors comply fully with all legal requirements as well as the requirements of this health and safety specification.

3. Definitions

Acceptable Risk

A risk that has been reduced to a level that can be tolerated having regard for the applicable legal requirements and the Health and Safety Policy adopted for the project.

ALARP (As Low As Reasonably Practicable)

The concept of weighing a risk against the sacrifice needed to implement the measures necessary to avoid the risk. With respect to health and safety, it is assumed that the measures should be implemented unless it can be shown that the sacrifice is grossly disproportionate to the benefit.

Applicant (Permit to Work)

A person requesting permission to perform work for which a Permit to Work is required. Applicants must be authorised (in writing) to receive (or accept) Permits to Work and must be competent to do so by virtue of their training, experience and knowledge of the area or plant in which the work is to be performed.

Authorised Person (Permit to Work)

A person (typically a Project employee or an employee of the client) who has been authorised (in writing) by the nominated project management representative to issue Permits to Work within the scope of his designation. A person may only be appointed to issue Permits to Work if he has undergone training and has been assessed and found competent in systems, plant and equipment operation within the scope of his designation.

Barricade

A temporary structure that is erected as a physical barrier to prevent persons from inadvertently coming into contact with an identified hazard.

Battering

Sloping the sides of an excavation to a predetermined angle (usually less than the natural angle of repose) to ensure stability.

Benching

The creation of a series of steps in the sides of an excavation to prevent collapse.

Consequence

The outcome of an event expressed qualitatively or quantitatively.

Contractor

An employer (organisation) or a person who performs **ANY** work and has entered into a legal binding business agreement contract to supply a product or provide services to Transnet. This applies to the Suppliers, Vendors, and Consultants, Service providers or Contractors performing construction work

NB: A Contractor is an employer in his/her own right

Competent Person

A person who has in respect of the work or task to be performed the required knowledge, training, experience and as per act cr2014.

Construction Supervisor

A competent person responsible for supervising construction activities on a construction site

Clearance Certificate

A signed declaration by an Isolation Officer that a specified hazardous energy source associated with a particular system, plant or item of equipment has been isolated in accordance with an approved Isolation and Lockout Procedure.

Discipline Lock (many locks with a restricted number of identical keys)

Attached at a Lockout Station or at a Local Isolation Point in order to lock out a system, plant or equipment. A Discipline Lock (e.g. A Low Voltage Electricity Discipline Lock) is owned by an

Isolation Officer who has been authorised in writing to isolate and lockout a particular hazard (e.g. Low voltage electricity).

Equipment Lock (many locks with one unique key)

Attached directly to pieces of equipment in order to lock them out. Equipment Locks may only be used by Isolation Officers who have been authorised in writing to perform isolation and lockout procedures. The key must have a solid key ring that fits over an Isolation Bar.

Excavation

Any man-made cut, cavity, pit, trench, or depression in the earth's surface formed by removing rock, sand, soil or other material using tools, machinery, and / or explosives. Tunnels, caissons and cofferdams are specifically excluded and are not addressed in this standard.

First-Aid Injury (FA)

A first-aid injury is any one time treatment and any follow up visit for observation of minor scratches, cuts, burns, splinters and the like which do not normally require medical care. Such treatment is considered to be first aid even if administered or supervised by a medical practitioner. First aid includes any hands on treatment given by a first aider. (E.g. Band-Aid, washing, cleansing, pain, relief). The following procedures are generally considered first aid treatment:

- Application of Antiseptics.
- Application of Butterfly adhesive dressing or sterile strips for cuts and lacerations.
- Administration of tetanus shot(s) or booster(s). However, these shots are often given in conjunction with more serious injuries, consequently injuries requiring these shots may be recordable for other reasons.
- Application of bandages during any visit to medical personnel.
- Application of ointments to abrasions to prevent drying or cracking.
- Inhalation of toxic or corrosive gas, limited to the removal of the employee to fresh air or the one time administration of oxygen for several minutes.
- Negative X-Ray diagnosis.
- Removal of foreign bodies not embedded in the eye if only irrigation is required.
- Removal of foreign bodies from a wound if procedure is uncomplicated, for example by tweezers or other simple technique.
- Treatment for first degree burns.
- Use of non-prescription medications and administration of single dose of prescription medication on first visit for any minor injury or discomfort.

Hazard

A source of potential harm in terms of human injury or ill health, or a combination of these.

Hierarchy of Controls

A sequence of control measures, arranged in order of decreasing effectiveness, used to eliminate or minimise exposure to workplace health and safety hazards:

- Elimination – Completely removing a hazard or risk scenario from the workplace.
- Substitution – Replacing an activity, process or substance with a less hazardous alternative.
- Isolation (Engineering) Controls – Isolating a hazard from persons through the provision of mechanical aids, barriers, machine guarding, interlocks, extraction, ventilation or insulation.
- Administrative Controls – Establishing appropriate policies, procedures and work practices to reduce the exposure of persons to a hazard. This may include the provision of specific training and supervision.
- Personal Protective Equipment – Providing suitable and properly maintained PPE to cover and protect persons from a hazard (i.e. Prevent contact with the hazard).

Isolation and Lockout Procedure

A plant or equipment-specific procedure that describes the method, and sequence to be followed, for rendering equipment, plant and systems safe to work on.

Isolation Bar

A device used at a Lockout Station to which anyone is able to attach a Personal Lock making it impossible for an Isolation Officer to remove the key to the Equipment Locks, thus preventing the de-isolation of a system, plant or equipment while it is still being worked on. A Discipline Lock must always be the first lock attached to an Isolation Bar and last to be removed.

Isolation Officer

A person (typically a Project employee or an employee of the client) who has been authorised (in writing) by the nominated project management representative to perform isolation and lockout procedures. A person may only be appointed as an Isolation Officer if he has undergone training and has been assessed and found competent in the isolation and lockout of systems, plant and equipment within the scope of his designation.

Incident

An event (or a continuous or repetitive series of events) that results or has the potential to result in a negative impact on people (employees, contractors and visitors), the environment, operational integrity, assets, community, process, product, legal liability and / or reputation.

Likelihood

A description of probability or frequency, in relation to the chance that an event will occur.

Lost Time Injury (LTI)

Any occurrence that resulted in a permanent disability or time lost from work of one day/shift or more.

If an employee is injured and cannot return to work in the next shift (will ordinarily miss one whole shift), and the department brings the employee in to only receive treatment by the Supervisor/ Return to Work Coordinator in that shift, this is still considered an LTI.

Lost Time Injury Frequency Rate (LTIFR) - Number of LTI's multiplied by 1 million or 200,000 and divided by labour hours worked.

Light Vehicle

A vehicle that:

- Can be licensed and registered for use on a public road;
- Has four or more wheels, and seats a maximum of 12 adults (including the driver);
- Requires the driver to hold only a standard civil driving licence; and
- Does not exceed 4.5 tonnes gross vehicle mass (GVM), which is the maximum loaded mass of the motor vehicle as specified by:
 - ◆ The vehicle's manufacturer; or
 - ◆ An approved and accredited automotive engineer, if the vehicle has been modified to the extent that the manufacturer's specification is no longer appropriate.

Examples of light vehicles include passenger cars, four-wheel drive vehicles, sports utility vehicles (SUVs), pick-ups, minibuses, and light trucks.

Any vehicle falling outside of this definition must be considered mobile equipment.

Medical Treatment Injury (MTI)

A work injury requiring treatment by a Medical Practitioner and which is beyond the scope of normal first aid including initial treatment given for more serious injuries. The procedure is to be of an invasive nature (e.g. Stitches, removal of foreign body).

The following procedures are generally considered medical treatment:

- Application of sutures (stitches).
- Cutting away dead skin (surgical debridement).
- Loss of consciousness due to an injury or exposure in the work environment.
- Positive X-Ray diagnosis (fractures, broken bones etc.).
- Removal of foreign bodies embedded in the eye.
- Removal of foreign bodies from the wound by a physician due to the depth of embedment, size or shape of object or the location wound.
- Reaction to a preventative shot administered because of an occupational injury.
- Sprains and strains - series (more than one) of hot and cold soaks, use of whirlpools, diathermy treatment or other professional treatment.
- Treatment of infection.
- Treatment for second or third degree burns
- Use of prescription medications (except a single dose administered on first visit for minor injury or discomfort.)

Mobile Equipment

A vehicle (wheeled or tracked) that generally requires:

- The driver to hold a specific state or civil license; or
- The operator to hold a nationally recognized certificate of competency.

Examples of mobile equipment include, but are not limited to, dump trucks, water trucks, graders, dozers, loaders, excavators, forklifts, tractors, back-actors, bobcats, mobile cranes, tele-handlers, drill rigs, buses and road-going trucks.

Near Hit

An incident that has occurred that did not result in any injuries, illnesses, environmental or property damage but had the potential to cause an injury, illness, environmental or property damage.

Personal Lock

A single lock with one unique key controlled by the owner. Used for personal protection.

Regulation

In the context of this guideline, 'Regulation(s)' refers to the Construction Regulations, 2014 required by Section 43 of the Occupational Health and Safety Act 85 of 1993, published under Government Notice R 84 in Government Gazette 37305 of February 2014.

Risk

A combination of the likelihood of an occurrence of a hazardous event or exposure and the severity of injury or ill health that can be caused by the event or exposure.

Risk Assessment

A process of evaluating the risk arising from a hazard, taking into account the adequacy of any existing control measures, and deciding on whether or not the risk is acceptable.

Risk Management

The systematic application of management policies, processes and procedures to identifying hazards, analysing and evaluating the associated risks, determining whether the risks are acceptable, and controlling and monitoring the risks on an ongoing basis.

4. Abbreviations

DSTI - Daily Safety Task Instruction

CR – Construction Regulations

EPC - Engineering Procurement and Construction

EPCM - Engineering Procurement and Construction Management

HIRA - Hazard Identification and Risk Assessment

HEALTH AND SAFETY - Integrated Management System

MS - Management System

OHS Act - Occupational Health and Safety Act

SOC - Safety Observation and Conversation

VFL - Visible Felt Leadership

OHS - Occupational Health and Safety

SACPCMP - The South African Council for Project and Construction Management Professions, here in refer to as they register of Health and Safety Professionals

5. SHE Management Plan

The contractor must prepare, implement and maintain a project-specific SHE Management Plan. The plan must be based on the requirements set out in this specification as well as all applicable legislation. It must cover all activities that will be carried out on the project site(s), from mobilisation and set-up through to rehabilitation and decommissioning.

The plan must demonstrate the contractor's commitment to HEALTH AND SAFETY and must, as a minimum, include the following:

- A copy of the contractor's **Health and Safety Policy**; in terms of the OHS Act section 7
- Procedures concerning **Hazard Identification and Risk Assessment**, including both Baseline and Task-Based Risk Assessments;
- Arrangements concerning the identification of applicable **Legal and Other Requirements**, measures to ensure compliance with these requirements, and measures to ensure that this information is accessible to relevant personnel;
- Details concerning **Health and Safety Objectives** – a process must be in place for setting objectives (and developing associated action plans) to drive continual improvement;
- Details concerning **Resources, Accountabilities and Responsibilities** – this includes the assignment of specific health and safety responsibilities to individuals in accordance with legal or project requirements, including the appointment of a Project Manager, Health and Safety Officers, Supervisors, Health and Safety Representatives, and First Aiders;

- Details concerning **Competence, Training and Awareness** – a system must be in place to ensure that each employee is suitably trained and competent, and procedures must be in place for identifying training needs and providing the necessary training;
- **Communication, Participation and Consultation** arrangements concerning health and safety, including Safety Observations and Coaching, Toolbox Talks, Daily Safe Task Instructions, project health and safety meetings, and notice boards;
- **Documentation and Document Control** – project-specific documentation required for the effective management of health and safety on the project must be developed and maintained, and processes must be in place for the control of these documents;
- Processes and procedures for maintaining **Operational Control**, including rules and requirements (typically contained in Safe Work Procedures) for effectively managing health and safety risks, particularly critical risks associated with working at heights, confined spaces, mobile equipment and light vehicles, lifting operations, hazardous chemical substances, etc.;
- **Emergency Preparedness and Response** procedures;
- **Management of Change** – a process must be in place to ensure that health and safety risks are considered before changes are implemented;
- **Sub-contractor Alignment** procedures – a process must be in place for the assessment of sub-contractors and suppliers with regard to health and safety requirements and performance (before any contract or purchase order is awarded);
- **Measuring and Monitoring** plans, including a plan for the measuring and monitoring of employee exposure to hazardous substances or agents (e.g. Noise, dust, etc.) In order to determine the effectiveness of control measures;
- **Incident Reporting and Investigation** procedures describing the protocols to be followed with regard to incident reporting, recording, investigation and analysis;
- **Non-conformance and Action Management** procedures concerning the management of corrective actions;
- **Performance Assessment and Auditing** procedures concerning health and safety performance reporting, monthly internal audits to assess compliance with the project health and safety requirements, and daily site health and safety inspections; and
- Details concerning the **Management Review** process followed to assess the effectiveness of health and safety management efforts.

Prior to mobilisation, the HEALTH AND SAFETY Management Plan must be forwarded electronically, and as a hard copy, to the nominated project management representative for review. The plan will be audited for completeness and, if found to be adequate, will be accepted (typically “with comments”). Work may not commence until the plan has been accepted.

Once the plan has been accepted, the contractor must action and resolve any issues within 30 days from the start of work.

If the issues requiring corrective action are not resolved within this 30 day period, the contractor will be required to stop any work related to the outstanding actions until they have been resolved.

Any proposed amendments or revisions to the contractor’s Health and Safety Management Plan must be submitted to the nominated project management representative for acceptance.

Should it be identified that the contractor has overlooked a high risk activity, and as a result has omitted the activity and associated control measures from the Health and Safety Management Plan, the plan will not be approved.

6. Policy

The contractor must develop, display and communicate a Health and Safety Policy that clearly states the contractor's values and objectives for the effective management of health and safety as required by OHS Act of 1993, 7(3). These values and objectives must be endorsed by the contractor's management representatives and must be consistent with those adopted for the project.

The policy must be signed and dated, and must be reviewed annually.

The policy must commit to:

- Compliance with all applicable legal requirements in the TCP regulatory universe;
- The effective management of health and safety risks;
- The establishment of measurable objectives for improving performance, and the provision of the necessary resources to meet these objectives;
- The prevention of incidents; and
- Achieving continual improvement with regard to health and safety performance.

All employees of the contractor as well as the employees of any sub-contractors that may be appointed by the contractor must be made aware of the policy. This must be done through Health and Safety Induction Training and Toolbox Talks (refer to Sections 10 and 11).

A copy of the policy must be displayed in each meeting room and on each notice board.

7. Hazard Identification and Risk Assessment.

Detailed hazard identification and risk assessment processes must be followed for all work to be performed as well as for all associated equipment and facilities as required by the Construction regulation of 2014, regulation 9(1) – (7).

The client will provide a baseline risk assessment informing contractor on the hazards and risks on site. Contractor must ensure that effective procedures and risk assessment systems are in place to control hazards and to mitigate risks to levels that are as low as is reasonably practicable.

The risk assessment processes must be applied to:

- The full life cycle of the project;
- Routine and non-routine activities;
- Planned or unplanned changes (refer to Section 15);
- All employees, sub-contractors, suppliers and visitors; and
- All infrastructure, equipment and materials.

The risk assessment processes and methodologies must be appropriate for the nature and scale of the risks, and must be implemented by competent persons.

The process of analysing and managing risk must include the following:

- Establishing the context of the risk assessment;

- Identifying hazards and determining possible risk scenarios (unwanted events);
- Evaluating risks and assigning ratings (classification);
- Recording the risk analysis in a risk register;
- Managing risks according to their classification (prioritising for action);
- Identifying and implementing control measures (through the application of the Hierarchy of Controls) to ensure that risks are managed to levels that are as low as is reasonably practicable (ALARP);
- Developing action plans for reducing risk levels (where possible);
- Verifying the completion of actions;
- Re-evaluating the risks and classifications as appropriate; and
- Reviewing and updating the risk register.

7.1 Baseline Risk Assessments

Prior to site establishment, the client must conduct a detailed Baseline Risk Assessment identifying foreseeable hazards and risk scenarios associated with the contractor's scope of work on the project site(s) as required by Construction Regulations of 2014, regulation 5(1)(a). Details concerning proposed control measures must be included. The risk assessment process must be facilitated by a competent person who has been appointed in writing and must involve the participation of the contractor's site management representatives, supervisory personnel and technical experts (as required). An attendance register must be completed and retained for reference purpose. The Baseline Risk Assessment must be reviewed and approved by the Project Health and Safety Manager and Project Construction Manager.

When carrying out a Baseline Risk Assessment or a Task-Based Risk Assessment (refer to Section 6.2), Hazard (Energy) Types must be specified in accordance with the categorisation detailed in Table 6-1. Risk scenarios must be described indicating the manner in which a person may come into contact with, or be exposed to, a specific hazard.

An initial risk rating must be assigned to each risk scenario without taking any control measures into consideration. Control measures for managing the risks to levels that are as low as is reasonably practicable must then be identified for implementation on the project, and a residual risk rating must be assigned to each risk scenario taking the identified control measures into consideration.

Ratings must be assigned qualitatively using TCP consequence and likelihood scales and descriptors (i.e. TCP 5x5 qualitative risk matrix). Refer to Tables 6-2, 6-3 and 6-4.

Table 7-1: Hazard (Energy) Types

A Risk Register comprised of all significant risks (i.e. Risks rated as major or catastrophic) identified for the project will be compiled using the information contained in the project Baseline Risk Assessment as well as the contractor's Baseline Risk Assessment. Key control measures for managing each of these risks will be specified in the register.

For the significant risks in particular, action plans will be developed for reducing the risk levels (where possible).

The project Risk Register will be reviewed and, if necessary, updated:

- On a quarterly basis during construction;

- When changes are made to a design and / or the construction scope, schedule, methods, etc. That result in a change to the risk profile; and
- Following an incident.

The contractor must ensure that the hazards, risk scenarios and control measures identified in the contractor's Baseline and Task-Based Risk Assessments are taken into consideration when developing, implementing and maintaining the various elements of the contractor's health and safety management system for the project (e.g. Competence, training and awareness requirements).

All persons potentially affected must be made aware of the hazards, risk scenarios and control measures identified in the contractor's risk assessments. This must be done through training, Toolbox Talks, and Daily Safe Task Instructions (refer to Sections 10 and 11).

7.2 Task-Based Risk Assessments

The contractor must carry out detailed project-specific Task-Based Risk Assessments which must be reviewed and approved by the Client's Project Health and Safety Manager and Contract Manager prior to the commencement of any work.

The risk assessment process must be facilitated by a competent person who has been appointed in writing in terms CR 9 sub regulation (1). The contractor's site management representatives, supervisory personnel, technical experts (as required) and workforce personnel directly involved with the task being examined must participate in the risk assessment process. An attendance register must be completed and retained.

Please Note: Under no circumstances may a Contractor Health and Safety Officer perform a risk assessment in isolation. The active participation of all persons referred to above is mandatory.

A Task-Based Risk Assessment must at least:

- Be accompanied by a Work Method Statement (describing in sufficient detail how the specific job or task is to be performed in a logical and sequential manner);
- Provide a breakdown of the job or task into specific steps;
- Identify the hazards and potential risk scenarios associated with each step;
- Include consideration of possible exposure to noise, heat, dust, fumes, vapours, gases, chemicals, radiation, vibration, ergonomic stressors, or any other occupational health hazard or stressor;
- Describe the control measures that will be implemented to ensure that the risks are managed to levels that are as low as is reasonably practicable; and
- Assign an initial risk rating (without taking any control measures into consideration) and a residual risk rating (taking the identified control measures into consideration) to each risk scenario.

A Task-Based Risk Assessment must be reviewed and, if necessary, updated:

- On an annual basis (as a minimum);
- When changes are made to the associated Work Method Statement; and
- Following an incident.

7.3 Pre-Task Hazard Assessments

A pre-task hazard assessment must be completed whenever a change is identified while carrying out an activity. Any deviation from what was discussed during the Daily Safe Task Instruction (prior to the activity commencing), or anything that was not discussed, constitutes a change.

Before carrying out the particular task that involves the identified change, a few minutes must be spent identifying the hazards and risks associated with that task as well as suitable control measures.

8. Legal and Other Requirements

The Contractor must comply with the requirements of all applicable legislation as well as Transnet and project-specific standards and procedures as amended from time to time.

The Contractor must compile and maintain a register of all legal and other requirements applicable to the work that will be carried out and / or services that will be provided. This register must be updated regularly to ensure that it remains relevant.

Applicable laws and standards must be appropriately communicated to all employees of the contractor (as well as the employees of any sub-contractors that may be appointed by the contractor) through training, Toolbox Talks, and Daily Safe Task Instructions (refer to Sections 10 and 11).

9. Objectives

In order to drive continual improvement, the contractor must set project-specific objectives, and must develop improvement action plans to achieve these objectives. The contractor's objectives must be aligned with the objectives set for the project as a whole as required by the Construction regulations of 2014, regulation 7.

Eliminating hazards, minimising risks, preventing incidents, injuries and illnesses, and ensuring legal compliance must be the primary considerations for setting objectives.

When setting objectives, consideration must be given to the following:

- Leading indicators such as inspection findings, audit findings, hazard reporting, and observations;
- Lagging indicators (i.e. Incidents including Near Hits);
- Leading practices and lessons learnt; and
- Injury frequency rates with due understanding that the goal is "no harm".

The objectives must be specific and measurable. The improvement action plans must specify the resources (both human and financial) required to achieve the objectives, the person's responsible, and realistic timeframes for completion. The contractor must ensure that adequate resources are allocated and that progress towards meeting the objectives is monitored regularly.

The objectives and associated improvement action plans must be documented and must be communicated to all contractor employees. Furthermore, to ensure that the objectives remain relevant, they must be reviewed on a quarterly basis and whenever significant change has taken place on the project (i.e. Changes to activities, scope of work, operating conditions, etc.).

Performance reviews must be carried out at quarterly intervals to assess and document performance against these personal or team objectives.

If a reward or incentive scheme is introduced, it must be designed in such a manner that health and safety performance is not compromised in order to maximise financial reward.

10. Resources, Accountabilities and Responsibilities

The Contractor must adequately allocate resources, responsibility and accountability to ensure the effective implementation, maintenance and continual improvement of the contractor's HEALTH AND SAFETY management system on the projects required by Construction regulation Of 2014, regulation 7(2)(c)

For each role that carries health and safety accountability and / or responsibilities (including legislative requirements), a role description detailing the accountability and / or responsibilities must be documented.

All appointments (i.e. the assignment of specific SHE responsibilities to individuals in accordance with legal or project requirements) must be done in writing. Documented proof of each appointment (i.e. a signed appointment letter) must be retained.

Contractor should not discharge any legal responsibilities to employees who are not legally appointed.

The contractor must comply with the requirements of all applicable legislation concerning health and safety related appointments and delegations for the project.

A Organogram specific to the project must be documented and maintained. All roles that carry SHE accountability and / or responsibilities must be included, and all individuals that carry health and safety appointments must be clearly identified.

The provision of dedicated professionals on the project must be appropriate for the nature and scale of the work to be carried out.

The contractor is solely responsible for carrying out the work under the contract whilst having the highest regard for the health and safety of all persons on the project site(s).

Health and safety is the responsibility of each and every individual on the project site(s), but in particular, it is the responsibility of the contractor's management team who must set the tone.

Visible commitment is essential to providing and maintaining a safe workplace. The contractor's managers and supervisors at all levels must demonstrate their commitment and support by adopting a risk management approach to all health and safety issues. These individuals must consistently take immediate and firm action to address violations of health and safety rules, and must actively participate in day to day activities with the objective of preventing harm.

The contractor's management representatives are responsible and accountable for health and safety performance on the project. Key responsibilities include the following:

- Preparing, implementing and maintaining a risk-based Health and Safety Management Plan specific to the work that will be carried out (refer to Section 4);
- Establishing, implementing and maintaining health and safety programmes and procedures to ensure that all work is carried out in compliance with the requirements of this specification, the contract, and all applicable legislation;
- Establishing, implementing and maintaining effective hazard identification and risk management processes and procedures to ensure that all reasonably foreseeable hazards are controlled in order to minimise risk (refer to Section 6);
- Providing the resources necessary to meet the requirements of this specification (refer to Section 9);

- Ensuring that all contractor employees have clearly defined responsibilities with regard to health and safety, and that these responsibilities are clearly communicated and understood (refer to Section 9);
- Establishing, implementing and maintaining a system for ongoing training and assessment of skills and competence (refer to Section 10);
- Establishing, implementing and maintaining procedures to ensure that only qualified and competent personnel are permitted to work on the project site(s) (refer to Section 10);
- Establishing, implementing and maintaining effective communication and consultative processes concerning health and safety for the duration of the contract (refer to Section 11);
- Maintaining operational control for the protection of all persons on the project site(s) as well as the public (refer to Section 13);
- Establishing, implementing and maintaining effective emergency preparedness and response procedures (refer to Section 14);
- Establishing, implementing and maintaining effective management of change processes and procedures (refer to Section 15);
- Establishing, implementing and maintaining effective incident reporting and investigation processes and procedures (refer to Section 18);
- Establishing, implementing and maintaining effective auditing and inspection processes and procedures (refer to Section 20); and
- Formally reviewing the contractor's Health and Safety Management System annually to ensure that the system continues to be effective in managing health and safety performance and meeting project requirements (refer to Section 21).

All costs associated with meeting these responsibilities shall be borne by the contractor.

Any cost associated with any work stoppage due to non-compliance with a health and safety requirement shall be for the contractor's account.

10.1 Contractor Construction Manager

The Contractor must appoint a competent Construction Manager who shall be responsible for the successful and safe completion of all work to be carried out by the contractor as required by the Construction regulations of 2014, regulation 8(1).

The contractor's Project Manager shall be responsible for:

- Ensuring that a Health and Safety Policy that clearly states the contractor's values and objectives for the effective management of health and safety on the project is in place and is communicated to all contractor and sub-contractor employees;
- Ensuring that all applicable legal and project health and safety requirements are identified and complied with at all times;
- Ensuring that effective hazard identification and risk management processes are established and implemented for all work to be carried out by the contractor;
- Participating in the Baseline Risk Assessment for the contractor's scope of work (prior to site establishment);

- Participating in (and approving) all Task-Based Risk Assessments conducted for the work to be carried out by the contractor;
- Driving the achievement of agreed health and safety objectives;
- Ensuring that the necessary resources are made available for the effective implementation of the contractor's Health and Safety Management Plan;
- Ensuring that all work is adequately and competently supervised;
- Ensuring that all contractor employees have clearly defined responsibilities with regard to health and safety (assigned in writing), and that these responsibilities are clearly communicated and understood;
- Ensuring as far as is reasonably practicable that each contractor and sub-contractor employee is competent to perform his role, and has received appropriate workplace health and safety training and instruction;
- Managing all appointed sub-contractors with regard to health and safety performance;
- Establishing and maintaining effective communication and consultative processes to ensure that all contractor and sub-contractor employees are kept up to date with regard to health and safety information (e.g. Incidents and lessons learnt, leading practices, hazards, risks and control measures, etc.) And that feedback is provided promptly regarding issues and / or concerns raised;
- Participating in the project's Visible Felt Leadership (VFL) programme;
- Chairing monthly Contractor Health and Safety Meetings and attending monthly Site Health and Safety Meetings;
- Implementing programmes that encourage continual improvement and providing recognition for suggestions made by contractor and sub-contractor employees;
- Implementing the contractor's Health and Safety Management Plan and associated Safe Work Procedures;
- Acting consistently and strictly against any contractor or sub-contractor employee who transgresses a health and safety rule or requirement;
- Ensuring that an effective management of change process is in place;
- Implementing, testing and maintaining an effective Emergency Response Plan for all contractor and sub-contractor activities, and ensuring that the plan is adequately resourced;
- Ensuring that workplace exposure of contractor and sub-contractor employees to hazardous substances or agents is measured and monitored to determine the effectiveness of controls and compliance with legal (and project) requirements;
- Ensuring that all incidents are reported without delay and are investigated thoroughly;
- Participating in investigations into significant incidents;
- Ensuring that accurate health and safety statistics are maintained, and that health and safety performance reports are compiled as required;
- Providing the necessary resources for regular health and safety audits and inspections to be conducted, and supporting the auditing process;
- Participating in health and safety audits, and carrying out workplace inspections;

- Ensuring that corrective actions (arising from incident investigations, audits, inspections, etc.) Are implemented, and that adequate resources are provided for this purpose; and
- Participating in an annual review of the contractor's Health and Safety Management System.

10.2 Contractor Health and Safety Officers

The contractor must appoint a full-time Health and Safety Officer for the duration of the contract who is registered with the SACPCMP (The South African Council for Project Construction Management Professions). The project site(s) (directly or through sub-contractors), must at least appoint two full-time Health and Safety Officers depending on the scope, complexity, budget and high risk activities involved, as required by the Construction regulations of 2014, regulation 7(2)(c).

The Health and Safety Officer must be on site when work commences at the start of the day and must remain on site until all activities for that day (including the activities of sub-contractors) have been completed. A Health and Safety Officer must be present during all shifts, so if work is carried out over more than one shift per day, the contractor must make provision for an additional Health and Safety Officer.

Each Contractor Health and Safety Officer shall be responsible for:

- Reviewing all applicable legal and project health and safety requirements and providing guidance to contractor and sub-contractor personnel (particularly the contractor's Project Manager) to help ensure compliance at all times;
- Assisting with the implementation of effective hazard identification and risk management processes for all work to be carried out by the contractor;
- Participating in the Baseline Risk Assessment for the contractor's scope of work (prior to site establishment) and ensuring that identified control measures are implemented;
- Participating in all Task-Based Risk Assessments conducted for the work to be carried out by the contractor and ensuring that identified control measures are implemented;
- Conducting contractor health and safety induction training for all contractor and sub-contractor personnel;
- Compiling and maintaining all health and safety related documents and records required of the contractor;
- Communicating relevant health and safety information to contractor and sub-contractor personnel (e.g. Incidents and lessons learnt, leading practices, hazards, risks and control measures, etc.);
- Carrying out Safety Observations and Coaching (one per day);
- Evaluating (on a daily basis) the content of the Daily Safe Task Instructions (DSTI's) conducted by the contractor's appointed supervisors, and attending at least one DSTI each day;
- Attending monthly Contractor and Site Health and Safety Meetings;
- Assisting with the implementation of the contractor's Health and Safety Management Plan and associated Safe Work Procedures;
- Carrying out Planned Task Observations on an ad hoc basis;
- Assisting with the implementation, testing and maintenance of an effective Emergency Response Plan for all contractor and sub-contractor activities;
- Responding to workplace incidents (as appropriate);

- Participating in incident investigations;
- Maintaining accurate health and safety statistics (for the contractor and all sub-contractors), and compiling health and safety performance reports as required;
- Auditing the health and safety management system and workplace activities of the contractor and each sub-contractor on a monthly basis to assess compliance with the project health and safety requirements; and
- Tracking and reporting on the implementation of corrective actions (arising from incident investigations, audits, inspections, etc.).

The contractor must ensure that each Health and Safety Officer is adequately equipped to enable him to perform his duties effectively. Each Health and Safety Officer must be provided with the following:

- A computer with access to all necessary systems, including access to e-mail and the internet;
- A mobile telephone on contract or with adequate pre-paid airtime; and
- A vehicle where required or instructed by a nominated project management representative (depending on the size and location of the project site(s)).

A Health and Safety Officer must over and above the SACPCMP registration as an Officer; be computer literate, fluent in English, and must have the following minimum qualifications, training and experience:

- At least 5 years' experience as a Health and Safety Officer on construction projects;
- SAMTRAC, NEBOSH or an equivalent training course with accredited health and safety service provider as a minimum qualification ;
- Experience and appropriate training with regard to implementing and maintaining a health and safety management system compliant with national legislation or an international standard;
- Experience and appropriate training with regard to construction related hazard identification and risk management processes;
- Competence, experience and relevant training with regard to incident investigation procedures and causation analysis;
- Health and safety auditing experience and training;
- A valid First Aid certificate of competency;
- Fire prevention and protection training; and
- A valid Driving Licence (light motor vehicle).
- Registered as a Health and Safety Officer or Health and Safety Manager with SACPCMP depending on the size of the project and on the risk.

Before placing a Health and Safety Officer on the project site(s), the contractor must forward a copy of the person's CV to the nominated project management representative or to the Programme Health and Safety manager for review and acceptance. A proposed candidate may be rejected should he not meet the experience and / or qualification requirements, or due to poor work performance on previous projects.

10.3 Contractor Supervisors

The contractor must ensure that all project and / or construction works are supervised at all times by an adequate number of qualified, competent and appointed supervisors who have experience

in the type of work being carried out as required by Construction regulations of 2014, regulation 8(7).

No work may be carried out without an appointed supervisor being physically present in the work area and daily safety task instruction.

Each Contractor Supervisor shall be responsible for:

- Ensuring that all work carried out under his supervision is done so in accordance with the requirements of all applicable legislation, rules, standards, specifications, plans and procedures;
- Participating in Baseline and Task-Based Risk Assessments;
- Ensuring that all employees under his supervision are made aware of the hazards, risk scenarios and control measures identified in relevant risk assessments;
- Ensuring that the control measures stipulated in all relevant risk assessments are in place and are implemented fully for all work carried out under his supervision;
- Ensuring that all employees under his supervision conduct pre-task hazard assessments when necessary;
- Driving the achievement of health and safety objectives set for his team;
- Ensuring that the necessary written appointments are in place for each employee under his supervision (e.g. First aider, mobile crane operator, etc.);
- Ensuring that all employees under his supervision attend all required training;
- Ensuring that no employee carries out any work that he is not competent to perform or has not been appointed to perform;
- Identifying training needs within his team;
- Carrying out Safety Observations and Coaching (one per day);
- Conducting a weekly Toolbox Talk with his team;
- Leading a Daily Safe Task Instruction discussion with his team;
- Attending Health and Safety Meetings as required;
- Maintaining a Health and Safety Management Information Notice Board in the work area for which he is responsible;
- Recording, on a daily basis, a description of the day's activities as well as a breakdown (by occupation) of the personnel on site under his supervision (e.g. 5 bricklayers, 2 carpenters, 3 welders, 22 general workers, and 1 supervisor);
- Ensuring that all Safe Work Procedures applicable to the work carried out under his supervision are adhered to and are fully implemented;
- Maintaining discipline and taking the necessary action whenever an employee under his supervision does not adhere to a rule or requirement;
- Carrying out Planned Task Observations (one per day);
- Ensuring that emergency response procedures are understood by all employees under his supervision and that these procedures are followed in the event of an emergency;

- Reporting all incidents immediately, participating in incident investigations, communicating the lessons learnt to all employees under his supervision, and implementing corrective actions where required; and
- Carrying out workplace health and safety inspections.

Each supervisor must accept these responsibilities in writing as part of his appointment.

Each supervisor must be equipped with a mobile telephone to ensure that effective communication can be maintained for the duration of the contract.

10.4 Health and Safety Representatives

The team of employees on site must have a health and safety representative deployed on the project site(s), a Health and Safety Representative must be elected and appointed. Taking into consideration the number of employees deployed, the geographical area in which the work is taking place, the different work disciplines, and the shift pattern (if applicable), the contractor must ensure that an adequate number of Health and Safety Representatives (at a minimum ratio of one Health and Safety Representative per 50 employees) are elected and appointed to effectively represent all site personnel as required by the OHS Act 85 of 1993, section 17 - 18.

Each Health and Safety Representative must attend an accredited training course for health and safety representatives. The cost of this training shall be for the contractor's account.

The contractor must make the necessary allowances for the Health and Safety Representatives to carry out their duties as specified in the applicable legislation.

The contractor must ensure that an appropriate sticker is affixed to the safety helmet of each Health and Safety Representative for identification purposes.

10.5 First Aiders

If 10 or more employees are deployed on the project site(s), at least one trained and competent First Aider must be in place and must be appointed. Taking into consideration the number of employees deployed, the geographical area in which the work is taking place, the different work disciplines, and the shift pattern (if applicable), the contractor must ensure that an adequate number of First Aiders (at a minimum ratio of one First Aider per 50 employees) are in place and have been appointed to administer first aid treatment should this be required.

First Aid training must be done through an accredited training institution. The cost of this training shall be for the contractor's account.

The contractor must ensure that an appropriate sticker is affixed to the safety helmet of each First Aider for identification purposes.

10.6 Duties of Client

As per the Construction regulations of 2014, regulation 5(1) – (8) a client must—

- Prepare a baseline risk assessment for an intended construction work project;
- Prepare a suitable, sufficiently documented and coherent site specific health and safety specification for the intended construction work based on the baseline risk assessment contemplated in paragraph
- Provide the designer with the health and safety specification contemplated in paragraph (b);
- Ensure that the designer takes the prepared health and safety specification into consideration during the design stage;
- Ensure that the designer carries out all responsibilities contemplated in CR regulation 6;
- Include the health and safety specification in the tender documents;
- Ensure that potential principal contractors submitting tenders have made adequate provision for the cost of health and safety measures;

- Ensure that the principal contractor to be appointed has the necessary competencies and resources to carry out the construction work safely;
- Take reasonable steps to ensure co-operation between all contractors appointed by the client to enable each of those contractors to comply with these Regulations;
- Ensure before any work commences on a site that every principal contractor is registered and in good standing with the compensation fund or with a licensed compensation insurer as contemplated in the Compensation for Occupational Injuries and Diseases Act, 1993 (Act No. 130 of 1993);
- Appoint every principal contractor in writing for the project or part thereof on the construction site;
- Discuss and negotiate with the principal contractor the contents of the principal contractor's health and safety plan contemplated in CR regulation 7(1), and must thereafter finally approve that plan for implementation;
- Ensure that a copy of the principal contractor's health and safety plan is available on request to an employee, inspector or contractor;
- Take reasonable steps to ensure that each contractor's health and safety plan contemplated in
- CR Regulation 7(1)(a) is implemented and maintained;
- Ensure that periodic health and safety audits and document verification are conducted at intervals mutually agreed upon between the principal contractor and any contractor, but at least once every 30 days;
- Ensure that a copy of the health and safety audit report contemplated in paragraph (o) is provided to the principal contractor within seven days after the audit;
- Stop any contractor from executing a construction activity which poses a threat to the ensure that a copy of the health and safety audit report contemplated in paragraph (o) is provided to the principal contractor within seven days after the audit;
- Stop any contractor from executing a construction activity which poses a threat to the health and safety of persons which is not in accordance with the client's health and safety specifications and the principal contractor's health and safety plan for the site;
- Where changes are brought about to the design or construction work, make sufficient health and safety information and appropriate resources available to the principal contractor to execute the work safely; and
- Ensure that the health and safety file contemplated in CR regulation 7(1) (b) is kept and maintained by the Principal contractor.

Where a client requires additional work to be performed as a result of a design change or an error in Construction due to the actions of the client, the client must ensure that sufficient safety information and appropriate additional resources are available to execute the required work safely.

Where a fatality or permanent disabling injury occurs on a construction site, the client must ensure that the contractor provides the provincial director with a report contemplated in section 24 of the Act, in accordance with regulations 8 and 9 of the General Administrative Regulations, 2013, and that the report includes the measures that the contractor intends to implement to ensure a safe construction site as far as is reasonably practicable.

Where more than one principal contractor is appointed as contemplated in sub-regulation CR 5(1) (k), the client must take reasonable steps to ensure co-operation between all principal contactors and Contractors in order to ensure compliance with these Regulations.

Where a construction work permit is required as contemplated in CR 3(1), the client must, without derogating from his or her health and safety responsibilities or liabilities, appoint

a competent person in writing as an agent to act as his or her representative, and where such an appointment is made the duties that are imposed by these Regulations upon a client, apply as far as reasonably practicable to the agent so appointed.

Where notification of construction work is required as contemplated in CR regulation 4(1), the client may, without derogating from his or her health and safety responsibilities or liabilities, appoint a competent person in writing as an agent to act as his or her representative, and where such an appointment is made the duties that are imposed by these Regulations upon a client, apply as far as reasonably practicable to the agent so appointed: Provided that, where the question arises as to whether an Agent is necessary, the decision of an inspector is decisive.

An agent contemplated in CR sub-regulations (5) and (6) must—
 Manage the health and safety on a construction project for the client; and
 Be registered with a statutory body approved by the Chief Inspector as qualified to perform the required functions;

When the chief inspector has approved a statutory body as contemplated in CR sub-regulation (7) (b), he or she must give notice of that approval in the Gazette.

10.7 Duties of the Designer

As per the Construction regulations of 2014, regulation 6(1) – (2) a designer must –

- Ensure that the applicable safety standards incorporated into these Regulations under section 44 of the Act are compiled within the design;
- Take into consideration the health and safety specification submitted by the client;
- Before the contract is put out to tender, make available in a report to the client—
- All relevant health and safety information about the design of the relevant structure that may affect the pricing of the construction work;
- The geotechnical-science aspects, where appropriate; and
- The loading that the structure is designed to withstand;
- Inform the client in writing of any known or anticipated dangers or hazards relating to the construction work, and make available all relevant information required for the safe execution of the work upon being designed or when the design is subsequently altered;
- When modifying the design or substituting materials; take into account the hazards relating to any subsequent maintenance of the relevant structure and must make provision in the design for that work to be performed to minimize the risk;
- When mandated by the client to do so, carry out the necessary inspections at appropriate stages to verify that the construction of the relevant structure is carried out in accordance with his design: Provided that if the designer is not so mandated, the client's appointed agent in this regard is responsible to carry out such inspections;
- When mandated stop any contractor from executing any construction work which is not in accordance with the relevant design's health and safety aspects: Provided that if the designer is not so mandated, the client's appointed agent in that regard must stop that contractor from executing that construction work;
- When mandated in his or her final inspection of the completed structure in accordance with the National Building Regulations, include the health and safety aspects of the structure as far as reasonably practicable, declare the structure safe for use, and issue a completion certificate to the client and a copy thereof to the contractor; and
- During the design stage, take cognisance of ergonomic design principles in order to minimize ergonomic related hazards in all phases of the life cycle of a structure.

The designer of temporary works must ensure that -

- All temporary works are adequately designed so that it will be capable of supporting all anticipated vertical and lateral loads that may be applied;
- The designs of temporary works are done with close reference to the structural;
- The designs of temporary works are done with close reference to the structural design drawings issued by the contractor, and in the event of any uncertainty consult the contractor;
- All drawings and calculations pertaining to the design of temporary works are kept at the office of the temporary works designer and are made available on request by an inspector; and
- The loads caused by the temporary works and any imposed loads are clearly indicated in the design.

10.8 Duties of Principal Contractor

As per the Construction regulations of 2014, regulation 7(1) – (8) a Principal Contractor and Contractor must

- Provide and demonstrate to the client a suitable, sufficiently documented and coherent site specific health and safety plan, based on the client's documented health and safety specifications contemplated in CR 5(1)(b), which plan must be applied from the date of commencement of and for the duration of the construction work and which must be reviewed and updated by the principal contractor as work progresses;
- Open and keep on site a health and safety file, which must include all documentation required in terms of the Act and these Regulations, which must be made available on request to an inspector, the client, the client's agent or a contractor; and
- On appointing any other contractor, in order to ensure compliance with the provisions of the Act-
- Provide contractors who are tendering to perform construction work for the principal contractor, with the relevant sections of the health and safety specifications contemplated in CR regulation 5(1)(b) pertaining to the construction work which has to be performed;
- Ensure that potential contractors submitting tenders have made sufficient provision for health and safety measures during the construction process;
- Ensure that no contractor is appointed to perform construction work unless the principal contractor is reasonably satisfied that the contractor that he or she intends to appoint, has the necessary competencies and resources to perform the construction work safely;
- Ensure prior to work commencing on the site that every contractor is registered and in good standing with the compensation fund or with a licensed compensation insurer as contemplated in the Compensation for Occupational Injuries and Diseases Act, 1993;
- Appoint each contractor in writing for the part of the project on the construction site
- Ensure that a copy of his or her health and safety plan contemplated in paragraph (a),
- As well as the contractor's health and safety plan contemplated in CR 7 sub-regulation (2)(a), is available on request to an employee, an inspector, a contractor, the client or the client's agent;
- Hand over a consolidated health and safety file to the client upon completion of the construction work and must, in addition to the documentation referred to in CR 7 sub-regulation (2)(b), include a record of all drawings, designs, materials used and other similar information concerning the completed structure;
- In addition to the documentation required in the health and safety file in terms of paragraph (c)(v) and CR 7 sub-regulation (2)(b), include and make available a comprehensive and updated list of all the contractors on site accountable to the principal contractor, the agreements between the parties and the type of work being

principal contractor, the agreements between the parties and the type of work being done; and

- Ensure that all his or her employees have a valid medical certificate of fitness specific to the Construction work to be performed and issued by an occupational health practitioner in the form of Annexure 3.

10.9 Duties of Contractor

A contractor must -

- Prior to performing any construction work provide and demonstrate to the principal contractor a suitable and sufficiently documented health and safety plan, based on the relevant sections of the client's health and safety specification) and provided by the principal contractor), which plan must be applied from the date of commencement of and for the duration of the construction work and which must be reviewed and updated by the contractor as work progresses;
- Open and keep on site a health and safety file, which must include all documentation required and must be made available on request to an inspector, the client, the client's agent or the principal contractor;
- Before appointing another contractor to perform construction work be reasonably satisfied that the contractor that he or she intends to appoint has the necessary competencies and resources to perform the construction work safely;
- Co-operate with the principal contractor as far as is necessary to enable each of them to comply with the provisions of the Act; and
- As far as is reasonably practicable, promptly provide the principal contractor with any information which might affect the health and safety of any person at work carrying out construction work on the site, any person who might be affected by the work of such a person at work, or which might justify a review of the health and safety plan.

Where a contractor appoints another contractor to perform construction work, the duties that apply to the principal contractor apply to the contractor as if he or she were the principal contractor.

A contractor must take reasonable steps to ensure co-operation between all contractors appointed by the principal contractor to enable each of those contractors to comply with these Regulations.

No contractor may allow or permit any employee or person to enter any site, unless that employee or person has undergone health and safety induction training pertaining to the hazards prevalent on the site at the time of entry.

A contractor must ensure that all visitors to a construction site undergo health and safety induction training pertaining to the hazards prevalent on the site and must ensure that such visitors have the necessary personal protective equipment.

A contractor must at all times keep on his or her construction site records of the health and safety induction training and such records must be made available on request to an inspector, the client, the client's agent or the principal contractor;

A contractor must ensure that all his or her employees have a valid medical certificate of fitness specific to the construction work to be performed and issued by an occupational health practitioner in the form of Annexure 3.

10.10 Management and supervision of Construction work

A principal contractor must in writing appoint one full-time competent person as the construction manager with the duty of managing all the construction work on a single site, including the duty of ensuring occupational health and safety compliance, and in the absence of the construction manager an alternate must be appointed by the principal contractor.

A principal contractor must upon having considered the size of the project, in writing appoint one or more assistant construction managers for different sections thereof: Provided that the designation of any such person does not relieve the construction manager of any personal accountability for failing in his or her management duties in terms of this regulation.

Where the construction manager has not appointed assistant construction managers as in the opinion of an inspector, a sufficient number of such assistant construction managers have not been appointed, that inspector must direct the construction manager in writing to appoint the number of assistant construction managers indicated by the inspector,

No construction manager appointed may manage any construction work on or in any construction site other than the site in respect of which he or she has been appointed.

A contractor must, after consultation with the client and having considered the size of the project, the degree of danger likely to be encountered or the accumulation of hazards or risks on the site, appoint a full-time or part-time construction health and safety officer in writing to assist in the control of all health and safety related aspects on the site: Provided that, where the question arises as to whether a construction health and safety officer is necessary, the decision of an inspector is decisive.

No contractor may appoint a construction health and safety officer to assist in the control of health and safety related aspects on the site unless he or she is reasonably satisfied that the construction health and safety officer that he or she intends to appoint is registered with a statutory body approved by the Chief Inspector and has necessary competencies and resources to assist the contractor

A construction manager must in writing appoint construction supervisors responsible for construction activities and ensuring occupational health and safety compliance on the construction site.

A contractor must, upon having considered the size of the project, in writing appoint one or more competent employees for different sections thereof to assist the construction supervisor and every such employee has, to the extent clearly defined by the contractor in the letter of appointment, the same duties as the construction supervisor: Provided that the designation of any such employee does not relieve the construction supervisor of any personal accountability for failing in his or her supervisory duties in terms of this regulation.

No construction supervisor appointed under may supervise any construction work on or in any construction site other than the site in respect of which he or she has been appointed: Provided that if a sufficient number of competent employees have been appropriately designated on all the relevant construction sites, the appointed construction supervisor may supervise more than one site.

10.11 Construction Health and Safety Agent

A Construction Health and Safety Agent, based on their experience, knowledge and capabilities, as prescribed in the registration requirements for the Construction Health

and Safety Agent. A person will obtain registration once they have submitted the required documentation and met the registration criteria in full.

Construction Health and Safety Agent an applicant must provide proof of:

- Recognized and appropriate health and safety qualifications
- Relevant experience in the health and safety industry, with specific detail on construction experience
- Knowledge, skill and experience by attending and passing a professional interview
- Registration letter with SACPCMP

A Construction Health and Safety Agent is required to comply with the Continuing Professional Development (CPD) Policy Framework. A Construction Health and Safety Agent shall be expected to demonstrate detailed knowledge of health and safety requirements at all levels, with the capability to design, compile, implement and manage the health and safety requirements for a construction project from Initiation and Briefing to Project Close-out. A Construction Health and Safety Agent shall also be required to show ability to mentor, coach and guide Construction Health and Safety Managers and Construction Health and Safety Officers.

Construction project health and safety management systems.

A Construction Health and Safety Agent is expected to be experienced and knowledgeable in:

- Identifying and developing an appropriate health and safety legal framework for a construction project
- Principles of cause and effect analysis and its application to hazard identification and risk management on a construction project
- Identifying leading construction health and safety practice and applying such to a construction project
- Construction project health and safety risk profiling
- Designing and developing a construction project health and safety management system
- Construction project health and safety policy and standards
- Design risk management

10.12 Operational legal appointment letters

The contractor must ensure other legal appointment letter are compiled and be submitted with the Contractor compliance plan, below is some appointment required as per the legislation, the appointment letters varies based on the project;

- OHSA Sec 16(2)
- Sec 17,18,19 SHE Representative
- GSR 3(4) First Aider
- GAR 9(2) Incident investigator
- GMR 2(1) Supervisor of machinery
- GMR 2(7) Assistant Supervisor of machinery
- CR 4(1)(c) Principal Contractor
- CR 8(1) Construction Manager
- CR 8(2) Assistant Construction Manager
- CR 8(7) Construction Supervisor
- CR 8(8) Assistant Supervisor of construction work
- CR 8(5) Construction Health and Safety Officer
- CR 9(1) Construction Risk Assessor

- CR 10(1)(a),(b) Fall protection plan
- Developer
- CR 10(2)(d) Inspector of fall arrest system
- CR 14(2) Scaffolding Supervisor
- DMR 17(2),18 Inspector of lifting machinery
- CR17(8) Material hoist Inspector
- CR 19(2)(g)(i) Explosive powered tool issuer
- CR 23(1)(k) Construction vehicle and mobile plant Inspector
- CR 24(d) Temporary Electrical Installation Controller
- CR 24(e) Temporary Electrical Installation Inspector
- CR 28(a) Stacking and storage Supervisor
- CR 29(h) Fire extinguisher inspector
- EMR 8(8) Appointment for electrical installation in hazardous location- Master Electrician (Inspector)
- EIR 9 Installation Electrician appointment

11. Safety Agents in Project Stages

The safety agent, must be involved in all stages of project management and take charge of all the health and safety related matters.

11.1 Stage 1 – Project Initiation and Briefing

The deliverables at this stage shall include agreeing client requirements and preferences, assessing user needs and options, appointment of necessary consultants in establishing project brief, objections, priorities, constraints, assumptions and strategies in consultation with client.

Standard Services:

- Demonstrate the Construction Health and Safety Agent competency and resource;
- Assist in developing a clear construction project health and safety brief;
- Attend the construction project initiation meetings;
- Conclude the terms of the agreement with the client;
- Advise on the necessary surveys, analyses, tests and site or other investigations where such information will be required for the next stage of the project;
- Advise the client on the adequacy of health and safety competency and resources of the other consultants
- Identify construction project health and safety risk profile
- Provide necessary information within the agreed scope of the construction project to the other consultants;
- Define the Construction Health and Safety Agent scope of work and services;

11.2 Stage 2 – Concept and Feasibility

Finalisation of the project concept and feasibility.

Standard Services:

- Agree the documentation programme with the principal consultant and other consultants
- Attend design and consultants meetings;
- Review and evaluate design concepts and advise on construction project health and safety in conjunction with the other consultants;

- Review, update and agree the construction project health and safety risk profile and prepare the construction health and safety policy for the construction project;
- Advise on preliminary cost estimates/budgets for construction project health and safety
- Prepare draft construction project baseline risk assessment;
- Assist the client and principal consultant in the procurement of the necessary and appropriate specialists, including a clear definition of their roles, responsibilities and liabilities;
- Advise the client on the adequacy of the health and safety competency and resources of the appropriate specialists;
- Assess and approve the appropriate specialists health and safety plans;
- Monitor the implementation of the appropriate specialists health and safety plans, including periodic audits;
- Prepare the draft construction project health and safety specification;
- Agree the format and procedures for health, safety and hygiene construction project control
- Advise and agree with the other consultants regarding their construction project health and safety requirements and related design risk management responsibilities;
- Liaise, co-operate and provide necessary information to the client/principal consultant and the other consultants;

Construction Health and Safety Agent Deliverables

- Updated construction project health and safety risk profile;
- Agreed construction project health and safety policy for the project;
- Draft construction project baseline risk assessment;
- Draft construction project health and safety specification;
- Record of appropriate specialists health and safety competency and resource assessments;
- Schedule of required surveys, tests and other investigations and related reports;
- Record of construction project health and safety risk communication;
- Design risk management process;
- Preliminary cost estimates/budgets for construction project health and safety;
- Approved specialists health and safety plans;
- Specialists health and safety audit reports and records;

11.3 Stage 3 – Design Development

Manage, coordinate and integrate the detail design development process within the project scope, time, cost and quality parameters.

Standard Services

- Review the documentation programme with the principal consultant and the other consultants
- Attend design and consultants meetings;
- Finalise the construction project health and safety risk profile;
- Advise designers of their health and safety legal liabilities and responsibilities for constructability, maintainability and operation ability of the structure;
- Manage, co-ordinate, integrate and record the design risk management process with the other consultants in a sequence to suit the documentation programme;
- Monitor the integration of health and safety aspects for constructability, maintainability and operation ability of the structure during the design process and finalise the construction project baseline risk assessment;

- Identify and implement precautions necessary for construction project health and safety control and update the construction project tender health and safety specifications;
- Agree on a format for the health and safety file;
- Assess and approve necessary construction project health and safety plans for early works;
- Monitor the implementation of necessary construction health and safety plans, including periodic audits for early works;
- Assist the cost consultant with detailed information for initial construction project health and safety cost estimates/budgets;
- Liaise, co-operate and provide necessary construction project health and safety information to the client, principal consultant and the other consultants;
- Construction Health and Safety Agent Deliverables;
- Final construction project health and safety risk profile
- Record of construction project health and safety risk communication;
- Final construction project health and safety baseline risk assessment;
- Updated draft construction project health and safety specification;
- Design risk management records;
- Schedule of precautions necessary for construction project health, safety and hygiene control;
- Approved early works health and safety plans;
- Early works audit reports and records;
- Initial schedule of construction project health and safety cost estimates/budgets;
- Template for health and safety file.

11.4 Stage 4 - Tender Documentation and Procurement

The process of establishing and implementing procurement strategies and procedures, including the preparation of necessary documentation for effective and timeous execution of the project.

Standard Services

- Attend design and consultants meetings;
- Assist in developing a clear construction project health and safety procurement process;
- Finalise construction project tender health and safety specifications and integrate with procurement documentation;
- Provide and record construction project health, safety, hygiene and design risk information to the principal consultant and other consultants;
- Prepare construction project health and safety documentation for submission to authorities;
- Participate in construction project tender clarification meetings;
- Assist with the evaluation of tenders and verify the contractors competencies, knowledge and resources to carry out the construction works in a safe and healthy manner;
- Assist the cost consultant in the finalisation of the construction project health and safety cost estimate/budget;
- Assist with the preparation of contract documentation for signature;
- Prepare construction project health and safety mobilisation and access plans for the construction work;
- Assess samples, mock-ups and products for construction project, structural maintainability and operability health and safety compliance.

Construction Health and Safety Agent Deliverables

- Final construction project tender health and safety specifications;

- Records of construction project health and safety procurement process;
- Construction project health and safety tender evaluation and records;
- Finalised schedule of construction project health and safety cost estimate/budget;
- Construction project health and safety contract documentation;
- Construction project health and safety mobilisation and access plans;
- Design risk management records;
- Record of construction project health and safety risk;
- Construction project health and safety documentation for authorities;
- Evaluation schedule of samples/mock-ups and products.

11.5 Stage 5 - Construction Documentation and Management

The management and administration of the construction contracts and processes, including the preparation and coordination of the necessary documentation to facilitate effective execution of the works

Standard Services

- Assess, discuss, negotiate and approve the contractor(s) construction project health and safety plans;
- Submit necessary construction health and safety documentation to authorities and facilitate permits that may be required to commence the construction work;
- Attend site handover meetings and lead construction project health and safety mobilisation and access plans;
- Attend regular site, technical and progress meetings;
- Prepare revised construction project health and safety risk profile, specifications and cost estimates/budgets where there is scope of work changes;
- Monitor the implementation of the construction project health and safety plans in accordance with the construction project health and safety specification and further scope of work changes and recommend stop work orders where necessary;
- Monitor design risk management;
- Perform incident and accident investigations where necessary;
- Audit compliance with the construction project health and safety plans and brief the project management team and contractor(s) following site audits;
- Conduct construction health and safety management system audits;
- Facilitate construction health and safety system and plans reviews for continual improvement;
- Monitor the compilation of the construction project health and safety file by the contractor(s)
- Prepare and maintain the consolidated health and safety file;
- Prepare the structure commissioning health and safety plans.

Construction Health and Safety Agent Deliverables

- Approved contractor(s) construction project health and safety plans, including all construction health and safety appointments;
- Permits to commence construction work;
- Record of meetings, including all construction health and safety matters to be actioned;

- Record of revised changes to the construction project health and safety risk profiles;
- Record of revised changes to the construction project health and safety specifications;
- Record of revised changes and commissioning of the construction project health and safety plans;
- Record of revised construction project health and safety cost estimate/budget;
- Records of design risk management;
- Record of construction project health and safety audit reports;
- Record of contractor(s) construction health and safety performance;
- Record of construction project health and safety work stoppage reports;
- Record of incident and accident investigations and corrective actions;
- Record of interactions with the Compensation Commissioner or similar;
- Record of construction health and safety system and plans reviews;
- Record of construction project health and safety risk communication;
- Interim health and safety file;
- Structure commissioning health and safety plans.

11.6 Stage 6 - Project Close - Out

The process of managing and administering the project close out, including preparation and co – ordination of the necessary documentation to facilitate the effective operation of the project.

Standard Services

- Review, discuss and approve the health and safety file with the contractor(s) and manage the construction project health and safety during the defects liability period;
- Cancel all construction project health and safety legal appointments;
- Prepare the health and safety operations and maintenance report;
- Prepare the consolidated construction project health and safety close - out report;
- Construction Health and Safety Agent Deliverables;
- Record of audits during the defects liability period;
- Record of construction health and safety risk communication;
- Report on approved health and safety file;
- Health and safety operations and maintenance report;
- Consolidated construction project health and safety close-out report;

11.7 Additional Related Services

- Provide advice to the Client on health and safety competence and resources of up to [number] proposed designers prior to arrangements being made for design work to begin.
- Prepare [number] additional copies of the health and safety file.
- Prepare [number] copies of abstracts of the health and safety file for delivery to tenants by the Client/Owner's (The contents of the abstracts to be determined in consultation with the Client/Owner's legal advisors).
- Seek the co - operation of and co – operate with anyone else involved in a construction project at an adjoining site so far as necessary to enable them to perform their duties under the Construction Regulations.
- Facilitate co – operation and co – ordination in relation to duty holders on adjoining construction sites as it may affect the project; ensuring that suitable arrangements are made and implemented for the co – ordination of health and safety measures during planning and preparation for the construction phase.

- Keep a record of the health and safety file.
- Convert the health and safety files on other projects to match Client/ Owner's electronic format.
- Carry out necessary inspections at the appropriate stages to verify that the construction of the relevant structure is carried out in accordance with the design.
- To stop any contractor from executing any construction work that is not in accordance with the relevant design's health and safety aspects.
- Assist in the development of maintenance schedules for the Client/Owners completed structure.
- Inspect the structure on behalf of the Client/Owner once every six (6) months for the first two (2) years on completion of the structure and then yearly thereafter, to ensure the structure remains safe for continued use and records are kept of such in the structures health and safety file.

12. Competence, Training and Awareness

Each employee (including sub-contractor employees) must be suitably trained and competent, and must understand the health and safety hazards, risks and control measures associated with his work as required by the OHS Act 85 of 1993,(14)

The contractor must implement systems and procedures to ensure that:

- The necessary competencies required by employees are identified (by occupation), along with selection, placement and any training requirements;

Please Note: Specific competency profiles and selection criteria (fitness for work) must be developed for all roles where significant health or safety risk exists.

Please Note: A formal training needs analysis must be carried out based on the competency profiles and a training matrix must be developed for the project.

Roles requiring technical certification, registration or licensing are identified and documented, and these roles are filled only by suitably qualified personnel;

- Minimum core health and safety skills required by employees in leadership and supervisory roles are identified and suitable training is provided including hazard identification and risk assessment, incident investigation, and health and safety interactions (i.e. Observation and coaching techniques);
- Competency-based training is provided and it includes operational controls (procedures and work instructions), management of change, and emergency response;
- All employees hold and maintain the required competencies (including appropriate qualifications, certificates and licences) and are under competent supervision;
- A site-specific induction and orientation programme that highlights health and safety requirements, procedures, and significant hazards, risks and associated control measures is in place for all new employees and visitors (understanding must be assessed);
- Personnel are trained and / or briefed on new or amended standards, rules, safe work procedures, risk assessments, etc.;
- Refresher training is carried out as required (e.g. Re-induction following an absence from site);
- Records of education, qualifications, training, experience and competency assessments are maintained on site for all employees; and
- The effectiveness of training is reviewed and evaluated.

Prior to the commencement of any work, including mobilisation and site set-up activities, the contractor must provide, to the satisfaction of the nominated project management representative, current documentation verifying that the contractor's employees, as well as the employees of any appointed sub-contractors, are competent and have the necessary qualifications, certificates, licences, job skills, training and experience (as required by this specification and applicable legislation) to safely carry out the work that is to be performed.

The Contractor and sub-contractor must ensure that the following training takes place:

- health and safety induction training pertaining to the hazards prevalent on the site at the time of entry
- training for all persons required to erect, move or dismantle temporary works structures and instruction to perform those operations safely
- training of employees working from a fall risk position
- training to work or to be suspended on a platform which includes at least:
 - how to access and egress the suspended platform safely;
 - how to correctly operate the controls and safety devices of the equipment;
 - information on the dangers related to the misuse of safety devices; and
 - information on the procedures to be followed in the case of-
 - o an emergency;
 - o the malfunctioning of equipment; and
 - o the discovery of a suspected defect in the equipment;
 - o an instructions on the proper use of body harnesses.
- Training for all operators of construction vehicles and mobile plant.

A contractor must at all times keep on his or her construction site records of the health and safety induction training and such records must be made available on request to an inspector, the client, the client's agent or the principal contractor;

Please Note: Only certified copies of certificates, licences, etc. Will be accepted.

An Employee Profile (dossier) must be completed for each employee who will be performing work on site. All documentation pertaining to an employee's competence (i.e. certified copies of qualifications, certificates and licences as well as proof of job skills, training and experience) must be maintained in this dossier.

If it is determined through observation that an employee is not yet competent to carry out a particular task in a safe and capable manner, the employee will be required to cease work immediately and must either be reassigned or be retrained at the contractor's expense.

The contractor must provide proof that the training institutions and trainers that are used are appropriately registered with a governing authority (a trainer's registration certificate or registration number alone will not be adequate). The following must be made available for verification purposes:

- Proof of registration of the training institution including the training programmes that the institution is accredited to provide; and

- For each trainer, proof of competency and registration for the specific training programmes presented.

Foreign qualifications held by employees in health and safety critical roles must be verified against the requirements of local legislation.

12.1 Induction Training

Each employee must attend all mandatory Induction Training applicable to the project. No employee will be permitted to enter any project work site until he has attended this training. Each employee must carry proof that he has completed the induction training and may be removed from a site if such proof cannot be produced on request, this as required by the Construction regulations of 2014, regulation 7(5).

Furthermore, employees must attend (where applicable) Area-Specific Training pertaining to the particular hazards identified in the area(s) where the employees will be working. No employee will be permitted to enter a work area until he has attended the relevant area-specific training.

All visitors must receive a visitor induction briefing before entering any project work site. However, this induction does not permit a visitor to enter a site unescorted. Visitors must be accompanied at all times by an appropriately senior employee who has been fully inducted.

12.2 Specific Training and Competency Requirements

The following specific training and competency requirements must be complied with.

Please Note: An employee must be trained, assessed and found competent before he will be given authorisation to perform certain tasks or fill certain roles.

Table 11-1: Specific Training and Competency Requirements

Training	Applicable To
Health and Safety Induction	All employees
Safety Observations and Coaching (Safety Interactions)	All employees
Risk Assessment	All managers and supervisors
Incident Investigation	All managers and supervisors
Safety Leadership	All managers and supervisors
Legal Liability*	All managers and supervisors
Health and Safety Rep*	All elected Health and Safety Representatives
First Aid Levels 1, 2 and 3*	All nominated First Aiders
Fire Fighting (Fire Extinguisher Use)*	All employees
Working at Height*	All employees using a safety harness
Confined Spaces	All Confined Space Entry Officers and Standby Persons
Permit to Work	All Authorised Persons (i.e. Permit issuers) and all Applicants (i.e. Employees who will be applying for permits)
Isolation and Lockout	All Authorised Persons (i.e. Persons who authorise work that requires Isolation and Lockout), all Isolation Officers, and all Applicants (i.e. Persons who request permission to work on systems or equipment requiring Isolation and Lockout)

Training	Applicable To
Defensive Driving*	All drivers of light motor vehicles (for work purposes)
Gravel Road Driving*	All drivers of light motor vehicles driven on gravel roads (for work purposes)
Off Road Driving*	All drivers of four-wheel drive vehicles driven off road (for work purposes)
Mobile Equipment Site Licence	All mobile equipment operators

Training requirements marked with an * must be arranged through accredited external training institutions by the contractor. All other training will be provided by Transnet.

13. Communication, Participation and Consultation

The contractor must establish and maintain effective communication and consultative processes (allowing for a two-way dialogue) for the duration of the project to ensure that:

- All personnel are kept up to date with regard to health and safety matters (e.g. Hazards and risks, incidents and lessons learnt, leading practices, performance against objectives, etc.);
- General health and safety awareness levels are kept high;
- Prompt feedback is given to personnel with regard to health and safety issues or concerns that they raise; and
- Relevant, and often critical, health and safety related information (e.g. Design changes, instructions, reporting of hazardous conditions or situations, etc.) Is effectively disseminated.

This must be achieved as follows:

conditions.

13.1 Toolbox Talks

The contractor must prepare a Toolbox Talk on a weekly basis and must share it with all personnel for which the contractor is responsible (including all sub-contractors). Toolbox Talks must address health and safety issues that are relevant to the work performed on the project site(s) and must include information and / or knowledge sharing, lessons learnt from incidents that have occurred, information concerning specific hazards and / or risks and control measures to prevent injury, etc.

Attendance records must be kept and maintained in the contractor's health and safety file.

13.2 Daily Safe Task Instructions (DSTI's)

A Daily Safe Task Instruction (DSTI) is a pre-start discussion amongst the members of a work team, led by the appointed supervisor, aimed at anticipating hazards and potential risks associated with the activities planned for the day or shift, and ensuring that the necessary control measures are in place to prevent incidents.

At the start of each day or shift, prior to the start of any work, each appointed supervisor must inspect the work area for which he is responsible and ensure that it is safe. He must then conduct a DSTI with his work team specifically concerning the tasks that they will be performing during the course of the day or shift. The relevant Task-Based Risk Assessment for the activity must be used as the basis for the discussion. The correct work method must be reiterated and the identified hazards, risks and control measures must be

discussed with the team (each team member must be given the opportunity to contribute and participate in the discussion).

Any team member arriving late must first be taken through the information that was discussed (work method, hazards, risks and control measures) before being permitted to start working. If the work method changes after activities have already begun, the DSTI must be revisited and updated with the team, and the changes must be signed off by the relevant Contractor Health and Safety Officer.

Every member of the work team must sign the DSTI attendance register. The attendance records must be kept and maintained in the contractor's health and safety file.

The contractor's Health and Safety Officer must evaluate the content of the DSTI's daily to ensure that they are task-specific. Furthermore, the Health and Safety Officer must attend at least one DSTI per day prior to the start of work. The Health and Safety Officer may not lead the DSTI discussions, as this is the responsibility of the appointed supervisor.

13.3 Suggestions

All employees must be encouraged to submit suggestions to enhance health and safety management on the project site(s). A process must be in place for documenting, evaluating, implementing (as appropriate), archiving and recognising the improvement ideas.

13.4 Meetings

13.5.1 Contractor health and safety (OHS Act Section 19)

The contractor must schedule and consistently hold monthly health and safety meetings. These meetings must be chaired by the contractor's Project Manager and the following persons must be in attendance:

- Contractor and sub-contractor management representatives;
- Contractor and sub-contractor supervisors;
- Contractor and sub-contractor appointed Health and Safety (Employee) Representatives;
- Contractor and sub-contractor Health and Safety Officers; and
- The relevant Project Health and Safety Advisor.

The meeting must address the following as a minimum:

- New incidents for the period and corrective actions taken or to be taken;
- Implementation status of outstanding actions associated with previous incidents;
- SOC's, PTO's and DSTI's carried out for the period and action required to correct trends identified;
- Results of any audits, inspections (including H&S Rep inspections) or site visits carried out;
- A look ahead to ensure that appropriate health and safety planning and preparation is done for upcoming work;
- Risk Assessments, Safe Work Procedures, etc. That are outstanding or due for review (as well as the quality of these documents); and
- Any other health and safety related matter.

The contractor must compile minutes of each meeting and attendance records must be kept. These records must be maintained in the contractor's health and safety file.

13.5.2 Site Meetings

In addition to the Contractor Meetings, the Project will schedule monthly Site Meetings that the contractor must attend. These meetings will be chaired by the Contract Manager and the following persons must be in attendance:

- Contractor management representatives;
- Contractor Health and Safety Officers;
- Contractor Environmental Officer
- Contractor Quality Management
- The Project Health and Safety Manager;
- Project Health and Safety Advisors; and
- Client representatives (ad hoc).

The meeting will address the following as a minimum:

- Feedback from the contractor concerning health and safety performance for the period;
- New incidents for the period and corrective actions taken or to be taken;
- Implementation status of outstanding actions associated with previous incidents;
- SOC's, PTO's and DSTI's carried out for the period and action required to correct trends identified;
- Results of any audits, inspections or site visits carried out;
- A look ahead to ensure that appropriate health and safety planning and preparation Is done for upcoming work;
- Risk Assessments, Safe Work Procedures, etc. That are outstanding or due for review (as well as the quality of these documents); and
- Any other health and safety related matter.

13.5 Performance Boards

The contractor must provide and maintain a Performance Board to be approved by the nominated project management representative and to be positioned at the entrance to the contractor's site office area. This board must display the following information as a minimum:

- The contractor's logo;
- Current manpower (heads) on site;
- Man-hours worked for the current month and project to date;
- Lost Time Injury Frequency Rate (LTIFR);
- Dates of last injuries (FAI, MTI and LTI);
- Number of hours worked since the last recorded LTI; and
- Names and contact telephone numbers for the appointed Project Manager and the Health and Safety Officers.

13.6 Management Information Notice Boards

The contractor must provide, for each appointed supervisor, a portable Health and Safety Management Information Notice Board to be placed in the work area. The following information and documentation, as a minimum, must be posted on these boards:

- The relevant Method Statements, Risk Assessments and Safe Work Procedures for the work that is being performed that day;
- The DSTI for the day;
- The most recent Toolbox Talk;
- Where applicable, all required permits and permissions for the work that is being performed;

- Material Safety Data Sheets (MSDS's) for any chemical substances being used;
- The health and safety objectives for the work team;
- Details of the last incident involving the work team;
- The most recent weekly health and safety report (refer to Section 20);
- Emergency procedures;
- A site plan indicating evacuation routes and emergency assembly point locations;
- First Aider names and contact telephone numbers; and
- The appointed supervisor's contact details.

13.7 Involvement (Other)

The participation of all contractor (and sub-contractor) employees in activities that promote improvements in health and safety performance must be encouraged. In particular, this must include their appropriate involvement in:

- Hazard identification, risk analysis and determining control measures;
- Incident investigation; and
- Reviewing policy and objectives.

All regulations, instructions, signage, etc. Must be communicated in a language understood by all employees.

Health and safety personnel must be actively involved in planning activities so that they have the opportunity to highlight hazards and risks associated with upcoming work well in advance to ensure sufficient time to arrange and / or implement the necessary control measures.

14. Documentation and Document Control

The contractor must develop and maintain project-specific documentation required for the effective management of health and safety on the project.

All documents related to the contractor's health and safety management system must be effectively controlled.

The document control process must:

- Provide for the review, revision and version control of documents;
- Uniquely identify documents (as appropriate) to control their use and function;
- Require approval of the documents for adequacy prior to issue;
- Clearly identify changes and record the status of any revisions to documents; and
- Provide for the effective distribution of documents to, and where necessary the timely removal of obsolete documents from, all points of issue and use.

The contractor must establish a process for the systematic control of health and safety records and related data. Controls must be in place for the creation, receipt, secure storage, maintenance, accessing, use and disposal of such records and data.

Each record must be legible, identifiable and traceable, and must contain adequate information and data for its purpose.

The confidentiality and security of records and data must be maintained in a manner that is appropriate for the nature of the records and data, and in accordance with any applicable data or privacy protection legislation.

Personal information originating

From medical surveillance and occupational hygiene monitoring must be reported in a form that respects the privacy of the individual, but enables management to fulfil their

duty of care obligations to employees. The names of individuals must not be disclosed without their written authorisation.

Retention periods for all records (based on legal requirements and / or knowledge preservation considerations) must be established and documented in accordance with applicable legislation.

14.1 Contractor compliance File Requirements

The contractor must compile and maintain a file containing all necessary compliance related documentation. The client should provide construction work permit and to be kept on site at all times. The contents of the file will be audited by a Project SHE Advisor on a monthly basis.

Required documentation includes, but is not limited to, the following:

- Letter of Good Standing from the Workman's Compensation Commissioner (where applicable) must have dol stamp;
- Proof of Public Liability Insurance;
- Scope of Work under the contract;
- List of Contacts and their Telephone Numbers;
- Health and Safety Policy;
- SHE Management Plan;
- Legal Register;
- Organisational Chart for the project;
- Appointment Letters (appointment of the contracting company, and appointments for all persons with health and safety related responsibilities);
- Notifications to the relevant authorities that construction work is in progress;
- Baseline and Task-Based Risk Assessments;
- Health and Safety Objectives, and associated Improvement Action Plans;
- Safe Work Procedures, Work Instructions and Work Method Statements;
- Planned Task Observations;
- Fall Protection Plan (for work at height);
- A dossier (Equipment Profile) for each fuel-driven vehicle or machine;
- Inspection Registers, Forms and Checklists (e.g. For portable electrical tools, ladders, safety harnesses, light vehicles, mobile equipment, lifting equipment and lifting tackle, first aid boxes, fire extinguishers, etc.);
- PPE Issue Registers;
- Material Safety Data Sheets;
- Emergency Response Procedures;
- Incident Records;
- A dossier (Employee Profile) for each employee containing:
- A copy of the employee's Identity Document or Passport;
- Certificate of Fitness (Pre-Employment Medical Examination);
- Proof of Induction Training;
- Other Training Records;
- Copies of Qualification Certificates and / or Certificates of Competency; and
- Copies of Licences;
- Meeting Minutes;
- HEALTH AND SAFETY Performance Reports;
- Copies of Inspection and Audit Reports; and
- Daily Safe Task Instructions (DSTI's) and Toolbox Talks.

The contractor must ensure that an equivalent file is compiled and maintained by each appointed sub-contractor.

15. Notification of Construction Work

A contractor who intends to carry out any construction work other than work contemplated in CR regulation 3(1), must at least 7 days before that work is to be carried out notify the provincial director in writing in a form similar to Annexure 2 if the intended construction work will—

- include excavation work;
- include working at a height where there is risk of falling;
- include the demolition of a structure; or
- include the use of explosives to perform construction work.

A contractor who intends to carry out construction work that involves construction of a single storey dwelling for a client who is going to reside in such dwelling upon completion, must at least 7 days before that work is to be carried out notify the provincial director in writing in a form similar to Annexure 2 of the CR regulations.

16. Operational Control

For project operations and activities, the contractor shall implement and maintain:

- Operational controls, as applicable to the organization and its activities;
- The organization shall integrate those operational controls into its overall OH&S Management System;
- Controls related to purchased goods, equipment and services;
- Controls related to contractors and other visitors to the workplace;
- Documented procedures, to cover situations where their absence could lead to deviations from the OH&S policy and the objectives;
- Stipulated operating criteria where their absence could lead to deviations from the OH&S policy and objectives.

16.1 Project-Specific SHE Standards

For all site health and participation specific this will serve as a guideline

Project-specific SHE standards, incorporating leading practices, legal requirements, and client requirements will be developed and implemented to manage critical risks on the project.

The contractor must comply fully with the requirements of these standards.

The Safe Work Procedures required of the contractor must be aligned with the requirements of these standards.

16.2 Safe Work Procedures

Procedures to be developed and maintained on site

The contractor must develop, document and implement Safe Work Procedures for all activities involving significant health or safety risk. These procedures must detail the control measures required to effectively manage the health and safety risks associated with the work activities.

Each Safe Work Procedure must be consistent with the Task-Based Risk Assessment completed for the activity.

Every person engaged in an activity for which a Safe Work Procedure has been developed must receive suitable training on the procedure.

Furthermore, the contractor must develop, document, communicate and implement formal procedures, work instructions and / or programmes for the operation, maintenance, inspection and testing of all plant and equipment (including protective systems and devices) brought onto the project site(s).

16.3 Management Participation and involvement CR 8

16.4 Planned Task Observations

All contractor, management supervisors must perform Planned Task Observations (PTO's) to verify that the control measures that have been identified in Safe Work Procedures (and associated Risk Assessments) are being adhered to and are being properly implemented, and to provide guidance where deviations are noted.

Each supervisor must complete at least one PTO per day involving one or more employees in his work team.

When an unsafe act or condition is identified, the supervisor must coach the work team to correct the act or condition in line with the Safe Work Procedure.

Where valid changes to the work method are identified, the supervisor must ensure that the Safe Work Procedure and Risk Assessment are updated to reflect the current practice.

Project representatives will carry out PTO's on contractor employees on an ad hoc basis. Should deviations from the contractor's Safe Work Procedures be observed, the work may be stopped until these deviations are rectified.

16.5 General Rules of Conduct

All persons are required to conform to the following rules of conduct while on the site.

The following acts are prohibited:

- Engaging in practical jokes, horseplay, scuffling, wrestling, fighting, or gambling;
- Assault, intimidation, or abuse of any person;
- Insubordination towards any supervisor or manager;
- Refusing to carry out a reasonable and lawful instruction concerning health and safety;
- Entry into any restricted area (including barricaded areas), unless authorised to do so by the responsible person;
- Unauthorised use / operation of any equipment or machinery;
- Negligently, carelessly or wilfully causing damage to any property;
- Destroying or tampering with safety devices, signs, or signals;
- The use of water from fire hydrants or hose reels for any purpose other than extinguishing a fire;
- The wilful and unnecessary discharging of fire extinguishers;
- Refusing to give evidence or deliberately making false statements during incident investigations;
- Bringing alcohol, drugs, or any other intoxicating substance onto site;
- Bringing a firearm, ammunition, or any other offensive weapon onto site;
- Bringing animals onto site;
- Running, except in an emergency;
- The use of an ipod (or similar) whilst working on site;

- Sleeping on the job;
- Building fires on site, unless in a suitably constructed barbequing facility; and
- Pouring / pumping / flushing any substance (chemical / hydrocarbon / waste water) into a storm water drain, onto bare soil, or into any area where the substance is not effectively contained.

Any of the above actions may result in the temporary or permanent removal of the offending person(s) from site, as well as possible prosecution. The decision of the nominated project management representative shall be final and binding in respect of any dispute that may arise from the interpretation of these requirements.

Transnet will not get involved in contractor disciplinary rules and procedures. The contractor will simply be informed (with reasons) that the offending employee(s) will be denied access to the project site. Once the contractor has been informed, the employee(s) must be removed from the site immediately.

16.6 Site Access

The contractor may not hire any security services for the project site unless authorisation has been obtained in writing from a nominated project management representative.

16.6.1 Access Control

The contractor must comply with all access control, procedures and systems applicable to the project site.

Failure to comply with these requirements will be viewed as a serious safety breach and may result in the permanent removal of the individual(s) / contracting company from site or suspension without payment.

Access will be controlled as follows:

- The access will be strictly controlled and managed
- Contract period access – an access card valid for the full contract period will be issued to an individual once the following requirements have been met:
 - ♦ Completion of a pre-employment medical examination;
 - ♦ Completion of all required project induction training;
 - ♦ Completion of special training / licensing if applicable (e.g. Driving/operating Licence); and
 - ♦ Provision of proof of job / trade-specific qualifications, licences, training,

Experience and competency (as required).

Note: No access card will be issued unless proof of identification is provided (i.e. an identity document or a valid passport). For foreign labour, an access card will only be issued if a valid work visa is produced.

Note: A driving licence will not be accepted as proof of identification.

16.6.2 Trespassing

The contractor must ensure that no employee (including sub-contractor employees) trespasses on any land lying beyond the boundaries of the project site.

If instructed by a nominated project management representative to do so, the contractor must remove any employee who fails to comply with this requirement from the project.

The contractor's activities must be confined to the specified construction areas, and access to these areas may only be by means of specified routes.

All required barricading (fencing) must be erected and maintained by the contractor.

16.6.3 Visitors

Visitors (including reps and suppliers) must be advised in advance of the mandatory Personal Protective Equipment (PPE) requirements for the site, and must arrive with all of this PPE.

Upon arrival, all visitors must report to the Security Office where they must sign in.

All visitors must undergo a visitor induction briefing before entering the site.

A visitor access card will be issued to each visitor on conclusion of the induction briefing.

Whilst on site, visitors must be accompanied at all times by an appropriately senior employee who has been inducted fully. The visitor(s) must be met at the Security Office, and when the visit is over, must be escorted back to the Security Office.

When leaving the site, each visitor must return his or her visitor access card to the security personnel posted at the entrance / exit. A visitor will not be permitted to leave the site until he or she produces the access card that was issued.

Note: Visitors are not permitted to perform any work on site.

Note: Any request (typically made by a government official) to carry out a site inspection must be referred to the nominated project management representative. The contractor must not arrange any such inspection without prior approval from the nominated project management representative.

16.6.4 Alcohol, Drugs and Other Intoxicating Substances

The contractor must ensure that all personnel under his authority do not at any time enter the site or perform any work whilst under the influence of alcohol, a drug, or any other intoxicating substance.

Selling or possessing drugs, alcoholic beverages or any other intoxicating substance on the site is strictly prohibited.

A drugs and alcohol testing program will be implemented. Persons entering the site will be randomly tested. Any person who tests positive for alcohol or drug consumption will be subject to disciplinary action and shall be permanently removed from the site.

Any person have the opportunity to rather report that he/she is under the influence before accessing the project site – in these case the employee may only be send home for the day by the responsible project manager representative but will then be tested for the following five days (each day) on his return to the project site. If it is found that the same person is frequently reporting that he/she is under the influence before even accessing the project site. It shall be the responsibility of the nominated project management representative to take disciplinary action and remove such a person's form the project site.

Should the actions and / or demeanour of an employee suggest possible narcosis or drunkenness, the employee must be removed from the site. This may be done without testing.

Note: All personnel involved in an incident / accident must immediately be subjected to an alcohol test and a drug test as part of the investigation.

16.6.5 Firearms, Ammunition and Offensive Weapons

Firearms, ammunition, and offensive weapons of any kind are strictly prohibited. No person may enter /shall not be permitted to enter the site carrying any such item.

16.6.6 Vehicles

All vehicles brought onto site must meet the safety requirements stipulated in Section 14.6.

Each vehicle to be used on site must be inspected and approved by the nominated project management representative before a site access permit will be issued for the vehicle / equipment.

No vehicle shall be permitted to enter the site unless it is duly authorised. Access permits are vehicle-specific and may not be transferred between vehicles.

The contractor must allow any vehicle that is brought onto site (including privately owned vehicles) to be searched at any time while on the premises, or when entering or leaving the premises.

The contractor is solely responsible for the safety and security of all vehicles (including private vehicles) that he brings onto the site.

All road-going vehicles used by the contractor on the site must be roadworthy and registered with the relevant traffic authority.

A vehicle will not be permitted to enter the site in an un-roadworthy condition. Access will be denied if, for example:

- The vehicle has a defective exhaust system;
- A serious oil or fuel leak is evident;
- The vehicle has unsafe bodywork or is carrying an unsafe load;
- The vehicle is fitted with extraneous or non-standard equipment;
- Passengers are not seated properly;
- The vehicle is not fitted with a seat belt for each occupant; or
- The vehicle has any obvious mechanical defect;
- Pre-inspection requirements are not met.

Overloaded vehicles will not be permitted to enter the site.

The driver / operator of any vehicle / mobile equipment must carry a copy of his appointment with him at all times. Each driver / operator must:

- Comply with all site / project rules and regulations pertaining to traffic and the safe operation of vehicles / mobile equipment;
- Obey all road signs;
- Obey all instructions given by security or emergency services personnel;
- Remain within the boundaries of the site; and
- Ensure that the vehicle that he is operating is never overloaded, and that loads are always properly secured.

In the interest of safety, only the minimum number of vehicles required by the contractor to complete the work under the contract will be permitted to enter the site.

When not in operation, the contractor's vehicles / mobile equipment must be parked within the boundaries of his lay-down area or yard.

Parking is only permitted in designated parking areas.

All cars are parked on site at the owner's risk.

In the event of a vehicle accident on site, the driver(s) must report the incident immediately and must remain at the scene until a nominated project management

representative arrives, or until a nominated project management representative authorises him to leave (unless, of course, the driver requires medical attention).

16.7 Mobile Equipment and Light Vehicles

All Contractors must ensure all applicable legislation concerning mobile equipment and light vehicles are complied with at all times.

Each contractor must provide evidence to the nominated project management representative that all light vehicles and mobile equipment to be used on the project (including, but not limited to, lift and carry cranes (or mobi-lifts), mobile cranes, forklifts, mobile elevating work platforms (e.g. Cherry pickers), tractors, dozers, dump trucks, haul trucks, graders, excavators, loaders, back-actors, drill rigs, and road-going cars, light delivery vehicles, and trucks) comply with the requirements of all applicable legislation. This evidence must be provided prior to the equipment being brought onto the project site. The contractor remains responsible for meeting this requirement even if the equipment to be used is leased or provided by a sub-contractor (i.e. not owned directly by the contractor).

An Equipment Profile (dossier) must be compiled for each light vehicle and each item of mobile equipment to be used on the project site.

All mobile equipment and light vehicles (used for work purposes) must be subject to a risk assessment compiled. The assessment must:

- Involve operators and maintenance personnel who will use and work on the equipment; and
- Address all aspects of safe operation including handling, driver vision, brake failure, tyre blow out, and access and egress for operators and maintenance personnel.

Each light vehicle and each item of mobile equipment must be serviced and maintained as prescribed by the manufacturer of the vehicle or equipment.

No major repairs or services may be carried out on site.

No repairs may be carried out by a driver or operator. Only suitably qualified and competent persons may carry out repair work.

An appropriate pre-operation safety check based on a risk assessment must be carried out for each light vehicle or item of mobile equipment driven or operated for work purposes. For each vehicle or equipment type, an approved checklist must be in place (and must be used). The pre-operation check must include, but not be limited to, inspection and / or testing of the following safety critical features:

- Brakes (testing method must be provided);
- Wheels and tyres (including the spare);
- Lights and indicators;
- Steering;
- Seats and seat belts; and
- Windscreen and windows, including windscreen wipers and washers.

Should any critical feature be defective or damaged, the vehicle or equipment may not be operated until it has been fully repaired.

Supervisors must review the completed checklists on a daily basis to satisfy themselves that there are no major deficiencies that could place a driver or operator at risk.

No person may drive or operate any light vehicle or item of mobile equipment without authorisation.

All drivers and operators must be appointed in writing by the contractor's Project Manager.

No driver or operator may be appointed without proof that the individual has been trained, tested and found competent, or is currently licensed.

The appointment letter must specify the type of vehicle or equipment for which authorisation is being given and must clearly confirm that the driver or operator:

- Is 18 (eighteen) years of age or older;
- Has undergone a medical examination and has been declared fit for work by an occupational medical practitioner; and
- Has received suitable training and has been found competent, or is in possession of a valid driving licence issued by a state, provincial or civil authority that is applicable to the class of vehicle or equipment that is to be driven or operated.

The principal accountability for preventing accidents and incidents lies with the driver or operator of a light vehicle or item of mobile equipment, as he is in full control of any given situation at any given time. It must be stressed to each driver and each operator that safety is his prime responsibility – this must be clearly instructed and understood.

Drivers and operators must be empowered to stop driving or operating immediately should an unsafe condition arise, and refuse to drive or operate any light vehicle or item of mobile equipment that is defective and / or has any inoperative safety features. Similarly, a supervisor must never force a driver or operator to drive or operate a defective vehicle or item of equipment.

If a driver or operator does not adhere to the site rules and regulations, his appointment must be withdrawn and he must not be permitted to continue with his duties. If necessary, site access will be denied (either temporarily or permanently) to any driver or operator who is deemed to not be adhering to site requirements.

No person may drive or operate a light vehicle or item of mobile equipment if he suffers from a medical condition that places both him and those around him at risk of injury. A fit-for-work policy must be in place, incorporating clearly defined maximum levels of drugs (including prescribed medication) and alcohol permitted in the system of a driver or operator.

Daily alcohol testing and random drug testing must be carried out.

Supervisors must regularly check on the physical condition of drivers and operators during the course of a shift.

A system must be in place to manage driver fatigue.

No eating or drinking is permitted while driving or operating a light vehicle or item of mobile equipment.

A mobile phone, whether hands-free or not, may only be used by the driver or operator of a light vehicle or item of mobile equipment when the vehicle or equipment is stationary and in a safe location.

Behaviour-based observations and coaching must include the operation of light vehicles and mobile equipment.

A site-specific traffic management plan must be compiled and submitted to the nominated project management representative for approval. The plan must include, but not be limited to, the following:

- Segregation of pedestrians, light vehicles, and mobile equipment where possible (using barriers where feasible);
- Systems to control the movement of mobile equipment in areas accessible to pedestrians, the movement of mobile equipment into and out of workshops, and pedestrian and light vehicle movement around mobile equipment;
- Setting of appropriate speed limits for vehicle types, road surfaces and environmental conditions;
- Installation and maintenance of road traffic control signs;
- Right-of-way rules (including overtaking restrictions);
- Overtaking protocols;
- Clear communication protocols for interactions between all vehicles and equipment;
- Procedures for light vehicles and / or mobile equipment entering hazardous or restricted areas;
- Standards for safe following distances based on operational circumstances, environmental conditions and near sight (blind spot) limitations of mobile equipment;
- The minimum safe distance to be maintained between light vehicles and mobile equipment (i.e. 50 metres unless positive contact is made);
- Designated parking areas for mobile equipment and light vehicles, including parking associated with maintenance areas;
- Parking procedures (e.g. Safe parking distances, safe parking locations, requirements for reverse parking, etc.);
- Systems to control approaching, refuelling, parking, boarding and disembarking mobile equipment (a driver or operator must exit the cabin and must disembark the vehicle or equipment entirely when his direct involvement with maintenance or servicing is not required);
- Guidelines for abnormal road conditions (e.g. Heavy rain, fog, or high winds) providing "go / no go" criteria and contact details for the person(s) responsible for making the "go / no go" decisions;
- Truck loading and unloading procedures to avoid material or objects falling from the vehicle;
- Guidelines for wide or abnormal loads including offsite transport; and
- Systems to control mobile equipment use in the vicinity of overhead power lines.

The design and layout of the road system (including entrance and exit points, intersections and other potential points of interaction between pedestrians, light vehicles and mobile equipment) must be reviewed periodically.

A risk assessment must be carried out prior to any changes being made to traffic movements or road systems.

Designated walkways (both indoors and outdoors) must be provided for pedestrians, and pedestrians must make use of these walkways. Good lighting must be provided along all walkways, particularly at road junctions. Wherever possible, rigid barricading must be used to separate pedestrians from moving light vehicles and / or mobile equipment.

No pedestrians are permitted on haul roads (or as far as this can reasonably be achieved in situations where a haul road runs through an area occupied by a local community). All personnel must be transported to site and must be dropped off at a designated area.

Controls must be in place to ensure the safety of people working on roads, including those working on broken-down vehicles.

High visibility clothing must be worn by all persons at all times whilst on the project site. Speed limits and traffic rules must be reviewed regularly and must be rigorously enforced. Local traffic rules must be complied with at all times.

Pedestrians and cyclists must give way to light vehicles and / or mobile equipment except at pedestrian crossings.

All light vehicles and mobile equipment must give way to emergency vehicles. Pedestrians and light vehicle drivers must be made aware of the blind spots associated with mobile equipment.

The driver or operator of a light vehicle or item of mobile equipment must stop the vehicle or equipment and sound the horn before proceeding at blind corners, where his view of the path or intended path is obstructed, and when entering or leaving a building. Whenever a light vehicle or item of mobile equipment is stopped or parked, the handbrake (if applicable) must be applied.

Measures (such as chocking or the use of ditches or trenches) must be in place for the immobilisation of parked mobile equipment.

A parked light vehicle must be chocked in situations where the vehicle would roll forwards or backwards if placed in neutral with the handbrake disengaged.

No light vehicle or item of mobile equipment may be left unattended with the engine running or with a key in the ignition.

No light vehicle or item of mobile equipment may be parked so as to cause an obstruction to any roadway, passage or access way.

No light vehicle or item of mobile equipment may be parked within 50 metres of a loading or off-loading point.

Light vehicles and mobile equipment must be loaded safely. All loads must be secure and must be within the load limit of the vehicle or equipment. A load must be properly secured before the vehicle or equipment is set in motion. Adequate precautions must be taken for any overhanging load.

No unauthorised light vehicle or item of mobile equipment may enter a restricted area or building.

16.7.1 Light Vehicles

All Contractors must ensure that Light vehicles have the following minimum safety features:

- Fixed seats and suitable seat (safety) belts for all occupants (i.e. Driver and all passengers);
- Roll-over protection for all vehicles intended to be driven on dirt or steep roads;
- Cargo barriers and load restraints for all vehicles designed for carrying loads (other than passengers), or that are unable to have cargo separated from the occupant-carrying space of the vehicle; and
- An air bag on the driver's side, and where available as a manufacturer fitted item, a passenger's air bag;
- A Reverse Alarm.

All Contractors must ensure that Light vehicles that interact with mobile equipment are equipped or fitted with:

- Systems that enable positive communication with the equipment operators (e.g. A two-way radio);
- A high visibility flag (e.g. A whip flag or buggy whip);
- An amber flashing light (revolving or strobe);
- Reflective taping; and
- High visibility signage (i.e. Vehicle call numbers) facilitating easy and positive identification from a reasonable distance.

Note: Call number signs and reflective tape (magnetic or adhesive) must be applied to the front, back and sides of each vehicle.

All Contractors must ensure that Light vehicles carry:

- Emergency roadside triangles or beacons (three of either);
- Chock blocks for preventing uncontrolled movement of the vehicle when parked;
- A flashlight;
- A fire extinguisher (2.5kg DCP);
- A first aid kit; and
- Survival or emergency equipment (e.g. a vehicle recovery kit) suitable for the operating environment.

A change management process must accompany all vehicle modifications, including the attachment of any equipment. Examples of changes or modifications include, but are not limited to, any change or modification:

- Made to the overall structure or design of the vehicle body;
- Made to the original manufacturer-fitted type of tyres or wheels;
- Made to the suspension system of the vehicle;
- Made to the mechanical system of the vehicle;
- That may adversely alter the centre of gravity of the vehicle;
- That alters the load carrying capacity of the vehicle; and
- That may affect the ability of the vehicle to withstand a crash (e.g. the fitment of a "bull bar").

Vehicle selection must be based on a risk assessment where consideration is given to the tasks, the application, the environment, roll-over protection and the rating of sturdiness in the event of a crash.

All Contractors must have a formal inspection and preventative maintenance system in place to ensure that vehicles are maintained in a safe and roadworthy condition at all times and, as a minimum, are serviced in line with the vehicle manufacturer's service schedule.

Should any safety critical feature be defective or damaged, the vehicle must be withdrawn from service until it has been fully repaired. Inspection and maintenance must be undertaken on critical features such as:

- Wheels and tyres (including the spare);
- Steering, suspension and braking systems;
- Seats and seat belts;
- Lights, indicators and reflectors;
- Windscreen and windows, including windscreen wipers and washers;

- The vehicle structure itself; and
- Other safety-related items on the vehicle body, chassis or engine, including instrumentation.

Persons may only be transported in vehicles equipped with manufacturer fitted or approved seats and seat belts.

Seat belts must be worn by all occupants of a light vehicle (i.e. the driver and all passengers) at all times.

Only the driver and one passenger are permitted in the cab (front) of a light delivery vehicle.

No personnel may be transported in the load-bin of a light delivery vehicle, even if the vehicle is fitted with a canopy. Only tools and equipment may be transported in the load-bin. Furthermore, no persons may be transported in a trailer behind a vehicle.

A pre-operation vehicle safety check and familiarisation system must be in place and must be used by the driver. An approved checklist must be used. All vehicle faults that are recorded must be attended to immediately.

All Contractors must have systems in place to ensure that risks associated with vehicle journeys are managed and controlled. The systems must include, but not be limited to:

- Formulation of journey management plans prior to the commencement of new or changed travel activities;
- Identification and monitoring of the risks associated with the various routes, intersections, etc. In order to minimise the overall exposure;
- Assessment and communication of changed environmental and road conditions at the time of travel;
- Outlining of actions required in the event of an emergency (e.g. Collision or breakdown); and
- Provision to manage driver fatigue.

Light vehicle running lights (low-beam headlights) must be switched on at all times when the vehicle is in operation.

All Contractors must have a system in place to ensure that drivers receive adequate training to ensure that the vehicle intended to be operated or driven can be operated or driven safely. As a minimum, training must include:

- Behaviour-based defensive driving principles;
- Vehicle familiarisation, taking into account the handling dynamics of the vehicle, maximum number of passengers, load limits and various features;
- Loading and restraining principles where the vehicle to be operated is designed for carrying cargo loads;
- Education and awareness concerning driving and travel risks that may be encountered within the environment where the vehicle may be operated or driven, and the requirements pertaining to traffic rules and speed limits;
- Securing (locking) equipment to prevent unauthorised use;
- Emergency crash and breakdown procedures; and
- Basic mechanical principles, including how to change a tyre and perform an adequate pre-operation check.

A system must be in place to ensure that persons operating any equipment associated with a light vehicle (e.g. Vehicle-mounted cranes and winches) are suitably trained and competent.

16.7.2 Mobile Equipment

All Contractors must ensure that Mobile equipment have the following minimum safety specifications:

- Fixed seats and seat belts for all occupants;
- Adequate lighting, including headlights, tail, turn and brake lights, and an amber flashing light (revolving or strobe);
- An identified isolation and lockout point;
- Adequate walkways, railings, steps and grab handle combinations, and boarding facilities including an alternative path of disembarking in the event of an emergency;
- Collision-avoidance technology and / or procedures;
- A reversing alarm or warning device;
- Chock blocks for preventing uncontrolled movement of rubber-tyred equipment when parked;
- A horn;
- Effective windscreen wipers;
- Effective guarding on accessible moving parts;
- A speedometer (if the mobile equipment is capable of exceeding the lowest applicable speed limit);
- High visibility signage (i.e. Mobile equipment call numbers) facilitating easy and positive identification from a reasonable distance; and
- A security system to prevent unauthorised operation.

Mobile equipment must have the following minimum safety specifications, unless a risk assessment stipulates otherwise:

- Approved or certified roll-over protection;
- Fail-to-safe brakes;
- A fire detection and suppression system capable of being activated from both ground level and cabin level (for certain types of mobile equipment, a suitably sized fire extinguisher may be adequate);
- A non-handheld two-way radio or another form of communication;
- Falling object protection (a protective structure over the operator cabin);
- An enclosed and tight-sealing air-conditioned cabin with suitable protective glass; and
- A means of moving supplies and personal items into and out of the operator cabin that enables an operator to continuously maintain three points of contact while boarding and disembarking the equipment (e.g. A backpack or shoulder strap bag).

When purchasing or hiring equipment, the ergonomics of the cabin must be considered, specifically with regard to the seating, operator controls and retrofitted devices.

Fleet and control consistency must be considered in order to minimise the possibility of operator error when changing machines.

For all new (to site) and modified mobile equipment, a formal risk-based selection and acceptance process must be followed prior to the equipment being used on site.

Selection of equipment, and any modification, must be subject to a rigorous change management process.

An inspection and maintenance programme must be in place for all mobile equipment. A procedure and checklist system, including a brake functionality test, must be in place for pre-operation inspection by the operator. Registers must be maintained and audited, and must be kept on the machine.

Procedures must be in place to ensure that mobile equipment is only operated on sufficiently stable surfaces and on gradients that are within the limits of safe operation.

Seat belts must be used in all cases, by all occupants. Apart from the driver or operator, only an appointed flagman may be transported in mobile equipment (with the exception of buses) and **only if** the equipment is fitted with a passenger seat. No passengers are permitted on a lift and carry crane (or mobi-lift), mobile crane, forklift, mobile elevating work platform (e.g. A cherry picker), tractor, dozer, dump truck, grader, excavator, loader, back-actor, drill rig, or similar.

Risk assessments must be carried out as part of the planning process for mobile equipment operations and associated activities, and must consider the following:

- Maintenance activities;
- Risks associated with loading, unloading, towing and recovering mobile equipment; and
- The risk of fire.

Procedures must be in place for the safe isolation and lockout of mobile equipment.

Where two or more items of mobile equipment must be operated in proximity to each other, or where an item of mobile equipment must be operated in proximity to persons on foot, a risk assessment involving all persons who will be working in the area must be conducted prior to the work commencing. The risk assessment must be approved by the nominated project management representative. In such a work area:

- No item of mobile equipment may be driven to within 5 metres of another item of mobile equipment without the operator first making eye contact with, and signalling his intentions to, the other operator who must acknowledge that he understands and that it is safe to proceed.
- No person on foot may work or be positioned within 5 metres of an item of mobile equipment that is in operation. Before approaching mobile equipment on foot, a person must make eye contact with, and clearly signal his intentions to, the operator of the equipment. The operator must cease to operate the equipment, and must indicate that he understands and that it is safe to approach.

In certain circumstances (determined through risk assessment), mobile equipment may only move and operate with dedicated flagmen in place:

- Where flagmen are used, it must be ensured that the flagmen, mobile equipment operators, and all other personnel working in the vicinity of the mobile equipment, receive suitable training with regard to signals and signalling to ensure effective communication. The training must be formal and recorded, and competency must be tested.

- A flagman and the mobile equipment operator that he is directing must maintain eye contact. The flagman must never position himself where the equipment operator cannot see him.
- Should a mobile equipment operator lose sight of his flagman, he must stop his activities immediately until contact has been re-established.

A tyre management system must be in place to address issues including fire, heating, explosion, electrical contact, separations, maintenance, tyre changes, etc.

Site-specific induction must be carried out prior to a mobile equipment operator starting work on site. Area-specific induction must be carried out prior to an operator starting work in a new area on site.

Operators must report conditions and practices that do not conform to procedure.

16.7.3 Training and Licensing

No person may drive a light vehicle or operate an item of mobile equipment unless he has been trained, tested and found competent, or is currently licensed to drive or operate that specific vehicle or item of equipment.

The training must address hazards and risks assessed for:

- That vehicle; and
- The tasks for which it is to be used.
-

No person may be appointed to drive a light vehicle or operate an item of mobile equipment unless he is in possession of a valid medical certificate of fitness (issued by an occupational medical practitioner).

Each person required to drive a light vehicle or operate an item of mobile equipment on the project site must have a project-specific site licence or appointment to drive or operate that vehicle or item of equipment.

A system must be in place to ensure that the renewal of licences is based on an assessment of competency to drive and / or operate the vehicle or equipment. The frequency of assessment must either be annual, or derived from a risk assessment for each vehicle or equipment type.

No training of drivers or operators may be carried out on site unless authorised by a nominated project management representative.

Each person working on or visiting the project site must receive appropriate project-specific induction training concerning road safety and site vehicle hazards.

Driver must be in possession of valid certificate, licence and trained by an accredited service provider.

16.7.4 Tyre and Rim Safety

These requirements apply to tyres and wheels and safety with a rim diameter of 60cm (24 inches) or greater.

A Tyre Management Plan must be established and reviewed every twelve months.

Safe Work Procedures must be in place for all tyre maintenance and servicing activities and for tyre fire emergency response.

All persons who will be carrying out tyre maintenance and servicing work and / or responding (potentially) to tyre fire emergencies on site must be certified against the

requirements of job-specific competency standards for the project, which must address job-specific Safe Work Procedures.

No person may approach a light vehicle or item of mobile equipment within 24 hours of:

- The vehicle or equipment being struck by lightning;
- The vehicle or equipment making contact with high voltage electricity; or
- A tyre fire.

In the event of a tyre fire, an exclusion zone of 300 metres must be established and may only be accessed by emergency services personnel who are shielded while fighting the fire.

Restricted Work Zones must be established for tyre installation, removal and handling processes.

All tyre and rim handling equipment must have fall back prevention in place prior to anyone entering the Restricted Work Zone.

Tyres with split rhealth and safety must be deflated to zero and other tyres to a nominal pressure no greater than 5psi prior to removal of any retaining devices. In a dual assembly both tyres must be deflated.

Tyre inflation is subject to the following requirements:

- All tyre inflation must be carried out remotely;
- Where the risk of ejection of components exists, barricading must be in place;
- A tyre must not be left unattended during inflation; and
- Tyres that have run at less than 80% cold inflation pressure must not be re-inflated. Both tyres in a dual assembly must be dismantled and inspected.

No hot work (e.g. Welding or cutting) may be carried out on a rim (wheel) while the rim is fitted with a tyre – whether inflated or deflated.

A periodic testing and / or inspection regime must be in place for tyres, rhealth and safety (wheels), and assemblies.

All tyres and rhealth and safety (wheels) must be made unserviceable when deemed unfit for service or before being sent off site for disposal.

A tracking system must be in place to track the lifecycle of tyres and rhealth and safety (wheels).

16.7.5 Roads

Design, inspection and maintenance requirements must be in place for all roadways.

Every haul road must have two dedicated and clearly demarcated lanes so that vehicles travelling in opposite directions are safely separated (lane demarcation is not applicable to dirt roads).

Systems (such as safety berms) must be in place along roadways and around excavations, dump areas, etc. To prevent vehicles from leaving a roadway or entering a dangerous area.

A storm water management plan must be in place for the site and, in particular, for all roads. Extreme wet weather must be considered. Contractors must ensure that all roads are equipped with drainage system.

Roads with high risks activities and traffic interface shall be controlled by trained flagman

A dust control plan must be in place for the site and, in particular, for all roads. Where required, contractors must ensure that roads are wetted (using a water cart) at regular intervals and whenever instructed by a nominated project management representative. The over-watering of roads must be prevented.

No road may be closed without permission from a nominated project management representative.

Any large rocks in a roadway must be removed immediately. Any spillage in a roadway must be cleaned up immediately.

Ground pollution (e.g. Oil, diesel or hydraulic fluid spillages) must not, and will not, be tolerated. If substances are spilled on a road or any other portion of the site, the contaminated ground must be dug out and the resulting hole back-filled with clean material which must be suitably compacted. The contaminated soil must be disposed of as required by the applicable legislation.

16.8 Signs and Notices

The contractor must ensure that all required safety signs and notices are prominently displayed in accordance with the applicable legislation and good safety practice.

Signs and notices must be in English as well as any other language(s) commonly spoken on the project site.

All symbolic signs must comply with the applicable national standards.

No person may deface or damage any safety sign or notice. No person may remove or alter any safety sign or notice unless authorised to do so.

16.9 Machinery

The contractor must ensure that all plant and equipment brought onto the site is:

- Appropriate for the type of work to be performed
- Approved, inspected, tested, numbered and tagged (if appropriate) before being brought onto site
- Properly maintained in accordance with the manufacturer's recommendations; and
- Placed on a register and checked at least once per month or as required by the applicable legislation.

The contractor must supply, at his cost, all items of plant and equipment necessary to perform the work and must maintain all items in good working order.

Should any plant or equipment become inoperable for a period that is having or will have a significant impact on the work schedule, the contractor must, on instruction from the nominated project management representative, remove the out of service plant or equipment and replace it with similar fully operational plant or equipment at no additional cost.

No item of plant or equipment delivered to site for use on the contract may be removed from the site prior to the completion of the contract without approval in writing from the nominated project management representative.

Items of plant or equipment brought onto site by the contractor or his sub-contractors may be inspected by a nominated project management representative. Should the nominated project management representative determine that any item is inadequate, faulty, unsafe or in any other way unsuitable for the safe and satisfactory execution of the work for which it is intended, the contractor must, on instruction from the nominated

project management representative, immediately remove the item from the site and replace it with a safe and adequate substitute. In such a case, the contractor or his sub-contractor shall not be entitled to additional payments or deadline extensions in respect of any delay caused.

16.10 Barricading

All applicable legislation concerning barricading must be complied with at all times.

Each contractor required to erect barricading on the project site(s) must develop, document and implement Safe Work Procedures that are aligned with the requirements of this standard.

Barricading must be erected to:

- Prevent persons from making contact with an identified hazard;
- Provide warning of the existence of a hazard;
- Prevent unauthorised access (by people, vehicles and mobile equipment) into an area where a hazard exists or where a hazardous activity is being carried out;
- Define the boundaries of a hazardous location and / or restricted area; and
- Allow a work team to perform hazardous tasks without persons unfamiliar with the hazard(s) accessing the area.

Although not limited to these situations, barricading must be erected or installed:

- Around excavations (trenches, pits, etc.) (refer to the Excavation Standard);
- To protect openings and edges (to prevent persons from falling, all openings and edges associated with floors, stairs, and the open sides of buildings and structures during the course of construction must be protected by sturdy, rigid barriers capable of withstanding a force of at least 110 kilograms applied in any direction at any point) (refer to the Working at Heights Standard);
- To prevent access into areas where overhead work is in progress;
- To route vehicles safely through (or around) construction areas; and
- To protect members of the public who may be in the vicinity of a work or construction site (by preventing access).

In all cases, the erection of barricading must be a temporary measure. It must only remain in place until the hazard is eliminated or the potentially dangerous situation is rectified.

A barricade must present a sturdy physical barrier to entering an area. Therefore, plastic cones, post and chain systems, "danger tape" and "snow netting" will not be accepted as barricading and may only be used for the purposes of low risk demarcation.

For example, snow netting may be used for the demarcation of lay down areas.

Acceptable forms of barricading include:

- Hoarding panels (no less than one metre in height) that can be securely fastened together to form a fence line may be used. Hoarding panels may be constructed from a variety of materials (e.g. wooden board, steel sheeting, wire mesh on a steel frame, etc.)
- Wire mesh fencing (no less than one metre in height with sturdy posts spaced at intervals of no more than 3 metres) may be used in certain circumstances, e.g. Around excavations.
- Sturdy, rigid, and securely fixed (i.e. bolted, welded, clamped, etc.) Metal guard rails may be used, particularly for protecting openings, holes and edges associated with

floors, platforms, walkways, etc. The top rail must be positioned at a height of one metre above the working surface, and a mid-rail must be provided.

- Concrete Jersey barriers must be used for the routing of traffic and when work is being conducted in or alongside a roadway.

Regardless of the type of barricade used, the following requirements must be met:

- The installation, alteration and removal of barricades must be supervised by a competent person;
- The barricading must be uniformly and intelligently configured;
- The barricading must be stable, conspicuous and effective;
- The barricading must completely surround the work or hazardous area;
- General access requirements around the work or hazardous area (such as pedestrian walkways, operational access, or general thoroughfares) must be taken into consideration when erecting a barricade;
- The extent of the area that is barricaded must be kept to a minimum so as not to unnecessarily restrict access to other areas. If access routes to other areas are blocked by the barricade, alternative routes must be identified and signposted
- All barricaded areas must have properly designated points of entry and exit for persons and / or vehicles. Each pedestrian access point must be fitted with a self-closing gate. A sign indicating, "DESIGNATED ACCESS POINT – AUTHORISED PERSONNEL ONLY", must be fitted to each gate;
- Additional signage providing warning of specific hazards (e.g. falling objects, electricity, etc.) Including, "NO UNAUTHORISED ENTRY", must be attached to all gates and, where required, to the barricading itself. The signage must be visible from all angles and must be large enough to be read from a distance of 10 metres;
- Barricading must be clearly visible at all times (day and night). If necessary, flashing warning lights must be used;
- Tags must be attached to the barricading displaying the name and cell phone number of the person responsible for the barricade, and specifying the reason for the barricading and the date on which it is scheduled to be removed;
- Should a person require access to a barricaded area, authorisation must be obtained from the person responsible for the erection of the barricade. The hazards that are present and the Personal Protective Equipment that must be worn within the barricaded area must be communicated to the person seeking access;
- Each barricade must be listed in a register, and each must be inspected daily to ensure that it is still intact and that its positioning is still effective;
- All barricades must be properly maintained and repaired as required;
- When the work has been completed and the hazard has been eliminated, all barricading must be removed without delay. A barricade may not be left in place if no hazard exists;
- Before a barricade is removed (allowing general access), the area must be inspected by the person responsible for the work that was carried out, to ensure that the area is once again safe. If applicable, the person accepting the area back for general use shall do so on completion of his own safety inspection;
- Authorisation to remove (or modify) a barricade may only be granted by the person responsible for the erection of the barricade.

16.11 Excavations

All applicable legislation concerning excavation work must be complied with at all times.

Each contractor carrying out excavation work on the project site(s) must develop, document and implement Safe Work Procedures that are aligned with the requirements of this standard.

All excavation work must be properly planned. Site-specific conditions and hazards must be considered, including traffic, overhead and buried utilities, proximity to nearby structures, soil properties, presence of surface and / or ground water, position of the water table, and weather conditions.

Excavation work may only be carried out under the personal supervision of a competent Excavation Supervisor who has been appointed in writing.

Before any excavation work is carried out, a Permit to Work authorising the activities must be obtained.

Similarly, no person may enter an excavation unless a Permit to Work has been issued providing authorisation for specific tasks to be carried out within the excavation.

Before issuing a Permit to Work for excavation works, the Authorised Person (i.e. Permit issuer) must verify that:

- A detailed Risk Assessment has been conducted for the work to be performed;
- A Safe Work Procedure is in place; and
- No buried services are present in the area where the excavation works are to be carried out.

As a minimum, the Risk Assessment must consider hazards and risks associated with:

- A person being trapped or buried as a result of an excavation collapsing;
- A person being struck by an object falling into an excavation;
- A person falling into an excavation;
- A person being exposed to a hazardous atmosphere within an excavation (i.e. An oxygen deficiency, explosive or flammable gases, and / or harmful concentrations of a contaminant);
- Contact with belowground services; and
- Mobile equipment and / or light vehicle movement in proximity to an excavation.

On a plan (drawing) of the work area, the contractor must accurately indicate the position and dimensions of each intended excavation in order for it to be determined whether or not buried services would (or may) be encountered, such as electrical cabling, communications cabling, gas, fuel, potable water, fire water, effluent, sewage, or storm water pipelines.

In addition to a desk top review of existing drawings, a field survey must be carried out to verify the presence or absence of buried services. The positioning of all known belowground services must be accurately demarcated in the field before any excavation work commences.

Should there be any uncertainty, a pipe or cable locator must be used to determine if buried services are present, and if so, the positioning of the services.

If buried services are identified (or are suspected to be present) then the excavation plan must be altered if necessary to avoid these services. If the excavation plan cannot be altered then safe work methods (e.g. careful excavation by hand) must be specified and

measures (e.g. Isolation and lockout of the service) must be put in place to minimise risk to personnel and prevent damage to the service(s).

Machinery may not be used to excavate material lying within one metre of any belowground service (i.e. Cable or pipe).

Excavation work that is carried out must be limited to what is described in the Permit to Work. All controls, precautions and restrictions identified in the Permit to Work (and Risk Assessment) must be strictly observed and fully implemented. The Excavation Supervisor must discuss these controls, precautions and restrictions with all persons who will be carrying out the work.

All excavation work must be carried out by persons who have been trained and are competent to perform the work.

All personnel working in or near any excavation must wear high visibility protective clothing.

Unexpected structures (e.g. Tanks, brick work, concrete work, etc.) Or services (e.g. Cables, pipe lines, etc.) As well as unusual conditions (e.g. inconsistent materials, voids, etc.) That are encountered during excavation work must be reported immediately. All work must cease until the nominated project management representative provides authorisation to continue.

If an excavation is more than 1.2 metres deep and people have to enter it, then the sides of the excavation must be suitably battered, benched, or shored, unless a registered professional geo-technical engineer confirms in writing that there is no risk of the excavation collapsing (i.e. That the sides of the excavation are stable without battering, benching or shoring).

If the sides of an excavation are battered (sloped), then this must be done at an angle that is suitable for the given soil conditions (to be determined by a registered professional geo-technical engineer).

When it is not possible to batter (or bench) the sides of an excavation to a safe angle, then the sides of the excavation must be suitably shored. Shoring may only be installed, altered or removed under the personal supervision of a competent person using a predetermined safe method. Only approved shoring systems and equipment may be used. Shoring requirements must always be determined and designed by a competent person for the specific conditions encountered at the excavation site.

All material removed from an excavation (spoil) must be placed no closer than three times the depth of the excavation away from the edges of the excavation.

The profile of this spoil must be flattened out to prevent the material from being washed back into the excavation by rain water.

Scaling must be carried out on the sides of all excavations to remove loose material.

Protective shields or barriers must be erected (when required) between the sides of an excavation and the work area in order to protect employees from falling, rolling or slumping rock, soil, or materials.

Persons may not work on the faces (sides) of battered (sloped) or benched excavations at levels above other persons.

Tools, equipment and materials may not be placed within two metres of the edges of an excavation. Alternatively, a suitable retaining device may be used to prevent tools, equipment and materials from falling, rolling or sliding into an excavation.

No vehicle or item of mobile equipment is permitted near an edge of an excavation.

Mobile equipment may not operate in or near an excavation whilst persons are working within the excavation.

To ensure that adjacent structures (such as buildings, walls, or sidewalks) remain stable during excavation work, support systems such as shoring, bracing, or underpinning must be provided if required. Excavation below or near the base or footing of any foundation or retaining wall is prohibited unless:

- A support system (designed by a registered professional geo-technical or Structural engineer) is provided, such as underpinning; or
- A registered professional geo-technical engineer determines that the structure is far enough away from the excavation that no hazard exists.

To prevent persons and / or mobile equipment from accidentally falling into an excavation and to prevent unauthorised entry into an excavation, rigid barricading must be erected around every excavation that is deeper than 500mm. Warning signage must be prominently displayed and, if necessary, flashing warning lights must be used at night.

The barricading must remain in place for as long as the hazard (i.e. the excavation) exists. Sections of barricading around an excavation may only be removed (and then only temporarily) to enable excavation work to continue (refer to the Barricading Standard).

For each excavation more than 1.2 metres deep, safe means of access and egress (e.g. Ladders, steps or ramps) must be provided for persons working in the excavation. Safe entry and exit points must be located every 15 metres along the side(s) of an excavation (i.e. an exit point must not be more than 7.5 metres away from any person working in the excavation).

If a hazardous atmosphere exists within any excavation (i.e. an oxygen deficiency, the presence of explosive or flammable gases, and / or harmful concentrations of a contaminant) or if there is a possibility that a hazardous atmosphere may develop, then the excavation must be declared a confined space. Furthermore, an excavation must be considered a confined space if any risk of entrapment or engulfment exists. If an excavation is declared a confined space then all precautions and requirements pertaining to confined spaces must be implemented and complied with (refer to the Confined Spaces Standard).

Internal combustion engines may not be used in or near the edge of an excavation unless the exhaust emissions are ducted away or suitable mechanical (forced air) ventilation is used to maintain a safe atmosphere within the excavation.

Any water and / or sludge present within an excavation must be removed completely before any work commences in the excavation.

Using ditches, dykes, sumps and pumps, or other suitable means, surface water must be prevented from entering an excavation and areas lying adjacent to an excavation must be adequately drained.

If equipment is used to prevent water from entering an excavation or to prevent water accumulation within an excavation, then the equipment must be monitored by a competent person to ensure that it remains operational and effective.

Suitable lighting must be provided in and around any excavation in which work must be carried out at night.

A high standard of housekeeping must be maintained in and around all excavations.

Tools that are not in use, and materials that are no longer required, must be removed from an excavation to prevent these items from causing injury or being lost (buried).

A register of all excavations must be compiled and maintained.

A competent person (i.e. an appointed Excavation Supervisor) must inspect each excavation as well as the areas around it:

- At the start of each day (or shift) before work commences within the excavation;
- After any alteration is made to the excavation or shoring;
- After rainfall;
- After any blasting activity carried out in the vicinity of the excavation; and
- After any event that may have affected the strength or stability of the excavation or the shoring.

An excavation must be inspected for collapses, signs of instability, failures or signs of overloading of protective systems and equipment, hazardous atmospheres, water accumulation, and any other hazardous condition that may arise.

The sides of an excavation as well as the surface of the ground around the excavation must be carefully inspected for signs of instability including fissures (cracks), slumping, and bulging. Shoring must be carefully inspected for signs of overloading (e.g. Distortion).

If a hazardous condition is identified, no person may enter the excavation until suitable corrective actions have been taken and / or suitable controls have been put in place to either eliminate the hazard or reduce the risks to acceptable levels.

A record of each inspection (including date, time, findings, and signature of the Excavation Supervisor who carried out the inspection) must be captured in the excavations register. Each inspection record must include a declaration as to whether the excavation is safe to work in or not.

All excavations must be monitored closely throughout each work day (or shift) by the Excavation Supervisor.

If an excavation has been declared a confined space, a safety observer (who will be able to initiate emergency response procedures if required and identify the location of any trapped or buried persons in the event of a collapse) must be stationed at ground level outside of the excavation whenever work is being carried out in the excavation.

If a hazardous condition is identified while work is being carried out in an excavation, then all persons in the excavation must be evacuated to safety without delay.

Under no circumstances may a person work alone in an excavation that is more than 1.2 metres deep without at least one other person being present in the immediate vicinity of where the work is being carried out.

Excavations must be backfilled as soon as possible, and the material used (usually the original material) must be properly compacted.

Where belowground services are present, the material used to backfill an excavation must be such that the services will not be damaged.

A layer of a material that is dissimilar to the general backfill material must be placed immediately above any buried service.

An excavated area must be restored to its original condition if at all possible.

Use of Explosives

All excavation work must be carried out without the use of explosives.

Explosives may not be brought onto the site or be used without written authorisation from the nominated project management representative.

If blasting operations are unavoidable, the contractor must:

- Provide a justification and obtain approval from the nominated project management representative;
- Strictly observe the provisions of all applicable legislation; and
- Carry out a detailed risk assessment covering the transportation, handling, storage and use of the explosives.

No explosives or detonators may be stored on site.

Detonators and other explosives must never be carried in the same box.

16.12 Cranes and Lifting Equipment

All applicable legislation concerning cranes and lifting equipment must be complied with at all times.

Each contractor carrying out lifting operations on the project site(s) must develop, document and implement Safe Work Procedures that are aligned with the requirements of this standard.

16.12.1 Design, Manufacturing and Safety Features

Before any crane or hoist is operated on the project premises (i.e. New to site), it must be formally accepted (authorised) by the nominated project management representative. The acceptance process must be based on an inspection and risk assessment, and must take the crane's or hoist's safety features and cabin ergonomics (if applicable) into account. The same process must be followed before any crane or hoist is returned to service following any modification or repair.

Note: An Equipment Profile (dossier) must be compiled for each crane.

As a minimum, the design and manufacturing of each crane or hoist used on the project premises must comply with the requirements of the relevant ISO standard. In countries where the requirements of a national standard are more stringent than the requirements of the relevant ISO standard, the national standard must apply.

The Safe Working Load (SWL) must be clearly indicated on each crane, hoist, and item of lifting equipment.

If the safe working load (rated capacity) of a crane varies with the conditions of use (i.e. varies with the angle of the boom and the boom length) then the manufacturer's load chart(s) indicating the crane's rated capacity at various boom lengths and angles must be available in the crane cabin. If the crane has a single load chart, it must be displayed in a

position visible to the crane operator. If the crane has numerous load charts, they must be easily accessible to the operator.

For each crane or hoist, the manufacturer's operating manual must be available to the operator.

The load chart(s) and operating manual for a crane or hoist must be in a language understood by the operator.

All lifting hooks must be fitted with a safety latch to prevent the load from accidentally detaching.

Each crane or hoist must be fitted with a load cell (with the mass of the load displayed in the visual range of the operator) and a load limiting device to prevent the crane or hoist from being operated outside of its safe working limits.

Where practicable, each crane must be equipped with an upper hoist limit switch (or anti two-block device) to prevent the hook block from colliding with the drum, and a lower hoist limit switch to prevent the rope on the drum from unwinding completely. These systems must provide both a visual and an audible alarm to the operator.

Under no circumstances may any limit switch or warning device be bypassed, disconnected, or adjusted in order to lift a load higher (or to lower a load lower) than the respective switches allow. Limit switches MAY NOT be adjusted to stop the hoist at a particular height under normal operating conditions – these are safety devices, and as such, should not be used as operating tools.

Under no circumstances may a load limiting device be bypassed or disconnected in order to lift a load that exceeds the rated capacity of the crane. Load limiting devices MAY NOT be used to "measure" or "test" the mass of a load – these are safety devices, and as such, should not be used as operating tools.

Each overhead travelling crane (including cranes operated using a manual chain drive) must be fitted with an audible travel alarm or an equivalent warning device.

Anti-collision devices must be fitted to prevent motorised overhead travelling cranes from colliding with each other (where two or more cranes run on the same track) and from colliding with the track end stops or other structures.

For a vehicle-mounted crane, the operator control station must be located in a position protected from swinging loads and from the crane jib.

A fall protection system must be provided for the assembly, dismantling, operation, maintenance and inspection of any crane where falling from height is identified as a hazard.

Each crane should be fitted with a stability monitoring device to prevent it from toppling over.

Only items of lifting equipment (tackle) that have been designed and manufactured with adequate factors of safety may be used on site. The following minimum factors of safety (with respect to the Safe Working Load) must be met:

- Ten (10) for natural-fibre ropes;
- Six (6) for synthetic-fibre ropes or woven webbing;
- Six (6) for steel-wire ropes;

- Five (5) for steel chains; and
- Four (4) for high-tensile or alloy steel chains.

Note: An excavator may not be used to lift a load unless all of the requirements of this standard (as would apply to a crane) have been met, and authorisation has been granted by the relevant Project Manager and Health and Safety Manager.

16.12.2 Planning and Risk Assessment

For each critical lift that must be carried out on site, a documented and detailed lift plan and risk assessment must be prepared to address all associated hazards.

Only suitably qualified, competent and experienced persons (lift planners) may evaluate critical lifts and prepare lift plans.

The lifting supervisor, crane operators, riggers and spotters responsible for carrying out a critical lift must have input into the lift plan and risk assessment and must be consulted before these documents are finalised.

All lift planners, lifting supervisors, crane operators, riggers and spotters (safety observers) must be appointed in writing.

No critical lift may commence until the lift plan and risk assessment have been authorised by the nominated project management representative and a Permit to Work has been issued.

Critical lifts include:

- All multiple (including dual) crane lifts;
- Lifts where the operational arcs of two or more cranes can overlap;
- Lifts over operating facilities where this may endanger personnel;
- Lifts over or adjacent to power lines;
- Any lift carried out in close proximity to equipment or a vessel containing a flammable or toxic substance;
- Lifts where the centre of gravity of the load could change;
- Any lift where the total weight on the hook exceeds 20 tonnes;
- Lifts near the rated capacity of the crane (i.e. Exceeding 85% of the rated capacity at the working radius);
- Any lift when the wind speed (including gusting) exceeds 30 kilometres per hour;
- Lifts involving a man basket (safety cage);
- Lifts to and from water;
- Lifts requiring specialised equipment or involving complicated lifting or rigging configurations;
- Lifts requiring non-standard rigging or slinging techniques;
- Lifts involving the simultaneous use of more than one hoist on the same crane;
- and
- Any other lift deemed to be critical by the nominated project management representative, or assessed as critical during a risk assessment.

The lift plan for a critical lift must include:

- General Information – crane manufacturer, crane model, items to be lifted, and reason for lift;
- Lift Data – load weight, lifting block and hook weight, hoist rope weight, rigging weight, total weight, height of lift, radius of lift, surface area of load, and centre of gravity of load;

- Rigging Data – sling material (chain, wire rope, or synthetic), sling diameter, sling length, sling configuration, sling capacity, hook type, shackle size and capacity;
- Lift Computation – boom length, jib length, radius of lift, crane capacity as configured, size of outrigger footplates, and wind speed;
- Proximity to Power Lines and Process Areas – mobile cranes working in proximity to energised power lines must operate under a Permit to Work, which must define exclusion zones and spotter duties;
- Local Hazards and Controls – including the route for the crane, ground stability, proximity of people or equipment, and agreed communication method; and
- Diagrams (sketches) – a rigging diagram, and a crane set-up diagram illustrating the positioning of the crane(s) in relation to surrounding structures and the initial and final positions of the load (including crane boom movement).

Lifts that are not subject to detailed lift plans (i.e. Lifts that are not considered critical) must nevertheless be subject to a risk assessment, and be properly planned and executed. The use of a crane-suspended man basket (safety cage) may only be considered when all other avenues to safely perform the work (e.g. Scaffolding, mobile elevating work platform, etc.) Have been exhausted (refer to the Working at Heights Standard).

Cranes used to lift or suspend personnel must be approved as suitable for this purpose. If a crane must be operated in proximity to energised overhead power lines (or any other exposed electrical conductors) then minimum clearance distances (specified by the electrical power utility or the nominated project management representative) must be observed. Whenever possible, power lines must be de-energised and isolated while lifting operations are carried out (refer to the Electrical Safety Standard).

16.12.3 Operation

At the start of every day or shift, the operator of a crane or hoist must carry out a pre-operation safety check using a prescribed checklist.

The specific requirements of the pre-operation safety check (and associated checklist) must be based on:

- A risk assessment that addresses all aspects of safe operation of the crane or hoist; and
- The inspection recommendations of the manufacturer.

As a minimum, the pre-operation safety check must include:

- A thorough visual inspection of all wire ropes, chains, hooks and safety latches, hook blocks, sheaves, hydraulic hoses, electrical cables, and the general condition of the crane or hoist;
- Checks to confirm the serviceability of the operating controls;
- Tests to confirm the correct operation of all limit switches, emergency shutdowns, load indicators, alarms and other safety devices; and
- A thorough visual inspection of all lifting equipment (tackle) to be used.

The operator must:

- Check for any loose or missing parts;
- Make sure that the wire rope (or chain) of the hoist is properly seated in its drum and sheave grooves without any slack or overlapping;
- Operate each control to make sure it functions properly, releases immediately, and does not stick. Each control must be labelled to indicate its function;



- Listen for any unusual mechanical noises and look for any jerky movements while operating the crane and / or hoist several feet in each direction that it travels;
- Check the functionality of the upper and lower hoist limit switches (if applicable) by slowly raising and then lowering the block to trip the respective switches;
- Check all hooks. Hooks must not be cracked, stretched, bent or twisted. Each hook must have a safety latch that automatically closes the throat of the hook. If the latch is bent, has a broken spring, or is otherwise damaged, it must be repaired before use. Hooks must rotate freely in the block assembly without any “grinding” felt or heard;
- Check the wire rope by lowering the block to its lowest level and looking for the following signs of damage:
 - ♦ Reduced rope diameter. This may indicate that the rope has been stretched, has lost its inner core support, or has worn outside wires;
 - ♦ Broken wire strands (any number);
 - ♦ Kinked, crushed, cut, or “bird caged” wiring, or wiring with heat damage.
- Check all chains for damage including wear at contact points, cracks, or distorted links (bent, twisted or stretched). All mechanical coupling links must be inspected to ensure that the linking pins are secure and in good condition. The capacity rating of each chain must be adequate for the load and the attachment method;
- Check the condition and capacity of wire rope and synthetic web slings. Capacity ratings must be legible on the manufacturer’s label. The capacity of the sling being used must be adequate for the load and the attachment method. A sling must be replaced immediately if it is excessively worn.

The operator must report any fault, defect or damage to his supervisor immediately. A crane or hoist must not be operated if any safety device is out of order or defective, or if any rope, chain, hook or other component is worn or damaged.

Completed checklists must be made available (on request) for inspection by the nominated project management representative. Wherever possible, these checklists must be kept with the crane or hoist.

All lifting operations must be supervised by suitably qualified, competent and experienced supervisors.

An effective method of communication between the crane operator and those assisting with the lift must be in place. This must be documented and approved by the nominated project management representative.

Documented Safe Work Procedures must be in place to ensure the following:

- Access into an area where lifting operations are being carried out must be restricted. Such an area (i.e. where there is a risk of a load falling and striking a person) must be barricaded and only authorised persons may enter (i.e. those directly involved with the lifting operations). Warning signage must be conspicuously displayed;
- Where a load is being moved from one location to another (i.e. The lifting operations are not being carried out in a discrete area that can be barricaded), measures must be taken to ensure that all persons in the path of the suspended load are made aware of the approaching hazard and that they move, and remain, well clear of it. All persons potentially affected must be given warning before the load is lifted;
- A lift must be directed and controlled by a single person (a suitably qualified, competent and experienced rigger);

- Dedicated spotters must be in place during lifting operations to observe and provide warning (if necessary) to prevent incidents and ensure that safety protocols are adhered to;
- Before commencing with a lift, it must be verified that the load being lifted is both within the rated capacity of the crane (or hoist) and lifting equipment and within the limits set out in the lift plan and / or risk assessment. The rated load capacities of the crane, hoist, rope, chains, slings or other components may never be exceeded;
- Only certified lifting equipment (tackle) may be used to lift a load;
- No equipment (tackle) that has been used for towing may be used for lifting operations;
- Only an approved material box (skip box) may be used for lifting loose items or materials;
- Before commencing with a lift, it must be verified that no safety devices (including load limiting devices) have been bypassed, overridden or disconnected;
- To prevent the load from swinging as it is lifted, the hoist must be centred over the load (when using slings or chains) or positioned directly above the lifting point of the load;
- Hoisting ropes must be kept vertical. No side loading of a crane boom is permitted (i.e. A crane may not be used to make a side pull);
- Two full wraps of rope must remain on the hoisting drum at all times. If a lower hoist limit switch has been fitted, and it is working correctly, it should not be possible to lower the block below the point where less than two full wraps of rope are on the drum;
- Before commencing with a lift, it must be verified that all rigging connections are correct and secure. Slings, chains, or other lifting devices must be fully and securely seated in the saddle of the hook;
- Slack must be removed from the slings, chains and / or hoisting ropes before lifting the load. It must be ensured that multiple lines are not twisted around each other and that the hoist rope is not wrapped around the load;
- To ensure that the load is properly secured and balanced, it must initially only be lifted a few centimetres. Slings must be repositioned if required;
- Before moving a suspended load, it must be lifted high enough to clear all obstructions. The load must only be lifted to the height necessary to clear obstructions, and no higher;
- Directional movement must be made smoothly and deliberately (there must be no sudden acceleration or deceleration of the moving load). Abrupt, jerky movements of the load in any direction must be avoided;
- Tag lines must be used in situations where a load needs to be steadied or guided while suspended;
- When using tag lines to steady or guide a suspended load that is being moved using a mobile crane, personnel on foot must remain in sight of and in communication with the crane operator at all times, must never walk between the crane and the load, and must remain clear of the load and the crane at all times (at least 5 metres). The load must be moved at a slow walking speed;
- A suspended load must be monitored closely at all times;
- If a crane operator's view of a suspended load is unavoidably obscured (completely or partially), or if a suspended load is unavoidably obscuring (completely or partially) a crane operator's view, then suitably positioned spotters must be in place to provide guidance to the crane operator;

- A load MAY NOT be moved over, or be suspended above, any person or any occupied building. No person may walk beneath, or position himself below, a suspended load;
- No person may pass or work beneath the boom of a crane;
- No person may be positioned between a suspended load and a solid object where there is a risk of being crushed should the load swing;
- No person may be positioned within the radius of the boom of a crane unless directly involved with the lift;
- Under no circumstances may any person ride on a crane's hook or on a load;
- No load may be left suspended unless the operator is at the controls and is monitoring the load. In such a situation, the load must be kept as close as possible to the ground or floor to minimise the possibility of injury should the load drop;
- The controls of a crane or hoist may never be left unattended while a load is suspended. If it becomes necessary to leave the controls, the operator must lower the load to the ground or floor;
- With the exception of pick-up and carry operations, no lifting may be carried out using a mobile crane unless the outriggers have been deployed and are locked in position;
- Load spreaders or packing under the outriggers must be used irrespective of the underfoot conditions;
- Before a mobile crane is moved into position to carry out a lift, the area must be inspected by a suitably qualified person who must verify that the underfoot conditions are satisfactory;
- When using a mobile crane, slewing to test the effectiveness of the outriggers must be carried out prior to commencing with a lift;
- Slew pins must be securely in place while a mobile crane is travelling;
- Unauthorised use of a crane or hoist must be prevented by removing the keys, locking the cabin, isolating the controls, etc. When lifting operations have been completed;
- When not in use, lifting equipment must be stored off the ground and must be protected from the elements (rain, harsh sunlight, etc.) And contamination (dust, solvents and other chemicals) in order to prevent damage and / or deterioration.

A crane or hoist or an item of lifting equipment may only be used for the purposes for which it was designed.

16.12.4 Inspection, Testing and Maintenance

Any crane or hoist brought onto the project premises must have a current test certificate and record of inspection as well as a suitable checklist (derived from the crane or hoist manufacturer's inspection recommendations) for use by the operator(s) when carrying out pre-operation safety checks.

An Equipment Profile (dossier) must be compiled for each crane.

A register of all cranes, hoists and lifting equipment (tackle) brought onto the project premises must be compiled and maintained.

Each crane, hoist and item of lifting equipment must have a unique identification code or number, which must be referenced in the register.

For each crane, hoist and item of lifting equipment, the following documentation must be kept on site and must be made available (on request) to the nominated project management representative for inspection:

- Test records and certificates;
- Inspection records;
- Maintenance records; and

- Details of any modifications or repairs made.

All cranes, hoists and lifting equipment must be inspected, tested and confirmed fit for purpose (i.e. Safe for use):

- Before being operated or put into service;
- Before being returned to service following any repair or modification; and
- Periodically as follows (unless local regulations require examination more frequently):
 - Each crane or hoist (including all ropes, chains, hooks or other attaching devices, sheaves, brakes and safety devices that form an integral part of the crane or hoist) must be thoroughly examined by a competent, experienced and appointed person every 6 months;
 - Each crane or hoist must be subjected to an annual performance test (i.e. A load test) by a competent, experienced and appointed person; and
 - All lifting equipment (tackle) must be thoroughly inspected by a competent, experienced and appointed person every 3 months.
 - The system of inspection and testing must provide verification that each crane or hoist is able to function to its design specifications, and must verify the integrity of:
 - Mechanical and electrical components;
 - Controls;
 - Cables and all lifting attachments;
 - Structural components including boom, hoist, brakes, wheels, hooks, baskets, outriggers, hook-blocks and rails; and
 - Load limiting devices, hoist limit switches, alarms or warning devices, and other safety devices and control systems (including independent fail-safe braking systems, devices to stop the crane or hoist such as a dead man’s switch, and emergency shut-off switches).

A preventative maintenance system must be in place to ensure that all cranes and hoists are maintained in a safe and serviceable condition.

For any crane or hoist, all inspections, testing, maintenance and repairs must, as a minimum, be carried out in compliance with the requirements and specifications of the manufacturer as well as all applicable regulatory requirements (in terms of both the frequency of inspection, testing and maintenance, and the physical condition of the crane or hoist).

Repairs to a crane or hoist may only be carried out by competent persons. After repairs have been made, the crane or hoist must be tested and recertified fit for purpose (unless the repairs did not affect the integrity of the lifting mechanism).

Any modification to a crane or hoist must be subject to the approval of the original equipment manufacturer and a rigorous change management process.

Each item of lifting equipment (tackle) must be tagged following each quarterly (3-monthly) inspection. Details of these inspections must be recorded in the lifting equipment register which must be made available to the nominated project management representative on request.

The following colour coding system must be used for the tagging of all lifting equipment:

Table 16-1 colour coding system for lifting equipment

Quarter	Tag colour
January – march	Blue
April – June	Red
July – September	Green
October – December	Yellow

The tag placed on an item of lifting equipment must be traceable to an entry in the lifting equipment register where the following information concerning the inspection of that item of equipment must be recorded:

- Item description;
- Unique item identification code or number;
- Item owner;
- Item location;
- Date of inspection;
- Name and signature of competent person who carried out the inspection; and
- Any comments concerning the inspection.

Any item of lifting equipment that is found to be damaged or defective must be removed from service (and tagged, “out of service”) immediately and must then either be repaired and recertified (if possible) or destroyed to prevent further use.

Similarly, any lifting equipment that is known (or is suspected) to have been overloaded must be removed from service immediately and destroyed to prevent further use.

If an item of lifting equipment is removed from service or destroyed (scrapped), this must be indicated in the lifting equipment register.

Any item of lifting equipment without a tag or with an out-of-date inspection may not be used.

16.12.5 Training and competency

Only suitably trained, competent and experienced persons who have been authorised in writing by the contractor’s project manager are permitted to:

- Evaluate and plan critical lifts;
- Supervise lifting operations;
- Operate cranes and hoists;
- Use lifting equipment, and rig (sling) loads;
- Provide signals for controlling lifts; and
- Inspect, maintain or test cranes, hoists and lifting equipment.

Each operator must meet the competency requirements for the particular class or type of crane or hoist to be operated. Depending on the project location and applicable legislation, operators may need to hold a certificate of competency issued by a recognised training institution.

16.13 Working at heights

All applicable legislation concerning work performed from an elevated position must be complied with at all times.

Fall prevention or fall protection measures must be in place whenever the potential exists for a person to fall 2 metres or more.

16.13.1 Fall prevention

16.13.1.1 Work platforms

Wherever practical, a safe working area must be provided in the form of a work platform with fixed edge protection. This may include:

- a permanent work platform or walkway (i.e. A fixed steel structure);
- a fixed or mobile scaffold; or
- an elevating work platform such as a scissor lift, man lift, boom lift or cherry picker.

All work platforms and walkways elevated one metre or more must have complete floors, and edge protection must be in place in the form of toe boards and sturdy guard rails properly secured (i.e. bolted, welded, clamped, etc.) To prevent accidental displacement. Safe means of access and egress must be provided.

Guard rails must be capable of withstanding a force of at least 100 kilograms applied in any direction at any point.

The top rail must be positioned at a height of one metre above the working surface, and a mid-rail must be provided.

16.13.1.2 Floor openings, holes and edges

Any opening or hole (temporary or permanent) in a floor, platform or walkway must be protected by sturdy guard rails (removable if required) or a cover to prevent a person from stepping into or falling through the gap. Covers must be strong enough to support the loads that will be imposed on them and must be secured to prevent accidental displacement.

Ladder way floor openings and platforms must be protected by guard rails of standard construction and toe boards must be fitted along all edges, except at the entrance to an opening where a gate must be installed and so arranged that a person cannot walk directly into the opening.

When open, hatchways and floor openings must be protected by removable guard rails and toe boards of standard construction. When these openings are not in use, covers of adequate strength must be put in place and must be secured to prevent accidental displacement.

Where doors or gates open directly onto a stairway, a platform must be provided and the swing of the door or gate must not reduce the effective width of the platform to less than 500mm.

16.13.1.3 Wall openings

Wall openings, from which there is a drop of more than one metre, must be guarded as follows:

- When the height and position of the opening in relation to the working surface is such that standard guard rails will effectively eliminate the risk of accidentally falling through the opening, then these must be provided. The bottom edge of the opening must be fitted with a toe board. The guard rails and toe board may be removable if required;
- Alternatively, the opening may be closed using a screen. Wall opening screens must be of such construction and mounting that they are capable of withstanding a force of at least 100 kilograms applied horizontally at any point on the near side of the screen. A screen may be of solid construction, of grillwork, or of slat work.

An extension platform outside a wall opening, onto which materials can be hoisted, must have sturdy guard rails (or equivalent edge protection) on all sides. One side of the extension platform may have removable railings in order to facilitate the handling of materials.

16.13.1.4 Stairways

Each flight of stairs having four or more risers must be fitted with handrails. Handrails must be installed on both sides of every stairway. Riser height and tread width must be uniform throughout any flight of stairs, including any foundation structure used as one or more treads.

Stairways must be free of hazardous projections, such as protruding nails. No materials, equipment or waste may be placed on or beneath any stairway. All stairways must be well lit.

16.13.2 Fall protection

Whenever there is a risk of falling 2 metres or more, whenever there is a risk of falling onto dangerous equipment or machinery even if the potential fall distance is less than 2 metres, or whenever work must be carried out within 2 metres of an opening through which (or an edge over which) a person could fall, no work may commence unless:

- a fall protection (and rescue) plan is in place (prepared by a competent person, approved by the nominated project management representative, and implemented by the contractor);
- A detailed task-specific risk assessment has been carried out;
- A safe work procedure is in place for the task to be performed;
- A permit to work has been obtained; and
- Each person has been provided with suitable fall protection equipment.

Fall protection equipment (either fall restraint or fall arrest equipment) must be used at all times whilst the work is being carried out.

To prevent persons from falling, fall restraint equipment must be used whenever work must be carried out within 2 metres of an opening through which (or an edge over which) a person could fall.

Fall arrest equipment must be used whenever the potential exists for a person to fall 2 metres or more.

A person has been provided with suitable fall protection equipment if he is secured by means of an approved full body harness (well fitted) with two shock absorbing lanyards or an inertia reel (when fall arrest equipment is required) or two short restraining lanyards (when fall restraint equipment is required), double or triple action snap hooks (or karabiner type rings), and secure anchorage points (a person's lanyard may be attached either directly to an anchorage point or indirectly through the use of a variety of systems that incorporate a lifeline).

A dual lanyard system must be used to ensure that at least one connection point is maintained at all times.

Note: When selecting fall arrest equipment, care must be taken to ensure that the potential fall distance is greater than the height of the person plus the length of the lanyard with its shock absorber deployed (taking the height of attachment into account).

Anchorage points must, where practical, be above the head of the person, and must ensure that in the event of a fall the person will neither swing nor touch the ground.

All permanent anchorage points must be designed and approved by a professional structural engineer.

All anchorage points must be periodically inspected and tested by a competent person to ensure that they are secure and can support the required load. A system must be in place to identify anchorage points as authorised for use.

Temporary anchorage points (and lifeline systems) may only be used if a competent person has certified them safe to use.

If an elevating work platform is used, such equipment must be fitted with a fixed anchorage point for the attachment of fall protection equipment.

The use of fall protection (fall restraint or fall arrest) systems must be avoided wherever and whenever possible through design, the installation of physical barriers that protect persons from falling, and employing alternative methods of working.

Only if physical barriers protecting against free falls cannot be installed must fall protection equipment be used.

Fall protection (fall restraint or fall arrest) systems are items of personal protective equipment and, if required, must be purchased, installed and provided to employees.

Prior to commencing with any work at height, an assessment must be conducted to determine if the work requires the use of fall protection equipment, and if so, which fall protection system is the most appropriate for the work.

There must be a system for ensuring that fall protection equipment is:

- Tested and certified for use;
- Inspected by the user before use; and
- Destroyed following a fall or where inspection has shown evidence of excessive wear or mechanical malfunction.

All persons that are required to work at height (in order to carry out routine or non-routine tasks) must first be trained and certified competent to do so. Furthermore, each person must be in possession of a valid medical certificate of fitness specifically indicating that the person is fit to work at height.

All persons required to use personal fall protection equipment must be trained and certified competent in the correct selection, use, maintenance and inspection of such equipment.

All fall protection equipment must be thoroughly inspected on a monthly basis by competent persons appointed in writing and each item of equipment must be tagged to show when it was last inspected. All inspections must be recorded in a register.

On finding defective or damaged equipment, appropriate action must be taken by the competent person (i.e. the destruction of the equipment to prevent further use).

Persons making use of personal fall protection equipment must do so in strict accordance with the instructions or requirements specified by the manufacturer or supplier of the equipment or system.

Specific pre-use inspection, maintenance and fitting protocols must be established in accordance with the manufacturer's requirements or guidelines and these protocols must be followed by all users of the fall protection equipment.

Solvents may not be used to clean fall protection equipment. Only manufacturer-approved cleaning solutions may be used.

No person required to use personal fall protection equipment may work in isolation (a minimum of two persons working together is required).
Competent supervision must be in place at all times for all work carried out at height. Supervisors must be appointed in writing.

Emergency response (rescue) procedures for the rapid retrieval of suspended persons in the event of a fall from height must be prepared and tested.

Note: Even though there is no risk of free fall, fall protection equipment may be required in situations where there is a risk of falling, slipping or sliding down a slope of more than 45 degrees.

Note: The maximum service life of fall protection equipment manufactured of synthetic fibre shall be 5 years from the date of first use and / or manufacture unless otherwise specified by the manufacturer.

A person may climb or descend a ladder without fall protection provided that he is able to use both hands and legs to do so, faces the ladder, and uses one step at a time. The ladder must be tied off or supported at its base.

Prior to any roof work being performed, or prior to persons accessing a roof, a structural engineer must verify that the roof is of sound construction and that it is capable of supporting the weight of the persons as well as any equipment that may be required. Should the engineer's findings be to the contrary, alternative methods of performing the work must be found. Particular care must be taken when work is carried out on an asbestos cement roof or a fibreglass roof.

16.13.3 Risk Assessment and Permitting

The following documentation is required for any work where fall protection is required (i.e. where a risk of falling exists):

- A Fall Protection (and Rescue) Plan;
- A Risk Assessment for the task to be performed;
- A Safe Work Procedure for the task to be performed; and
- A Permit to Work.

As part of the Risk Assessment and planning processes, the following must be considered:

- Hazards relating to accessing the location at height;
- The nature of the work location;
- The nature of the work activities to be undertaken at height;
- Environmental and weather conditions;
- The presence of nearby persons who may be at risk due to falling objects (potentially) or who's activities may be affected by the work being performed at height;
- The selection of fall protection equipment (considering fall clearances) and / or access equipment;
- The selection of anchorage points;
- The load ratings of access platforms, work areas, anchorage points, etc.;
- The condition of supporting structures such as roofs;

- The need for the work to be carried out by multiple persons and the means of communication;
- A rescue plan that addresses retrieval or rescue contingencies;
- Working above open furnaces or molten metal;
- Exposure to heat sources;
- The use of a mobile elevating work platform, man basket, suspended scaffold or boatswain's chair; and
- Any other conditions that may affect the safe execution of the task.

16.13.4 Elevating Work Platforms

Before hiring or purchasing an elevating work platform (e.g. a scissor lift, man lift, boom lift, cherry picker or similar equipment), the certification of the equipment (with regard to suitability of design and construction) must be verified.

Before using an elevating work platform, it must be verified that the equipment is in good working order and has been serviced regularly. The service record and instruction manual must be kept on site. A system must be in place to ensure that the equipment is maintained and inspected as required by the manufacturer and / or local regulations.

Persons (operators) must be formally trained through an accredited training provider and certified competent in the operation of the equipment. Once a person has been issued with the necessary licence or qualification as required under local regulations, he must be appointed in writing to operate the equipment.

Before using an elevating work platform, the operator must inspect the equipment and a pre-use checklist must be completed.

The operator of an elevating work platform must be in the "basket" unless it can be demonstrated to the satisfaction of the nominated project management representative that this is not possible or practical.

Every person in the "basket" must keep his feet on the floor at all times.

Every person in the "basket" must be secured at all times by means of personal fall protection equipment attached to an approved anchorage point, and systems must be in place to prevent tools and equipment from falling.

A mobile elevating work platform must not be driven unless the "basket" has been lowered and secured in a stable position.

Every elevating work platform that is used must be equipped with a dead man's switch or foot pedal at the operator controls.

An elevating work platform must only be operated on a firm surface with the outriggers extended (where fitted).

An elevating work platform must not be operated on a grade or slope beyond the capability of the machine (every mobile elevating work platform that is used must be fitted with an inclinometer which sounds an audible alarm before the maximum safe incline has been reached).

The area beneath the "basket" and the boom must be barricaded.

A second competent operator of the mobile elevated work platform to be in place on the ground level – to ensure that the elevated work platform could be lowered in case of an emergency.

A spotter must be used at all times when moving a mobile elevating work platform and when the "basket" is in an elevated position.

16.13.5 Man Baskets, Suspended Scaffolds and Boatswain's Chairs

The use of a man basket, suspended scaffold or a boatswain's chair may only be considered when all other avenues to safely perform the work (e.g. ladder, scaffolding, mobile elevating work platform, etc.) have been exhausted. Authorisation to use a man basket, suspended scaffold or a boatswain's chair must be obtained from the nominated project management representative. If permission is granted, the use of such equipment must be in strict compliance with all applicable legislation.

A person working from a man basket or a suspended scaffold must remain within the basket and must keep his feet on the floor at all times.

Each person working from a man basket, suspended scaffold or a boatswain's chair must be in possession of a valid medical certificate of fitness and must be trained (and assessed competent) in the Safe Work Procedures pertaining to the use of the equipment, as well as the Fall Protection Plan.

Each person working from within a man basket or suspended scaffold or from a boatswain's chair must wear personal fall protection equipment at all times (i.e. an approved full body harness connected by means of a shock absorbing lanyard to an anchorage point or lifeline that does not form part of the basket or chair).

If suspended using a crane, the man basket, suspended scaffold or boatswain's chair must be visible to the crane operator at all times. A suitable means of communication must be in place to ensure that the suspended person(s) are able to communicate with the crane operator and personnel on the ground.

The crane operator must remain at the controls at all times while the man basket, suspended scaffold or boatswain's chair is occupied.

Where feasible (and if it is safe to do so), tag lines must be used to stabilise the man basket, suspended scaffold or boatswain's chair.

A man basket or suspended scaffold (including the suspension system) must be designed by a qualified engineer.

Only an approved and certified man basket or suspended scaffold may be used. Regulations may require approval by an authority or certification to a national or international standard. The manufacturer's procedures and conditions for use must be strictly complied with at all times.

Each man basket or suspended scaffold must be fitted with an information plate indicating the maximum weight and number of persons that may be lifted. Copies of the welding x-rays and engineering drawings must be kept on site.

Any work involving the use of a man basket, suspended scaffold or boatswain's chair must be carried out under the supervision of a competent person who has been appointed in writing.

A man basket, suspended scaffold or boatswain's chair must be thoroughly inspected (examined for damage) by a competent person prior to use (every time the equipment is used) and the results of each inspection must be recorded in a register. The crane or hoist as well as all lifting equipment (tackle) that is used to suspend the man basket, suspended

scaffold or boatswain's chair must be tested and inspected as stipulated in the Cranes and Lifting Equipment Standard.

All suspended scaffold erectors, operators and inspectors must be appointed in writing and proof of competency must be provided.

Persons carrying out welding or flame cutting work from within a man basket or suspended scaffold or from a boatswain's chair must take precautions to ensure that they do not accidentally cut or burn through the cables or wire ropes that are suspending them.

16.13.6 Falling Objects

In the process of planning work activities, the risks associated with falling objects (i.e. materials, tools or equipment) must be assessed and appropriate control measures must be identified, implemented, and monitored taking the following hierarchy of controls into consideration:

- Preventing objects from falling – by using containment sheeting, toe boards, lanyards to secure tools (to a person or to the structure), ropes or chains to secure equipment (to the structure), lift boxes, brick cages, etc. and by properly securing loads when lifted by crane or hoist;
- Protecting people from falling objects – by establishing barricaded exclusion zones, installing catch platforms or catch nets, displaying warning signage, and posting safety watchers and / or traffic controllers; and
- Personal Protective Equipment (particularly safety helmets and safety boots) – protective equipment is a last line of defence and must be worn.

Where overhead work is being carried out, barricading must be erected around the work area (at the level at which the work is taking place and at every level below including ground level) to prevent persons from entering such an area and potentially being struck by falling objects.

Wherever hazards related to falling objects exist, appropriate warning signage (i.e. "Overhead Work In Progress" and "No Unauthorised Access") must be prominently displayed.

No items are permitted to lie loose in elevated positions (e.g. nuts and bolts must be securely stored) and good housekeeping standards must be maintained at all times.

No tools, equipment, material, debris, waste, etc. may be dropped from height. Objects must be lowered or chuted to ground level in a safe and controlled manner.

16.13.7 Scaffolding

16.13.7.1 Training, Competency and Supervision

Scaffolding may only be erected, maintained, altered or dismantled under the strict personal supervision of a competent Scaffolding Supervisor (or Scaffolding Inspector) who has been appointed in writing.

Scaffolding may only be erected, maintained, altered or dismantled by competent and appointed Scaffolding Erectors (or Scaffolding Builders). It is the Scaffolding Supervisor's responsibility to ensure that all persons carrying out such work are suitably trained and experienced.

A certificate of competency issued by a reputable (i.e. accredited and approved) training provider must be produced for each Scaffolding Supervisor and each Scaffolding Erector.

16.13.7.2 Erection and Dismantling of Scaffolding

Only approved scaffolding components may be used to erect a scaffold. Scaffolding must be erected, modified and used in accordance with the manufacturer's guidelines or recommendations, and in strict compliance with all applicable legislation and standards.

A free-standing scaffold must not exceed a height of three times the smallest dimension of its base.

Scaffolds with a height to base width ratio of more than 3:1 must be restrained from tipping over by guying, tying, or bracing.

Guy wires and ties prevent scaffolding from tipping away from the building or structure, and braces are rigid supports that prevent the scaffolding from tipping into the building or structure.

Scaffolding must be secured to the structure every 6 metres vertically and every 9 metres horizontally (as a minimum). Adequate underpinning, sills or footplates must be provided for scaffolds erected on filled or otherwise soft ground (including sand or gravel).

If the scaffolding is to be load bearing (i.e. other than normal access and workplace storage) then full calculations and a design must be prepared and authorised in writing by a structural engineer. The load limits specified by the scaffolding manufacturer may not be exceeded under any circumstances.

Scaffolds must be plumb and level at all times.

All scaffolding components must be in good condition (i.e. undamaged and free of corrosion).

All scaffolding components must be properly connected or secured and scaffolding must be effectively braced (diagonal bracing).

Each person erecting, maintaining, altering or dismantling scaffolding must use fall protection at all times (i.e. a full body safety harness with two shock absorbing lanyards fitted with scaffold hooks). The work must be planned to enable every Scaffolding Erector to be securely anchored at all times. A suitable lanyard length (not exceeding 2 metres) must be selected taking the potential fall distance and height of attachment (height of anchorage point) into account. If the lanyard is too long or the anchorage point is too low, the person may hit the ground, a platform, or objects below him before the lanyard is able to break his fall.

The area around the base of a scaffold must be barricaded to prevent unauthorised access into the work area. When scaffolding is erected or dismantled on a level, platform, or floor lying above ground level and the potential exists for components to fall to levels below the level on which the scaffolding is positioned, then the area directly below the scaffolding on each of those levels must also be barricaded. Appropriate warning signage (i.e. "Overhead Work In Progress" and "No Unauthorised Access") must be prominently displayed.

Hoists, lifts and approved material baskets must be used (where available) to lift scaffolding components to elevated positions.

Where components are passed from hand to hand during the erection or dismantling of a scaffold, each Scaffolding Erector must always stand on three boards and not directly above the person below him. During this process, each Scaffolding Erector must remain within the confines of the scaffold and must expose as little of his body as possible to

minimise the risk of being struck by a falling component. Good communication between team members must be maintained at all times.

No scaffolding components, tools, or any other material may be dropped from height or thrown from one level to another. Components, tools and materials must be lowered or lifted in a controlled manner. Use may be made of a chute.

Each tool must be secured to the wrist, harness or structure by means of a lanyard. A tool bag (around the waist or over the shoulder) may be used for carrying tools up and down a scaffold structure. Tools or equipment may not be carried by hand up or down a structure, as both hands must be used for climbing. If necessary, a rope must be used for lifting or lowering tools or equipment.

While a scaffold is being erected or dismantled, no scaffolding components may be stacked on the scaffold structure unless it has been designed for that purpose. Any loading of a scaffold structure must be authorised in writing by a structural engineer.

For special scaffolding, a design must be prepared by the appointed Scaffolding Supervisor and this design must be authorised in writing by a structural engineer before the scaffolding is erected.

Scaffolding may not stand on steel grating unless the grating is adequately supported from below. Scaffolding must rather stand on the structure that supports the grating.

Empty drums, crates or bricks may not be used to prop up, support or anchor scaffolding. Before scaffolding is erected in close proximity to an electrical installation or live conductors, an electrical engineer (employed by Project or the client) must inspect the area and determine whether or not the scaffolding must be earthed. Should the scaffolding require earthing, this must be done as soon as possible while the scaffolding is being erected.

Scaffolding may not be erected if it is raining or in winds stronger than 32 km/h.

A green tag (displaying the words, "Scaffold Safe for Use") or a red tag (displaying the words, "Danger: Do Not Use Scaffold") must be prominently displayed on each scaffold at all times. The tag must be positioned close to the base of the ladder or staircase provided for safe access. The wording on the tags must be in English and any other language commonly used on site.

As a minimum, a green tag must display the Scaffolding Supervisor's name, the date that the scaffold was erected, and the date that the scaffold was last inspected.

Only an appointed Scaffolding Supervisor may attach, change, update the information on, or remove these tags.

Scaffolding must not be:

- Left partially erected or partially dismantled except for normal work stoppages (for example, over weekends);
- Left in an unsafe condition (if scaffolding is unavoidably in an unsafe condition, barricading must be in place to prevent unauthorised access and the required red tags must be prominently displayed on the scaffold structure); or
- Moved or altered while work is in progress.
-

Mobile scaffolding must be equipped with brakes, which must be engaged at all times when the scaffolding is in use. A scaffold may not be moved if any person is on the structure.

16.13.7.3 Safe Access

Safe and convenient access must be provided to every scaffold platform by means of properly installed ladders or approved stairways, which must remain unobstructed at all times. Climbing up or down a scaffold on the braces or ledgers is forbidden.

All ladders used to access scaffolding must be securely attached to the scaffold structure. Hook-on and attachable ladders must be specifically designed for use with the type of scaffolding being used.

If a ladder is used to access a scaffold platform at a height greater than 1.5 metres above the ground, then the ladder must be secured internally (i.e. within the scaffold structure) and there must be an opening (closed with a trap-door) in the platform at the top of the ladder.

If the scaffold platform is at a height of less than 1.5 metres above the ground, then the ladder may be attached externally provided the guard rails around the platform are modified to allow access (the opening in the guard rails must be kept closed using a self-closing gate). No person may climb over or through the guard rails to gain access to a platform.

If a vertical ladder used on scaffolding is more than 5 metres in length it must be equipped with a ladder cage extending from a point 2 metres from the base of the ladder to a height of 1 metre above the platform (or the uppermost platform) that the ladder is providing access to.

Circular ladder cages must have an internal diameter of no more than 700mm. Square ladder cages must have internal dimensions of no more than 700mm by 700mm.

The requirement for a ladder cage may be waived if platforms are provided at height intervals not exceeding 4 metres, with the vertical ladder secured on the inside of the scaffolding framework and an opening (closed with a trap-door) in each platform. Vertical ladders must be braced at three metre intervals (as a minimum) to prevent undue movement.

All vertical ladders providing access to a platform must be left in place for as long as the scaffold remains in place and must be inspected as part of the scaffold structure. Any deviation from the requirements stipulated above must be subjected to a risk assessment and the nominated project management representative must authorise the deviation in writing.

16.13.7.4 Scaffolding Platforms

Safe work platforms must be provided.

Every work platform must be complete (i.e. from ledger to ledger and from transom to transom without any gaps) in order to prevent personnel, materials, tools, etc. from falling through the platform.

Every work platform must be constructed from manufactured steel scaffold boards (planks) of equal thickness (height). Timber boards are not permitted under any circumstances.

Each steel scaffold board must be securely hooked (fastened) onto the ledgers or transoms that support it.

On all sides except the one facing the structure, every scaffold platform must be provided with:

- Sturdy guard rails positioned 500mm above the platform floor (the mid rail) and 1000mm above the platform floor (the top rail); and
Steel toe boards that are at least 150mm high and securely attached such that no gap exists between the toe boards and the platform floor.

- **Note:** Wire mesh infill panels incorporating a toe board may be used instead of a mid-rail.

Scaffold platforms must be as close to the structure as is practicable (but not closer than 75mm) except where personnel need to sit on the edge of the platform while they work in which case the distance may be increased to no more than 300mm.

Scaffold platforms must, at all times, be kept free of waste, protruding objects, and any other obstructions. Platforms must be cleaned if necessary to ensure that they are maintained in a non-slip state.

16.13.7.5 Inspection of Scaffolding

Every scaffold structure must be inspected by a competent Scaffolding Supervisor:

- Prior to use after erection, and at least weekly thereafter;
- After inclement weather (heavy rain, strong winds, etc.);
- After any incident resulting in jarring, tilting or overloading;
- After any alteration is made; and
- Before being dismantled.

On completion of an inspection, the Scaffolding Supervisor must update the information on the scaffold tag.

A record of each inspection (date and time of inspection, location of scaffolding, findings, etc.) must be captured in a register. The register(s) must be maintained by the Scaffolding Supervisor(s) carrying out the inspections.

16.13.7.6 Using Scaffolding

The user of a scaffold (i.e. the responsible supervisor) must inspect the erected structure prior to acceptance and must ensure, as far as is reasonably possible, that the scaffold is safe and fit for purpose before allowing his team to make use of the scaffold.

In particular, the user must ensure that:

- The scaffold and the platforms have been constructed to meet the loading requirements of the work that is to be carried out (the Scaffolding Supervisor must be consulted in this regard);
- The Scaffolding Supervisor has checked that adequate ties and braces are in place;
- The work platforms are in the correct positions and are complete with toe boards and guard rails;
- Safe and convenient access has been provided (ladders and / or stairways); and
- A green ("Scaffold Safe for Use") tag has been attached to the scaffold by the Scaffolding Supervisor.

Use of an incomplete or unsafe scaffold is prohibited. Unsteady or non-rigid scaffolds must not be used and inadequacies must be reported to, and rectified by, the responsible Scaffolding Supervisor.

The user of a scaffold must ensure that every person in his team is aware that no alterations to the scaffold may be made by the team during the course of their work, and that if any alterations are required, they must be made by competent Scaffolding Erectors under the supervision of an appointed Scaffolding Supervisor.

A scaffold may not be used:

- If a red tag is displayed indicating that the scaffold is not safe to use; or
- During inclement weather, defined as wind speeds greater than 40km/h, thunderstorms, or heavy rain (in excess of 40mm/h).

Note: With due consideration of possible educational limitations, the contractor must ensure that all persons understand what green and red tags mean.

The area around the base of a scaffold must be appropriately barricaded to prevent unauthorised access into the work area. Appropriate warning signage (i.e. "Overhead Work In Progress" and "No Unauthorised Access") must be prominently displayed.

Loose tools and / or materials on scaffold platforms must be secured using lanyards, wire or fibre rope, or must be placed in secured containers. Where appropriate, "catch nets" deemed may be installed as an additional safety measure to prevent materials or tools from falling to the ground.

The storage or placement of materials on scaffolding platforms must be kept to a minimum. Debris as well as tools and materials that are no longer required must be removed from all working platforms at least once per day.

Scaffolding platforms must be cleaned regularly.

A heavy load may not be placed on a scaffolding platform unless the scaffold has been designed and constructed specifically for that purpose. Any loading of a scaffold structure must be authorised in writing by a structural engineer.

Scaffolds may not be used as hoisting towers or to support piping or equipment. Each person working from scaffolding must wear fall protection (i.e. a full body safety harness with two shock absorbing lanyards fitted with scaffold hooks) and must be securely anchored at all times.

All work must be carried out from properly constructed work platforms. Standing on railings or braces in order to perform work is forbidden. Drums, boxes and other makeshift substitutes for scaffolding may not be used under any circumstances.

Where work on an electrical system is to be undertaken from a scaffold, an electrical engineer (employed by Project or the client) must determine whether or not the scaffolding structure requires bonding and earthing. The scaffolding may not be used until this has been determined, and if required, until the structure has been bonded and earthed.

16.13.7.7 Identification and Inspection of Scaffolding Components

All scaffolding components belonging to a contractor must be properly marked or uniquely coloured to enable positive identification.

Prior to erecting a scaffold, all scaffolding components must be carefully inspected by a competent Scaffolding Supervisor.

Components found to be defective during an inspection must be conspicuously marked and removed to a suitably demarcated quarantine area for destruction, repair, refurbishment or removal from site. Deformed and bent wedges must be straightened and inspected for cracks before being put back into service.

16.13.7.8 Storage of Scaffolding Components

All scaffolding components must be stored in a demarcated storage area in such a manner that they are not exposed to environmental extremes and will not cause injury to persons. Suitable barricading or fencing must be erected and warning signage must be posted (e.g. No Unauthorised Entry).

Within a storage area, scaffolding components must be stacked such that pathways (750mm in width) are maintained between the stacks. Each stack must be stable and components must be neatly placed to ensure that no ends protrude into any pathway. The various components must be stacked separately.

The weight of scaffolding components must be considered when stacking them in elevated positions.

Any storage area for scaffolding components must be positioned such that it will not interfere with any onsite activity (including the operation of any plant or equipment), block any access way, or obstruct access to any plant or equipment. Before establishing a storage area, the location must be agreed with the nominated project management representative.

16.13.8 Ladders

All ladders used on site must be of sound construction and adequate strength. Only non-conductive ladders made of wood or fibreglass may be used for electrical work or work being performed in proximity to energised electrical equipment. Metal ladders and ladders with metal reinforcing may not be used.

The use of makeshift ladders is forbidden.

All ladders must be numbered, listed in a register, and inspected by a competent person on a monthly basis (the results of each inspection must be recorded in the register). Before using a ladder, the user must inspect it for damage.

Ladders with missing, broken, cracked or loose rungs, split stiles, missing or broken spreaders (stepladders) or any other form of damage or defect may not be used. A damaged ladder must be removed from service (and tagged, "Out of Service") without delay and must then either be repaired (if possible) or destroyed to prevent further use. Persons must receive instruction in the correct use and proper care of ladders.

Ladders may only be used as a means of access and egress. The use of ladders as working platforms is prohibited, except for inspection and carrying out minor tasks (i.e. light work and short duration) such as changing a light bulb.

Ladders may not be positioned horizontally and used as walkways or runways or as scaffolding.

All portable ladders must be fitted with non-skid safety feet (or some other means to prevent the base of the ladder from slipping) and the feet must always be placed (stand) on a firm level surface.

The use of bricks, stones, wood or any other material to level the stiles of a ladder is prohibited.

Ladders may not be placed on movable bases such as boxes, tables, trucks, etc.

The base or foot of a ladder must always be secured to prevent it from slipping. The ladder must be held by an assistant if the base cannot be secured in any other way (e.g. tied off).

A straight ladder must extend at least one metre above its support (or above the working platform that it is providing access to). The top of the ladder must be tied off (or otherwise secured to its support) to prevent accidental movement.

A straight ladder must be placed at a safe angle, i.e. tilted at a ratio of approximately 4:1, meaning that the base of the ladder must be one metre away from the wall (or other vertical surface) for every four metres of height to the point of support.

A stepladder may never be used as a straight ladder. A stepladder must be opened fully and the spreaders must be locked securely.

When using an extension ladder, at least four rungs must always overlap at the centre of the ladder.

Ladders may not be joined together unless they have been specifically designed and manufactured for that purpose.

A suspended ladder (i.e. not standing on a base) must be attached in a secure manner to prevent undue swinging or swaying, and to ensure that it cannot be displaced.

A ladder may not be placed against a window, glass or any other material which is unlikely to withstand the force exerted on it by the top of the ladder.

A ladder may not be placed in front of a door or window that opens towards the ladder unless the door or window has been locked or barricaded.

When a ladder is used near an entrance or exit, the base of the ladder must be barricaded. Materials and / or equipment may not be placed in close proximity to the base or landing of any ladder.

When ascending or descending a ladder, a person must always face the ladder and use both hands (i.e. maintain three points of contact).

Nothing may be carried up or down a ladder if it prevents the person from holding on to the ladder with both hands. Tools must always be properly secured. This can be achieved by attaching them to the wrist using lanyards or placing them in a tool belt around the waist. Tools and materials may also be carried in a bag over the shoulder or hoisted to the landing using a tool bag and rope.

Only one person at a time may use (i.e. be positioned on) a ladder.

No person may stand or step above the third rung from the top of a straight ladder or above the second highest step of a stepladder.

Overreaching from a ladder is prohibited. If the target is not within comfortable reach, the person must climb down and reposition the ladder.

No person may run up or down a ladder, or jump from the lower rungs or steps to the ground.

All ladders must be properly maintained and cared for.

Ladders must be stored under cover and should be hung in a horizontal position from several brackets.

No ladder may be left lying on the ground or be left exposed to the weather. A ladder left lying on the ground presents a tripping hazard and it may be damaged by vehicles running over it.

No ladder may be left in such a position where it may fall over, be accidentally knocked over, or be blown over by the wind.

Ladders may not be painted, as the paint may conceal damage, defects, labels or other markings.

Instead of paint, clear varnish or wood oil may be used to preserve wooden ladders.

Ladders must be kept clean, as dirt may conceal damage or defects. Oil or grease accumulation on the rungs of a ladder may cause a person to slip.

Before making use of a ladder, each person must make an effort to remove mud, oil, grease, etc. from his boots.

16.14 Permit to Work

All personnel must comply with the Permit to Work system applicable to the project.

A Permit to Work must be obtained before carrying out any work that involves:

- A hazardous energy source or system, including electricity, compressed fluids (e.g. hydraulics and pneumatics), chemical substances (e.g. toxic, corrosive, flammable or explosive gases and liquids), heat (e.g. steam), radiation, and machinery or materials with potential energy (gravitational and elastic) – isolation and lockout may be required;
- Confined space entry;
- Working at height;
- A critical lift;
- Hot work outside of designated workshops;
- Excavation; or
- A service (e.g. water supply, fire suppression systems, etc.).

Note: A Permit to Work may only be issued by an Authorised Person, and may only be received (or accepted) by an appointed Applicant (see Definitions).

Each Permit to Work that is issued must make reference to an approved Task-Based Risk Assessment for the work that is to be carried out.

The Permit to Work system that is employed must incorporate the following basic procedures:

- Prior to meeting with the Authorised Person, the Applicant must familiarise himself with all of the hazards associated with the system, plant, equipment, structure or area on or in which the work must be performed. He must

also consider the risks that may arise as a result of the tasks that will be carried out. A Task-Based Risk Assessment must be in place;

- The Applicant must then request permission to carry out the work and must meet with the Authorised Person to discuss and document the scope of the work as well as the hazards, risks and associated control measures. Isolation and lockout requirements must be identified (if applicable). The isolation and lockout process must be initiated by the Authorised Person who must contact the necessary Isolation Officers.

Note: The Applicant must ensure his own safety and that of his team, and has the right to accompany the Isolation Officers to verify that all of the necessary locks have been fitted to all of the isolation and lockout points in accordance with the applicable plant or equipment-specific Isolation and Lockout Procedure.

- Once all of the necessary isolations have been completed and the necessary Clearance Certificates have been issued by the Isolation Officer(s) (if applicable), and the Authorised Person is satisfied that the system, plant, equipment, structure or area is safe to work on or in provided all identified precautions are observed by the Applicant, then he must issue (sign) the Permit to Work to the Applicant;
- The Applicant must accept (sign) the Permit to Work. If equipment has been isolated, the Applicant must attach his Personal Lock to the relevant Isolation Bar (or Local Isolation Point) and must ensure that every other person working on the isolated equipment also attaches his or her Personal Lock to the Isolation Bar (or Local Isolation Point) before starting any work;
- Before commencing with any work, the Applicant must discuss the hazards, risks, control measures, precautions and limitations as stated in the Permit to Work (and associated Task-Based Risk Assessment) with all personnel who will be carrying out the work. A register must be kept and all persons must sign the register once they have been briefed by the Applicant;
- The work performed must be limited to what is described in the Permit to Work;
- When a particular employee has completed his work, he must sign the personnel register to this effect and (if applicable) must remove his Personal Lock from the Isolation Bar (or Local Isolation Point);
- Once all work is complete, the Applicant must:
 - Ensure that all machine guards have been replaced;
 - Ensure that all tools and materials have been removed from the work area;
 - Ensure that the work area is clean and tidy;
 - Ensure that all Personal Locks (including his) have been removed from the Isolation Bar or Local Isolation Point (if applicable);
 - Inform the Authorised Person that the work has been completed; and
 - Sign off the Permit to Work.
- Once the work is complete and the Applicant has signed off the Permit to Work, the Authorised Person must:
 - Ensure that the relevant Isolation Officers perform all of the necessary de-isolations (if applicable);
 - On completion of the de-isolations, sign off the Permit to Work accepting the system, plant, equipment, structure or area back for service; and
 - Inform all relevant personnel that the system, plant, equipment, structure or area is ready to use.

- Where the work must continue over more than one shift, the Permit to Work must be reviewed at every shift change by an Authorised Person. If the scope of work has changed, the permit must be cancelled and a new permit must be issued.

If any of the original conditions or precautions pertaining to the work is not being complied with, is no longer adequate or is no longer applicable, the Authorised Person must cancel the Permit to Work and must ensure that all work stops until full compliance with either the original or amended (as required) conditions and precautions is achieved and a new permit has been issued.

The Applicant must ensure that the Permit to Work (including the personnel register) is kept where the work is being carried out (i.e. posted on a portable Health and Safety Management Information Notice Board) and that the work is monitored against the permit conditions.

All Permit to Work records must be retained and must be made available for inspection when required.

The implementation of the Permit to Work system applicable to the project must be audited on a regular basis by a nominated project management representative. Furthermore, planned task observations must be carried out periodically.

Note: In addition to obtaining Permits to Work as and when required for specific hazardous activities (identified in this standard), each contractor must obtain a General Work Authorisation from a nominated project management representative on a monthly basis. A General Work Authorisation is valid for one calendar month and authorises the contractor's planned work activities. In order to obtain a General Work Authorisation, the contractor must provide a documented work plan for the month together with the necessary Task-Based Risk Assessments.

16.15 Isolation and Lockout

Isolation and lockout procedures that make it impossible to inadvertently energise any system, plant or equipment so isolated, must be in place for all work where hazardous energy sources exist, including electricity, compressed fluids (e.g. hydraulics and pneumatics), chemical substances (e.g. toxic, corrosive, flammable or explosive gases and liquids), heat (e.g. steam), radiation, and machinery or materials with potential energy (gravitational and elastic). These procedures must be strictly enforced.

All personnel must comply with the isolation and lockout system and procedures applicable to the project.

All Isolation and Lockout Procedures must incorporate the following basic requirements:

- The issuing of a formal Permit to Work for any work that requires the isolation of any system, plant or equipment;
- The use of defined Equipment, Discipline and Personal Locks (see Definitions), and multiple lockout systems (i.e. Isolation Bars and lockout hasps);
- Clear identification of all isolation and lockout points ensuring there is no duplication;
- Isolation of the main energy source;
- The use of slip plates or the blanking off of pipelines or ducting, in addition to the chaining and locking of valves, as determined by a risk assessment;
- Suitable methods of preventing the movement of equipment; and
- Methods to test the effectiveness or completeness of the isolation.

Note: No work may commence on a system, plant or equipment until a Permit to Work has been issued by an Authorised Person.

Note: A Permit to Work may only be issued by an Authorised Person once all required Clearance Certificates have been issued by appointed Isolation Officers.

The isolation and lockout system that is employed must incorporate the following basic procedures:

- In accordance with a system, plant or equipment-specific Isolation and Lockout Procedure, an appointed Isolation Officer(s) must isolate all points that need to be isolated in order to render the system, plant or equipment safe to work on. An Equipment Lock (and a suitable, highly visible warning tag) must be attached to each isolation point;
- On completion of an isolation (and lockout), the Isolation Officer must clear the area of all persons and must then carry out tests to ensure that the isolation is effective. This may be done by pressing a start button or by asking a control room operator to try to start the equipment. Special care must be taken to ensure that the attempted starting of the equipment has not been deactivated by another interlock forming part of the system, or by a different up-stream isolation. Alternatively, appropriate equipment may be used to test for energy (e.g. voltage verification or continuity tests).

Note: In the case of electrical isolation, a test for voltage must be carried out, after the switching device, to ensure the absence of voltage.

- The Isolation Officer must place the key to the Equipment Locks on an Isolation Bar (at a Lockout Station) and must then attach a Discipline Lock (to prevent the key from being removed) before issuing a Clearance Certificate;
- The Discipline Lock must remain in place when handing over to subsequent shifts. All Discipline Locks for a particular discipline (e.g. low voltage electricity) must be keyed-alike so that any Isolation Officer appointed for that discipline (and issued with a key) can open any of the Discipline Locks used for that discipline. This enables an Isolation Officer to de-isolate equipment that may have been isolated by another Isolation Officer during an earlier shift. Appointed Isolation Officers for a particular discipline are the only persons permitted to hold keys to the Discipline Locks used for that discipline.

Note: Local isolations do not require the use of Equipment Locks (a Discipline Lock may be attached to the Local Isolation Point by the Isolation Officer, followed by the necessary Personal Locks).

Note: For local isolations, if the Isolation Officer is the only person who will be working on the isolated equipment, then he must attach his Personal Lock to the Local Isolation Point.

- Once all required Discipline Locks are in place (i.e. attached to the Isolation Bar) and all Clearance Certificates have been issued, the Permit to Work may be issued by the Authorised Person;

- Each person who will be working on the isolated system, plant or equipment must then attach his or her Personal Lock to the Isolation Bar before starting any work (including the Isolation Officer, if he intends to work on the isolated unit);
- The attachment of a Personal Lock to the Isolation Bar prevents the removal of the key to the Equipment Locks even if the Discipline Lock is removed;
- When called (by an Authorised Person) to de-isolate the system, plant or equipment (on completion of the work under the Permit to Work), the Isolation Officer must ensure that all Personal Locks have been removed from the Isolation Bar before removing the Discipline Lock and the key to the Equipment Locks;
- Before removing the Equipment Locks and de-isolating the energy source, the Isolation Officer must inspect the system, plant or equipment that was worked on to ensure that it is safe to perform the de-isolation. This includes guard inspections, housekeeping, ensuring that all doors and covers are in place, and most importantly, ensuring that no persons are present;
- Once all Equipment Locks have been removed and the system, plant or equipment is safe for use, the Isolation Officer must cancel the Clearance Certificate and inform the Authorised Person that the unit has been de-isolated.

Where a system, plant or equipment is sequence interlocked and a hazard could be created through the inadvertent start up or shut down of a system, plant or equipment lying before or after the unit to be worked on, then that system, plant or equipment must also be isolated and locked out.

Redundant or out of service equipment must, in addition to being isolated and locked out using the relevant Discipline Lock, be fitted with a tag indicating why it is out of service, who performed the lockout, and the hazards associated with that equipment.

Where it is necessary to work on live equipment for the purposes of commissioning, testing, adjusting and sampling, such work must be carried out in accordance with a written Safe Work Procedure and controls must be in place to prevent unauthorised access into the work area.

The implementation of the isolation and lockout system and procedures applicable to the project must be audited on a regular basis by a nominated project management representative. Furthermore, planned task observations must be carried out periodically.

16.15.1 Personal Locks

A Personal Lock must be such that it can only be unlocked by the person to whom it belongs. Combination locks may not be used.

A Personal Lock, as well as the key(s) to the lock, must be kept under the exclusive control of the person to whom the lock belongs.

A Personal Lock must be issued to each person who requires one, and the person's details must be clearly and permanently engraved directly onto his Personal Lock. Alternatively, a thick durable plastic identification tag may be used that clearly displays the company's name, the employee's name, the employee's company number, and a contact telephone number (the tag must be securely fastened to the Personal Lock). Where the above is hand written, it must be done using a permanent marker pen and it must be legible.

Each person issued with a Personal Lock must be trained and certified competent in the correct use of such a lock.

A Personal Lock may NEVER be removed by anyone other than the person to whom it belongs, except if the removal (cutting) of the lock is authorised by the nominated project management representative (in the absence of this person, authorisation can only escalate upwards). Furthermore, the removal of the lock must be done under the personal supervision of the nominated project management representative, and in accordance with a written procedure. The removal (cutting) of a Personal Lock may be required if the person who applied the lock is unable or unavailable to remove it on completion of the work (e.g. lost his key, failed to remove his lock before going home, etc.).

16.16 Electrical Safety

All electrical work must be carried out by competent personnel in accordance with all legal requirements, codes, design criteria and safety standards applicable to the project.

Each contractor carrying out electrical work on the project site(s) must develop, document and implement Safe Work Procedures that are aligned with the requirements of this standard.

All persons who will be carrying out electrical work must be certified against the requirements of job and equipment-specific electrical competency standards for the project, which must address job and equipment-specific Safe Work Procedures.

Each person potentially exposed to electrical hazards must receive electrical hazard training at the commencement of his employment on site and thereafter on an annual basis. The training must address the equipment and conditions specific to the area where the individual will be working. The training material must be documented and training records must be kept.

16.16.1 Electrical Installations

Each electrical installation (temporary or permanent) installed or worked on by a contractor must be inspected by a nominated project management representative to ensure that the installation complies with all statutory requirements, codes, design criteria and safety standards applicable to the project.

A nominated project management representative must approve all electrical work before the installation is energised. Any installation deemed unsatisfactory by a nominated project management representative must be removed, repaired or modified by the contractor at his expense.

For every permanent or temporary electrical installation, a certificate of compliance must be issued by a competent and appropriately qualified electrician. These certificates must be available for inspection.

Single line diagrams (with supporting documentation) must be produced and maintained for all electrical installations. This information must include system fault calculations, equipment details, electrical protection discrimination curves, and cable ratings.

Work on electrical installations (new installations, and modifications or repairs to existing installations) may only be carried out by qualified and authorised personnel (i.e. electricians).

Electrical safety devices (specifically, earth leakage protection and overcurrent protection) must be installed on all distribution circuits and the settings must be established by suitably qualified personnel.

A suitable numbering and / or labelling system must be used so that each circuit breaker or earth leakage device can be clearly and readily matched with the outlet or equipment that it protects.

To ensure the safety of the user, each distribution panel must be completely enclosed, must be of the dead-front type, and must be properly constructed and earthed.

All electrical cabling must be covered (e.g. in cable trenches) or elevated (in cable trays) to protect it from damage and to eliminate tripping hazards.

All permanent and temporary electrical installations (cabling, sockets, distribution panels, transformers, switchgear, etc.) must be inspected and tested by a competent and suitably qualified electrician on a monthly basis. The testing must include a grounding (earthing) continuity test and testing of the electrical safety devices. Details of these inspections and tests must be recorded in a register which must be made available to the nominated project management representative for inspection.

A rigorous Isolation, Lockout and Permit to Work system must be applied to all electrical work (i.e. work on electrical installations, machinery or equipment). All personnel must comply with the system and procedures applicable to the project.

Before any work on an electrical installation or equipment is carried out, the installation or equipment must be de-energised.

No electrical work may be performed live, regardless of the voltage, unless written approval is obtained from the nominated project management representative (a

justification as to why it is necessary for the work to be carried out with the equipment in an energised state must be provided).

For all energised electrical work, a Safe Work Procedure must be in place and, with the exception of voltage testing and where no tools are used, a Permit to Work (specifically authorising energised electrical work) must be issued.

When carrying out any energised electrical work, approved electrically insulated gloves, blankets, mats and other protective equipment must be used.

Control centres, switchgear rooms, substations, generators, transformers, capacitor banks, and other similar electrical plant and equipment must be appropriately guarded and labelled and, with the exception of emergency shut-off mechanisms, must be made inaccessible to unauthorised personnel (i.e. plant or equipment of this nature must be positioned within rooms or fenced enclosures which must be kept locked).

Appropriate warning signage must be prominently displayed within, and at all entrances to, these rooms or enclosures. The signage must indicate that unauthorised persons are prohibited from entering, that unauthorised persons are prohibited from handling or interfering with any electrical plant or equipment, the procedure to be followed in the event of a fire, and the first aid procedure to be followed should a person suffer electric shock. Suitable fire-fighting equipment must be provided in all such rooms or enclosures.

All electrical panels must be kept locked (using keyed-alike padlocks). Keys may only be issued to authorised personnel.

All un-insulated (bare) or partially insulated conductors must be enclosed and protected to prevent accidental contact therewith. Measures must be taken to prevent unauthorised access and appropriate warning signage must be conspicuously displayed.

Only authorised persons may enter rooms or enclosures housing electrical plant or equipment, and only authorised persons may access electrical panels or cabinets, and cable ducts or trenches. If any work must be carried out in such an area or on such equipment, a Permit to Work must first be obtained from the nominated project management representative.

No connection to any electrical system may be made without prior approval and a valid Permit to Work from the nominated project management representative.

No electrical equipment or apparatus may be modified without written authorisation from the nominated project management representative.

Conductive ladders may not be used in proximity to non-insulated electrically energised lines or equipment.

All permanent and temporary electrical cables, whether energised or not, must at all times be handled as if they are energised.

Only appropriately certified intrinsically safe electrical equipment may be used in flammable or potentially explosive atmospheres such as in confined spaces.

Any equipment or structure on which electric charges may accumulate (such as storage tanks) must be grounded (earthed).

Lightning protection must be provided on all tall structures and buildings.

Grounding (earthing) and lightning protection systems and devices must be designed, engineered, selected and installed based on site-specific requirements.

Before carrying out any excavation work, a Permit to Work (specifically authorising the excavation activities) must be obtained from the nominated project management representative. Such a permit must not be issued until it has been verified that no buried hazards or services exist where the excavation work is to be carried out (refer to the Excavation Standard).

16.16.2 Arc Flash Safety

Depending on the scope and nature of the work, a documented arc flash protection programme must be in place that specifies:

- The methodology for calculating incident energies and determining flash protection boundaries; and
- The PPE required (specific to a task and the equipment on which the task is performed) and associated procedures to mitigate the hazard.

The method of calculation must be based on regional electrical code requirements, or if none exist, the Institute of Electrical and Electronics Engineers (IEEE) Standard 1584, or the United States National Fire Protection Association "Standard for Electrical Safety in the Workplace" (NFPA 70E), or published equivalent.

An Arc Flash Hazard Assessment must be carried out based on accurate and current data. All electrical cabinets where the potential for an arc flash hazard exists must be labelled in accordance with the hazard assessment and the potential incident energies calculated.

A process must be in place for updating the Arc Flash Hazard Assessment and labelling as changes and electrical upgrades occur that might affect the available short circuit current on the system.

In order to mitigate the hazard, Safe Work Procedures must be in place and all persons potentially exposed to arc flash hazards must be trained in these Safe Work Procedures and must be supplied with appropriate arc flash PPE.

16.16.3 High Voltage Power Lines

Before any mobile equipment (such as a crane, bulldozer, back-actor, boom truck or drill rig) is mobilised to a work site, an assessment must be carried out (including a thorough inspection of the work site and the access route) in order to clearly identify any overhead or underground power lines.

A system must be in place to mitigate the risks associated with working in close proximity to power lines and suitable measures must be taken to prevent personnel or equipment from coming into contact with power lines. Extreme caution must be exercised.

Where possible, exclusion zones (based on minimum clearance distances specified by the electrical power utility or the nominated project management representative) must be created with rigid barriers and warning signs.

Only in exceptional circumstances, and then only after a detailed method statement and risk assessment has been approved, all necessary mitigation or control measures are in place (including the use of a spotter), and a Permit to Work has been issued by the nominated project management representative, may equipment be operated within one boom length of energised overhead power lines. Suitable protective insulating barriers may need to be used.

If possible, the power lines must be de-energised and isolated while the work is carried out.

All equipment operators and rigging personnel must be trained in the hazards and the applicable safe approach distances (exclusions zones) associated with overhead power lines.

A procedure must be in place for the evacuation of mobile equipment or a vehicle in the event of accidental contact with power lines. All operators must be trained in this procedure and must follow it implicitly.

Scaffolding may not be erected within 5 metres of power lines or overhead track equipment.

16.16.4 Portable Electrical Equipment

Prior to site establishment, each contractor must provide a complete inventory of all portable electrical equipment that he and his sub-contractors intend to use on the site (including plant, machines, appliances, generators, hand tools, lighting, extension cords, etc.). The nameplate data for each item of equipment must be included.

All portable electrical equipment to be used on the site must be supplied and maintained in a serviceable condition.

Any electrical equipment that is in poor condition or is not in proper operating order may not be used. Any electrical equipment that a nominated project management representative deems to be unsafe or unsuitable must be removed from site.

Electrical repair work or diagnostic work on electrical equipment may only be performed by personnel who are competent and authorised to perform this work (i.e. qualified electricians).

With the exception of double-insulated equipment, all electrical equipment must have an equipment grounding (earthing) conductor that connects the frame of the equipment being utilised to the grounding (earthing) conductor of the electricity supply system.

All electrical equipment and all electricity supply systems used (including generators) must be inspected and tested by a registered and competent electrician to ensure that all equipment is properly grounded (earthed).

All electrical equipment used on site must be supplied electricity through (i.e. must be protected by) an approved and tested residual current device (or earth leakage device or unit). If a socket outlet does not have a residual current device in the circuit, a portable residual current device must be used. Outlets without residual current device protection must be labelled as such.

Any electrical equipment that causes an earth leakage device to trip or deactivate the circuit may not be used again until an electrician has inspected and tested the equipment and has recorded in a register that the equipment is safe to use.

Interlocks may never be removed or modified, and fuse terminals may never be bypassed to keep current flowing in any circuit.

All generators must be fitted with suitable overcurrent protective devices (i.e. circuit breakers or fuses).

All generators must be used in compliance with the manufacturer's requirements. Any proposed modification to a generator must be authorised in writing by the manufacturer prior to the modification being made.

Each welding machine used on site must be fitted with a Voltage Reduction Device (VRD). If this is not practical (i.e. for arc welding processes other than stick welding), a dead man's (isolation) switch in the electrode circuit (operated by a trained observer) may be used as an alternative. All welding machines must be properly grounded (earthed).

All portable electrical hand tools used on the site must be double-insulated. Electrical equipment must be disconnected or unplugged when not in use. Portable lights must be stable and each light bulb must be protected by a substantial guard. Temporary festoon lighting must be double-insulated and must be supported at least 2.5 metres above the floor, if possible.

Handheld lights must be of the all-insulated type and must be extra low voltage (i.e. not exceeding 32V). 120V or 240V handheld lights are not permitted. Any lighting used in hazardous locations (i.e. potentially explosive atmospheres, confined spaces, and damp or wet areas) must be operated at a maximum of 32 volts, unless earthed and protected by earth leakage devices. No person may wear a watch or any jewellery, or carry any metal objects such as a lighter or keys, while working on any electrical system or equipment. No person may work on or use electrical equipment if his clothing is wet or any part of his body is in contact with water.

No person may handle electrical equipment, equipment cords or extension cords with wet hands or if the floor or ground surface is wet. Fire extinguishers filled with carbon dioxide must be used to fight electrical equipment fires (water may never be used). If possible, the electrical equipment should be de-energised before fire-fighting activities commence (refer to the Fire Protection and Prevention Standard). When cleaning or performing maintenance work on an item of electrical equipment, the equipment must be unplugged.

Equipment may not be unplugged while that equipment is switched on. Nor may equipment be plugged into a receptacle (socket) with the equipment's switch turned on. Electrical equipment that has a defective plug or wiring may not be used. Repair work to defective or damaged electrical equipment may only be carried out by a qualified electrician. Extension cords may be used for temporary applications only. Permanent cabling must be installed for long-term needs.

Extension cords may not be run through doors, windows, ceilings or holes in walls. An extension cord must be uncoiled completely before it is used. An extension cord must be of sufficient current-carrying capacity to power the equipment that it is supplying electricity to. Cords must not be overloaded. Extension cords must be unbroken and continuous (i.e. no joins or splices in the cord are permitted).

Extension cords may not be daisy-chained (i.e. one extension cord plugged into another extension cord). Extension cords and equipment cords may not be modified to fit a receptacle (socket).

Two-conductor extension cords may not be used. A three-conductor extension cord (i.e. a grounded or earthed cord) must be used even if the equipment that it is supplying electricity to uses a two-prong plug.

Extension cords that are frayed, have insulation tears, cracks or abrasions, have exposed conductors, or have bent, broken or "spread" plug prongs may not be used. Extension cords that will be used outdoors must have heavy duty insulation and must be weather and UV resistant.

All electrical equipment cords and extension cords must be covered or elevated to protect them from damage and to eliminate tripping hazards.

Each contractor is responsible for protecting his electrical equipment from the weather and from possible mechanical damage.

All portable electrical equipment (including generators) must be inspected, tested and tagged by a competent and appropriately qualified electrician on a monthly basis. Details of these inspections and tests must be recorded in a register which must be made available to the nominated project management representative for inspection.

The inspection and testing must include a continuity test of the grounding (earthing) conductor (as applicable) and a complete examination of the equipment or system to assure safe use.

The following colour coding system must be used for the tagging of all electrical equipment:

Table 16-2 Colour Coding System for Electrical Equipment

Month	Tag Colour	Month	Tag Colour
January	Red	July	Red
February	Blue	August	Blue
March	Orange	September	Orange
April	Green	October	Green
May	White	November	White
June	Yellow	December	Yellow

The tag placed on a piece of equipment must be traceable to an entry in a register where the following information concerning the inspection and testing of that piece of equipment must be recorded:

- Date of inspection and testing;
- Equipment description;
- Equipment owner;
- Equipment location;
- Name, signature and licence number of the electrician who carried out the inspection and testing; and
- Comments concerning the inspection and testing, and details of any repair work carried out or required.

Any item of electrical equipment that does not pass an inspection or test must be removed from service (and tagged, "Out of Service") immediately and must then either be repaired (if possible) or removed from site.

Any item of electrical equipment without a tag or with an out-of-date inspection or test may not be used.

Any item of electrical equipment found without a tag or with an out-of-date inspection or test must be removed from service until it has been inspected and tested. If it is found that more than one item of equipment being used by a contractor has not been inspected and tested as required, all work with electrical equipment must be stopped until it can be demonstrated to the satisfaction of the nominated project management representative that the contractor's systems and controls are adequate and fully implemented.

In addition to the formal monthly inspections and testing carried out by an electrician, electrical equipment (particularly extension cords, portable hand tools, welding machines, compressors and pumps) must be visually inspected by the user on a daily basis prior to use. Users must be trained to look for cracks in casings, loose casings, outer cord sheathing that is not being held firmly in position at the equipment, cuts or cracks in cord or cable insulation, exposed conductors, damaged plugs or sockets, and missing covers. Damage and / or defects must be reported immediately.

Personnel must immediately stop using and report any electrical equipment or machinery that is shocking, sparking, overheating or smoking. Corroded outlets, switches and junction boxes must also be reported.

16.17 Confined Spaces

Entry into a confined space occurs when a person's whole body, upper body or head is within the confined space. This is not intended to prevent an authorised, competent person from inserting only his arm into the space to test for hazards using appropriate monitoring equipment. Precautions must be taken to prevent persons from being overcome by atmosphere escaping from the confined space.

Before any person enters a confined space, a detailed risk assessment must be carried out, including the need for an authorised person to assess such things as oxygen levels, contaminants, temperature extremes and concentration of flammable substances.

As a minimum the risk assessment shall address the following:

- Isolation and lockout procedures required for chemical substances, mechanical or electrical energy, steam, pressure, heat, gases, liquids and solids;
- Venting, purging, draining and cleaning prior to entering the confined space;
- Hazards created by carrying out particular tasks or through the use of chemical substances in the confined space. Task-Based (or Issue-Based) Risk Assessments and/or Written Safe Work Procedures must be available for work in confined spaces - in particular for abrasive blasting, welding, flame cutting, grinding, chemical/steam cleaning, rubber lining and painting;
- Entry, exit and escape routes as well as barricading;
- The electrical safety, intrinsic safety and other safety specifications of equipment to be used in the confined space (explosive atmospheres must be considered);
- The need to test for presence of toxic/asphyxiant substances, radioactivity, oxygen, temperature extremes and flammable substances prior to entry and during the performance of work;
- Provision of suitable mechanical ventilation and personal protective equipment e.g. lifejackets etc. and in particular the use of respiratory protection such as compressed air breathing apparatus; and
- A ventilation rate suitable for general use must take into account factors such as air contaminant type, rate of generation, rate of oxygen depletion, temperature,

efficiency of ventilation distribution and contaminant removal from the breathing zone. Therefore each situation needs to be evaluated on its own merit by a risk assessment that will select a combination of ventilation method and respiratory protection that suits the particular circumstances. This must be achieved by consultation between competent operations personnel, engineers and a ventilation specialist.

Entry and work inside a permitted confined space must be controlled and regulated by the project Isolation / Lockout and Permit to Work control systems. The Authorised Person issuing the Permit to Work may only do so if the conditions applying to the specific confined space entry have been satisfied and documented.

As a minimum, the following must be included in the permitting process:

- Access barriers to prevent unauthorised entry;
- Isolation procedures for contaminants and other energy sources;
- The need for breathing apparatus / ventilation requirements;
- The sign-in and sign-out of all persons entering the confined space;
- Display of the permit;
- Communication procedures and/or equipment;
- Safety specifications of equipment to be taken into the confined space;
- Barricading of entrances and exits;
- Rescue plan and equipment;
- Standby person(s); and
- A completion and lock-in procedure (to ensure that space is evacuated and adequately secured).

The Permit to Work process must require competent rescue persons with suitable communication, rescue and firefighting equipment to be present where any of the following may exist:

- Compressed air breathing apparatus is required;
- There is a high risk of fires or explosions;
- The atmosphere can rapidly become unsafe for breathing purposes if the mechanical ventilation fails;
- There is a high risk of flooding or engulfment;
- Narrow tunnels or pipes are entered or where exit or escape routes cannot readily be accessed
- Work is done in remote areas; and
- A single person, who cannot be observed directly or is isolated from other workers, does the work.

Where testing for toxic/asphyxiate substances, radioactivity, oxygen, temperature extremes and other health hazards as well as for flammable substances is carried out, it may only be done by persons trained, tested and certified competent in writing to do so. The ventilation method and quantity must be adequate to ensure oxygen levels and explosive or toxic gas levels remain within acceptable defined limits. Where ventilation is required, this must be covered by an approved documented procedure.

As a minimum standard, the volume of air pumped in and circulated in a confined space needs to be equivalent to 20 times the volume of the space per hour.

Where breathing apparatus or respiratory equipment is required, the contractor's Health and Safety Officer must be consulted with regard to the specification and selection of suitable equipment.

All persons required to use respiratory protection must be medically fit and trained in the correct use of the equipment.

Safe and convenient entry, exit and escape routes from the confined space must be provided where possible and practical. Where this cannot be achieved effectively, the risk assessment must determine if a competent rescue person must be on duty at the confined space when work is in progress.

Where a standby/rescue person is required, they will have no other duties and will be positioned outside the confined space entry point at all times while personnel are within the space.

16.18 Conveyors

The contractor must ensure that no person attempts to cross / climb over or under any conveyor. Instead, a safe passageway (a crossover or an underpass fitted with safeguards) must be used.

No person may climb onto, sit on, stand on, or walk on a conveyor at any time. Riding a conveyor belt is strictly forbidden.

No person may operate a conveyor other than trained, competent and appointed conveyor operators.

Only authorised maintenance personal are permitted to work on conveyors and only if all energy sources have been effectively isolated and locked out and a Permit to Work has been issued by an Authorised Person.

Working on an operational conveyor is strictly prohibited.

No work may be carried out within three metres of an operational conveyor.

16.19 Arc Welding

All welding machines must be fitted with voltage reducers.

The supply cable to every welding machine must be correctly rated and fitted with an approved plug to be used only with an approved matching plug socket.

The electrical circuit to every plug socket must be protected by a correctly rated circuit breaker and a supply voltage rated earth leakage unit.

Welding cables must be properly insulated and correctly rated for the welding machines on which they are to be used.

Welding cable terminals must either be covered with a properly designed, constructed and installed cover so that inadvertent human contact with the terminals is impossible, whether the cables are connected or not, or the welding cables must be fitted with insulated plugs so that inadvertent human contact with any live part is impossible when the cables are plugged into the machine. Also the plug socket should be such that when the cables are not plugged in, inadvertent contact with a live part of the socket is impossible.

Earth cable clamps and electrode holders must be of an approved type. Earth clamps and electrode holders must be fixed to welding cables with eye terminals and bolts.

All welding machines and safety devices must be subjected to regular planned maintenance and a monthly electrical inspection. The inspection must include a test to ensure that the voltage reducer is functioning properly, by measuring and confirming that the open circuit output voltage is reduced.

Before using a welding machine, the welder must ensure that he is wearing all the required and approved protective clothing and equipment:

- Persons assisting the welder must also wear all of the required personal protective Welding hood;
- Leather welding gloves;
- Safety boots with steel toe protection;
- Flame resistant overalls; and
- Any other clothing or equipment necessary to perform his work safely and efficiently.
- equipment.

When changing electrodes or moving the earth clamp, the welder or his helpers must wear gloves to avoid possible skin contact with live electrical parts and to prevent burns. When attaching welding cables to the terminals of the welding machine, the welder or his helpers must wear gloves, or preferably, the machine should be switched off to avoid possible electric shock.

Helpers who may be holding the work piece being welded must wear gloves and protective goggles.

Where practicable the welder should place protective screens around the area where he is welding, to prevent injury to the eyes of passers-by.

The welder must ensure that the earth cable follows the shortest practical route between the welding machine and the work piece. The earth connection must be directly between the welding machine and the work piece and no building or other structure must form part of the earth return path.

As far as is practicable, the welder should avoid welding under wet or damp conditions. If this is unavoidable, the following precautions should be taken:

- Use only oil filled or other watertight type welding machine;
- Keep the electrode holder as dry as is practical;
- Keep as dry as possible. Stand on an elevated surface out of the water and wear watertight boots and a rain suit. Also ensure that the gloves are in good condition, free of holes.
- Under conditions that result in high perspiration levels, the following measures should be implemented:
 - Use an insulated electrode holder;
 - Change clothing regularly (if possible);
 - Use insulated material like rubber mats and/or timber tuck board to separate yourself from the work piece;
 - Wear dry gloves on both hands during welding;
 - Use fans and air-conditioning to reduce humidity and temperature; and
 - Use an observer capable of responding in an emergency.

When working inside metal vessels or under other conditions where parts of his body may come into contact with conducting surfaces, the welder must take precautions to insulate himself from such surfaces.

When working in confined spaces, the welder must take steps to ventilate the area to prevent inhalation of fumes, which may endanger his health and the health of any assistants.

Engine powered welding machines must not be used in any place that is not very well ventilated since the welder and his helpers may be overcome by carbon monoxide fumes.

The welder should take the necessary precautions when welding objects that may catch alight, explode or release poisonous fumes or gases.

16.20 Gas Welding and Burning

Welding or cutting torches and hoses shall not be connected to cylinders when stored. When work is stopped and equipment is unattended, all valves at the gas and oxygen cylinders shall be closed. The hoses shall be bled and a check shall be made later for possible pressure build-up. Torches shall be removed from the hoses prior to putting them into the toolbox. Smoking SHALL NOT be permitted during this stopping procedure.

Special care shall be taken during overhead cutting and welding operations to safeguard and prevent falling sparks from starting a fire.

Warning signs shall be posted around and at each level below the area of each overhead welding or burning operation. Fire extinguishers shall be available and fire blankets shall be used for protection.

When welding or cutting, adequate ventilation must be ensured / provided.

Hoses shall be kept clear from passageways, ladders and stairs. When hoses are subject to damage, they shall be properly protected. Hoses shall be inspected daily.

Fire extinguishers shall be ready for instant use in locations where cutting is performed.

Flash-back arrestors must be fitted to all cutting torches at the torch and at the bottle (a total of four arrestors).

Lighting of the cutting and welding torches must only be done using a striker and not an open flame.

Soap Leak tests must be performed on all flash-back arrestors.

Hoses may only be secured using approved hose clips, and not by wire, cable ties or any other means.

Special care shall be taken when welding with respect to piping that has been painted, as toxic fumes may be emitted in some cases. The supervisor's advice should be sought prior to the above welding operations being carried out.

16.21 Compressed Gas Cylinders

The contractor must establish a suitable storage area for oxygen, acetylene, LPG and argon cylinders in compliance with the following requirements:

- The storage area must be located at least 10 metres away from any building, and must be well ventilated;
- The storage area must have a concrete floor;
- The storage area must be enclosed using wire mesh fencing (as this will ensure adequate ventilation). This enclosure must be kept locked. Access into the storage area must be limited and controlled;
- A protective covering or roof must be fitted to the enclosure to provide shade;

- The enclosure may not be used for the storage of any other materials / equipment, and must be kept completely free of all combustible materials at all times;
- Appropriate warning signage (i.e. "No Smoking" and "No Naked Flames") must be prominently displayed on the enclosure;
- A 9kg dry chemical powder fire extinguisher must be mounted near the entrance to the enclosure
- If electrical lighting is required, it must be of an approved intrinsically safe type;
- Oxygen, acetylene, argon and LPG cylinders must be stored separately in the enclosure. Furthermore, full and empty cylinders must be separated. Separate storage sections must be clearly designated within the enclosure for the different gas types, and for full and empty cylinders, i.e. oxygen – full, oxygen – empty, acetylene – full, acetylene – empty, etc.;
- When a cylinder is empty, the cylinder cap must be replaced to protect the valve. Empty cylinders must be clearly marked (there must be no need to open valves to check if cylinders are full or empty);
- All cylinders must be stored in an upright position and must be secured in this position by chaining, strapping or clamping them individually to a wall, a cylinder trolley, rack or carrier, or some other rigid structure;
- Cylinders must be stored in rows (when necessary due to the number of cylinders) with aisles between the rows to facilitate easy and rapid removal in the event of a fire;
- Oxygen cylinders may never be stored near highly combustible materials, particularly oil and grease, or near fuel gas cylinders. When in storage, oxygen cylinders must be separated from fuel gas (LPG and acetylene) cylinders by a distance of 6 metres or by a 2 metre high wall made of fire-resistant material;
- The total quantity of gases stored on site must be limited to a 2 week supply.

Compressed gas cylinders must always stand upright (i.e. when being used, stored or transported) and must be properly and individually secured to prevent them from falling over.

Cylinders must be protected from flame, heat and from being struck by moving equipment and falling objects.

When handling gas cylinders (whether full or empty), care must be taken to prevent sudden impacts.

Whenever a cylinder is not in use, the protective cap must be in place to prevent the valve from being damaged.

Gas cylinders may not be carried, dragged, rolled or slid across a floor or surface.

When gas cylinders are to be moved / used, they must be placed in a proper cylinder trolley fitted with a 1.5kg dry chemical powder fire extinguisher.

Gas cylinders may not, under any circumstances, be used as rollers or work supports.

If transported by crane, hoist or derrick, compressed gas cylinders must be placed in a suitable cradle, net or skip box. Cylinders may NEVER be lifted using wire rope, fibre rope, a web sling or a chain sling. Before moving / transporting a gas cylinder, the regulator must be removed and the protective valve cap must be replaced.

Gas cylinders may not be taken into a confined space. Gas hoses that are run into a confined space must be removed during breaks.

Gas cylinders may not be placed on scaffolding.

Cylinder valve keys must be in place. If no suitable valve key is available then the cylinder may not be used. Nothing but the manufacturer-supplied key may be used to open the valve.

A flashback arrestor and a check valve (non-return valve) must be installed between the regulator and the hose and between the hose and the torch on the oxygen line and on the fuel (acetylene) line.

Connection fittings may not be forced and safety devices associated with cylinder valves or regulators may not be altered / tampered with.

Gas hoses may not be joined. Only approved hose connectors of the crimp type are permitted. Wire and jubilee clamps are prohibited.

Only high quality ancillary equipment may be used. This includes flashback arrestors, hoses, clamps, spindle keys, nozzles and torches.

Only trained and competent personnel may operate gas welding / cutting equipment and appliances.

When an employee opens the valve to a cylinder, he must stand to one side and open it slowly. Valves may never be left partly open – they must either be closed or be opened fully.

Leaking cylinders must immediately be removed from service and the workplace (if it is safe to do so).

Suitable firefighting equipment must be at hand wherever gas cylinders containing oxygen and / or fuel gas are being used.

Gas cylinders must be prevented from coming into contact with electrical circuits, e.g. welding leads. Never strike an arc on a cylinder.

Oxygen may only be used for the purpose for which it is provided. Do not use oxygen in pneumatic tools or tyres, as an explosion may occur.

Empty cylinders must immediately be marked as such and must be removed to the cylinder storage area at the end of each day / shift.

16.22 Electrically Powered Tools and Equipment

All powered hand tools, such as circular saws, drills, chainsaws, percussion tools, jigsaws etc., must be equipped with a constant pressure switch that will shut off the power when the pressure is released. (Exception: this requirement does not apply to concrete vibrators, concrete breakers, powered tampers, jack hammers, rock drills, and similar hand operated power tools).

Electrical power tools must be of the approved double-insulated type. The electric cord, pneumatic or hydraulic supply line of powered tools must not be used for hoisting or lowering of the tool.

Loose clothing, jewellery or gloves that could get caught in the tool must not be worn when operating powered tools. Operators of powered tools who have long hair must keep their hair tied up.

The power source must be disconnected from the tool before making any repairs, servicing, adjustments, or replacing attachments such as drill bits.

16.22.1 Angle Grinders

The following personal protective equipment must be worn when using angle grinders:

- Safety helmet;
- Gloves;

- Safety glasses (or safety goggles) and a full face shield (i.e. double eye protection);
- Overalls with long sleeves and long pants, avoid any form of loose clothing;
- Safety boots with steel toe protection;
- Hearing protection;
- Breathing apparatus where dust or fumes may be generated;
- Where grinding machines are used, a face shield is to be worn as extra protection to the safety glasses; and
- Certain tasks may require the use of a leather apron as determined by a risk assessment.

A 230mm angle grinder may not be used for free cutting purposes. Exceptions may be approved only if alternative methods evaluated proved more hazardous or no alternative exists. The risk assessment for the task must then specifically include mitigating measures to ensure the safest possible way of performing the task.

The use of 230mm angle grinders for grinding purposes is acceptable, however should this form of grinding be required, the 115mm or 125mm grinders would be preferable. All angle grinders must have a dead man switch incorporated, with a pressure switch in the handle.

A 230mm electrical angle grinder unit must incorporate a soft start to reduce the starting strain and a braking system to reduce run on after the unit has been switched off.

All angle grinders must have a spindle lock to assist with changing the disc or grinding wheel.

Anti-vibration handles are recommended to further reduce the stress if used for extended periods.

Angle grinders must be equipped and operated with disc guarding at all times.

Angle grinder must not be stored with fitted discs, as this will lead to damaging of the discs.

Before use and mounting of discs it is essential to check the safety codes and specifications printed on the upper side of the disc. Such specifications include the following:

- Revolutions per minute (RPM). The allowable speed of the disc must be equal to or greater than the maximum achievable speed of the grinder;
- Physical dimensions of the disc must meet grinder specification; and
- The disc must be suitable for the material type to be cut / ground as indicated on the disk. Cutting discs must never be used for grinding and vice versa.

It is critical that the correct disc mounting procedure is followed:

- Check that the machine is plugged out;
- Check the machine spindle, backup washer and thread;
- Check the condition of spindle nut - ensure spanner drive holes are not elongated;
- Ensure spindle nut spanner is the tool recommended by machine manufacturers;
- Do not use a hammer, pipe or chisel to tighten the nut, or apply additional mechanical advantage to nut torque. A firm "nip" is sufficient to retain the disc;
- Ensure the spindle diameter is suited to disc bore. Excessive clearance will cause the machine to vibrate due to eccentricity;
- Check to see that the nut and backup washer do not "bottom out". This will result in the disc not being correctly clamped on the spindle;

- Ensure the spindle speed is marked on the grinder and that it is less than the allowable disc speed; and
- Fit the disc, with the metal ring or writing to the nut side.

16.23 Pneumatically Powered Tools and Equipment

Pneumatic powered tools must only be driven by filtered compressed air with an in-line lubrication system, or be lubricated prior to use if there is no in-line lubrication system. When using pneumatic powered tools the designated tool pressure must be attained by the use of a regulator.

Pneumatic powered tools must be disconnected when not in use. They must not be disconnected from the air supply until all the residual pressure has been released or contained by a shut-off device. Hoses must not be kinked as a means of containment.

Employees operating pneumatic powered tools, and any potentially affected employee in the vicinity of use, must wear suitable personal protective equipment.

All rotary compressed air tools (e.g. drills) must have the rated revolution per minute (RPM) permanently marked on the casing. Only attachments of compatible RPM must be used with these machines.

The actual RPM of the tool must be checked every three months to ensure that the speed is as rated to manufacture specifications.

Pneumatic powered tools must be secured to the air supply hose by an approved positive means to prevent the tool from becoming accidentally disconnected. Safety clips or retainers must be securely installed and maintained on pneumatic impact (percussion) tools to prevent attachments from being accidentally expelled.

All pneumatically driven nailers, staplers, and other similar equipment provided with automatic fastener feed, which operate at more than 100 kPa pressure at the tool, must have a safety device on the muzzle to prevent the tool from ejecting fasteners unless the muzzle is in contact with the work surface.

Compressed air must not be used for cleaning purposes except where reduced to less than 30 kPa, and then only with effective chip guarding and personal protective equipment in place. The 30 kPa requirement does not apply to concrete form, mill scale and similar cleaning purposes. The use of compressed air for cleaning purposes must be approved by the nominated project management representative. Compressed air must not be pointed at any part of the body or used for cleaning clothing.

Airless spray guns of the type which atomize paints and fluids at high pressures must be equipped with automatic or visible manual safety devices which will prevent pulling of the trigger to prevent release of the paint or fluid until the safety device is manually released. A diffuser nut which will prevent high pressure, high velocity release while the nozzle tip is removed, plus a nozzle tip guard which will prevent the tip from coming into contact with the operator, or other equivalent protection must be provided in lieu of the above.

Abrasive cleaning nozzles must be equipped with an operating valve, which must be held open manually to enable operation. A support must be provided on which the nozzle may be mounted when it is not in use.

16.24 Fuel Powered Tools and Equipment

Fuel powered tools must be shut down and allowed to cool before being refuelled, serviced, or maintained. Fuel must be transported, handled, and stored in approved fuel

containers. Where possible, diesel driven engines must be used in preference to petrol driven engines. All fuel powered tools must be included on the contractor's Equipment Register and the register must be submitted to the nominated project management representative prior to the relevant work commencing.

When fuel powered tools are used in enclosed spaces, the space must be ventilated and the atmosphere monitored to measure toxic gas concentrations. Persons in the space must wear the necessary personal protective equipment. Confined Space Entry clearance may apply. This type of activity must only be undertaken in exceptional circumstances and requires the approval of the nominated project management representative.

16.25 Hydraulically Powered Tools and Equipment

Hydraulic powered tools must use only approved fluid that retains its operating characteristics at the most extreme temperatures to which it will be exposed. The manufacturer's stated safe operating pressures for hoses, valves, pipes, filters and fittings must not be exceeded.

Only manufacturer approved hoses, valves, pipes, filters and fittings must be used.

16.26 Explosive Powered Tools

All operators shall be trained by the contractor.

The contractor shall ascertain that the explosive charges to be used are of the correct strength for the purpose.

Projectiles from explosive powered tools shall NOT be driven into:

- Tile, terracotta, glazed brick, glass, marble, granite, thin slate or other brittle substances;
- High tensile steel, cast iron or steel hardened by heat treatment; or
- Concrete that contains aggregate that will not pass wholly through 25mm mesh screens.

Under no circumstances shall a tool be fired in such a manner as to cause the projectile to fly free.

Suitable safety glasses and hearing protection shall be worn by operators when firing an explosive powered tool.

At all times when a tool is being used, the operator shall display clearly legible signs at or near the place where the tool is in use. Sign should read: WARNING: EXPLOSIVE POWERED TOOL IN USE – KEEP CLEAR.

The operator shall warn all other employees in the vicinity of the area in which the tool is about to be used.

Tools shall never be stored in a loaded state. Cartridges and tools shall be stored separately in lockable containers.

A logbook must be kept of the number of cartridges used and returned.

16.27 Hand Tools

Employees required to use hand tools must receive training relevant to the tool and have their competency assessed in the operation, inspection and maintenance of the tool. Where necessary, additional applicable personal protective equipment must be worn when using hand tools.

Wrenches, including adjustable, pipe, end, and socket wrenches, must not be used when the jaws are sprung to a point where slippage occurs. Impact tools such as drift pins,

wedges and chisels, must be kept free of mushroomed heads. The wooden handles of tools must be kept free of splinters or cracks.

Adjustable wrenches must not be used in lieu of ring or open-end type spanners, unless a risk assessment has been conducted and the use of the adjustable wrench is approved by the nominated project management representative. Wherever possible, ring spanners must be used in preference to open end spanners.

Correct hand tools for the job must be used, e.g. screwdrivers must not be used as chisels, and pliers must not be used as hammers.

All wedges and drifts that may spring, fly or fall to lower levels upon impact must be fitted with an attachment which attaches a safety "lanyard" to a solid structure to restrain the impact tool from becoming a projectile.

All hand tools used in elevated areas, that may be dropped or fall to lower levels must be fitted with safety lanyards and attached to solid structures or in the case of podges, scaffold keys etc., attached by wrist lanyard to the user.

Purpose built tools and equipment may not be used unless a risk assessment has been conducted and authorised by the nominated project management representative.

16.27.1 Stanley Knives / Utility Knives

A utility knife must be used as a last resort, when it is the safest tool to use. Always consider alternatives that pose less of a risk to the operator.

Whenever a utility knife is used, ensure that a complete risk assessment is done and that all possible hazards have been addressed.

Only utility knives with retractable blades are to be used. The blade is to be retracted at all times when the knife is not in use or is being stored.

Before using the utility knife, ensure that the tool is in a good condition and the blade is secure in the holder (seated correctly and that there is no play).

Ensure that the blade is always sharp and in good condition. This will prevent the use of excessive force.

Always wear cut resistant gloves and safety glasses when using a utility knife. There is always a risk of the blade breaking under tension and becoming a projectile.

Always ensure that you cut away from your body, and that no part of your body is in the firing line.

Always ensure cleanliness of all equipment in use during the cutting operations.

16.28 Inspection of Equipment and Tools

All tools must be inspected by the user before, during and after use. If any faults are identified, the tool must be taken out of service and not used until repaired. Faulty tools that are not able to be repaired must be tagged "out of service" and removed from site.

16.29 Manual Handling and Vibration

Any handling or lifting task that can only be done manually must be planned and rehearsed before the task is done.

If more than one person is involved in a task a communication procedure must be agreed in advance. Lowering the load must be done in a controlled manner. Dropping a load is dangerous and must be avoided.

As a guideline 25 kg is considered to be the limit of what a person can safely handle. Where there are loads exceeding 25 kg the risk of handling the load must be mitigated to assure minimal potential for any injury.

When mechanical lifting aids are provided, they should be used.

Extra care should be taken when lifting awkwardly shaped objects.

Position the feet correctly. The feet should be placed hip-width apart to provide a large base. One foot should be put forward and to the side of the object, which gives better balance.

Bend or 'unlock' the knees and crouch to the load. The weight will then be safely taken down the spine and the strong leg muscles will do the work.

Get a firm grip. The roots of the fingers and the palm of the hand should grip the load. This keeps the load under control and permits it to be distributed more evenly.

The following should be considered with conducting the Risk Assessment with regards Manual Handling and also take into consideration the task factors, physical demands and tools involved in the task:

- Load weight/frequency;
- Hand distance from lower back;
- Asymmetrical trunk/load;
- Postural constraints;
- Grip on the load;
- Floor surface;
- Environmental factors;
- Carry distance; and
- Obstacles en route.

Team Manual Handling:

- Load weight;
- Hand distance from lower back;
- Vertical lift region;
- Trunk twisting/sideways bending;
- Postural constraints;
- Grip on the load;
- Floor surface;
- Environmental factors; and
- Communication, co-ordination and control.

As far as possible, exposure to vibration must be eliminated.

However, if this is not possible, short-term solutions to decrease exposure include:

- Reducing the vibration levels;
- Removing the person from the vibrating equipment / tools;
- Reducing the period of time that the person works with the vibrating equipment / tools (at least 40 minutes break after 20 minutes working with a machine that vibrates excessively).

In order to reduce exposure to vibration:

- Consider buying equipment that operates effectively at lower speeds;
- Buy equipment with built-in damping materials;

- Buy lighter tools if they are available - they require less of a grip;
- Maintain the equipment;
- Make sure equipment is balanced and there are no worn parts;
- Use remote controls when they are available;
- Reduce your grip on the equipment when it is safe. The less time you actually have your hands on the equipment the better. Relax your hands during these brief breaks;
- Take scheduled breaks; and
- Do other tasks that allow you to move away from vibrating tools and equipment.

The workplace must be assessed by a competent person for compliance with good design, layout and practice, to avoid or minimise adverse health consequences due to manual handling and vibration issues.

Quantitative evaluations of vibration produced by specific equipment must include the following measurement parameters: direction of movement, frequency, intensity, and variation with time and duration, as per documented methods.

Employees and contractors must be informed of the results of assessments and instructed in appropriate manual handling techniques, where the risk assessment indicates a need. Workplace vibration sources that could contribute to the exceedance of an Occupational Exposure Limit (hence potential for impact on worker musculo-skeletal fitness) must be identified and adequately characterised.

Manual handling tasks assessed as having the potential to cause a Lost Time Injury (i.e. with potential for impact on worker musculo-skeletal fitness) must be identified and adequately characterised.

Workplace manual / materials handling tasks risk rated as "significant" must be assessed and recorded to include biomechanical factors (e.g. posture, bending, twisting, repetitive motions, working overhead, and exerting force away from the body).

16.30 Personal Protective Equipment

All applicable legislation concerning Personal Protective Equipment (PPE) must be complied with at all times.

As a minimum, the following PPE must be worn by all persons (including visitors) at all times whilst on a project site:

- Safety footwear with steel toe protection;
- Safety glasses (individuals who wear prescription spectacles must be provided with either over-spec safety glasses or prescription safety glasses);
- Safety helmet (hard hat); and
- High visibility protective clothing with reflective taping (long trousers and long-sleeved shirts with collars and cuffs).
- Additional PPE requirements must be determined through hazard identification and risk assessment. This hazard-specific PPE (such as hand protection, hearing protection and respiratory protection) must be worn as required (e.g. when in a certain area, when performing a certain task, or when working with a certain substance);
- The correct PPE must always be worn:
- In accordance with site requirements (as indicated at the entrances to a project site and at the entrances to buildings and / or designated areas on the premises);
- In zoned areas (e.g. noise zones and respirator zones); or
- As required by a Safe Work Procedure, a risk assessment, or a Material Safety Data Sheet (MSDS).

Each contractor must provide each of his employees with all required PPE (at no cost to the employee). The specific PPE that is provided to a particular employee must be based on the nature of that employee's work and the location in which the work is performed (i.e. must be based on the hazards to which the employee is exposed). PPE requirements for a particular job or for a particular area must be determined through a risk assessment for that job or area.

Any employee who does not have all of the PPE that is required for him to perform his duties safely will not be permitted to work.

Each employee must care for his PPE, maintain it in good condition, and inspect it on a daily basis.

If an item of PPE has worn out, has become damaged, or is found to be defective in any way, it must be replaced by the contractor.

PPE must be stored in accordance with the manufacturer's requirements and / or recommendations.

Each employee must receive training in the use, maintenance and limitations of the PPE that is provided to him, and must be made aware of why the PPE is necessary as well as the consequences of not wearing it as instructed (i.e. the potential for injury and / or disciplinary action). Training records must be retained.

Any person who refuses to wear PPE as required must be removed from the site. Symbolic signs indicating mandatory PPE requirements must be prominently displayed at the entrances to a project site and at the entrances to buildings and / or designated areas on the premises where additional PPE is required. These signs must comply with the applicable national standard (if one exists).

Each contractor must appoint an employee to:

- Control the issuing and replacement of PPE;
- Keep an up-to-date register as proof that items of PPE have been issued to individuals (an employee must sign for the items that he receives);
- Ensure that there is an adequate supply of all required PPE (i.e. maintain PPE stock levels on site); and
- Carry out regular inspections to ensure that PPE is being used correctly, is being maintained in a good, serviceable and hygienic state, and is not being shared between employees.

Head Protection

A safety helmet (or hard hat) worn correctly will help protect the head in the event of:

- An employee being struck on the head by a falling or flying object;
- An employee striking his head against a fixed or protruding object; or
- Accidental head contact being made with an electrical hazard.

A safety helmet must be worn at all times on a project site, with the following exceptions:

- Vehicle and equipment operators inside enclosed cabs;
- In offices and in office or administration buildings; and
- At designated lunch and break areas (provided that no work is in progress in the immediate break area).

A safety helmet must be worn in accordance with the manufacturer's requirements.

A safety helmet must be worn directly on the head. The wearing of a cap or other headgear beneath a safety helmet is prohibited unless the items have been specifically designed to be used in combination (i.e. the arrangement is approved by the safety helmet manufacturer).

The suspension system inside a safety helmet (that acts as a shock absorber) may not be removed.

The painting of safety helmets is prohibited.

Safety helmets may only be cleaned using a mild detergent and water. No solvents may be used.

16.30.1 Eye Protection

If an employee is carrying out, assisting with, or working adjacent to any activity where sparks or projectile particles are being generated, where chemical mists or fumes are being generated, where liquids may splash or spray, where harmful electromagnetic radiation (heat or light) is being generated, or where there is a risk of wind-blown particles entering the eyes, then suitable protective eyewear must be worn at all times (i.e. safety glasses, safety goggles, a face shield, a welding helmet, or a combination of these).

Such activities include:

- Working with rotating equipment (e.g. grinders, drills, mills, lathes, and saws);
- Welding and cutting;
- Chipping, chiselling or caulking;
- Using explosive powered tools;
- Abrasive blasting;
- Sanding; and
- Working with chemical substances (e.g. drilling fluids, acids, solvents, paints, pesticides, etc.).

For certain activities, special eye protection is required (e.g. a heat-resistant face shield is required when working near molten metal).

Double eye protection is required for activities such as:

- Grinding, cutting, chipping, chasing and reaming (employees must wear both a full face shield and safety glasses or goggles); and
- Arc welding (welders must wear both safety glasses and a welding helmet).

Screens must be erected to protect passers-by, where practical.

Safety glasses must be worn at all times on a project site, with the following exceptions:

- Vehicle and equipment operators inside enclosed cabs with the windows fully closed;
- In offices and in office or administration buildings;
- At designated lunch and break areas (provided that no work is in progress in the immediate break area); and
- When another form of eye protection is required (e.g. safety goggles).

All safety glasses used on site must have suitable permanent side protection.

In strong sunlight, dark safety glasses should be worn to reduce eyestrain and fatigue. However, caution must be exercised when employees are required to frequently move between outdoor and indoor environments. Dark safety glasses may not be worn indoors or in poor daylight conditions. Prescription spectacles with tinted lenses are prohibited inside buildings or other structures with limited illumination unless the lenses are light-sensing and adjust to changing illumination levels.

Employees who wear prescription spectacles (i.e. require corrective lenses) must make use of either:

- Prescription safety glasses (with permanent fixed side shields) that conform to the requirements of a recognised national or international standard (e.g. CSA, ANSI, or equivalent); or
- Over-spec safety glasses or goggles.

The use of contact lenses in certain areas may not be suitable because of increased risk to the eye due to dust or heat.

16.30.2 Hearing Protection

Local regulations concerning occupational exposure to noise and the use of hearing protection must be complied with as a minimum.

“Low noise” tools and machinery must be used wherever possible to reduce noise levels. Where noise cannot be reduced to an acceptable level through engineering and work practice controls, measures must be put in place to minimise the exposure of employees to the noise (i.e. administrative controls and personal hearing protection).

Areas where it is likely that the 95% upper confidence limit of an eight hour L_{eq} mean exceeds 85dB(A), or areas where impulse noise exceeds 140dB(C), must be designated as noise zones. These noise zones must be clearly demarcated and mapped, signs must be posted, and all employees must be made aware of the requirements for working in such an area.

Suitable hearing protection must be worn in all designated noise zones and when carrying out (or working in the vicinity of) any activity where the noise level exceeds 85dB(A).

Where hearing protection is required, a hearing conservation programme (applicable to all personnel and visitors) must be implemented. The programme must include training in the correct use and proper storage of hearing protection devices as well as replacement requirements. Training must be provided when hearing protection is first issued to an employee and refresher training must be carried out at least annually thereafter. Training records must be retained.

At least two types of personal hearing protection must be made available to employees. The hearing protection devices provided must have adequate noise reduction ratings (i.e. must be able to attenuate the noise level to below 85dB(A)).

Personal hearing protection must be issued on an individual basis and must not be shared. In addition to personally issued hearing protection, suitable disposable hearing protection must be made available at the entrances to all noise zones.

All Hearing Protection Devices (except for disposable hearing protection) must be properly inspected and cleaned on a regular basis.

16.30.3 Respiratory Protection

Designated areas (respirator zones) must be established where:

- It is likely that the 95% upper confidence limit of a Similar Exposure Group's mean exposure concentration exceeds the relevant Occupational Exposure Limit (OEL) for agents resulting in chronic effects, such as total inhalable dust, respirable dust, respirable crystalline silica, PAH, fluorides, lead, mercury, asbestos or non-asbestos fibrous materials; or
- The concentration of an agent (particulate, vapour or gas) with an acute effect exceeds 50% of the relevant OEL.

Note: For a particular hazardous agent, the OEL to be adopted must be either the client's OEL or the OEL specified in local legislation, whichever is the most stringent.

These areas must be clearly demarcated and mapped, signs must be posted, and all employees must be made aware of the requirements for working in such an area.

Suitable Respiratory Protection Devices (RPDs) must be worn in all designated respirator zones and when carrying out (or working in the vicinity of) any activity where the risk assessment has identified the need for respiratory protection.

RPD's must be selected based on:

- The type(s) of airborne contaminants that are present (gases, vapours, and particulates and aerosols including dusts, fumes, sprays, mists, and smoke);
- The potential particulate size distribution;
- Substance toxicity; and
- The likely concentrations.

Compatibility with the work tasks and other PPE, comfort (as it affects wear-time), and the ability to communicate adequately, must also be considered.

The risk assessment and method statement for the work to be performed, the information contained in the relevant Material Safety Data Sheets (MSDSs), and the results of any air monitoring associated with the substances to be worked with or activities to be carried out, must be used to ensure that the most suitable RPD is selected.

Only RPDs certified to a recognised standard and approved by the nominated project management representative may be used.

Where respiratory protection is required, a respiratory protection programme (applicable to all personnel and visitors) must be implemented.

The respiratory protection programme must include:

- Periodic inspection of RPDs, including before each use;
- Periodic evaluation (by competent persons) of cleaning, sanitising, maintenance and storage practices;
- Performance of positive pressure and negative pressure fit checks by RPD wearers before each use to ensure that the respirator is functioning properly; and
- Training at first issue of a RPD and regular refresher training thereafter in accordance with regulatory requirements or at least once every two years (the training must cover fit testing, use, cleaning, maintenance, filter cartridge replacement, and storage). Training records must be retained.

RPDs must be used, maintained, and stored in compliance with the manufacturer's requirements as well as the respiratory protection programme.

Suitable facilities must be provided for the cleaning and sanitary storage of RPD's.

As a minimum, qualitative and documented fit testing must be carried out (although quantitative fit testing is preferred) to ensure that the use of negative pressure RPDs (including disposable RPDs) is effective. Fit testing must be performed by a competent person when an RPD is first issued and must be repeated periodically in accordance with legal requirements or every two years as a minimum. A policy must be in place requiring a clean shaven face when using a negative or neutral pressure RPD for routine tasks (otherwise a positive pressure RPD must be used). A medical evaluation including a pulmonary function test may be required to determine whether or not an individual is medically fit to wear a respirator.

For air-supplied RPDs, breathing air must be effectively filtered and / or isolated from plant and instrument air, and isolated from sources of potential contaminants. The supplied air must be tested to determine if the air quality complies with the requirements of applicable standards for breathing air.

For nuisance dust, dust masks with a protection level of at least FFP2 must be worn.

16.30.4 Hand and Arm Protection

Gloves must be worn when handling or working with equipment, materials or substances with the potential to cause injury or illness.

Suitable gloves must be selected based on the task to be performed and the specific hazard against which the employee requires protection, such as:

- Sharp edges;
- Sharp points and splinters;
- Abrasive surfaces;
- Hazardous chemical substances (toxic, corrosive, sensitising, etc.);
- Extreme temperatures; and
- Viruses, bacteria and parasites.

16.30.5 Foot Protection

Safety boots must be worn at all times whilst on a project site, with the exception of offices and office or administration buildings in which closed athletic, business or similar shoes may be worn.

Sandals, slops, slippers, open-toed and high-heeled shoes are not permitted on any project premises.

Safety boots must provide the following protection:

- Steel toe cap to protect against crushing (impact and compression forces);

- Leather uppers that provide resistance against water penetration and water absorption;
- Slip resistant soles;

And where a risk assessment identifies the need:

- Puncture resistant soles (i.e. steel midsoles) for protection against sharp objects;
- Chemical resistant soles for protection against spilt chemical substances (such as solvents, hydrocarbons, acids, and alkalis);
- Heat resistant soles for protection against hot surfaces or molten metal; or
- Electrical shock resistant soles for protection (insulation) against live electrical conductors.
- Gumboots with steel toe caps must be worn when working in water or very wet conditions.

16.30.6 Clothing

All employees working on a project site must wear high visibility protective clothing with reflective taping. Trousers must be long and shirts must be long-sleeved. Shirts must be buttoned at the neck and wrists.

Protective clothing must preferably be made of natural fibres.

Short pants, short-sleeved shirts, sleeveless shirts, and vests are prohibited as outer garments (with the exception of a high visibility vest worn over a long-sleeved shirt).

Loose clothing may not be worn where it may become caught in moving machinery or equipment.

For hot work (e.g. welding, cutting, etc.), work in the vicinity of molten metal, and any work carried out in the vicinity of an open flame, the protective clothing worn (shirt and trousers) must be made of a suitable fire retardant fabric. Underwear and socks must be made of natural fibres (preferably wool) or fire retardant fabric.

No employee may tuck his trousers into his boots when working in the vicinity of molten metal.

16.30.7 Body Protection

Suitable body protection must be provided as required to protect employees against specific hazards. A range of work activities require body protection in one form or another, including but not limited to:

- Working in extremes of temperature, such as firefighting, attending to a heating furnace, working with molten metal, working in refrigerated environments, etc.;
- Hot work (e.g. welding, burning, cutting and grinding);
- Working with hazardous chemical substances (e.g. acids, solvents, pesticides, etc.); and
- Clean up and disposal of hazardous materials and wastes (e.g. asbestos, hydrocarbons, etc.).

A wide variety of protective garments are available, such as firefighting suits, furnace suits, freezer jackets, leather aprons, leather spats, laboratory coats, chemical resistant aprons, chemical resistant (or hazmat) suits, and disposable coveralls. Suitable items must be selected to provide protection against the specific hazard(s) to which an employee is exposed. Hazards must be carefully identified and characterised to ensure that the correct protection is used.

Body protection must be sized properly to prevent tearing, the parting of seams, tripping, or restriction of movement.

16.30.8 Electrical Protective Equipment

To reduce the risk of electric shock, electrical insulating equipment appropriate for the voltage that may be encountered must be worn when working on energised electrical installations and when working within two metres of exposed energised conductors.

All rubber electrical insulating equipment (including gloves, sleeves, matting, covers, blankets, and line hoses) must be inspected for damage prior to and after each use, and immediately following any incident that can reasonably be suspected of having caused damage.

Rubber insulating equipment with any of the following defects and / or damage may not be used:

- A cut, rip, tear, hole, or puncture;
- Ozone cutting or ozone checking (i.e. the cutting action of ozone on rubber under mechanical stress causing a series of interlacing cracks);
- An embedded foreign object;
- Chemical deterioration (texture changes) such as swelling, softening, hardening, or becoming sticky or inelastic; or
- Any other defect that damages the insulating properties.

Rubber insulating gloves must be electrically tested before first issue and every 12 months thereafter as a minimum. Insulating gloves must also be given an air test along with the daily inspection. Essentially, this involves filling a glove with air and checking for any holes or leakage.

Insulating equipment that fails an inspection or electrical test may be repaired only as follows:

- Rubber insulating line hose may be used in shorter lengths with the defective portion(s) cut off;
- A rubber insulating blanket may be repaired using a compatible patch that results in the patched area having electrical and physical properties equal to those of the blanket;
- A rubber insulating blanket may be salvaged by cutting the defective area off the undamaged portion of the blanket;
- Rubber insulating gloves and sleeves with minor physical defects, such as small cuts, tears, or punctures, may be repaired by applying compatible patches. The patched areas must have electrical and physical properties equal to those of the surrounding material.

Repairs to gloves are permitted only in the area between the wrist and the reinforced edge of the opening.

Repaired insulating equipment must be retested before it is put back into use.

Insulating equipment must be cleaned as required to remove foreign substances (using a mild detergent).

Insulating equipment must be stored in such a location and in such a manner so as to protect it from light, temperature extremes, excessive humidity, ozone, and other damaging substances and conditions.

Leather protective gloves must be worn over rubber insulating gloves to provide mechanical protection against cuts, abrasions, and punctures.

Suitable arc flash PPE (e.g. voltage rated gloves, fire retardant clothing, arc rated face shield, arc flash hood, arc flash suit, etc.) must be worn whenever an employee is potentially exposed to an arc flash hazard. The appropriate level of PPE must be worn depending on the task and the potential energy exposure. These PPE requirements must be clearly specified as part of a project-specific arc flash protection programme (refer to the Electrical Safety Standard).

16.30.9 Jewellery

Necklaces, dangling earrings, and bracelets may not be worn on a project site.

No ring or watch may be worn where there is a risk that it may become caught in machinery or equipment.

No jewellery or other conductive apparel (such as a key chain or watch) may be worn when carrying out energised electrical work.

16.30.10 Hair

Scalp hair that is longer than the top of the shoulders must be tied up and restrained within the person's safety helmet or within the collar of his or her overalls, shirt or jacket.

For negative or neutral pressure Respiratory Protection Devices, facial hair must not cause the seal between the respirator and facial skin to be broken (or prevent a seal from being formed in the first place).

16.30.11 Task-Specific PPE

In addition to the standard PPE required for a project site (including a safety helmet, safety glasses, safety boots, and high visibility protective clothing), the following task-specific PPE must be used as a minimum by any person carrying out or assisting with such a task:

- Arc Welding – safety glasses and welding helmet (i.e. double eye protection), respiratory protection against the specific airborne contaminants being generated (fumes, gases, dusts, etc.), leather welding gloves, leather apron, leather spats, leather yoke (for work above shoulder height), and knee pads for welders in kneeling positions;
- Gas Welding, Cutting or Brazing – gas cutting or welding goggles with shade 4 filter lenses and full face shield (i.e. double eye protection), respiratory protection against the specific airborne contaminants being generated (fumes, gases, dusts, etc.), leather gloves (long cuff for welding and cutting, short cuff may be used for brazing), leather apron, leather spats, and leather yoke (for work above shoulder height);
- Grinding – safety glasses or goggles and full face shield (i.e. double eye protection), hearing protection, respiratory protection where dust or fumes may be generated, leather gloves, leather apron, and leather spats;
- Abrasive Blasting – respiratory protection (air-supplied hood), hearing protection, leather gloves, and leather apron;
- Spray Painting – respiratory protection (air-supplied hood for confined spaces), safety goggles (if the respirator design does not provide this protection), hearing protection (where air compressors are used), chemical resistant gloves, and chemical resistant disposable coveralls.

16.31 Sun Protection

The contractor must ensure that all personnel are protected in sunlight through the use of long sleeve shirts, long trousers, brhealth and safety to safety helmets and UV factored sunscreen. Shade structures must also be made available to all employees.

The contractor must conduct training and awareness sessions with his employees, advising on the risks associated with working in the heat (including dehydration) and the precautions to be taken (e.g. ensuring adequate fluid intake).

16.32 Fuel / Flammable Liquid Storage and Refuelling

No fuel (diesel, petrol, paraffin, etc.) or any other flammable liquid (paints, solvents, etc.) may be stored on site unless approved in writing by the nominated project management representative.

If the on-site storage of a fuel or a flammable liquid is approved, the contractor must ensure the following:

- The quantity of fuel / flammable liquid to be stored on site must be kept to the minimum that is required;
- The storage area must be located in a well ventilated area at least 10 metres away from any building, drain, boundary or any combustible material;
- If more than 200 litres of fuel / flammable liquid is to be stored, the tank must be installed / the containers must be positioned within a bund (see Definitions);
- If the fuel / flammable liquid are to be stored in bulk tanks / vessels, then the minimum capacity of the bund must be 110% of the volume of the largest tank / vessel. If many small containers (e.g. 210 litre drums) are to be stored, the bund must be able to contain 25% of the total volume of the stored products;
- The bund must be impermeable. It must have a solid concrete floor and the walls must be constructed out of brick and must be plastered on the inside;
- The bund must be fitted with a lockable drain valve (for draining away rainwater), which must remain locked in the closed position. The valve may only be opened under supervision and in accordance with a written procedure;
- The fuel / flammable liquid storage area may not be used for the storage of any other materials / equipment, and must be kept completely free of all combustible materials (including rubbish, brush and long grass) at all times;
- Access to the storage area must be controlled (wire mesh fencing and gate);
- Appropriate warning signage (i.e. "Flammable Liquid", "No Smoking" and "No Naked Flames") must be prominently displayed at the storage area. The contents and volume of each tank must be indicated;
- In order to contain spillages, the offloading / refuelling bay at the fuel / flammable liquid storage area must have a solid concrete base surrounded by bund walls, ramps or humps and / or spill trenches (covered with steel grating) that lead into a sump;
- Fuel dispensing pumps must be protected against impact damage;
- All fuel / flammable liquid storage tanks and dispensing equipment must be electrically bonded and properly earthed;
- All electrical installations and fittings must be of an approved intrinsically safe type;
- Two 9kg dry chemical powder fire extinguishers must be mounted in an easily accessible position near the entrance gate to the fuel / flammable liquid storage area. Depending on the size of the storage area, additional fire extinguishers may be required to ensure that an extinguisher is no further than 15 metres away from any point on the perimeter of the storage area;

- A fire extinguisher must be at hand wherever refuelling is carried out;
- Smoking or open flames within 10 metres of a fuel / flammable liquid storage / refuelling area is strictly prohibited;
- No petrol or diesel powered vehicle or equipment may be refuelled while the engine / motor is running;
- Cellular phones must be switched off in fuel / flammable liquid storage / refuelling areas;
- Spill clean-up kits (containing a suitable absorbent fibre product) must be provided;
- Any spillages must be cleaned up immediately and all contaminated cleaning materials must be disposed of in accordance with the applicable legislation;
- If a flammable liquid is spilt or is leaking from a container / vessel, the area must be cordoned off and appropriate warning signage must be displayed to keep unauthorised personnel away from the affected area. Every effort must be made to contain the spillage. All hot work in the vicinity must be stopped immediately. If the spilt product is volatile and the possibility exists that a vapour cloud may form, or if the leak or spillage cannot be contained or stopped, then appropriate emergency response procedures must be activated (refer to Section 14) including the evacuation of all persons in the vicinity. Suitable firefighting equipment must be positioned ready for use should the spilt product ignite;
- The manual decanting of fuel or a flammable liquid from a large container should only be done using a stirrup pump (or similar) or a purpose-made frame which allows the container / drum to tilt for decanting and then return to the upright position;
- Drip trays must be used wherever required;
- All tanks, drums, cans, etc. containing flammable liquids must be tightly closed and properly sealed except for when a container is being filled or when a product is being decanted;
- The transport or storage of corrosive or flammable liquids in open containers is strictly prohibited
- Daily-use quantities of fuel (up to a maximum of 20 litres) must be handled in an approved safety can with a flash arresting screen, spring closing lid and spout cover that will safely relieve internal pressure if the can is exposed to fire;
- Where safety cans may be impracticable, only approved metal containers with screw caps may be used. Each container must be clearly labelled to indicate its contents;
- Only small quantities of flammable liquids (paints, solvents, etc.) may be stored within a building. Each product must be kept either in its original container or in an approved container which must be properly sealed. Each container must be clearly labelled to indicate its contents. When not in use, all such containers must be stored in a well-ventilated steel cabinet which must be kept locked to prevent unauthorised access;
- Not even small quantities of flammable liquids may be stored or dispensed in buildings or places of public assembly, in general warehouses, or in buildings containing sources of ignition such as space heaters, cooking devices, open electric motors, motor vehicles, or where welding, cutting, or grinding activities are being carried out;
- Safe Work Procedures must be compiled for the transportation (including delivery), offloading, storage, handling and use of any fuel / flammable liquid on site;
- All personnel that will be required to work with or may come into contact with a flammable liquid must be made aware of the hazards associated with the product

and must be thoroughly trained in the safe transportation, use, handling and storage thereof.

16.33 Fire Protection and Prevention

The contractor must compile a Fire Protection and Prevention Plan for the work that will be carried out on site.

The contractor must assess / survey his area of responsibility and identify locations where the risk of fire is high. Cognisance must be taken of the fact that certain locations may need to be designated as high risk due to the presence of large quantities of flammable or combustible materials / substances. For all high risk areas, the contractor must ensure that additional precautions are taken to prevent fires and strict control is exercised over any hot work (i.e. welding, cutting, grinding, etc.) that is carried out.

The contractor must supply and maintain all required firefighting equipment. The type, capacity, positioning, and number of firefighting appliances must be to the satisfaction of the nominated project management representative and must meet the requirements of the applicable legislation. Fire mains, hydrants and hose reels will rarely be available on site, so use must primarily be made of portable fire extinguishers.

Firefighting equipment, fixed and portable, must be strategically located with a view to being able to rapidly deploy the equipment in order to bring potentially dangerous and destructive fires under control while still in their infancy.

All fire extinguishers (and any other firefighting equipment) placed on site must be:

- Conspicuously numbered;
- Recorded in a register;
- Visually inspected by a competent person on a monthly basis (the results of each inspection must be recorded in the register and the competent person must sign off on the entries made); and
- Inspected and serviced by an accredited service provider every six months (the nominated project management representative may require that this frequency be increased depending on the environmental conditions (e.g. high dust levels, water, heat, etc.) to which the fire extinguishers are exposed).

Any fire extinguisher that has a broken seal, has depressurised, or shows any sign of damage must be sent to an accredited service provider for repair and / or recharging. Details must be recorded in the register.

Firefighting equipment may not be used for any purpose other than fighting fires. Disciplinary action must be taken against any person who misuses or wilfully damages any firefighting equipment.

Access to firefighting equipment, fixed or portable, must be kept unobstructed at all times. Approved signage must be in place to clearly indicate the location of each permanently mounted fire extinguisher, fire hose reel, etc.

The contractor must ensure that all persons working in / entering his area of responsibility are made aware of where all firefighting appliances and alarm points are located.

The contractor must ensure that his employees (and those of any appointed sub-contractors) are trained in firefighting procedures and the use of firefighting equipment.

The contractor must compile an emergency response procedure detailing the actions that must be taken in the event of a fire or a fire / evacuation alarm (see Section 14).

All personnel working within the contractor's area of responsibility must be trained, and all visitors must be instructed, on this procedure. Copies of the procedure must be prominently displayed in the workplace in all languages commonly used on the site.

A person discovering a fire must extinguish the fire if he can do so safely, and then immediately report the incident to his supervisor. If the person cannot extinguish the fire, he must raise the nearest alarm and then report the fire as quickly as possible to his supervisor, the person responsible for the area, and / or Security.

On hearing a fire / evacuation alarm, all persons must make any operational plant or equipment safe, and then proceed to the nearest emergency assembly point and await instructions.

All incidents of fire (including the use or misuse of any firefighting equipment) must be reported to the nominated project management representative immediately. Used fire extinguishers must be replaced by the contractor without delay.

No hot work (i.e. welding, cutting, grinding, etc.) or any other activity that could give rise to a fire may be performed outside of a designated workshop without a Permit to Work having been issued.

Wherever hot work is being carried out, a fire extinguisher must be at hand. Where the risk assessment determines that it is necessary, a fire watch must be stationed.

Supervisors must carry out workplace inspections regularly to ensure adherence to fire prevention measures and procedures.

At the end of every working period (i.e. before each tea / lunch break and at the end of every shift / day), the workplace must be thoroughly inspected to ensure that no material is left smouldering and no condition / situation exists that could give rise to a fire.

The contractor must ensure that all supervisors and all employees carrying out or assisting with any hot work or any other activity that could give rise to a fire have been trained in firefighting procedures and the use of firefighting equipment. The training must be conducted by an accredited training provider.

When using electrical equipment, all cables must be in good condition and the nearest convenient socket must be used.

No power socket may be loaded beyond its rated capacity through the use of adaptors, etc.

Makeshift electrical connections are not permitted under any circumstances.

Water-based firefighting equipment must not be used on electrical equipment or burning liquids.

Refer to Section 13.16 – Electrical Safety.

Each vehicle used on site for work purposes and each item of mobile equipment with a diesel or petrol engine must be fitted with a permanently mounted fire extinguisher.

Smoking is only permitted in designated smoking areas. Cigarette ends / butts must be properly stubbed out in the ashtrays provided and never thrown into waste bins.

The contractor must ensure that good housekeeping practices are enforced, as this is crucial to the prevention of fires.

All combustible waste materials must be removed from the workplace on a daily basis (at the end of each shift) and placed in waste receptacles located at least 5 metres away from any structure.

The accumulation of waste materials in out-of-the-way places is prohibited.

Offices, desks, cabinets, etc. must always be kept tidy and uncluttered. Waste paper bins must be emptied regularly.

The storage of combustible materials under stairways or in attics is prohibited.

The storage of any materials against the exterior of a building or any other structure is prohibited.

All walkways, passages and stairways must be kept clear (i.e. must be unobstructed) at all times, as they may need to be used as a means of escape.

The areas around and the routes to all exits, fire escape doors, fire hydrants, fire hose reels and fire extinguishers must be kept clear (i.e. must be unobstructed) at all times.

"No Smoking" signs must be conspicuously displayed in and around all storage areas / rooms.

Waste may not be burned under any circumstances.

No flammable liquid (such as petrol, acetone, alcohol, benzene, etc.) may be used for starting fires or as a solvent for cleaning clothes, tools, equipment, etc. Only solvents approved by the nominated project management representative may be used for cleaning purposes.

Whenever any work is carried out involving the use of a flammable substance / material, the area must be cordoned off and appropriate warning signage (i.e. "No Unauthorised Entry", "No Smoking" and "No Naked Flames") must be displayed.

Refer to Section 13.32 – Fuel / Flammable Liquid Storage and Refuelling.

16.34 Smoking

The contractor must not permit smoking on site except within designated smoking areas selected in accordance with the applicable legislation. Such an area must be clearly demarcated and the required signage must be displayed.

Any person found smoking or discarding a cigarette butt outside of a designated smoking area may be removed (temporarily or permanently) from site.

In all designated smoking areas, adequate non-combustible commercial ashtrays and / or cigarette butt receptacles (butt cans) must be provided.

Ashtrays and other receptacles provided for the disposal of smoking materials must not be emptied into rubbish bins or any other container holding combustible materials.

"No Smoking" signs must be strictly observed.

16.35 Housekeeping

The contractor must maintain all work areas in a tidy state, free of debris and rubbish. Unless directed otherwise, the contractor must dispose of all debris, rubbish, spoil and hazardous waste off site in a designated and authorised area or facility. The contractor must familiarise himself with the waste management plan for the site including collection and disposal arrangements, and must align his waste management activities accordingly.

In cases where an inadequate standard of housekeeping has developed and compromised safety and cleanliness, a nominated project management representative may instruct the contractor to cease work until the area has been tidied up and made safe.

Neither additional costs nor contract deadline extensions will be allowed as a result of such a stoppage. Failure to comply will result in a clean-up being arranged through another service provider at the cost of the non-complying contractor.

The contractor must carry out housekeeping inspections on a weekly basis to ensure maintenance of satisfactory standards. The contractor must document the results of each inspection. These records must be maintained and must be made available to the nominated project management representative on request.

The contractor must implement a housekeeping plan for the duration of the contract ensuring that the site housekeeping is maintained. Furthermore, at the end of every shift, the contractor must ensure that all work areas are cleaned, all tools and equipment are properly stored, and construction rubble is removed.

Where the contractor fails to maintain housekeeping standards, the nominated project management representative may instruct the contractor to appoint a dedicated housekeeping team for the duration of the project at the contractor's expense.

Littering is prohibited.

16.36 Waste Management

Waste may not be disposed of unless the disposal of that waste is authorised by law. The contractor must therefore ensure that all waste that is generated is handled, stored, transported and disposed of in accordance with the requirements of the applicable legislation / local authority.

No waste may be removed from the project site to a waste storage or disposal facility unless that facility has been approved for use by the nominated project management representative.

An adequate number of waste bins and skips must be provided by the contractor and suitable arrangements must be made to ensure that these bins and skips are emptied regularly.

Hazardous wastes must be kept separate from general wastes.

Waste disposal service providers must be approved by the nominated project management representative before any waste is removed from site. These service providers must be audited on a two-yearly basis (or more frequently if deemed necessary based on risk) in order to ensure compliance with legislation and to help ensure that no liabilities accrue to the project.

16.37 Stacking and Storage

All irregular shaped items will be stacked at floor / ground level in designated stacking areas on a level, firm base capable of withstanding the weight of the commodities being stacked and stacked in such a manner that the items do not topple over or change position due to subsidence or weight transfer when being moved.

Where these commodities are stacked on shelves or racks, the shelves or racks must be designed to carry the weight of the commodity being stacked.

All racks or shelves where heavy material or commodities are stacked will have a weight carrying limitation clearly marked on the structure and have a safety factor of at least +10% of maximum total carrying capacity.

All materials, commodities or articles, which could be damaged due to inclement weather, must be stored under cover.

Waste material that is combustible must not be allowed to accumulate in sufficient quantities to create a hazard.

No commodities or equipment may be stacked or stored within 500mm of rolling stock tracks or where mobile equipment travels.

The storage of material, small equipment, tools, files and general items in cupboards and on shelves must be neat and controlled at all times. Incompatible substances must not be stored in or on the same cupboard or shelf.

No equipment, tools, files or documents may be stored or stacked on top of cupboards which are higher than 1.5 metres in height.

16.38 Demarcation

No demarcation of floors is required inside offices, training centres and the like.

Where it is impractical to paint floors, yellow lines will be deemed adequate e.g. where heavy traffic necessitates the continual painting of floors.

Temporary demarcation in the form of hazard tape (red and white) may be used to demarcate areas where there is, for relatively simple reasons, restricted access.

Where hazards exist and entry must be specifically excluded for safety or health reasons, hazard tape in any form must not be used in isolation. A robust and substantial barrier of timber, rope or other material must be used in conjunction with barrier tape, to prevent entry to unauthorised persons.

Outside storage areas where it is impractical to use floor demarcation, demarcation may take the form of creosote poles and wire rope or similar. Spans between uprights should be painted yellow.

16.39 Facilities

Sanitary conveniences must be provided and maintained at a rate of at least one shower facility for every 30 workers, at least one toilet facility for every 20 workers, separate male and female changing facilities and sheltered eating areas. (Check SANS 10400 Part F).

Where chemical toilets are provided, one toilet for every twenty five employees must be allocated.

All toilets must be cleaned daily, disinfected and provided with toilet paper.

All employees making use of these facilities have the responsibility to help keep the facilities neat, clean and hygienic.

Washing facilities, including soap and towels, must be made available for use by the contractor's employees.

Drainage from all washing / toilet facilities must be properly designed and constructed to prevent employee exposure to waste water (and the associated biological hazards). Waste water may not accumulate or stand in pools at any location on the project site.

Change rooms must be provided and must be kept clean and free from odours at all times. No chemicals, except those normally used for domestic cleaning of these facilities, may be stored in the facilities.

No equipment or items (other than those normally associated with hygiene facilities) may be stored in the facilities.

All entrances must be constructed in a way to afford privacy to users.
Drinking water must be provided.

A sheltered (covered) area must be set aside on site to be used as a dining facility (eating area). Adequate seating must be provided for the maximum number of employees. The facility must be kept clean and tidy.

A suitably sized, impervious receptacle (bin) must be provided for the disposal of waste food and other refuse generated at the dining facility. This bin must be emptied and cleaned regularly (i.e. promptly after meal times).

Food may only be consumed in authorised sheltered areas.

Adequate refrigerated storage must be provided to the contractor's employees for the storage of food and drinks. Fridges must not be overstocked and must maintain sufficiently low temperatures.

16.40 Occupational Hygiene

The contractor must ensure that the exposure or potential exposure of his employees to any of the following stressors is assessed and measured (a baseline survey must be carried out by an Approved Inspection Authority - this services to be provided by TCP):

- Noise;
- Thermal stress (heat and cold);
- Particulates (dust);
- Silica (free crystalline silica);
- Asbestos;
- Gases or vapours;
- Lead;
- Chemicals;
- Ionising radiation;
- Non-ionising radiation;
- Vibration (hand / arm vibration and whole body vibration);
- Ergonomics; and
- Illumination.

If it is determined that exposure levels for a particular stressor are unacceptable, then a monitoring and control plan must be implemented to manage any risk of overexposure.

Note: Where chemical substances are to be used as part of the construction process, the contractor must ensure that the chemical composition of each substance is known.

Carcinogenic (cancer-causing) ingredients must be specifically identified with due understanding that no chemical known to cause cancer will be permitted for use on site (an alternative will need to be sourced).

16.41 Lighting

For all work areas and access ways, if the natural lighting available is inadequate it must be supplemented by artificial lighting to meet the minimum levels required.

A lighting survey to determine luminance must be conducted for all work areas, at least once every two years and prior to work commencing for the first time in any area.

Emergency lighting must be provided in all indoor workplaces that do have adequate natural lighting or in which persons work at night. The emergency sources of lighting that are provided must be such that, when activated, an illuminance of not less than 0.3 lux is obtained at floor level, to enable employees to evacuate safely.

Where it is necessary to stop machinery or shut down plant or processes before evacuating the workplace, or where dangerous materials are present or dangerous processes are carried out, the illuminance must be not less than 20 lux.

Windows and translucent sheeting must be kept adequately clean and clear of obstructions as far as reasonably practicable. Light fittings, i.e. lenses and reflectors must be kept clean.

If a light intensity meter is used, a valid calibration certificate must be available.

Neon lights must not be installed in areas where moving parts of machinery or equipment cannot be fully guarded, i.e. lathes, bench grinders, etc. in order to eliminate the stroboscopic effect.

No person may use a portable electrical light where the operating voltage exceeds 50 volts, unless:

- It is fitted with a non-hygroscopic, non-conducting handle;
- All metal parts which may become live are protected against accidental contact;
- The lamp is protected by means of a guard firmly attached to the handle; and
- The cable can withstand rough use.

No person may use a portable electric light in damp or wet conditions or in closely confined spaces, inside metal vessels or when in contact with large masses of metal, unless:

- The lamp is connected to a source incorporating an earth leakage; and
- The operating voltage of the lamp does not exceed 50 volts. Hearing Conservation

A hearing conservation program must be implemented and protection against the effects of noise exposure must be provided when the noise exposures equal or exceed an 8-hour time-weighted average sound level of 85 decibels measured on the A-weighted scale of a standard sound level meter at slow response.

For the hearing conservation program to be effective it must include as a minimum:

- Monitoring of the workplace to determine the representative exposure of employees to excessive noise levels;
- An audiometric testing program for employees, which must include:
 - ♦ A baseline audiogram for all employees exposed to noise levels equal to or in excess of the standard;
 - ♦ Annual audiograms for each overexposed employee;
 - ♦ Analysis of audiogram results with retesting and/or referral to an otolaryngologist or qualified physician when a significant threshold shift (STS) occurs; and
 - ♦ Written employee notification of the STS.
- A training program for all employees exposed to noise;
- Provision of personal protective equipment to all affected employees when administrative or engineering controls fail to reduce sound levels to within the levels of the standards.

Monitoring of employee exposures to noise shall be conducted by an Approved inspection Authority.

The monitoring requirement may be met by either area monitoring or personal monitoring that is representative of employee exposures. Personal monitoring is preferred, and may be required based on the type(s) of noise sources.

For purposes of the hearing conservation program, employee noise exposures shall be computed in accordance with local legislation.

A person-task specification shall be available for every job category and shall be submitted with an employee for audiometric testing.

Audiometric testing and an annual audiogram shall be provided as part of the regular medical examinations.

Audiometric test results obtained from the pre-employment medical examination for a new employee shall be used as the baseline audiogram.

Testing to establish a baseline audiogram shall be preceded by at least 14 hours without exposure to workplace noise.

Hearing protectors shall not be used as a substitute for the requirement that baseline audiograms be preceded by 14 hours without exposure to workplace noise.

Employees shall be notified of the need to avoid high levels of non-occupational noise exposure during this 14-hour period.

Record-keeping for the audiogram shall include:

- Name and job classification of the employee;
- Date of the audiogram;
- The examiner's name;
- Date of the last acoustic or exhaustive calibration of the audiometer;
- Employee's most recent noise exposure assessment.

Audiometric test results shall be maintained in the employee's medical file.

To control noise exposure, its three basic elements shall be examined, i.e. source of the sound, travel path, and effect on receiver or listener. Solution of a given noise problem might require alteration or modification of any or all of these three basic elements.

2) Controlling noise at the noise source can be achieved by the following:

- Select quiet equipment initially. In selecting quiet equipment the following features shall be considered:
 - Low-noise certification;
 - Advertisement of "quiet" operation, evidence of noise control design;
 - Evidence of "lower" and "slower" operating characteristics;
 - Side-by-side noise testing of equipment; and
 - "On-site" or "in operation" inspection of mechanical equipment before purchase.
- Reduce operating noise by considering the following control measures:
 - Reduce impact or impulse noise by reducing weight, size, or height of fall of impacting mass;
 - Reduce speed in machines and flow velocities and pressure in fluid systems;
 - Balance rotating parts – to control machinery noise and vibration of fans, fly wheels, pulleys, cams, etc.
 - Reduce frictional resistance between rotating, sliding or moving parts in mechanical systems: frequent lubrication, proper alignment of moving parts; static and dynamic balancing of rotating parts; correction of eccentricity or "out-of-roundness" of wheels, gears, rollers, pulley, etc.;
 - Reduce resistance in air or fluid systems: use of low flow velocities, smooth boundary surfaces of duct or pipe systems, and long-radius turns and flared sections in pipes, etc., to reduce turbulence noise;

- Isolate vibration elements in machinery; install motors, pumps, etc. on most massive part of machine; use belt or roller drives in place of gear trains; use flexible hoses and wiring instead of rigid piping and stiff wiring, etc.
- Apply vibration damping materials such as liquid mastic; pads of rubber, felt, foam or fibrous blankets; or sheet metal visco-elastic laminates or composites to vibrating machine surfaces; and;
- Reduce noise leakage from the interior of machines such as compressors by sealing or covering all openings or applying acoustical materials to machine interiors.

3) Controlling noise in the transmission path can be achieved by the following:

- Separate the noise source and receiver as much as possible;
- Use sound-absorbing materials on ceiling, floor or wall surfaces as close to the machine as possible;
- Use sound barriers and deflectors in the noise path;
- Use acoustical lining on inside surfaces of such passageways as ducts, pipe chases, or electrical channels;
- Use mufflers, silencers or snubbers on all gasoline or diesel engines, regardless of size; and particularly on equipment when large quantities of high-pressure, high-velocity gases, liquids, steam or air are discharged into the open air; and
- Use vibration isolators and flexible couplers where the noise transmission path is structure borne in character.

4) Protection for the receiver – when engineering controls fail to reduce the levels to within the levels specified in local legislation, the following measures shall be implemented:

- Personal protective equipment shall be provided and replaced as necessary at no cost to employees;
- Supervisors shall ensure that hearing protective devices are worn by all employees who are exposed to a time-weighted average of 85 decibels or greater and who have experienced a significant threshold shift;
- Employees shall be given the opportunity to select their hearing protectors from a variety of suitable protectors; and

Noise zones shall be indicated by means of signs at every entrance to such zones.

When noise levels exceed 100 dB(A), a combination of earplug and earmuff may be required to achieve protection of the worker.

It is important to note that using double protection will add only 5 to 10 dB of extra attenuation above that of a single Hearing Protection Device.

Where an earmuff and earplugs are used together, OSHA recommends using this simple calculation: Take the higher rating of the two devices, and add five.

Hearing Protection Devices should be worn for the full noise exposure period.

Where an audiometry programme is required, it must meet the following standards:

- All testing must be by pure tone audiometry in an audiometry booth or quiet room, with measured noise levels less than 40 dB(A);
- The initial audiogram must be taken prior (minimum of 24 hours) to exposure to significant noise. Further audiograms must be taken periodically; annually where exposures are over 85 dB(A) Leq or where continued deterioration to hearing is occurring;
- Testing must be performed by trained and competent personnel;

- Audiometers must be calibrated according to the manufacturer's guidelines. As a minimum these will be a weekly biological calibration using an employee unexposed to noise, or a bio-acoustic simulator, and an annual quantitative check. All results must be documented; and
- Audiograms must be read by trained persons who will identify any increasing hearing loss and then determine if this is noise induced. Any employee with a significant downward shift in one or both ears (measured as an average non age-adjusted loss from baseline of 10 dB at 2, 3 or 4 kHz) must be retested following removal from noise for a minimum of 24 hours, usually after a days-off period. If the downward shift persists the employee must be reviewed by a physician and improved hearing protection considered.

16.42 Particulate and Gas / Vapour Exposures

Designated areas must be created where:

- It is likely that the 95 per cent upper confidence limit of a Specific Exposure Group's (SEG) mean exposure concentration for agents resulting in chronic effects (such as total inhalable dust, respirable dust, respirable crystalline silica, PAH, fluorides, lead, mercury, asbestos or non-asbestos fibrous materials) exceeds the relevant OEL; and
- Agents with an acute effect, such as particulate hazards, or gases (e.g. CO, SO₂, NH₃, HF, etc.), or vapours exceed 50 per cent of the relevant OEL.

Designated areas must:

- Be identified and mapped, signposted or otherwise clearly communicated to employees working in the area. Signposting, where necessary, must use appropriate wording or symbols on signs to identify the hazard;
- Have a documented respiratory protection programme based on suitable risk assessment and standards, which is applied to employees, contractors and visitors;
- Have regular monitoring of SEGs working in the area; and
- Have a formal review of the practicality of engineering controls at least every two years, or less where it is a critical control for a significant risk.

Particulate and gas / vapour monitoring must be appropriate to the exposure conditions and toxicants, and based on the use of equipment approved by local regulatory authorities, as per documented methods.

Where risk assessment indicates the possible presence of levels of gas or vapour sufficient to cause health effects in less than one shift (e.g. confined space entry), continuous monitoring is required as long as the potential for harm exists.

Employees and contractors must be covered by a medical surveillance programme when:

- Their Specific Exposure Group TWA mean exposure to respirable crystalline silica, total inhalable dust, respirable dust, lead or asbestos is greater than 50 per cent of the relevant OEL;
- The medical adviser considers that it is advisable; or
- There is a legal requirement for medical monitoring.

Where risk assessment indicates a risk of a respiratory condition, assessment programmes must include chest x-rays and / or lung function tests. The test or tests chosen must enable the earliest detection of adverse effects from the exposure of concern. Where indicated, they must meet the following standards:

- High quality chest x-rays will be taken every five years, unless local legislation requires these to be more frequent;

- All chest x-rays for pneumoconiosis surveillance will be read to International Labour Organisation (ILO) standards by an ILO B reader, wherever possible, and if not, by a competent radiologist using verifiable quality criteria;
- Any progression of more than one step on the ILO extended scheme to a reading above 1/0 will be reviewed by a physician;
- Any reading suggesting active lung disease will be reviewed by a physician; and
- All spirometry will be performed by trained staff following the American Thoracic Society guidelines or equivalent and be offered at a frequency determined by the likely rate of detectable change in lung function.

Controls must be of an adequate standard such that surfaces are adequately cleaned to avoid:

- Dust generation due to material dislodgment (e.g. windblown), where practicable; or
- Fume generation from accumulated dust during welding / heating or cutting operations.

Where risk assessment indicates the need to reduce exposures to toxic substances for employees or their families, good personal hygiene must be enforced. The programme must include:

- No smoking, eating or drinking in designated hazard areas;
- Washing of hands and face prior to drinking, eating or smoking;
- Showering at work post shift or after exposure to 'dirty' conditions; and
- Laundering of contaminated clothing by the contractor.

Abrasive blast cleaning must be conducted so as to protect worker health and minimise dust emissions. Substitutes must be used whenever practicable for abrasives containing crystalline silica. However, if such abrasives are used, workers must be aware of the hazards and exposure monitoring conducted. The hazardous properties of alternative materials must be considered before use.

Where required, training in the recognition of signs and symptoms of hazardous particulate and gas / vapour exposure, emergency procedures and preventative measures must be provided.

16.42.1 Respiratory Protection Devices

The selection of Respiratory Protection Devices (RPD's) must be based on:

- The potential particulate size distribution, gas / vapour types, substance toxicity and likely concentrations;
- Compatibility with the work tasks and other PPE; and
- Comfort (as it affects wear-time) and allowance for adequate communication.

Only RPD's approved by the nominated project management representative may be used. Suitable facilities must be available for cleaning and sanitary storage of RPD's.

Half-mask and full-face air-purifying respirators must NOT be used where:

- The atmosphere is oxygen deficient (< 19.5 per cent);
- The atmosphere is immediately dangerous to life or health (e.g. in areas where CO concentrations are > 1500 ppm, HF > 30 ppm or NH₄ > 300 ppm);
- Gases and vapours are more than ten times their OEL or greater than 1000 ppm for half-mask respirators, or more than 100 times their OEL for full-face respirators; or

- Particulates are more than five times their OEL for half-mask respirators, or more than 50 times their OEL for full-face respirators.

For atmospheres that are oxygen deficient, or contain unknown hazards, or have concentrations of gases and vapours that are unknown, or could potentially exceed levels that are immediately dangerous to life or health, an air-supplied type respirator must be worn.

For effective use of negative pressure RPD's (including disposable RPD's), fit testing must be qualitative and documented as a minimum, although quantitative fit testing is preferred. Fit testing must be performed by a competent person when RPD's are first issued and must be repeated periodically according to legal requirements or two-yearly as a minimum frequency. There must be a policy requiring a clean shaven face when using a negative or neutral pressure RPD for routine tasks, or the use of a positive pressure RPD will be required. A pulmonary function test and medical evaluation may be required to determine whether or not an individual is medically fit to wear a respirator.

For air-supplied RPD's, breathing air must be effectively filtered and / or isolated from plant and instrument air, and isolated from sources of potential contaminants. The quality of the breathing air must be checked for conformance with applicable standards.

The respiratory protection programme must include:

- Periodic inspection of RPD's, including before each use;
- Periodic evaluation of cleaning, sanitising, maintenance and storage practices by competent persons;
- Performance of positive and negative fit checks before each use by RPD wearers to ensure that the respirator is functioning properly; and
- Training at first issue of a RPD and regular refresher training thereafter in accordance with regulatory requirements or at least once every two years.

16.42.2 Asbestos and Non-asbestos Fibrous Silicates

This section applies to asbestos and bio-persistent non-asbestos fibrous silicates that may display asbestos-like toxicity, related to fibre diameter and length. Local regulations must be followed as a minimum. The following requirements must be met:

- A management program must be in place and actively pursued;
- No new products containing these materials may be purchased;
- Installed materials of this type must be identified and assessed annually for current safety. Where 'safe in place', it should not be removed, unless there is an opportunity for removal during renovation or construction of buildings or equipment;
- Work areas must be barricaded off and signposted to restrict entry; and
- Contaminated material must be promptly placed in appropriate marked plastic disposal bags or covered containers for disposal to an approved landfill.

All workers exposed to these materials must be on a register. "Exposed" means working on or near such material that has been disturbed, abraded or cut. The register must contain details of their annual medical examination and the results of occupational hygiene monitoring.

Asbestos contractors must be competent, registered and have adequate equipment, procedures and monitoring.

Where required, the asbestos / bio-persistent non-asbestos fibrous silicates management programme must cover work practices, training, monitoring, medical surveillance, and waste handling and disposal.

Maintenance operations must be made aware of potential cristobalite exposure hazards when disturbing non-asbestos fibrous silicates that have undergone high temperature conditions.

The potential for occurrence of naturally occurring asbestiform materials in exploration or mining production activities must be assessed, the risk of exposure determined and appropriate control measures implemented where required.

16.43 Hazardous Chemical Substances

No chemical substance may be brought onto site unless it has been approved for use by the nominated project management representative and it appears on the Approved Chemical Substances Register which will be made available to all contractors.

The register will contain the following information:

- Trade name / product name of substance;
- Manufacturer / supplier of substance;
- Maximum inventory;
- Storage requirements and precautions;
- Inventory of special emergency items held for handling spillages, fires, etc. (e.g. reagents to neutralise spillages, firefighting foam, etc.); and
- Approved disposal methods.

If the contractor wishes to make use of a chemical substance that does not appear on the register, then the contractor must provide the following information to the nominated project management representative for review PRIOR to bringing the substance onto site:

- A detailed 16-point Material Safety Data Sheet (MSDS) issued by the manufacturer / supplier of the substance;
- The reason for wanting to bring the substance onto site (i.e. the intended use of the substance);
- The proposed method of transportation;
- The proposed arrangements for the safe storage of the substance;
- The quantity to be stored on site;
- The proposed methods for handling / using the substance (including PPE);
- The proposed method of disposal of the waste;
- Proof that the contractor is able to readily provide the necessary first aid measures as specified in the MSDS; and
- A risk assessment covering the transportation, use, handling, storage and disposal of the substance with specific reference to the substance's compatibility with other chemicals.

This information must be provided at least five (5) working days prior to the date on which the contractor intends to bring the substance onto site for use.

Any chemical substance brought onto site without adherence to the requirements stipulated above shall be removed from site immediately.

If the nominated project management representative approves the substance for use, the contractor must ensure that all necessary precautions are taken concerning the transportation, use, handling, storage and disposal of the substance, and that all required PPE and first aid materials / equipment (as stipulated in the MSDS) are readily available on site.

The contractor must ensure that a Material Safety Data Sheet (MSDS) is obtained for each chemical substance brought onto site. A file, or files, containing all of the MSDS's must be maintained and must be readily available to all personnel on site (particularly first aiders) as well as other potentially affected parties (e.g. emergency services personnel, persons from the local community, etc.). The MSDS's must be in the language(s) commonly used on site.

The contractor must appoint a trained and competent Hazardous Chemical Substances Coordinator who understands and is able to evaluate the risks associated with a wide variety of substances. This person shall be responsible for:

- Assessing the hazardous properties and risks associated with all chemical substances brought onto site by the contractor and appointed sub-contractors (using the MSDS's);
- Determining precautions and safe practices for transportation, use, handling, storage and disposal (including PPE requirements) (using the MSDS's);
- Determining first aid and emergency response requirements / procedures (using the MSDS's);
- Maintaining the MSDS file;
- Managing and monitoring the consumption of inventory; and
- Providing an "as needed" service to site personnel and suppliers.

The risks associated with the transportation, use, handling, storage and disposal of all hazardous chemical substances brought onto site must be assessed and managed by the contractor through a process that incorporates risk reduction using the hierarchy of controls as described in Section 6.

Whenever a task-based risk assessment is carried out, consideration must be given to the use of chemical substances (e.g. greases, solvents, etc.).

The contractor must provide Safe Work Procedures for the transportation, use, handling, storage and disposal of all hazardous chemical substances to be used on site.

The contractor must provide his employees with all of the Personal Protective Equipment that is necessary to prevent exposure / injury while handling / using the hazardous chemical substances that they will be required to work with. Appropriate PPE must be selected with consideration given to the potential hazards, permeability, penetration, resistance to damage and compatibility with the work tasks.

The contractor's employees must be trained in the safe transportation, use, handling, storage and disposal of the hazardous chemical substances that they will be required to work with or may come into contact with. The training must specifically address PPE requirements (including the correct selection, fitment and use thereof).

All personnel must be trained to understand the potential health effects associated with exposure to hazardous chemical substances and therefore the importance of Safe Work Procedures and PPE. All personnel must be trained on emergency response procedures and first aid measures.

Behaviour-based observations and coaching must include the use / handling of hazardous chemical substances.

An appropriate occupational exposure monitoring and medical surveillance programme must be in place for all personnel potentially exposed to hazardous chemical substances which have the potential to cause immediate or long-term harm.

Emergency showers and eyewash stations must be provided where required by law, or where a risk assessment indicates a need. The emergency showers and eyewash stations must be appropriately located, signposted, and regularly tested and maintained. Employees must receive training on the location and use of the showers / eyewash stations.

An emergency response plan for incidents involving hazardous chemical substances must be in place. Regular and appropriately staged emergency drills (possibly involving external spill response and ambulance support services) must be held and lessons learnt must be incorporated into the emergency response plan.

The contractor must provide appropriate storage facilities for all hazardous chemical substances to be used on site. The storage facilities must be secure and protected from damage. They must also be designed for easy access for firefighting purposes. Where applicable, the storage facility must protect chemical containers from physical damage due to temperature extremes, moisture, corrosive mists or vapours, and vehicles.

The inventory of hazardous chemical substances stored on site must be kept to a minimum. The quantity of each chemical stored must be justifiable.

Storage and segregation requirements for all hazardous chemical substances to be used on site must be based on:

- The quantities of the substances stored;
- The physical state of the substances (solid, liquid or gas);
- The degree of incompatibility; and
- The known behaviour of the substances.

Access to areas where hazardous chemical substances are stored and handled must be limited and controlled.

Every chemical substance container must be adequately and clearly labelled to identify its contents, to indicate precautionary requirements for the substance, and to indicate the date of expiry (if applicable). Pipes used to transfer / convey / distribute chemical substances must be clearly identified (e.g. colour coding). Directional flow must be indicated where practical.

Before any item, equipment or empty container containing a chemical residue is disposed of as general waste, it must be properly decontaminated (where applicable). Before being disposed of, empty chemical containers must also be rendered unusable for carrying water (by puncturing, cutting or crushing them).

Hazardous chemical substance waste (i.e. redundant / expired hazardous chemical substances, containers containing residues, contaminated items / materials, etc.) must be disposed of in accordance with the applicable legislation.

Maintenance, inspection and testing schedules and procedures must be in place for critical equipment associated with hazardous chemical substances.

A system must be in place to ensure that the risks are assessed before any changes are made to equipment and / or processes for the transportation, storage, handling, use or disposal of a hazardous chemical substance.

A programme must be in place to continually investigate possibilities / opportunities for replacing hazardous substances with safer alternatives.

16.44 Radiation

The risks associated with ionising (from naturally occurring radioactive minerals (NORM), radon, and man-made sources), ultra violet (UV) and electromagnetic field (EMF) radiation exposure must be assessed by a competent person.

There must be an inventory of all radiation sources that have the potential to cause adverse health effects. For each radiation source, the type of radiation (e.g. radioisotope, radon, x-ray, EMF, laser, etc.), the strength of the radiation, and the location must be recorded.

Where risk assessment indicates the need, a documented radiation management programme must be developed such that:

- All types of radiation sources are adequately characterised and described;
- Exposures are eliminated or reduced to as low as reasonably practicable (ALARP);
- A clearly defined chain of responsibility (with duties) is provided; and
- Education is provided for employees regarding radiation safety, including the radiation management programme elements.

The ionising radiation management programme must meet all applicable regulatory requirements, and as a minimum must include the following elements (as applicable):

- Surveyed radiation areas and quantification of exposure sources / levels;
- Exposure and medical monitoring programmes based on established investigation levels;
- Transport of radioactive materials in compliance with international radiation transport regulations, when no local regulations are in place;
- Waste monitoring and disposal programmes;
- Feedstock and equipment checks for naturally-occurring ionising radiation;
- Clearance and control procedures for all contaminated materials and equipment leaving or arriving at site (including scrap);
- Leak (wipe) tests on sealed radioactive containment equipment;
- Lock-out procedures for vessels and equipment containing radioactive sources and radon decay product measurement prior to entry;
- Emergency procedures;
- Environmental impact risk assessment (air, water, waste, foods, etc.);
- Product / waste life cycle control; and
- Dose assessment for employees and critical exposure groups, according to documented methods and by a competent person.

Areas with ionising radiation with annual doses greater than 5 milli Sieverts (mSv) must be designated as restricted access or controlled areas. These areas must be identified and mapped, signposted or otherwise clearly communicated to employees working in the area.

Each person whose potential exposure exceeds 5 mSv per annum or who is a designated radiation worker must undergo periodic personal radiation monitoring and medical surveillance designed to show continued fitness for radiation work.

All sources of ionising radiation must be managed in use and when they are either disposed of or securely stored in accordance with local regulations. Each operation where individual worker's exposures could exceed 5 mSv per annum must have a trained radiation protection adviser or ready access to a trained protection consultant.

There must be documented procedures for the inspection, assessment and maintenance of the controls, and emergency procedures to deal with incidents involving ionising radiation sources (including fire and explosions). All controls must be reassessed annually to ensure their continued effectiveness and that operating practices are in accordance with written procedures.

16.45 Thermal Stress

Hot areas or activities where employees have experienced or could experience excessive fatigue, muscle cramp, dehydration, dizziness and other symptoms of heat stress must be identified and described.

Where a risk of thermal stress is determined, a competent person must conduct monitoring surveys on site, in consultation with workers.

For defined extreme thermal conditions and job activities, medical examinations must include information about the operator's physiological and biomedical aspects, and an assessment of fitness for the working conditions.

Cold areas or activities where employees have experienced or could experience pain or loss of feeling in extremities, frostbite, severe shivering, excessive fatigue and other symptoms of cold stress must be identified and described.

Workplace thermal stress levels (temperature, air movement, humidity, etc.), activities (work level, etc.) and conditions (clothing, health, etc.) that have the potential to exacerbate thermal stress effects must be adequately characterised and described. Workplace exposure assessment must be repeated according to regulatory requirements or whenever there is a change in production, work organisation, process or equipment which may impact thermal stress levels.

Detailed heat stress assessment of identified tasks or jobs must be tiered to:

- Commence with the use of a simple heat stress index as a screening tool; then, if necessary;
- Use rational heat stress indices in an iterative manner to determine the 'best' control methods for alleviating potential heat stress; and
- Undertake physiological monitoring when exposure times are calculated to be less than 30 minutes, or where high level PPE that limits heat loss must be worn.

Detailed cold stress assessment of identified tasks or jobs must be conducted according to current appropriate guidelines that incorporate a cold stress index, to determine the 'best' control methods for alleviating potential cold stress.

When a risk of thermal stress is identified, the following exposure controls must be implemented:

- An acclimatisation period for new workers and those returning from extended leave or sickness;
- Training in the recognition of signs and symptoms of heat or cold stress, emergency procedures and preventative measures;

- Protective observation (buddy system or supervision); and
- A requirement for self-paced working.

The following exposure controls must be considered by a competent person:

- Work / rest regimes and job rotation based on measurements conducted;
- Suitable rest areas with a provision of cool drinking water and cool conditions for high temperatures, or provision of warm drinks and warm conditions for cold temperatures;
- Selection of appropriate clothing or other PPE for extreme temperature conditions;
- The use of engineering controls; and
- Undertake hot / cold tasks during a cooler / warmer time of the day.

Where thermal stress is assessed to be a risk, the operation must develop a suitable emergency response plan.

16.46 Fitness for Work

The contractor must develop and implement a programme to manage employee fitness for work. All employees working on site for whom the contractor is responsible (i.e. direct employees of the contractor as well as the employees of any appointed sub-contractors) must be subject to this programme.

All safety critical jobs (i.e. roles where fatigue or other causes of reduced fitness for work could lead to serious injury, illness or death to employees, significant equipment / plant damage, or significant environmental impact) must be identified and the risks associated with reduced fitness for work in these roles must be assessed.

A programme to manage these risks must be implemented, and it must include:

- Mechanisms for managing fatigue, stress and lack of fitness;
- An alcohol and other (including prescription, pharmaceutical or illicit) drugs policy that includes testing;
- An Employee Assistance Programme providing confidential access to resources and counsellors; and
- Training and awareness programmes.

Each employee has an obligation to present health and safety self fit for work at the start of the day / shift, and to remain fit for work throughout the work period. Reporting for work under the influence of alcohol or any other intoxicating substance will not be tolerated. Any transgression concerning the alcohol and other drugs policy applicable to the project may result in the offending employee's access to the project premises being temporarily or permanently withdrawn.

Alcohol and drug testing on the project premises will be carried out randomly (as employees report for duty and during the course of the day / shift), following significant incidents (all persons involved), and whenever there is reasonable suspicion. Alcohol and drug testing may also be carried out as part of a Pre-Employment Medical Examination.

Sleep deprivation during shift work or from excessive working hours is a known cause of fatigue. Fatigued employees are at increased risk of accidents. Shift system design must consider:

- The effect on worker fatigue;
- The effects of activities carried out during scheduled and overtime hours;
- The impact on sleep cycles of activities such as commuting to and from site; and

- The monitoring and control of working hours.

The contractor is responsible for the administration of the working hours of his employees as well as the employees of any appointed sub-contractors. The maximum working hours per day and the minimum rest times between shifts must be specified in the contractor's Health and Safety Management Plan and must comply with all applicable legislation.

All employees engaged in safety critical jobs must undergo fitness assessments (medical examinations) which must be carried out prior to the commencement of employment on the project, prior to a change in role, periodically based on an employee's individual risk profile, and on termination of employment on the project:

- Pre-Employment Medical Examination – to assess the physical suitability of the person for the role and environment in which he will work (carried out prior to the commencement of employment on the project and prior to induction);
- Periodic (Surveillance) Medical Examination – to assess the ongoing physical condition of an employee to determine if his role is impacting on his health and whether the employee's fitness level is still adequate for the role he holds (these medical examinations are "risk driven" – the specific protocol followed and the frequency of the examinations will depend on the applicable legal requirements and the employee's individual risk profile as determined by his personal fitness, the nature of his role / duties, and the environment in which he works / occupational health hazards to which he is exposed). The periodic medical assessment programme must include:
 - ♦ The identification of modifiable risk factors that may impact fitness for work;
 - ♦ Education and support to maintain health or address identified risk factors; and
 - ♦ Education and support to help employees regain their fitness for work.
- Role Change Medical Examination – to assess an employee's physical suitability for a different role and work environment (carried out prior to a change in role / duties);
- Exit (Post-Employment) Medical Examination – to determine the total physical impact of the work the employee performed (carried out on termination of employment on the project if the employee worked on the project site for more than six months).

Note: The results of an Exit Medical Examination from previous employment will not be accepted as a Pre-Employment Medical Examination.

Note: The medical examinations described above may only be carried out by an occupational medical practitioner (i.e. a medical doctor who holds a qualification in occupational medicine).

A detailed job (role) description and an exposure profile (noise, dust, heat, fumes, vapours, etc.) must be provided for each employee or group of employees. The medical examinations that an employee undergoes must be based on (i.e. the employee's fitness must be assessed against) the information contained in these documents as well as the baseline risk assessment for the work. This information must be made available to the occupational medical practitioner performing the medical examination.

For each role, the medical criteria for fitness must be documented and these must be based on an evaluation of the physical and medical requirements for the role.

Depending on the circumstances, certain vaccinations may need to be provided to employees.

The medical examinations carried out for all drivers and operators must include testing / assessment for medical conditions that could affect the safe operation of vehicles or equipment.

Specific testing / questioning must be carried out to determine if an individual:

- Suffers from epilepsy or any other medical condition deemed to be a risk by the occupational medical practitioner;
- Makes use of chronic medication that could affect performance;
- Is colour-blind; or
- Has poor day or night vision.

The medical examinations carried out for employees that are required to work at height must include testing / questioning to determine if an individual suffers from epilepsy, hypertension (high blood pressure) or any other medical condition deemed to be a risk (with regard to working at height) by the occupational medical practitioner.

Electricians must be tested for colour-blindness.

With regard to the placement of new employees:

- Prospective employees must be referred to a suitable occupational medical practitioner (doctor) for a "Pre-Employment Medical Examination";
- If an individual is found to be medically "unfit for placement", the doctor will indicate which work activities cannot be performed by the person;
- The individual may still be employed on the project if his medical restrictions can be accommodated and provided that no legislation is transgressed.

A process must be established to manage medical restrictions that may be placed on an employee. For every employee with a medical restriction, regular follow up visits with the occupational medical practitioner must be arranged to ensure that each case is proactively managed.

An employee in a safety critical job must report (to his supervisor) any condition that might impair his ability to safely perform the duties associated with his role. A mechanism must be in place for such reports to be referred to an occupational medical practitioner to determine if the employee is fit to continue with his work.

Proof of all medical examinations (i.e. certificates of fitness signed by an occupational medical practitioner) must be kept on site and these records must be readily available for inspection by the nominated project management representative.

An employee's certificates of fitness must be included in his Personal Profile (dossier). If an Employee Personal Profile (dossier) hasn't already been compiled for a particular employee, then this must be done without delay following the employee's Pre-Employment Medical Examination.

No employee in a safety critical role may commence work on site without proof that he has undergone a Pre-Employment Medical Examination.

Occupational medical examinations and data interpretation may only be carried out by medical practitioners that are appropriately qualified and certified to do so.

Occupational medical data contained in reports to management must be grouped and summarised to ensure that the confidentiality rights of each individual employee are maintained.

All occupational medical data and records must be retained for at least 40 years.

16.47 Legionnaires Disease

All equipment with the potential for generating Legionella (such as cooling towers and associated equipment, air-handling systems, hot water services and showers) must be identified and the risks of contamination and aerosol generation assessed.

Where there is an assessed risk that Legionella could grow in the system and cause harm, a programme must be in place such that:

- All such equipment is identified on a register. The register must contain details of the regular maintenance, cleaning and checking programmes;
- Control measures are in place to minimise aerosol emissions;
- There must be a documented water treatment programme, including procedures for inspection, assessment and maintenance of the controls; and
- New or retrofitted equipment is designed and constructed to minimise the risk of Legionella growth.

•
Where available, the Legionella plate count test should be used if more effective methods are not available.

Good maintenance procedures must be followed to minimise the risk of significant contamination of equipment with other bacteria and microbial organisms.

Adequate procedures must be available for disinfecting systems if significant concentrations of Legionella bacteria are present. Once disinfected, systems must be retested to confirm effectiveness of treatment.

16.48 HIV / AIDS

The contractor must assess the risks posed by HIV. Appropriate mitigation strategies must be implemented as required.

Discrimination towards employees on the basis of actual or perceived HIV status is forbidden.

All information on the HIV status and condition of employees and community members, including that relating to counselling, care and treatment and receipt of benefits, must be maintained in medical confidence.

HIV / AIDS screening may not be a requirement for recruitment or a condition of employment.

17. Occupational Hygiene

These services are to be provided by TCP):

- Chemical agents =Gases, vapours, solids, fibres, liquids, dusts, mists, fumes, etc.
- Physical agents =Noise, Vibration, Heat, Cold, Electromagnetic fields, lighting etc.
- Biological agents =Bacteria, fungi, etc.
- Ergonomic factors =Lifting, stretching, and repetitive motion.
- Psychosocial factors =Stress, workload and work organisation

TCP Occupational health must provide the contractor with the health risk assessment in respect of existing Occupational Health Risk on Sites

Additionally an Occupational Health Program for monitoring the existing Occupational health Risk will be given to the Contractor

The contractor must conduct an Occupational Health Risk Assessment in respect of their trade.

The contractor must appoint an Approved Inspection Authority (AIA) for Occupational Hygiene to conduct the identified Occupational hygiene Surveys.

17.1 Lighting

- Should be measured once-off within 6 months of new installations prior to work commencing for the first time in any area
- The installations should be placed on a maintenance/ repair/ replacement schedule by management. Proof of this should be available
- Lighting and ventilation shall comply with the National Building Regulations (SANS 10400-O: Lighting and Ventilation) before occupancy is established
- Measurements do not need to be conducted by an Approved Inspection Authority for Occupational Hygiene

17.2 Particulate and Gas/ Vapour Exposures (page 127)

The concentration of an HCS in the air is, or maybe, such that the exposure of employees working in that workplace exceeds the recommended limit without the wearing of respiratory protective equipment, is zoned as a respirator zone

17.3 Thermal Stress

Hot areas or activities where employees have experienced or could experience excessive fatigue, muscle cramp, dehydration, dizziness and other symptoms of heat stress must be identified and described.

Where a risk of thermal stress is determined, a competent person must conduct monitoring surveys on site, in consultation with workers.

For defined extreme thermal conditions and job activities, medical examinations must include information about the operator's physiological and biomedical aspects, and an assessment of fitness for the working conditions.

Cold areas or activities where employees have experienced or could experience pain or loss of feeling in extremities, frostbite, severe shivering, excessive fatigue and other symptoms of cold stress must be identified and described.

Workplace thermal stress levels (temperature, air movement, humidity, etc.), activities (work level, etc.) and conditions (clothing, health, etc.) that have the potential to exacerbate thermal stress effects must be adequately characterised and described. Workplace exposure assessment must be repeated according to regulatory requirements or whenever there is a change in production, work organisation, process or equipment which may impact thermal stress levels.

Detailed heat stress assessment of identified tasks or jobs must be tiered to:

- Commence with the use of a simple heat stress index as a screening tool; then, if necessary;
- Use rational heat stress indices in an iterative manner to determine the 'best' control methods for alleviating potential heat stress; and
- Undertake physiological monitoring when exposure times are calculated to be less than 30 minutes, or where high level PPE that limits heat loss must be worn.

Detailed cold stress assessment of identified tasks or jobs must be conducted according to current appropriate guidelines that incorporate a cold stress index, to determine the 'best' control methods for alleviating potential cold stress.

When a risk of thermal stress is identified, the following exposure controls must be implemented:

- An acclimatisation period for new workers and those returning from extended leave or sickness;
- Training in the recognition of signs and symptoms of heat or cold stress, emergency procedures and preventative measures;
- Protective observation (buddy system or supervision); and
- A requirement for self-paced working.

The following exposure controls must be considered by a competent person:

- Work / rest regimes and job rotation based on measurements conducted;
- Suitable rest areas with a provision of cool drinking water and cool conditions for high temperatures, or provision of warm drinks and warm conditions for cold temperatures;
- Selection of appropriate clothing or other PPE for extreme temperature conditions;
- The use of engineering controls; and
- Undertake hot / cold tasks during a cooler / warmer time of the day.

Where thermal stress is assessed to be a risk, the operation must develop a suitable emergency response plan.

17.4 Measuring and Monitoring

The workplace exposure (or potential exposure) of persons to occupational health stressors must be measured and monitored to determine the effectiveness of control measures as well as compliance with legal and other requirements, particularly Occupational Exposure Limits.

All such measuring and monitoring must be carried out by an Approved Inspection Authority (i.e. a specialist service provider that is appropriately registered with a governing authority).

A plan for measuring and monitoring occupational exposure must be developed and it must include:

- Detail of what must be measured and monitored, based on a risk assessment and / or identified legal or other requirements;
- The frequency of measurement and monitoring;
- A description of the necessary equipment;
- Data quality requirements and controls (including details on the sample size for statistical validation and any rejection criteria);
- The sampling and analysis method(s) including any laboratory certification requirements; and
- The competency requirements for persons carrying out workplace monitoring.

Each instrument and item of equipment used for occupational exposure measurement and / or monitoring must be:

- Properly maintained to ensure compliance with legislative requirements;
- Controlled and safeguarded from unintentional adjustments;
- Suitably stored and protected from damage; and
- Calibrated or verified against a traceable standard at specific intervals (calibration records must be retained).

Each analytical laboratory service that is used must have implemented a credible quality assurance or quality control programme.

All monitoring results obtained must be analysed on a regular basis to:

- Identify trends and potential exceedances of legal or other requirements (such as Occupational Exposure Limits);
- Identify inconsistent or unusual results;
- Evaluate the effectiveness of existing control measures;
- Measure performance against stated objectives; and Identify continual improvement opportunities.

Each exceedance of a specified requirement or limit must be recorded, investigated and reported. Appropriate corrective actions must be identified and implemented.

18. Temporary works

A contractor must appoint a temporary works designer in writing to design, inspect and approve the erected temporary works on site before use.

A contractor must ensure that all temporary works operations are carried out under the supervision of a competent person who has been appointed in writing for that purpose.

A contractor must ensure that all temporary works structures are adequately erected, supported, braced; and

A contractor must ensure that, all temporary works structures are adequately erected, supported, braced and maintained by a competent person so that they are capable of supporting all anticipated vertical and lateral loads that may be applied to them, and that no loads are imposed onto the structure that the structure is not designed to withstand;

All temporary works structures are done with close reference to the structural design drawings, and where any uncertainty exists the structural designer should be consulted; detailed activity specific drawings pertaining to the design of temporary works structures are kept on the site and are available on request to an inspector, other contractors, the client, the client's agent or any employee;

All persons required to erect, move or dismantle temporary works structures are provided with adequate training and instruction to perform those operations safely; all equipment used in temporary works structure are carefully examined and checked for suitability by a competent person, before being used;

All temporary works structures are inspected by a competent person
all temporary works structures are inspected by a competent person immediately before, during and after the placement of concrete, after inclement weather or any other imposed load and at least on a daily basis until the temporary works structure has been removed and the results have been recorded in a register and made available on site;

No person may cast concrete, until authorization in writing has been given by the competent person; if, after erection, any temporary works structure is found to be damaged or weakened to such a degree that its integrity is affected, it is safely removed or reinforced immediately;

- adequate precautionary measures are taken in order to—
- secure any deck panels against displacement; and
- prevent any person from slipping on temporary works due to the application of release agents;
- as far as is reasonably practicable, the health of any person is not affected through the use of solvents or oils or any other similar substances;
- upon casting concrete, the temporary works structure is left in place until the concrete has acquired sufficient strength to safely support its own weight and any imposed load, and is not removed until authorization in writing has been given by the competent person contemplated in paragraph (a);
- The foundation conditions are suitable to withstand the loads caused by the temporary works structure and any imposed load in accordance with the temporary works design.
- provision is made for safe access by means of secured ladders or staircases for
- a temporary works drawing or any other relevant document includes construction sequences and methods statements;
- the temporary works designer has been issued with the latest revision of any relevant structural design drawing;
- a temporary works design and drawing is used only for its intended purpose and for a specific portion of a construction site; and
- The temporary works drawings are approved by the temporary works designer before the erection of any temporary works.

No contractor may use a temporary works design and drawing for any work other than its intended purpose.

19. Structure

A contractor must ensure that,

all reasonably practicable steps are taken to prevent the uncontrolled collapse of any new or existing structure or any part thereof, which may become unstable or is in a temporary state of weakness or instability due to the carrying out of construction work;

No structure or part of a structure is loaded in a manner which would render it unsafe; and

all drawings pertaining to the design of the relevant structure are kept on site and are available on request to an inspector, other contractors, the client and the client's agent or employee.

An owner of a structure must ensure that;

Inspections of that structure are carried out periodically by competent persons in order to render the structure safe for continued use;

That the inspections contemplated in paragraph (a) are carried out at least once every six months for the first two years and thereafter yearly;

The structure is maintained in such a manner that it remains safe for continued use;

The records of inspections and maintenance are kept and made available on request to an inspector.

20. Emergency Preparedness and Response

The contractor must develop, implement, test and maintain an Emergency Response Plan (incorporating emergency evacuation procedures) that focuses specifically on the contractor's team and work activities. The plan must be risk-based and must detail the procedures that must be followed when responding to all potential emergency scenarios such as a medical emergency (including first aid response), a fire, an explosion, a hazardous substance spill, flooding, rescue from height, rescue from a confined space, etc.

The contractor's Emergency Response Plan must be aligned with the Emergency Response Plan developed for the project.

Potential off-site emergency scenarios must be included (e.g. emergency scenarios related to the transport of personnel, the transport of hazardous materials, and personnel performing work in remote locations).

Consideration must be given to neighbours, and to the availability and capability of local emergency services. Details of any arrangements with external emergency response service providers must be included.

The Emergency Response Plan must satisfy and comply with all applicable legal requirements.

The plan must be adequately resourced to ensure effective implementation. These resources must include appropriate personnel, external emergency response service providers, emergency response equipment, and warning devices. All equipment and warning devices must be identified, maintained and tested to ensure availability at all times.

Accountability for the Emergency Response Plan must be clearly defined. An Emergency Response Team (ERT) responsible for the implementation, management and execution of the Emergency Response Plan must be established. The roles and responsibilities of each team member must be clearly defined in the plan. Each team member must receive appropriate training to ensure that each role is performed competently.

The process for managing incident communication, notification, and reporting must be incorporated into the Emergency Response Plan. The responsible person(s) must be clearly identified, and the protocols for communicating with internal and external stakeholders must be defined.

Emergency evacuation procedures must be developed and included in the Emergency Response Plan.

A copy of the plan must be provided to the nominated project management representative for approval prior to site establishment.

The Emergency Response Plan must be formally reviewed (and amended if necessary) on at least an annual basis, and following any emergency situation, to ensure that it remains appropriate and effective.

At each project work site:

- A suitable evacuation alarm (siren) must be provided. If work is to be carried out in proximity to an existing operational plant, the alarm provided by the contractor must be distinctly different (in terms of the sound that it generates) to any alarm installed in the operational plant. All persons working in an area where an evacuation alarm is sounded must respond to it immediately.
- Suitable fire-fighting equipment must be provided and maintained, and personnel must be trained in fire-fighting procedures and the use of fire-fighting equipment.

- Suitable first aid equipment and supplies must be provided and maintained, and an adequate number of appropriately trained First Aiders must be in place (refer to Section 14.2).
- Emergency assembly points positioned in safe locations away from buildings, plant and equipment must be designated (and conspicuously signposted). In the event of an evacuation, all persons (i.e. personnel and visitors) must assemble and be accounted for at these emergency assembly points.
- All personnel must receive awareness training on the applicable emergency response procedures, and all visitors entering the site must be properly instructed in these procedures.
- The emergency response procedures must be displayed on each notice board.
- A diagram (site plan) indicating evacuation routes, emergency assembly point locations, and the positioning of emergency equipment (fire extinguishers, first aid boxes, etc.) must be prominently displayed in all buildings and plants, in all offices, on all notice boards, and in other locations on the site as may be required.
- An up-to-date list of emergency telephone numbers must be compiled and maintained. A copy of this list must be posted at each site entrance, in each office, near each telephone, and on every notice board.
- Emergency response drills must be conducted to test the effectiveness of the emergency procedures and equipment, as well as the knowledge and proficiency of the response personnel. Where appropriate, drills must include liaison with and the involvement of external emergency response service providers. A variety of emergency scenarios must be tested including, but not limited to, medical emergencies, fires, rescues, and hazardous substance spills. A drill must be carried out one month after site establishment and six-monthly thereafter.

Each drill must be monitored and the outcomes (highlights and shortcomings) must be documented. Corrective actions must be identified and implemented to address the shortcomings, and the Emergency Response Plan and associated procedures must be amended as required.

20.1 Fire Fighting

The contractor must ensure that Fire Fighting requirements are met

20.2 First Aid

The contractor must ensure that First Aiders are trained and appointed as described in (Section 9.5)

20.2.1 First Aid Kits

A suitable first aid kit (i.e. appropriate to the level of training) must be readily available to each First Aider. All kits must be provided and maintained by the contractor.

Taking into account the type of injuries that are likely to occur in the workplace, each first aid kit must contain suitable equipment and supplies. First aid equipment and supplies required by applicable legislation must be provided as a minimum.

The contents of each first aid kit must be kept clean and dry. Each kit must be contained in either a portable weatherproof case / bag or a steel box mounted to a fixed structure. Access to first aid equipment / supplies must be limited to train First Aiders only. Access to portable kit bags must be controlled and steel first aid boxes mounted in the workplace must be kept locked.

Approved signage must be in place to indicate the locations of the first aid boxes / bags.

A record of each treatment administered must be kept in a suitable register.

The first aid kits must, as a minimum, contain the following equipment and supplies:

Table 20.2.1-1 Minimum Requirements to be included when equipping first aid boxes

Item 1:	Wound cleaner/ antiseptic – 100ml;
Item 2:	Swabs for cleaning wounds;
Item 3:	Cotton wool for padding – 100g;
Item 4:	Sterile gauze – minimum quantity 10;
Item 5:	1 x Pair of forceps – for splinters;
Item 6:	1 x Pair of scissors – minimum size 100mm
Item 7:	1 x Set of safety pins;
Item 8:	4 x Triangular bandages;
Item 9:	4 x Roller bandages – 75mm x 5m;
Item 10:	4 x Roller bandages – 100mm x 5m;
Item 11:	1 x Roll of elastic adhesive – 25mm x 3m;
Item 12:	1 x Non-allergenic adhesive strip – 25mm x 3m;
Item 13:	1 x Packet of adhesive dressing strips – minimum quantity 10 assorted sizes;
Item 14:	4 x First aid dressings – 75mm x 100mm;
Item 15:	4 x First aid dressings – 150mm x 200mm;
Item 16:	2 x Straight splints;
Item 17:	2 x Pairs large and 2 x pairs medium disposable latex gloves;
Item 18:	2 x CPR mouth pieces or similar devices.

Additional items / supplies may need to be provided depending on the nature of the workplace (specific hazards) and the level of training of the first aider in position of the kit.

21. Management Review

A review of the contractor's Health and Safety Management System must be completed annually to ensure that the system continues to be effective in managing health and safety performance and meeting project requirements.

The review must evaluate if there is any need for change and must identify actions to improve the system.

The review must be led by senior management and the following must be considered:

- The suitability of the policy adopted for the project;
- The impact of changing legislation;
- The management of risk;
- Health and safety objectives and performance indicators;
- Changing expectations and requirements of relevant stakeholders;
- Changes to the contractor's scope, schedule, designs, etc.;

- Changes to the contractor's organisational structure;
- Communication and feedback (particularly from employees, Project representatives, and client representatives);
- The effectiveness of the management of change process;
- Workplace exposure monitoring and medical surveillance;
- The status of corrective actions;
- Performance statistics, including an annual summary of safety statistics, and occupational hygiene monitoring and medical surveillance results;
- Non-conformances (findings) from completed audits;
- Follow up on actions from previous management reviews; and
- Recommendations and opportunities for improving the effectiveness of the management system.

A record of each completed management review must be retained and it must include all decisions and identified actions concerning alterations, modifications or improvements to the management system that demonstrate a commitment to continual improvement.

For occupational hygiene: **Approved Inspection Authority (AIA) for Occupational Hygiene**

22. Management of Change

To ensure that proposed changes do not give rise to unacceptable health or safety risk, the contractor must develop and implement a process for identifying and managing change in the workplace (e.g. changes to scope, schedule, procedures, work methods, site conditions, designs, plans, plant and equipment, materials, processes, etc.) that may impact on health or safety performance.

The management of change process must take into consideration that changes may be planned or unplanned, sudden or gradual, temporary or permanent.

The process must aim to ensure that:

- Changes are identified and assessed before they are implemented;
- Careful consideration is given to managing the risks associated with any change;
- Due diligence can be shown to have taken place;
- The number of unsatisfactory or unnecessary changes is minimised;
- The right people are involved in the change process; and
- All statutory requirements are met.

All risks associated with a proposed change must be evaluated and ranked. The risks that are ranked as moderate or higher must be managed to prevent serious injury or illness.

It must not simply be assumed that a change will not result in significant risks. All proposed changes must be formally evaluated. The evaluation or review must include:

- An appropriate level of technical expertise;
- The involvement of the workforce potentially affected by the proposed change; and
- Approval of the change by a person with at least the same level of authority as those who control the existing process or item being changed.

23. Sub-contractor Alignment / Stakeholder management

Processes must be in place to ensure that the health and safety risks associated with the procurement of materials, equipment, services and labour are identified, evaluated and effectively managed.

A process for evaluating a sub-contractor's (or supplier's) ability to provide materials, equipment, services and labour that meet defined specifications must be in place. A prospective sub-contractor's health and safety management expertise, experience and capability (including previous health and safety performance) must be formally assessed prior to any contract or purchase order being awarded.

Each appointed sub-contractor must develop and implement a detailed Health and Safety Management Plan based on the requirements of the contractor's Health and Safety Management Plan and the Health and Safety Specification for the project. This plan must be reviewed and approved by the contractor prior to the commencement of any work.

The properties of all materials provided to the project must be adequately understood, documented and integrated into operating procedures where exposure to these materials presents a significant health or safety risk.

Procedures, commensurate with the evaluated risk, must be in place for the receiving, storing, dispatching and transporting of all equipment and materials.

Before work commences on any contract, all sub-contractor personnel must receive comprehensive orientation and induction training (refer to Section 11).

All work carried out by a sub-contractor must be managed (activity supervised) throughout the contract period and performance must be reviewed (audited) on a regular basis (refer to Section 21).

24. Measuring and Monitoring

The workplace exposure (or potential exposure) of persons to hazardous substances or agents must be measured and monitored to determine the effectiveness of control measures as well as compliance with legal and other requirements, particularly Occupational Exposure Limits.

All such measuring and monitoring must be carried out by an Approved Inspection Authority (i.e. a specialist service provider that is appropriately registered with a governing authority).

A plan for measuring and monitoring occupational exposure must be developed and it must include:

- Detail of what must be measured and monitored, based on a risk assessment and / or identified legal or other requirements;
- The frequency of measurement and monitoring;
- A description of the necessary equipment;
- Data quality requirements and controls (including details on the sample size for statistical validation and any rejection criteria);
- The sampling and analysis method(s) including any laboratory certification requirements; and
- The competency requirements for persons carrying out workplace monitoring.

Each instrument and item of equipment used for occupational exposure measurement and / or monitoring must be:

- Properly maintained to ensure compliance with legislative requirements;
- Controlled and safeguarded from unintentional adjustments;
- Suitably stored and protected from damage; and
- Calibrated or verified against a traceable standard at specific intervals (calibration records must be retained).

Each analytical laboratory service that is used must have implemented a credible quality assurance or quality control programme.

All monitoring results obtained must be analysed on a regular basis to:

- Identify trends and potential exceedances of legal or other requirements (such as Occupational Exposure Limits);
- Identify inconsistent or unusual results;
- Evaluate the effectiveness of existing control measures;
- Measure performance against stated objectives; and
- Identify continual improvement opportunities.

Each exceedance of a specified requirement or limit must be recorded, investigated and reported. Appropriate corrective actions must be identified and implemented.

25. Incident Reporting and Investigation

The contractor must establish a procedure for the management of all health and safety incidents. This procedure must define the responsibilities, methodologies and processes that must be followed for:

- Reporting an incident;
- Investigating an incident;
- Analysing an incident to determine the root cause;
- Identifying and implementing corrective actions to prevent a recurrence; and
- Communicating information concerning an incident to relevant persons and / or groups.

Please Note: Arrangements must be in place to ensure that proper medical care is provided to any contractor (or sub-contractor) employee that suffers an occupational injury or illness (refer to Section 15). These arrangements must be described in the contractor's Health and Safety Management Plan.

An incident may have multiple impacts. For each impact, the Actual Consequence and the Maximum Reasonable Outcome must be evaluated. Each impact must be evaluated independently, with the most significant classification forming the primary rating of the incident.

A Near Hit is an incident. All Near Hits must be reported.

The Maximum Reasonable Outcome (MRO) is based on a risk evaluation of the maximum reasonable consequence of an impact and the likelihood of the event occurring again given a reasonable failure of existing controls. Using the matrix referred to above, each impact must be evaluated and classified as:

- Low;
- Moderate;
- High; or
- Extreme.

An incident must be reported on the same work day or shift on which it occurs and preliminary details must be recorded

Depending on the Actual Consequence and Maximum Reasonable Potential Outcome of the impact(s), the relevant internal and external parties must be notified in accordance with specified protocols and timeframes, and legislative requirements.

In the event of a significant incident (i.e. an incident with an Actual Consequence of Moderate, Major or Catastrophic, or a Maximum Reasonable Potential Outcome of High or Extreme, work must cease and must only resume once the necessary actions (including the re-evaluation of any relevant risk assessments) have been taken to eliminate or reduce the risk of recurrence. Work must only be permitted to recommence once formal authorisation has been granted by the Project Construction Manager. In the case of incidents with an Actual Consequence of Major or Catastrophic, work must not be permitted to recommence until authorisation has been granted by the relevant government authorities (i.e. the South African Police, the Department of Labour or the Department of Mineral Resources).

The Contract Manager must ensure that an investigation is completed for each incident that occurs, and that appropriately senior personnel participate in, and authorise the outcomes of, each investigation. Incident investigations must be facilitated by competent and experienced persons who have been trained in the appropriate methodology.

All significant incidents (i.e. incidents with an Actual Consequence of Moderate, Major or Catastrophic, or a Maximum Reasonable Outcome of High or Extreme must be investigated using the approved Transnet investigation methodology. Such an investigation must be facilitated by a trained project representative within 7 calendar days.

For all other incidents (i.e. incidents with an Actual Consequence of Insignificant or Minor, or a Maximum Reasonable Outcome of Low or Moderate other methodologies approved by the Project Health and Safety Manager must be used.

Each incident (including Near Hits) must be investigated to a level of detail that is appropriate for the Maximum Reasonable Potential Outcome of the incident.

Each incident must be analysed to determine the root cause, and corrective actions must be identified and prioritised for implementation to eliminate or reduce the risk(s) in order to prevent recurrence of the incident.

For each corrective action, a responsible person must be designated and an appropriate timeframe (target date) for completion of the corrective action must be specified. Progress on implementing corrective actions (i.e. closing incidents) must be monitored and reported on. The implementation of corrective actions must be verified during monthly audits by the Project Health and Safety Advisors but also no later than 30 calendar days after the conclusion of the incident investigation.

The contractor must document the results of each investigation and a report must be submitted to the nominated project management representative within five working days of the incident occurring.

As a minimum, each incident report must include:

- The date, time and location of the incident;
- A detailed description of the incident, including photographs;
- The names of any injured persons;
- Injury details (if applicable);
- A summary of the first aid and / or medical treatment provided (if applicable);

- The current status of any injured persons;
- The root causes of the incident; and
- Detailed corrective actions, including responsible persons and target dates for implementation.

Each significant incident must be summarised for its lessons learnt following the investigation. This information must be reviewed by the contractor's Project Manager to assure completeness, accuracy and relevance before it is shared with (communicated to) all project personnel.

26. Non-conformance and Action Management

The contractor must establish a process for identifying and recording corrective actions arising from:

- Incident investigations;
- Hazard identification and risk assessment;
- Measurement and monitoring;
- Improvement plans and suggestions;
- Managing change;
- Audits and inspections; and
- Safety observations and coaching (safety interactions).

The contractor must establish a procedure for managing actions that addresses:

- Identification, categorisation and prioritisation of actions;
- Formal evaluation and approval of actions (management of change process);
- Assignment of responsibilities, resources and schedules for implementation;
- Implementation of actions;
- Tracking and reporting on implementation status; and
- Monitoring and verifying the effectiveness of the actions.

27. Performance Assessment and Auditing

The contractor must establish and maintain programmes for measuring and monitoring HEALTH AND SAFETY performance on a regular basis. Metrics must include leading and lagging indicators, and be based on qualitative and quantitative data.

27.1 Reporting on Performance

Reports summarising the contractor's health and safety performance on the project must be compiled on a weekly and a monthly basis.

The contractor must be prepared to discuss the content of these reports at scheduled health and safety meetings.

The reports must contain the following information:

- Number of contractor and sub-contractor employees on site;
- Total hours worked on site by contractor and sub-contractor employees (by company);
- Number of incidents by category (i.e. Near Hit, FAI, MTI and LTI);
- Lost Time Injury Frequency Rate (LTIFR) (project to date and 12-month rolling);
- Details of all new incidents for the reporting period and the corrective actions taken or to be taken;
- Feedback (progress updates) on all open incidents and outstanding corrective actions;
- Status and feedback on any employee that may have been injured and has not yet returned to work;



- Details of all health and safety training carried out during the reporting period;
- Number of SOC's (Safety Observations and Coaching) carried out during the reporting period;
- SOC trends identified and proposed action for the coming week or month to maintain positive trends and / or address negative trends;
- Details of all audits, inspections and site visits carried out during the reporting period, and the corrective actions taken (or to be taken) to address all non-conformances;
- Feedback (progress updates) on all open non-conformances and outstanding corrective actions;
- Number of Toolbox Talks conducted during the reporting period (monthly);
- Number of Planned Task Observations (PTO's) carried out during the reporting period (monthly);
- Details of all active risk assessments and Safe Work Procedures highlighting those that are due for review in the coming month (monthly);
- A look ahead (to the coming week, month or quarter) to ensure that appropriate health and safety planning and preparation is done for upcoming work;
- Challenges faced with regard to health and safety; and
- Any other health and safety related information specific to the project that may be required.

Leading indicators (e.g. audit findings, observations, etc.) must be analysed, and any negative trends identified with regard to unsafe behaviour or conditions must be appropriately addressed to prevent incidents.

Lagging indicators (e.g. injuries, illnesses, near hits, etc.) must be investigated in detail to determine the root causes. Corrective actions must be identified, implemented and integrated into Safe Work Procedures to prevent recurrences.

27.2 Audits and Inspections

On a monthly basis, the health and safety management system and workplace activities of the contractor will be audited by a Project Health and Safety Advisor to assess compliance with the project health and safety requirements. Any deviation from these requirements (i.e. non-conformance) that places the health or safety of any person in immediate danger will result in the specific activity being stopped until the non-conformance is corrected.

For each non-conformance determined during any audit, the contractor must identify and implement appropriate corrective actions.

For each corrective action, a responsible person must be designated and an appropriate timeframe (target date) for completion of the corrective action must be specified. Progress on implementing corrective actions (i.e. closing non-conformances) must be monitored and reported on. The implementation of corrective actions will be verified during the monthly audits.

Should it be determined that the contractor's level of compliance is unsatisfactory, all work being performed by the contractor on the project site may be stopped (at the contractor's expense) until an investigation into the reasons for the poor performance has been carried out, a corrective action plan has been developed, and corrective actions have been implemented.

In addition to the audit carried out by the Project Health and Safety Advisor, the contractor must carry out an internal audit on a monthly basis to assess compliance with the project health and safety requirements (including the requirements of this specification and the contractor's Health and Safety Management Plan). Furthermore, the contractor must ensure that each appointed sub-contractor is audited and measured to the same standard. Copies of these audit reports must be submitted to the Project Health and Safety Advisor on a monthly basis.

The contractor must carry out internal health and safety inspections as follows:

- General site health and safety inspections on a daily basis; and
- Inspections of plant, tools and equipment prior to establishment or use on site, and at least monthly thereafter.

All audits and inspections must be carried out by competent persons who have been appointed in writing.

A schedule of planned audits and inspections must be compiled and maintained ensuring that:

- All work areas and all activities are covered at regular intervals;
- All applicable legal requirements are complied with; and
- Areas or activities with significant associated hazards or risks receive greater attention.



Contractor Quality Specification Guideline

TABLE OF CONTENTS

1. Purpose	3
2. Definitions / Abbreviations.....	3
3. Applicable Documents	5
3.1 General	5
3.2 Statutory Regulations	5
3.3 Codes and Standards.....	5
4. Quality System	6
4.1 General	6
4.2 <i>Contractor</i> Quality System Requirements	6
4.3 <i>Contractor / Supplier</i> Documentation Submittal Requirements	6
4.4 Project Quality Plan	7
4.5 Procedures	8
4.5.1 Document Control	8
4.5.2 Design Control	8
4.5.3 Procurement	8
4.6 Contractor Audits	8
4.7 Transnet Audit	9
5. Inspection and Testing	9
5.1 General	9
5.2 Quality Control Plans	10
5.3 Inspection Points	10
5.4 Revision to Quality Control Plans	11
5.5 Kick Off Meeting	11
5.6 Schedule of Inspection	11
5.7 Field Inspection Checklists	11
5.8 Inspection Notification	11
5.9 Inspection and Testing	12
5.10 Inspection Release	12
5.11 Special Processes	12
5.12 Welding Procedures	13
5.13 Material Traceability	14
5.14 Material Certification	14
6. Non-Conforming Products	14
6.1 General	14
6.2 Corrective and Preventative Action	15
7. Concession Requests and Technical Queries	15
7.1 Concession Requests	15
7.2 Technical Queries.....	15
8. Inspection, Measuring and Test Equipment	16
8.1 Calibration	16
8.2 Use of Inspection, Measuring and Test Equipment	16
8.3 Verification of Previous Test Results	16



9. Quality Personnel Qualifications..... 17
10. Quality Records..... 17
Appendix 1 – Sample Quality Control Plan..... 19
Appendix 2 – Concession Request..... 20

1. Purpose

This Specification outlines the minimum requirements to ensure that products and services supplied to TRANSNET are manufactured, provided, constructed or installed in accordance with all specified requirements as defined in the Contract, all associated specifications, drawings, codes and standards.

2. Definitions / Abbreviations

Term, Abbreviation	Meaning
Contract:	An agreement with specific terms between two or more parties or entities based on mutual consent which has legal effects and involves transfer of consideration – usually financial or some other type of benefit.
Contractor:	An employer (organisation) or a person who performs ANY work and has entered into a legal binding business agreement contract to supply a product or provide services to Transnet. This applies to the Suppliers, Vendors, and Consultants, Service providers or Contractors. NB: A Contractor is an employer in his/her own right.
Contractor Documentation Schedule (CDS)	A schedule specifying the <i>Employer's</i> requirements for the document types to be submitted by the <i>Contractor</i> at various stages of the <i>Contract</i> and the timing of the submissions.
Data:	All drawings/documents/data/information/DPs and IOMs required to be supplied under the <i>Contract</i> .
Data Pack (DP):	A compilation of manufacturing data, certification, inspection and testing records prepared by the <i>Contractor</i> to verify compliance with the Contractual requirements.
Employer:	Any person who employs or provides work for any person and remunerates that person.

Term, Abbreviation	Meaning
Field Inspection Checklist (FIC):	A document that details the checks, requirements and test parameters for each type of equipment to permit field installation and pre-commissioning of the equipment
Inspection Release Report (IRR):	A document issued to the <i>Contractor</i> by TRANSNET advising release of materials for shipment. This does not relieve the <i>Contractor</i> of its obligations in accordance with the Terms and Conditions of the <i>Contract</i> .
Inspection Waiver Report (IWR):	A document issued to the <i>Contractor</i> by TRANSNET advising that TRANSNET has waived final inspection for the materials listed in this document. The issue of this report does not preclude further inspections by TRANSNET. It is issued without prejudice and does not relieve the <i>Contractor</i> from the guarantees and obligations included in the <i>Contract</i> .
Installation and Operating Manual (IOM):	A document prepared by the <i>Contractor</i> providing relevant information applicable to the installation and maintenance of the specific equipment, including data relating to consumables (e.g. Oils, etc.)
Non Conformance (NC)	Material, product or workmanship which is not in accordance with the requirements of the <i>Contract</i> .
Non-Conformance Report (NCR):	A document initiated by either TRANSNET or the <i>Contractor</i> advising that certain materials/products/workmanship provided by the <i>Contractor</i> do not conform to the required standards and specifications.
Project Quality Plan (PQP):	A document that outlines the <i>Contractor's</i> strategy, methodology, resources allocation, Quality Assurance and Quality Control coordination activities to ensure that Goods and Services supplied meet or exceed the requirements defined in the <i>Contract</i> drawings, codes and standards.

Term, Abbreviation	Meaning
Quality Assurance (QA):	A formal methodology designed to assess the quality of products or services provided.
Quality Control (QC):	A set of activities intended to ensure that quality requirements are actually being met.
Quality Control Plan (QCP):	A document outlining specific manufacturing/construction inspection and testing requirements, including responsibilities, test acceptance criteria, nomination of witness and hold points.
Technical Query Note (TQN):	A document used by the <i>Contractor</i> to formally clarify a Technical Query related to the scope of supply. This should not be used where a Non-Conformance Report has already been initiated.
TRANSNET:	Transnet SOE Limited
<i>Works Information:</i>	Refers to the <i>Works Information</i> as defined in the <i>Contract</i>

3. **Applicable Documents**

3.1 **General**

All work performed shall comply with the requirements of this Specification, the documentation referenced in the *Contract* and the latest revision/edition of the relevant Codes and Standards referenced herein.

3.2 **Statutory Regulations**

Occupational Health & Safety Act, Act No 85, of 1993 and Regulations as amended.

3.3 **Codes and Standards**

Document No.	Title
ISO 9001:2008/2015	International Standard Series Quality Systems

4. Quality System

4.1 General

The Contractor is responsible for all quality activities necessary to ensure the Work meets the requirements specified in the Contract, and shall manage and coordinate all Quality aspects of the Work in accordance with the requirements of this Specification, together with the Contractor's PQP and QCPs once reviewed and accepted by TRANSNET.

4.2 **Contractor Quality System Requirements**

The *Contractor* shall have and maintain a documented Quality Management System. The *Contractor* may be required to demonstrate its use to TRANSNET. The *Contractor's* Quality Management System should be in accordance with the requirements of International Standard ISO 9001.

The *Contractor* submits the following Quality System documentation to TRANSNET at the time of tender:

- Project Quality Plan
- Quality Policy
- Index of Procedures to be used
- Programme of internal and external audits

4.3 **Contractor / Supplier Documentation Submittal Requirements**

The *Contractor* will make formal submission of this Quality Documentation on award of the *Contract* and at the times defined in the *Contractor's* Documentation Schedule, included in the *Works Information* for the *Contract*.

The Contractor's responsibilities to understand Transnet standard requirements for preparation, submission, receipt, review, and collection of Technical and (or) Deliverable Documentation, as detailed in the Contractor Documentation Schedule (CDS).

TRANSNET uses the *Contractor's* Documentation Schedule (CDS), included in the *Works Information* for the *Contract*, to indicate those documents required to be submitted for information/review and/or acceptance.

The *Contractor* develops and maintains a comprehensive register of documents (*Contractor's* Documentation Register – CDR) that will be generated throughout the project.

The CDR includes all quality related documents. The CDR is a 'live' document and Is

submitted to TRANSNET for review following each revision by the *Contractor*. The CDR indicates the dates of issue of the documents taking into account sufficient time to allow for the TRANSNET review/acceptance cycle prior to the document being required for use.

TRANSNET includes a standard template for the CDR in the Starter Pack issued to the *Contractor* at the start of every *contract*.

4.4 **Project Quality Plan**

Where specified, the *Contractor* submits a PQP to TRANSNET within the period stated in the CDS and in any event not later than 28 days after the *Contract* start date or as agreed during kick off meeting. The PQP details how the *Contractor's* Quality System will be applied to the Scope of Work specified in the *Contract*, and shall address the following:

- Satisfying the technical and quality requirements of the *Contractor's* Scope of Work, and relevant elements of the applicable ISO 9001 standard
- Include all quality activities relevant to the Scope of Work, identifying all procedures, reviews, audits, controls and records used to control and verify compliance with the specified Contractual requirements.
- Include a listing of all special processes (e.g. welding and non-destructive testing, cube testing etc.) envisaged for use, including confirmation of personnel certification as required.
- Include all proposed method statements (for site based work activities).
- Include a description of the Contractor's project organisation, with key positions and responsibilities identified and individuals named. The organisation structure shall also indicate the resources committed to the management and coordination of QA / QC activities.
- Include a listing of all Quality Control Plans (QCPs), and associated Field Inspection Checklists (FICs), as applicable.
- Identify in the PQP any Sub-Contractor/Sub-Supplier work. Sub-Contractor/Sub-Supplier plans are approved by the Contractor, and a copy forwarded to TRANSNET for information.
- Include the proposed Authorised Inspection Authority (where applicable - for pressurised equipment and systems).
- Include a schedule of proposed quality records.

The PQP shall be controlled and re-submitted for approval when required to incorporate any change necessary during the *Contract* duration to ensure that the document is

maintained as an effective control, change management and records. The change management will be done to an agreed policy or procedure.

Note: Where the *Contractor* is required to provide a PQP, no work shall commence until the PQP is accepted by TRANSNET.

4.5 Procedures

The *Contractor's* PQP and procedures shall address the system elements and activities appropriate to the Scope of Work, in compliance with the specified Quality Standard.

Where specified, the *Contractor* submits copies of Quality Procedures for review. In addition, the *Contractor* ensures that copies of all Procedures relevant to the Scope of Work are available for reference by TRANSNET at each work location.

These will include, as applicable, the following:

4.5.1 Document Control

The *Contractor's* PQP shall provide a description of how documents provided by TRANSNET to the *Contractor* are to be managed. The description shall address as a minimum:

- Management tools and databases
- Receipt, registration and maintenance
- Internal and external distribution to *Employer*, third parties and Sub-Contractors
- Management of Codes, Standards and Specifications
- Internal review and approval routines and authorities
- How it is ensured that the correct revisions of documents are available at the point of use including retention periods for all documentation

4.5.2 Design Control

Where the *Contractor* is responsible for any aspect of design related to the Scope of Work, the Quality Plan shall describe the *Contractor's* methods and procedures for the control of these design activities.

4.5.3 Procurement

Where the *Contractor* is responsible for any aspect of procurement related to the Scope of Work, the Quality Plan shall describe the *Contractor's* methods and procedures for the control of these activities.

4.6 Contractor Audits

The *Contractor* shall:

- Carry out audits in accordance with its Quality System at its own and Sub-Contractor's facilities to ensure project quality requirements are being achieved.
- Include a QA Audit Schedule in the *Contractor* PQP submitted to TRANSNET prior to commencement of the Scope of Work. The Audit Schedule shall include all audits to be implemented by the *Contractor* and Sub-Contractor during the execution of the *Contract*.
- Where stipulated in the *Contract*, perform an audit within three months after the *Contract* start date and thereafter at a minimum frequency of three months. Audit reports are submitted to TRANSNET at the completion of each Audit. Where unsatisfactory performance is evident, TRANSNET will direct the *Contractor* to perform additional audits.

4.7 **Transnet Audit**

TRANSNET reserves the right to perform quality audits or participate as an observer in *Contractor* audits to verify compliance with the Contractual requirements. The *Contractor* shall within a time frame as agreed upon, correct any adverse audit finding advised by TRANSNET.

5. **Inspection and Testing**

5.1 **General**

TRANSNET may, at its discretion, perform surveillance inspection at the *Contractor's* premises, the premises of any Sub-Contractor or at the location of the Scope of Work.

Dependent on the nature of the Scope of Work and the frequency of inspections, TRANSNET may elect to have inspection personnel resident at the place of manufacture, fabrication, or assembly.

The *Contractor* ensures free entry and access is given to TRANSNET, certifying authorities and statutory authorities to inspect the Scope of Work and review procedures and quality records at all parts of the *Contractor's* and Sub-Contractor's premises, or at the location of the Scope of Work while any work or test is in progress.

The *Contractor* provides TRANSNET with all necessary tools, calibrated measuring equipment, safety equipment and workspace to verify or witness tests in progress.

While TRANSNET is at the *Contractor's* premises, the *Contractor* provides, free of charge, reasonable facilities including office facilities and reasonable access to a telephone, facsimile machine and computer connection point.

The *Contractor* provides written notice within a time frame as agreed upon, to allow the attendance of TRANSNET and other representatives at nominated witness and hold points.

5.2 **Quality Control Plans**

The *Contractor* prepares and submits QCPs to TRANSNET for review in accordance with the requirements of the *Contract* and PQP.

QCPs must clearly identify all inspection, test and verification requirements to meet the Contractual obligations, specifications, drawings and related details including destructive and non-destructive testing, witness and hold points.

The *Contractor* shall not commence fabrication or manufacture prior to review and approval of the applicable QCP by TRANSNET.

QCPs shall include reference to all tests specified in the *Works Information*.

A typical format for a QCP is shown in Appendix 1. The *Contractor* may use its own format providing all information shown in the sample in Appendix 1 is included.

5.3 **Inspection Points**

The QCP identifies points in the fabrication, manufacturing and/or installation process that are selected for inspection. These points are denoted by the following inspection codes:

- Hold Point (H) Inspection points in the manufacturing cycle, beyond which work shall not proceed without the specified activity, work or function being witnessed. Hold points require written notification to TRANSNET.

- Witness Point (W) An inspection point in the manufacturing cycle that will be witnessed or verified. If TRANSNET confirms it is unable to attend after being provided with the written notification then manufacture may proceed. Witness points require written notification to TRANSNET.

- Review Point (R) A point at which products and quality records are verified and endorsed. Review points are not points that require notification to TRANSNET.

- Surveillance (S) An inspection point in the manufacturing cycle during which any activity, work or function is observed. No formal notification is required.

The *Contractor* maintains the status of testing and inspection by progressively having the QCPs signed off.

5.4 **Revision to Quality Control Plans**

Revision of the QCP is subject to the same submission, review and acceptance routines as described for the original QCP issue.

5.5 **Kick Off Meeting**

After the *Contract* start date, and prior to manufacture, TRANSNET will require a Kick-Off Meeting with the *Contractor* to discuss fully the implications of meeting TRANSNET's quality requirements. This meeting may be held as part of the *Contract* kick-off meeting for each package or may be a separate meeting, subject to the critical or complex nature of the work. This requirement for a pre-inspection meeting may be repeated when Sub-Contractors of key equipment are engaged.

5.6 **Schedule of Inspection**

The *Contractor* shall submit a Schedule showing the proposed dates for inspections and tests nominated in the QCP where witness and hold points are required. The Schedule shall be regularly updated with progress and issued to TRANSNET to show the current inspection and test status.

5.7 **Field Inspection Checklists**

For site installation and construction activities, the *Contractor* prepares Field Inspection Checklists (FICs) to permit inspection and testing of installed equipment and constructed facilities in accordance with the respective QCPs.

FICs are submitted to TRANSNET for initial review. FICs are used to record the results of inspection and testing (where applicable). On completion, FICs are submitted to TRANSNET to confirm satisfactory completion of the tests and inspections at nominated QCP witness and hold points.

5.8 **Inspection Notification**

The *Contractor* notifies TRANSNET in writing at least two calendar weeks prior to the advent of inspections or tests that require witnessing.

For inspections or tests within the country, arrangements are confirmed at least two working days before the event. For inspection and tests outside of the country, arrangements are confirmed at least seven working days before the event.

Inspection notifications include the following essential information:

- Contract Number
- Location of Inspection or Test
- Nature of Inspection or Test
- Date and Time of Inspection or Test
- Name and telephone number of the *Contractor's* Representative.

5.9 **Inspection and Testing**

The *Contractor* is responsible for the conduct of all *Contractor* inspections and tests. This responsibility includes:

- Documenting inspection and test results in the QCPs and relevant FICs.
- Progressively inspecting the quality of the Scope of Work performed, including that of all Sub-Contractors.
- Inspecting to meet all Contractual requirements, in number, type and form
- Inspecting day to day activities, material receipts, issue of material for installation, in-process inspections, and final inspections.

Completed original QCPs and FICs are included in the DP that the *Contractor* submits to TRANSNET.

5.10 **Inspection Release**

At completion of the Scope of Work, either in total or in phases, TRANSNET may issue an Inspection Release Report (IRR) or an Inspection Waiver Report (IWR).

The issue of either an inspection release or waiver of inspection does not relieve the *Contractor* of its obligations under the *Contract*. The *Contractor* ensures that a copy of the release note and final expediting release note for transport, where appropriate, is attached to the delivery docket and accompanies the Work to the designated destination indicated in the *Contract*. Items delivered to TRANSNET without a copy of these documents may not be accepted.

A copy of the inspection release or waiver of inspection is included in the DP.

5.11 **Special Processes**

It is the *Contractor's* responsibility to ensure that all processes which require prequalified procedures and/or work methods are tested and qualified before work begins. This typically covers such activities as welding, non-destructive testing, special fabrication techniques and painting. Unless specified such procedures are the *Contractor's* responsibility and do not

require submission to TRANSNET before work begins. When such procedures are requested, no work shall commence until procedures are approved by TRANSNET.

It is the *Contractor's* responsibility to ensure all operators are qualified for the processes in accordance with the procedure and/or applicable standards. Records of qualification of operators shall be maintained by the *Contractor* and made available to TRANSNET when requested.

Records of qualification of procedures and processes shall be maintained by the *Contractor* in accordance with the applicable procedure or code.

5.12 **Welding Procedures**

Where the *Contractor's* Scope of Work includes fabricated weldments, Welding Procedure Specifications (WPS) defining the method, preparation and sequences to be adopted to achieve a satisfactory welded joint shall be provided for all weld types required in the execution of the *Contractor's* Scope of Work. The procedure shall only be submitted to TRANSNET when requested in the *Contract*.

WPS include all welding essential and non-essential variables for each process used, including appropriate test results. WPS comply fully with the standard or code pertaining to welding required in the execution of the *Contractor's* Scope of Work.

When requested in the *Contract*, a suitably marked "weld map" is completed by the *Contractor* for all items to be fabricated. A summary of WPS is prepared and, when used, is identified on the weld map.

Where TRANSNET approval is required, fabrication is not to commence until written approval of WPS and Welding Procedure Qualification Records (WPQR) is received by the *Contractor*. No welding fabrication will be accepted that is not covered by a TRANSNET approved WPS/WPQR.

Welding Procedure Qualification (WPQ) tests may be witnessed by TRANSNET and/or an independent inspection authority. Testing of the specimens prepared during the WPQ Tests is carried out by an approved testing laboratory, independent of both TRANSNET and the *Contractor*. In certain instances, a certificate to EN 10204 3.1 B or an equivalent as specified by engineer may be required which will be clarified at Tender review and clarification stage.

Where actual weld deposit analysis and weld metal physical properties are required for procedure qualification, the information is taken from the procedure qualification tests. Data listed in the catalogues of the manufacturer of welding consumables is not acceptable.

Welders/welding operators are qualified in accordance with the relevant welding code prior to commencing production fabrication. Specific Welder Qualification (WQ) records will be reviewed by TRANSNET in the *Contractor's* works and should NOT be submitted for review.

A register of welders qualified to work shall be maintained by the *Contractor*.

5.13 **Material Traceability**

Where, and to the extent that material traceability is required, the *Contractor* shall provide its procedures for the maintenance of material identification throughout all phases of manufacture. Methods of identification, routines for re-stamping or stencilling as appropriate shall be defined and agreed with the *Employer*.

Adequate records shall be maintained throughout construction enabling traceability of key materials from final product back to original material certificates. The material traceability records shall form part of the DP

The *Contractor* shall prepare a schedule of materials and equipment that are subject to traceability requirements.

5.14 **Material Certification**

Where specified in the Contract the following certificates shall be provided to TRANSNET and included in the DP.

Type A: A *Contractor's* certificate of compliance with the *Contract*. This certifies that the goods or services are supplied in compliance with the *Contract* without mention of any test results (EN10204 certificate 2.1).

Type B: A certificate issued by a laboratory or test facility independent of the *Contractor's* works. It shall quote test results carried out on the product supplied and state whether compliance with the relevant technical standard, code, etc., has been complied with. (EN10204 certificate 3.1B).

Type C: The same as Type B, the tests are to be witnessed by a third party (EN10204 certificate 3.1C).

6. **Non-Conforming Products**

6.1 **General**

The *Contractor* shall establish and maintain procedures to control material or products that do not meet the specified requirements.

All *Contractor* product and/or materials identified as not conforming to requirements shall be dealt with promptly as follows:

- If the *Contractor* discovers material or product which is not in accordance with the requirements of the *Contract*, i.e. a non-conformance, the *Contractor* shall immediately initiate the non-conformance procedure in terms of the *Contractor's* Quality Management System, advise TRANSNET promptly, and provide a copy of the non-conformance report (NCR) to TRANSNET
- If TRANSNET or its agent identifies a non-conformance, a TRANSNET NCR may be raised.

Originals of all closed out NCRs shall be included in the DP.

6.2 **Corrective and Preventative Action**

If the *Contractor* proposes a disposition of any non-conforming materials or product which varies from the requirements of the Specification or *Contract*, such a proposal shall be submitted in writing to TRANSNET whose decision on the proposal shall be obtained in writing before the non-conforming material or product is covered up or incorporated into the Works, or is the subject of any other disposition.

The disposition of non-conformances which do not vary the requirements of the *Contract*, specification or drawings may be approved by the *Contractor* following discussion and agreement with TRANSNET.

7. **Concession Requests and Technical Queries**

7.1 **Concession Requests**

Where a *Contractor* requests a Concession to deviate from the requirements of the *Contract* or specified requirements, the *Contractor* raises the request with TRANSNET using the format as shown in Appendix 2.

The Concession Requests shall clearly identify all elements of the proposed deviation together with any resulting technical, commercial and/or schedule impacts.

Completed original Concession Requests shall be included in the DP.

7.2 **Technical Queries**

For clarification of technical issues (only), the *Contractor* may submit a Field Engineering Query (FEQ) to TRANSNET in accordance with the *Contract*.

The FEQ shall clearly identify all elements of the query, and all supporting documentation and/or drawings shall be attached where appropriate.

Completed original FEQ's shall be included in the DP.

8. **Inspection, Measuring and Test Equipment**

8.1 **Calibration**

The *Contractor*, including its Sub-Contractors/Sub-Suppliers, shall ensure the calibration of test and measuring equipment is performed and maintained in accordance with the relevant *Contractor* procedures and/or the equipment manufacturer's specifications.

Where calibration is required by an external laboratory, the *Contractor* shall ensure that the facility selected for calibration possesses current certification. Calibration certificates shall contain a statement that the test equipment is accurate to within specified tolerances.

The *Contractor* should establish the frequency of calibration for each item of equipment (including jigs, fixtures or templates) and record the details in a 'Measuring and Test Equipment Register' (or similar).

8.2 **Use of Inspection, Measuring and Test Equipment**

The *Contractor* shall ensure that authorised equipment users:

- Use the equipment in accordance with manufacturer's instructions, and accepted industry practices
- Ensure the equipment is covered by a current calibration certificate
- Conduct the measurements or tests in accordance with the equipment manufacturer's specifications or other relevant specification
- Prior to commencement of each inspection or test activities:
 - Identify the measurements to be made
 - Determine the accuracy required
 - Select the appropriate inspection, measuring or test equipment for the scope of work.

8.3 **Verification of Previous Test Results**

Where the calibration status of the equipment is unknown, expired or has doubtful accuracy, the equipment shall immediately be quarantined, and tagged according to *Contractor's* Quality System procedures. The *Contractor* shall then arrange for either in-house or external calibration, and:

- review all previous test results associated with the suspect equipment;
- identify the inspections, measurements or tests required to re-validate the results;
- ensure that suitable re-testing is performed with calibrated equipment;
- record the results of the re-testing on the respective inspection and test documentation.

9. **Quality Personnel Qualifications**

It is preferable that *Contractor's* personnel engaged in Quality Assurance and Quality Control are members of one or more of the following organisations:

South African Quality Institute

Southern African Society for Quality

It is mandatory that personnel undertaking testing of rail-associated infrastructure are qualified as follows:

10. **Quality Records**

Contractors shall maintain Quality Records necessary to provide objective evidence that demonstrates and verifies achievement of the QA / QC requirements associated with the Scope of Work. All Quality Records, including original source material test certificates and non-destructive test reports, shall be retained by the *Contractor* during the project, and be provided to TRANSNET at the times, and in the quantities specified in the *Contract*.

The *Contractor* shall collate all quality records in the DP and submit the DP to TRANSNET in accordance with the *Contract* and all referenced standards and specifications. This DP shall be compiled progressively, and shall be available for review at all phases of manufacture or construction activities.

The Scope of Work shall not be complete until the *Contractor's* DP, including the quality records from Sub-Contractors/Sub-Suppliers, has been reviewed and accepted by TRANSNET.

The *Contractor* compiles the DP progressively during the execution of the Scope of Work and makes the DP available for review by TRANSNET as required.



The *Contractor* shall retain a copy of all Quality documentation generated during the *contract*, including a copy of the complete DP, for his own records for a minimum period of five years after the completion of the work.

Appendix 1 – Sample Quality Control Plan

Quality Control Plan No. _____	Revision: _____	Date Issued: _____
Contract No. _____	Description: _____	Item No. _____
Contractor _____	Location: _____	

Activity No.	Activity Description	Procedure Reference / Code Specification	Specification Acceptance Criteria	Verifying Document / Report / Certificate	Verification/Witness					
					Contractor		AIA		TRANSNET	
					Action	Sign	Action	Sign	Action	Sign

Rev	Date	Reason for Revision	Drawn	Checked

ACTION

H – Hold. Mandatory Hold Point R – Review (Verify) only

W - Witness S - Surveillance



NOTE: H & W points require formal notification to TRANSNET



Appendix 2 – Concession Request



Request for Concession No:							
Project Name:		Project Number:					
A. SUPPLIER/CONTRACTOR SUPPLIED INFORMATION							
SUPPLIER/CONTRACTOR NAME:			P/O /CONTRACT NO.:				
SUPPLIER/CONTRACTOR CONCESSION NO:			DATE:				
Required concession applicable to: (Item/Material/Equipment/Area)							
Quantity Affected:							
Original Requirements:							
Description of Concession – Revised Requirements:							
Justification:							
Cause :							
Consequence :							
References:							
Original Requirements reference:							
Drawing No.:		Rev.:		Specification No.:		Rev.:	
Drawing No.:		Rev.:		Specification No.:		Rev.:	
Drawing No.:		Rev.:		Specification No.:		Rev.:	
Attached applicable documentation:							



♦ A. SUPPLIER/CONTRACTOR SUPPLIED INFORMATION continued						
(NOTE: This concession will be rejected if the following information is not provided):						
(i) VALUE OF BENEFIT TO CLIENT	(ii) AGREE TO AN EXTENSION OF THE WARRANTY	YES	NO	(iii) ANY IMPACT ON SCHEDULE?	NO	YES
		<input type="checkbox"/>	<input type="checkbox"/>		<input type="checkbox"/>	<input type="checkbox"/>
	IF "YES" WHAT PERIOD?			IF "YES" WHAT PERIOD?		



\$/R.....					
Requested by: (Supplier/Contractor)					
Name:		Title:		Signature:	Date:
B. SITE ADMINISTERED CONTRACT?			<input type="checkbox"/> Yes	<input type="checkbox"/> No	
Possible QC implications:					
Recommended	<input type="checkbox"/>	Rejected	<input type="checkbox"/>		
♦ Recommendations with the following Conditions:					
Area Manager:		Signature:		Date:	
Site Engineer:		Signature:		Date:	
C. RECOMMENDATION BY CONTRACT ADMINISTRATOR:					
Name:		Signature:		Date:	
D. RECOMMENDATION BY ENGINEERING:					
Recommended	<input type="checkbox"/>	Rejected	<input type="checkbox"/>	Conditional	<input type="checkbox"/>
Recommendations:					
PR Engineer:		Signature		Date	
Lead Discipline Engineer:		Signature		Date	
Engineering Manager:		Signature		Date	
Comments:					
E. AREA MANAGER:		Accepted	<input type="checkbox"/>	Rejected	<input type="checkbox"/>
Name:		Signature		Date	
F. Transnet Capital Projects :		Accepted	<input type="checkbox"/>	Rejected	<input type="checkbox"/>
Name:		Signature		Date	

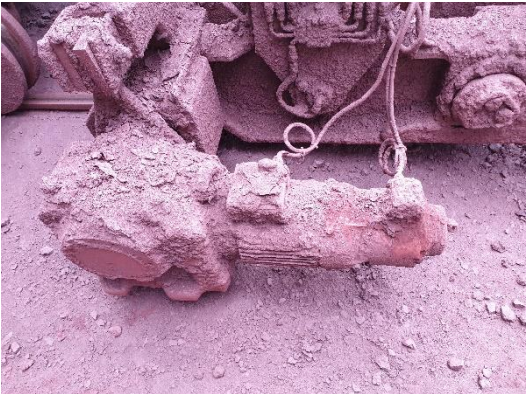

No	Engineering Discipline: Electrical Point Description	Picture reference	Category Refurbishment vs Maintenance	Recommendation
1		Slew & Travel MCCs	Maintenance	<p>Most D.O.L. Cubicles have damaged Door lockable Handles.</p> <p>Potentially a hazardous situation as padlocking becomes almost impossible to achieve. Maintenance to repair</p>
2		Slew; Bucket wheel & Travel MCCs	Maintenance	<p>Most D.O.L. Cubicles have damaged Door lockable Handles.</p> <p>Potentially a hazardous situation as padlocking becomes almost impossible to achieve. Maintenance to repair</p>
3		Slew; Bucket wheel & Travel MCCs	Maintenance	<p>Some D.O.L. Cubicles doors do not close properly.</p> <p>Potentially a hazardous situation as padlocking becomes almost impossible to achieve. Maintenance to repair</p>



<p>4</p>		<p>Slew; Bucket wheel & Travel MCCs</p>	<p>Refurbishment</p>	<p>All the VFFDs are obsolete, OEM end of life reached. To be included as scope in the refurbishment of SR3.</p> <p>Most Travel VFFDs Air filtering elements are clogged with dust. The dust then gets sucked in by the VFFDs cooling fans accelerating the life span of the air filtering elements. The future MCC should be pressurized, to eliminate this problem of large dust ingress into the MCC room.</p>
<p>5</p>		<p>Slew; Bucket wheel & Travel MCCs</p>	<p>Refurbishment</p>	<p>General cooling and pressurization of the MCC (Electrical control rooms) - Advisable to review the present cooling and environmental dust ingress into these Rooms, the present system has not been remarkably effective. Cooling system to be sized according to VFFD requirements. Roof to be sealed & extended by 1m to protect local control station</p> <p>Recommendation:</p> <p>E-House: 2 x 60,000 BTUS (3PH/400v)</p>
<p>6</p>		<p>Slew; Bucket wheel & Travel MCCs</p>	<p>Refurbishment</p>	<p>Slew deck: 2 x 36,000 BTU (1PH/220v)</p>

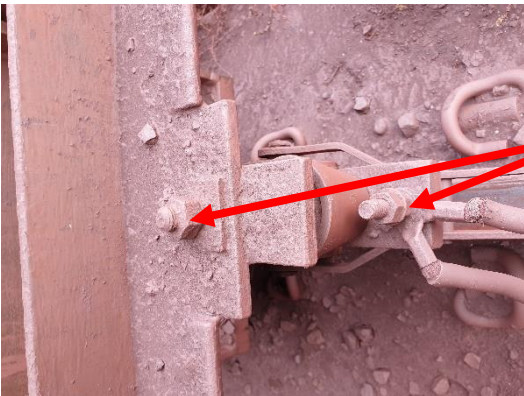

<p>7</p>		<p>Slew motors</p>	<p>Refurbishment</p>	<p>Motors are exposed to product falling on the motor body and obstructs the proper circulation of cooling air. We suggest looking into adding roofs over the Motors as it is the case of the gearboxes</p>
<p>8</p>		<p>Conveyor motors</p>	<p>Refurbishment</p>	<p>Motors are exposed to product falling on the motor body and obstructs the proper circulation of cooling air. We suggest looking into adding roofs over the Motors as it is the case of the gearboxes. Conveyor Drive trains are past their useful life and to be replaced along with pulleys</p>
<p>9</p>		<p>Travel motors</p>	<p>Refurbishment</p>	<p>Motors without roof covers are easily exposed to product falling on the motor body and obstruct the proper circulation of cooling air. We suggest looking into adding roofs over these Motors and redesign them to be stronger, as many are bent or removed because the Holding brackets don't have enough support.</p>

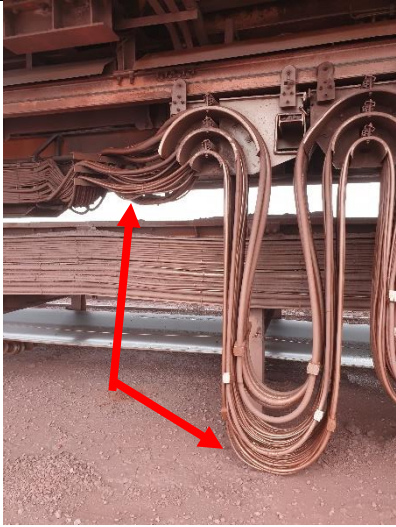

<p>10</p>		<p>LCS, (Local Control Stations)</p>	<p>Maintenance</p>	<p>Some are in a bad start of maintenance; the wiring is in the state shown in the picture here.</p>
<p>11</p>		<p>Operator's Cabin Consoles</p>	<p>Refurbishment</p>	<p>The status is quite bad, wiring is loose and in cases shows signs of being trapped by the Top door.</p> <p>One of these consoles Top door hinges are broken and the joystick may be moved and displaced potentially causing accidental motion movement. Replacing them with new is required</p> <p>The Operator's ergonomic space is presently quite small and in association with that, both the side control consoles were made originally exceedingly small, making it difficult for maintenance repairs and regular maintenance work, hence the state they are presently.</p> <p>Replace with larger stainless steel cabin with space to allow for main chair and ordinary training chair (chairs included). Inclusive of any additional supporting structure required. Levelling system to be refurbished</p> <p>Include for spare operators chair</p>
<p>12</p>		<p>HT switchgear</p>	<p>Refurbishment</p>	<p>HT switchgear appears to be in good condition. Worn power relays to be replaced. Spares to be maintained</p>

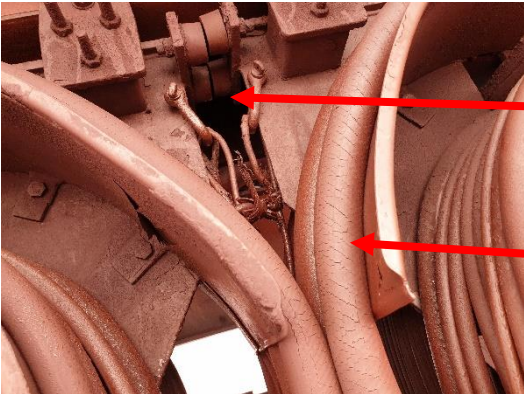

<p>13</p>		<p>Travel Motors</p>	<p>Refurbishment</p>	<p>Some Travel motors Brakes have been removed. All brakes to be replaced as past their useful life</p>
<p>14</p>		<p>Travel Motors</p>	<p>Refurbishment</p>	
<p>15</p>		<p>Travel Motors</p>	<p>Refurbishment</p>	<p>Some Travel motors Roof covers have been removed. Covers to be fabricated and replaced</p>

<p>16</p>		<p>Earth shoes</p>	<p>Maintenance</p>	<p>Several of these Earth shoes are worn and in a bad state of functionality. Maintenance activity</p>
<p>17</p>		<p>Earth shoes</p>	<p>Maintenance</p>	<p>This particular one isn't bonded to the structure. Maintenance activity</p>
<p>18</p>		<p>Earth shoes</p>	<p>Maintenance</p>	<p>Several of these Earth shoes are worn and in a bad state of functionality. Maintenance activity</p>

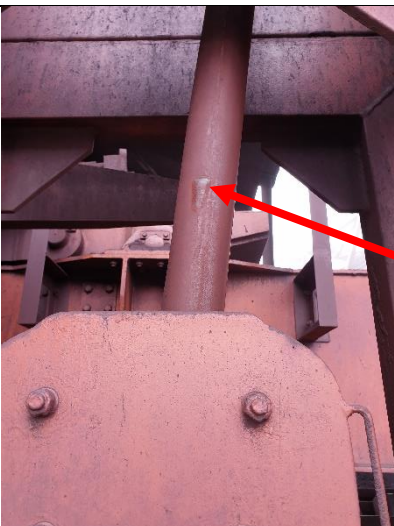

<p>19</p>		<p>Catenary cable system/ T-Bar Festoon</p>	<p>Refurbishment</p>	<p>The leading Loop has too much slack and is running on the ground, causing wear on the cable's insulation.</p> <p>This is due to the lack of slack between the FIXED Cable carrier and the start of the Cable trays</p> <p>The Festoon shows signs of great wear and tear and requires replacing.</p>
<p>20</p>		<p>Catenary cable system/ T-Bar Festoon</p>	<p>Refurbishment</p>	<p>System includes all festoon curved tracks, support brackets, cable trolleys, festoon cables, tow chains, and junction boxes.</p>
<p>21</p>		<p>Catenary cable system/ T-Bar Festoon</p>	<p>Refurbishment</p>	<p>The tension relief rope between the leading cable carrier and the second cable carrier is missing, putting unnecessary strain on the electrical cables.</p> <p>NOTE:</p> <p>Some cables show signs of brittle insulation. The festoon system has passed its useful life and requires replacing</p>



<p>22</p>		<p>Catenary cable system/ T-Bar Festoon</p> <p>Cable carrier wheels.</p>	<p>Refurbishment</p>	<p>These wheels need to be inspected and adjusted or assess the reason why they are climbing or nearly falling off the I Beam.</p>
<p>23</p>		<p>Catenary cable system/ T-Bar Festoon</p> <p>Cable carrier wheels.</p>	<p>Refurbishment</p>	<p>The Festoon shows signs of great wear and tear and requires replacing</p>
<p>24</p>		<p>HT Cable reel</p>	<p>Refurbishment</p>	<p>Cable with some signs of insulation wear. The system has passed its useful life and requires replacing</p>

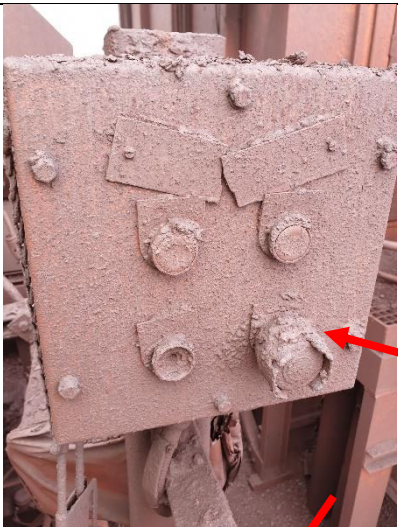
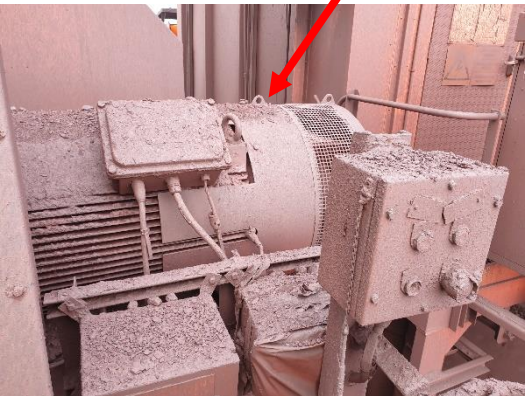

25		HT Cable reel	Refurbishment	<p>Holding bracing brackets with missing bolts . The system has passed its useful life and requires replacing</p>
26		HT Cable reel	Refurbishment	
27		HT Cable reel	Refurbishment	<p>Cable with some signs of insulation wear.</p> <p>Particularly concerning are the wear spots seen on the sides as it passes through the Diverting funnel.</p> <p>The system has passed its useful life and requires replacing. A new system will be required to extend the life span of the machine due to the signs of wear of the structure and cable.</p>





<p>28</p>		<p>Wild vegetation on travel path</p>	<p>Maintenance</p>	<p>Wild vegetation grows along the Travel motor paths and accumulates around the motor/gearboxes. Maintenance activity</p>
<p>29</p>		<p>Trip wire</p>	<p>Maintenance</p>	<p>There is large slack along the Boom conveyor structure Trip wire.</p>
<p>30</p>		<p>Trip wire</p>	<p>Maintenance</p>	<p>This makes the Tripping action ineffective and potentially hazardous to people in the event of a trip action required. Maintenance activity</p>

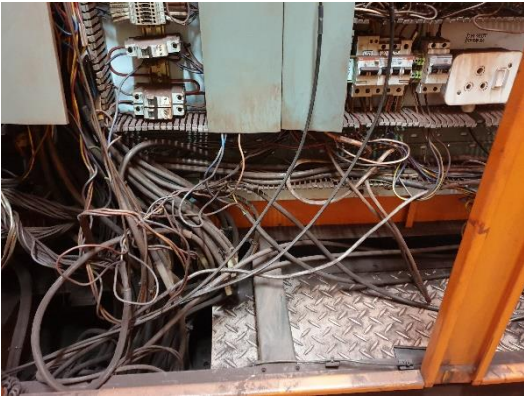



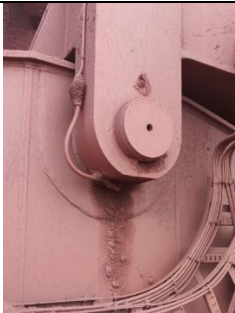

<p>31</p>		<p>Pull Key switches</p>	<p>Maintenance</p>	<p>Broadly speaking they are just dirty, but two were difficult to activate, some level of urgent maintenance is required.</p>
<p>32</p>		<p>Local Maintenance station (Boom tail conveyor)</p>	<p>Refurbishment</p>	<p>This box is full of dry (Hard) dust accumulated around it; the Emergency stop is completely out of action.</p> <p>This is potentially a safety concern. Maintenance stations to be replaced</p>
<p>33</p>		<p>Local Maintenance station (Boom tail conveyor)</p>	<p>Refurbishment</p>	

<p>34</p>		<p>Slew VFFDs.</p>	<p>Refurbishment</p>	
<p>35</p>		<p>Slew VFFDs.</p>	<p>Refurbishment</p>	<p>Obsolete and discontinued Drives in an advanced state of wear and tear. To be replaced along with obsolete Travel and BWheel VFFD's</p> <p>Spares to be maintained</p>
<p>36</p>		<p>Slew VFFDs.</p>	<p>Refurbishment</p>	





<p>37</p>		<p>Main PLC Cubicle and adjacent Relay/Marshalling panel.</p>	<p>Refurbishment</p>	<p>The state of the wiring is quite severely untidy and probably difficult to repair.</p> <p>CPU is still produced by the OEM, but the Range is aged and there is a strong possibility that it won't be around for much longer.</p> <p>This is a concern when extending the life of the machine. To be replaced.</p> <p>The present Simocodes are also obsolete are require replacing with latest Pro V units</p>
<p>38</p>		<p>Main PLC</p>	<p>Refurbishment</p>	<p>1 x Main PLC Enclosure includes:</p> <ul style="list-style-type: none"> • 1 x Siemens PLC system with all the necessary power supplies, processor, I/O, communications modules, and customer terminal blocks, required to replace the existing PLC that is currently installed • 1x door mounted HMI computer/display • 1x Lot of misc. relays, terminals, wiring, nameplates, and all components • Needed to supply power to the enclosure contents • Door switch operated LED light fixture and duplex outlet.
<p>39</p>		<p>PLC Cubicle cabling and wiring</p>	<p>Refurbishment</p>	







<p>40</p>		<p>PLC Cubicle cabling and wiring</p>	<p>Refurbishment</p>	
<p>41</p>		<p>Slew Carrier</p>	<p>Refurbishment</p>	<p>From inspection the signs are visible of major wear and tear of the components that make up the Drag Chain</p> <p>Typically Drag chains have a life span of 12 to 15 years, this particular one has surpassed its typical life span already.</p> <p>Install grating and replace drag chain with festoon & canopy</p>





No	Engineering Discipline: Mechanical Point Description	Picture reference	Category Refurbishment vs Maintenance	Recommendation
1		Bogie wheels	Refurbishment	Excessive wear on diameter and flanges. All wheels to be replaced Missing drive covers to be replaced Machine Rail clamp worn – to be replaced.
2		Bogie wheels	Refurbishment	
3		Bogie wheel	Refurbishment	
4		Bogie mechanisms	Refurbishment	Various leaks on bogie mechanisms. Select 8 x bogey systems for replacement. Old units to be refurbished and reinstalled into machine.
5		Belt drive	Refurbishment	Belt drive motors require a covers Belt drive gearboxes have oil leaks due to missing bolts Belt drive gearbox oil leaks on breather pipe, output side seal and drain pipe Belt drive gearbox cooling fans badly eroded.





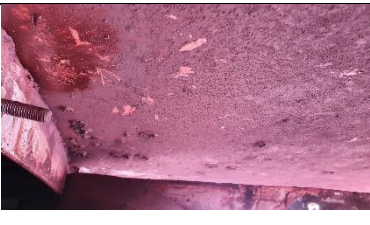

6		Belt drive	Refurbishment	Belt drives are at their useful life and require replacing. Spares to be maintained
7		Belt drive	Refurbishment	
8		Belt drive	Refurbishment	
9		Auto lubrication system	Refurbishment	Auto lubrication system not working and requires to be completely overhauled. Refurbish entire lubrication system (Slew Bearing, Travel Bogey & Pivot, Bucket Wheel, Tripper Car)
10		Belt conveyor idler frames	Refurbishment	Belt conveyor idler frames corroded. Full set of new frames to be installed for Boom, Tripper and incline. 1 x set to be maintained as spares
11		Belt conveyor idlers	Refurbishment	Belt conveyor idlers excessively worn – new frames to be installed complete with idlers

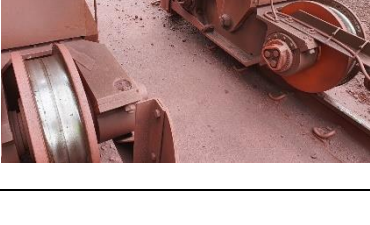
12		Luffing cylinder hydraulics room	Maintenance	Luffing cylinder hydraulics room requires better sealing and filtering to prevent ingress of dirt
13		Luffing cylinder hydraulics	Maintenance	Oil spill tray needs cleaning
14		Luffing cylinder	Refurbishment	Luffing cylinder bottom pivot connection has signs of corrosion. Luffing cylinder to be replaced. Supply and install 1 x luffing cylinder/Manifold Block. Supply as spare 1 x luffing cylinder & Manifold Block together with storage frame and test unit.
15		Luffing cylinder	Refurbishment	Luffing cylinder bottom pin keeper plate bolts corroded
16		Luffing cylinder	Refurbishment	Luffing cylinder distribution block leaking
17		Luffing cylinder	Refurbishment	Luffing cylinder top seal leaking

18		Luffing cylinder	Refurbishment	Luffing cylinder lower access platform knee brace badly corroded
19		Bucket wheel	Refurbishment	<p>Bucket wheel eroded badly with many holes. Bucket wheel has passed its useful life and to be replaced.</p> <p>Remove old Bucket Wheel and replace with complete bucket wheel system including receiving chute. Contractor to match chute to bucket wheel. Once trestles are assembled, installation to be signed by professional engineer to ensure safe execution of works.</p> <p>Refurbish old bucket wheel and receiving chute.</p> <p>Contractor to provide all parts required. This includes for:</p> <ul style="list-style-type: none"> • 8x new buckets/pins, • refurbished gearbox, • new shaft • Drive side (solid) & non drive side (Split) bearings/plumber blocks, • new shrink disc (Bucket wheel and gearbox) • Hubs • Brake system • Lubrication system • PU lining • new torque limiting coupling, • new motor, • All components to be assembled and complete bucket wheel with weather protection to be kept on site as a spare.
20		Transfer chute	Refurbishment	Transfer chute eroded badly and requires replacing
21		Slew drives	Refurbishment	<p>Slew drives require covers. All slew drives to be replaced as obsolete.</p> <p>Replace complete set of 3x slew drives (including alignment), inclusive of drives, shafts, gearboxes, motors, reducers and pinions and spillage covers for the motors. Spares to be maintained due to change in gear ratio</p>

22		Slew drive	Refurbishment	Slew drive mounting bolts are short and requires sealing
23		Slew drive	Refurbishment	Slew drive bottom flange bolts loose
24		Slew drive	Refurbishment	Slew drive bearing housing badly corroded
25		Slew drive	Refurbishment	Slew drive bearing housing top flange nuts missing
26		Slew Drive	Refurbishment	Oil and water leaks to be prevented as they cause corrosion inside the cage
27		Slew Drive Pinion	Refurbishment	Lubricating pinion is dry and mis-aligned badly. No lubrication being applied. Entire lubrication system to be refurbished. Alignment part of new installation

28		Slew Drive Pinion	Refurbishment	
29		Slew Drive Pinion	Refurbishment	
30		Boom Tip	Refurbishment	Pitting corrosion evident on bottom face of top section Boom tip eroded and corroded. Boom tip to be replaced along with wear bar.
31		Boom tip	Refurbishment	
32		Bucket wheel drive	Refurbishment	Bucket wheel drive has a few oil leaks. Bucket wheel to be replaced. Old system to be refurbished.
33		Tripper car wheels	Refurbishment	Tripper car wheels worn. All wheels to be replaced

34		Tripper car tail conveyor pulley guard	Maintenance	Tripper car tail conveyor pulley guard has holes which causes spillages. Maintenance issue
35		Tripper car conveyor drive motor	Refurbishment	Tripper car conveyor drive motor needs a cover. There is a build up of dirt inside the fan housing. Motor termination box corroded as well. Motors at end of life and require replacing
36		Tripper car cable reel drive	Refurbishment	Tripper car cable reel drive issues with coupling key. System requires replacing
37		Tripper car water hose reel	Refurbishment	Tripper car water hose reel not functional and requires replacing Like for like replacement with new. VSD, funnel system and hose included.
38		Tripper car conveyor head end	Maintenance	Tripper car conveyor head end has holes in the casing that is causing excessive spillages
39		Tripper car conveyor head pulley scraper	Maintenance	Tripper car conveyor head pulley scraper sides require sealing to prevent spillages



**Mechanical Assessment
BTS Refit Project, Phase 4 – SR3**

TPT BTS VCA – SR3

Revision 01

Project No: Z.5200160

Date: 13/07/2021 | Page 8 of 8

40		Dust suppression system	Refurbishment	Dust suppression system needs to be refurbished and activated
41		Containers	Refurbishment	6 x 12ft containers to be supplied to house spares and parts required for refurbishment.
42		Fire Escape System	Refurbishment	Request from BTS to install a connection/anchor point onto cabin platform taking into account the loads and structural support required.

No	Engineering Discipline: Structural Description/Recommendation	Picture reference
1	<p align="center">Stacker Reclaimer:</p> <p>Corrosion of steel structure. Corrosion protection to be applied as per TPT's specification Allowance to be made for 350 square meters corrosion protection, to be re-measured during execution. Estimation based on previous Phases of the Refit Project for work carried out on identical machines.</p>	 <p align="center"><i>Lower support structure to operators cabin</i></p>  <p align="center"><i>Slew deck walkway support</i></p>  <p align="center"><i>Jackstay lower connection</i></p> 

Boom upper support structure



Boom upper support structure connection



Boom upper support structure connection



Boom upper support structure connection



Boom upper support structure connection



Boom upper support structure



Boom upper support structure



Boom upper support structure



Boom upper support structure connection



Boom upper support structure connection



Boom upper support structure connection



Boom upper support structure



Boom upper support structure connection



Boom upper support structure connection



Jackstay lower catladder connection



Boom walkway structure splice connection





Mast walkway connection



Mast walkway connection



Lower luffing cylinder connection



Mast walkway connection



Mast walkway connection



Mast walkway connection



Mast catladder connection



Upper luffing cylinder connection



Upper portion of luffing cylinder



Counterweight frame



Counterweight frame pivot connection

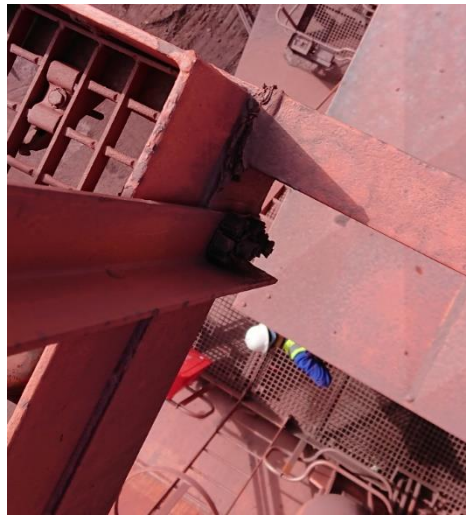

Mast walkway



Counterweight frame catladder connection



Counterweight frame catladder

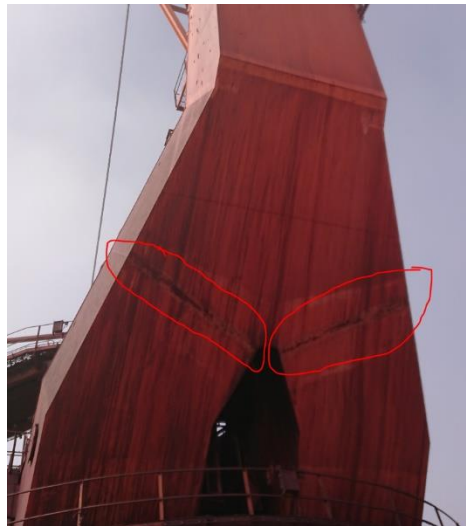

Back of mast



Underside of slew deck



Operators cabin support structure



Operators cabin support structure



Slew drive housing



Inside slew deck

2

Stacker Reclaimer:
Corroded nuts and bolts. Make an allowance for 200 bolts to be replaced like for like.



Boom walkway stanchion connection



Boom walkway stanchion connection



Boom upper support structure connection



Boom upper support structure connection



Boom walkway stanchion connection



Luffing cylinder lower pivot connection



Luffing cylinder upper pivot connection



Mast walkway stanchion connection



Counterweight frame structural connection



Underside of gantry







Slew drive mounting bolts



Slew drive mounting bolts



Operators cab luffing cylinder upper connection bolts

<p align="center">3</p>	<p align="center">Stacker Reclaimer:</p> <p align="center">Loose bolts – Maintenance activity.</p> <p align="center">Drives are obsolete and require replacing</p>	 <p align="center"><i>Slew drive bottom flange bolts</i></p>  <p align="center"><i>Slew drive bottom flange bolts</i></p>
<p align="center">4</p>	<p align="center">Stacker Reclaimer:</p> <p align="center">Missing bolts and nuts. Maintenance activity. Luffing cylinder to be replaced as part of the refurbishment</p>	 <p align="center"><i>Luffing cylinder lower pivot connection</i></p>  <p align="center"><i>Slew drive bottom flange</i></p>



Inside slew deck – nut missing

5

Stacker Reclaimer:

Bent / broken gusset plates below slew ring gear. Additional damage since last inspection. Structural budget increased to accommodate repair



6

Stacker Reclaimer:

Eroded bucket wheel and receiving chute. Bucket wheel & Receiving chute to be replaced as part of the refurbishment



Bucket wheel

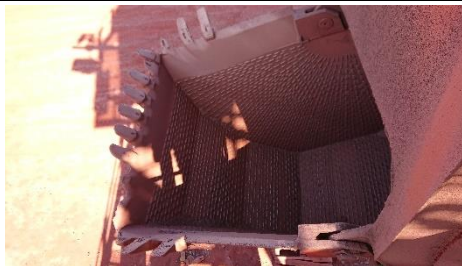

Bucket wheel bucket

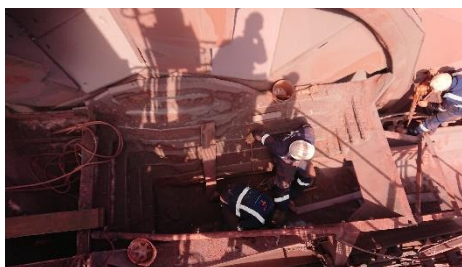



Receiving chute

7

Stacker Reclaimer:
Eroded boom tip structure.
Boom tip to be replaced along
with wear bar

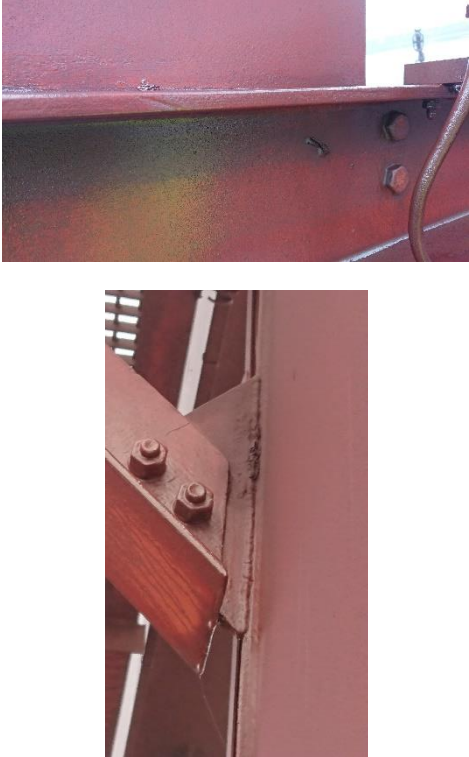

		
<p align="center">8</p>	<p align="center">Stacker Reclaimer: Broken ladder rung (access ladder to slew bearing). Ladder to be repaired.</p>	
<p align="center">9</p>	<p align="center">Tripper Car: Corrosion of steel structure. Corrosion protection as per Stacker Reclaimer. Allowance of 350m² for Stacker Reclaimer including Tripper Car</p>	

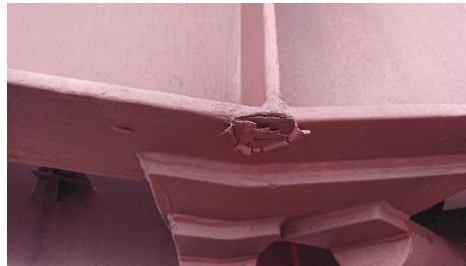



10

Tripper Car:

Corroded nuts and bolts. 200 bolt allowance made for Stacker Reclaimer and Tripper Car based on replacement on previous phases to identical machines.



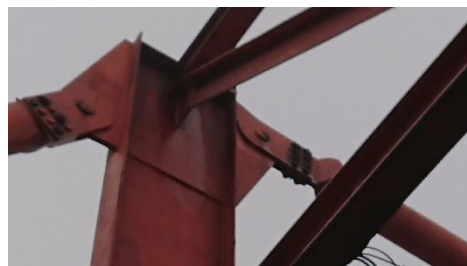
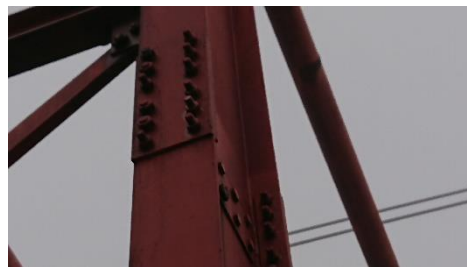
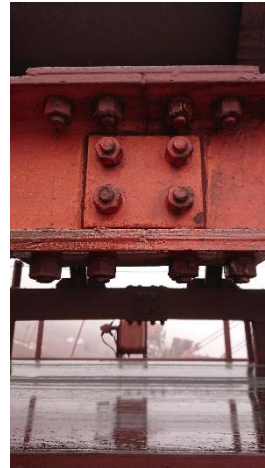









11

Tripper Car:
Peeling and damaged paint.
Corrosion protection allowance
made in scope of works

<p align="center">12</p>	<p>Stacker Reclaimer & Tripper Car:</p> <p>Excessive material build-up on roof structures, causing overloading of these structures.</p> <p align="center">Maintenance activity</p>	
<p align="center">13</p>	<p>Tripper Car:</p> <p>Incline conveyor head pulley: Cover damaged. Maintenance activity</p>	

<p align="center">14</p>	<p align="center">Tripper Car:</p> <p>Incline conveyor head pulley: Skewed bolts & support structure damage. Included in structural repair allowance</p>	
<p align="center">15</p>	<p align="center">Tripper Car:</p> <p>Tripper bend pulley support structure damage. Included in structural repair allowance</p>	
<p align="center">16</p>	<p align="center">Tripper Car:</p> <p>Idler support frame end caps missing (material build-up and water ingress leading to corrosion). Frames to be replaced as per the refurbishment scope of work</p>	

	Structural Assessment BTS Refit Project, Phase 4 – SR3	Revision 01	
	TPT BTS VCA – SR3	Project No: Z.5200160	
		Date: 13/07/2021	Page 25 of 25

The following is noted:

1. Assessment items and photographs are representative samples of the typical issues identified and may not necessarily represent each individual case e.g. Corroded bolts and nuts: Due to the widespread nature of this item a photograph of every corroded bolt has not been included, only representative photographs included. Allow for 200 bolts/nuts to be replaced and re-measured during execution. Allow for 350m² of corrosion protection as per Transnet Specification. Works to be re-measured during execution.
2. Due to the dirty nature of the machine and the amount of spillage it is possible that not all structural defects were observed. It is recommended that a re-inspection be conducted once the entire machine has been thoroughly washed (high pressure cleaning) and cleaned of all iron ore dust and spillage, so that any possible additional defects can be observed. Corrosion protection to be re-measured during execution
3. The findings listed in this report are based on a visual inspection of the machine. It is recommended at NDT testing be conducted on welds in high stress areas to verify the condition of the welds. Boom high stress areas as indicated on the GA layout are included within the drawing pack available to the Principal Contractor
4. It is also recommended that a 3D scan of the boom and counterweight structures is conducted and evaluated to determine if there are any abnormal deflections/alignment issues.



Provision of Service to refurbish dust suppression System

SR1 & 3

WORK SPECIFICATION

Document Reference Number:

BTSPE-SIT-WS-18022021

Site:

Bulk Terminal Saldanha

Date:

February 2021

*Distribution of this document is restricted to Transnet and
Transnet approved entities only*

TABLE OF CONTENT

1.DEFINITIONS.....4

2.ABBREVIATIONS.....6

3.BACKGROUND7

4.OBJECTIVES.....7

5.SPECIFICATION/SCOPE OF WORK7

5.1 THIS RFQ IS FOR THE REFURBISHMENT OF THE DUST SUPPRESSION SYSTEM AT THE IRON ORE STACKER RECLAIMERS. 7

5.2 FROM PUMP TO DUST SUPPRESSION SYSTEM..... 8

5.3 FROM HOSE REEL TO TANK..... 8

5.4 FROM PUMP TO DUSTEX CONTROL PANEL TO TRIPPER CAR HEAD CHUTE . 8

5.5 FROM PUMP TO INCLINE CHUTE 8

5.6 FROM TRIPPER CAR TO A BOOM TAIL DUSTEX CONTROL PANEL..... 8

5.7 BOOM TAIL TO B/W CHUTE..... 9

6. TESTING & COMMISSIONING9

7.QUALITY AND SERVICE.....9

8.TECHNICAL REQUIREMENTS9

9.GENERAL SAFETY AND COMPLAINE SPECIFICATIONS11

10. ANNEXTURE13

10.1 TPT-IMS-SLDT-CL-014-001.1 Contractor COVID 19 SHE File Assessment Checklist.....13

**10.2 TPT-IMS-SLDT-GDL-014-001.2 Guide -Contractor COVID 19
Work Plan13**

1. DEFINITIONS

Commissioning:

The process of assuring that all systems and components of a building or industrial plant or product designed, installed, tested, operated, and maintained according to the operational requirements of the owner or final client.

Contract

An agreement with specific terms between two or more parties or entities based on mutual consent, which has legal effects and involves transfer of consideration – usually financial or some other type of benefit.

Contract Manager

Transnet employee who is authorised to represent Transnet in terms of the contract and appointed to supervise and/or liaise with the contractor to ensure that the specifications of the contract met (with special emphasis on technical specifications, inspection of quality, on health and safety, environment and quantity of work). A contract manager has the role of executing the plan to achieve the deliverables. This person receives all his authorisations from the project initiator and the stakeholders.

Contract Owner

The person who requires a specific product, goods or services and who is responsible to provide the budget and approval.

Contractor

An employer (organisation) or a person performing any work and has entered into a legal binding business agreement contract to supply a product or provide services to Transnet. This applies to the Suppliers, Vendors, and Consultants, Service providers and Contractors.

Contractor Execution Plan

A site, activity or project specific documented plan in accordance with the client's project requirements. The Contractor to Transnet submits a plan for approval prior to

mobilization on site. The Contractor Execution Plan includes, inter alia: Health and Safety, Environmental, Energy, Quality, Delivery plans etc.

Contractor Compliance File a file or other record containing the information in writing required by Transnet.

NB: A file must be submitted for each discipline where applicable e.g. health and safety, environment file etc.

Job Owner:

Any permanent employee of BTS who been trained, tested and found competent, and appointed in writing for the purpose of carrying out or supervising work on plant, machinery and equipment.

Risk Assessment

A risk assessment in this procedure means the process where all risks associated with the contract and its execution identified, mitigated and managed.

Specification

A detailed prescription of the Integrated Management System (IMS) requirements to which equipment, construction, product or service has to comply with this includes various models, drawings and documents. It noted that the specification might even comprise of a multitude of different elements.

Lockout:

The fitting of a padlock (or calliper and padlocks) to an isolator switch so that it cannot be returned to an operating condition.

Permit Acceptor:

Any person who has been appointed in writing to receive a Permit to Work for the purposes of carrying out or supervising work on equipment.

Permit Issuer:

The operations shift manager will be responsible for the issuing of permits.

Permit Number:

A number issued by CCR that logs the work performed, the person responsible for the work and the approximate duration. Note: This is not the same as the sequential number on the Permit to Work.

Permit to Work:

A written document indicating the equipment to work on, the potential hazards, how and where these hazards negated, signatures indicating that equipment is safe and the names of all persons working on the equipment.

Responsible Supervisor:

The Operations and Maintenance Supervisor who been assigned responsibility for the operation and maintenance of a particular section/s of the plant.

2. ABBREVIATIONS

IMS:	Integrated Management System
ISO:	International Organization for Standardization
OHSAS:	Occupational Health and Safety Assessment Series
POM:	Policy Manual
PROC:	Procedure
SOP:	Safe Operating Procedure
QMS:	Quality Management System
SANS:	South African National Standard
SMS:	Safety Management System / Service Management System
TCC: Office	Transnet Corporate Centre which is the Transnet Head
SLD:	Saldanha
TPT:	Transnet Port Terminals
WI:	Work Instructions

3. BACKGROUND

Transnet Port Terminals (TPT), Port of Saldanha requires a suitably qualified and competent Service Provider to refurbish dust the suppression system for the stacker reclaimer machines. (SR1 & SR3)

4. OBJECTIVES

To eliminate and control dust in all areas of the stacker reclaimer machines as part of TPT dust emission management plan and to comply with Air Quality Act, 2004 (Act No. 39 of 2004) as mandated by National Dust Control Regulations

5. SPECIFICATION/SCOPE OF WORK

5.1 This RFQ is for the refurbishment of the dust suppression system at the Iron Ore stacker reclaimers.

- 5.1.1 Service providers must refurbish Dust suppression system at SR1 & SR3
- 5.1.2 The service provider shall schedule his work such that it does not interfere with the Terminal Existing operations.
- 5.1.3 The work must be planned around the 12 hour maintenance windows which is on a Tuesday, Wednesday and Thursday each week (subject to change), to be communicated by the technical supervisor.
- 5.1.4 The service provider shall make its own assessment of the problems and difficulties which may be encountered for providing access to and interfacing with others (this includes access difficulties experienced during construction or commissioning phase)
- 5.1.5 The Contractor shall provide at his/her own cost any security measures he/she may deem necessary for safe and effective execution of the work within the contract area.
- 5.1.6 The service provider shall inform the Project technician on a daily basis with regards to the detailed project plan of his progress and any deviations & defects.
- 5.1.7 An effective safety procedure to be followed by all personnel on any TPT work site shall be compiled by the service provider and implemented before any work commences,
- 5.1.8 The procedure shall be updated whenever the need arises and any changes shall be communicated to all employees on a work site before work proceeds
- 5.1.9 The service provider shall come on site with all the relevant tools and consumables for executing the job
- 5.1.10 The service provider shall only work on the equipment after being issued with a permit to work by the technical supervisor.
- 5.1.11 The service provider may be working where other contractors and maintenance personnel perform other works, which are in the same area during the duration period of this contract.
- 5.1.12 The service provider shall co-ordinate his work with the Project technician to maintain harmonious working conditions on site.

- 5.1.13 The service provider shall provide Protective Equipment (PPE) for his/her employees.
- 5.1.14 The service provider shall ensure that his/her employees at all times exercise care and consideration for the fauna and flora within and adjacent to the work area
- 5.1.15 The service provider shall commence during a maintenance window and will be allowed to work from 07:00 to 17:00, while the machine is out of production.

5.2 From pump to dust suppression system

- 5.2.1 Supply and install water filtration system. (**For specification see Annexure attached**)

5.3 From hose reel to tank

- 5.3.1 Replace all steel pipes with stainless steel piping,
- 5.3.2 Replace current relief valve with 2 inch inline relief valve settings (0-3bar),
- 5.3.3 Fit gauge in(0-16 bar)
- 5.3.4 Fit 2 inch blow-off valve
- 5.3.5 Replace 3-inch steel pipe from tank with 3-inch stainless steel pipe.

5.4 From Pump to dustex control panel to tripper car head chute

- 5.4.1 Replace 2-inch steel pipe with 2-inch stainless steel pipe,
- 5.4.2 Supply and install check valves and ball valves
- 5.4.3 Replace rusted dustex control panel (400 x 400) with stainless steel box
- 5.4.4 Replace pressure regulator and solenoid. (**spec see annexure attached**).l
- 5.4.5 Replace ½ inch steel pipes with stainless steel pipes
- 5.4.6 Replace ½ inch hose pipe with push-lock hose pipe
- 5.4.7 Replace all ball valves and non-return valves inline
- 5.4.8 Replace current spraying system with manifold with eight spray nozzles.

5.5 From pump to incline chute

- 5.5.1 Replace steel pipe with 2 inch stainless steel pipe
- 5.5.2 Replace/supply all ball valve and non-return valves
- 5.5.3 Current spray system to be supplant with manifold with eight spray nozzles
- 5.5.4 Replace pressure regulator and solenoid valve
- 5.5.5 Supply and install stainless steel dustex control panel.
- 5.5.6 Replace 1/2 inch steel pipe with stainless steel pipe
- 5.5.7 Replace ½ inch hose pipe with push-lock hose pipe
- 5.5.8 Replace current spraying system with manifold with eight spray nozzles.

5.6 From tripper car to a boom tail dustex control panel

- 5.6.1 Replace steel pipe with 2 inch stainless steel pipe
- 5.6.2 Supply/replace ball valves and non-return valve.
- 5.6.3 Replace 1 ½ inch flexible pipe (0-20bar) with a new hose pipe.
- 5.6.4 Replace dustex control panel box (400 x 400) with a stainless steel box
- 5.6.5 Replace solenoid valve & pressure regular valve(for spec see annexure attached)

5.7 Boom tail to B/W chute

- 5.7.1 Replace steel pipe with 2 inch stainless steel pipes
- 5.7.2 Replace /supply all ball valve and non-return valves.
- 5.7.3 Replace current spraying system with manifold spray systems
- 5.7.4 Replace 2 x dustex control panel box with 400 x 400 stainless steel boxes
- 5.7.5 Replace pressure regulator and solenoid valves

6. TESTING & COMMISSIONING

- 6.1 After completion of the work, the service provider shall satisfy himself that the works is complete in all Respects.
- 6.2 After successful completion of the service provider’s pre-commissioning inspections, the Project Curator shall inspect all works performed by the service provider.

7. QUALITY AND SERVICE

- 7.1 All services supplied and delivered to Transnet must be of excellent quality in compliance with the specifications. Should the goods or service(s) not be in conformity with the specifications, Transnet reserves the right to reject them, obtain the goods or service(s) from other sources of its free choice and debit the difference in cost, if any, to the Service Provider.
- 7.2 The Service Provider must have roadworthy and licenced vehicles.
- 7.3 The service Provider must have a permanently manned telephone (place of business/cell phone) and fax machine, to ensure that immediate contact can be made in case of emergency.
- 7.4 The Service Provider shall ensure that its employees tasked with providing the required services to Transnet are competent, and experienced in carrying out its responsibilities as set out in the scope of work herein.

8. TECHNICAL REQUIREMENTS

The Service provider shall supply the following on the submission of quotation, which will be used for the technical evaluation.

Service Providers evaluated according to the following criteria:

Technical Criteria	% Weightings
<p><u>Experience</u></p> <p>The Service Provider shall be required to have a proven track record in the refurbishment of</p>	<ul style="list-style-type: none"> • 20 % of points=Two (2) written references issued by respondent’s

<p>the dust suppression systems, for a minimum period of two years.</p> <p><u>Supporting documents</u> –Two (2) Written references which shall be used to verify the Service Provider’s previous performance and service delivery. Kindly note that the reference must specifically set out whether the service provider is experienced in the capacities as set out above</p>	<p>client (different clients).</p> <ul style="list-style-type: none"> • 10% of points=One (1) written references issued by respondent’s client (different clients) • 0% of points=Zero (0) written references issued by respondent’s client (different clients)
<p><u>Task Execution time</u></p> <p>Evidence: Confirmation on a company letterhead that the service can be done during Maintenance windows.</p> <p>Lead time to refurbish dust suppression system of Single equipment (eg. SR 1)</p>	<ul style="list-style-type: none"> • 20% of points=Within 5 weeks • 0% of points=above 5 weeks
<p><u>Risk Assessments</u></p> <p>Service Provider must submit a generic risk assessment, based on the works to be executed. The risk assessment should, at a minimum, give detail of the following elements: - safety – health – environment - quality of work.</p> <p>Supporting documents – Risk assessment with all the elements included.</p>	<ul style="list-style-type: none"> • risk assessment covers all 4 elements = 30 points • risk assessment covers 3 of the 4 elements = 15 points • risk assessment covers 2 of the 4 elements = 5 points • risk assessment covers 1 of the 4 elements = 0 points

<p><u>Comply to Scope of Work</u></p> <p>Service Provider must submit a company letter head confirming that the comply to Scope of work</p> <p><u>Supporting documents</u>-Confirmation on Company Letterhead</p>	<ul style="list-style-type: none"> • 30% of points=Written confirmation received • 0% of points=No certification submitted
--	--

The minimum qualifying score required is 60% out of 100

9.GENERAL SAFETY AND COMPLAINE SPECIFICATIONS

- The Contractor must submit a detailed Contractor Execution Plan (CEP) to the Contractor Manager for approval as per **TRN-IMS-GRP-GDL 014.5 Contractor Execution Plan minimum requirements.**
- Contractor must submit **TRN-IMS-GRP-TMP 014.3 Employee Personal Profile Dossier** to contractor Manager for approval before induction training confirmed. Approved Employee Profile Dossiers includes certified copies of medicals, identity documents, competencies etc. submitted via email correspondence to **TPTSLD-Induction-booking@transnet.net.**
- Contractor Compliance SHE File within accordance with File Contractor Compliance File **Approval COVID 19 Checklist TPT-IMS-SLDT-CL-014-001.1 & TRN-IMS-GRP-TMP-014.11** and in line with relevant applicable specifications as per respective **TRN-IMS-GRP-GDL 014.2 Contractor Specification Guidelines, TRN-IMS-GRP-GDL 014.4 Contractor Environmental and Sustainable Specification Guideline, TRN-IMS-GRP-GDL 014.6 Contractor Quality Specification Guideline** and **TRN-IMS-GRP-GDL 014.5 Contractor Security Specification Guidelines**
- Principle contractor approve **Mandatary Agreement** in terms of **section 37(2) TRN-IMS-GRP-TMP-014.1** of the Occupational Health and Safety Act (OHS Act) and submit to Contractor Manager to agree.
- The Principle Contractor must **submit written request** to the Contractor Manager for permission for sub-contract to provide any work or services to TPT and ensure that all **37.2 Agreement between Principle contractor and Sub Contractor** submitted to Contractor Manager.
- Contractor must **submit** completed **SHE File Electronic** to Contractor Manager for approval.
- Contractor undergoes induction training prior to handing over the site to the Contractor as **TRN-IMS-GRP-GDL 014.6 Contractor Induction Minimum Requirements.**
- SITE ESTABLISHMENT:

- All relevant permits and authorisations is as per **TRN-IMS-GRP-TMP 014.7 List of Legal Permits and Authorisations** shared and completed prior to site access. **Contractor appointed** within accordance with **TRN-IMS-GRP-TMP-001.1** prior to site access by TPT.
- Contractor Manager will conduct **TRN-IMS GRP TMP 014.8 Pre-site handover inspection** prior to Site Access grated with Service Provider.
- **No work will commence with approved TRN-IMS-GRP-TMP-014.10 Operational Safe Work Permit** issue to the contractor by Contractor Manager.
- CLOSE OUT PHASE
- Contractor Manager and the Contractor must co-sign the **TRN-IMS-GRP-TMP-014.13 Final Handover and Closeout Inspection Checklist.**
- TESTING AND COMMISSIONING:
- The Contractor Manager will **develop a test and commissioning plan of the project** and communicate it to the contractor.
- The service provider will be responsible for obtaining Hot work permit from TNPA (phone no: 022 703 4331) within conjunction with Fire Safety Management Manual GRM/SHEQ/MAN 001.
- The service provider must have a Fire watch on duty during Hot Work and a Fire extinguisher as per required within Fire Safety Management Manual GRM/SHEQ/MAN 001.
- Service provider will ensure compliance to **TPT SLDT SHEQ-RS PRO 021_Lock Out Procedure** and lock out and isolation done by Trained and competent employees with conjunction with TPT competent.
- Service provider shall implement and maintain applicable Health, Safety, Quality and Environmental regulations and other relevant standards and regulation, example: applicable SANS codes; OHS Act of 1993 , other legislation, ISO 9001, ISO 14001 and ISO 45001, etc.
- Service provider to ensure that all employees involved in activity is informed of the Hazards and risk they exposed to and all other relevant applicable Safety Work Procedures, Fall protections Plans, Environmental Plans, Emergency Plans and any other relevant procedures, etc. proof to be submitted as part of the SHE File.
- Service Provider will ensure that On the Job HIRAS is completed prior to start of activity to ensure that any additional Risks been identified.
- Service provider must ensure that when required to off-load or load any heavy equipment and machinery on the plant that they comply with that equipment or machinery will not be physically operated by an employee when required to off-loaded or load from any flatbed or low bed.
- Principle Contractor will be responsible to ensure that Sub Contractor SHE File compiled within conjunction with TPT Requirements and Approved prior to sub mission to Contractor Manager.
- Service Providers are liable to collect and remove all waste generated during the contract/project. Generated Waste will not allowed being disposed within TPT waste skips. Removal of Hazardous waste will be contractor's responsibility and Disposal Certificate submitted to SHEQ after waste has been disposed safely.

- The Service Provider to ensure full compliance to TPT COVID 19 requirements and Government Safety measures regarding preventing the spread of the COVID 19 virus.

- **Contact the following employees at SHERQ Department:**

- SHERQ Manager IOT: Rejean Viljoen
- Email: rejean.viljoen@transnet.net
- Contact number: 022 703 4958
- SHERQ Manager MPT: Werner Labuschagne
- Email: Werner.Labuschagne@transnet.net
Contact number: 022 703 4945

10. ANNEXTURE

10.1 TPT-IMS-SLDT-CL-014-001.1 Contractor COVID 19 SHE File Assessment_Checklist

10.2 TPT-IMS-SLDT-GDL-014-001.2 Guide -Contractor COVID 19 Work Plan

10.3 Annexure 3: Specification

<p>Compiled: TECHNICIAN</p> <p>Name: Thabiso Moila</p> <p>Signature:</p> <p>Date:15/02/2021</p>	<p>Supported: RELIABILITY MANAGER</p> <p>Name: Shawn Botha</p> <p>Signature:</p> <p>Date:15/02/2021</p>
<p>Supported: SHERQ</p> <p>Name:</p> <p>Signature:</p> <p>Date:</p>	

10.3 Annexure 3: DUST SUPPRESSION SYSTEM SPARES Specification

ITEM NO.	DESCRIPTION	PART NUMBER/ MANUFACTURER	UNIT OF MEASURE	PROJECTED QTY AS AND WHEN REQUIRED
1	WILO-MULTIVERT MVI 812 PUMP (3~400V,EPDM,PN25) NOMINAL MOTOR POWER: 5.5 KW NOMINAL DIAMETER, OVAL FLANGE (ON THE PRESSURE SIDE): G 1½ NOMINAL DIAMETER, OVAL FLANGE (ON THE SUCTION SIDE): G 1½	INFORMATION FOR ORDER PLACEMENTS MAKE: WILO TYPE: MVI 812 ART NO.: 4024741 WEIGHT APPROX.: 58.0 KG	EA	2
2	AXIAL FLOW HOLLOW CONE NOZZLE – SERIES 216 – SPRAY ANGLE - 90°	TYPE: 216.566 – BRASS,G(3/8)	EA	90
3	G ½" PRESSURE REGULATOR COMPLETE WITH AXIAL GAUGE GAUGE Ø 50 MM GAUGE SCALE RANGE: 0 – 1000KPA. GAUGE CONNECTION: 1/4"	PRESSURE REGULATOR PART NUMBER: 2158.04.X0 AXIAL GAUGE PART NUMBER: 832.005	EA	15
4	Filter		EA	2

1		<u>SR3 SIEMENS G120 SOLUTION : 400 VOLTS SYSTEM FOR TRAVEL DRIVES (24X MOTORS 7.5KW EACH)</u>	
1.1	6SL3210-1PE34-8AL0	SINAMICS G120 POWER MODULE PM240-2 FSG C2 WITH BUILT IN BRAKING CHOPPER 3AC380-480V+10/-10% 47-63HZ OUTPUT HIGH OVERLOAD: 200KW FOR 200% 3S,150% 57S,100% 240S AMBIENT TEMP -20 TO +50 DEG C (HO) OUTPUT LOW OVERLOAD: 250KW FOR 150% 3S,110% 57S,100% 240S AMBIENT TEMP -20 TO +40 DEG C (LO) 1000X305X357 (HXWXD), FSG PROTECTION IP20 WITHOUT CONTROL UNIT AND PANEL APPROVED FOR CU FIRMWARE- VERSION V4.7 SP9 AND V5.1	2
1.6	6SL3246-0BA22-1PA0	SINAMICS G120 CONTROL UNIT CU250S-2 DP INTEGRATED PROFIBUS SUPPORT OF VECTOR CONTROL, EASY POSITIONING EPOS VIA EXTENDED FUNCTION LICENSE 4 CONFIGURABLE DI/DO, 6 DI (3 F-DI), 5 DI, 3 DO (1 F-DO), 2 AI, 2 AO SAFETY INTEGRATED STO, SBC, SS1 FURTHER SAFETY FUNCTIONS VIA EXTENDED SAFETY LICENSE ENCODER: D-CLIQ + HTL/TTL/SSI, RESOLVER/HTL VIA TERMINAL PROTECTION IP20 USB- AND SD/MMC-INTERFACE	2
1.7	6SL3054-7TF00-2BA0	SINAMICS G120 SD CARD 512 MB INCL. LICENSING (CERTIFICATE OF LICENSE) V4.7 SP10 HF	2
1.8	6SL3000-2BE35-0AA0	SINAMICS/MICROMASTER PX MOTOR REACTOR FOR 3AC 380-480V, 50/60HZ, 490A AC DRIVES/POWER MODULES/ MOTOR MODULES	2
1.9	6SL3000-1BE32-5AA0	SINAMICS BRAKING RESISTOR INPUT: 600 V DC OUTPUT: 250KW/15S 200KW/20S 2.2 OHM	2
1.10	6SL3255-0AA00-4CA1	SINAMICS G120 BASIC OPERATOR PANEL (BOP-2)	2
1.11	6SL32560AP000JA0	SINAMICS G120 DOOR MOUNTING KIT IP55/ UL TYPE 12 FOR INTELLIGENT OPERATOR PANEL IOP (IP54), IOP-2 (IP55) AND BASIC OPERATOR PANEL BOP-2 (IP55); CONTAINS SEAL FIXING ACCESSORIES AND CONNECTING CABLE (5 M)	2

2		<u>SR3 SIEMENS S120 SOLUTION : 400 VOLTS SYSTEM FOR SLEW DRIVES (3 MOTORS 18.5KW EACH)</u>	
2.5	6SL3100-0BE28-0AB0	SINAMICS S120 ACTIVE INTERFACE MODULE FOR 80KW ACTIVE LINE MODULE INPUT: 3AC 380-480V, 50/60HZ	1
2.6	6SL3130-7TE28-0AA3	SINAMICS S120 ACTIVE LINE MODULE INPUT: 3AC 380-480V, 50/60HZ OUTPUT: DC 600V, 133A, 80KW FRAME SIZE: BOOK SIZE INTERNAL AIR-COOLING INCL. DRIVE-CLIQ CABLE	1
2.7	6SL3120-1TE24-5AA3	SINAMICS S120 SINGLE MOTOR MODULE INPUT: DC 600V OUTPUT: 3AC 400V, 45A FRAME SIZE: BOOK SIZE INTERNAL AIR-COOLING OPTIMIZED PULSE SAMPLE AND SUPPORT OF THE EXTENDED SAFETY INTEGRATED FUNCTIONS INCL. DRIVE-CLIQ CABLE	3
2.8	6SL3040-1MA00-0AA0	SINAMICS CONTROL UNIT CU320-2 DP WITH PROFIBUS INTERFACE WITHOUT COMPACT FLASH CARD.	1
2.10	6SL3054-0FB11-1BA0	SINAMICS S120 COMPACTFLASH CARD WITH FIRMWARE OPTION PERFORMANCE	1
2.11	6SL3055-0AA00-4CA5	SINAMICS OPERATOR PANEL AOP30 LANGUAGE-NEUTRAL WITH MEMORY EXPANSION FOR FIRMWARE V2.4 OR HIGHER!	1
2.13	6SL3055-0AA00-5CA2	SINAMICS SENSOR MODULE SMC30 FOR INCREMENTAL ENCODER: TTL/HTL OR KOMBI ENCODER SSI WITH INCREMENTAL TRACES OR KOMBI ENCODER SSI WITHOUT INCREMENTAL SIGNALS / WITHOUT DRIVE-CLIQ CABLE 30 MM WIDTH	3
3		<u>SIEMENS G130 SOLUTION : 400 VOLTS SYSTEM FOR BUCKET WHEEL</u>	
3.5	6SL3310-1GE37-5AA3	SINAMICS G130 POWER MODULE IP00 380-480 V 3 AC, 50/60 HZ, 745 A TYPE RATING: 400KW 6-PULSE SUPPLY WITHOUT POWER RECOVERY DESIGN CIM INCL. DRIVE-CLIQ CABLE WITHOUT CONTROL MODULE	1

3.6	6SL3000-0CE37-7AA0	SINAMICS LINE REACTOR INPUT: 380-480V 3AC, 50/60 HZ 773A NMA: A5E00125732	1
3.7	6SL3300-1AE32-5BA0	SINAMICS BRAKING MODULE INPUT: 600 V DC OUTPUT: 250 KW/15 S FOR CHASSIS UNITS H AND J	1
3.8	6SL3000-1BE32-5AA0	SINAMICS BRAKING RESISTOR INPUT: 600 V DC OUTPUT: 250KW/15S 200KW/20S 2.2 OHM	1
3.9	6SL3000-2AE38-4AA0	SINAMICS MOTOR REACTOR FOR POWER MODULE/MOTOR MODULE 400/450 KW,	1
3.10	6SL3040-1GA00-1AA0	SINAMICS G130 6SL30401GA001AA0 CONTROL UNIT KIT PROFIBUS	1
3.11	6SL3040-1MA00-0AA0	SINAMICS CONTROL UNIT CU320-2 DP WITH PROFIBUS INTERFACE WITHOUT COMPACT FLASH CARD.	1
3.12	6SL3054-3FB00-1BA0	SINAMICS G130 COMPACTFLASH CARD FIRMWARE-VERSION V5.01	1
3.13	6SL3055-0AA00-4CA5	SINAMICS OPERATOR PANEL AOP30 LANGUAGE-NEUTRAL WITH MEMORY EXPANSION FOR FIRMWARE V2.4 OR HIGHER!	1

TECHNICAL SPECIFICATION

[STACKER RECLAIMER 1 - SR1]

TRANSNET PORT TERMINALS

Z.5200 160 BULK TERMINAL SALDANHA

EQUIPMENT RETROFIT:

BUCKET WHEEL DRIVE VFD

Revision 0.0

**Technical Specification
for
AC Speed
For Stacker Reclaimer # 1**

SECTION 1:**1. GENERAL**

- 1.1 Nominal voltage operation
- 1.2 Voltage tolerance
- 1.3 Maximum ambient operation
- 1.4 Ventilation and cooling
- 1.5 Enclosure rating
- 1.6 Enclosure material
- 1.7 Quality assurance standards

1. PERFORMANCE

- 2.1 Load torque requirement
- 2.2 Technology, motor de-rating
- 2.3 Main voltage compensation
- 2.4 Vector control of the output voltage
- 2.5 Speed holding accuracy
- 2.6 Dynamic braking for overhauling load
- 2.7 Auto tuning of motor parameters
- 2.8 Radio Frequency Interference
- 2.9 Harmonics and power factor
- 2.10 System and motor resonance
- 2.11 Mains starts per hour
- 2.12 Motor reactance coils
- 2.13 Flying start on fans
- 2.14 PID regulator
- 2.15 Motor pre-heat
- 2.16 Cable length
- 2.17 Switching on the output

3. CONTROL AND MONITORING

- 3.1 Galvanic isolation
- 3.2 Input control signals
- 3.3 Noise immunity on digital inputs
- 3.4 Display requirements
- 3.5 Analogue outputs
- 3.6 Relay outputs
- 3.7 Totalizers
- 3.8 Fault display

- 3.9 Serial communication
- 3.10 Serial communication - high performance
- 3.11 24 VDC auxiliary power supply
- 3.12 Safe stop

4. PROTECTION AND MONITORING

- 4.1 VFD shut down
- 4.2 Manual and auto reset
- 4.3. Data log of faults
- 4.4. Electronic thermal overload protection
- 4.5. Thermistor protection
- 4.6. Local repair facilities

SECTION 2:

5. INTRODUCTION to VFD requirements

- This specification has been based on the minimum criteria necessary for reliable operation of A.C. variable frequency drives (VFDs) when used in industrial applications.
- **This specification covers only Constant Torque Applications.**
- Whilst it is widely known that the VFDs provide the highest efficiency and yield the greatest energy savings in speed control of process equipment, other potential problems such as radio frequency interference RFI , harmonic disturbance THD, and poor motor performance can easily offset the potential advantages.
- Full compliance with the specifications may easily be overlooked, especially when there are major differences in price between tenderers offering different solutions, and rectification of the problems later may prove to be time consuming and prohibitively costly.
- The majority of VFDs on the market are based on the PWM principle of operation, however their similarity stops here as development of the output voltage waveform, motor protection, motor performance, RFI and THD reduction methods widely separate the units both in terms of performance and cost.
- The main reason for the additional costs is that, many of the functional features to minimize harmonics and RFI, and to improve control and motor protection are hardware devices which are expensive and take up space inside the control cubicle.
- Many users are unaware of the amount of harmonic distortion the VFDs can produce if they are not fitted with the necessary harmonic reactor coils, and the increase of mains current the VFDs consume if these coils are not fitted.

- Harmonic loads have only proliferated in the past decade, mainly due to the large increase in the use of VFDs, but the knowledge required to maintain clean supplies has not kept up with the technology, with the result that many industrial plants suffer major harmonic problems.
Other important issues such as RFI, galvanic isolation and long motor life are also vital in maintaining a <problem free> plant.
- This specification presents an unbiased view of the technical requirements necessary to ensure high performance and reliability with minimum disturbance to the plant's environmental conditions.

SECTION 3:

SPECIFICATION FOR AC SPEED DRIVE,

6. GENERAL

- The VFDs shall be of the type suitable for controlling the speed of 3 phase, 380V-400V induction motors.
- The VFDs shall be capable of operating continuously at nominated full load rating with expected variations of +/- 10% in the supply voltage and +/- 2% in the supply frequency.
- The VFD shall be capable of operating continuous operation at full load in a maximum ambient temperature of **50°C**, with a 24hour average maximum of 45 °C.
Care shall be taken during installation to ensure that the VFDs are protected from direct sunlight and weather elements.
- The VFDs shall have a ventilation solution that provides total separation of the cooling air circulating through the Heatsink and the air circulating through the electronics section of the VFD, in order to reduce risk of contaminants entering the drive, using principles such as **cold plate technology**, or an externally mounted heat sink, or **preferably back channel cooling**.
 - Where the VFDs are separately wall mounted the enclosure protection rating shall comply with the following guidelines:
 - The environment around the Stacker reclaimer 2 MCC room is subject to moisture and harsh environmental conditions.
 - There are presently measures in place to protect the MCC internal electrical environment against such harsh conditions but from time to time it has been proven inadequate or insufficient.
 - **The VFD shall therefore be protected to IP54 and/or IP66 rating.**
 - There shall be no de-rating of the maximum ambient temperature for an IP54 and/or IP66 enclosure.

- The enclosures shall be constructed in mild steel to prevent the radiated radio frequency interference noise (RFI) from affecting the operation of other equipment.
- The metal enclosures must be earthed with a low impedance connection to the main earthing system.
- The VFDs shall be manufactured to quality assurance and manufacturing standards according to ISO 9001.

7. PERFORMANCE

- The VFDs shall be specifically designed for **constant torque operation**; but shall also incorporate a choice of output waveforms designed to control quadratic loads to give the VFD flexibility over a wide application area.
- The tenderer shall state the kVA output power of the VFDs in both constant and quadratic torque loads.
- In constant torque mode the VFDs shall be capable of supplying a starting torques of up to 150%-160% of the motors rated torque.
- The VFDs shall be of the type utilizing advanced digital PWM technology.
- Preference shall be given to systems where the output waveform is sinusoidal at all frequencies, such that the motor power is fully utilized at the motors rated speed, and no motor de-rating is necessary.
- Suppliers will have to show a test of the motor's temperature rise with operation, where the motor is operated at full load and speed, shall be seen to be suitable proof. The test shall be based on a class B temperature rise on class F winding insulation.
- If de-rating is applicable the tenderer shall supply curves showing the necessary de-rating of the motor, using class B temperature rise, should be given at rated speed and load to ensure that no overheating occurs.
- The VFDs shall automatically correct the output voltage during main's variations of +/- 10% to prevent loss of torque and speed variations occurring during motor operation.
- **To prevent over-magnetization of the motor at low speeds and light loads the VFD shall incorporate automatic flux control of the motor.**
- **A single fixed voltage boost that cuts out a predetermined frequency will not be considered as automatic control of the flux.**
- The VFDs shall automatically adjust the output frequency and voltage to maintain a stable motor speed of +/- 0.5% of the motor's rated speed.

- The accuracy shall be maintained over a speed and loading range of 10% to 100% without the use of a closed feedback loop.
- **Where the VSDs are specified to control overhauling loads it shall be fitted with a dynamic brake option.**
- **Only Non-Regenerative VFDs to be considered.**
- In this specific Application, the cost in energy lost to heat generated during regenerative operation compared to the savings in energy returned to the Grid when using Full Regenerative Drives is comparatively small and cannot justify the initial capital layout to consider a Full Regenerative solution.
- **A separate external braking resistor** shall be supplied rated according to the duty cycle required for this Application, the Tenderer to supply with the tender the Braking power and duty cycle.
- This Braking Resistor <<Elements>> must have a minimum IP2x Degree of Protection Rating.
- The Braking Resistor to be galvanically separate from the <Resistor elements> and be named the <<Terminals Enclosure>> this enclosure section must have a minimum IP54 Degree of Protection Rating.
- The Braking Resistor <<Elements>> cubicle must use natural ventilated by means of natural convection, (No Forced cooling must be considered).
- The Braking Resistor enclosure must be manufactured from 304 Stainless steel.
- The Braking resistors will be installed outside the MCC Room (Drives room) in the vicinity of the MCC to minimize cable lengths
- A rain preventive Canopy should be installed over the Braking resistor enclosure.
- The VFDs shall incorporate automatic tuning and setting of the main motor parameters. The tuning shall be based on measurements of the motor's inductance and resistance. The tuning must be done at standstill in order not to affect the application before the VFD is tuned.
- The automatic tuning shall stop and register an alarm condition if the automatic tuning detects an out of balance in the motor windings or cannot set the correct parameters for the motor.

8. **Radio Frequency Interference (RFI):**

- Tenderers are reminded that the plant contains equipment sensitive to RFI interference (such as PLCs and Computers).
- Full compliance to the standards is requested. The VSDs should be well protected and immune to electrical disturbance in order to ensure high reliability
- The VFDs shall comply with the EMC immunity standards:
- **EN 61000-4-2 (IEC 1000-4-2): Electrostatic discharges (ESD)**
Simulation of electrostatic discharge from human beings.
- **EN 61000-4-3 (IEC 1000-4-3): Incoming electromagnetic field radiation, amplitude modulation.**
Simulation of the effects of radar and radio communication equipment as well as mobile communications equipment.
- **EN 61000-4-4 (IEC 1000-4-4) Burst transients.**
Simulation of transients brought about by switching with a contactor, relays or similar devices.
- **EN 61000-4-5 (IEC 1000-4-5) Surge transients.**
Simulation of transients brought about e.g. by lightning that strikes near installations.
- **ENV 50140: Incoming electromagnetic field, pulse modulated.**
Simulation of the impact from GSM telephones.
- **ENV 50141: Cable-borne HF.**
Simulation of the effect of radio transmission equipment connected to supply cables.
- **VDE 0160 class W2 test pulse: Mains transients.**
Simulation of high-energy transients brought about by main fuse breakage, switching of power factor correction capacitors, etc.
- The VFDs shall comply with the EMC emission standards:
- **EN 55011 Class A1: Cable born from (150Khz-30Mhz). Radiated (30Mhz-1Ghz.)**
The VFDs must comply to EN 55011 Class A with 150 m of screened/armoured cable.
- The VFDs shall be fitted with metal enclosures (to form a Faraday Cage) to limit the radiated RFI noise from the VFD.
- The VFDs shall be earthed to the main earth grid with a low impedance connection.

9. RFI Filters

- Where RFI filters are supplied from a separate supply source, documentation showing the test results of the RFI and VFD combination and its compliance to EN55011 shall be supplied as evidence of conformity including the maximum length of cable.
- The separate RFI filters shall be mounted in metal enclosures to the same protection rating as the and located as close to the mains connection terminals of the as possible.
- Ferrite cores mounted on the input cables will not be considered as RFI compliance.

10. Harmonics and Power Factor

- Tenderers are reminded that the plant contains a high portion of harmonic producing loads. The information requested in this section of the specification is important for the evaluation of the total plant's harmonic distortion limits.
- Mains Harmonic currents generated by the VFDs must be limited by external mains reactors OR reactors in the D.C. bus of the VFD. Preference shall be given to VFDs that include reactors in the D.C. bus circuit.
- VSDs that do not include a reactor mounted in the D.C. bus shall be supplied with external three phase reactors connected on the mains side of the VFD. The reactors shall be fitted to each phase and shall have a minimum impedance of 5%. The reactors shall be mounted in steel enclosures to a rating equivalent to the .
- When external three phase reactors are supplied Tenderers shall include the amount of voltage drop that will occur over the reactors at full load and advise how the VSD will respond to the lower voltage.
- When both external input reactors for harmonic reduction and output reactors are fitted the tenderer shall state the amount of expected de-rating which will occur on the motor when running at rated speed and load.
- Tenderers shall include a spectrum of harmonic generating currents in the 1st-25th harmonic range and shall state both the $\cos \phi_1$ and the power factor of the at 100% load.
- Calculation of the power factor must be based on the ratio of the fundamental current, and its displacement from the voltage, to the total RMS current which includes all harmonic currents up to and including the 25th.
- $\cos \phi_1$ will not be accepted as power factor as it only applies to power factor in loads which draw a sinusoidal current.
- In order to eliminate any system resonance occurring within the motor's operating frequency range, the VFDs shall be provided with several bypass frequency adjustments. The bandwidth shall be adjusted as a percentage of the recorded by-pass frequencies.

- High efficiency motors are used therefore the VFDs must have a built-in anti-resonance algorithm in order not to cause resonance in the system.
- The VFDs shall be suitable for the control of high inertia loads and be able to catch a rotating motor under any operating condition without tripping. Whether through large supply interruptions, or by the action of switching on and off the motor isolating switch when the motor is running.
- The function shall also ensure that a motor on a high inertia load already pre-rotating, even in the reverse direction, can be switched onto, braked to zero speed by D.C. injection braking incorporated in the VFD and then accelerated to the preset speed in the correct direction.
- The VFDs shall incorporate a PID regulator to enable closed loop control of the process. The regulator shall operate in conjunction with the ramp adjustments to allow smooth acceleration into regulation. Remote monitoring of the feedback signal via a 0/4 - 20mA signal from the VFD is required.
- To prevent condensation, build up in the stator The VFDs shall incorporate a pre-heat function. When the motor is stopped it shall receive a low D.C. voltage from the .
- **VFDs shall be capable of allowing motor cable runs of up to 300 meters** with an un-screened / unshielded cable and 150m with a screened / shielded cable.
- If the VFDs cannot allow these cable lengths, the tenderer shall state the maximum cable length allowed, and the motor coil reactance value intended to be used to increase the cable length. The tenderer shall state clearly the voltage drop and additional motor de-rating that will occur when motor reactors are fitted.
- **The VFDs shall be suitably protected to allow for switching to take place on the output via, a contactor or isolating switch without damage to the VFD inverter block transistors (IGBTs).**

11. CONTROL AND MONITORING:

- All VFD's analogue and digital control inputs and outputs shall be galvanically isolated from each other and from the mains supply and shall be capable of withstanding a test voltage of 2.5 kV dc for 1 sec. For safety reasons, only that have galvanic isolation as an integral part of the VFD will be accepted.
- The VFDs shall respond to speed commands from 0-10 V dc, 2-10 V dc 1-5 V dc and 0/4-20 mA control signals, and their respective inverted signals.
- **For maximum noise immunity on the digital inputs the sink current shall be minimum 10 mA and 24 V for each input. The internal power supply for the supply to the digital inputs shall have a minimum capacity of 200mA at 24V.**

- The VFDs shall have an alpha-numeric display and shall provide comprehensive information on the VFD regarding the motor condition. The following is considered as minimum requirements:
 - a. Reference % of control signal
 - b. Frequency Hz
 - c. Display of feedback signal
 - d. Current Amps
 - e. Torque %
 - f. Power kW
 - g. Energy kWh
 - h. Output voltage V
 - i. D.C. voltage V
 - j. Motor thermal reserve %
 - k. Inverter thermal reserve %
 - l. Monitoring of the Status of the Digital Inputs & Outputs
 - m. Monitoring of the Status of the Analogue Inputs & Outputs
- The tenderer shall state clearly which displays are available, whether the VFD can display the parameters mentioned above and what alternative methods can be used if the VFD cannot display these parameters.
- One programmable analogue output shall be provided for monitoring. A choice of 0-20 mA and 4-20 mA shall be provided. The programmable options shall include as a minimum Hz, Amps, and Torque.
- A minimum of two programmable relays shall be provided for remote monitoring of the VFD. The programmable options shall include as a minimum VFD Ready, VFD running and VFD Trip alarm. The contacts shall have a minimum rating of 250 V, 2A ac. The VFD run relay function shall initiate a run signal only when the frequency output from the VFD is greater than 0.5 Hz.
- The VFDs shall incorporate the following totalizers.
 - n. Hour run meter
 - o. Kilowatt Hours
- The VFDs shall display all faults in clear English text. The following is considered as minimum requirements.
 - p. Inverter fault
 - q. Over voltage/Under voltage
 - r. Over current
 - s. Ground Fault
 - t. Over Temperature
 - u. Overload
 - v. Motor Trip

- **The VFDs shall incorporate English text, the Faults may not be distinguishable only through a code system.**
- The VFD shall preferably be fitted with a USB serial port and be supplied with suitable software utilizing a windows environment to display all monitoring, fault, alarm and status signals. The software shall allow parameter changes to be made to the VFD's settings by uploading the data from the VFD, changing the parameters, and then downloading the data to the VFD again. Storage of each 's operating, and set-up parameters shall be able to be stored outside the VFD's environment.
- The VFDs must have a facility to <Download> or <Upload> the Parameters from and to the VFD's Keypad / HMI Panel.
- The VFD shall have provision to accept an option card for high speed serial communication. PROFIBUS, PROFINET, Ethernet, Modbus RTU, Modbus TCP/IP, ControlNet or DeviceNet are accepted fieldbus standards.
- The design should be such that an external 24 Volt supply can be connected to maintain operation of the microprocessor and serial communication bus during the loss of AC Mains Voltage.
- The VFDs shall preferably be supplied with safe stop functionality suitable for category 3 installations as defined by **EN 954-1** and **SIL 2/IEC 61508** this feature will prevent a drive from starting accidentally.

12. PROTECTION AND MONITORING

- The VFDs shall shut down safely under the following conditions and operate the alarm relay. The 's display shall indicate the nature of the fault in clear English text.
 - Over voltage
 - Under voltage
 - Over current
 - Earth fault
 - Over Temperature
 - Overload
 - Motor trip
 - Inverter fault
- The VFDs must not be destroyed by a short or an earth fault on the output neither by switching on the output.
- The VFDs shall provide for both automatic and manual reset operation. Automatic reset shall only operate on over current and over and under voltage. In automatic mode there shall be a programmable choice of up to 10 reset attempts per fault before the VFD shuts down making manual reset necessary to restart the system. The restart time after a trip in automatic mode shall be adjustable.

- For safety reasons the VFDs must have a trip lock function preventing an operator resetting the VFD under extreme conditions.
- In manual reset mode the reset shall be accomplished from both the keypad on the VFD and by remote signal.
- The VFDs shall be equipped with a data log menu that will allow storage of the type of faults that have occurred. Last fault memory shall be required in the event of power failures.
- The VFDs shall also incorporate a TRENDING facility allowing for several parameters (at least 5) to be trended in real time.
- The VFDs shall include electronic motor thermal overload protection where the trip time is based on the motors running frequency, actual motor current, operating time and the motors rated current. The device shall automatically modify the trip time to consider operation at low speed. On trip the VFDs shall indicate that the fault is a motor thermal trip.
- The VFDs shall include a motor PTC thermistor input for use when motors are fitted with thermistors and shut down the motor when the PTC resistance value increases above its safe operating value. On trip the VFD shall indicate that the fault is a motor thermal trip.
- The tenderer shall state whether **full repair facilities** are available, and in which local Provinces/Cities they are located.

13. BUCKET WHEEL VFD SIZING:

13.1. 1 x Single Bucket Wheel VFD, suitable to Control 1 x 355kW motor.

- MCCB Rating= 1000A
- Motor kW= 355kW
- **Minimum VFD Rating @ Constant Torque= 400kW @ 400V AC**
- VFD to have Built-in Braking IGBT facility continuously rated able to dissipate the full VSD Power rating.
- Input Line Semi-conductor protection fuses with Trip indication
- Input Line 3 Phase AC Reactor, or DC Bus DC reactor
- Braking Resistor
- Alphanumerical Keypad display mounted on the Door with extension cable.
- Profibus card
- Control circuitry
- Indication Pilot lights on the door, VFD Healthy, Running and Tripped
- Other requirements as stipulated above in this document.

13.1.1. VFDs Control Philosophy:

- The VFD drives the Bucket wheel 355kW motor in Open loop.
- Consideration is required regarding the total length of the motor cable(s) from the VFD to the Bucket wheel motor.

- 3 x PT100 motor windings temperature monitoring unit linked to the PLC.

14. VFD Enclosure(s):

- Each VFD to be installed in its own separate Mild steel single or double door floor standing enclosure.
- Material: Frame: 1.5 to 2mm painted steel.
- Door: 2mm painted steel.
- Rear, roof and side panels: 1.35mm painted steel.
- Mounting plate: 2.7 to 3mm galvanized steel.
- Bottom plates: 1mm galvanized steel.
- Frame: Seam welded reversed open profiles with 25mm hole pattern according to DIN 43660.
- Including integrated external hole pattern.
- Door: Mounted with four hinges allowing left- or right-hand opening. Including door frame with 25mm hole pattern.
- Rear panel: Fitted by M6 torx screws.
- Standard facilities for rear door mounting.
- Side panels: Supplied as an accessory.
- Roof panel: Removable.
- Lock: Espagnolette 4-point locking system does not interfere with the enclosure inner space.
- Standard double-bit lock with 3mm pin.
- Can be exchanged for standard inserts or Euro-cylinder and swing handle.
- Bottom plates: Consists of three or four pieces.
- Mounting plate: Double folded and slides into position.
- Adjustable in depth by steps of 25mm with the fastening accessory.
- Earthing: All panels are earthed through their fittings and are equipped with a separate earthing stud.
- Finish: RAL 7035 structured powder coating.
- Protection: Corresponds with IP 56, NEMA 4, 12 and 13.

15. VFD Enclosure Air circulation Channels

These channels must be constructed in such way that the heat dissipated by the heatsink is channeled away from the Front of the VFD where the electronics are installed.

16. Documentation:

Documentation required includes:

Manufacturing general arrangement with all relevant dimensions for installation purposes, Maintenance manual; Final commissioning data sheets as installed.

17. Commissioning:

Commissioning of the VFD to be done by expert personnel familiar with the Application

18. Warranty:

Minimum requirements are; 18 months after shipment date or 12 months from date of commissioning whichever comes first.

TECHNICAL SPECIFICATION

[STACKER RECLAIMER 1 - SR1]

TRANSNET PORT TERMINALS

Z.5200 160 BULK TERMINAL SALDANHA

EQUIPMENT RETROFIT:

SLEW DRIVE(s) VFD(s)

Revision 0.0

**Technical Specification
for
AC Speed
For Stacker Reclaimer # 1**

SECTION 1:**1. GENERAL**

- 1.1 Nominal voltage operation
- 1.2 Voltage tolerance
- 1.3 Maximum ambient operation
- 1.4 Ventilation and cooling
- 1.5 Enclosure rating
- 1.6 Enclosure material
- 1.7 Quality assurance standards

1. PERFORMANCE

- 2.1 Load torque requirement
- 2.2 Technology, motor de-rating
- 2.3 Main voltage compensation
- 2.4 Vector control of the output voltage
- 2.5 Speed holding accuracy
- 2.6 Dynamic braking for overhauling load
- 2.7 Auto tuning of motor parameters
- 2.8 Radio Frequency Interference
- 2.9 Harmonics and power factor
- 2.10 System and motor resonance
- 2.11 Mains starts per hour
- 2.12 Motor reactance coils
- 2.13 Flying start on fans
- 2.14 PID regulator
- 2.15 Motor pre-heat
- 2.16 Cable length
- 2.17 Switching on the output

3. CONTROL AND MONITORING

- 3.1 Galvanic isolation
- 3.2 Input control signals
- 3.3 Noise immunity on digital inputs
- 3.4 Display requirements
- 3.5 Analogue outputs
- 3.6 Relay outputs
- 3.7 Totalizers
- 3.8 Fault display

- 3.9 Serial communication
- 3.10 Serial communication - high performance
- 3.11 24 VDC auxiliary power supply
- 3.12 Safe stop

4. PROTECTION AND MONITORING

- 4.1 VFD shut down
- 4.2 Manual and auto reset
- 4.3. Data log of faults
- 4.4. Electronic thermal overload protection
- 4.5. Thermistor protection
- 4.6. Local repair facilities

SECTION 2:

5. INTRODUCTION to VFD requirements

- This specification has been based on the minimum criteria necessary for reliable operation of A.C. variable frequency drives (VFDs) when used in industrial applications.
- **This specification covers only Constant Torque Applications.**
- Whilst it is widely known that the VFDs provide the highest efficiency and yield the greatest energy savings in speed control of process equipment, other potential problems such as radio frequency interference RFI , harmonic disturbance THD, and poor motor performance can easily offset the potential advantages.
- Full compliance with the specifications may easily be overlooked, especially when there are major differences in price between tenderers offering different solutions, and rectification of the problems later may prove to be time consuming and prohibitively costly.
- The majority of VFDs on the market are based on the PWM principle of operation, however their similarity stops here as development of the output voltage waveform, motor protection, motor performance, RFI and THD reduction methods widely separate the units both in terms of performance and cost.
- The main reason for the additional costs is that, many of the functional features to minimize harmonics and RFI, and to improve control and motor protection are hardware devices which are expensive and take up space inside the control cubicle.
- Many users are unaware of the amount of harmonic distortion the VFDs can produce if they are not fitted with the necessary harmonic reactor coils, and the increase of mains current the VFDs consume if these coils are not fitted.

- Harmonic loads have only proliferated in the past decade, mainly due to the large increase in the use of VFDs, but the knowledge required to maintain clean supplies has not kept up with the technology, with the result that many industrial plants suffer major harmonic problems.
Other important issues such as RFI, galvanic isolation and long motor life are also vital in maintaining a <problem free> plant.
- This specification presents an unbiased view of the technical requirements necessary to ensure high performance and reliability with minimum disturbance to the plant's environmental conditions.

SECTION 3:

SPECIFICATION FOR AC SPEED DRIVE,

6. GENERAL

- The VFDs shall be of the type suitable for controlling the speed of 3 phase, 380V-400V induction motors.
- The VFDs shall be capable of operating continuously at nominated full load rating with expected variations of +/- 10% in the supply voltage and +/- 2% in the supply frequency.
- The VFD shall be capable of operating continuous operation at full load in a maximum ambient temperature of **50°C**, with a 24hour average maximum of 45 °C.
Care shall be taken during installation to ensure that the VFDs are protected from direct sunlight and weather elements.
- The VFDs shall have a ventilation solution that provides total separation of the cooling air circulating through the Heatsink and the air circulating through the electronics section of the VFD, in order to reduce risk of contaminants entering the drive, using principles such as **cold plate technology**, or an externally mounted heat sink, or **preferably back channel cooling**.
 - Where the VFDs are separately wall mounted the enclosure protection rating shall comply with the following guidelines:
 - The environment around the Stacker reclaimers 2 MCC room is subject to moisture and harsh environmental conditions.
 - There are presently measures in place to protect the MCC internal electrical environment against such harsh conditions but from time to time it has been proven inadequate or insufficient.
 - **The VFD shall therefore be protected to IP54 and/or IP66 rating.**
 - There shall be no de-rating of the maximum ambient temperature for an IP54 and/or IP66 enclosure.

- The enclosures shall be constructed in mild steel to prevent the radiated radio frequency interference noise (RFI) from affecting the operation of other equipment.
- The metal enclosures must be earthed with a low impedance connection to the main earthing system.
- The VFDs shall be manufactured to quality assurance and manufacturing standards according to ISO 9001.

7. PERFORMANCE

- The VFDs shall be specifically designed for **constant torque operation**; but shall also incorporate a choice of output waveforms designed to control quadratic loads to give the VFD flexibility over a wide application area.
- The tenderer shall state the kVA output power of the VFDs in both constant and quadratic torque loads.
- In constant torque mode the VFDs shall be capable of supplying a starting torques of up to 150%-160% of the motors rated torque.
- The VFDs shall be of the type utilizing advanced digital PWM technology.
- Preference shall be given to systems where the output waveform is sinusoidal at all frequencies, such that the motor power is fully utilized at the motors rated speed, and no motor de-rating is necessary.
- Suppliers will have to show a test of the motor's temperature rise with operation, where the motor is operated at full load and speed, shall be seen to be suitable proof. The test shall be based on a class B temperature rise on class F winding insulation.
- If de-rating is applicable the tenderer shall supply curves showing the necessary de-rating of the motor, using class B temperature rise, should be given at rated speed and load to ensure that no overheating occurs.
- The VFDs shall automatically correct the output voltage during main's variations of +/- 10% to prevent loss of torque and speed variations occurring during motor operation.
- **To prevent over-magnetization of the motor at low speeds and light loads the VFD shall incorporate automatic flux control of the motor.**
- **A single fixed voltage boost that cuts out a predetermined frequency will not be considered as automatic control of the flux.**
- The VFDs shall automatically adjust the output frequency and voltage to maintain a stable motor speed of +/- 0.5% of the motor's rated speed.

- The accuracy shall be maintained over a speed and loading range of 10% to 100% without the use of a closed feedback loop.
- **Where the VSDs are specified to control overhauling loads it shall be fitted with a dynamic brake option.**
- ~~**Only Non-Regenerative VFDs to be considered.**~~
- ~~In this specific Application, the cost in energy lost to heat generated during regenerative operation compared to the savings in energy returned to the Grid when using Full Regenerative Drives is comparatively small and cannot justify the initial capital layout to consider a Full Regenerative solution.~~
- **A separate external braking resistor** shall be supplied rated according to the duty cycle required for this Application, the Tenderer to supply with the tender the Braking power and duty cycle.
- This Braking Resistor <<Elements>> must have a minimum IP2x Degree of Protection Rating.
- The Braking Resistor to be galvanically separate from the <Resistor elements> and be named the <<Terminals Enclosure>> this enclosure section must have a minimum IP54 Degree of Protection Rating.
- The Braking Resistor <<Elements>> cubicle must use natural ventilated by means of natural convection, (No Forced cooling must be considered).
- The Braking Resistor enclosure must be manufactured from 304 Stainless steel.
- The Braking resistors will be installed outside the MCC Room (Drives room) in the vicinity of the MCC to minimize cable lengths, typically the ideal place will be in the vicinity of the <On board Machine HT Transformer>.
- A rain preventive Canopy should be installed over the Braking resistor enclosure.
- The VFDs shall incorporate automatic tuning and setting of the main motor parameters. The tuning shall be based on measurements of the motor's inductance and resistance. The tuning must be done at standstill in order not to affect the application before the VFD is tuned.
- The automatic tuning shall stop and register an alarm condition if the automatic tuning detects an out of balance in the motor windings or cannot set the correct parameters for the motor.

8. **Radio Frequency Interference (RFI):**

- Tenderers are reminded that the plant contains equipment sensitive to RFI interference (such as PLCs and Computers).
- Full compliance to the standards is requested. The VSDs should be well protected and immune to electrical disturbance in order to ensure high reliability
- The VFDs shall comply with the EMC immunity standards:
- **EN 61000-4-2 (IEC 1000-4-2): Electrostatic discharges (ESD)**
Simulation of electrostatic discharge from human beings.
- **EN 61000-4-3 (IEC 1000-4-3): Incoming electromagnetic field radiation, amplitude modulation.**
Simulation of the effects of radar and radio communication equipment as well as mobile communications equipment.
- **EN 61000-4-4 (IEC 1000-4-4) Burst transients.**
Simulation of transients brought about by switching with a contactor, relays or similar devices.
- **EN 61000-4-5 (IEC 1000-4-5) Surge transients.**
Simulation of transients brought about e.g. by lightning that strikes near installations.
- **ENV 50140: Incoming electromagnetic field, pulse modulated.**
Simulation of the impact from GSM telephones.
- **ENV 50141: Cable-borne HF.**
Simulation of the effect of radio transmission equipment connected to supply cables.
- **VDE 0160 class W2 test pulse: Mains transients.**
Simulation of high-energy transients brought about by main fuse breakage, switching of power factor correction capacitors, etc.
- The VFDs shall comply with the EMC emission standards:
- **EN 55011 Class A1: Cable born from (150Khz-30Mhz). Radiated (30Mhz-1Ghz.)**
The VFDs must comply to EN 55011 Class A with 150 m of screened/armoured cable.
- The VFDs shall be fitted with metal enclosures (to form a Faraday Cage) to limit the radiated RFI noise from the VFD.
- The VFDs shall be earthed to the main earth grid with a low impedance connection.

9. RFI Filters

- Where RFI filters are supplied from a separate supply source, documentation showing the test results of the RFI and VFD combination and its compliance to EN55011 shall be supplied as evidence of conformity including the maximum length of cable.
- The separate RFI filters shall be mounted in metal enclosures to the same protection rating as the and located as close to the mains connection terminals of the as possible.
- Ferrite cores mounted on the input cables will not be considered as RFI compliance.

10. Harmonics and Power Factor

- Tenderers are reminded that the plant contains a high portion of harmonic producing loads. The information requested in this section of the specification is important for the evaluation of the total plant's harmonic distortion limits.
- Mains Harmonic currents generated by the VFDs must be limited by external mains reactors OR reactors in the D.C. bus of the VFD. Preference shall be given to VFDs that include reactors in the D.C. bus circuit.
- VSDs that do not include a reactor mounted in the D.C. bus shall be supplied with external three phase reactors connected on the mains side of the VFD. The reactors shall be fitted to each phase and shall have a minimum impedance of 5%. The reactors shall be mounted in steel enclosures to a rating equivalent to the .
- When external three phase reactors are supplied Tenderers shall include the amount of voltage drop that will occur over the reactors at full load and advise how the VSD will respond to the lower voltage.
- When both external input reactors for harmonic reduction and output reactors are fitted the tenderer shall state the amount of expected de-rating which will occur on the motor when running at rated speed and load.
- Tenderers shall include a spectrum of harmonic generating currents in the 1st-25th harmonic range and shall state both the $\cos \phi_1$ and the power factor of the at 100% load.
- Calculation of the power factor must be based on the ratio of the fundamental current, and its displacement from the voltage, to the total RMS current which includes all harmonic currents up to and including the 25th.
- $\cos \phi_1$ will not be accepted as power factor as it only applies to power factor in loads which draw a sinusoidal current.
- In order to eliminate any system resonance occurring within the motor's operating frequency range, the VFDs shall be provided with several bypass frequency adjustments. The bandwidth shall be adjusted as a percentage of the recorded by-pass frequencies.

- High efficiency motors are used therefore the VFDs must have a built-in anti-resonance algorithm in order not to cause resonance in the system.
- The VFDs shall be suitable for the control of high inertia loads and be able to catch a rotating motor under any operating condition without tripping. Whether through large supply interruptions, or by the action of switching on and off the motor isolating switch when the motor is running.
- The function shall also ensure that a motor on a high inertia load already pre-rotating, even in the reverse direction, can be switched onto, braked to zero speed by D.C. injection braking incorporated in the VFD and then accelerated to the preset speed in the correct direction.
- The VFDs shall incorporate a PID regulator to enable closed loop control of the process. The regulator shall operate in conjunction with the ramp adjustments to allow smooth acceleration into regulation. Remote monitoring of the feedback signal via a 0/4 - 20mA signal from the VFD is required.
- To prevent condensation, build up in the stator The VFDs shall incorporate a pre-heat function. When the motor is stopped it shall receive a low D.C. voltage from the .
- **VFDs shall be capable of allowing motor cable runs of up to 300 meters** with an un-screened / unshielded cable and 150m with a screened / shielded cable.
- If the VFDs cannot allow these cable lengths, the tenderer shall state the maximum cable length allowed, and the motor coil reactance value intended to be used to increase the cable length. The tenderer shall state clearly the voltage drop and additional motor de-rating that will occur when motor reactors are fitted.
- **The VFDs shall be suitably protected to allow for switching to take place on the output via, a contactor or isolating switch without damage to the VFD inverter block transistors (IGBTs).**

11. CONTROL AND MONITORING:

- All VFD's analogue and digital control inputs and outputs shall be galvanically isolated from each other and from the mains supply and shall be capable of withstanding a test voltage of 2.5 kV dc for 1 sec. For safety reasons, only that have galvanic isolation as an integral part of the VFD will be accepted.
- The VFDs shall respond to speed commands from 0-10 V dc, 2-10 V dc 1-5 V dc and 0/4-20 mA control signals, and their respective inverted signals.
- **For maximum noise immunity on the digital inputs the sink current shall be minimum 10 mA and 24 V for each input. The internal power supply for the supply to the digital inputs shall have a minimum capacity of 200mA at 24V.**

- The VFDs shall have an alpha-numeric display and shall provide comprehensive information on the VFD regarding the motor condition. The following is considered as minimum requirements:
 - a. Reference % of control signal
 - b. Frequency Hz
 - c. Display of feedback signal
 - d. Current Amps
 - e. Torque %
 - f. Power kW
 - g. Energy kWh
 - h. Output voltage V
 - i. D.C. voltage V
 - j. Motor thermal reserve %
 - k. Inverter thermal reserve %
 - l. Monitoring of the Status of the Digital Inputs & Outputs
 - m. Monitoring of the Status of the Analogue Inputs & Outputs
- The tenderer shall state clearly which displays are available, whether the VFD can display the parameters mentioned above and what alternative methods can be used if the VFD cannot display these parameters.
- One programmable analogue output shall be provided for monitoring. A choice of 0-20 mA and 4-20 mA shall be provided. The programmable options shall include as a minimum Hz, Amps, and Torque.
- A minimum of two programmable relays shall be provided for remote monitoring of the VFD. The programmable options shall include as a minimum VFD Ready, VFD running and VFD Trip alarm. The contacts shall have a minimum rating of 250 V, 2A ac. The VFD run relay function shall initiate a run signal only when the frequency output from the VFD is greater than 0.5 Hz.
- The VFDs shall incorporate the following totalizers.
 - n. Hour run meter
 - o. Kilowatt Hours
- The VFDs shall display all faults in clear English text. The following is considered as minimum requirements.
 - p. Inverter fault
 - q. Over voltage/Under voltage
 - r. Over current
 - s. Ground Fault
 - t. Over Temperature
 - u. Overload
 - v. Motor Trip

- **The VFDs shall incorporate English text, the Faults may not be distinguishable only through a code system.**
- The VFD shall preferably be fitted with a USB serial port and be supplied with suitable software utilizing a windows environment to display all monitoring, fault, alarm and status signals. The software shall allow parameter changes to be made to the VFD's settings by uploading the data from the VFD, changing the parameters, and then downloading the data to the VFD again. Storage of each 's operating, and set-up parameters shall be able to be stored outside the VFD's environment.
- The VFDs must have a facility to <Download> or <Upload> the Parameters from and to the VFD's Keypad / HMI Panel.
- The VFD shall have provision to accept an option card for high speed serial communication. PROFIBUS, PROFINET, Ethernet, Modbus RTU, Modbus TCP/IP, ControlNet or DeviceNet are accepted fieldbus standards.
- The design should be such that an external 24 Volt supply can be connected to maintain operation of the microprocessor and serial communication bus during the loss of AC Mains Voltage.
- The VFDs shall preferably be supplied with safe stop functionality suitable for category 3 installations as defined by **EN 954-1** and **SIL 2/IEC 61508** this feature will prevent a drive from starting accidentally.

12. PROTECTION AND MONITORING

- The VFDs shall shut down safely under the following conditions and operate the alarm relay. The 's display shall indicate the nature of the fault in clear English text.
 - Over voltage
 - Under voltage
 - Over current
 - Earth fault
 - Over Temperature
 - Overload
 - Motor trip
 - Inverter fault
- The VFDs must not be destroyed by a short or an earth fault on the output neither by switching on the output.
- The VFDs shall provide for both automatic and manual reset operation. Automatic reset shall only operate on over current and over and under voltage. In automatic mode there shall be a programmable choice of up to 10 reset attempts per fault before the VFD shuts down making manual reset necessary to restart the system. The restart time after a trip in automatic mode shall be adjustable.

- For safety reasons the VFDs must have a trip lock function preventing an operator resetting the VFD under extreme conditions.
- In manual reset mode the reset shall be accomplished from both the keypad on the VFD and by remote signal.
- The VFDs shall be equipped with a data log menu that will allow storage of the type of faults that have occurred. Last fault memory shall be required in the event of power failures.
- The VFDs shall also incorporate a TRENDING facility allowing for several parameters (at least 5) to be trended in real time.
- The VFDs shall include electronic motor thermal overload protection where the trip time is based on the motors running frequency, actual motor current, operating time and the motors rated current. The device shall automatically modify the trip time to consider operation at low speed. On trip the VFDs shall indicate that the fault is a motor thermal trip.
- The VFDs shall include a motor PTC thermistor input for use when motors are fitted with thermistors and shut down the motor when the PTC resistance value increases above its safe operating value. On trip the VFD shall indicate that the fault is a motor thermal trip.
- The tenderer shall state whether **full repair facilities** are available, and in which local Provinces/Cities they are located.

13. SLEW VFD(s) SIZING:

13.1. 3 x Slew VFDs

- 3 x MCCB Rating= 60A
- Motor kW= 3 x 18.5kW
- **Minimum VFD Rating @ Constant Torque= 30kW @ 400V AC**
- VFDs to have Built-in Braking IGBT facility continuously rated able to dissipate the full VSD Power rating.
- Input Line Semi-conductor protection fuses with Trip indication
- Input Line 3 Phase AC Reactor, or DC Bus DC reactor
- Braking Resistors
- Alphanumerical Keypad display mounted on the Door with extension cable.
- Profibus card
- Control circuitry
- Indication Pilot lights on the door, VFD Healthy, Running and Tripped
- Other requirements as stipulated above in this document.

13.1.1. 3 VFDs Control Philosophy.

- In the event of a 3 VFD system, One VFD will act as the Master and the other two VFDs as Followers (Speed & Torque).

- The system must always then ensure 100% load sharing amongst the 3 VFDs , this includes during acceleration, deceleration and when at speed.
- One VFD will be set to operate in <<Speed close Loop>> via an encoder installed on the motor NDE Shaft
- The other two VFDs will also have encoders fitted, the reason for this is to ensure redundancy in the event of the <<Master>> VFD encoder going faulty, in this case a selector switch will select which VFD will become the New Master and the Others become Followers, this may be done by setting an Input Bit on each of the VFDs via the Profibus communications protocol map.

14. VFD Enclosure(s):

- Mild steel single or double door floor standing enclosure.
- Material: Frame: 1.5 to 2mm painted steel.
- Door: 2mm painted steel.
- Rear, roof and side panels: 1.35mm painted steel.
- Mounting plate: 2.7 to 3mm galvanized steel.
- Bottom plates: 1mm galvanized steel.
- Frame: Seam welded reversed open profiles with 25mm hole pattern according to DIN 43660.
- Including integrated external hole pattern.
- Door: Mounted with four hinges allowing left- or right-hand opening. Including door frame with 25mm hole pattern.
- Rear panel: Fitted by M6 torx screws.
- Standard facilities for rear door mounting.
- Side panels: Supplied as an accessory.
- Roof panel: Removable.
- Lock: Espagnolette 4-point locking system does not interfere with the enclosure inner space.
- Standard double-bit lock with 3mm pin.
- Can be exchanged for standard inserts or Euro-cylinder and swing handle.
- Bottom plates: Consists of three or four pieces.
- Mounting plate: Double folded and slides into position.
- Adjustable in depth by steps of 25mm with the fastening accessory.
- Earthing: All panels are earthed through their fittings and are equipped with a separate earthing stud.
- Finish: RAL 7035 structured powder coating.
- Protection: Corresponds with IP 56, NEMA 4, 12 and 13.

15. VFD Enclosure Air circulation Channels

These channels must be constructed in such way that the heat dissipated by the heatsink is channeled away from the Front of the VFD where the electronics are installed.

16. Documentation:

Documentation required includes:

Manufacturing general arrangement with all relevant dimensions for installation purposes, Maintenance manual; Final commissioning data sheets as installed.

17. Commissioning:

Commissioning of the VFD to be done by expert personnel familiar with the Application

18. Warranty:

Minimum requirements are; 18 months after shipment date or 12 months from date of commissioning whichever comes first.

TECHNICAL SPECIFICATION

[STACKER RECLAIMER 1 - SR1]

TRANSNET PORT TERMINALS

Z.5200 160 BULK TERMINAL SALDANHA

EQUIPMENT RETROFIT:

TRAVEL DRIVE(s) VFDs

Revision 0.0

**Technical Specification
for
AC Speed
For Stacker Reclaimer # 1**

SECTION 1:**1. GENERAL**

- 1.1 Nominal voltage operation
- 1.2 Voltage tolerance
- 1.3 Maximum ambient operation
- 1.4 Ventilation and cooling
- 1.5 Enclosure rating
- 1.6 Enclosure material
- 1.7 Quality assurance standards

1. PERFORMANCE

- 2.1 Load torque requirement
- 2.2 Technology, motor de-rating
- 2.3 Main voltage compensation
- 2.4 Vector control of the output voltage
- 2.5 Speed holding accuracy
- 2.6 Dynamic braking for overhauling load
- 2.7 Auto tuning of motor parameters
- 2.8 Radio Frequency Interference
- 2.9 Harmonics and power factor
- 2.10 System and motor resonance
- 2.11 Mains starts per hour
- 2.12 Motor reactance coils
- 2.13 Flying start on fans
- 2.14 PID regulator
- 2.15 Motor pre-heat
- 2.16 Cable length
- 2.17 Switching on the output

3. CONTROL AND MONITORING

- 3.1 Galvanic isolation
- 3.2 Input control signals
- 3.3 Noise immunity on digital inputs
- 3.4 Display requirements
- 3.5 Analogue outputs
- 3.6 Relay outputs
- 3.7 Totalizers
- 3.8 Fault display

- 3.9 Serial communication
- 3.10 Serial communication - high performance
- 3.11 24 VDC auxiliary power supply
- 3.12 Safe stop

4. PROTECTION AND MONITORING

- 4.1 VFD shut down
- 4.2 Manual and auto reset
- 4.3. Data log of faults
- 4.4. Electronic thermal overload protection
- 4.5. Thermistor protection
- 4.6. Local repair facilities

SECTION 2:

5. INTRODUCTION to VFD requirements

- This specification has been based on the minimum criteria necessary for reliable operation of A.C. variable frequency drives (VFDs) when used in industrial applications.
- **This specification covers only Constant Torque Applications.**
- Whilst it is widely known that the VFDs provide the highest efficiency and yield the greatest energy savings in speed control of process equipment, other potential problems such as radio frequency interference RFI , harmonic disturbance THD, and poor motor performance can easily offset the potential advantages.
- Full compliance with the specifications may easily be overlooked, especially when there are major differences in price between tenderers offering different solutions, and rectification of the problems later may prove to be time consuming and prohibitively costly.
- The majority of VFDs on the market are based on the PWM principle of operation, however their similarity stops here as development of the output voltage waveform, motor protection, motor performance, RFI and THD reduction methods widely separate the units both in terms of performance and cost.
- The main reason for the additional costs is that, many of the functional features to minimize harmonics and RFI, and to improve control and motor protection are hardware devices which are expensive and take up space inside the control cubicle.
- Many users are unaware of the amount of harmonic distortion the VFDs can produce if they are not fitted with the necessary harmonic reactor coils, and the increase of mains current the VFDs consume if these coils are not fitted.

- Harmonic loads have only proliferated in the past decade, mainly due to the large increase in the use of VFDs, but the knowledge required to maintain clean supplies has not kept up with the technology, with the result that many industrial plants suffer major harmonic problems.
Other important issues such as RFI, galvanic isolation and long motor life are also vital in maintaining a <problem free> plant.
- This specification presents an unbiased view of the technical requirements necessary to ensure high performance and reliability with minimum disturbance to the plant's environmental conditions.

SECTION 3:

SPECIFICATION FOR AC SPEED DRIVE,

6. GENERAL

- The VFDs shall be of the type suitable for controlling the speed of 3 phase, 380V-400V induction motors.
- The VFDs shall be capable of operating continuously at nominated full load rating with expected variations of +/- 10% in the supply voltage and +/- 2% in the supply frequency.
- The VFD shall be capable of operating continuous operation at full load in a maximum ambient temperature of **50°C**, with a 24hour average maximum of 45 °C.
Care shall be taken during installation to ensure that the VFDs are protected from direct sunlight and weather elements.
- The VFDs shall have a ventilation solution that provides total separation of the cooling air circulating through the Heatsink and the air circulating through the electronics section of the VFD, in order to reduce risk of contaminants entering the drive, using principles such as **cold plate technology**, or an externally mounted heat sink, or **preferably back channel cooling**.
 - Where the VFDs are separately wall mounted the enclosure protection rating shall comply with the following guidelines:
 - The environment around the Stacker reclaimer 2 MCC room is subject to moisture and harsh environmental conditions.
 - There are presently measures in place to protect the MCC internal electrical environment against such harsh conditions but from time to time it has been proven inadequate or insufficient.
 - **The VFD shall therefore be protected to IP54 and/or IP66 rating.**
 - There shall be no de-rating of the maximum ambient temperature for an IP54 and/or IP66 enclosure.

- The enclosures shall be constructed in mild steel to prevent the radiated radio frequency interference noise (RFI) from affecting the operation of other equipment.
- The metal enclosures must be earthed with a low impedance connection to the main earthing system.
- The VFDs shall be manufactured to quality assurance and manufacturing standards according to ISO 9001.

7. PERFORMANCE

- The VFDs shall be specifically designed for **constant torque operation**; but shall also incorporate a choice of output waveforms designed to control quadratic loads to give the VFD flexibility over a wide application area.
- The tenderer shall state the kVA output power of the VFDs in both constant and quadratic torque loads.
- In constant torque mode the VFDs shall be capable of supplying a starting torques of up to 150%-160% of the motors rated torque.
- The VFDs shall be of the type utilizing advanced digital PWM technology.
- Preference shall be given to systems where the output waveform is sinusoidal at all frequencies, such that the motor power is fully utilized at the motors rated speed, and no motor de-rating is necessary.
- Suppliers will have to show a test of the motor's temperature rise with operation, where the motor is operated at full load and speed, shall be seen to be suitable proof. The test shall be based on a class B temperature rise on class F winding insulation.
- If de-rating is applicable the tenderer shall supply curves showing the necessary de-rating of the motor, using class B temperature rise, should be given at rated speed and load to ensure that no overheating occurs.
- The VFDs shall automatically correct the output voltage during main's variations of +/- 10% to prevent loss of torque and speed variations occurring during motor operation.
- **To prevent over-magnetization of the motor at low speeds and light loads the VFD shall incorporate automatic flux control of the motor.**
- **A single fixed voltage boost that cuts out a predetermined frequency will not be considered as automatic control of the flux.**
- The VFDs shall automatically adjust the output frequency and voltage to maintain a stable motor speed of +/- 0.5% of the motor's rated speed.

- The accuracy shall be maintained over a speed and loading range of 10% to 100% without the use of a closed feedback loop.
- **Where the VSDs are specified to control overhauling loads it shall be fitted with a dynamic brake option.**
- **Only Non-Regenerative VFDs to be considered.**
- In this specific Application, the cost in energy lost to heat generated during regenerative operation compared to the savings in energy returned to the Grid when using Full Regenerative Drives is comparatively small and cannot justify the initial capital layout to consider a Full Regenerative solution.
- **A separate external braking resistor** shall be supplied rated according to the duty cycle required for this Application, the Tenderer to supply with the tender the Braking power and duty cycle.
- This Braking Resistor <<Elements>> must have a minimum IP2x Degree of Protection Rating.
- The Braking Resistor to be galvanically separate from the <Resistor elements> and be named the <<Terminals Enclosure>> this enclosure section must have a minimum IP54 Degree of Protection Rating.
- The Braking Resistor <<Elements>> cubicle must use natural ventilated by means of natural convection, (No Forced cooling must be considered).
- The Braking Resistor enclosure must be manufactured from 304 Stainless steel.
- The Braking resistors will be installed outside the MCC Room (Drives room) in the vicinity of the MCC to minimize cable lengths, typically the ideal place will be in the vicinity of the <On board Machine HT Transformer>.
- A rain preventive Canopy should be installed over the Braking resistor enclosure.
- The VFDs shall incorporate automatic tuning and setting of the main motor parameters. The tuning shall be based on measurements of the motor's inductance and resistance. The tuning must be done at standstill in order not to affect the application before the VFD is tuned.
- The automatic tuning shall stop and register an alarm condition if the automatic tuning detects an out of balance in the motor windings or cannot set the correct parameters for the motor.

8. **Radio Frequency Interference (RFI):**

- Tenderers are reminded that the plant contains equipment sensitive to RFI interference (such as PLCs and Computers).
- Full compliance to the standards is requested. The VSDs should be well protected and immune to electrical disturbance in order to ensure high reliability
- The VFDs shall comply with the EMC immunity standards:
- **EN 61000-4-2 (IEC 1000-4-2): Electrostatic discharges (ESD)**
Simulation of electrostatic discharge from human beings.
- **EN 61000-4-3 (IEC 1000-4-3): Incoming electromagnetic field radiation, amplitude modulation.**
Simulation of the effects of radar and radio communication equipment as well as mobile communications equipment.
- **EN 61000-4-4 (IEC 1000-4-4) Burst transients.**
Simulation of transients brought about by switching with a contactor, relays or similar devices.
- **EN 61000-4-5 (IEC 1000-4-5) Surge transients.**
Simulation of transients brought about e.g. by lightning that strikes near installations.
- **ENV 50140: Incoming electromagnetic field, pulse modulated.**
Simulation of the impact from GSM telephones.
- **ENV 50141: Cable-borne HF.**
Simulation of the effect of radio transmission equipment connected to supply cables.
- **VDE 0160 class W2 test pulse: Mains transients.**
Simulation of high-energy transients brought about by main fuse breakage, switching of power factor correction capacitors, etc.
- The VFDs shall comply with the EMC emission standards:
- **EN 55011 Class A1: Cable born from (150Khz-30Mhz). Radiated (30Mhz-1Ghz.)**
The VFDs must comply to EN 55011 Class A with 150 m of screened/armoured cable.
- The VFDs shall be fitted with metal enclosures (to form a Faraday Cage) to limit the radiated RFI noise from the VFD.
- The VFDs shall be earthed to the main earth grid with a low impedance connection.

9. RFI Filters

- Where RFI filters are supplied from a separate supply source, documentation showing the test results of the RFI and VFD combination and its compliance to EN55011 shall be supplied as evidence of conformity including the maximum length of cable.
- The separate RFI filters shall be mounted in metal enclosures to the same protection rating as the and located as close to the mains connection terminals of the as possible.
- Ferrite cores mounted on the input cables will not be considered as RFI compliance.

10. Harmonics and Power Factor

- Tenderers are reminded that the plant contains a high portion of harmonic producing loads. The information requested in this section of the specification is important for the evaluation of the total plant's harmonic distortion limits.
- Mains Harmonic currents generated by the VFDs must be limited by external mains reactors OR reactors in the D.C. bus of the VFD. Preference shall be given to VFDs that include reactors in the D.C. bus circuit.
- VSDs that do not include a reactor mounted in the D.C. bus shall be supplied with external three phase reactors connected on the mains side of the VFD. The reactors shall be fitted to each phase and shall have a minimum impedance of 5%. The reactors shall be mounted in steel enclosures to a rating equivalent to the .
- When external three phase reactors are supplied Tenderers shall include the amount of voltage drop that will occur over the reactors at full load and advise how the VSD will respond to the lower voltage.
- When both external input reactors for harmonic reduction and output reactors are fitted the tenderer shall state the amount of expected de-rating which will occur on the motor when running at rated speed and load.
- Tenderers shall include a spectrum of harmonic generating currents in the 1st-25th harmonic range and shall state both the $\cos \phi_1$ and the power factor of the at 100% load.
- Calculation of the power factor must be based on the ratio of the fundamental current, and its displacement from the voltage, to the total RMS current which includes all harmonic currents up to and including the 25th.
- $\cos \phi_1$ will not be accepted as power factor as it only applies to power factor in loads which draw a sinusoidal current.
- In order to eliminate any system resonance occurring within the motor's operating frequency range, the VFDs shall be provided with several bypass frequency adjustments. The bandwidth shall be adjusted as a percentage of the recorded by-pass frequencies.

- High efficiency motors are used therefore the VFDs must have a built-in anti-resonance algorithm in order not to cause resonance in the system.
- The VFDs shall be suitable for the control of high inertia loads and be able to catch a rotating motor under any operating condition without tripping. Whether through large supply interruptions, or by the action of switching on and off the motor isolating switch when the motor is running.
- The function shall also ensure that a motor on a high inertia load already pre-rotating, even in the reverse direction, can be switched onto, braked to zero speed by D.C. injection braking incorporated in the VFD and then accelerated to the preset speed in the correct direction.
- The VFDs shall incorporate a PID regulator to enable closed loop control of the process. The regulator shall operate in conjunction with the ramp adjustments to allow smooth acceleration into regulation. Remote monitoring of the feedback signal via a 0/4 - 20mA signal from the VFD is required.
- To prevent condensation, build up in the stator The VFDs shall incorporate a pre-heat function. When the motor is stopped it shall receive a low D.C. voltage from the .
- **VFDs shall be capable of allowing motor cable runs of up to 300 meters** with an un-screened / unshielded cable and 150m with a screened / shielded cable.
- If the VFDs cannot allow these cable lengths, the tenderer shall state the maximum cable length allowed, and the motor coil reactance value intended to be used to increase the cable length. The tenderer shall state clearly the voltage drop and additional motor de-rating that will occur when motor reactors are fitted.
- **The VFDs shall be suitably protected to allow for switching to take place on the output via, a contactor or isolating switch without damage to the VFD inverter block transistors (IGBTs).**

11. CONTROL AND MONITORING:

- All VFD's analogue and digital control inputs and outputs shall be galvanically isolated from each other and from the mains supply and shall be capable of withstanding a test voltage of 2.5 kV dc for 1 sec. For safety reasons, only that have galvanic isolation as an integral part of the VFD will be accepted.
- The VFDs shall respond to speed commands from 0-10 V dc, 2-10 V dc 1-5 V dc and 0/4-20 mA control signals, and their respective inverted signals.
- **For maximum noise immunity on the digital inputs the sink current shall be minimum 10 mA and 24 V for each input. The internal power supply for the supply to the digital inputs shall have a minimum capacity of 200mA at 24V.**

- The VFDs shall have an alpha-numeric display and shall provide comprehensive information on the VFD regarding the motor condition. The following is considered as minimum requirements:
 - a. Reference % of control signal
 - b. Frequency Hz
 - c. Display of feedback signal
 - d. Current Amps
 - e. Torque %
 - f. Power kW
 - g. Energy kWh
 - h. Output voltage V
 - i. D.C. voltage V
 - j. Motor thermal reserve %
 - k. Inverter thermal reserve %
 - l. Monitoring of the Status of the Digital Inputs & Outputs
 - m. Monitoring of the Status of the Analogue Inputs & Outputs
- The tenderer shall state clearly which displays are available, whether the VFD can display the parameters mentioned above and what alternative methods can be used if the VFD cannot display these parameters.
- One programmable analogue output shall be provided for monitoring. A choice of 0-20 mA and 4-20 mA shall be provided. The programmable options shall include as a minimum Hz, Amps, and Torque.
- A minimum of two programmable relays shall be provided for remote monitoring of the VFD. The programmable options shall include as a minimum VFD Ready, VFD running and VFD Trip alarm. The contacts shall have a minimum rating of 250 V, 2A ac. The VFD run relay function shall initiate a run signal only when the frequency output from the VFD is greater than 0.5 Hz.
- The VFDs shall incorporate the following totalizers.
 - n. Hour run meter
 - o. Kilowatt Hours
- The VFDs shall display all faults in clear English text. The following is considered as minimum requirements.
 - p. Inverter fault
 - q. Over voltage/Under voltage
 - r. Over current
 - s. Ground Fault
 - t. Over Temperature
 - u. Overload
 - v. Motor Trip

- **The VFDs shall incorporate English text, the Faults may not be distinguishable only through a code system.**
- The VFD shall preferably be fitted with a USB serial port and be supplied with suitable software utilizing a windows environment to display all monitoring, fault, alarm and status signals. The software shall allow parameter changes to be made to the VFD's settings by uploading the data from the VFD, changing the parameters, and then downloading the data to the VFD again. Storage of each 's operating, and set-up parameters shall be able to be stored outside the VFD's environment.
- The VFDs must have a facility to <Download> or <Upload> the Parameters from and to the VFD's Keypad / HMI Panel.
- The VFD shall have provision to accept an option card for high speed serial communication. PROFIBUS, PROFINET, Ethernet, Modbus RTU, Modbus TCP/IP, ControlNet or DeviceNet are accepted fieldbus standards.
- The design should be such that an external 24 Volt supply can be connected to maintain operation of the microprocessor and serial communication bus during the loss of AC Mains Voltage.
- The VFDs shall preferably be supplied with safe stop functionality suitable for category 3 installations as defined by **EN 954-1** and **SIL 2/IEC 61508** this feature will prevent a drive from starting accidentally.

12. PROTECTION AND MONITORING

- The VFDs shall shut down safely under the following conditions and operate the alarm relay. The 's display shall indicate the nature of the fault in clear English text.
 - Over voltage
 - Under voltage
 - Over current
 - Earth fault
 - Over Temperature
 - Overload
 - Motor trip
 - Inverter fault
- The VFDs must not be destroyed by a short or an earth fault on the output neither by switching on the output.
- The VFDs shall provide for both automatic and manual reset operation. Automatic reset shall only operate on over current and over and under voltage. In automatic mode there shall be a programmable choice of up to 10 reset attempts per fault before the VFD shuts down making manual reset necessary to restart the system. The restart time after a trip in automatic mode shall be adjustable.

- For safety reasons the VFDs must have a trip lock function preventing an operator resetting the VFD under extreme conditions.
- In manual reset mode the reset shall be accomplished from both the keypad on the VFD and by remote signal.
- The VFDs shall be equipped with a data log menu that will allow storage of the type of faults that have occurred. Last fault memory shall be required in the event of power failures.
- The VFDs shall also incorporate a TRENDING facility allowing for several parameters (at least 5) to be trended in real time.
- The VFDs shall include electronic motor thermal overload protection where the trip time is based on the motors running frequency, actual motor current, operating time and the motors rated current. The device shall automatically modify the trip time to consider operation at low speed. On trip the VFDs shall indicate that the fault is a motor thermal trip.
- The VFDs shall include a motor PTC thermistor input for use when motors are fitted with thermistors and shut down the motor when the PTC resistance value increases above its safe operating value. On trip the VFD shall indicate that the fault is a motor thermal trip.
- The tenderer shall state whether **full repair facilities** are available, and in which local Provinces/Cities they are located.

13. TRAVEL VFD(s) SIZING:

13.1. 2 x single Travel VFD, each suitable to Control 24 x 7,5kW motors in total.

- MCCB Rating= 400A
- Motor kW= 24 x 7,5kW
- **Minimum VFD Rating @ Constant Torque= 200kW @ 400V AC**
- VFD to have Built-in Braking IGBT facility continuously rated able to dissipate the full VSD Power rating.
- Input Line Semi-conductor protection fuses with Trip indication
- Input Line 3 Phase AC Reactor, or DC Bus DC reactor
- Braking Resistor
- Alphanumerical Keypad display mounted on the Door with extension cable.
- Profibus card
- Control circuitry
- Indication Pilot lights on the door, VFD Healthy, Running and Tripped
- Other requirements as stipulated above in this document.

13.1.1. VFDs Control Philosophy:

- Each VFD to drive all 24 motors in Open loop.

- Each Motor Cable Outlet to have a MCCB with Thermal Overload protection but they are **not part of this SCOPE OF WORK**, as they are installed elsewhere in a separate Cubicle inside the MCC.
- 3 x PT100 motor windings temperature monitoring unit linked to the PLC.

14. VFD Enclosure(s):

- Each VFD to be installed in its own separate Mild steel single or double door floor standing enclosure.
- Material: Frame: 1.5 to 2mm painted steel.
- Door: 2mm painted steel.
- Rear, roof and side panels: 1.35mm painted steel.
- Mounting plate: 2.7 to 3mm galvanized steel.
- Bottom plates: 1mm galvanized steel.
- Frame: Seam welded reversed open profiles with 25mm hole pattern according to DIN 43660.
- Including integrated external hole pattern.
- Door: Mounted with four hinges allowing left- or right-hand opening. Including door frame with 25mm hole pattern.
- Rear panel: Fitted by M6 torx screws.
- Standard facilities for rear door mounting.
- Side panels: Supplied as an accessory.
- Roof panel: Removable.
- Lock: Espagnolette 4-point locking system does not interfere with the enclosure inner space.
- Standard double-bit lock with 3mm pin.
- Can be exchanged for standard inserts or Euro-cylinder and swing handle.
- Bottom plates: Consists of three or four pieces.
- Mounting plate: Double folded and slides into position.
- Adjustable in depth by steps of 25mm with the fastening accessory.
- Earthing: All panels are earthed through their fittings and are equipped with a separate earthing stud.
- Finish: RAL 7035 structured powder coating.
- Protection: Corresponds with IP 56, NEMA 4, 12 and 13.

15. VFD Enclosure Air circulation Channels

These channels must be constructed in such way that the heat dissipated by the heatsink is channeled away from the Front of the VFD where the electronics are installed.

16. Documentation:

Documentation required includes:

Manufacturing general arrangement with all relevant dimensions for installation purposes, Maintenance manual; Final commissioning data sheets as installed.

17. Commissioning:

Commissioning of the VFD to be done by expert personnel familiar with the Application

18. Warranty:

Minimum requirements are; 18 months after shipment date or 12 months from date of commissioning whichever comes first.

SR3 Lubrication System Scope:

Tripper Car Grease System:



Replace all the following items:

Pump Elements, Metering Devices, Flexible hoses, pressure gauges, relieve valves and grease pump with 30kg stainless steel reservoir.

Inspect the following items and replace if required:

Fittings, stainless steel tubing, hose clips.

Service complete system and commission control system.

Slew Bearing Grease System (Outside):



Replace all the following items:

Pump Elements, Metering Devices, Flexible hoses, pressure gauges, relieve valves and grease pump with 10kg stainless steel reservoir, grease brushes.

Inspect the following items and replace if required:

Fittings, stainless steel tubing, hose clips.

Service complete system and commission control system.

Bucket Wheel Grease System:



Replace all the following items:

Pump elements, Metering Devices, Flexible hoses, pressure gauges, and relieve valves. Install new grease pump with 10kg stainless steel reservoir at operator cabin and install new electrical junction box for power supply.

Inspect the following items and replace if required:

Fittings, stainless steel tubing, hose clips.

Service complete system and commission control system.

Slew Bearing Grease System (Inside):



Replace all the following items:

Install Progressive System, Pump elements, Metering Devices, Flexible hoses, pressure gauges, and relieve valves. Install new grease pump with 10kg stainless steel reservoir.

Inspect the following items and replace if required:

Fittings, stainless steel tubing, hose clips.

Service complete system and commission control system.

Travel Bogie and Pivot Points Grease System:



Replace all the following items:

Pump Elements, Metering Devices, Flexible hoses, pressure gauges, and relieve valves. Install new grease pump with 30kg stainless steel reservoir.

Inspect the following items and replace if required:

Fittings, stainless steel tubing, hose clips.

Service complete system and commission control system.



BULK TERMINAL SALDANHA STACKER-RECLAIMER CABIN REPLACEMENT

Operations Requirements

Date: 12 September 2018

Contents

PROJECT CHARTER: Make Stacker/ Reclaimer (1-3) Cabins Ergonomically Friendly For OBHE	3
STACKER RECLAIMER 1,2 & 3 REVAMP SOW Operator's wish list	5
Possible solutions:.....	7
1. Anthropometry: body sizes, shapes, populations and variations.....	7
2. Environmental physics: noise, light, heat, cold radiation, vibration body systems, hearing, vision and sensations.....	8
3. Biomechanics: muscles, levers, forces and strength.....	10
Recommended solutions:	11

PROJECT CHARTER:

Make Stacker/ Reclaimer (1-3) Cabins Ergonomically Friendly For OBHE

<p>BACKGROUND AND REASON FOR SELECTING THE PROJECT:</p> <p>Ergonomics is the process of designing or arranging workplace, products and systems so that they fit the people who use them. So as technologies changes, so too does the need to ensure that tools we access for work and rest are designed for our body's requirements.</p> <p>Currently the Cabins of SR1, 2&3 are not ergonomically friendly. The chairs and the pedals are not ergonomically designed, the interior layout is not designed to accommodate 2 to 3 people at once and this makes it difficult to move around or even store your goods inside the cabin, without having to block the walkways.</p>	<p>PROJECT OBJECTIVE</p> <p>To make the cabins of SR 1,2 and 3 durable and ergonomically friendly for the operator</p>
<p>OPPORTUNITY STATEMENT:</p> <p>The bulk terminal stockyard area is equipped with four (4) stacker/Reclaimer and out of these Stacker/Reclaimer only one (1) is semi-automated and it has a bigger cabin which has sufficient space, and the other three (3) are manually operated with a smaller cabin which has limited space.</p> <p>Therefore with the SR refurbishment there's an opportunity to upgrade the cabin of SR (1, 2&3) to be similar to S4. This will reduce bad ergonomics.</p>	<p>PROJECT SCOPE:</p> <p>This project will focus on the following: Exterior: Cabin windows, wipers, door and door handle. Interior: Cabin floor , foot rest, foot pedal, chair and overall layout This project will only cover SR 1, 2&3 cabins. It will exclude all other cabins</p>

ACTIVITY	DUE DATE
DEFINE	18/05/2018
MEASURE	01/06/2018
ANALYSE	15/06/2018
IMPROVE	06/07/2018
CONTROL	

TEAM SELECTION:

Veronica Nengovhela – Project Manager
Ettiene Albertus– Sponsor
Ebrahim Jacobs– Process owner
Hedley Engelbrecht - Subject matter process expert
Siphelele Bolitshi – Subject matter process expert
Enro Pick – Subject matter process expert
Ndumiso Ngobese- Subject matter process expert
Nomagcino Ngcobo – Subject matter process expert
Peter Boois – Subject matter process expert
Luntu Seleka – Subject matter process expert
Graham Handley- TPT Project

STACKER RECLAIMER 1, 2 & 3 REVAMP SOW Operator's wish list

Item	Challenges	Suggestions
<ul style="list-style-type: none"> • Rubber floor (i.e. Warm floor)_4.1.1.9 	<p>When having to clean it will be difficult, water and dust can come in-between the floor and the rubber.</p>	<p>Rubberizing the floor to avoid the water and dust sliding underneath the floor making it easier to clean.</p>
<ul style="list-style-type: none"> • Place to store (bags, coffee materials & cleaning detergence) _4.1.1.2 	<p>Bags are all on the floor and this is not a safety act because one can trip on the bag.</p>	<p>3 Hookers in the cabin that the bags can be hooked on. And a folder table when one wants to eat.</p>
<ul style="list-style-type: none"> • Socket/plugs to be closer to the operator's chair 	<p>The radio is far and it's a problem when one wants to charge cell phone or change a channel.</p>	<p>More sockets and the radio be opposite operator. Computer box higher or wires go outside on top of the roof and a small box.</p>
<ul style="list-style-type: none"> • Strong window glasses (bullet proof) • Strong door (Bullet proof glass door)& door handles_4.1.1.14 	<p>Window difficult to clean, easily brake and when operating at night operator must go out cabin and see if his reclaiming right. Wind can blow windows crack and doors get damaged.</p>	<p>Sliding door, flipping window and laminated window.</p> <p>Refer to ship loader 2</p>

<ul style="list-style-type: none"> • Mini bar fridge 	Food gets spoilt before shift end.	TFR locomotives
<ul style="list-style-type: none"> • Bigger cabin_4.1.1.2 	The space is not enough for the operator to sort their belongings, and also to accommodate the assistance's chair	
<ul style="list-style-type: none"> • Roof air conditioner 4.1.1.22 		
<ul style="list-style-type: none"> • Footrest 		Refer to the attached documents
<ul style="list-style-type: none"> • Adjustable and big SCADA 	The SCADA is too small and difficult for shorter operators to view it	
<ul style="list-style-type: none"> • Basin 		The basin should be placed on the outside like the one at SR4
<ul style="list-style-type: none"> • Increase the walkways outside the cabin 	It is difficult to wipe the windows when the wipers are not functioning	
<ul style="list-style-type: none"> • Modify the electrical box(make it smaller) 		Refer to ship loader 1 cabin The wires can be engraved on the roof top/ on the side walls
<ul style="list-style-type: none"> • Sun blockers(blinders) 		Refer to the attached documents
<ul style="list-style-type: none"> • Comfortable chair(i.e. backrest) and warm chairs for (OBHE & OBLA) _4.1.1.1 		Refer to the attached notes

Possible solutions:

1. **Anthropometry:** body sizes, shapes, populations and variations
 - Ergo seat s

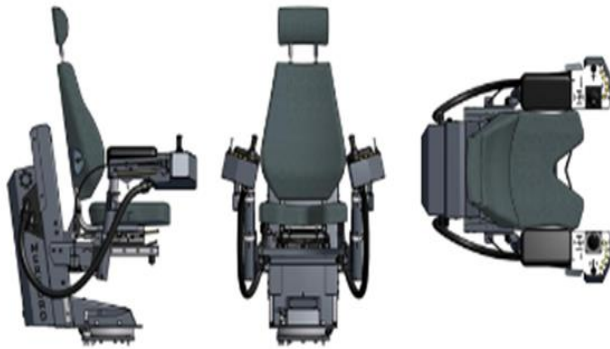

Trunk Posture



Flexion/Extension
Mild is 20° to 45°
Severe is > 45°



Bending
Bent is > 20°



Twisting
Twist is > 20°

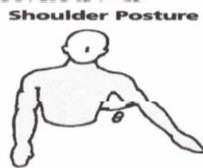

Flexion/Abduction
Mild is 45° to 90°
Severe is > 90°

Neck Posture



Flexion/Extension
Mild is 30° to 45°
Severe is > 45°



Bending
Bent is > 20°



Twisting
Twist is > 20°

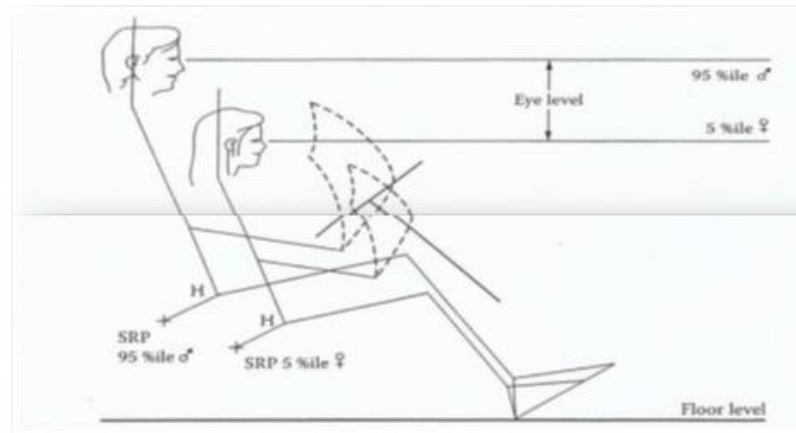

The chair accommodates:

- The 5th to the 95th percentile of personnel
- The chair have adjustment capabilities that can accommodate a range of statures, postures and behaviours
- The operating postures, the tasks that need to be performed, the clothes and required protective
- The chair is able to adjust vertical, forward, backwards, recline and weight adjustments.

2. Environmental physics: noise, light, heat, cold radiation, vibration body systems, hearing, vision and sensations

a. Tinted glass-is a glass with colour added

- It helps keep the heat out during the summer months but keeps it in during the winter, thus reducing the costs of air conditioning and heating.

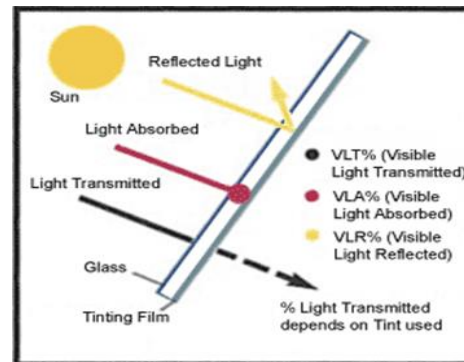

Window Tint Film

1. Carbon window tint film

i) advantages

- doesn't have any metal in it, so the issue with cell phones and radio transmission doesn't arise when it is used
- is dark and matte-finished, so it provides a tasteful option on windows
- blocks about 40% of the infrared light (the kind that causes warmth) that enters through the windows
- is about as effective as other varieties in blocking heat; its use will effectively cool inside space while also helping prevent fading to upholstery
- Thus the air conditioning will not need to work so hard to cool the space during the summer, nor will the heating system be so heavily impacted during the winter
- Unlike dyed film, carbon film will not fade with time.

2. Ceramic window tint film

i) Advantages

- is the highest quality of window tint film, and also the most expensive
- contains neither metal, dye, nor carbon, but instead a kind of ceramic particle that is both nonconductive and nonmetallic
- cuts from 45% to 50% of the solar heat that enters through the windows in the form of infrared light, while allowing maximum visibility both by day and night
- allows maximum efficiency in the functioning of radios, cell phones, GPS systems, and all other such devices being operated from inside the protected space
- is also most effective in its blocking of ultraviolet light from the interior; in the case of ultraviolet light (the kind of light rays that contribute to sunburn and skin cancer)
- Block up to 99% from entering the interior.



3. **Biomechanics:** muscles, levers, forces and strength

Dead man switch (pedal)-Is a standard safety feature on the Stacker/Reclaimer

By design:

The operator needs to keep the dead man's pedal down when operating the machine.

But:

You can stand on the dead man's pedal to apply it; no force is required to push it down. However the operator will often shift their weight onto the foot holding down the pedal without even realising it.

The course of a long shift, this can cause strain in the leg and foot, which slows things down. Also causes discomfort and even injury to the operator

Operator's solution

- Operators can potentially place an object onto the pedal or even tie down to override it



Recommended solutions:

a. **Vigilance Control System - Dead Man's Switch**



Vigilance Control System (VCS) can also be referred to as Dead Man's Switch or Driver Safety Device (DSD).

- The Vigilance Control System (VCS) increases train safety by checking the train driver vigilance at all times. When the driver experiences a loss of consciousness, death or any physical issues preventing him to react, the train is automatically stopped.

Key Features

- In practice, the train driver notifies his vigilance by pressing onto a pedal or a dedicated momentary push button, thus sending a signal to the Vigilance Control System (VCS). The VCS can also monitor other actions, based on your needs.
- In case the VCS stop receiving signals, alarms are activated according to a predefined schedule. The first alarm is a blinking light (T1). Should the driver fail to respond within the allowed time frame, a bell ring will be heard (T2). Finally, if still no action is detected from the driver, the VCS will automatically send command for train emergency braking to ensure passengers' safety (T3). Automatic braking is also triggered if the VCS is powered off.

b. **Driver Safety System (DSS) :**

- Camera-based system that monitors features on the driver's or operator's face. The system can determine if the driver has closed his eyes for more than a mere blink or if his gaze has become distracted, and it will provide an **alarm** or a **seat vibration** to warn and wake the driver.



c. CAT Smart band Data:

- It uses the principle of pulse oximetry to detect heart-rate.

Pulse oximetry -is a technique that tells us if person is getting enough oxygen or not

The operation of Pulse oximetry is based on measuring of the absorption of red and Infra-Red light that passes through the wrist. The reflected light rays received at photodetector looked as a waveform. During heart-beat blood volume increases and this AC component of the photodetector is used to calculate the heart-rate. Thus if heart-rate indicates the drowsiness then alarm will be raised to alert the driver. For the alert systems, we have beeper device.

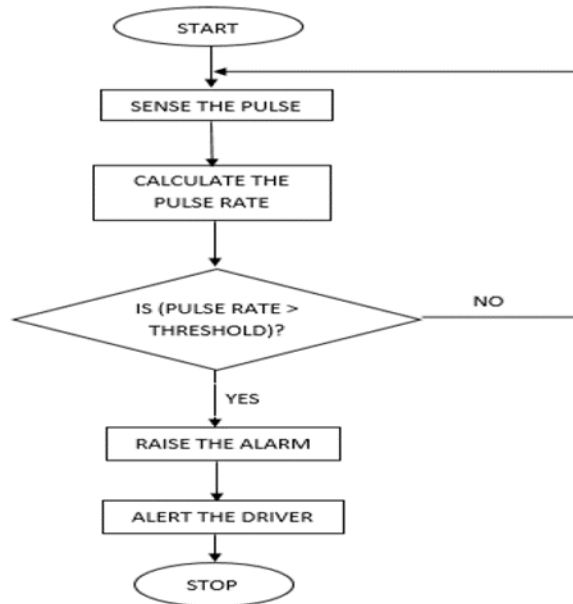

TECHNICAL SPECIFICATION

[STACKER RECLAIMER 1 - SR1]

TRANSNET PORT TERMINALS

Z.5200 160 BULK TERMINAL SALDANHA

EQUIPMENT RETROFIT:

OPERATOR'S CABIN EQUIPMENT & CHAIR REPLACEMENT

Revision 0.0

1. Operator's Cabin:

The Existing Operator's Cabin is to be replaced by a New one made of 304 Stainless steel, to be dealt with under the structural portion.

Note: The New Cabin will have at least 10 to 20% larger foot print.

1.1. The New Operator's cabin will comprise of the following components.

- New SCADA monitoring Station, sufficiently large to enable the Operator to visualize all the information clearly from his chair, complete with an Industrial type mouse mounted on the RHS console, similar to the existing one.
- New Operator's Chair including all the Cabin Controls.
- New Marshalling Cabinet including all necessary Power supplies, UPS and Optical Fibre converters.
- New Cabin Intelligent Levelling Monitoring Unit.

1.2. New Cabin D.B. for:

- 1.2.1. 4 x 15Amp industrial type 3 pin switched Plugs,
- 1.2.2. 1 x Cabin lights circuit,
- 1.2.3. 1 x Air conditioner unit circuit,
- 1.2.4. 1 x Cabin Pressurization air filter Fan
- 1.2.5. 1 x Stockpile Scanners Power supply
- 1.2.6. 1 x 220/24V DC Cabin window Wipers circuit with Control switch mounted on the RHS console, rated for the 3 Wiper motors and Water reservoir pump, motors and pump driven by interposing relays rated accordingly.
- 1.2.7. 1 x SCADA Monitor unit Power supply
- 1.2.8. 1 x Cabin Controls UPS
- 1.2.9. 2 x 220/24V DC Power supplies (Redundancy mode), to supply all the Cabin 24 V Dc circuits, such as PLC remote I/O slaves, Optical Converters, Scanners
- 1.2.10. 1 x Cabin walkway external lights circuit with Daylight switch and Daylight switch override.
- 1.2.11. All light fittings to be <Low energy consumption> type,
- 1.2.12. All external light fittings IP67.
- 1.2.13. At least 20% of the Lights installed inside and outside the Operator's cabin to be of the <<emergency lighting battery backed up type>>.

2. Cabin Operator's Chair:

2.1. The aim here is to create an ergonomic environment suitable to the operation of a Stacker reclaimer.

This prevents physical stress and reduces absence due to illness.

The Chair supplied must provide the Operator with a wide range of adjustment options to ensure all operators may adjust it to their ergonomic needs, the adjustments must be motorized.

Good ergonomic sitting posture for a wide range of male and female body dimensions must be available on this Chair.

The Chair is to be positioned in the Cabin in a position that allows a clear view of the Operator of the surroundings of the machine and its operation.

It must be easy for the Operator to use the forearms as support and to operate the consoles with his/her hands.

The load placed on the neck and back decreases significantly as a result of this feature, which enables the operator to be and continue to be efficient. The entire design of the Chair contributes to improved visibility from the operator cabin. Combined with the operator's ergonomic sitting position, an efficient and safe machine operation is within reach.

2.2. Typical overview of the Operator's chair required:

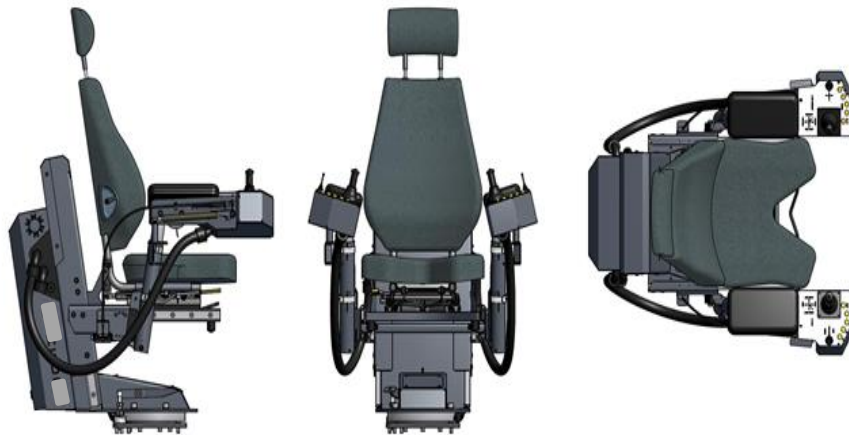

2.3. Chair minimum specifications:

- 2.3.1. Fabric upholstery color black, leather upholstery, seat cover upholstered in Heavy duty leather type.
- 2.3.2.
- 2.3.3. Motorized adjustments:
 - Fwd-Bwd
 - Height
 - Backrest
 - Lumbar support & Inclination
 - Tilt adjustment
 - Weight/suspension adjustment pneumatic-electric
- 2.3.4. Other:
 - Head rest & armrests, heavy duty V-cut in cushion
 - Safety belt Height adjustment may be not necessary
 - Heating integrated in seat: cushion + backrest, not required
 - Console width adjustment Console forward - backward
 - Console up - down adjustment
 - Console revolving & Console tilt adjustable
 - Pre-drilled top-plates
 - Consoles with width and length heavy duty material engraved text plates,
 - Console completely wired to terminals to a Back panel.
 - Steel parts RAL 7015, dark grey
 - User, maintenance and parts manual
 - Swiveling panels RH side and LH side
 - Control components, Master-controllers, pushbuttons and switches,
 - IEC or UL/CSA Certification.

3. Cabin Operator's controls required:

Operator's cabin Controls					
Item	Function	Digital	Analogue	Type	Comments
1	Travel Left	1		NO contact	Combined Joystick controller
2	Travel Right	1		NO contact	
3	Travel Left speed demand		x	Linear 0-10V with 3 way Isolation converter	
3	Travel Right speed demand		x	Linear 0-10V with 3 way Isolation converter	
4	Luff Raise	1		NO contact	
5	Luff Lower	1		NO contact	
6	Luff Raise speed demand		x	Linear 0-10V with 3 way Isolation converter	
6	Luff Lower speed demand		x	Linear 0-10V with 3 way Isolation converter	
7	Combined Joystick <In Neutral position>	1		NC contact	
8	Combined Joystick <Dead mans handle>	1		NO contact	
9	Slew Clockwise	1		NO contact	Single Joystick controller
10	Slew Anti-Clockwise	1		NO contact	
11	Slew Clockwise speed demand		x	Linear 0-10V with 3 way Isolation converter	
11	Slew Anti-Clockwise speed demand		x	Linear 0-10V with 3 way Isolation converter	
12	Joystick <In Neutral position>	1		NC contact	
13	Joystick <Dead mans handle>	1		NO contact	
14	Left Console Emergency stop	2		NC contact	E. Stop Push button
15	Right Console Emergency stop	2		NC contact	E. Stop Push button
16	Control Reset	1		NO contact	Push button
17	Horn Foot pedal	1		NO contact	Foot Pedal
18	Audible alarm			Field Horn	200m field range
19	Windows Wippers switch	2			On - Off Switch
20	Daylight Override switch				On - Off Switch
21	SCADA monitor Industrial type mouse				Heavy duty mouse pad, mounted onto the RHS console
22	Cabin levelling monitoring system enclosure. with the following indication lights: POWER ON (green) SAFE (Green) WARNING (Yellow) DANGER (Danger)				An intelligent Cabin levelling monitoring indication system is to be installed in this enclosure to warn the Operator about the Cabin levelling status

4. Cabin industrial Climate Unit:

An Industrial Climate Unit improves the climate of an operator cabin in an efficient way.

Achieves a pleasant temperature in each climate and be guaranteed with good vision thanks to the demisting function.

The temperature inside cabins should provide reasonable comfort.

A pleasant temperature inside the cabin improves the wellbeing and performance of the operator and the efficiency of the machine.

An industrial Climate Unit must provide heating, cooling, ventilation and a demisting function.

Control the indoor temperature of the cabin, even in climates with an outside temperature up to 50°C. The climate unit is developed for use in industrial conditions.

As a result, it can stand harsh influences.

Temperature control is very important as it has been proven that people perform at their best under temperatures ranging between 23°C to 24°C.

Good temperature control is a must, especially in this extreme climate.

The primary use of this unit is to regulate cabin temperature, humidity and airflow, ensuring that these elements remain within their acceptable ranges.

A fully integrated climate control unit, consisting of air-conditioning, heating and fresh air supply.

The system is automatically temperature-controlled and equipped with a high-performance demisting function.

5. Other Electric equipment required:

Other electrical Operator's in the cabin					
Item	Description	Input Volt.	Output Volt.	Rating	Comments
1	SCADA Monitoring Unit	UPS-220V AC	OEM defined	NA	Large Screen
2	Industrail Console Mouse	OEM defined	OEM defined	NA	A reliable rugged and easy to integrate mouse module that is the ideal cursor control solution for industrial vision inspection systems. The mouse module must be easily sealed into the console to create an interface impervious to water and dust. Must provide standard data outputs that allow easy interfacing with the SCADA monitoring unit. With no moving parts to break or wear out Must be completely maintenance-free and designed to last through more than 10 million actuations, even in the harshest conditions.
3	Marshaling Cabinet	As required	As required	NA	Installed on the Left rear corner of the Cabin
4	Optical Fibre converters	As required	As required	NA	Copper/Fibre & Fibre / Copper
5	UPS	220V AC	220V AC	As required to feed the Cabin Controls	Back up battery time, @ least 10 to 20 minutes
6	Cabin D.B.	220V AC	220V AC	As required	See 1.2. above
7	Window wipers LHS window pan	24V DC	24V DC	As required	Large water reservoir with electric pump
8	Window wipers RHS window pan	24V DC	24V DC	As required	
9	Window wipers Front window pan	24V DC	24V DC	As required	
10	Window wipers Dedicated Power supply	220V AC	12/24V DC	OEM defined	
11	Industrial Cabin Climate Control Unit	220V AC	OEM defined	Rated for the Cabin Volume	
12	Control Power supplies UPS backed-up	220V AC	24V DC		Redundancy mode design
13	Stock pile scanners Power supply	220V AC	24V DC		
14	Stock pile scanners 24V DC Plug 1	24V DC			
15	Stock pile scanners 24V DC Plug 2				
16	PTT Cabin Radio compatible with Plant Standard				
17	Remote I/O rack	24V DC	NA		With at least 15% additional Digital Input and Output elements.
18					
19					
20					

6. Documentation required includes:

Manufacturing general arrangement with all relevant dimensions for installation purposes, Maintenance manual; Final commissioning data sheets as installed.

7. Commissioning:

Commissioning of the Cabin Operator's System integrated with the Machine Control PLC and SCADA system.

8. Communications Protocol:

Between the Remote I/O stations and the Main PLC <<Profibus DP>> is the preferred communications Protocol, with Optical fibre converter links where required to comply with EMC conditions.

9. Warranty:

Minimum requirements are; 18 months after shipment date or 12 months from date of commissioning whichever comes first.

TECHNICAL SPECIFICATION

[STACKER RECLAIMER 1 - SR1]

TRANSNET PORT TERMINALS
Z.5200 160 BULK TERMINAL SALDANHA
EQUIPMENT RETROFIT:
TOW BAR FESTOON SYSTEM

Revision 0.

1. Tow Bar Festoon:

Comprising of all the cables and other pipes connecting the Tripper car to the Stacker reclaimer.

- 1.1. Remove the existing Tow Bar Festoon system, this includes the removal of:
- 1.2. Carrier beam and supports.
- 1.3. All existing cable carriers.
- 1.4. Towing arm.
- 1.5. Junction boxes.
- 1.6. Relevant accessories.
- 1.7. Supply and Installation of a new system comprising of:
 - 1.7.1. New 304 Stainless steel Junction boxes, complete with suitable terminals, allowing for different voltages compartmental separation.
This includes safe separation between medium voltage cables, low voltage cables and control cables.
 - 1.7.2. New Supports and Supporting beam made from Stainless steel 304, the beam and supports must be able to handle the hanging load right through the entire Festoon system.
 - 1.7.3. New Canopy over the beam covering the length and width of the Festoon system, to prevent product spillage to build up over the Festoon system.
 - 1.7.4. New Festoon cables must be H07 RNF or similar capable to handle the surrounding environment and possible contamination by grease and other chemicals.
 - 1.7.5. Cable lengths to be measured and confirmed by the Tenderers during the site visit.
Cables to be fastened across the cable tiers at every loop, bundling them in groups with appropriate cable supports to ensure they won't tangle or jump over each other during operation.
 - 1.7.6. New cables to be terminated with suitable crimping lugs into terminals according to their respective operating Voltages and cable sizes.
Where required cable shielding connections to be installed according to best practice EMC Directives, (i.e. Ground and shielding).
 - 1.7.7. Special consideration to be taken, ensuring EMC compliances are respected between Power carrying cables and Control signal cables.
 - 1.7.8. Cross section of Power cables to follow the minimum requirements of SANS taking into consideration the lengths and subsequent Volt drop.
 - 1.7.9. Any cable should not have any significant Volt drop that may affect the performance of any of the equipment, (i.e. Motors and other Power loads).
 - 1.7.10. Control cables minimum cross-sectional size to be 2.5mm² along the Festoon cable system, to improve mechanical strength of the same.
- 1.8. The existing FIXED cables at both ends of the Festoon system (where applicable), will remain the same, when installing the Junction boxes this needs to be taken into consideration, no variations allowed for replacing FIXED cables that due to the installation of the new junction boxes may require replacement, in the event this is required it will be for the successful bidder account, unless proven to

the Client the replacement was somewhat necessary, the Client will have the final say on this matter.

2. List of cables:

Cable #	FROM - LOCATION	FROM - ITEM	TO - LOCATION	TO - ITEM	mm 2	CORES (NOTE 5) (NOTE 8)	VOLT	CABLE TYPE (NOTES 6 & 9)	CIRCUIT TYPE
111-A	TOWED STRUC FESTOON	JUNCTION BOX: TSJB5	TOWED STRUCTURE FESTOON	JUNCTION BOX: TSJB6	185	1C	3300	TRAILING MEDIUM VOLTAGE	POWER
111-B	TOWED STRUC FESTOON	JUNCTION BOX: TSJB5	TOWED STRUCTURE FESTOON	JUNCTION BOX: TSJB6	185	1C	3300	TRAILING MEDIUM VOLTAGE	POWER
111-C	TOWED STRUC FESTOON	JUNCTION BOX: TSJB5	TOWED STRUCTURE FESTOON	JUNCTION BOX: TSJB6	185	1C	3300	TRAILING MEDIUM VOLTAGE	POWER
112	TOWED STRUC FESTOON	JUNCTION BOX: TSJB3	TOWED STRUCTURE FESTOON	JUNCTION BOX: TSJB4	2,5	4C	110	TRAILING H07/TR75	CONTROL
113-A	TOWED STRUC FESTOON	JUNCTION BOX: TSJB3	TOWED STRUCTURE FESTOON	JUNCTION BOX: TSJB4	N/A	2F	N/A	FIBRE OPTIC - SEE NOTE 7	SIGNAL
113-B	TOWED STRUC FESTOON	JUNCTION BOX: TSJB3	TOWED STRUCTURE FESTOON	JUNCTION BOX: TSJB4	N/A	2F	N/A	FIBRE OPTIC - SEE NOTE 7	SIGNAL
113-C	TOWED STRUC FESTOON	JUNCTION BOX: TSJB3	TOWED STRUCTURE FESTOON	JUNCTION BOX: TSJB4	N/A	2F	N/A	FIBRE OPTIC - SEE NOTE 7	SIGNAL
114	TOWED STRUC FESTOON	JUNCTION BOX: TSJB3	TOWED STRUCTURE FESTOON	JUNCTION BOX: TSJB4	N/A	2F	N/A	FIBRE OPTIC - SEE NOTE 7	SIGNAL
115	TOWED STRUC FESTOON	JUNCTION BOX: TSJB3	TOWED STRUCTURE FESTOON	JUNCTION BOX: TSJB4	N/A	2F	N/A	FIBRE OPTIC - SEE NOTE 7	SIGNAL
116	TOWED STRUC FESTOON	JUNCTION BOX: TSJB3	TOWED STRUCTURE FESTOON	JUNCTION BOX: TSJB4	N/A	2F	N/A	FIBRE OPTIC - SEE NOTE 7	SIGNAL
117	TOWED STRUC FESTOON	JUNCTION BOX: TSJB3	TOWED STRUCTURE FESTOON	JUNCTION BOX: TSJB4	N/A	MF	N/A	FIBRE OPTIC - SEE NOTE 7	SIGNAL
118	TOWED STRUC FESTOON	JUNCTION BOX: TSJB3	TOWED STRUCTURE FESTOON	JUNCTION BOX: TSJB4	N/A	MF	N/A	FIBRE OPTIC - SEE NOTE 7	SIGNAL
613	TOWED STRUC FESTOON	JUNCTION BOX: TSJB1	TOWED STRUCTURE FESTOON	JUNCTION BOX: TSJB2	25	3C+E	3300	TRAILING H07/TR75	POWER
614	TOWED STRUC FESTOON	JUNCTION BOX: TSJB1	TOWED STRUCTURE FESTOON	JUNCTION BOX: TSJB2	25	3C+E	3300	TRAILING H07/TR75	POWER
615	TOWED STRUC FESTOON	JUNCTION BOX: TSJB3	TOWED STRUCTURE FESTOON	JUNCTION BOX: TSJB4	2,5	4C	400	TRAILING H07/TR75	POWER
616	TOWED STRUC FESTOON	JUNCTION BOX: TSJB3	TOWED STRUCTURE FESTOON	JUNCTION BOX: TSJB4	2,5	4C	400	TRAILING H07/TR75	POWER
617	TOWED STRUC FESTOON	JUNCTION BOX: TSJB3	TOWED STRUCTURE FESTOON	JUNCTION BOX: TSJB4	2,5	4C	400	TRAILING H07/TR75	POWER
618	TOWED STRUC FESTOON	JUNCTION BOX: TSJB3	TOWED STRUCTURE FESTOON	JUNCTION BOX: TSJB4	2,5	4C	400	TRAILING H07/TR75	POWER
619	TOWED STRUC FESTOON	JUNCTION BOX: TSJB3	TOWED STRUCTURE FESTOON	JUNCTION BOX: TSJB4	2,5	4C	400	TRAILING H07/TR75	POWER
620	TOWED STRUC FESTOON	JUNCTION BOX: TSJB3	TOWED STRUCTURE FESTOON	JUNCTION BOX: TSJB4	2,5	4C	400	TRAILING H07/TR75	POWER
621	TOWED STRUC FESTOON	JUNCTION BOX: TSJB3	TOWED STRUCTURE FESTOON	JUNCTION BOX: TSJB4	2,5	4C	400	TRAILING H07/TR75	POWER
622	TOWED STRUC FESTOON	JUNCTION BOX: TSJB3	TOWED STRUCTURE FESTOON	JUNCTION BOX: TSJB4	10	4C	400	TRAILING H07/TR75	POWER
623	TOWED STRUC FESTOON	JUNCTION BOX: TSJB3	TOWED STRUCTURE FESTOON	JUNCTION BOX: TSJB4	2,5	3C	400	TRAILING H07/TR75	POWER
624	TOWED STRUC FESTOON	JUNCTION BOX: TSJB3	TOWED STRUCTURE FESTOON	JUNCTION BOX: TSJB4	2,5	3C	110	TRAILING H07/TR75	POWER
625	TOWED STRUC FESTOON	JUNCTION BOX: TSJB3	TOWED STRUCTURE FESTOON	JUNCTION BOX: TSJB4	4	3C	220	TRAILING H07/TR75	POWER
626A	TOWED STRUC FESTOON	GANTRY STRUCTURE EARTH	TOWED STRUCTURE FESTOON	TOWED STRUCTURE EARTH	120	1C	E	WELDING	POWER
626B	TOWED STRUC FESTOON	GANTRY STRUCTURE EARTH	TOWED STRUCTURE FESTOON	TOWED STRUCTURE EARTH	120	1C	E	WELDING	POWER
651	TOWED STRUC FESTOON	JUNCTION BOX: TSJB4	TOWED STRUCTURE FESTOON	JUNCTION BOX: TSJB3	1,5	3C	N/A	TRAILING H07/TR75	SIGNAL
654	TOWED STRUC FESTOON	JUNCTION BOX: TSJB4	TOWED STRUCTURE FESTOON	JUNCTION BOX: TSJB3	1,5	3C	N/A	TRAILING H07/TR75	SIGNAL
657	TOWED STRUC FESTOON	JUNCTION BOX: TSJB4	TOWED STRUC FESTOON	JUNCTION BOX: TSJB3	0,8	12 PR	N/A	TRAILING H07/TR75	SIGNAL
659	GANTRY ELECT HOUSE	MV SWITCHGEAR PANEL	TOWED STRUCTURE FESTOON	JUNCTION BOX: TSJB4	1,5	3 TRIAD	N/A	TRAILING H07/TR75	SIGNAL
660	TOWED STRUC FESTOON	JUNCTION BOX: TSJB3	INCLINE CONVEYOR	SUPPRESSION SYSTEM	2,5	3C	N/A	TRAILING H07/TR75	SIGNAL
672	MACHINE UNDER CARRIAGE	JUNCTION BOX: TSJB4	MACHINE UNDER CARRIAGE	JUNCTION BOX: TSJB3(FESTOON)	2,5	3C	220	TRAILING H07/TR75	
673	MACHINE UNDER CARRIAGE	JUNCTION BOX: TSJB4	MACHINE UNDER CARRIAGE	JUNCTION BOX: TSJB3(FESTOON)	2,5	3C	220	TRAILING H07/TR75	
704	TOWED STRUC FESTOON	JUNCTION BOX: TSJB3	TOWED STRUCTURE FESTOON	JUNCTION BOX: TSJB4	1,5	12C	110	TRAILING H07/TR75	CONTROL
705	TOWED STRUC FESTOON	JUNCTION BOX: TSJB3	TOWED STRUCTURE FESTOON	JUNCTION BOX: TSJB4	2,5	4C	110	TRAILING H07/TR75	CONTROL
706	TOWED STRUC FESTOON	JUNCTION BOX: TSJB3	TOWED STRUCTURE FESTOON	JUNCTION BOX: TSJB4	2,5	3C	110	TRAILING H07/TR75	POWER
707	TOWED STRUC FESTOON	JUNCTION BOX: TSJB3	TOWED STRUCTURE FESTOON	JUNCTION BOX: TSJB4	2,5	3C	110	TRAILING H07/TR75	POWER
804	TOWED STRUC FESTOON	JUNCTION BOX: TSJB3	TOWED STRUCTURE FESTOON	JUNCTION BOX: TSJB4	2,5	19C	110	TRAILING H07/TR75	CONTROL
805	TOWED STRUC FESTOON	JUNCTION BOX: TSJB3	TOWED STRUCTURE FESTOON	JUNCTION BOX: TSJB4	2,5	3C	110	TRAILING H07/TR75	POWER
806	TOWED STRUC FESTOON	JUNCTION BOX: TSJB3	TOWED STRUCTURE FESTOON	JUNCTION BOX: TSJB4	2,5	3C	220	TRAILING H07/TR75	POWER
807	TOWED STRUC FESTOON	JUNCTION BOX: TSJB3	TOWED STRUCTURE FESTOON	JUNCTION BOX: TSJB4	2,5	3C	220	TRAILING H07/TR75	POWER
905	TOWED STRUC FESTOON	JUNCTION BOX: TSJB3	TOWED STRUCTURE FESTOON	JUNCTION BOX: TSJB4	2,5	8C	220	TRAILING H07/TR75	CONTROL
906	TOWED STRUC FESTOON	JUNCTION BOX: TSJB3	TOWED STRUCTURE FESTOON	JUNCTION BOX: TSJB4	2,5	4C	400	TRAILING H07/TR75	POWER
907	TOWED STRUC FESTOON	JUNCTION BOX: TSJB3	TOWED STRUCTURE FESTOON	JUNCTION BOX: TSJB4	2,5	4C	400	TRAILING H07/TR75	POWER
908	TOWED STRUC FESTOON	JUNCTION BOX: TSJB3	TOWED STRUCTURE FESTOON	JUNCTION BOX: TSJB4	2,5	3C	220	TRAILING H07/TR75	POWER
909	TOWED STRUC FESTOON	JUNCTION BOX: TSJB3	TOWED STRUCTURE FESTOON	JUNCTION BOX: TSJB4	2,5	3C	220	TRAILING H07/TR75	POWER
1934	TOWED STRUC FESTOON	JUNCTION BOX: TSJB3	TOWED STRUCTURE FESTOON	JUNCTION BOX: TSJB4	6	4C	400	TRAILING H07/TR75	POWER
1935	TOWED STRUC FESTOON	JUNCTION BOX: TSJB3	TOWED STRUCTURE FESTOON	JUNCTION BOX: TSJB4	10	4C	400	TRAILING H07/TR75	POWER
1936	TOWED STRUC FESTOON	JUNCTION BOX: TSJB3	TOWED STRUCTURE FESTOON	JUNCTION BOX: TSJB4	10	4C	400	TRAILING H07/TR75	POWER
1937	TOWED STRUC FESTOON	JUNCTION BOX: TSJB3	TOWED STRUCTURE FESTOON	JUNCTION BOX: TSJB4	6	3C	220	TRAILING H07/TR75	POWER
1938	TOWED STRUC FESTOON	JUNCTION BOX: TSJB3	TOWED STRUCTURE FESTOON	JUNCTION BOX: TSJB4	6	3C	220	TRAILING H07/TR75	POWER
2204	TOWED STRUC FESTOON	JUNCTION BOX: TSJB3	TOWED STRUCTURE FESTOON	JUNCTION BOX: TSJB4	25	3C+E	400		POWER

Note 2:

Cable lengths are to be measured by the Tenderers during the site visit

Including the end tails required to connect to the Junction boxes

3. Documentation:

3.1. Documentation required includes:

Manufacturing general arrangement with all relevant dimensions for installation purposes, Maintenance manual; Final commissioning data sheets as installed.

4. Commissioning:

Commissioning of the Tow Bar Festoon System must be provided.

5. Warranty:

Minimum requirements are; 18 months after shipment date or 12 months from date of commissioning whichever comes first.



Detailed Scope – Stacker Reclaimer 1 SUPPLY CABLE REEL

SCOPE OF WORK:

The SOW comprises of the following Item(s).

Replacement of the Main Power cable reel detailed below.

1. Motorized Mono Spiral Main Power Supply Cable Reel:

The Main Power Cable reel system consists of the following main parts:

1.1. Description:

1 off Motorized Mono spiral Cable reeling drum fitted with VSD motor assembly.

1.2. Overall dimensions of cable compartment:

OD = 6000mm;

ID = 2000mm;

Internal Width = 77mm.

1.3. Other cable reel data:

- Approximate cable reel mass =8000kg
- Payout = 275m plus a minimum of 2 turns permanently wound around the cable reel for strain relief.
- Total amount of cable to be supplied 320m
- Centre feed
- Cable specification = PROTOLON or similar **3 x 185+1x95E+1x(18G50/125μ)+ 1x(2x(2x2.5)C+18) OFE**
- Cable diameter = 76mm
- Mass = 11.25kg/m
- Travelling speed = 30m/min
- Acceleration = 0.102m/sec²
- Mounting height of cable reel= 5012mm from the ground
- Mounting height of the Cable funnel = 1750mm of the ground
- Sliprings = 3+E+5c+12 OFE
- Current ratings:
Phase Sliprings: 3 x 3300V 600A
Earth Slipring: 600A
Pilot sliprings: 5 x 1000V 100A
- Slipring Housing Protection: IP65 painted according to Portnet specification HE9/2/8
- Working Voltage = 3300V
- Slipring enclosure = Made of 304 Stainless steel, IP56
- 2 x Motors supply = 400V AC Dual Motor driving method = VSD with software suitable for cable reel applications, instead of Magnetic clutch.

1.4. Anti-condensation Heater: 80Watts

1.5. Driving motor with VSD control built into a S/S 304 IP65 Enclosure, encoder, anti-condensation heater, electromagnetic disc brake with micro-switch for brake proofing, forced ventilation, Braking resistor.

1.6. Cable reel Rotary cam switch.

2. Cable Feed in funnel:

The Cable funnel should be provided with cable tight shock absorbing facilities on both sides and be suitable to operate with the cable described above. Cable clearance from the ground to the first roller is approximately 550mm Cable funnel Internal width approximately 250mm.

2.1. Cable funnel protections and signals:

- 2.1.1. Tight cable both ends
- 2.1.2. Slack Cable
- 2.1.3. Cable Travelling to the left of center feed
- 2.1.4. Cable Travelling to the right of center feed

3. Documentation:

3.1. Documentation required includes:

Manufacturing general arrangement with all relevant dimensions for installation purposes, Maintenance manual; Final commissioning datasheets as installed.

4. ANNEXES (Existing System)

- Powermite documentation PL017 Sec1
- Powermite documentation PL017 Sec2
- Powermite documentation PL017 Sec3

POWERMITE AFRICA (PTY) LIMITED

METSO MINERALS REF.	: CA 10310
METSO MINERALS PROJECT NAME	: SALDANHA BAY IRON ORE TERMINAL STACKER/RECLAIMERS
METSO MINERALS ORDER NO.	: PO 034149

POWERMITE REF.: COM NO. 1348

INSTALLATION, OPERATION & MAINTENANCE

INSTRUCTION MANUAL

FOR POWERMITE CABLE REELING DRUMS

CRD TYPE: PSM2060-FDA168/167/112/2 – HT 600 – HMK 20/2/112M4

CABLE TYPE : POWERMITE RHEYFIRM (RTS) TRAILING CABLE, 3,3KV

3 X 185 + 1 X 95 + 2(2 X 2,5)C + 18 OFE G50/125

AUTOMATIC WINDING OPERATION

This 15 page Manual is the intellectual property of Powermite and no part of this publication may be reproduced or utilised in any form or by any means without the written permission of the publisher.

Original : 18th December, 2002

Amendment No 1 : 30th June, 2003

POWERMITE AFRICA (PTY) LIMITED**INSTALLATION, OPERATION AND MAINTENANCE INSTRUCTIONS****COM NO. 1348**

This cable reeling drum Manual consists of the following instructions, drawings and literature:-

	<u>PAGE</u>
Item 1	Use of cable reeling drum – (CRD) 3
Item 2	Base Frame and reel 7
Item 3	Drive motor 7
Item 4	Gearbox 7
Item 5	Permanent magnet clutch 7
Item 6	Slipring housing 8
Item 7	Limit Switches / Safety Devices 9
Item 8	Cable overtension device (fitted to Feed-in funnel) 9
Item 9	Slack cable device (fitted to Feed-in funnel) 10
Item 10	Trailing cable Installation Instructions 11
Item 11	Commissioning, see separate instruction RG00.T.015 12
Item 12	CRD Maintenance Instructions 12
Item 13	Fault Finding Hints 14
Item 14	Recommended Spares List 15
Item 15	Information Literature 15

Please Note: For the assembly guidance on Powermite Cable Reeling Drums please refer to "Assembly Instructions Manual for Monospiral Cable Reeling Drum – Power cable/COM 1348"

**POWERMITE AFRICA (PTY) LIMITED
INSTALLATION, OPERATION & MAINTENANCE INSTRUCTIONS**

COM NO. 1348

1. USE OF CABLE REELING DRUM

The cable reeling drum/cable represents the electrical link between the power supply (from a fixed point) and the moving machine.

1.1 OPERATION:

The Cable Reeling Drum (CRD) is designed for 100% E.D. duty cycle and is driven by tandem drive – 400V electric motors, 3 phase, 50 Hz squirrel cage type via their permanent magnetic clutches and a gearbox arrangement.

1.1.1 General Electrical Concept For A Crd:

Please Note: All our electrical components i.e. motors, limit switches etc, are not connected to a central electric panel as part of our CRD design or supply. All our components have to be electrically integrated into the mobile machinery manufacturer's electric wiring diagram/electric panels. If the CRD drive motors are energised Long Travel dependant, a timer must keep the CRD powered to cater for Machines overrun (timing approx. plus 15 seconds). The same applies when the Long Travel drive circuit is switched on i.e. the CRD must be energised approx. 10 seconds before the Long Travel motor is energised and can drive. If the CRD is energised from the Main Isolator/Main contactor and remains energised for as long as the machine is switched on, the same logic applies i.e. a timer must keep the CRD on or off, as the case may be, in a time lag design. Please check your circuitry for correctness of logic.

1.1.2 Automatic Operation:

The mobile machinery can move forward or reverse on a designated pathway and the cable reel will automatically reel the cable on or off the CRD, provided certain criteria are observed.

On drive "A" the motor turns in one direction only, irrespective of whether the cable is being reeled on or off. The motor on drive "B" can turn in both directions in the de-energised condition. However, if the additional torque of drive "B" is required it will turn in the same direction as Drive "A". The motors via their permanent magnet clutches and the gear reduction unit, drive the drum (see Item 1.1.4.2.3) which reels the trailing cable on in a monospiral configuration.

When reeling off the trailing cable, the gear – clutch – reduction unit assembly of drive "A" always acts as a hold back arrangement, ensuring that the cable catenary is kept at the correct tension at all times (refer to Item 1.1.4.2).

**POWERMITE AFRICA (PTY) LIMITED
INSTALLATION, OPERATION & MAINTENANCE INSTRUCTIONS**

COM NO. 1348

1.1.3 General Coments For Operation Under 1.1.2:

The CRD operation is restricted by limit switches (must be electrically integrated into machinery circuitry by others) which will make the mobile machinery stop when

- a). Cable is fully paid out (i.e. to the last 2 layers, see Item 7.1.1a)
- b). Cable is fully reeled onto the CRD (i.e. last layer 150mm below O.D. of reel see Item 7.1.1.b)
- c). There is too much tension on the cable, which can result in cable damage. (see Item 7.2)
- d). There is not enough tension on the cable (slack cable) which may result in loops forming and the cable be run over by the crane or snag against protruding objects among other problems while the Reel remains energised by overlapping timers. (see Item 7.3)

1.1.4 Motorised Reeling Drums - Monospiral With A Dual Motor Drive

This explanation outlines the motorised permanent magnetic drive principal/function of a dual motor CRD drive.

1.1.4.1. The Concept

The motorised Cable Reeling Drum will be driven by two identical, independently fed, electrical squirrel cage motors. Each motor will drive its own permanent magnetic clutch (Type HMK 20 - one with and the other without a fitted "one way bearing"). The gearbox output of the permanent-magnet clutches will be coupled to a splitter-gearbox, which will form the structure of a tandem drive. The output drive of the splitter-gearbox, will be coupled to the shaft mounted gearbox, which will finally drive the cable reel. The CRD requires different torques for a) the payout mode b) the reel-in mode while travelling along the longitudinal travel. As the torque requirement increases, the 2nd motor will come in to assist, or be switched off as requirements reduce. This will be controlled by the gear cam limit switch as described under Item 7.1 and set during commissioning.

**POWERMITE AFRICA (PTY) LIMITED
INSTALLATION, OPERATION & MAINTENANCE INSTRUCTIONS**

COM NO. 1348

**1.1.4.2. PRINCIPAL OF OPERATION FOR THE CRD DRIVES AS
PER ITEM 1.1.4.1 ABOVE IF ENERGISED VIA MAIN
ISOLATOR/MAIN CONTACTOR – NOT LONG TRAVEL DEPENDANT.**

1.1.4.2.1 The two similar drives will be referred to as Drive “A” and Drive “B” and are started or switched off as per Item 1.1.1 Main Isolator/Main Contactor dependant.

1.1.4.2.2 The method of electrical switching the tandem drive i.e. signal received when long travelling, is as follows:-

Step 1: The CRD drive motor “A” unit must be energised, prior to any Machine start up, to ensure readiness for payout/reel in cable operation i.e. pretensioning of the flexible trailing cable. To ensure this procedure, a Long Travel motion time delay, set for approx. 10 seconds, will have to be provided in the circuitry by the machine manufacturer.

Step 2: Machine is now ready to fully operate including the Long Travel motion. Drive “A” is now energised with Step 1, and drive “B” will come in or out, as the requirement may be, via contacts in the gear cam limit switch (see Item 7.1), to assist with additional torque.

Note: It is sometimes desirable to switch off the drives, when no travelling occurs over longer periods, to avoid possible overheating, under very high a.T.conditions (45° and above). To give effect to this feature, a timer should be provided in the electrical panel of the machine manufacturer, which will switch off the CRD drives after - (let’s say 20 minutes - of no-long travelling) a predetermined period. To restart the CRD Step 1 must be strictly observed. (Also refer to Item 1.1.1)

POWERMITE AFRICA (PTY) LIMITED
INSTALLATION, OPERATION & MAINTENANCE INSTRUCTIONS
COM NO. 1348

1.1.4.2.3 Principal Operation of Drive "B" travelling along its path from Position A to B and return to A as depicted on our Drawing No. RG00.T.011.

From A to D	De-energised – free wheeling
From D to C	Energised – supplying additional torque to CRD
From C to E	Energised – supply additional reverse torque to CRD
From E to B	De-energised – free wheeling
From B to E	De-energised – free wheeling
From E to C	Energised – supply additional torque to CRD
From C to D	Energised – supply additional reverse torque to CRD
From D to A	De-energised – free wheeling

For Points A, B, C, D and E refer to Drawing RG00.T.011 Rev 0
(See item 15.1.14).

1.1.4.3 General - Drive Description

Drive "A" and Drive "B" are identical, with the exception of the one-way-bearing being removed from the permanent magnet clutch of Drive "B" and a holding brake* is fitted to the motor of this Drive.
** (See Technical Info Sheet – Brake under Item 15.1.7 of this Manual)

Drive "A" Is fitted with a permanent magnet clutch having a "one way bearing", allowing the motor to turn in the predetermined direction only. When the motor is de-energised, the permanent magnet clutch would act as a slipping brake mechanism, if the CRD turns in the opposite of the predetermined motor direction.

Drive "B" The motor will be fitted with an Electromagnetic Disc Brake with an integrated monitoring micro switch, fitted to the rear of the motor. The brake release operation is dependant on the energisation of the Drive "A" motor. When Drive "A" is operational the Electromagnetic Disc Brake on Drive "B" will be energised and the brake will disengage, alternatively, if Drive "A" is non-operational, then the spring force of the Electro Magnetic Disc brake will be applied (Fail Safe) and the brake will be holding Drive "B". For this reason the permanent magnet clutch (in Drive "B") is without a one way bearing as this device has been removed from the standard design, motorside.

The micro switch can provide an "open brake" or "closed brake" signal (as chosen by machine manufacturer) to the machine operator, who must ensure, that the brake releases, as designed, to facilitate proper cable winding at all times. ** (see Item 1.1.4.3 and Brake Operating Instruction Pages 1 and 5 of 7)

**POWERMITE AFRICA (PTY) LIMITED
INSTALLATION, OPERATION & MAINTENANCE INSTRUCTIONS**

COM NO. 1348

2. BASEFRAME AND REEL:

- 2.1 The baseframe is provided with pre-drilled holes and must be bolted in a pre-arranged position on the machine ensuring that the centre line of shaft is horizontal and at right angle to direction of Travel. This is essential to ensure correct cable winding.
- 2.2 The main bearings, which carry the CRD shaft, are bolted to the base frame and are of the plumber-block self aligning type.
- 2.3 The cable reeling drum consists of two spoked flanges, between which is a rolled shell, dimensioned to suit the cable diameter plus approx. 10% of the diameter of the cable.

The trailing cable is wound up between these flanges as instructed in the attached Cable Installation Instruction Sheet CA00.T.001 REV. 3, which must be strictly observed, and is threaded via the hollow shaft into the slipping housing. Approximately two dead coils of the cable must remain on the drum at all times. (see exploded view Drg. **RG00.D.010 REV 01**)

3. DRIVE MOTORS:

- 3.1 The drive 'A' - electric motor is of the 400V, 3 phase, 50 Hz, IP65 squirrel cage type.
- 3.2 The drive 'B' - electric motor is of the 400V, 3 phase, 50 Hz, IP65 squirrel cage type, fitted with a holding brake monitored by a microswitch (see Items 1.1.4.3 and 15.1.7).

4. GEARBOX:

The gearbox is of the type FDA 168 "helical bevel".

5. PERMANENT MAGNET CLUTCH:

In electric motor driven cable reeling drums the permanent magnet clutches take up the necessary slip and ensures that they do not transport excessive torque from the motors to the trailing cable to overstress the same.

During operation the drive motors and the primary side of the clutches always maintain the same speed and direction (directly coupled).

The clutches with their slip function are designed for continuous rotation of the drive motors and a person could pull the cable off the Reel against the motor rotation if a force is applied larger than the setting of the clutches.

Torque rating depends on the setting of the air gap. (See attached torque adjustment instruction REF. RG03.T.001 Rev. 0 - 2 pages under Item 15.1.6)

Please Note: These clutches heat up during normal operating conditions. They must not be painted which could lead to overheating due to reduced heat dissipation.

POWERMITE AFRICA (PTY) LIMITED
INSTALLATION, OPERATION & MAINTENANCE INSTRUCTIONS
COM NO. 1348

6. SLIPRING HOUSING

- 6.1 The sliprings / rotary optic fibre connector serve to transmit electric currents/data from a rotating supply to a stationary user.

Both high Tension (HT) and Low Tension (LT) sliprings are mounted onto the extended CRD shaft which also drives the rotary optic fibre connector at the end. The cable is guided through the hollow shaft into the slipring housing containing a) HT-rings b) LT-rings c) the optic fibre connector and d) the rotary gear cam limit switch. (see Information sheets under Items 15.1.8 to 11)

The slipring unit consists of the housing which is divided into a number of different compartments containing the slipring assemblies and brush gear, as well as the rotary optical fibre connector, the rotary gear cam limit switch and the anticondensation heater. This heater has to be connected to a power supply of 220V single phase, by Others. The cable entry is provided in the high tension compartment.

- 6.2 The housing is fitted to the gearbox and contains the supports for the brush gear. Brush holders of suitable amperage to match the physical slipring size are provided on each slipring. The sliprings and optic fibre connector are fitted to the extended drum hollow shaft and are connected to the trailing cable of the cable reeling drum. Thus the moving cable of the reel is conveying power and control via the sliprings, to the brush holders. The optical fibre element of the cable will connect via ST connectors to the optic fibre connector. The fixed cable installation will feed into the respective electric panel of the mobile machinery coming from the brush holders of the slipring unit and from the other end of the optic fibre connector.

Access to the slipring unit is from the sides of the protective housing.

Care must be taken when wiring up, that sufficient access space remains available between the slipring, brush gear and the housing, for maintenance and repair work.

- 6.3 The HT slipring assembly is designed for an operating voltage of 3300V on the basis of its creepage - path, clearance values and its dielectric. If fault levels have to be considered the slipring assembly design should match the trailing cable capability. The L.T. sliprings have a voltage capability of 1000V.

The distance bushes between the sliprings comprise of "KITE" material.

Number of sliprings

3 - power	600A	3,3 KV
1 - earth	600A	
4 - control	200A	230V
1 - earth	200A	
12 - OFE 50/125 microns in the rotary optical fibre connection		

- 6.4 **Please Note:** The rotary optical fibre connector is disengaged from the hollow CRD shaft and must only be mechanically linked up when cable reeling drum cable has been finally installed and electrically connected. Care must be taken that the rotary connector can deliver the permissible revolutions. (See literature under Item 15.1.8)

**POWERMITE AFRICA (PTY) LIMITED
INSTALLATION, OPERATION & MAINTENANCE INSTRUCTIONS**

COM NO. 1348

7. LIMIT SWITCHES/SAFETY DEVICES:

- 7.1 A gear cam Limit switch is mounted on the inside of the slipping unit
(see Optic fibre compartment Item 6.1 and Service Instruction under Item 15.1.11)
- 7.1.1 The limit switch has micro switches, which are to stop the mobile machine if initiated as under a) and b)
- a) 2 layers of cable remain on reel (empty reel limit – see Item 1.1.3a)
b) Cable is completely reeled on (full reel limit – see Item 1.1.3b)
- 7.1.2 The same limit switch has contacts to facilitate
- a) bridging of the slack cable Limit Switch (Item 7.3) over the *centerfeed* position
b) the controlling of the drive motor “B” to facilitate torque variance to aid cable winding parameter (see Item 1.1.4.1)
- 7.2 The 2 - overtension Roller limit switches on either side of the Feed-in Funnel are operated by a dancing levers to prevent possible overtension to the cable by stopping the mobile machine should overtension be detected.
For detailed overtension device description see Item 8.
- 7.3 The 2 - slack cable Roller limit switches are operated by a lever fitted within the Feed-in Funnel. In the event of excessive cable slackness, the mobile machinery will have to come to a STOP unless it occurs over the centrefeed position.
Please Note: These Roller limit switches could indicate the direction in which the slack cable occurs, if so programmed by the machine manufacturer.
For detailed slack cable device description see Item 9
To repeat, the CRD/ mobile machinery is switched off i.e. motors are de-energised and permanent magnet clutches at standstill, if respective Limit Switch contact as under Items 7.1.1 a) b), 7.2 and 7.3 are activated.

In such an event authorized and trained personnel must investigate the reason for the Limit Switch action/machine stoppage.

8. CABLE OVERTENSION DEVICE (FITTED TO FEED-IN FUNNEL)

The overtension Roller Switches are fitted to protect against over-stressing and breakage of the expensive cable in the payout or reel-in mode. (see also Item 15.1.9)

The Feed-in funnel, through which the cable is guided onto the cable reeling drum, has Roller switches fitted on both extremities (left and right). Should over tension occur, the cable catenary will tension up, (in an unacceptable worst case scenario, like a ‘bow-string’) thus lifting / activating the respective dancing lever at the bottom of the feed-in funnel, which in turn, activates the Over Tension Roller Limit Switch. This action must stop the respective travel direction of the machine. The machine, however, must still be able to travel in the opposite direction.

**POWERMITE AFRICA (PTY) LIMITED
INSTALLATION, OPERATION & MAINTENANCE INSTRUCTIONS**

COM NO. 1348

9. **SLACK CABLE DEVICE (FITTED TO FEED-IN FUNNEL):**

The slack cable lever is fitted to guard the cable from slacking which might allow the cable to hook against obstructions on the machine or being overrun and cut when resting on the travel rails of the machine, among other possible problems. This action indicates that the drum does not wind correctly.

The device consists of a lever which pivots on a shaft and is fitted with rollers through which the cable is guided. The lever always follows the tension of the cable. The levers' normal position is 30° - 40° out of vertical position on the left or the right side of the Feed-in funnel, as the case may be. Should slack cable arise, the lever will return automatically to the vertical position thus activating the Roller Limit Switches and STOP the mobile machine. These actions indicate that the drum does not wind correctly. (see also Items 13.1.2, 13.1.6 and 15.1.9)

IMPORTANT:

A Limit switch is provided (see Item 7.1.2.a) to sense either side of the centrefeed to indicate that the machine is within the centrefeed space. In this space the slack cable Roller Limit Switches must be bridged out.

The slack cable lever can then move through the vertical position to the other side of the funnel as the machine moves past the centrefeed point (see Item 7.3)

POWERMITE AFRICA (PTY) LIMITED
INSTALLATION, OPERATION & MAINTENANCE INSTRUCTIONS
COM NO. 1348

10. **TRAILING CABLE INSTALLATION INSTRUCTIONS:**
(see Items 15.1.1 and 15.1.2 for literature).

The drive to the CRD is strictly uni-directional.

- 10.1 When electrically connecting the CRD drive motors, the reel must be given a functional test to ensure correct rotation to match the rotation ability of the one way permanent magnetic clutch bearing in drive "A" (wrong direction should activate the overload relay in mobile machinery circuit). Release of brake in drive "B" (non release of brake should activate the overload relay in mobile machine circuit)

10.1.1 Now fit the CRD adjustment clamps to the spokes which are not bolted i.e. the alternate spokes (underneath reel I.D. ring [15]) 11 times to facilitate an easier CRD-spoke adjustment together with the provided adjustment bolts of the spokes. Once the cable is fitted to the reel the clamps remain on CRD.

- 10.2 Placing the cable onto the Reel in accordance with the Flexible Cable Installation Instruction CA00 T.001 REV. 3 and in line with exploded view **DRG. RG00 D.010 REV.01** adhering to the following procedure:

10.2.1 To establish the length of cable to be stripped it is necessary to remove the side cover of the slipping body housing. The distance from the cable gland (reel hollow shaft entry) to the end connection point on the optic fibre connector is measured.

10.2.2 Strip the cable, shorten the individual conductors where necessary - as a function of the distance between the rings - and fix suitable cable lugs to the ends of the copper and ST connectors to the fibres of the optic fibre connector.

10.2.3 Adjust the break-off rubber seal in the cable gland to suit the actual outside diameter of the cable.

10.2.4. Proceeding with the stripped cable end, pull the cable between the Reel halves (10/17) and through the cable clamp (18), previously loosened, onto the reel-spacer-ring (15). Then thread the cable out through the opening of the spokes (22)

10.2.5 Tighten the cable gland and check again that the non-stripped part of the cable is also inside the cable gland. Rubber seal must seal well around the cable.

10.2.6 Please ensure that the cable minimum bending diameter for fixed installations is correct between the cable gland and the entrance to the Reel spacer ring (15) i.e. min. 15 x diameter of cable.

Revision to Drawing No. RG00 D.010 Rev. 01
Addition of item 10.1.1

**POWERMITE AFRICA (PTY) LIMITED
INSTALLATION, OPERATION & MAINTENANCE INSTRUCTIONS**

COM NO. 1348

- 10.2.7 The connecting of the trailing cable to the slipping assembly (see Item 6) must be done strictly in accordance with the relevant specification and local regulations. This also applies to the fixed cable installation for copper and fibres to be connected to the brush gear / optical fibre connector.

Please Note: Cores, which are not covered with a dielectric must be firmly secured to avoid undue Roller to other conductive parts.

- 10.2.8 Roll on 1 of the 2 windings of cable by hand and tighten the clamp (18) provided for the first winding, then roll on the 2nd winding onto the Reel. Now set the "empty reel limit" in the gear cam limit switch – see Item 7.1.1a. Then, further reel up the total required length of cable from the transport drum at the same time manually feeding the cable towards the Reel, strictly in accordance with instructions as per Item 2.3.
- 10.3 Once the cable is completely wound onto the CRD in the unstressed manner, thread the cable tail through the Feed-in funnel and slack cable lever and wind 2 turns around the drum of the centrefeed. Once the trailing cable has been installed to the centrefeed the "full reel limit" has to be set – see Item 7.1.1.b. The cable must not fill the Reel higher than 150mm below the O.D. of the Reel to ensure good guidance at all operational times.

11. **COMMISSIONING:**

To be done by Powermite Personnel (for Instructions see Item 15.1.13).

12. **CABLE REELING DRUM MAINTENANCE INSTRUCTIONS:**

Cable Reeling Drums in general require a minimum of maintenance but stringently applied.

12.1 **Drive:**

Keep motors, and unpainted permanent magnet clutches clean. Check every 3 months or sooner if environment requires same.

12.2 **Main Shaft Bearings:**

Check every 3 months.

Recommended grease : BP Energrease LSE P2 or similar.

**POWERMITE AFRICA (PTY) LIMITED
INSTALLATION, OPERATION & MAINTENANCE INSTRUCTIONS**

COM NO. 1348

12.3 Slipping and Brushgear:

Reliable operation of the slipping unit calls for regular maintenance.

Maintenance intervals should be selected as a function of the operating conditions, however, they should be checked every 3 months. Shorter intervals between services are necessary in the tropics, in very moist atmospheres, with pronounced temperature fluctuations as well as where there are large amounts of aggressive dusts and dirt.

During the maintenance work all deposits are to be cleaned off the slipping body equipment. Moisture and dust must be removed from the surface of the insulators. The insulators must be checked for damage. The surface quality of the slipping on which the brushes run must be good and electrically clean. Beads or scorch points must be removed. Oxidation may develop on the slipping contact surface in units that have not been operated to 360 degrees over a long period or which have been out of operation for some time. This oxidation should be removed. After cleaning, the slipping contact surface can be covered with a film of light contact lubricant to protect them against further oxidation. No lubrication, however, is required during constant operations for slippings which are run with carbon or bronze brushes.

The bronze/carbon brushes should be checked for wear and replaced if necessary. When replacement takes place ensure proper embedding of the brush to the slipping. No further maintenance is required apart from an occasional check on whether all connections are tight and that all springs, which are responsible for the pressure of the brush gear to the slipping, have the correct spring tension.

Check functionality of anticondensation heater 4 weekly.

12.3.1 Optic fibre Rotary Connector:

Maintenance free (see Item 15.1.8)

12.4 Limit Switches on CRD and its Mechanical Levers:

Check in 4 to 6 weekly intervals that safety circuits are functional and that mechanical levers/rollers are kept clean.

12.5 Gearbox:

Check monthly for leakage, refill immediately a leak becomes visible and check cause.

Change oil after 10 000 operational hours or after max. 3 years.

Recommended oil : SHELL Omala 220 or similar.

12.6 Feed-in Funnel:

Check every 3 months that rollers, on which the cable guides, are working and that Slack cable lever operates freely.

POWERMITE AFRICA (PTY) LIMITED
INSTALLATION, OPERATION & MAINTENANCE INSTRUCTIONS
COM NO. 1348

13. FAULT FINDING HINTS:

13.1 Electric Drive:

13.1.1 If reel does not turn:

Check cable is not hooked tight.

Check power is available

Check motor wiring

Check motor performance

Check drive "B" brake has disengaged

Check drive "B" brake monitoring micro switch

Check permanent magnetic clutch function

Check if overload relay is intact

Check for mechanical obstructions

Check gear cam limit switch in slipping unit for cam position i.e.

1) Empty reel

2) Full Reel

3) "B" Drive motor control

4) Over center bridging

of slack cable limit switch

Check on FEED-IN FUNNEL cable overtension proximities

Check on FEED-IN FUNNEL slack cable proximities

13.1.2 Drum turns at too low speed:

Check airgap of permanent magnet clutch for correct adjustment

Check voltage supply for correctness

Check for mechanical obstruction

Check if "B" drive brake has disengaged

13.1.3 The Trailing Cable runs off the reel when CRD is switched off:

Permanent magnet clutch air gap too big.

One way bearing on permanent magnet clutch of drive "A" damaged.

Holding brake on Drive "B" not functional

13.1.4 Circuitry problems:

Please consult the electric drawings of mobile machinery supplier and power supply.

13.1.5 Overtension of cable

Check that the overtension Roller limit switches and dancing levers operate freely in both directions.

Permanent Magnet Clutch air gap possibly too small.

If found working again, test activating machine "Stop".

13.1.6 Slack Cable present:

Check that slack cable limit switches and slack cable lever operate freely.

Check if trailing cable is under proper tension (lever must not be vertical outside centrefeed area).

N.B. If machine stands over the centrefeed space and the slack cable protection is bridged, move machine into operational area to test.

POWERMITE AFRICA (PTY) LIMITED
INSTALLATION, OPERATION & MAINTENANCE INSTRUCTIONS
COM NO. 1348

14. **RECOMMENDED SPARES LIST FOR CRD**
TYPE PSM-2060-FDA 168/167/112/2 – HT600-HMK20/2/112 M4-12 OFE
 Is attached to this presentation.
15. **LITERATURE:**
 The Instructions, drawings and literature, which are listed in this presentation, are to be absolutely observed during the process of installation, and when the equipment is operated and maintained.
- 15.1 Literature attached to this presentation are:-
- 15.1.1 Installation instructions for flexible cables,
 Sheet No. CA00.T.001 – REV 3 - 2 pages
- 15.1.2 POWERMITE – Rheyfirm (RTS) (N)TSCGEWTOEUs, 3,3 KV Cable
 Specification Sheet c/w with 3 Test Certificates - 5 pages.
- 15.1.3 Exploded view of Mono Spiral Cable Reel Drg. No. **RG00.D.010-REV 01** - 1 page
- 15.1.4 Assembly Instruction Manual for Monospiral CRD
 including Drg. No. **RG00.D.009 Rev. 01** - 5 pages
- 15.1.5 4 kW motors for Drive ‘A’ and Drive ‘B’ – see Power-CRD drive motor in
 attached info sheets – 5 pages
- 15.1.6 Torque adjustments for HMK 20 perm. magnetic clutch with one way
 bearing - Drive “A” and without one way bearing – Drive “B”.
 Both clutch types are torque adjusted by procedures as outlined in
 Sheet No. RG03.T.001 – REV. 0 - 2 pages
- 15.1.7 Technical Brake Information Sheet - as fitted to Item 15.1.5 Drive ‘B’ - 7 pages
- 15.1.8 CRD operated rotary connections for optic fibre digital or analogue signal transmission,
 see Sheet No. RG00.T.014 REV 01 – 3 pages
- 15.1.9 Roller Limit switches in Feed-in funnel - 1 page
- 15.1.10 Principle layout for Limit Switches on Cable/Hose Reeling Drums,
 Sheet No. RG00.T.010 REV.01 - 1 page
- 15.1.11 Service Instruction – Gear Cam Limit Switch Series 51,
 Type 51/2B-29 BM492 - 11 pages
- 15.1.12 General Arrangement Drawing of Cable Reeling Drum
 Drg. No. **A229.00.00 REV.05** Sheet 2 of 3 as well as Sheet 3 of 3 – total 2 pages
- 15.1.13 Commissioning Report Forms No. RG00.T.013 - 9 pages
- 15.1.14 Tandem Drive for Monospiral CRD’s (see Item 1.1.4.2.3) Sheet No. RG00.T.011 Rev. 0

Please Note:

If in doubt please contact our Specialists on Telephone No. : 011-271-0000 or

E-Mail: powermite.jhb@global.co.za

***Please Note: For the assembly guidance on Powermite Cable Reeling
 Drums please refer to “Assembly Instructions Manual for Monospiral Cable
 Reeling Drum –Power cable/COM 1348”.***

Revision to Drawing Nos. RG00.D.010 Rev 01,
 RG00 D.009 Rev 01 and A229.00.00 REV.05

POWERMITE

Ref. Com. 1348

POWER CABLE REELING DRUM

PSM-2060-FDA 168/167/112/2 – HT600-HMK20-2/112M4

PROJECT: SALDANHA BAY IRON ORE TERMINAL – STACKER/RECLAIMER**METSO MINERALS ORDER NUMBER PO 034149**

RECOMMENDED SPARES LIST

ITEM	PART NO.	DRAWING NO.	DESCRIPTION	QTY INSTALLED	PRICE	CUSTOMER QUANTITY REQUIRED
1	S1348/1		Slipring 600A 3 x Ph + 1 X E	4		4
2	S1161		Slipring 200A 4 x Ph + 1 X E	5		5
3	S1170		Brush holders c/w brush 200A	12		12
4	S1181		Brush holders c/w brush 100A	4		4
5	S2193		Permanent magnet clutch HMK20-93711-200x28 x 24 x K-L with back stop bearing mechanism	1		1
6	S1348/6		Permanent magnet clutch HMK20-93712x200x28x24 K-L without back stop bearing mechanism	1		1
7	S2194		Backstop bearing (for Item 5)	1		1
8	S1348/8		Roller Limit switch, Overtension/slack cable device	4		2
9	S1348/9		Optic fibre rotary coupler OFE/40/12/G1/2	1		1
10	S1348/10		STROMAG Gear cam limit switch	1		1
11	S1348/11	-	Motor IP65 400V 3Ph, 4 KW 4 pole without brake for Drive "A"	1		1
12	S1348/12		Motor IP65 400V 3Ph, 4 KW 4 pole complete with brake for Drive "B"	1		1
13	S1348/13		Main Drive Type FD A168 Gearbox	1		1
14	S1348/14		Splitter Gearbox Type CH 2-1	1		1

1. Check the Transport drum for damages i.e. is I.D. or O.D. still intact
2. Check O.D. and weight of flexible cable which must be in line with CRD - specification
 - 2.i) Powermite Cables are manufactured with a left hand lay and/or a right hand lay. This conductor lay has the natural tendency to make the cable turn either left or right as the case may be. It is therefore important that the first turn of cable be installed on the drum against the left or right hand flange of the CRD as the case maybe. This allows the cable to layer on the drum correctly.
NOTE: If used flexible cable is installed again, see additional instruction under Item 5.
 - 2.ii) Generally when cable is installed onto a forced guidance system, i.e. cable reeling drum, festoon system, gravity fed (spreader) basket etc., the transport drum should be jacked up above ground level. Avoid introducing "S" or 90° bends under all circumstances.
3. Carefully loosen the cable end and pull it off the **Transport Drum (TPD)** without turning or twisting the cable. This can be continued in 2 different methods:-
 - 3.i) the Texoprene™ flexible cable is pulled off the TPD and laid on even ground in a straight intended reeling direction, until the total length is rested on the ground. This should be done with the aid of support pulleys to reduce surface friction thereby easing the pulling forces. Then stress relieve with a bar allowing the cable to release possible tensions and turns. **Do not hinder the cable end from natural rotation (see Pic. 1).**
 - 3.ii) when Texoprene™ flexible cable is reeled off the TPD and wound directly onto the **motorised drum (CRD)** please ensure most importantly that both the diameters are the same i.e. I.D. of the CRD and TPD must be equal. Furthermore, the flexible cable must be wound onto the CRD in the same direction as on the TPD. (see Pic. 2 + 3). Once flexible cable is on Cable Reeling Drum energise the same and spool cable length on the ground, as per item 4.
 If cable, however, shows stress, disconnect cable and stress relieve as stated under 3.i).

PLEASE NOTE:

Method 3.i) should be given preference, particularly if long cable lengths are handled. Avoid "S" bends, changing of directions etc. and the passing over guide rollers. Cable should be wound slowly and with a minimum of tension to avoid undue torsional influences. Long cable lengths have a large winding diameter on TPD when starting to wind off and a comparatively small one when the drum empties. This large difference in winding can create undesirable winding stresses.

Method 3.ii) TPD and CRD must always be in a straight line to each other (Pic 3.1 + 3.2) in order that the flexible cable is not wound at an angle but always in a straight line. Should transferring of flexible cable take place as illustrated under Pic. 3.1 + 3.2 care has to be taken to avoid the cable twisting when transferred from the bottom TPD to the higher standing CRD while maintaining straightness, otherwise as method 3.i).

4. Once the cable is stored on the motorised Powermite™ CRD, connect up electrically both ends of the flexible cable and run the machine two or three times along longitudinal travel while observing the performance of the cable when:
 - a) leaving the CRD
 - b) running through the (are they 85° in angle?) guide rollers/sheaves etc.
 - c) forming the correct catenary to settle on the ground
 - d) the straightness of settling on even ground – check marked cable
 - e) how cable performs when travelling over Centre Feed
 - f) it is tensioned in "winding off" mode, not to exceed 15N/mm² of total powercore cross section.
 - g) where practical a silicone based lubricant can assist the cable passing through the rollers as in b).

<h1>POWERMITE</h1> <p>AFRICA (PTY)LTD</p> <p>POWERMITE HOUSE 92 MAIN REEF ROAD TECHNIKON 1724 ROODEPOORT P O BOX 7745 JOHANNESBURG 2000</p> <p>TELEPHONE : (011) 271-0000 (32 LINES) TELEFAX : (011) 760-3099 EMAIL : powermite.jhb@global.co.za INTERNET : http://www.powermite.co.za</p>	DRAWN J.GIBBONS	APPROVED 	DATE 26/06/94	SHEET NO. 1 OF 2
	SCALE N.T.S.	REV. DATE 07/03/97	DRG. NO. CA00.T.001	REV. 03
THIS DRAWING IS THE PROPERTY OF POWERMITE AFRICA (PTY)LTD AND IS SUBJECT TO RECALL AND MUST NOT BE REPRODUCED OR ITS CONTENTS DIVULGED WITHOUT WRITTEN PERMISSION				

POWERMITE

INSTALLATION INSTRUCTIONS* FOR FLEXIBLE CABLES ONTO CABLE REELING DRUMS (CRD)

*Advice for Trained Personnel only

Should Items a) to f) prove satisfactory the installation can be considered completed but the above described cable performance should be checked at regular intervals by the enduser to see whether the cable does not form any corkscrewing. Should long lay spiralling occur, empty the CRD up to the two last layers, disconnect the cable from the centre feed and stress relief once again as described above under 3.i). Should, however, corkscrewing be evident, stop operation and kindly ask both the CRD and cable supplier for further advice.

5. Should used/old cable be installed check additionally to above recommendations the flexibility and roundness when winding the cable onto a monospiral CRD. Avoid gaps between layers, so as to spare the reel taking shocks while turning. Should this occur, however, reel full length of trailing cable 2 or 3 times on and off to help the used/old cable to straighten.

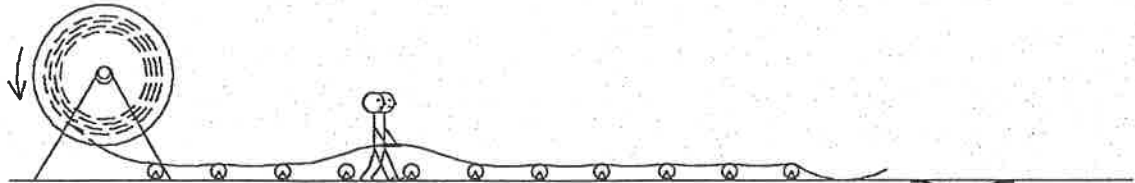

PIC. 1

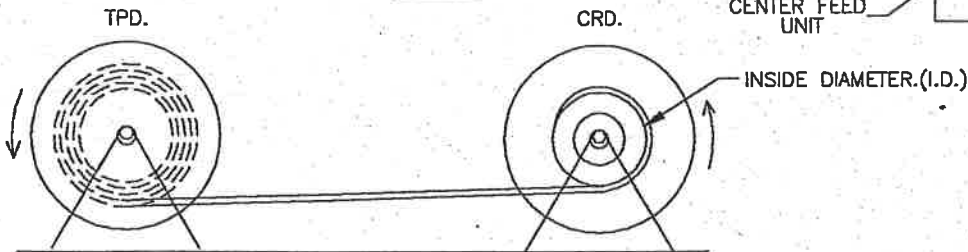

PIC. 2

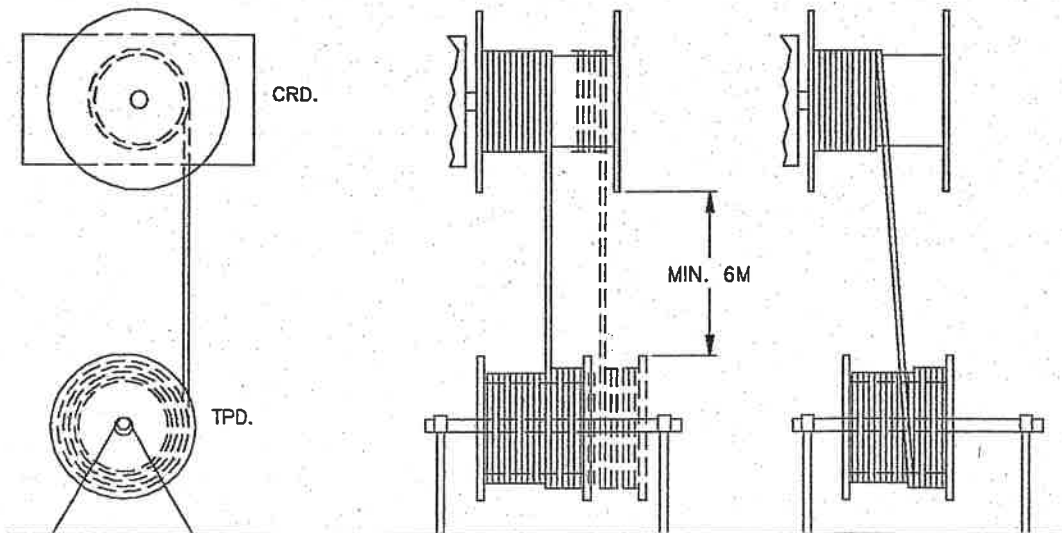

SIDE VIEW.
CORRECT.
PIC. 3.1

FRONT VIEW.
CORRECT.
PIC. 3.2

INCORRECT.
PIC. 3.3

**Under all circumstances CRD Manufacturer's Commissioning instructions must be observed.
Furthermore, electrical connection shall only be done by authorised personnel.**

POWERMITE

AFRICA (PTY)LTD

POWERMITE HOUSE
92 MAIN REEF ROAD
TECHNIKON
1724 ROODEPOORT
P O BOX 7745
JOHANNESBURG 2000

TELEPHONE : (011) 271-0000 (32 LINES)
TELEFAX : (011) 760-3099
EMAIL : powermite.jhb@global.co.za
INTERNET : <http://www.powermite.co.za>

DRAWN
J.GIBBONS

APPROVED

DATE

26/03/93

SHEET NO.

2 OF 2

SCALE N.T.S.

REV. DATE
07/03/97

DRG. NO. CA00.T.001

REV. 03

THIS DRAWING IS THE PROPERTY OF POWERMITE AFRICA (PTY)LTD AND IS SUBJECT TO RECALL AND MUST NOT BE REPRODUCED OR ITS CONTENTS DIVULGED WITHOUT WRITTEN PERMISSION

**RHEYFIRM(RTS)®
(N)TSCGEWTOEUS 3,6/6 kV
3x185+1x95SE+18OFE MM+2x(2x2,5)C**

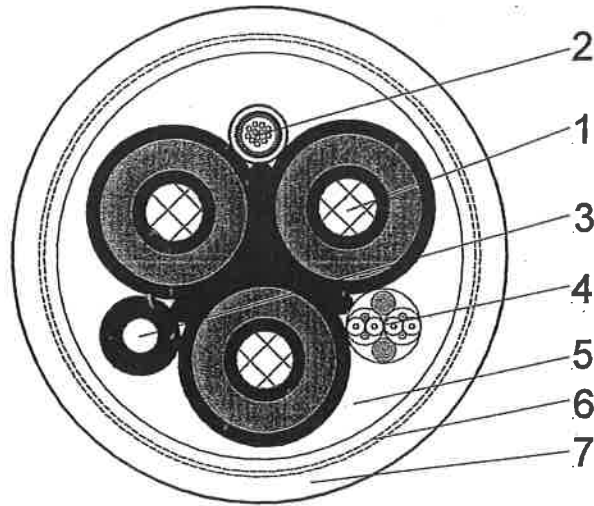

- | | |
|--------------------------------|---|
| Design Materials | In line with DIN VDE 0250 part 813
acc. to DIN VDE 0207 part 20 and 21 |
| 1 Power Conductor | copper conductor, bare, finely stranded, acc. to DIN VDE 0295 class 5; IEC 228 class 5; triple extruded insulation, consisting of: <ul style="list-style-type: none"> - inner conductive layer - insulation of dielectric and thermal high graded RHEYCLEAN HV-EPR, ozone-resistant Ethylene-Propylene-Rubber (EPR), compound better than 3GJ3; - outer conductive layer RHEYSTRIP, cold stripable; all three covers are applied and cross-linked in one process; wrapping of conductive textile tape. |
| 2 Optical Fibre Element | 18 graded-index fibre 50/125 µm |
| 3 Protective Conductor | copper conductor, tinned, finely stranded, acc. to DIN VDE 0295 class 5 warped with semi-conducting tapes |
| 4 Control Cores | copper conductor, tinned, finely stranded, acc. to DIN VDE 0295 class 5; IEC 228 class 5; insulated with dielectric and thermal high graded, ozone-resistant Ethylene-Propylene-Rubber (EPR), compound 3GJ3; color: black with white numbers 1 – 4, paired cores with fine tinned wire braid, covering > 80%, semi-conducting tape over cabling |
| Cabling | Three power cores stranded over a semi-conducting rubber center, one protective-earth core, one screened 2x(2x2,5) element and one fibre-optic element in the outer interstices |
| 5 Inner Sheath | extruded inner sheath filling the interstices
compound GM1b acc. to DIN VDE 0207 part 21 |
| 6 Reinforcement | reinforcement of synthetic threads with very high tensile strength as a protection against crosswise stresses and rockfall. |



RHEYFIRM(RTS)[®]
(N)TSCGEWTOEUS 3,6/6 kV
3x185+1x95SE+18OFE MM+2x(2x2,5)C

7 Jacket chlorinated compound 5GM5 like Polychloroprene (PCP), acc. to DIN VDE 0207 part 21 oil resistant, flame retardant, tear resistant, with low abrasion.

Cable identification:

POWERMITE (N)TSCGEWTOEUS
 3x185+1x95SE+18OFE MM+2x(2x2,5)C 3,3 KV | NEXANS | 2003

Dimensions outer diameter D: 69,6 – 72 mm
 weight: approx. 9,650 kg/km

Electrical Data conductor resistance (at 20°C ambient temp.): 0.106 Ω/km
 current carrying capacity (at 30°C ambient temp.):
 485 A freely ventilated
 461 A touching surfaces
 369 A 1 layer on drum
 281 A 2 layers on drum
 228 A 3 layers on drum

short circuit current (max. short circuit temp. 250°C with bare conductors):
 1s 27.6 kA
 0.5s 39.0 kA

Optical Data *) Attenuation at 850 nm: ≤ 2.8 dB/km
 1300 nm: ≤ 0.8 dB/km
 Bandwidth at 850 nm: ≥ 200 MHz*km
 1300 nm: ≥ 200 MHz*km

*) more techn. information: please contact us

Others bending radius for fixed installation: ≥ 6x D
 barrel diameter of cable reels: ≥ 25x D
 radius of guiding and deflecting rollers and towards the ground: ≥ 15x D
 straight route between 2 bends, if S-shape deflection: ≥ 20x D
 rated temperature: 90 °C

*) correction factors for other ambient temperatures

10°C	20°C	30°C	40°C	50°C	60°C	70°C
50°F	68°F	86°F	104°F	122°F	140°F	158°F
1.15	1.08	1.00	0.91	0.82	0.71	0.58



Test Certificate

FA.No:	01394287	Type - No.	71305846	Order-No.:	495585	Dr.No.:	E229 4493
Type: (N)TSCGEWTOEUS 3x185+95+2x(2x2,5)C+OFE 18G50/125 3,3kV							
Customer	METSO MINERALS						
Order quantity:	m		Deliv.quant.:	329 m			
In accordance with:	VDE0250 T813 angelehnt						
Test/Property	Spec.	unit	Meas. Val./Core-No.				
			1	2	3		
Energy core 185 mm ²							
AC-Voltage Test 5min	10	kV	OK	OK	OK		
PD - Test 1,25 U ₀	<= 5	pC	2,2	2,2	2,4		
Conductor resistance at 20°C	<= 0,106	Ω/km	0,106	0,106	0,106		
Protective conductor 95 mm ²							
Conductor resistance at 20°C	<= 0,210	Ω/km	0,205				
Pilot core 2,5 mm ²							
AC-Voltage Test 5min	2	kV	OK	OK	OK		
Conductor resistance at 20°C	<= 8,21	Ω/km	8,20	8,20	8,20		
Resistance between earth (protection)	<= 500	Ohm	93				
Conductore(s) and outer conduction layers (screens) of phase cores							
Outer diameter	<= 73	mm	69,8	70,3			

Works Mönchengladbach

Datum

25.03.03

Unterschrift

Nexans Deutschland Industries G



Test Certificate

FA No:	01394287	Type No:	71305846	Order No:	485585	Dr. No.:	E219 4494
Type: (N)TSCGEWTOEUS 3x185+95+2x(2x2,5)C+OFE 18G50/125 3,3kV							
Customer		METSO MINERALS					
Order quantity:	m		Deliv. quant:	329 m			
In accordance with:		VDE0250 T813 angelehnt					

Test/Property	Spec	unit	Meas. Val./Core-No		
			1	2	3
Energy core 185 mm ²					
AC-Voltage Test 5min	10	kV	OK	OK	OK
PD-Test 1,25 U ₀	≤ 5	pC	2,3	2,3	2,3
Conductor resistance at 20°C	≤ 0,106	Ω/km	0,105	0,105	0,105
Protective conductor 95 mm ²					
Conductor resistance at 20°C	≤ 0,210	Ω/km	0,208		
Pilot core 2,5 mm ²					
AC-Voltage Test 5min	2	kV	OK	OK	OK
Conductor resistance at 20°C	≤ 8,21	Ω/km	8,18 8,19	8,19	8,19
Resistance between earth (protection) conductore(s) and outhor conduction layers (screens) or phase cores	≤ 500	Ω/mm	98		
Outer diameter	≤ 73	mm	70,5	70,2	

Works Mönchengladbach

Datum

25.03.03

Unterschrift

Nexans Deutschland Industries GmbH



Test Certificate

FA.No:	01394287	Type - No.	71305846	Order-No.	485585	Dr.No.	E219 4497
Type: (N)TSCGEWTOEUS 3x185+95+2x(2x2,5)C+OFE 18G50/125 3,3kV							
Customer	METSO MINERALS						
Order quantity:	329 m	Deliv quant:	329 m				
In accordance with:	VDE0250 T813 angelehnt						
Test/Property	Spec.	unit	Meas.Val /Core-No.				
			1	2	3		
Energy-core 185 mm ²							
AC-Voltage Test 5min	10	kV	OK	OK	OK		
PD-Test 1,25 U ₀	<=5	pC	2,3	2,3	2,3		
Conductor resistance at 20°C	<= 0,106	Ω/km	0,105	0,105	0,105		
Protective conductor 95 mm ²							
Conductor resistance at 20°C	<= 0,210	Ω/km	0,208				
Pilot core 2,5 mm ²							
AC-Voltage Test 5min	2	kV	OK	OK	OK		
Conductor resistance at 20°C	<= 8,21	Ω/km	8,18 8,19	8,19	8,19		
Resistance between earth (protection)	<= 500	Ohm	93				
Conductore(s) and outhter conduction layers (screens)of phase cores.							
Outer diameter	<= 73	mm	70,5	70,2			

Works Mönchengladbach

Datum 25.03.03

Unterschrift

Nexans Deutschland Industries GmbH

DESCRIPTION

MONO SPIRAL CABLE REEL EXPLODED VIEW
FOR LARGE SPLIT REELS - PRINCIPAL ONLY

- 1 - HEX BOLT M12x70
- 3 - HEX NUT M12
- 4 - MOUNTING FLANGE (2 DISCS)
- 5 - REEL FLANGE (2 DISCS)
- 9 - FLAT WASHER M12
- 10 - 10a REEL QUARTER
- 10b - 10b REEL QUARTER
- 15 - REEL I.D. RING
- 17 - 17a REEL QUARTER
- 17b - 17b REEL QUARTER
- 18 - CABLE CLAMP (NOT FIXED TO I.D. RING)
- 22 - CABLE FEED-IN POINT
- 28 - SPRING WASHER M12
- 29 - CRD ADJUSTING CLAMP

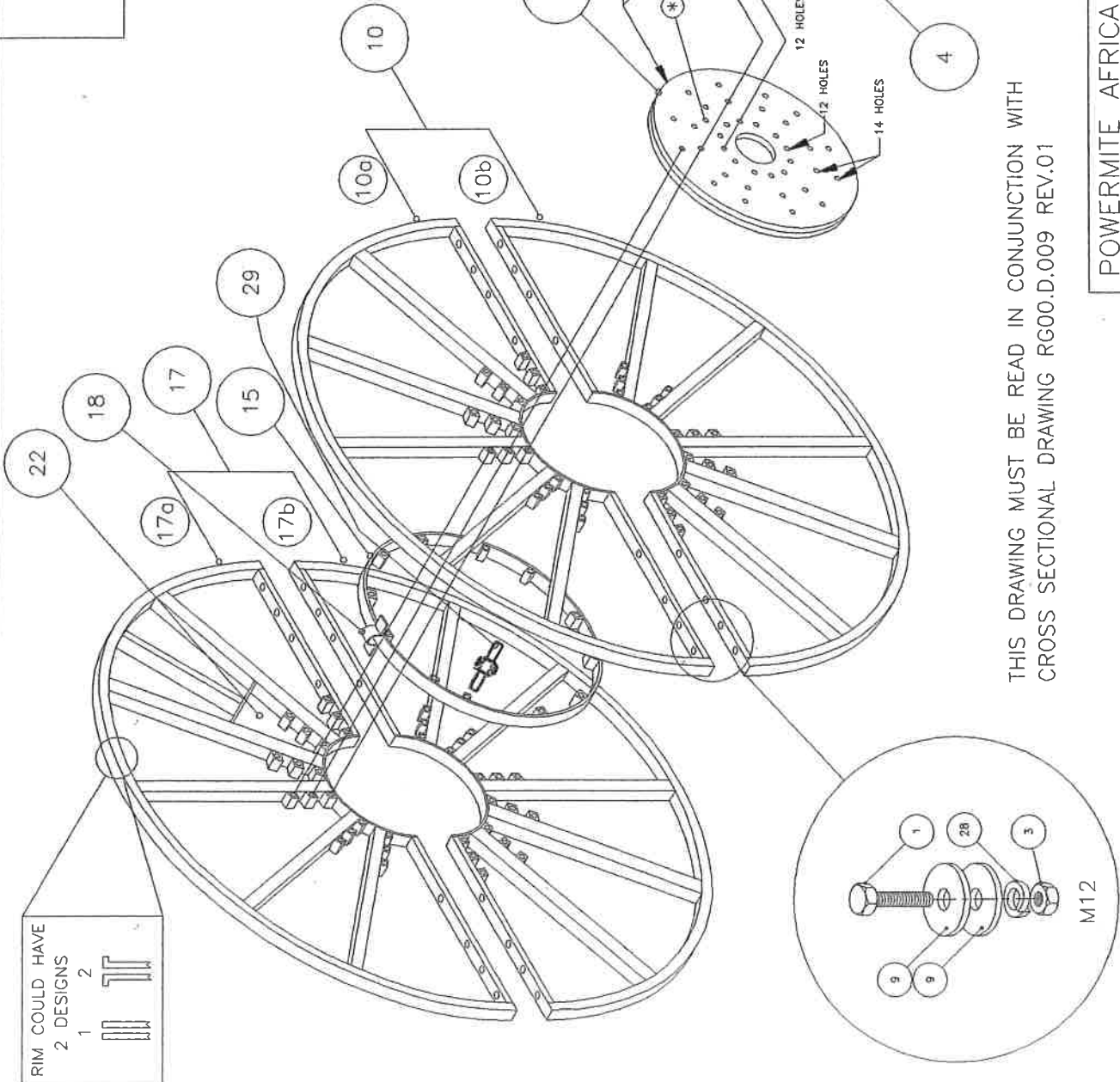

THIS DRAWING MUST BE READ IN CONJUNCTION WITH
CROSS SECTIONAL DRAWING RG00.D.009 REV.01

POWERMITE AFRICA (PTY)LTD.

POWERMITE HOUSE
52 MAIN REEF ROAD
TECHNIKON
1724 ROOBEPOORT
P O BOX 7745
JOHANNESBURG 2000

TELEPHONE : (011) 271-0000 (32 LINES)
TELEFAX : (011) 760-3099
EMAIL : powermite.jhb@global.co.za
INTERNET : http://www.powermite.co.za

METSU PROJECT: SALSTACK - OUR COM.NO. 1348

DRAWN BY S.GOMERSALL
APPROVED BY J-17-03
DATE 07/05/03
STOCK NO.

SCALE N.T.S. TOL. DRG. NO. RG00.D.010 REV. 01
THIS DRAWING IS THE PROPERTY OF POWERMITE AFRICA (PTY)LTD AND IS SUBJECT TO THEIR RECALL AND MUST NOT BE REPRODUCED OR ITS CONTENTS IMAGED WITHOUT WRITTEN PERMISSION

REV.	DATE	DESCRIPTION	BY	CHK.

POWERMITE AFRICA (PTY) LTD

METSO MINERALS REF.	: CA10310
METSO MINERALS PROJECT NAME	: SALDANHA BAY IRON ORE TERMINAL – STACKER/RECLAIMERS
METSO MINERALS ORDER NO.	: PO 034149

POWERMITE REF.: COM NO. 1348

ASSEMBLY INSTRUCTION MANUAL

FOR POWERMITE CABLE REELING DRUM FOR

POWER CABLE

TYPE: PSM2060/FDA168/167/112/2-HT600-HMK20/2/112M4

MONOSPIRAL

This 5 page Manual is the intellectual property of Powermite and no part of this publication may be reproduced or utilised in any form or by any means without the written permission of the publisher.

These Assembly Instructions must be read in conjunction with the Installation, Operation and Maintenance Instruction Manual for Powermite Cable Reeling Drums – Amendment 1 dated 30th June, 2003

Date: 9th May, 2003

ASSEMBLY INSTRUCTIONS FOR CABLE REELS,
MONOSPIRAL, SPLIT DESIGN

1. **GENERAL INFORMATION:**

The function of the Cable Reeling Drum (CRD) is to automatically wind the "reeling drum duty" cable on or off and in this way keep the mobile machine energised.

The reeling capacity of the CRD is such, that it will take the operational cable payout, plus 2 windings for tension relief.

N.B. All the Item numbers given in brackets i.e. (10) below, refer to the corresponding positions on Drg. RG00.D.010 REV. 01 (exploded view for large split reels) and RG00.D.009 REV 01 (Cross sectional view, after assembly of Monospiral Reel to drive hub).

2. **REEL COMPONENTS:**

The reel is delivered dis-assembled and comprises of the parts below as depicted on the Drgs. **RG00.D.010 REV. 01** and **RG00.D.009.REV. 01**

- 2.1 first reel half (10) (with three different PCD row of holes of 20mm) divided up into quarter sections (10a) and (10b).
- 2.2 second reel half (17) (with three different PCD row of holes of 20mm) divided up into quarter sections (17a) and (17b).
- 2.3 one flat ring (15) which form the I.D. of the reel to which cable clamp (18) will have to be fitted into the correct space to match area 22 on Drg. **RG00.D.010 Rev. 01**
- 2.4 one reel flange (5), consisting of 2 discs – with 3 rows of holes (most inner PCD = 12 - M16 holes, 2nd inner PCD = 14 – M20 holes, outer PCD = 12 – M20 holes)
- 2.5 one mounting flange (4), already fitted to taper lock hub consisting of 2 discs pre-torqued to the hub with 530 Nm – with 3 rows of holes (most inner PCD = 12 – M20 holes, 2nd inner PCD = 12 – M16 holes, outer PCD = 14 – M20 holes)

Please Note: A) When assembling mounting / reel flanges (4) and (5) ensure to line up the M12 alignment hole on each flange to achieve proper alignment of all the other holes on reel flanges (4) and (5).

B) PCD = Pitch Cycle Diameter

- 2.6 32 – bolts M12 x 70 (1), flat washers (9), spring washers (28) and nuts (3) are to be used to bolt quarter sections (10a, 10b, 17a, 17b) together
- 2.7 12 – bolts M20 x 130 (6), flat washers (7) are used to fit mounting flange (4) to hub with torque 530 Nm – (already factory fitted).
- 2.8 12 – bolts M16 x 70 (11), flat washers (24), spring washers (25) and nuts (26) are used to bolt 2 discs of mounting flange (4) and reel flange (5) together.
- 2.9 14 – adjusting threaded rods M20 x 400 (12), with flat washers (7), spring washers (2) and nuts (8/13/19/20) are used to hold reel half (10) and (17) and reel flange (5) with mounting flange (4) together.

Revision of Drawing Nos. RG00 D.010 Rev 01 and RG00 D.009 Rev 01

- 2.10 14 - adjusting threaded rods M20 x 380 (23) with flat washers (7), spring washers (2) and nuts (8/13/19/20) are used to hold reel half (10) and (17) and reel flange (5) together.
- 2.11 12 - threaded rods M20 x 350mm (14) with flat washers (7) spring washers (2), spacer washer (16) and nuts (8/21) are used to hold reel half (10), I.D. ring (15) and reel half (17) together)
Note: Spacer washers (16) are provided for “width of Reel adjustment”.

3. ASSEMBLY SEQUENCE OF THE MONOSPIRAL CABLE REEL PARTS:

For large split reels:

Step 1: First assemble two sections of reel quarters (10a) and (10b) to make up the first half-reel (10) and repeat (17a) and (17b) to make up the second half-reel (17) using hardware of Item 2.6.

Care must be taken to ensure that the reel halves with the matching marking e.g. AA, BB etc are joined together in every case. The reel sections (10a), (10b), (17a) and (17b) are joined by the hexagonal bolts M12 (1) with flat washers (9), with spring washers (28) and hex nuts (3).

Refer Drg. RG00.D.010 REV. 01

Step 2: Place the reel flange (5) on trestles, with welded and painted markings facing up, ensuring that all holes are accessible from the bottom.

Step 3: Mounting the first reel half (10)

- 3.1 Place reel half (10) (ensuring that the overhang of rim design 2 faces downwards) onto reel flange (5) and line up holes by aligning painted markings. Now insert from top adjusting threaded rod M20 x 400mm (12) through all relevant holes { i.e. most inner of (10) and 2nd inner of (5)}. Fit flat washer (7) and nut (19)
- 3.2 Insert from the top adjusting threaded rod M20 x 380mm (23) after you have fitted flat washer (7) and nut (19) (2) and full nut (20) on the underside.

Step 4: Fit I.D. ring (15) aligning painted markings to outer row of holes of reel half (10) by inserting threaded rod M20 x 350mm (14) and fitting flat washer (7), spring washer (2) and nut (21) to underside. Then place spacer washer (16) over threaded rod (14) to rest on top of I.D. ring (15).

Step 5: Now return to Step 3.1 and fit nut ((13) and flat washer (7) in such a position to place it approx. 50mm away from existing nut (19). Repeat the same for adjusting threaded rod (23) but fit flat washer (7), spring washer (2) and nut (27) to underside and tighten securely.

Step 6: Position reel half (17) on top of I.D. ring (15) ensuring alignment of colour marking and holes. The overhang of the rim design 2, as seen on the spokes, must now face upwards to achieve an even gap for cable movement between reel halves.
Place all flat washers (7), spring washers (2) and nuts (8) onto both the adjusting threaded rod (12) and (23) and threaded rod (14) and hand tighten same.

Step 7: 7.1 Hoist reel assembly to drive unit and align flanges (4) and (5).

Please Note: a) (4) is already fitted to drive unit.

b) ensure that the 1 – M12 alignment hole on flanges (4) and (5) correspond!

7.2 Fit now flat washer (7), spring washer (2) and nut (20) and tighten same securely.

7.3 The last set of 12 – M16 bolts (11) must now be fitted into aligned holes
{i.e. 2nd inner row holes of flange (4) and further into the holes of flange (5) most inner row}
Fit flat washer (24), spring washer (25) and nut (26) and tighten securely.

7.4 Tighten securely nuts on threaded rod (14) ensuring that an equal length of rod is protruding from the nuts on each side.

Step 8: The reel has now to be adjusted to achieve parallelness of the reel halves (10) and (17). Proceed to securely tighten the nuts (13) and (8) to achieve a gap between the rim of the reel halves of 77mm.

Step 9: Once Step 8 is completed fit the CRD adjustment clamps underneath the Reel ID ring (15) as depicted and continue with the cable installation. You would normally have a re-adjustment after the installation of the cable for the parallelness of the reel and that would be partly facilitated by the 11 clamps and the appropriate bolts. (see Drawing RG00.D.009 Rev 01)
These clamps remain on the CRD after commissioning.

A final check should be conducted on the parallelism of dimension 'b' all the way round the Reel. If the parallelism has not been achieved, the cable reeling drum must be fine adjusted with the adjusting threaded rods (12) and (23) as well as the CRD adjustment clamps to arrive finally at parallelness of the reel halves (10) and (17) with the prescribed gap of 77mm

DESCRIPTION

CROSS SECTION AFTER ASSEMBLY OF
MONO SPIRAL CABLE REEL TO DRIVE HUB

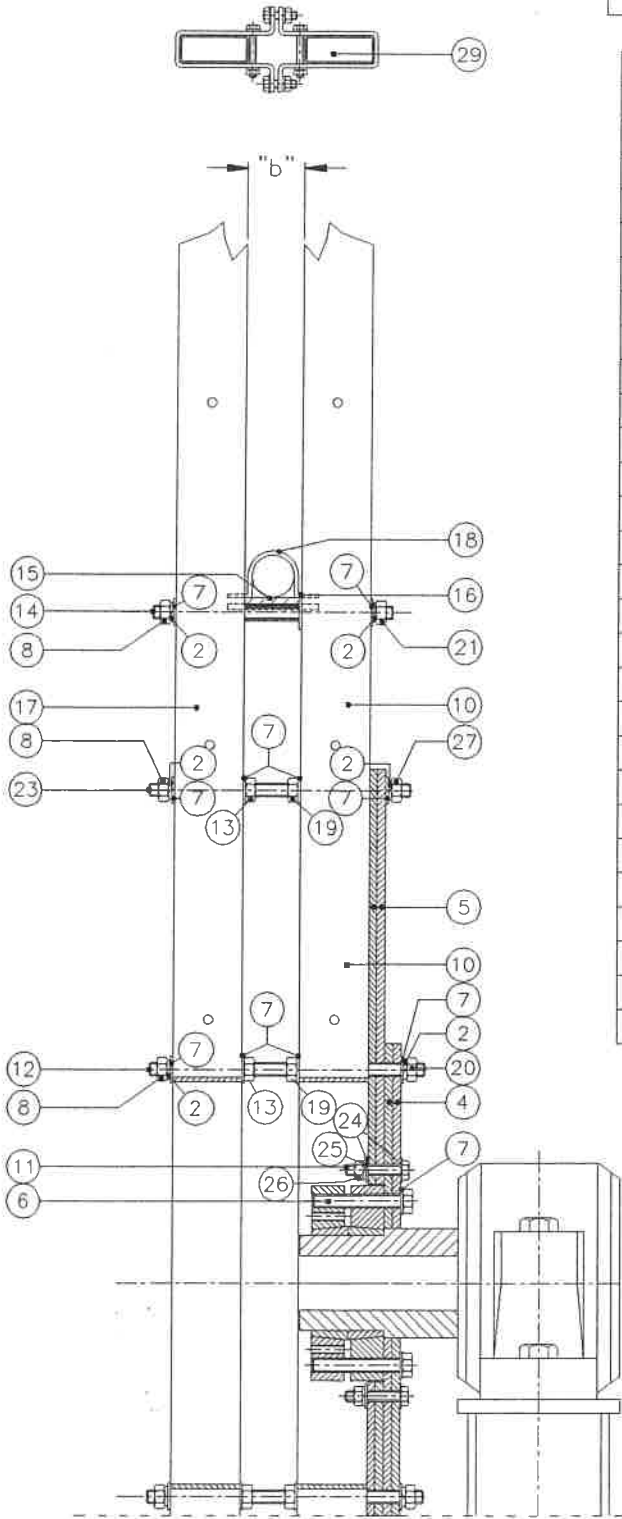

29	CRD ADJUSTING CLAMP
27	HEX NUT M20
26	HEX NUT M16
25	SPRING WASHER M16
24	FLAT WASHER M16
23	2nd ADJUSTING THREADED ROD M20x380
*22	CABLE FEED-IN POINT
21	HEX NUT M20
20	HEX NUT M20
19	HEX NUT M20
18	CABLE CLAMP WITH 2 - M12
17	2nd REEL HALF
16	SPACER WASHERS M20x50x3
15	REEL - I.D. RING
14	THREADED ROD M20x350
13	HEX NUT M20
12	1st ADJUSTING THREADED ROD M20x400
11	HEX BOLT M16x70
10	FIRST REEL HALF
*9	FLAT WASHER M12
8	HEX NUT M20
7	FLAT WASHER M20
6	HEX BOLT M20x130 HTFG TORQUED TO 530Nm
5	REEL FLANGE (2DISCS)
4	MOUNTING FLANGE (2 DISCS) FACTORY FITTED
*3	HEX NUT M12
2	SPRING WASHER M20
*1	HEX BOLT M12x70
ITEM.	DESCRIPTION

* NOT VISIBLE ON THIS DRAWING - SEE DRAWING RG00.D.010 REV.01

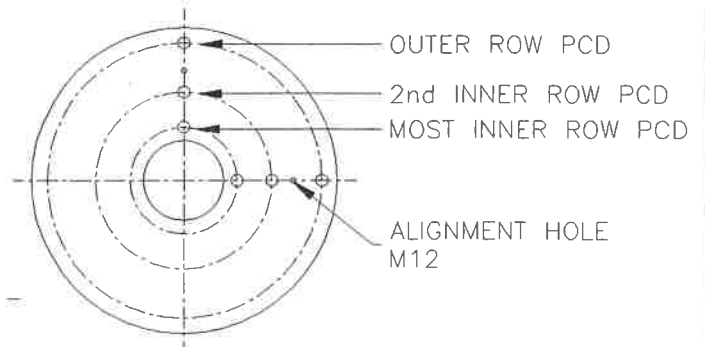

MOUNTING FLANGE (4) AND REEL FLANGE (5)

THIS DRAWING MUST BE READ IN CONJUNCTION WITH
EXPLODED VIEW DRAWING RG00.D.010 REV.01

POWERMITE AFRICA (PTY)LTD.

METSO PROJECT: SALSTACK-OUR COM.NO. 1348

POWERMITE HOUSE
92 MAIN REEF ROAD
TECHNIKON
1724 ROODEPOORT
P O BOX 7745
JOHANNESBURG

TELEPHONE : (011) 271-0000 (32 LINES)
TELEFAX : (011) 760-3099
EMAIL : powermite.jhb@global.co.za
INTERNET : http://www.powermite.co.za

DRAWN S.GOMERSALL	APPROVED 5-12-03	DATE 06/05/03	STOCK NO.
SCALE N.T.S.	TOL:	DRG. NO. RG00.D.009 REV- 01	

THIS DRAWING IS THE PROPERTY OF POWERMITE AFRICA (PTY)LTD AND IS SUBJECT TO THEIR RECALL
AND MUST NOT BE REPRODUCED OR ITS CONTENTS DIVULGED WITHOUT WRITTEN PERMISSION

**POWERMITE****ELECTRIC MOTORS**

Nr.: 4kW 4P

Date: 04-FEB-2003

DATA SHEET

Three-phase Induction Motor - Squirrel Cage

Customer : Powermite / Metso Salstack COM 1348
 Motor line : Multivoltage

Frame : 112M
 Rated Output : 4.00 kW
 Frequency : 50 Hz
 Poles : 4 poles
 Full load speed : 1430 rpm
 Slip : 4.67 %
 Voltage : 380/660 V
 Full load current : 7.88/4.54 A
 Locked rotor amps : 55.2/31.8 A
 Locked rotor current (I_L/I_n) : 7.00
 No load current : 3.20/1.84 A
 Full load torque : 26.7 Nm
 Locked rotor torque : 250 %
 Breakdown torque : 260 %
 Design : N
 Insulation class : F
 Temperature rise : 80 K
 Locked rotor time : 14 s
 Service factor : 1.00
 Duty cycle : S1
 Ambient temperature : 40 °C
 Altitude : 1000 m.a.s.l
 Degree of protection : IP55
 Approx. weight : 45.5 kg
 Moment of inertia : 0.0188 kgm²
 Noise level : 55 dB(A)

	D.E.	N.D.E.	Load	cos ϕ	Efficiency(%)
Bearings	6307-ZZ	6206-ZZ	100%	0.89	86.7
Regreasing int.	—	—	75%	0.84	88.0
Grease amount	—	—	50%	0.74	86.5

Comments:

- 1.) This POWER CABLE REELING DRUM is driven by 2 motors as per this specification ie: 1 motor for Drive "A" and 1 motor for Drive "B" -- see Powermite Manual item 15.1.5
- 2.) The Drive "B" motor has a holding brake c/w micro switch fitted as described in the Powermite Manual under the heading Item 15.1.7

*The values shown are subject to change without prior notice.

POWERMITE HOUSE TELEPHONE : 011-270-0000 (34 Lines)
 92 MAIN REEF ROAD TELEFAX : 011-760-3099
 TECHNIKON E-mail : powermite.jhb@global.co.za
 1724 ROODEPOORT Web site : www.powermile.co.za
 P.O. BOX 7745
 JOHANNESBURG 2000

POWERMITE



POWERMITE

ELECTRIC MOTORS

Nr.: 4kW 4P

Date: 04-FEB-2003

PERFORMANCE CURVES RELATED TO SPEED

Three-phase Induction Motor - Squirrel Cage

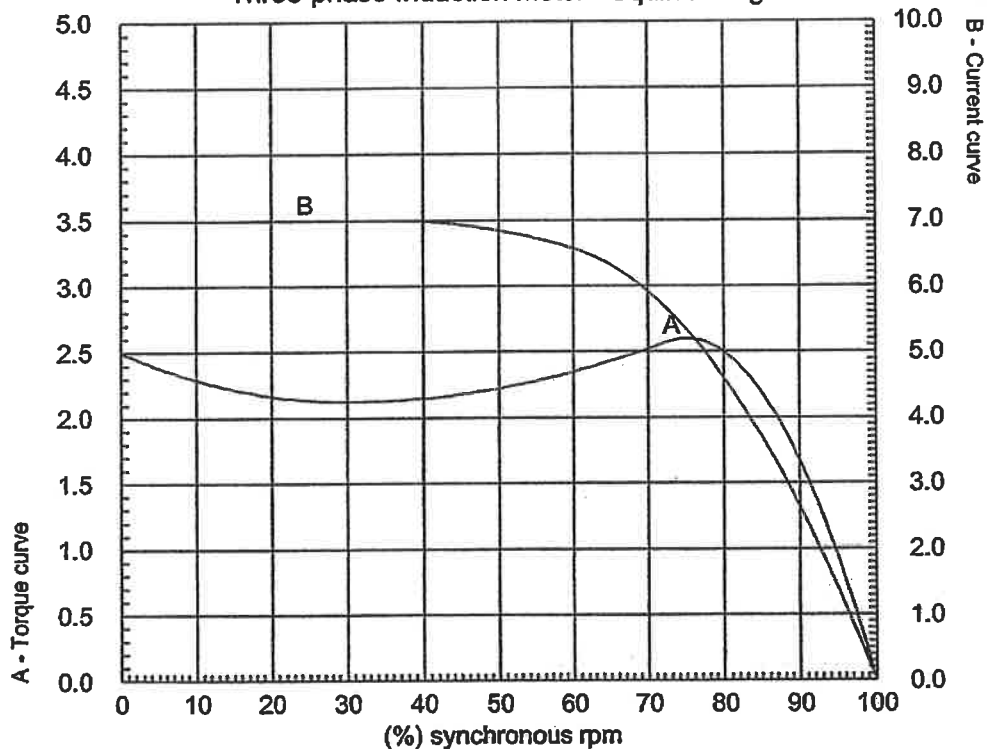

Customer	: Powermite / Metso Salstack COM 1348
Motor line	: Multivoltage

Rated Output	: 4.00 kW	Locked rotor current (I _l /I _n)	: 7.00
Frame	: 112M	Duty cycle	: S1
Full load speed	: 1430 rpm	Service factor	: 1.00
Frequency	: 50 Hz	Design	: N
Voltage	: 380/660 V	Locked rotor torque	: 250 %
Insulation class	: F	Breakdown torque	: 260 %
Full load current	: 7.88/4.54 A		

Comments:

See page 1 of 5

POWER REELING DRUM (CRD)

*The values shown are subject to change without prior notice.

POWERMITE HOUSE TELEPHONE : 011-270-0000 (34 Lines)
 92 MAIN REEF ROAD TELEFAX : 011-760-3099
 TECHNIKON E-mail : powermite.jhb@global.co.za
 1724 ROODEPOORT Web site : www.powermite.co.za
 P.O. BOX 7745
 JOHANNESBURG 2000





POWERMITE

ELECTRIC MOTORS

Nr.: 4kW 4P

Date: 04-FEB-2003

PERFORMANCE CURVES RELATED TO RATED OUTPUT

Three-phase Induction Motor - Squirrel Cage

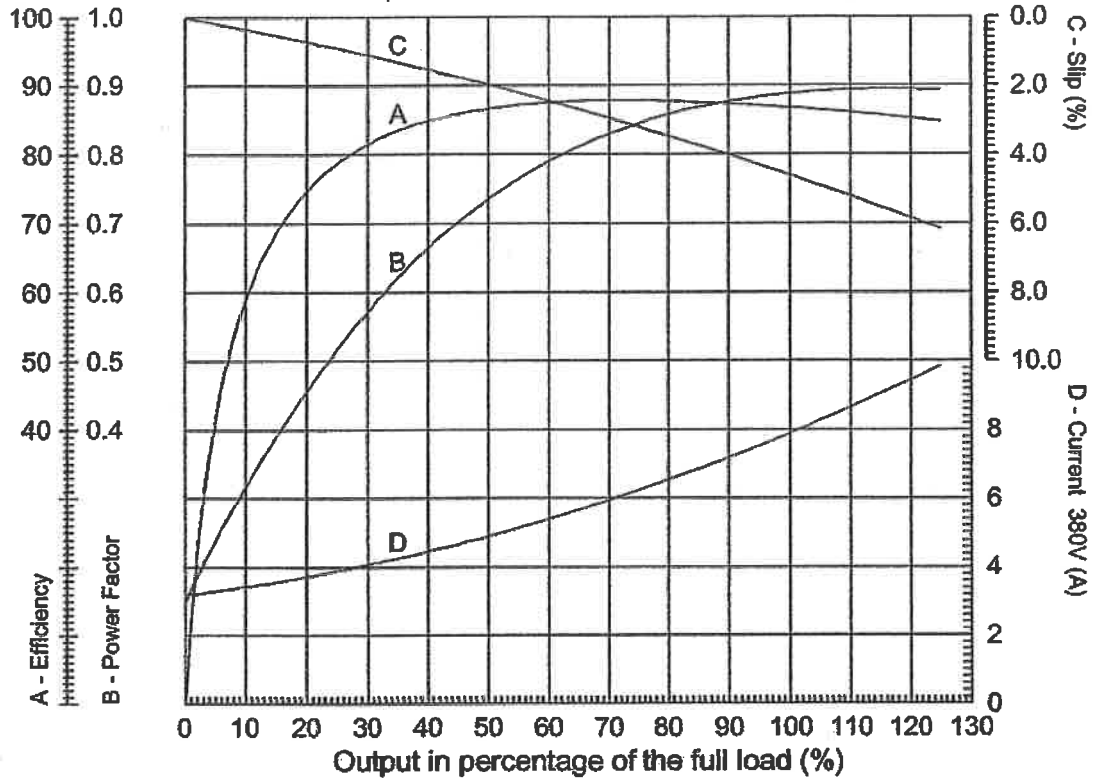

Customer : Powermite / Metso Salstack COM 1348
 Motor line : Multivoltage

Rated Output	: 4.00 kW	Locked rotor current (I _l /I _n)	: 7.00
Frame	: 112M	Duty cycle	: S1
Full load speed	: 1430 rpm	Service factor	: 1.00
Frequency	: 50 Hz	Design	: N
Voltage	: 380/660 V	Locked rotor torque	: 250 %
Insulation class	: F	Breakdown torque	: 260 %
Full load current	: 7.88/4.54 A		

Comments:

See page 1 of 5

POWER REELING DRUM (CRD)

*The values shown are subject to change without prior notice.

POWERMITE HOUSE TELEPHONE : 011-270-0000 (34 Lines)
 92 MAIN REEF ROAD TELEFAX : 011-760-3099
 TECHNIKON E-mail : powermite.jhb@global.co.za
 1724 ROODEPOORT Web site : www.powermite.co.za
 P.O. BOX 7745
 JOHANNESBURG 2000



1 2 3 4 5 6 7 8

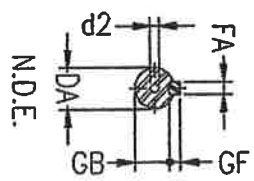
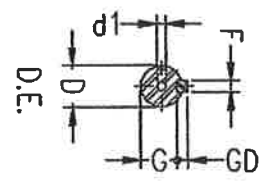
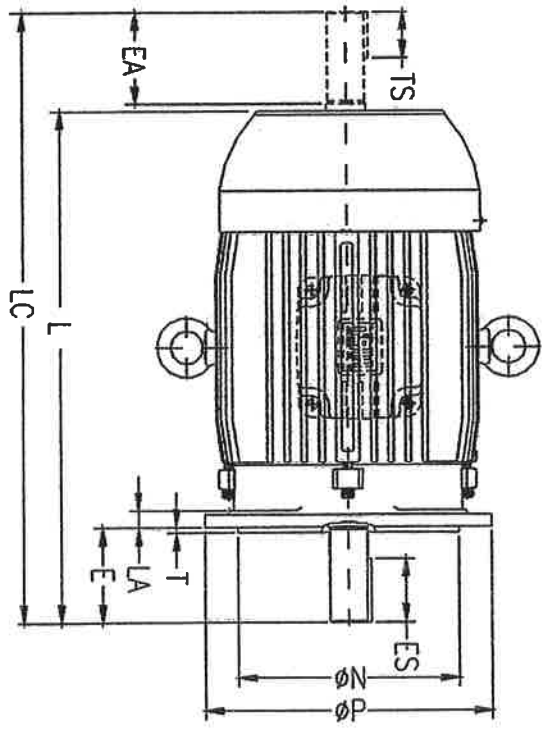
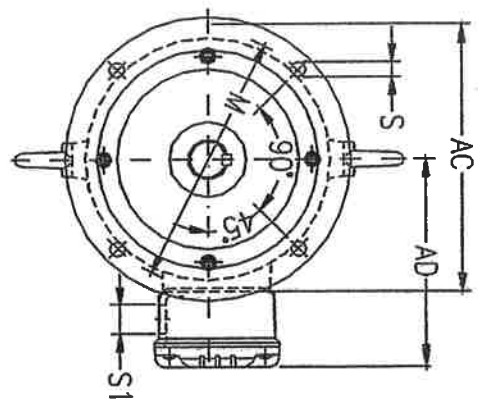

A	AA	AB	AC	AD
---	---	---	222	180
B	BA	BB	C	CA
---	---	---	---	---
D	E	ES	F	G
2816	60	45	8	24
GD	DA	EA	TS	FA
7	24/6	50	36	8
GB	GF	H	HA	HC
20	7	---	---	---
HD	K	L	LC	S1
---	---	393	448	M25x1.5
d1	d2	Flange	C	LA
DM10	DM8	FF-215	70	12
M	N	P	T	S
215	180	250	4	15
A	Holes			
45°	4			

POWERMITE

POWER CABLE REELING DRUM (CRD)

Customer: Powermite / Metso Salstack COM 1348
Multivoltage

Three-phase Induction Motor
Frame 112M - IP55

04-FEB-2003
4KW 4P



Dimensions in millimetres

Version 4.05



POWERMITE

Type Test Report
Three-Phase Induction Motors

Nº: PT04276

Date: 05/07/2002

Customer : Powermite / Metso Salstack COM 1348 POWER REELING DRUM (CRD)
Order : -
Assembly : B3L Approximate weight : 45.5 kg

IDENTIFICATION

Model : 112M Design : N Ins. Class : F
Enclosure : IP55 Time rating: S1 D.T. (K) : 80
Item : -

Voltage(V)	Power(kW)	Frequency(Hz)	Current(A)	Full Speed(rpm)	Power Factor
380	4.00	50	7.88	1430	0.89
660	4.00	50	4.54	1430	0.89
400	4.00	50	7.62	1440	0.87
690	4.00	50	4.42	1440	0.87
415	4.00	50	7.64	1445	0.84
440	4.80	60	8.23	1710	0.89
480	4.80	60	7.99	1720	0.84

TESTS

Resistance Measurement

Resistance : 2.36000 Ohms Ambient Temp. : 23.20 °C Connection : Delta

No Load Test

Voltage : 400 V Frequency : 50 Hz Current : 3.55 A Losses : 257.60 W

Locked Rotor Test

Voltage : 400 V Frequency : 50 Hz Current : 63.21 A Power : 29.33 KW
TI/Tn : 3.01 Full load Torque(Tn) : 2.73 mkgf (1 mkgf ou mkp = 9.813 Nm)

Load Test

Voltage : 400 V

Frequency : 50 Hz

% of Full Load	Current (A)	Speed (rpm)	Efficiency (%)	Power Factor
50	5.01	1478	85.1	0.68
75	6.34	1462	86.4	0.80
100	7.91	1444	85.8	0.86

Temperature rise by resistance at 100 % of Full Load = 63.63 K

Break-Down Torque Test

Voltage : 400 V Frequency : 50 Hz Tb/Tn : 2.94

High Voltage Test 1.80 kV for : 60 Seconds

Insulation Resistance 1000.0 MOhms Ambient Temp. : 23.00 °C

The values included in this report refer to an unit electrically identical.



General Specification

In case that the torque has to be changed at the installation or after a certain operation time please follow the below mentioned description.

Torque Adjustments

Both clutch and motor can remain mounted. Just remove the protection grating. The adjustment is done from outside.

- Turn off power.
- Secure reel against run-off (block).
- Remove protection grating „4“ from the clutch cap
- Rotate the magnetic clutch until type label „10“ is visible
- Loosen hexagon bolt screw(s) „5“ until flange „7“ can be turned freely (There are 2 screws 180° misaligned at HMK 8 and HMK 12.5). The cylinder head screws „8“ remains tightened.
- Hold clutch while rotating flange „7“.
Tool : Put round bar into blind holes „9“.
The clutch parts are moving towards or from each other according to the rotating direction.

Rotating the clutch parts from each other means a **reduction** of the torque !

Rotating the clutch parts towards each other means **increasing** the torque !

- By means of a comparison measurement of groove „S“ before and after the clutch adjustment the change of the torque can be determined.

One rotation at flange „7“ corresponds to

HMK 0.63	app. 0,25 Nm
HMK 1.25	app. 0,5 Nm
HMK 2	app. 0,5 Nm
HMK 3.2	app. 1 Nm
HMK 5	app. 1.5 Nm

HMK 8	app. 2 Nm
HMK 12.5	app. 3 Nm
HMK 20	app. 2 Nm
HMK 25	app. 4 Nm

- Important: Check axial pitch (see page 2/2)
- After having reached the correct torque (cable traction), i.e. before turning the motor on, turn flange „7“ that way that two blind holes „9“ in flange „7“ are aligned symmetric to type label „10“ (see figure on page 2/2). Then tighten the hexagon bolt screws „5“ so that these can be easily fastened into the drilling.
- Re-mount the protection grating „4“. After removing the run-off safety device the reel can be used again.

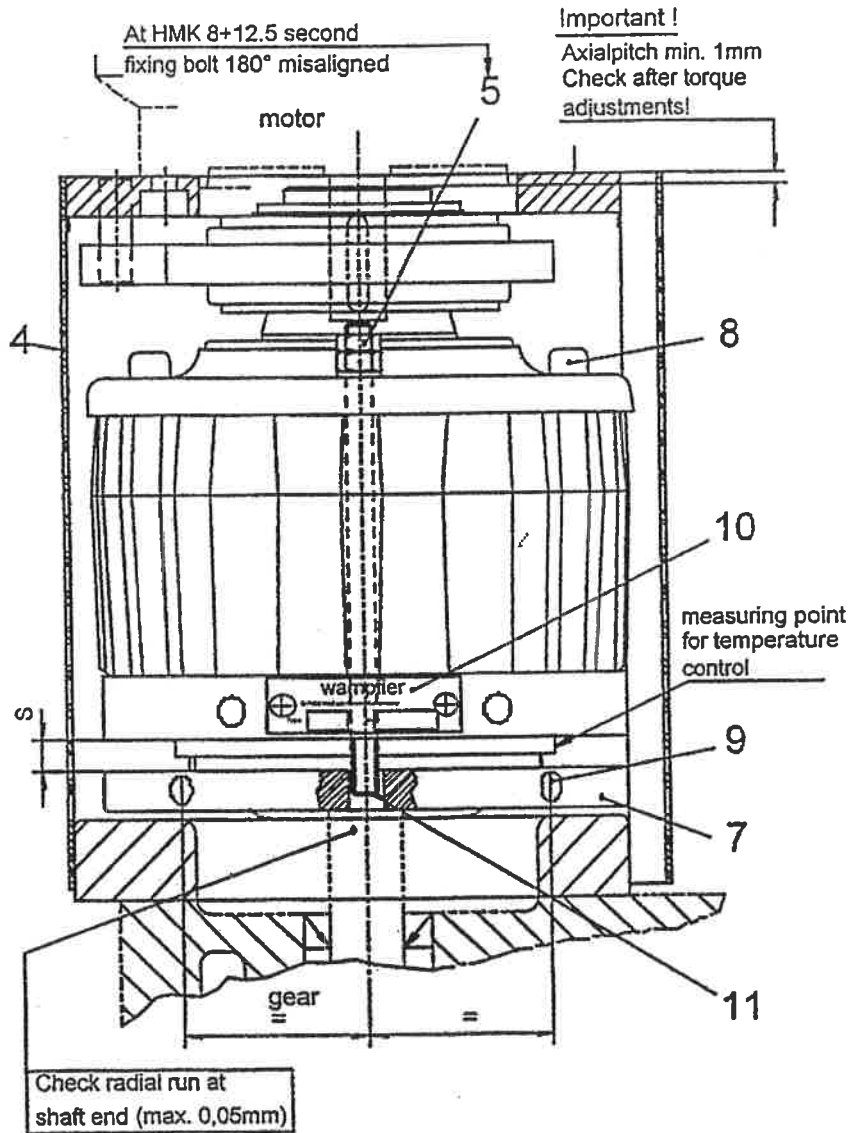

DRAWN S.GOMERSALL	APPROVED 	DATE 07/04/97	SHEET NO. 2 OF 2
SCALE N.T.S.	REV. DATE	DRG. NO. RG03.T.001	REV. 0

Technical Information Sheet

Spring-applied single-disc brake
Ready for fitting or for mounting
for D.C. operation
for dry running

77 600 .. A00

77 600 .. A15

This spring-applied brake is an electromagnetic device intended for dry running, where the dynamic effect of an electromagnetic field is exploited to compensate the braking effect produced by the spring. The brake grips in absence of current and releases under current. If necessary, it is possible to eliminate the braking effect mechanically by means of an additional hand release.

CE

The brake complies to the regulations for low tension 73/23/EWG. The observance of the EMV regulation 89/336/EWG is to be ensured by the user through corresponding switching devices and/or controls. When using the recommended BINDER fittings, refer to the corresponding Technical Information Sheet for the observance of the respective EMV regulations. The products have been manufactured and tested to DIN VDE 0580 October 1994. When using the brakes, please observe the "General Technical Information" (please refer to current BINDER catalogue regarding Drive Engineering) and the "Operating Instructions 77 600..A00".

Standard nominal voltages:

24V-, 102V-, 178V-
Brake with silicon rectifier: 230 or 400V 1 ~ 40 .. 60 Hz

Different models:

77 600 .. A00: Work brake
77 600 .. A15: No-work brake with importantly increased admissible torque M_4 (possibility of 3 emergency stops per hour, evenly distributed)

Protection: IP 54

(IP 55 if mounted under fan cowl; in case of through shaft, adjustment ring must be sealed).

Increased protection against corrosion possible.

Technical Data

The response times are valid for D.C. switching under operating temperature, nominal tension, and nominal air gap. In case of A.C. switching, the coupling time t_1 will increase its value approx. by 6.

The time from the switching on of the current up to the reduction of the torque to 10 % of the nominal torque M_2 represents the disconnection time t_2 . The coupling time t_1 is the time starting with the disconnection of the current up to reaching the nominal torque M_2 .

Maximum switching effort per switching operation W_{max} in relation to the switching number per hour Z (values valid for $n = 1500 \text{ min}^{-1}$)

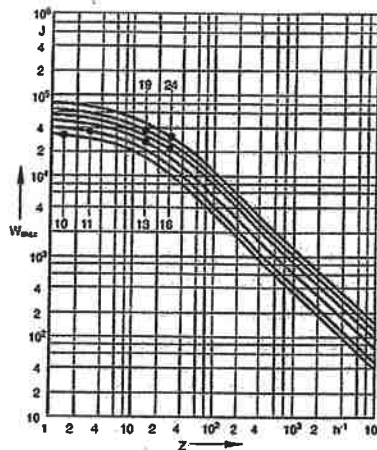

Insulation Class: F

Connections

Litz wires
Adapter box for rectifier
One-way rectifier
Bridge rectifier
Over-excitation rectifier

Explanations regarding connections:

With silicon rectifier
The excitation winding is rated, depending whether the operating current is 230 or 400 V A.C., at 102 or 178 V D.C.

With silicon rectifier with over-excitation
The excitation winding is rated, depending whether the operating current is 230 or 400 V A.C., at 102 or 178 V D.C. The over-excitation, that is limited in time (double nominal tension of the brake), will cause a reduction of the disconnection time t_2 to about 40%.

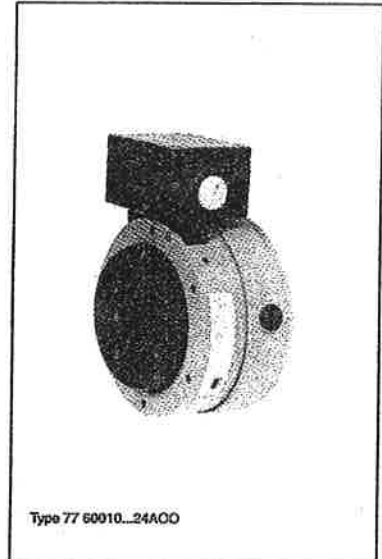

Microswitch: Starting with size 13
Protective lid for microswitch starting size 16.

Explanations regarding microswitch:
The attached microswitch is rated at 250V 1~/15 A or at 24V/6A. In the control line of the motor contactor it will prevent the motor from starting if the brake is not released.

Centering shoulder: for attachment of pilot generator (standard)

Accessories:
Hand release
Fixing bolts

Subject to design modifications.

Please observe ordering data.

The maximum switching energy P_{max} is the switching effort W that can be achieved by the brake within one hour. Please refer to the diagram for the values of the maximum switching effort per switching operation W_{max} . The values of P_{max} and W_{max} are reference values and are valid for the integration between the B-end shield and the motor fan or for mounting onto motors. All data are valid for mounting or attachment on horizontal shafts. In case of vertical operation, please contact manufacturer. The

torque can be modified via the adjustment ring on the back of the brake (please refer to diagram in Operating Instructions 77 600 .. A 00). The values indicated for the nominal torque M_2 and for the admissible torque M_4 will be reached in a run-in state at operating temperature and during dry running. The values of the switching moment M_1 depend on the speed. The torque will be reduced on oily or greasy friction surfaces.

Size	Nominal torque (Standard)		Lowest and highest possible nominal torque type A00 with largest (E_{max}) and smallest (E_{min}) clearance of adjustment ring	Max. Rotation n_{max} min ⁻¹	Max. switching energy		Nominal energy				Response times				Inertia torque Hub and friction disc J kgcm ²	Service life (reference values)			Weight m kg
	Type A00	Type A15			Attachment	Mounting	Type A00		Type A15		Coupling time		Disconnection time			Type A00	Type A15	Type 77 600..2)	
	M_2 with n Nm min ⁻¹	M_4 Nm					M_2 min - max Nm Nm	P_N	P_S	P_N	P_S	t_1	t_2	t_1		t_2	W_{tot}	W_{tot}	
10	8 250	15	4 - 9	5400	250	350	23	47	68	130	15	15	75	45	1.22	80	85	1.8	
11	14 250	25	7 - 15.5	5000	320	480	26	57	79	165	30	20	90	60	1.75	125	120	2.9	
13	32 250	50	16 - 35.5	4000	460	720	38	69	130	235	40	30	130	80	5	175	165	4.3	
16	60 250	100	30 - 66	3500	570	930	60	96	155	255	85	50	145	120	14	345	315	8.6	
19	130 125	200	65 - 143	3000	640	1090	75	122	215	350	100	65	185	155	37.5	440	430	13.4	
24	240 125	360	120 - 264	3000	700	1190	108	190	167	285	180	110	220	205	87	780	760	26.5	

1) W_{tot} only valid for standard nominal torque M_2 ; with $M > M_2$ W_{tot} gets smaller; with $M < M_2$ W_{tot} gets larger

2) Basic brake with adapter box

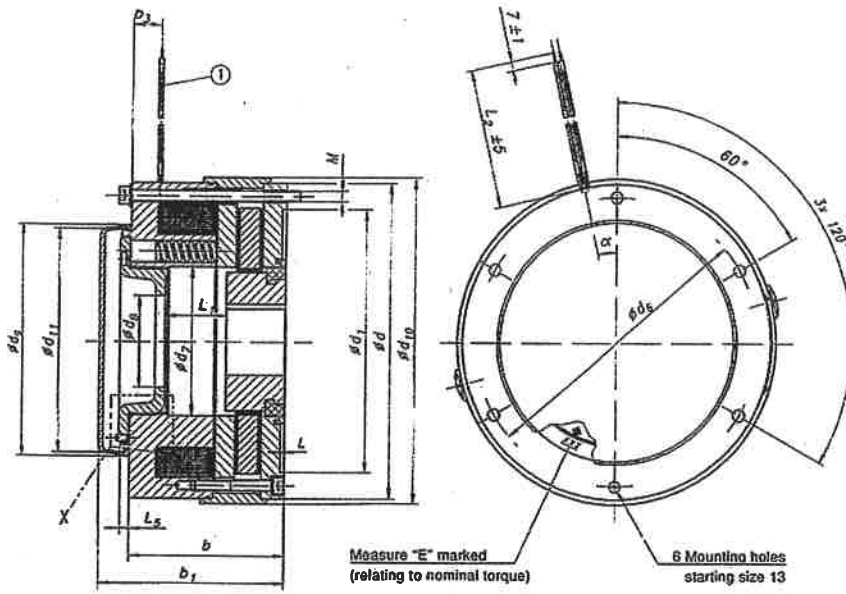

Cutout "X"

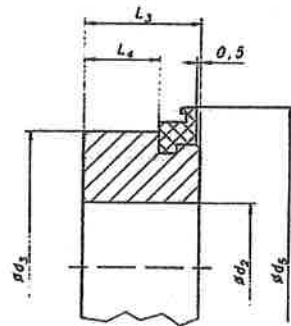
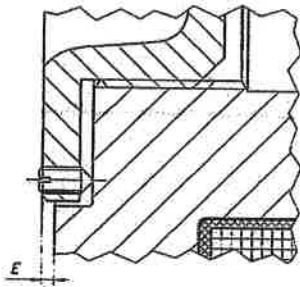

Hub

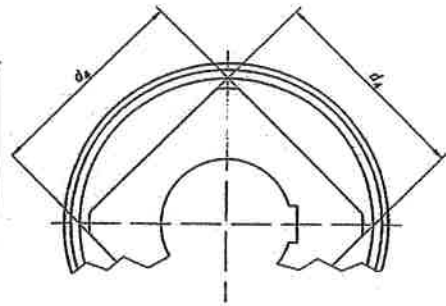

Direction of release
Angle of release γ

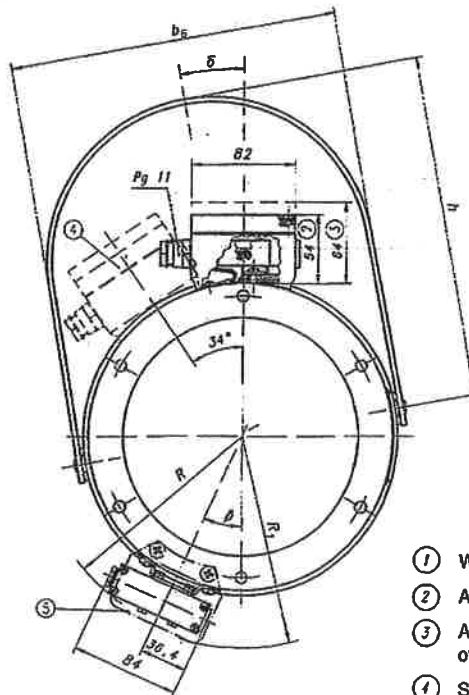
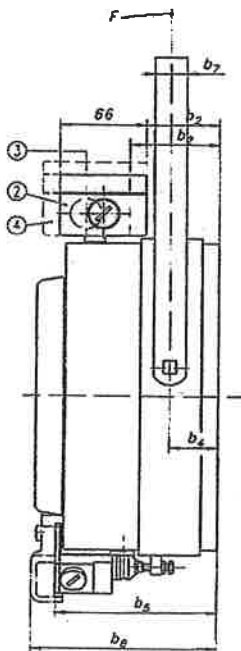

- ① With litz wires
- ② Adapter box with low lid (standard)
- ③ Adapter box with high lid only with over-excitation rectifier
- ④ Size 10
- ⑤ Protective lid

Dimensions (mm):

Sz.	d	d1 (H9)	d2 (H7) min / max	d3	d4	d5	d6	d7	d8	d9 ca.	d10	d11 (j7) Centr.-Ø	b	b1 ca.	b2	b3	b4	b5	b6
10	100	75	10 / 22	39	30	48.9	88	39.8	30	74	105	70	50	66	13	8	18.9	-	125.5
11	115	90	12 / 22	39	30	48.9	100	39.8	30	76	120	72	58.5	74.5	8.5	8.5	18.4	-	140.5
13	135	110	16 / 38	59	45	76	120	65.8	54	99	140	93	72.5	88.5	22.5	9	22.2	101	162.5
16	165	140	20 / 45	68	52	88	150	79.2	67	129	175	125	87.8	106	38.5	9	22.7	106	198
19	190	160	25 / 55	82	62	107	170	92.2	79	152	200	148	98.5	116	48.5	9.5	25.5	108	223
24	240	200	30 / 70	109	80	124.5	220	113	90	176	248	170	117.5	140.5	57.5	21	34	123	272.5

Sz.	b7	b8	h	L	L1	L2 Standard	L3	L4	L5	M	R	R1	E _{max}	E _{min}	α	β	γ°	δ	F (N)
10	16	-	118	2.5	14	100	20.5	13.5	5	3 x M5	-	-	3.3	2	15°	-	20°	180°	4
11	20	-	146	2.5	22.5	100	20.5	13.5	5	3 x M5	-	-	6.2	3.6	15°	-	20°	0°	7
13	20	-	161	2.5	31	100	24	15	5	6 x M5	111	-	4.7	3	15°	15°	20°	10°	20
16	20	113.5	209	2.5	39.5	100	26.5	17.5	5	6 x M6	125	130	8.6	4.7	15°	28.5°	18°	10°	60
19	20	123.5	224	3	47	100	30	20.5	5	6 x M6	137	142	11	4.5	15°	25°	19°	10°	72
24	25	142.5	269	3	48	100	45	30	7	6 x M8	161	165	5.6	2.7	7°	25°	17°	15°	110

The hub bore d2_{min} is mated - for reasons of sturdiness - to the torque and to the use of shaft material having a

tenacity of 500 N/mm². The hub can be delivered with smaller bore for special applications.

Normal keyway according to DIN 6885, Sheet 1, tolerance field JS 9, supporting on entire length.

Ordering Example

Spring-applied single-disc brake

77 600 A W / / Nm / mm

Size according to chart

Model

- 00 = Work brake (standard)
- 15 = No-work brake

Standard supply voltage

DC: 24, 102, 178 V

AC: 230, 400 V (only possible

for connections defined under 4 and 5)

Connections

- 1 = With fitz wire, length 100 mm (standard)
- 2 = With fitz wire, length 750 mm
- 3 = Adapter box with clamp
- 4 = Adapter box with rectifier
- 5 = Adapter box with over-excitation rectifier, with high lid

0 = Without microswitch

1 = With microswitch (starting size 13)

2 = With microswitch and protective lid (starting size 16)

Range of nominal torque [Nm]

Standard [Nm]

Sz.10: M₂ = 4 - 9

8

Sz.11: M₂ = 7 - 15.5

14

Sz.13: M₂ = 16 - 35.5

32

Sz.16: M₂ = 30 - 65

60

Sz.19: M₂ = 65 - 143

130

Sz.24: M₂ = 120 - 264

240

Smaller bore of adjustment ring as d8 (in mm steps)

Any values other than "standard" at extra cost

Ordering Example

Hub 1)

76 141 00900 / H7/

Size according to chart 2)

D for sizes 11 ... 16

A for sizes 19 and 24

0 = With seal

1 = Without seal

Bore diameter d₂ (H7) in mm (standard)

Sz. 10: Ø 15, Ø 18, Ø 20

Sz. 11: Ø 15, Ø 18, Ø 20, Ø 22

Sz. 13: Ø 20, Ø 25, Ø 30

Sz. 16: Ø 24, Ø 25, Ø 30, Ø 40

Sz. 19: Ø 30, Ø 40, Ø 45

Sz. 24: Ø 40, Ø 42, Ø 45, Ø 50

Effective bores with groove as per DIN 6885, Sheet 1, JS9

or primary bore = GB

1) Friction disc of sizes 10 ... 16 and / or hub of sizes 19 and 24

always with rubber bolts

2) Size 10 and 11 identical, please order size 11

Accessories

Size	Hand release	Fixing bolts Screw size	Order no.	Number per brake
10	76 14110B00940	DIN 912 - M5 x 60 - 8.8	304 028	3
11	76 14111B00940	DIN 912 - M5 x 70 - 8.8	304 030	3
13	76 14113B00940	DIN 912 - M5 x 85 - 8.8	304 035	6
16	76 14116B00940	DIN 912 - M6 x 100 - 8.8	304 060	6
19	76 14119B00940	DIN 912 - M6 x 110 - 8.8	304 061	6
24	76 14124B00940	DIN 912 - M8 x 130 - 8.8	304 088	6

Operating Instructions

with list of piece parts
 for spring-applied single-disc brake
 for D.C. operation

77 600 .. A00

77 600 .. A15

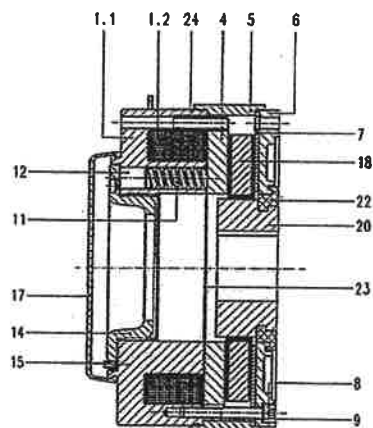

Illustration 1

- | | |
|------------------------|------------------------|
| 1.1 Magnet casing | 12 Setbolt |
| 1.2 Excitation winding | 14 Adjustment ring |
| 4 Armature | 15 Setscrew |
| 5 Intermediate ring | 17 Covering |
| 6 Flange | 18 Friction lining |
| 7 Disc | 20 Hub |
| 8 Cheese-head screw | 22 Seal |
| 9 Seal | 23 Antistadhesive disc |
| 11 Pressure spring | 24 Sleeve |
- (only for size 24)

Construction and Operating Principle

The magnet casing (1.1) of the spring-applied brake comprises the permanently fitted excitation winding (1.2) and is connected with the intermediate ring (5) and the flange (6) to the disc (7) by means of 3 screws (8), i.e. by means of 6 for size 24. The springs (11) press the friction lining (18), provided with a square bore and guided on the hub (20), via the armature (4) against the flange (6). This produces the braking effect. As soon as the excitation winding (1.2) is energised, the magnet casing (1.1) attracts the armature (4) against the force of the pressure springs (11). The friction lining (18) is released and the braking effect relaxed. As the spring-applied brake is a closed system, no forces will be exerted externally in the axial direction. The brake is protected against dust and water by the covering (17) and the seal (22).

Assembly

The spring-applied brake is delivered, ready for fitting. It needs not be dismantled for mounting. The friction lining (18) with its square bore is kept in position by the force of the springs (11) and is positioned to allow an easy insertion of the hub (20). In order to prevent the friction lining (18) from slipping out of this position, only energise the excitation winding (1.2) of the brake if the hub (20) is inserted.

Measure the air gap: Please refer to "Maintenance".

Slip the hub (20) onto the shaft already prepared and equipped with a feather key as per DIN 6885, Sheet 1, and secure axially (by means of a shaft shoulder, circlip or similar). Take care that the outside front surface of the flange (6) are on one level. The brake itself is screwed onto a motor flange or on a casing wall. Take care not to exceed the values indicated on chart 1 for the cheese-head screws (8) when tightening them. As extremely long screws as per DIN 912 are needed and these are not always available everywhere, they may be supplied together with the brake, if ordered.

For brakes with increased protection against corrosion or increased type of protection that are operated outside, place seals (e.g. Usit-seals) under the heads of the fixing bolts. Furthermore, seal the resting surface of the brake using a luting agent. The brake is centered on the neck of a motor flange or on a casing wall. However, do not hammer the brake with hard blows onto the centering shoulder, or else the parts made of magnetic soft iron will be damaged; rather provide a tolerance allowing the brake to be slipped on easily. We recommend to use h9 or e9 as tolerance for the centering shoulder (tolerance of the centering turned groove on flange (6) of brake H9). Allowed variation in exact centering with regard to shaft and thus to the hub is 0.2 mm at the most. The maximum allowed eccentricity is of the shaft of 0.05 mm.

A dislocation of the axial position of the hub caused by tolerances in serial production of, for example, the motor end shield and shaft should only have an effect towards the inside of the brake; or else, the function of the seal (22) will be impaired. For allowed tolerance, please refer to chart 1 (end play). For brakes with mechanical hand release, remove the hand release lever during operation; this will prevent the release lever from disturbing the exact braking due to its own weight or due to the accelerations it underlies when the brake is applied. If you do not want to remove the lever, place it so that it hangs down without encumbrance when the brake is applied.

Setting of Torque

The brake, when delivered, is set to standard nominal torque as per Technical Information Sheet or as ordered (100 %, please refer to diagram). Refer to the nameplate for the nominal torque M_2 set at the factory. The pre-set nominal torque of the brake is marked by the measure E = clearance of adjustment ring (14) (please refer to cutout "X" on Technical Information Sheet) next to the setscrew (15) on the collar. After untightening the setscrew (15), which is used to secure, it is possible to turn the adjustment ring (14) by using a pin spanner. Refer to the diagram to adjust the nominal torque to a new value. Please take care not to exceed the maximum and minimum clearance of the adjustment ring (refer to measure "E").

Chart 1

Brake size		10	11	13	16	19	24
Cheese-head screw with hexagon socket	DIN 912 8.8	M 5 x 60	M 5 x 70	M 5 x 85	M 6 x 100	M 6 x 110	M 8 x 130
Tightness of cheese-head screw	Nm	5.4	5.4	5.4	9.5	9.5	22
New value of air gap s	mm	Type A00 0.25 +0.2 0.28 +0.2	Type A00 0.25 +0.2 0.28 +0.2	Type A00 0.3 +0.2 0.33 +0.2	Type A00 0.3 +0.2 0.35 +0.2	Type A00 0.3 +0.2 0.4 +0.2	Type A00 0.35 +0.25 0.4 +0.25
Max. air gap s_{max}	mm	Type A00 0.65 0.65	Type A00 0.65 0.75	Type A00 0.75 0.85	Type A00 0.85 0.95	Type A00 0.85 1.05	Type A00 0.95 1.1
Max. adm. end play of hub	mm	0.8	0.8	1.0	1.0	1.0	1.2

Nominal torque $M_2 = f$ (clearance of adjustment ring E)
77 600 .. A00

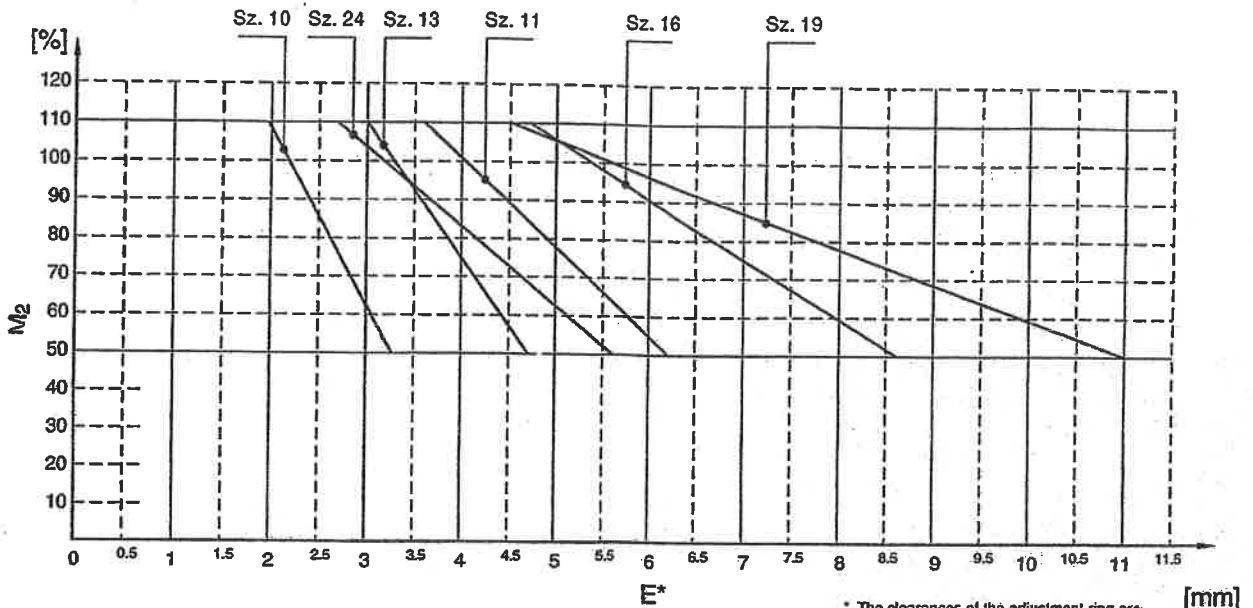

* The clearances of the adjustment ring are reference values and may stray by $\pm 15\%$ (for size 10 and 11 by $\pm 20\%$)

Microswitch

When releasing the brake (excitation winding energised), the control circuit is closed via the contacts (NO) and (C) (illustration 2).

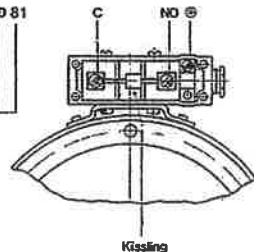
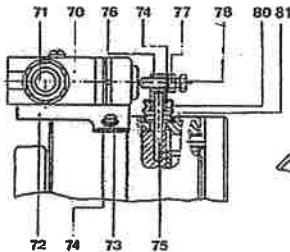

- 70 Microswitch
- 71 Packing bolt
- 72 Clip
- 73 Cheese-head screw
- 74 Crown gear
- 75 Spiral pin
- 76 Bolt
- 77 Hexagon nut
- 78 Hexagon screw
- 80 Bellows
- 81 Intermediate ring

Illustration 2 Brake with microswitch
Spare switch: Kistling ES V 500 - 903
IP 65

O (Common) = common contact
NO (Normally open) = make contact

Adjustment of Microswitch

Release brake electrically, loosen fixing nut (77), turn hexagon screw (78) clockwise until microswitch switches (you can hear a soft clicking or see the lamps turning on above NO [Normally open] and C [Common]). Should the switch be ON, turn it counter-clockwise into the OFF position. From the changeover position, continue turning the hexagon screw (78) as follows:
for brake size 13 by 50°
for brakes size 16 - 24 by 70° .
Then tighten fixing nut (77) again. Take care that the screw (78) is well locked after tightening. Check the function of the microswitch by turning it on and off.

Switching of the microswitch within the control circuit

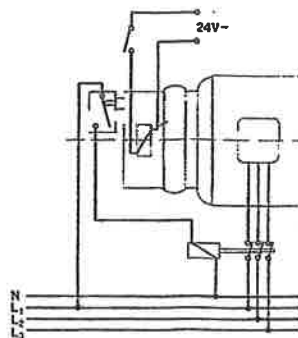

Centering Shoulder for Attachment of Tachometer

The centering diameter d_{11} is aligned, at the factory, with regard to the brake flange diameter d_1 , with a concentric running tolerance of max. 0.2 mm. The adjustment ring bore has a serial diameter of $\varnothing d_8$.

Rectifier Connections

The spring-applied brakes with integrated silicon rectifier may be switched as follows, depending on the coupling time needed:

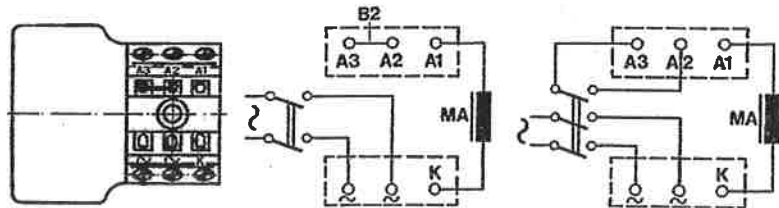

Illustration 3

Circuit I

Circuit II

a) Silicon rectifier in one-way circuit Illustration 3

Circuit I for normal coupling time: Operation is effected as per circuit diagram under A.C. and the brake (MA) is connected to the clamps K and A1. The bridge B2 between A2 and A3 is not to be removed.

Circuit II for reduced coupling time: The brake operates under A.C. and D.C. and is connected to the clamps K and A1. The bridge B2 is removed.

b) Silicon rectifier with over-excitation Illustration 4

This rectifier allows to reduce the disconnection time t_2 of the brakes down to approx. 40 % of the listed value. It consists of a rectifier in bridged circuit with thyristor and timer.

After the over-excitation time has elapsed, the bridge rectifier is switched to one-way rectification and thus the direct current to 102 V (with 230 V 1~) or 178 V (with 400 V 1~).

The over-excitation time may be chosen between 0.12 and 1.76 seconds by exchanging the resistor R as per the following formula:

$$R \approx \frac{t_0 \cdot 150 \text{ k}\Omega \text{ s} - 16.5 \text{ k}\Omega \text{ s}}{1.76 \text{ s} - t_0}$$

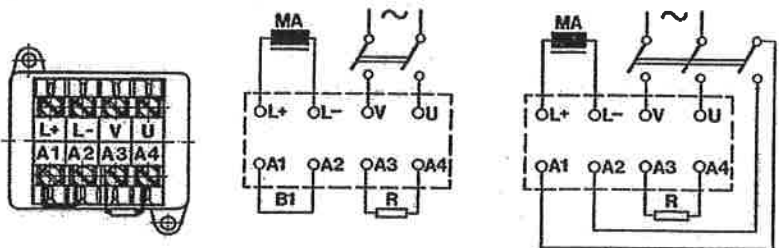

Illustration 4

Circuit I

Circuit II

Circuit I for normal coupling time: The brake operates only under A.C., and is connected to the clamps L+ and L-. The clamps A1 and A2 are bridged with bridge B1.

Circuit II for reduced coupling time: The brake operates under A.C. and D.C. and is connected to the clamps L+ and L-. The bridge B1 is to be removed.

Dismantling the Brake and Replacement of Spare Parts

(Reference numbers according to illustration 1 and 5)

When dismantling the brake, proceed as follows: Remove the covering (17), loosen setscrew (15), twist out the adjustment ring (14) as well as the cheese-head screws (8). Due to the protective sealing between flange (6) and intermediate ring (5) on one side and between the magnet casing (1.1) and the intermediate ring (5) on the other side, it

might be necessary to slightly twist the parts against each other to separate them. After dismantling and prior to assembling them again, clean all piece parts - except for the friction lining (18) - in a commercially available cleansing agent. Slightly lubricate the thread of the adjustment ring (14), setbolts (12), and pressure springs (11). Remove any residues of the luting agent on the centering diameter of the intermediate ring (5), flange (6), disc (7), antiadhesive disc (23), and magnet casing (1.1). In case

of vertical axial centre, renew the luting agent (such as "Feuchtigkeitsschutzlack" 190 (lacquer protecting against humidity) of the supplier Dr. Beck, Hamburg) first on the centering of the intermediate ring (5), which is facing the magnet casing (1.1), then connect to magnet casing, and, after a short drying interval, proceed as per the instructions of the luting agent supplier while mounting the flange (6) in the prescribed way. The convex side of the disc (7) must rest on flange (6) (no disc with size 19 and 24).

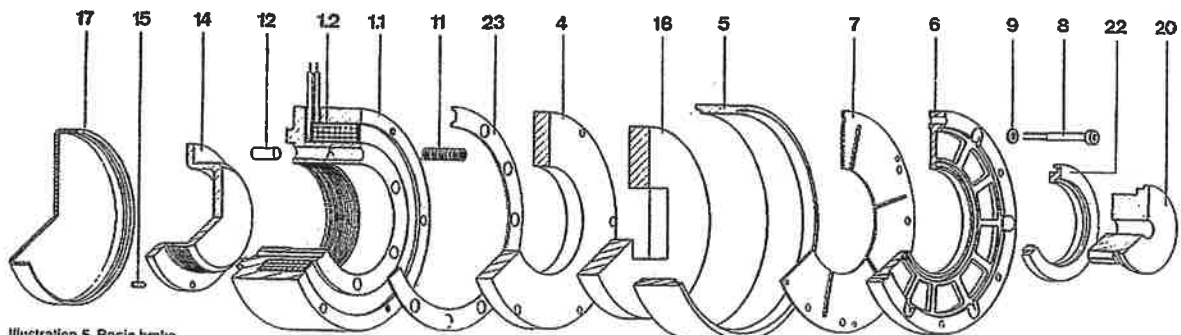

Illustration 5 Basic brake

- | | | | |
|------------------------|---------------------|--------------------|----------------------|
| 1.1 Magnet casing | 7 Disc | 12 Setbolt | 18 Friction lining |
| 1.2 Excitation winding | 8 Cheese-head screw | 14 Adjustment ring | 20 Hub |
| 4 Armature | 9 Seal | 15 Setscrew | 22 Seal |
| 5 Intermediate ring | 11 Pressure spring | 17 Covering | 23 Antiadhesive disc |

When twisting the adjustment ring (14) back into place, please observe the extent by which the ring overlaps the collar (marked on collar). The setscrew (15) must now be adjacent to the number on the magnet casing (1.1). This is the only way of getting back to the pre-set torque. But the setscrew (15) may not rest on a setbolt (12). This may be checked by removing the setscrew. When using the brake with a tachometer attachment, re-align the concentricity (please refer to centering shoulder for tachometer attachment).

Spare parts that you might need can be taken from the illustration 5 and ordered by defining type and number of the spring-applied brake.

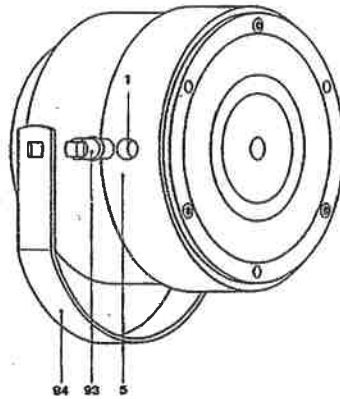

Illustration 6 Hand release

- 1 Bore for measuring air gap (remove cams and/or plug)
- 5 Intermediate ring
- 93 Cams with accessories
- 94 Lever

Maintenance

Maintenance of the brake, except for checking the air gap, is not necessary. The air gap, however, may only be measured if the brake is energised. To this effect, stick a thickness gauge through a bore in the intermediate ring (5) between armature (4) and friction lining (18). As soon as the maximum air gap has been reached (values \approx M₂-standard), replace the friction lining (18). This becomes necessary because the distance between armature (4) and magnet casing (1.1) has been reduced to such an extent due to the wear of the friction disc that the magnetic force is no longer strong enough to release the brake. Please refer to chart 1 for the observance of the tightness of the fixing bolts.

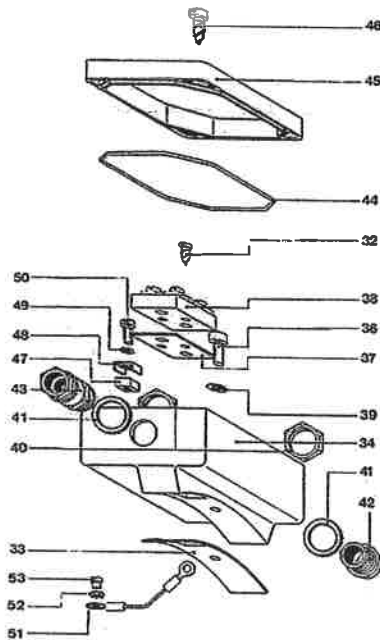

Illustration 7 Adapter box

- 32 Pan head tapping screw
- 33 Seal
- 34 Box
- 36 Cheese-head screw
- 37 Spacer
- 38 Connection
- 39 Washer
- 40 Hexagon nut
- 41 Sealing washer
- 42 Screw plug
- 43 Packing bolt
- 44 Lubricating cord
- 45 Lid
- 46 Pan head tapping screw
- 47 Plate
- 48 Clamping clip
- 49 Split washer
- 50 Cheese-head screw
- 51 Line
- 52 Crown gear
- 53 Cheese-head screw

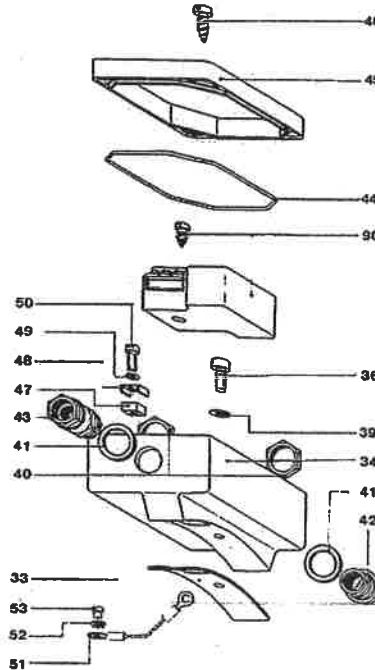

Illustration 8 Adapter box with silicon rectifier

- 33 Seal
- 34 Box
- 36 Cheese-head screw
- 39 Washer
- 40 Hexagon nut
- 41 Sealing washer
- 42 Screw plug
- 43 Packing bolt
- 44 Lubricating cord
- 45 Lid
- 46 Pan head tapping screw
- 47 Plate
- 48 Clamping clip
- 49 Split washer
- 50 Cheese-head screw
- 51 Line
- 52 Crown gear
- 53 Cheese-head screw
- 90 Rectifier unit

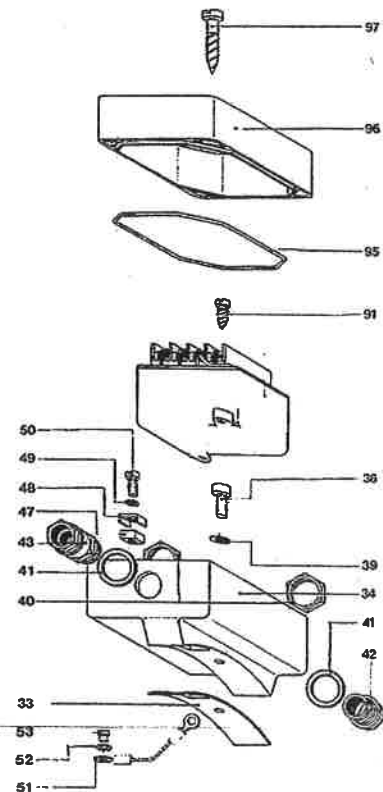

Illustration 9 Adapter box with rectifier with over-excitation

- 33 Seal
- 34 Box
- 36 Cheese-head screw
- 39 Washer
- 40 Hexagon nut
- 41 Sealing washer
- 42 Screw plug
- 43 Packing bolt
- 47 Plate
- 48 Clamping clip
- 49 Split washer
- 50 Cheese-head screw
- 51 Line
- 52 Crown gear
- 53 Cheese-head screw
- 91 Rectifier unit
- 95 Lubricating cord
- 96 Lid
- 97 Pan head tapping screw

POWERMITE

METSO SALSTACK PROJECT - POWERMITE COM 1348 CRD OPERATED ROTARY CONNECTIONS FOR FIBRE OPTIC DIGITAL OR ANALOGUE SIGNAL TRANSMISSION

OPTICAL FIBRE ELEMENT (OFE) ROTARY CONNECTOR

Future-orientated solution for data transmission to movable consumers in lifting and conveying systems.

Following the successful introduction of optic-fibre cable into the telecommunication sector, they are now finding increasingly widespread acceptance in industry.

This success is due to the excellent transmission characteristics for large data volumes. The transmission of digital data, control commands, voice and analogue video signals over great distances is possible without any interference. There is no impairment to the quality by electromagnetic interference or other influences of different networks.

Optic-fibre cables are therefore recommended for data communication to movable consumers, which are supplied with electrical energy via trailing cables. The technical pre-requisites are given by low and medium voltage trailing cables in which the optic-fibre elements are contained. See Powermite Cable Catalogue page 44.

In order to reach the control panel, switchgear or the monitoring cameras of the movable machines, the data optical fibres must be routed to the cable reeling drums slipping compartment in which the rotary connector is housed.

Technical data:

Effective available revolutions:

Types OFE40, OFE 80, OFE120 (each rotary connector has a rev-counter fitted to show the state of revolutions used up of the total capacity).

IMPORTANT NOTE:

When the cable or CRD is maintained and the Reel is operated in the process, the rotary connector has to be disengaged from the drive shaft! Only when the position over the centre feed is reached by the machine must the rotary connector be coupled back and set to the mode to ensure that the rotary connector **is not over rotated** beyond its max. turns!!

Fibre type: Graded-index optical fibre type 50/125 or 62,5/125 μm (multimode). Single-mode optical fibres are available on request.

Fibre count: 2 to 12 individual fibres. The standard type contains 6 fibres.

Fibre Connection: Will be via connectors in the fixed or rotating patch panel.

Available Plug: F-SMA 905, FC/PC, ST being standard

Connectors: Further connector types are available on request.

Ambient temperature: -25 : +60° C

Design: Heavy-duty, rugged type, suitable for use under hardy conditions, e.g. strong vibrations on excavators in open-pit mining, due to its technically uncomplicated design.

Maintenance: The system operates maintenance-free

Dimming: As this is an uninterrupted transmission, only the intrinsic damping of the used fibre occurs. With a fibre length of about 8m in the rotary connector, fibre damping can be disregarded.

For the rotary connector, including bilateral connections, a damping of less than 3 dB is to be taken into account.

Transmission options:

- V24, V11, RS 232 serial interfaces
- RS 422 and 20 mA
- Digital transmission systems with transmission rates of 20 kbit/s to 50 Mbit/s
- Video transmission systems
- Audio transmission systems
- Networks

POWERMITE

AFRICA (PTY)LTD

POWERMITE HOUSE
92 MAIN REEF ROAD
TECHNIKON
1724 ROODEPOORT
P O BOX 7745
JOHANNESBURG 2000

TELEPHONE : (011) 271-0000
TELEFAX : (011) 760-3099
EMAIL : powermite.jhb@global.co.za
INTERNET : <http://www.powermite.co.za>

DRAWN

MRA/mvds

APPROVED

DATE

10.03.03

SHEET NO.

1 OF 3

SCALE N.T.S.

REV. DATE

DRG. NO. RG00.T.014 REV.01

THIS DRAWING IS THE PROPERTY OF POWERMITE AFRICA (PTY)LTD AND IS SUBJECT TO RECALL AND MUST NOT BE REPRODUCED OR ITS CONTENTS DIVULGED WITHOUT WRITTEN PERMISSION

POWERMITE

METSO SALSTACK PROJECT - POWERMITE COM 1348
**CRD OPERATED ROTARY CONNECTIONS FOR FIBRE
 OPTIC DIGITAL OR ANALOGUE SIGNAL
 TRANSMISSION**

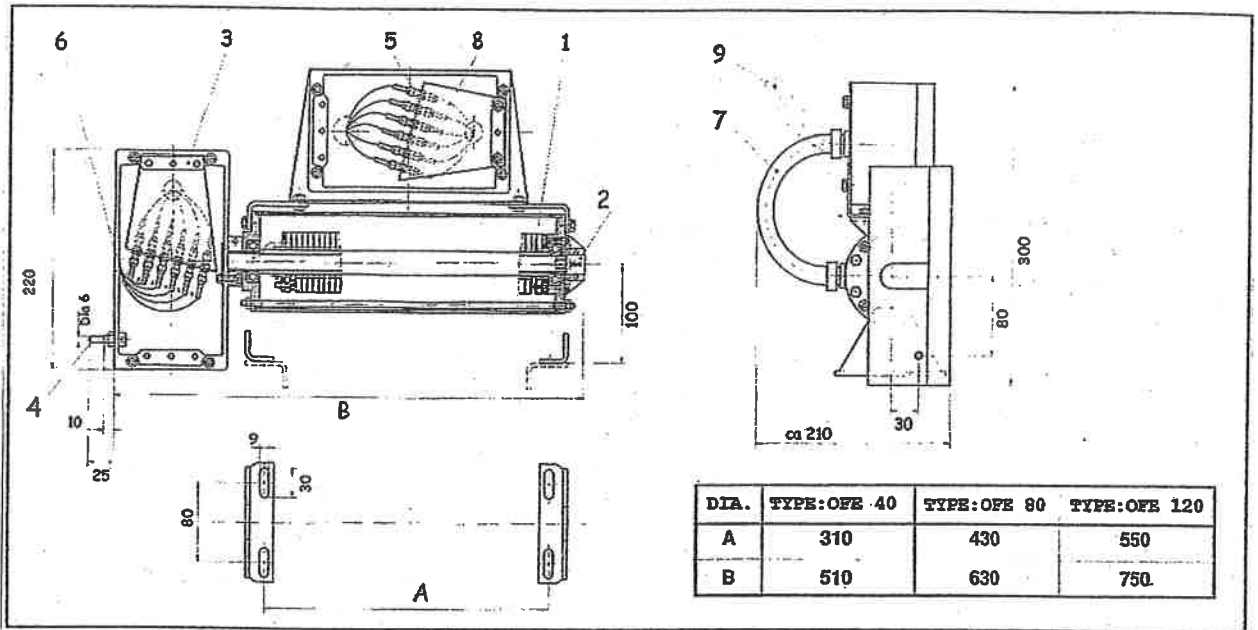

Explanation to above Drawing (see also pictures on page 3 of 3)

- 1- Optic-fibre (OFE) rotary connector
- 2- Display for the number of effective rotations (see **important** comment on page 1 of 3 under - Technical Data
- 3- Rotating patch panel fitted to the rotary connector
- 4- Towing pin of the rotating patch panel
- 5- Optic fibre termination which joins the stationary patch panel to the OFE spiral
- 6- Optic fibre link from the rotating patch panel to OFE spiral
- 7- Optic fibre link from the rotary connector to the stationary patch panel
- 8- Stationary patch panel, cable gland PG 13,5
- 9- Optic fibre link to stationary remote patch panel

OFE	40	12	G1	2	Type Key Optic-fibre (OFE) rotary connector
					Connector version: 1 = Type F-SMA 2 = Type ST 3 = Type FC/PC
					Fibre Types: G1 = multi mode application optical fibre 50/125 µm G2 = multi mode application optical fibre 62,5/125µm G3 = Single mode application E9/125µm
					Number of fibres : 2 - 12
					Choice effective
					Revolutions : 40 / 80 / 120
					Optic fibre (OFE)
					Rotary connector :

POWERMITE

AFRICA (PTY)LTD

POWERMITE HOUSE
 92 MAIN REEF ROAD
 TECHNIKON
 1724 ROODEPOORT
 P O BOX 7745
 JOHANNESBURG 2000

TELEPHONE : (011) 271-0000
 TELEFAX : (011) 780-3099
 EMAIL : powermite.jhb@global.co.za
 INTERNET : http://www.powermite.co.za

DRAWN MRA/mvds	APPROVED 	DATE 10.3.03	SHEET NO. 2 OF 3
-------------------	--------------	-----------------	---------------------

SCALE N.T.S.	REV. DATE	DRG. NO. RG00.T.014	REV. 01
--------------	-----------	---------------------	---------

THIS DRAWING IS THE PROPERTY OF POWERMITE AFRICA (PTY)LTD AND IS SUBJECT TO RECALL AND MUST NOT BE REPRODUCED OR ITS CONTENTS DIVULGED WITHOUT WRITTEN PERMISSION

POWERMITE

**CRD OPERATED ROTARY CONNECTIONS
FOR FIBRE OPTIC DIGITAL OR ANALOGUE
SIGNAL TRANSMISSION**

METSO SALSTACK PROJECT - POWERMITE COM 1348

OPTIC - FIBRE ROTARY CONNECTOR

SEE DRAWING ON PAGE 2 of 3

ITEMS 1 - 9

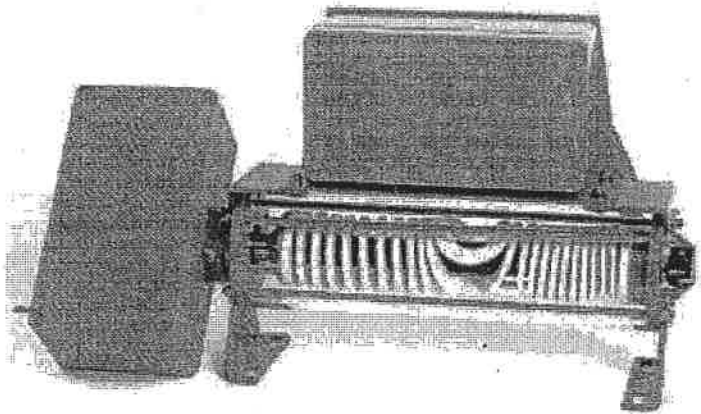

PICTURE 1

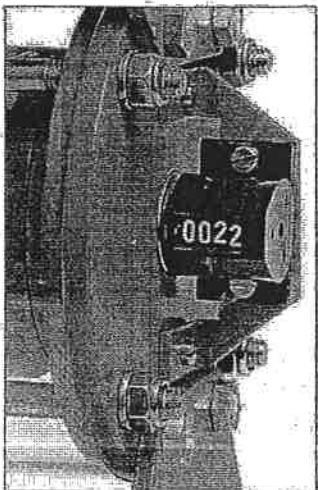

PICTURE 2

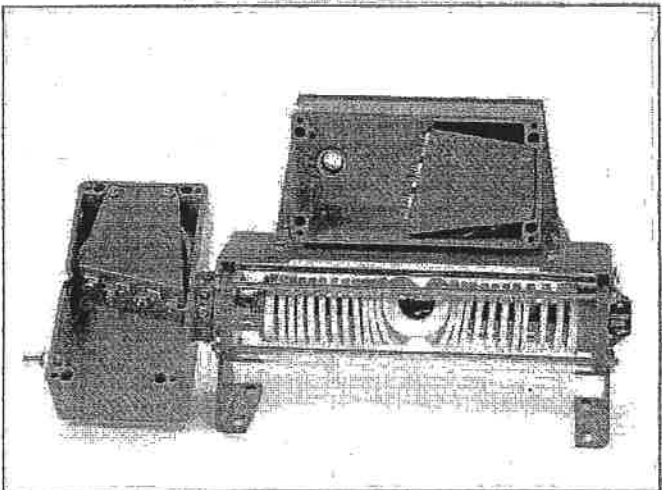

PICTURE 3

POWERMITE

AFRICA (PTY)LTD

**POWERMITE HOUSE
92 MAIN REEF ROAD
TECHNIKON
1724 ROODEPOORT
P O BOX 7745
JOHANNESBURG 2000**

**TELEPHONE : (011) 271-0000
TELEFAX : (011) 760-3099
EMAIL : powermite.jhb@global.co.za
INTERNET : http://www.powermite.co.za**

DRAWN MRA/mvds	APPROVED 	DATE 10.3.03	SHEET NO. 3 OF 3
SCALE N.T.S.	REV. DATE	DRG. NO. RG00.T.014 REV. 01	

THIS DRAWING IS THE PROPERTY OF POWERMITE AFRICA (PTY)LTD AND IS SUBJECT TO RECALL AND MUST NOT BE REPRODUCED OR ITS CONTENTS DIVULGED WITHOUT WRITTEN PERMISSION

POWERMITE[®] Over tension / Under tension Limit Switches

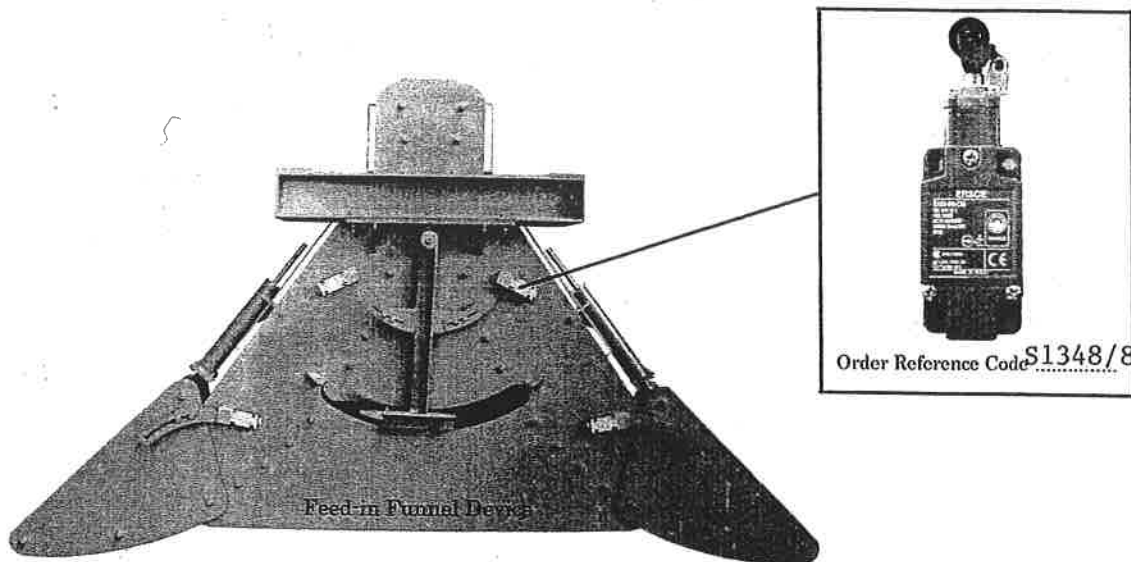

Technical Data – Roller Limit Switch (See Item 15.1.9 in Manual)

Switch Type	:	E400C
Contact Data	:	1 - NC > 10A, 500V AC 1 - NO
Operation Temperature:		- 25° C to + 80° C
Protection Class	:	IP65
Approval	:	VDE 0113 IEC 947/5/1

POWERMITE

LIMIT SWITCHES ON CABLE REELING DRUMS. PURPOSE, LOCATION AND CONTACT ARRANGEMENT

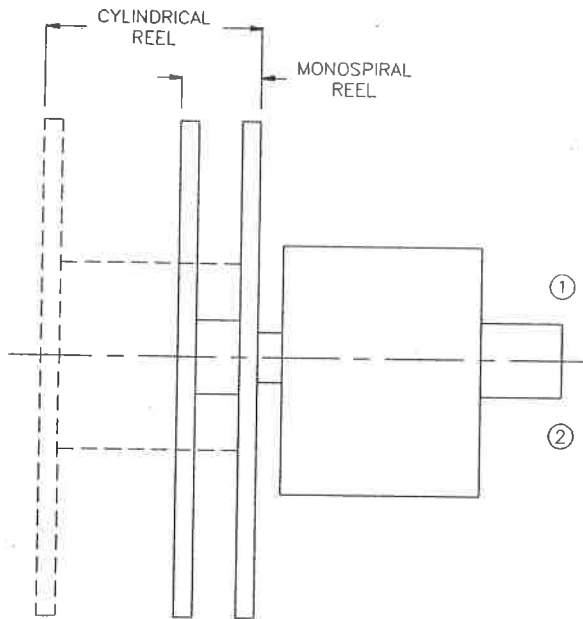

GEAR CAM LIMIT SWITCH

MAX. SETTINGS FOR FINAL LAYER

- 1) REEL FULL (SET TO MAX. CABLE PAYOUT)
- 2) REEL EMPTY (SET FOR 2 LAYERS TO REMAIN ON I.D. OF REEL)
- 3+4) SPARES

ALTERNATIVE ①

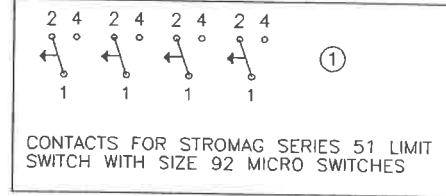

ALTERNATIVE ②

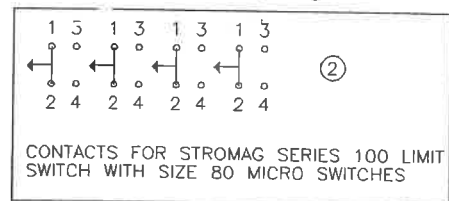

CABLE FUNNEL WITH OVER TENSION / SLACK CABLE LIMIT SWITCHES

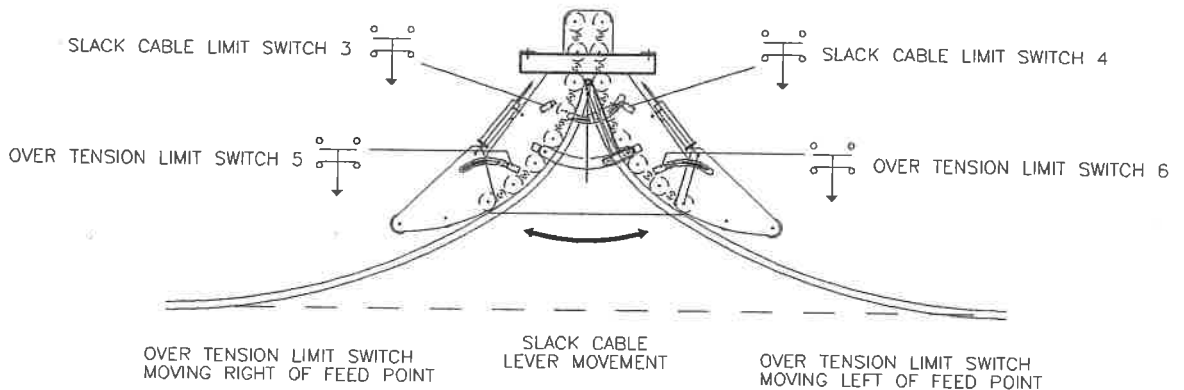

LIMIT SWITCH 5+6

SWITCHES 5+6 MUST BE SET TO SUIT THE TENSION LIMITS OF THE TRAILING CABLE i.e. AVOID OVERTENSION.

LIMIT SWITCH 3+4

SWITCHES 3+4, WILL DETECT SLACK CABLE AND IS OPERATED BY THE DEPICTED LEVER. THE LEVER MUST ALWAYS BE TO THE LEFT OR RIGHT OF THE CABLE FUNNEL, NEVER IN THE MIDDLE DURING OPERATION. WHEN PASSING THE CENTER FEED AREA SWITCHES 3+4 MUST BE BRIDGED (WITHIN CIRCUITRY OF OTHERS) DURING THIS TIME.

LIMIT SWITCH 1 OR 2

THE MACHINE MUST STOP IF LIMIT SWITCH 1 OR 2, IS ACTIVATED BECAUSE THE CABLE PAYOUT LIMITS HAVE BEEN REACHED. THESE SETTINGS SHOULD ALWAYS BE TESTED DURING SITE COMMISSIONING BY COMPETENT STAFF.

ALL LIMIT SWITCHES ABOVE, WHEN ACTIVATED, MUST STOP THE MOBILE MACHINERY TO AVOID DAMAGE TO CABLE AND/OR CABLE REEL. THE CABLE REEL MOTOR, HOWEVER, MUST REMAIN ENERGIZED AFTER A LIMIT SWITCH HAS STOPPED THE MOBILE MACHINE TRAVEL, TO ALLOW THE CABLE REEL TO PAYOUT AND/OR COLLECT AS MUCH CABLE NEEDED TO CATER FOR THE OVERRUN OF THE MACHINE DUE TO BRAKE SETTINGS.

POWERMITE

AFRICA (PTY)LTD

POWERMITE HOUSE
92 MAIN REEF ROAD
TECHNIKON
1724 ROODEPOORT
P O BOX 7745
JOHANNESBURG 2000

TELEPHONE : (011) 271-0000 (32 LINES)
TELEFAX : (011) 760-3099
EMAIL : powermite.jhb@global.co.za
INTERNET : http://www.powermite.co.za

DRAWN S.GOMERSALL	APPROVED 	DATE 21/08/01	SHEET NO. 1 OF 1
SCALE N.T.S.	REV. DATE	DRG. NO: RG00.T.010	REV. 01
THIS DRAWING IS THE PROPERTY OF POWERMITE AFRICA (PTY)LTD AND IS SUBJECT TO RECALL AND MUST NOT BE REPRODUCED OR ITS CONTENTS DIVULGED WITHOUT WRITTEN PERMISSION			



Powermite House
 92 Main Reef Rd P.O. Box 7745 Inter Code ++27
 Jhnicon Johannesburg Tel: (011) 271-0000
 Roodepoort 2000 Telefax (011) 760-3099
 1724 E-mail: powermite.jhb@global.co.za
 Website: http://www.powermite.co.za

**METSO SALSTACK PROJECT
POWERMITE COM 1348**

**Geared Limit Switches – Series 51
Nr./No. 143 51 0000–956**

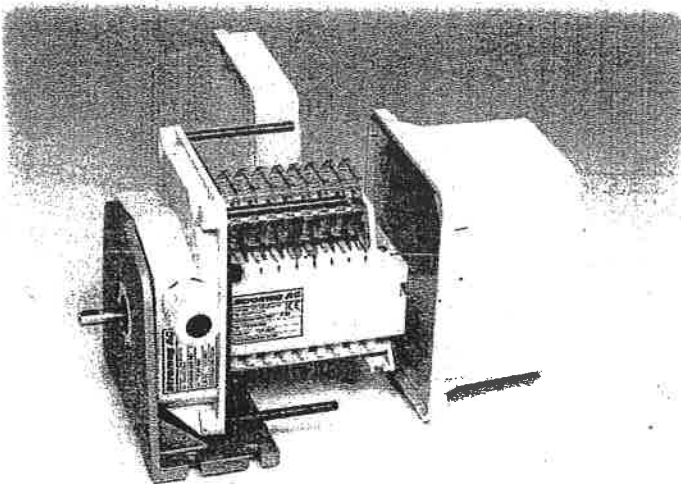

1. Technical data

1.1 Nameplate

The following data is indicated on the nameplate:

Limit switch series	51
Housing protection	IP..
Stromag Order–Ref.–No.
Limit switch type	see chapter 1.2 Type : 51/2B-29 BM492/B14
250 V a.c., 24 V d.c. – 6 A	

1.3 Technical data

The max. admissible speed as well as the other technical data for every limit switch type are indicated in the gear or contact table resp.: please refer to table 1 and table 2.

1.2 Key to type — EXAMPLE

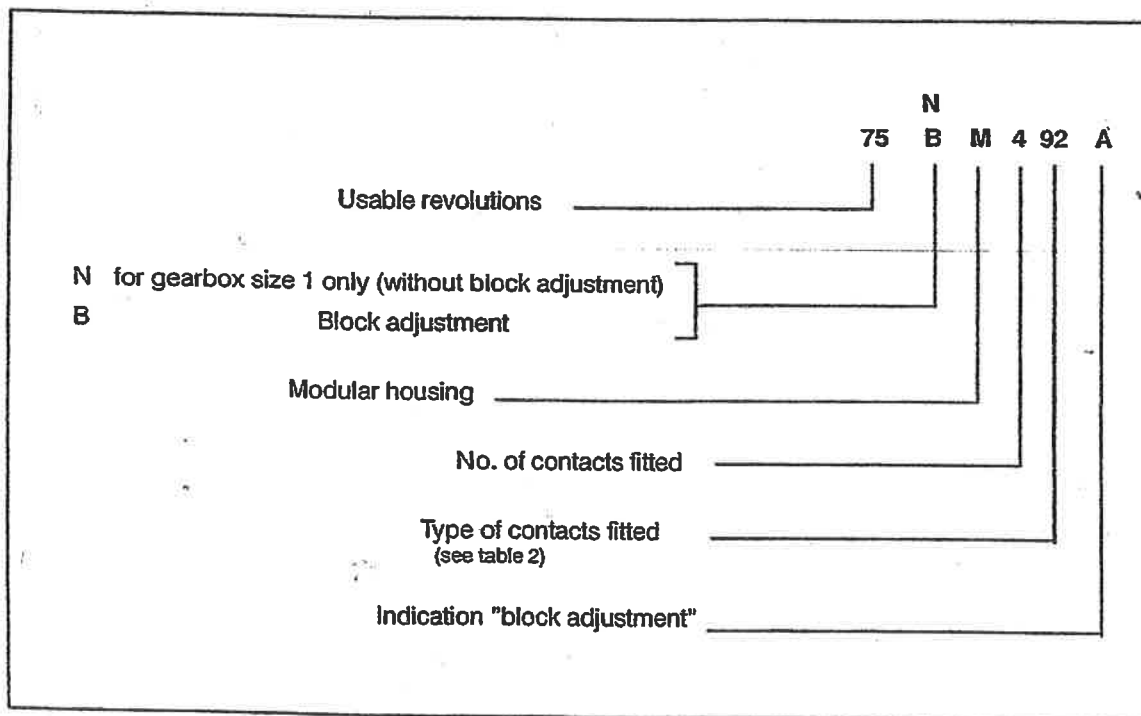

Powermite House
 02 Main Reef Rd
 chnicon
 Roodepoort
 1724

P.O. Box 7745
 Johannesburg
 2000

Inter Code ++27
 Tel: (011) 271-0000
 Telefax (011) 760-3099
 E-mail: powermite.jhb@global.co.za
 Website: http://www.powermite.co.za



**METSO SALSTACK PROJECT
 POWERMITE COM 1348**

**1.3 - Table 1
 Gear Data**

Gearbox Size	Usable revs. selected	Usable revs. theor.	Gear ratio i	Input/output stage i = 2,698 i = 1,653	No. of intern. stages of ratio i = 4,285	Overrun revs. of drive shaft in each direction	1 rev. of the drive shaft cor. resp. to an ang. motion of cam disc = °	Change-over contact reset rev. at driving shaft	Normally closed contact reset rev. at driving shaft	max. drive speed min ⁻¹	min. drive shaft for change over contact min ⁻¹
1	4,1	4,16	4,285	/.	1x 4,285	0,12	84,00	0,01	0,015	1000	0,35
	6,5	6,87	7,083	1,653	1x 4,285	0,20	50,80	0,02	0,025	1200	0,55
	11,0	11,22	11,560	2,698	1x 4,285	0,33	31,14	0,03	0,04	1500	0,90
2	17,5	17,82	18,361	/.	2x 4,285	0,54	19,60	0,05	0,06	1800	1,45
	29,0	29,46	30,350	1,653	2x 4,285	0,88	11,86	0,08	0,10	1800	2,35
	48,0	48,09	49,538	2,698	2x 4,285	1,44	7,27	0,13	0,17	1800	3,80
3	75,0	76,38	78,678	/.	3x 4,285	2,30	4,57	0,20	0,27	1800	6,10
	125,0	126,26	130,054	1,653	3x 4,285	3,79	2,77	0,34	0,45	1800	10,00
	205,0	206,08	212,272	2,698	3x 4,285	6,19	1,69	0,55	0,74	1800	16,35
4	323,0	327,30	337,135	/.	4x 4,285	9,80	1,06	0,88	1,18	1800	26,00
	540,0	541,03	557,284	1,653	4x 4,285	16,25	0,65	1,45	1,93	1800	43,00
	880,0	883,06	909,590	2,698	4x 4,285	26,53	0,40	2,36	3,18	1800	70,00
5	1380,0	1402,48	1444,620	/.	5x 4,285	42,14	0,25	3,76	5,05	1800	112,0
	2280,0	2318,92	2387,960	1,653	5x 4,285	69,66	0,15	6,21	8,35	1800	185,0
	3730,0	3783,96	3897,58	2,698	5x 4,285	113,68	0,09	10,14	13,63	1800	300,0

Cam adjustment: 1 revolution of the adjusting worm corresponds to 2.464° at the cam disc.



Powermite House
 Main Reef Rd
 Technicon
 Roodepoort
 1724

P.O. Box 7745
 Johannesburg
 2000

Inter Code ++27
 Tel: (011) 271-0000
 Telefax (011) 760-3099
 E-mail: powermite.jhb@global.co.za
 Website: http://www.powermite.co.za

**METSO SALSTACK PROJECT
 POWERMITE COM 1348**

1.3 - Table 2: Contact Data

Contact type	Switch actuation	Positive opening of normally closed contact	Switch rating				Mech. life in mio. switching operations	Opening width of the contact (VDE 0660) Part 206
			AC		DC			
			I _{th} A	U _i V	24V A 1)	80V A 1)		
Change-over switch 92 92 P 92 L	Snap action	YES	6 2)	250	6	2	10	1,2 mm
Normally closed contact 93 93 P 93 L	Snap action	YES	6 2)	250	6	2	10	3 mm
Change-over switch 30 P	Snap action	NO	0,1	250	3	1	10	<3 mm

1)-T = Oms 2) VDE 0660 T200-

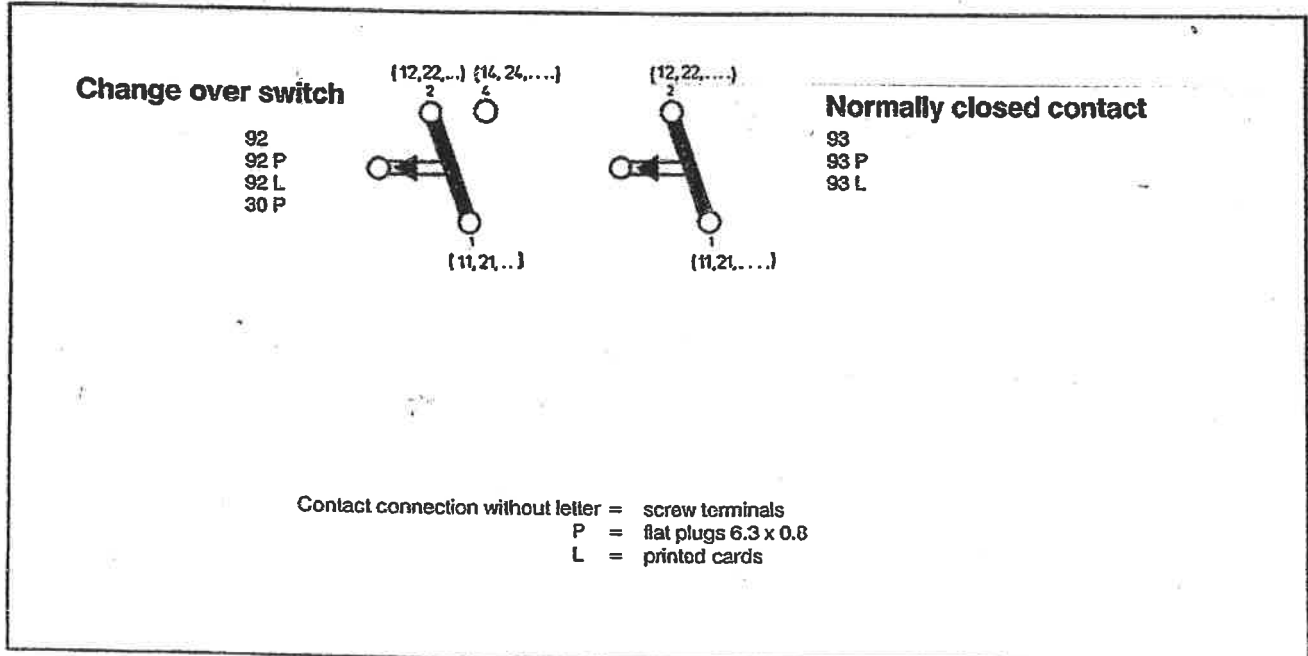

Powermite House

100 Main Reef Rd

Johannesburg

Roodepoort

1724

P.O. Box 7745

Johannesburg

2000

Inter Code ++27

Tel: (011) 271-0000

Telefax (011) 760-3099

E-mail: powermite.jhb@global.co.za

Website: <http://www.powermite.co.za>

POWERMITE®

**METSO SALSTACK PROJECT
POWERMITE COM 1348**

1.4 Contact connections

The contacts can either be connected through screw terminals for a cable cross section of 0.75 mm² to 1.5 mm² or through flat plugs 6.3 x 0.8 mm or through a printed card with cage tension spring terminals for a cross section of 0.14 to 2.5 mm². For contact 30, flat plugs only.

Connection of the cage tension spring terminals:
By inserting a screw driver knife – max. width 2.5 mm – into the slot located above the cable inlet hole, the cable terminal spring is opened for insertion of the bared cable end. Cable end 6 mm bared. Optionally unifilar up to fine-strand cables with or without end sleeves for strands can be connected. The contact No. 1 is always at the driving shaft side.

The cage tension spring terminal on or below the printed card is always designed for the change-over contacts (3 connections per contact). When using normally closed contacts (2 connections), the normally open terminal is not connected.

1.5 Application range and intended use



The geared limit switch has to be used in compliance with its type of protection as per chapter 7.2 and its switching capacity as per table 2.

The service conditions as per chapter 7.1 have to be adhered to.

The instructions for assembly and maintenance, given by the manufacturer, must be adhered to. When fitting limit switches with protection IP 00 or IP 20 in combination with main current contactors, particularly in small switch boxes, the ozone generated in the switching spark can enrich in the switch box.

Under certain conditions, ozone can affect the parts of synthetic material.

In case of such an arrangement, please consult our technical after-sales service

Failure to observe such instructions or any usage over and above the specified applications will be deemed to be improper use.

The manufacturer will not be liable for any damage caused by such actions and the user will bear sole responsibility in such cases.

Powermite House

100 Main Reef Rd

Technicon

Roodepoot

1724

P.O. Box 7745

Johannesburg

2000

Inter Code ++27

Tel: (011) 271-0000

Telefax (011) 760-3099

E-mail: powermite.jhb@global.co.za

Website: <http://www.powermite.co.za>

**METSO SALSTACK PROJECT
POWERMITE COM 1348**

2. Safety Guide Lines

2.1 Symbol for safety at work



This symbol denotes all the safety instructions in this manual which deal with danger to life and limb of personnel. These instructions must be adhered to and particular caution exercised in these cases. All users must be familiarised with the safety instructions.

2.2 Instructions **Caution!**

The term "caution" denotes those sections in this manual which require special attention, in order that the guidelines, recommendations and correct procedures are complied with to prevent damaging or destroying the limit switch.

2.3 Safety instructions for working

The following recommendations are of particular importance:

The limit switch has been manufactured to the highest up to date standard and is operationally safe. However, the product can become a risk to safety when used improperly by untrained personnel or for an application it is not designed for.

Every person involved in assembling, disassembling, commissioning, operating and maintaining (inspecting, servicing and repairing) the limit switch must be authorised, adequately trained and instructed. Each such person must have read and understood this instruction manual, especially in respect to the safety instructions.

We do not accept liability for damage or malfunctioning, resulting from non-adherence to this manual.

Any work process involving the limit switch which impairs safety is to be avoided.

The user is obliged to inform the supplier immediately of any change occurring to the limit switch which adversely affects safety.

The user is obliged to only operate the limit switch when it is functioning correctly.

Unauthorised changes and modifications which impair safety, as well as the use of non-authentic components is not permitted.

After electrical assembly or repair a full electrical safety check should be made (e.g. earth resistance).

Caution! In every case the local safety and accident prevention regulations are also applicable, the user must ensure that these are complied with.

We reserve the right to make modifications of a technical nature to this manual if required for limit switch development.

We recommend that these instructions are incorporated into the service manual of the user.

3. Transportation

3.1 Packing

The type of packing depends on the transportation route and the delivery extent. The symbols marked on the packing must be adhered to.

3.2 Pre-mounting condition

The geared limit switch is supplied completely mounted.

3.3 Sensitivity

Be particularly careful on transportation of the limit switch in order to avoid damage due to external force or careless loading and unloading. In relation to transportation type and time, corresponding transportation protection devices have to be provided. During transportation avoid shocks as well as the generation of condensation water due to temperature fluctuations.

3.4 In-process stocking

In case of in-process stocking as well as during transportation avoid the generation of condensation water by strong temperature fluctuations. Also avoid the generation of dust. Limit switches of protection IP 00 and IP 20 shall be stocked in their transportation package, if possible.

3.5 Delivery extent

On receipt check the consignment for completeness. Possible damage during transportation and/or missing parts must be advised immediately and in writing.

Powermite House
92 Main Reef Rd P.O. Box 7745 Inter Code ++27
Jhnicon Johannesburg Tel: (011) 271-0000
Roodepoort 2000 Telefax (011) 760-3099
1724 E-mail: powermite.jhb@global.co.za
Website: http://www.powermite.co.za

**METSO SALSTACK PROJECT
POWERMITE COM 1348**

4. Construction, functioning, constructional characteristics (see Fig.1)

The fitted maintenance-free planetary gears with or without spur gear pre-step down are made of thermoplastic plastics.

Because of the applied modular technology the switching steps are equipped with the same parts as the planetary gears. A cam disc and an adjusting worm are added.

The planetary and switching steps as well as the spur gear pre-step down (not necessary for certain reductions, see gear data in chapter 1.3, table 1) are mounted into a glass-fiber reinforced modular housing of synthetic material.

The contacts (see chapter 1.3, table 2) are actuated by the cam discs of the switching steps.

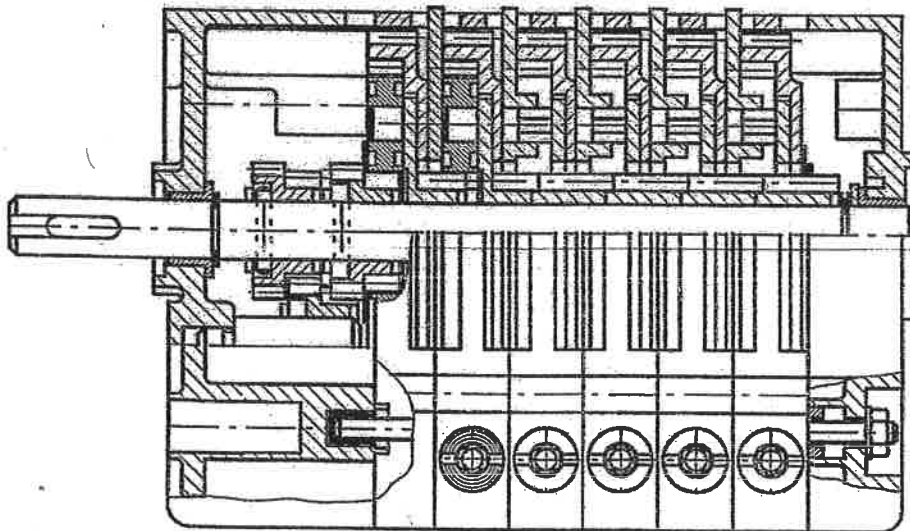

Fig. 1

DD-140181-000

Powermite House
92 Main Reef Rd P.O. Box 7745 Inter Code ++27
Jhnicon Johannesburg Tel: (011) 271-0000
Kooepeport 2000 Telefax (011) 760-3099
1724 E-mail: powermite.jhb@global.co.za
Website: <http://www.powermite.co.za>

**METSO SALSTACK PROJECT
POWERMITE COM 1348**

5. Assembly of the geared limit switch

Caution! Every person involved in operating, maintaining and repairing the limit switch must be authorized, adequately trained and instructed.

Each such person must have read and understood this instruction manual and must have been instructed in particular in relation to possible danger.

Mounting position of the geared limit switch with or without protective housing as required. The drive shall be transmitted by a flexible connection, e.g. a flexible diaphragm coupling. With chain or synchronous belt drive, etc. the admissible radial force F_{max} must not be exceeded (see Fig. 2). To protective housings, with the exceptions of compact aluminium housings, a grooved ball bearing is fitted in addition to the plain bearing. When using these housings, the admissible graphical values can be doubled.

Avoid axial forces onto the input shaft.

The ideal drive is transmitted by a torsionally stiff flexible coupling with low axial and radial restoring forces. Thereby misalignment and axial displacement are balanced.

After adjustment of the switching point on commissioning, the limit switch shall immediately be re-locked by the cap in order to prevent penetrating dust or water from affecting the switching-off safety.

Thereby accidents by touching live parts are avoided, too.

When fitting the cap pay attention that all screws are tightened uniformly in order to avoid tilting of the cap and a bad pressuring of the sealing.

The used PG-glands comply with protection IP 68. When fitting the cable pay particular attention that after insertion of the cable the tightening nut is carefully tightened. The wrench torque shall be between 2 and 3 Nm relative to the type of cable.

As a permanent deformation of the plastic sheath of some cables can occur at the contact point in the PG-gland because of contraction, it is recommended to re-tighten the tightening nut by 1/2 revolution after 3 to 4 days.

The cable conduct to the limit switch shall always be executed to prevent the cable from conducting water to the PG-gland.

Powermite House
 Main Reef Rd
 Technicon
 Roodepoort
 1724

P.O. Box 7745
 Johannesburg
 2000

Inter Code ++27
 Tel: (011) 271-0000
 Telefax (011) 760-3099
 E-mail: powermite.jhb@global.co.za
 Website: <http://www.powermite.co.za>

**METSO SALSTACK PROJECT
 POWERMITE COM 1348**

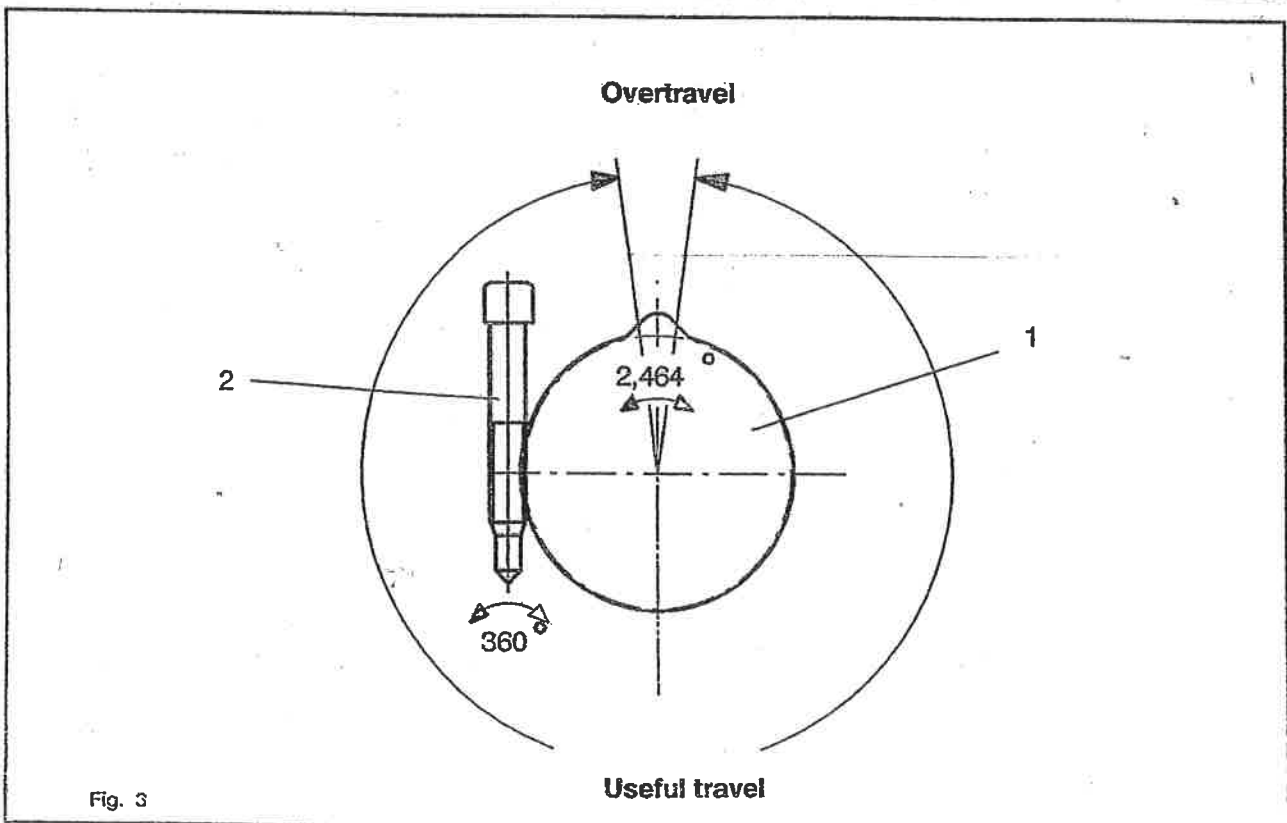
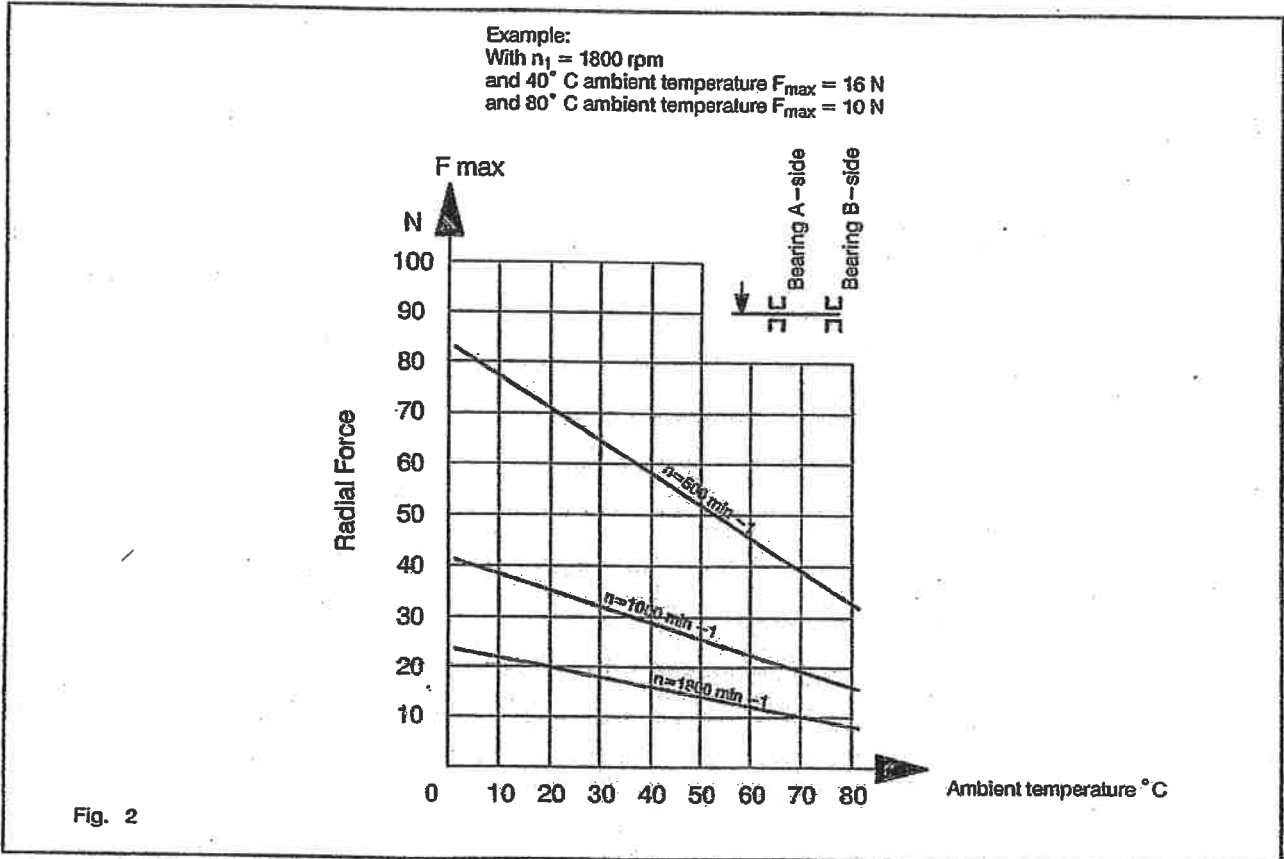

6. Commissioning

6.1 Contact adjustment (See Fig. 3)



For contact adjustment, remove the cap of the limit switch.

Thereby the live contact connections are layed bare.

Danger! Do not touch parts under voltage!

An infinitely adjustable cam disc is provided for each contact. Independently from each other, the cam discs (1) can be set with the adjusting worm (2). It is not necessary to loosen any parts for the adjustment. The worm is self-locked. The worm can be turned by means of a screw driver of 10 mm or 4 mm or by means of a hexagon socket screw key of 4 mm.

When turning the worm by one clockwise revolution (360°), the cam disc as well is turned clockwise by 2.464° (view to the rear part, the B-side of the switch).

The standard cam discs are designed to dispose of a max. useful travel and a max. overtravel (see gear data). Cam discs with other useful travels can be fitted as special discs.

When exceeding the overtravel, the switch is not damaged. The contact, however, is opened or closed again.

6.2 Block adjustment (see Fig. 4)

6.2.1 Functioning

The planetary gear construction allows a block adjustment in addition to the individual contact adjustment from the usable revolution 17.5. The final gear stage is also provided with an adjusting worm, coloured black. All cam discs (1) can be commonly adjusted by means of this adjusting worm (2). The relative adjustments of the individual contacts to each other are not modified.

When turning the black worm clockwise by one revolution (360°), the cam discs as well are turned clockwise by 0.575° (view to the rear part, the B-side of the switch).

6.2.2 Accessories for block adjustment

By means of an indicating plate (3), located on the rear side (B-side) of the switch, the adjustment can be read on a rough scale (4) (5° -graduation) at the rear panel. The indicating plate shows the position of the last cam disc. After adjustment of the last cam disc, the indicator (5) shall be set to zero. The disc is jammed and can be turned manually.

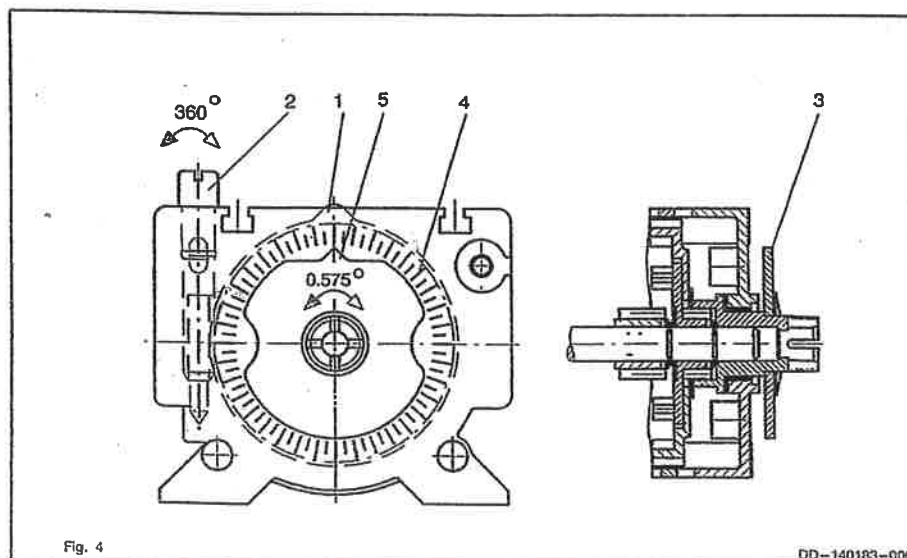

Fig. 4

DD-140183-000

Powermite House
 00 Main Reef Rd P.O. Box 7745 Inter Code ++27
 ,hnicon Johannesburg Tel: (011) 271-0000
 Roodepoort 2000 Telefax (011) 760-3099
 1724 E-mail: powermite.jhb@global.co.za
 Website: http://www.powermite.co.za

**METSO SALSTACK PROJECT
 POWERMITE COM 1348**

7. Operation



Independent from the following hints, the legal safety prescriptions for prevention of accident prescribed for the particular application case apply to the operation of this limit switch. The user is held responsible to adhere to these prescriptions.

7.1 Service conditions

The service conditions to be adhered to in order to ensure a faultless operation of the limit switch, are listed below:

The ambient temperature must not exceed 80°C and must not fall below -40°C. In case of condensation water generation in the limit switch, we recommend to fit a standstill heating. In these cases, please consult our technical after-sales service (address as per chapter 10.3).

7.2 Types of protection

In relation to the execution, the limit switches described in chapter 4 can be mounted in a protective housing of protection class IP 65 of aluminium or IP 66 of synthetic material. With already existing housings, such as switch cabinets, etc., the limit switch is used as built-in switch in protection class IP 20 (printed card execution) or IP 00 with screw terminals or plugs.

A list of housing types co-ordinated to the type of protection as per DIN 40050 is given in the following table:

Without housing, with screw terminal or plugs	IP 00
Without housing, contacts on printed card	IP 20
Housing of synthetic material execution B3/B14/B5	IP 66
Aluminium housing execution B3/B14	IP 65
Compact aluminium housing execution B3/B5	IP 65

8. Maintenance

When carrying-out maintenance and inspection works, pay attention to chapter 2 "Safety guidelines".

Generally no maintenance or inspection works at the geared limit switch are necessary. Do not remove dust deposits on the limit switches of protection IP 00, IP 20 or with open protective housings by means of compressed air. The dust would penetrate into the contacts and would affect the switching capacity.

The cap-type sealings of the protective housings have to be replaced after opening of the cap and a longer operation time.

Caution! Do not use benzine or any other solvent for cleaning of the limit switch.

9. Special executions

9.1 Execution with various cam angles

On request various cam angles (15° to 360°) can be supplied as special execution. See the following example:

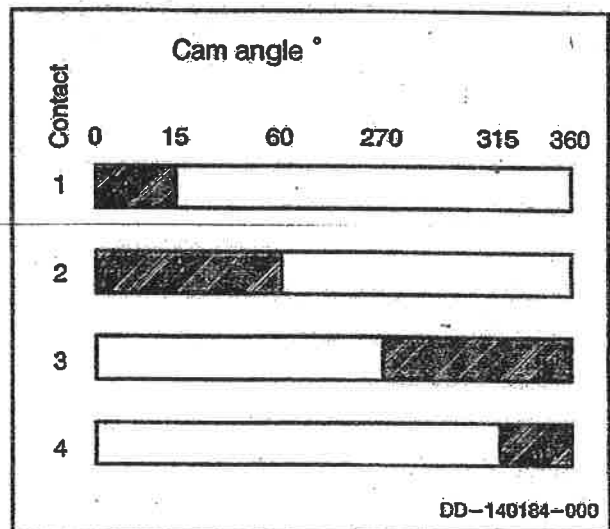

9.2 Execution with additional resistor

The resistors for analogous position feedback can be mounted to the B-side of the limit switch in two different ways (see Fig. 5).

Powermite House
92 Main Reef Rd
Johannesburg
Kooodepoort
1724

P.O. Box 7745
Johannesburg
2000

Inter Code ++27
Tel: (011) 271-0000
Telefax (011) 760-3099
E-mail: powermite.jhb@global.co.za
Website: http://www.powermite.co.za

**METSO SALSTACK PROJECT
POWERMITE COM 1348**

Execution "N"

Max. twisting angle 345°, synchronous with the revolutions of the cam discs.

Execution "S"

Max. twisting angle ~ 1470° (345° x 4.285) to drive multiturn potentiometers.

The drive is transmitted by a coupling with a 6 mm bore (use resistors with 6 mm shaft dia. only).

In relation to the execution, the resistor is fixed to a supporting sheet (3) either by a tightening nut (4) or by servoclamps (5).

The distance bolts (6) serve as torque support and connect the switch back panel to the supporting sheet metal (3). When using resistors with tightening nut (4), this nut can be used for adjustment by loosening and turning of the resistor housing. When using servoclamps (5), these ones are loosened. The adjustment is also made by turning of the resistor housing.

In case of fixations not allowing to turn the resistor housing, the nut (1) on the coupling (2) is loosened. Thereafter the shaft is turned for adjustment by means of pincers or similar.

After adjustment, all nuts or screws resp. have to be re-tightened.

If an additional cam disc assy (7) is fitted to the last position (view from the drive) for adjustment of the resistor, the adjustment of the resistor is made by the adjusting worm (8) of this additional cam disc assy without having to loosen the screws or nuts.

An available block adjustment also acts on the last cam disc assy for resistor adjustment, just as for the contact cam discs.

When making a corrective adjustment of the switch points by means of block adjustment, the potentiometer adjustment changes accordingly.

The resistor adjustment with additional cam disc assy is only possible in execution "N".

9.3 Execution with through input shaft

The input shaft can be extended through to allow driving of incremental or absolute value encoders synchronous to the driving speed.

As special design, the input shaft is conducted through the bearing plate to the drive of an incremental or absolute value encoder. For constructional reasons the encoder is located behind the bearing plate and the contact block to assure synchronous run to the driving speed.

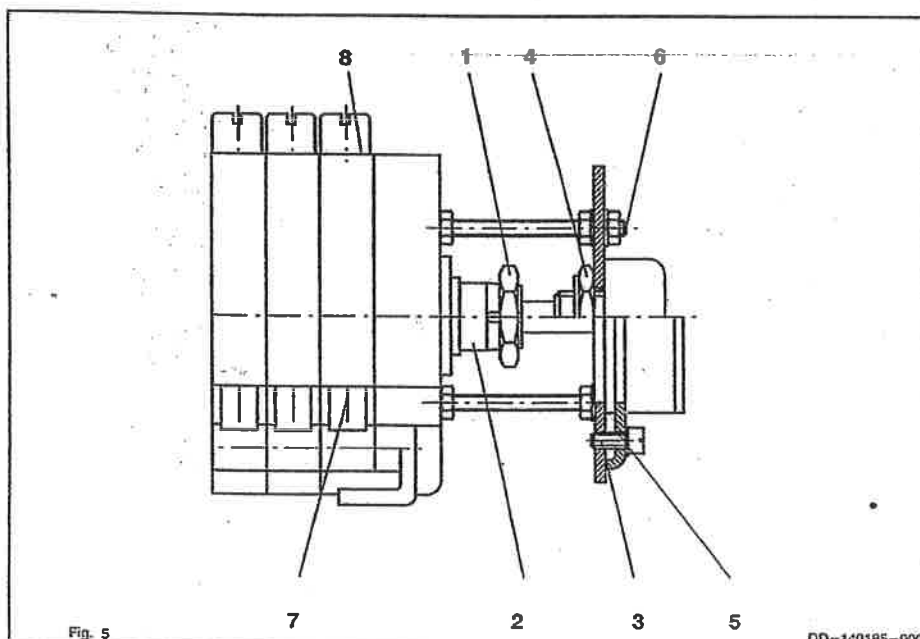
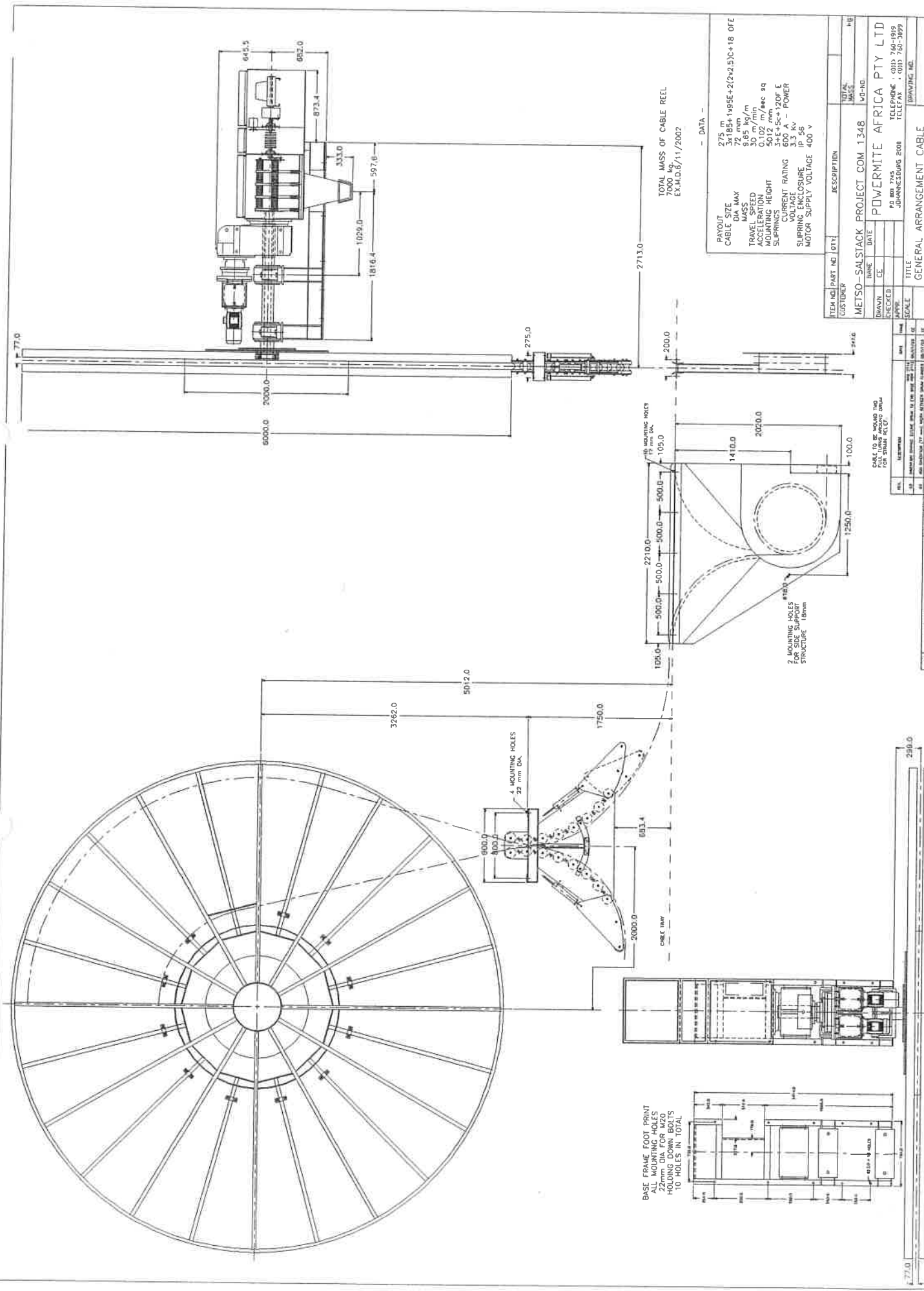

Fig. 5

DD-140185-000



BASE FRAME FOOT PRINT
ALL MOUNTING HOLES
22mm DIA FOR M20
HOLDING DOWN BOLTS
TO HOLES IN TOTAL

TOTAL MASS OF CABLE REEL
7000 kg
EX.M.D.S/11/2002

— DATA —

PAVOUT	275 m
CABLE SIZE	72 B54-195E+2(2x2.5)C+18 OFE
CABLE DIA MAX	72
MASS	9.85 kg/m
TRAVEL SPEED	30 m/min
TRAVEL TIME	5.102 m/sec sq
MOUNTING HEIGHT	3+4+5+120F E
SUPRINGS	600 A - POWER
CURRENT RATING	3.3 Kw
CONTROL	PLC
PLUG ENCLOSURE	400 V
MOTOR SUPPLY VOLTAGE	400 V

ITEM NO	PART NO	QTY	DESCRIPTION	UNIT	HT
CUSTOMER METSO-SALSTACK PROJECT COM 1348					
DATE					
DRAWN BY					
CHECKED BY					
SCALE					
TITLE POWERMITE AFRICA PTY LTD					
GENERAL ARRANGEMENT CABLE REELING DRUM TYPE					
PSM2060-FDA166/167/112/2-					
HT600-HMK20/2/112M4					
A229 00 00					
SHEET 2 OF 3					
REV. 1.00					

SCALE 1:20

REV	DATE	DESCRIPTION	BY	CHK
01	10/27/02	ISSUE FOR FABRICATION		
02	11/11/02	REVISION TO DRAWING		
03	11/11/02	REVISION TO DRAWING		
04	11/11/02	REVISION TO DRAWING		
05	11/11/02	REVISION TO DRAWING		
06	11/11/02	REVISION TO DRAWING		
07	11/11/02	REVISION TO DRAWING		
08	11/11/02	REVISION TO DRAWING		
09	11/11/02	REVISION TO DRAWING		
10	11/11/02	REVISION TO DRAWING		

REV	DATE	DESCRIPTION	BY	CHK
01	10/27/02	ISSUE FOR FABRICATION		
02	11/11/02	REVISION TO DRAWING		
03	11/11/02	REVISION TO DRAWING		
04	11/11/02	REVISION TO DRAWING		
05	11/11/02	REVISION TO DRAWING		
06	11/11/02	REVISION TO DRAWING		
07	11/11/02	REVISION TO DRAWING		
08	11/11/02	REVISION TO DRAWING		
09	11/11/02	REVISION TO DRAWING		
10	11/11/02	REVISION TO DRAWING		

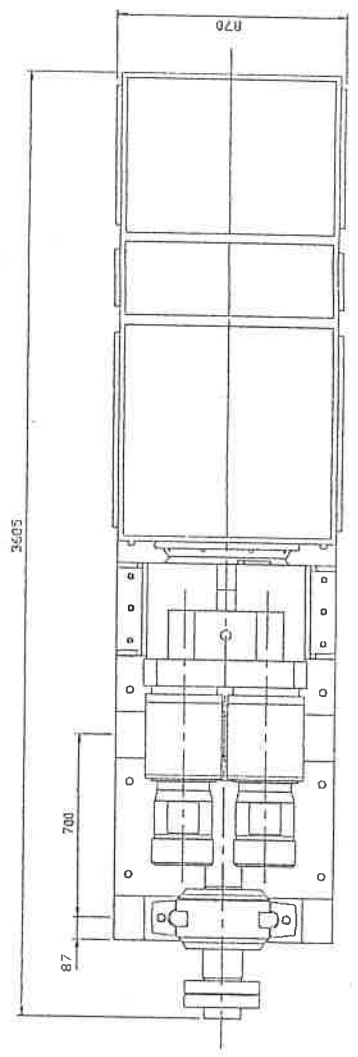
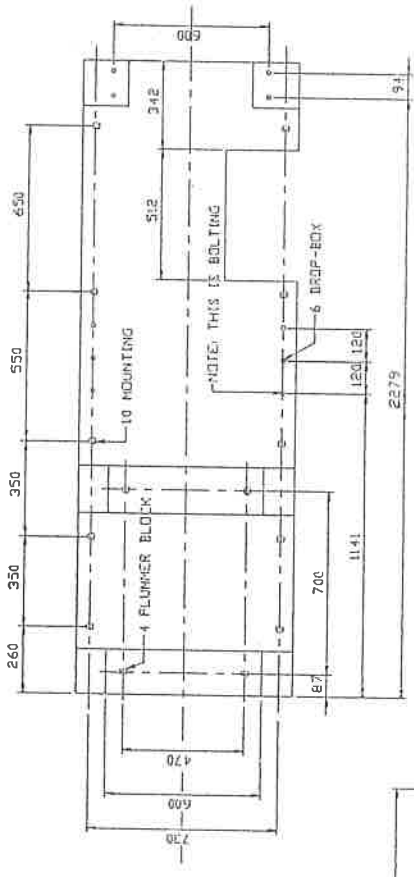
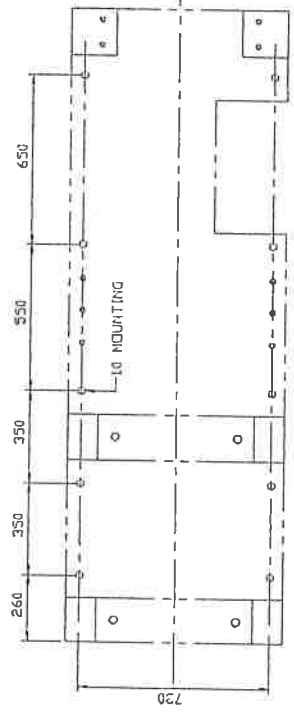
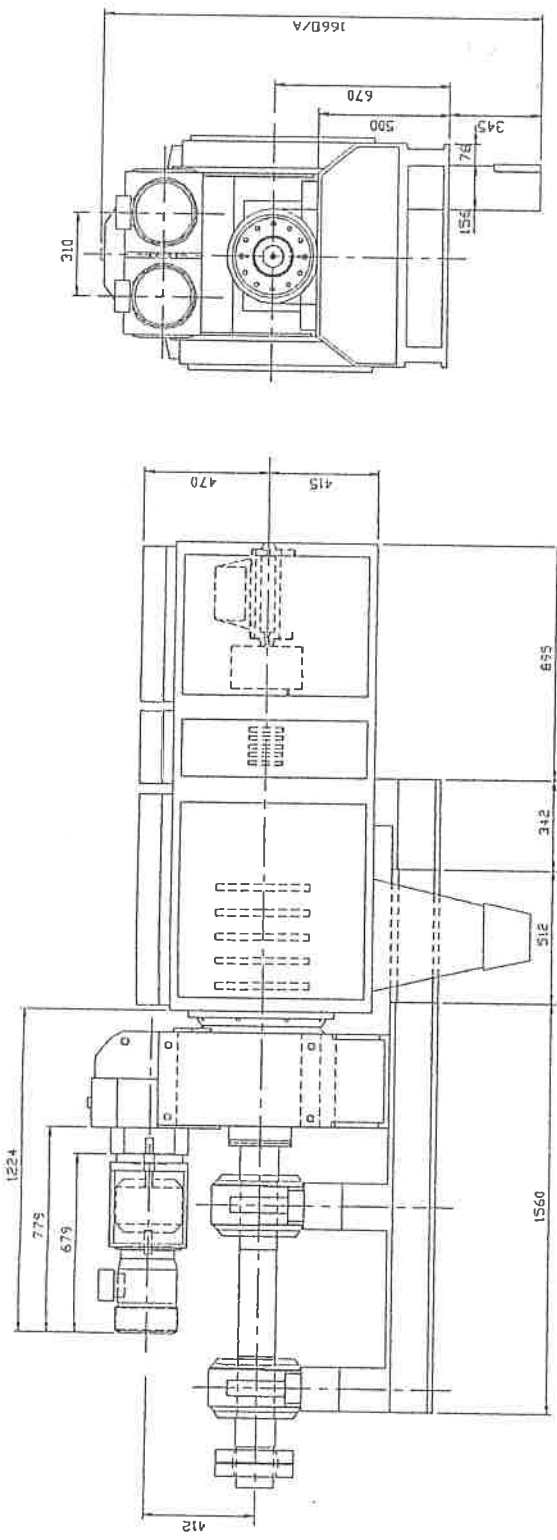

ITEM NO.	PART NO.	QTY.	DESCRIPTION	TOTAL AMOUNT	NO.
CUSTOMER			METSO - SALSTACK, 4M 1348		
NAME	DATE	POWERMITE AFRICA PTY LTD			
DRAWN	BY	30/08/07	PS BY PMS		
CHECKED	CE	30/03/01	TELEPHONE : (011) 760-1916		
APP.			JOHANNESBURG 1500 TELEFAX : (011) 760-3559		
SCALE			DRAWING NO.		
1:20			GENERAL ARRANGEMENT CABLE REELING DRUM TYPE PSN2059-FDA158/167/112/2-HT1600-HUK20/2/112M4		
			A229 00 00	SHEET 3 OF 3	
			REV 00		

POWERMITE

COMMISSIONING REPORT

FOR CABLE REEL TYPE: PSM-2060-FDA 168/167/112/2 – HT600-HMK20-2/12M4

REFERENCE: METSO – SALSTACK PROJECT

ORDER NO.: P/O 034149

CUSTOMER: METSO MINERALS

LOCATION: SALDANHA BAY / WESTERN CAPE

....., 20...

BEFORE CONNECTING TO POWER

Use page Nos.....

1. REEL:

REPORT REF. NO. RG00.T.015

		Designed for	Commission Data Comment
1.1	Check general condition visually and comment		Good/bad
1.2	Check gap between reel flanges as per drawing in at least 3 places around on spiral <u>Criteria for trailing cable O.D.:</u> if smaller than 50mm approx. + 10% = Gap if larger than 50mm + 5mm approx. = Gap - before CRD is full with trailing cable - when CRD is empty and trailing cable is reeled out.	mm mm	
1.3	Check tightness of all bolts manually – visually	OK	
1.4	CRD trailing cable entry into drum: - Check if bending diameter is within rules - Check cable gland tight? - Check cable clamping on I.D. cushioned? Yes/No Yes/No	
1.5	Check CRD running path for obstructions along the travel etc	Yes/No	
1.6	Check mounting frame construction to allow free cable movement	Yes/No	
1.7	Check visual painting quality	Good/Bad	
1.8	Check that cable catenary is constant along side the travel path to ensure even overtension detection		

Commissioning Engineer to obtain assurance from customer's Responsible person, that all circuitry & safety devices have been properly tested prior to commissioning and have been found in order and in compliance with all applicable regulations

Please Note! most of the commissioning checks are visual!

NAME.....

COMMISSIONING ENGINEER

COMPANY.....

DATE:.....

TIME:.....

POWERMITE
COMMISSIONING REPORT
FOR CABLE REEL TYPE: PSM-2060-FDA 168/167/112/2 – HT600-HMK20-2/12M4

BEFORE CONNECTING TO POWER

2. DRIVE TRAIN:

		Designed for	Commission Data Comment
2.1	Motor/s : <input checked="" type="checkbox"/> State reading on rating plate: - Electric A.C./D.C supply voltage etc. - check/measure supply voltage - check correct rotation of Drives "A" and "B" motor (to match markings) - check that all cover lids are properly closed - check tightness of fixing bolts - check permanent magnet clutch on Drives "A" and "B" for correctness of gap Yes/No Yes/No Yes/No Yes/No
2.2	Check holding brake on Drive "B" and adjust air gap and hand release (if fitted) <input checked="" type="checkbox"/>mm
2.3	Check gearbox - check oil level (dipstick) - check breather clear? - check tightness of fixing bolts	Yes/No Yes/No Yes/No
2.4	Permanent magnetic clutch/es - check brake effect by turning manually against rotation - check final torque to match with CRD trailing cable data "Power on" than using a scale (15N/mm ² not to be exceeded) - check functionality of micro switch on brake of Drive "B" (if fitted)		
2.5	Chains: (if fitted) - check correct slack - check if Master link secure? - check if lubrication is acceptable	Yes/No Yes/No Yes/No
2.6	Check painting quality of drive train visually	Good/bad

Commissioning Engineer to obtain assurance from customer's responsible person, that all circuitry and safety devices have been properly tested prior to commissioning and have been found in Order and in compliance with all applicable regulations!
 Please Note: most of the commissioning checks are visual!

NAME.....
 COMMISSIONING ENGINEER
 COMPANY:.....
 DATE:.....
 TIME:.....

POWERMITE COMMISSIONING REPORT

**FOR CABLE REEL TYPE: PSM-2060-FDA 168/167/112/2 – HT600-HMK20-2/12M4
BEFORE CONNECTING TO POWER**

3. SLIPRING UNIT:

		Designed for	Commission Data Comment
3.1	Voltage of sliprings – Power - Control Optical fibre rotary coupler rotation Volt Volt over travel distance
3.2	Slipring material - Power /brass - Control /brass - check tightening of bolts and bushes A A Yes/No	
3.3	Check brush material for correct match to slipring surface	Brush: Slipring:	
3.4	Are brush holders properly set onto slipring? <input checked="" type="checkbox"/>	Yes/No	
3.5	Are brushes properly bedded into slipring? <input checked="" type="checkbox"/>	Yes/No	
3.6	Are sliprings clear of obstructions? <input checked="" type="checkbox"/> (Turn reel manually)	Yes/No	
3.8	Check brush holders and sliprings in slipring compartment for correct airgap Guide : 1 kV min. 25mm 3.3kV min. 65mm 6.6kV min. 90mm 11kV min. 115mm		
3.9	Check electrical cable connection to brush holders: <input checked="" type="checkbox"/> - being flexible & non restricting - bolts tight	Yes/No Yes/No	
3.10	Check that flexible limits of slipring construction ensure uninterrupted contact of brushes at all times	Yes/No	
3.11	Check connection of anticondensation heater (if installed)	Yes/No	
3.12	Check if earth ring/s are properly fitted and connected	Yes/No	
3.13	Check that enclosure is IP.....	Yes/No	
3.14	Visual painting quality check	Good/bad	

NAME:.....

COMMISSIONING ENGINEER

- Commissioning Engineer to obtain assurance from Customer's responsible person that all circuitry and safety devices have been properly tested prior to commissioning and have been found in order and in compliance with all applicable regulations!!

COMPANY

DATE:.....

Please note : most of the commissioning checks are visual!!

TIME:

**POWERMITE
COMMISSIONING REPORT**

FOR CABLE REEL TYPE: PSM-2060-FDA 168/167/112/2 – HT600-HMK20-2/12M4

BEFORE CONNECTING TO POWER

4. GEAR CAM LIMIT SWITCH (in Slipping Housing)

		Designed for	Commission Data Comment
4.1	Check limit switch setting: <input checked="" type="checkbox"/> - check wire connections to microswitches for correct fitting and circuit incorporation - check empty drum (2 layers on) for OFF position - check full drum, must be min. 150mm under reel tyre for OFF position - check centrefeed bridging of slack cable Limit Switch - check and set control setting for Drive "B" - check other special function setting (see remarks, if any)		
4.2	Are all set functions properly incorporated into circuitry by others and tested <input checked="" type="checkbox"/>	Yes/No	
4.3	Check tightness of fixing bolts	Yes/No	
4.4	Is coupling properly aligned? - visual check	Yes/No	

REMARKS:

Commissioning Engineer to obtain assurance from customer's responsible person that all circuitry and safety devices have been properly tested prior to commissioning and have been found in order and in compliance with all applicable regulations!

Please Note: most of the commissioning checks are visual!

NAME:.....
COMMISSIONING ENGINEER

COMPANY:.....

DATE:.....

TIME:.....

POWERMITE
COMMISSIONING REPORT

FOR CABLE REEL TYPE: PSM-2060-FDA 168/167/112/2 – HT600-HMK20-2/12M4

BEFORE CONNECTING TO POWER

5. OVERTENSION DEVICE ON FEED IN FUNNEL

		Designed for	Commission Data Comment
5.1	Feed in funnel in line with reel/deflector (if not, how far out?)	Yes/No	
2	Rollers: 1. Free running	Yes/No	
	2. Grease nipples clear (if any)	Yes/No	
	3. Bolts and nuts properly secured?	Yes/No	
	4. Angle of cable contact movement in guide funnel	85°	
5.3	Set/check overtension limits based on max. allowable cable tension of 3 power cores only at 15N/mm ²	 Kg (scale measure)
	5.3.1 Check operation of Limit Switch contacts - normally closed without overtension - open contact on overtension, in both directions	Yes/No	
	5.3.2 Limit Switch function test (signal received) w/o power	Yes/No	
5.4	Are dancing levers moving freely and activate Limit Switch	Yes/No	

REMARKS:

Commissioning Engineer to obtain assurance from customer's responsible person that all circuitry and safety devices have been properly tested prior to commissioning and have been found in order and in compliance with all applicable regulations!

NAME:.....
COMMISSIONING ENGINEER

Please Note: most of the commissioning checks are visual!

COMPANY:.....

DATE:.....

TIME:.....

**POWERMITE
COMMISSIONING REPORT**

FOR CABLE REEL TYPE: PSM-2060-FDA 168/167/112/2 – HT600-HMK20-2/12M4
BEFORE CONNECTING TO POWER

6. SLACK CABLE DEVICE ON FEED IN FUNNEL

		Designed for	Commission Data Comment
6.1	Set slack cable lever into vertical position	Yes/No
6.1.1	Check bridging circuit to cut slack cable Limit Switch over Centrefeed unit (bridged by gear cam Limit Switch (see Item 5)	Yes/No
6.1.2	Check operation of contacts of slack cable Limit Switch		
6.1.2.1	Contact closed when cable is tensioned (lever left or right of vertical)	Yes/No
6.1.2.2	Contact open when cable is slack (lever vertical)	Yes/No
6.1.3	Function Test (signal received) w/o power	Yes/No
6.1.4	Are all set functions properly incorporated into circuitry by others?	Yes/No
6.2	Approx. angle at which lever operates position 6.1.2.2 above (sketch Drawing below)°	Degree° to left or right of vertical.
6.3	Bolts and nuts properly secured?	Yes/No
1.3.1	Lever straight and guided by flexible cable?	Yes/No
1.3.2	Rollers clean on surface and adequately curved to receive cable O.D.?	Yes/No

REMARKS:

Commissioning Engineer to obtain assurance from customer's responsible person that all circuitry and safety devices have been properly tested prior to commissioning and have been found in order and in compliance with all applicable regulations!

NAME:.....
COMMISSIONING ENGINEER

Please Note: most of the commissioning checks are visual!

COMPANY:.....

DATE:.....

TIME:.....

**POWERMITE
COMMISSIONING REPORT**

**FOR CABLE REEL TYPE: PSM-2060-FDA 168/167/112/2 – HT600-HMK20-2/12M4
BEFORE CONNECTING TO POWER**

7. CENTRE FEED

		Designed for	Commission Data Comment
7.1	Check proper installation		
	7.1.1. Was cable tension relieved when wound around centre feed drum?	Yes/No
	7.1.2. water drainage	Yes/No
	7.1.3 gland entry sealed and tight	Yes/No
	7.1.4 cable clamping before entering junction box is cushioned and tight	Yes/No
	7.1.5. flexible cable installed according to Powermite Cable Installation instructions	Yes/No
	7.1.6 State cable layers on centrefeed unit drum in reserve for tension relief	min. 2 off
	7.1.7 Bending diameter of cable looping from centrefeed drum via curved cable funnel to cable settlement on floor	min. 25 x OD

REMARKS:

Commissioning Engineer to obtain assurance from customer's responsible person that all circuitry and safety devices have been properly tested prior to commissioning and have been found in order and in compliance with all applicable regulations!

NAME:.....
COMMISSIONING ENGINEER

Please Note: most of the commissioning checks are visual!

COMPANY:.....

DATE:.....

TIME:.....

POWERMITE
COMMISSIONING REPORT
 FOR CABLE REEL TYPE: PSM-2060-FDA 168/167/112/2 – HT600-HMK20-2/12M4
BEFORE CONNECTING TO POWER

8. FLEXIBLE TRAILING CABLE / HOSE:

		Designed for	Commission Data Comment
8.1	State general condition of floor surface:	even/uneven/ clean/gravel/m uddy
8.2	<u>If cable was installed by others:</u> Ensure that cable was installed as per Powermite "Flexible Cable Installation Instructions" CA00.T.002, REV3	Yes/No	
8.3	State length of travel - Power cable - Control cablemm	
8.4	State diameter of flexible cable - Power cable - Control cablemmmm	
8.5	Are bending diameters within Powermite's "Basic rules for bending flexible cables" (see Cable Catalogue Table 8)	Yes/No	
8.6	State number of cable layers/coils on CRD, when full	
8.7	Is cable tension relieved when wound on Centrefeed-drum	
8.8	Check cable winding quality onto drum	Yes/No	
8.9	Spiral drum: State gap between wheel flanges (see Item No. 1.2)mm	
8.10	Spiral drum : state cable OD and if cable winds untwisted/unstressed	Yes/No	
8.11	State catenary length of cable measured from last roller of guide funnel to touch down on floor surface - Trailing cable - Power - Trailing cable - Control check that cable catenary is of same shape i.e. "height to floor", during travelmm	
8.12	Check if cable is correctly clamped and terminated <input checked="" type="checkbox"/>	Yes/No	

Commissioning Engineer to obtain assurance from customer's responsible person, that all circuitry and safety devices have been properly tested prior to commissioning and have been found in order and in compliance with all applicable regulations!!

Please Note: most of our Commissioning checks are visual!

NAME:
 COMMISSIONING ENGINEER

COMPANY:.....

DATE:

TIME:

POWERMITE
COMMISSIONING REPORT
 FOR CABLE REEL TYPE PSM-2060-FDA 168/167/112/2 – HT600-HMK20-2/12M4

9. AFTER SWITCHING ON POWER:

		Designed for	Commission Data Comment
9.1	Check for correct rotation of motors	Forward/ Reverse	
9.2	Are clearances of Powermite Cable Reeling Drum moving parts, to other adjacent equipment, acceptable?	Yes/No	
<u>DURING RE-POSITIONING</u>			
9.3	Check trailing cable performance onto drum - spiral/cylindrical (in acc. with Cable Installation - Instruction) CA00.T.002 REV3	Yes/No	
9.4	Check overtension & slack cable limit switches and other levers for functionality	Yes/No	
9.5	Check guide rollers on various CRD parts for functionality.	Yes/No	
9.6	Check if anticondensation heater (where applicable) is working – do not open Slipring enclosure if High Tension voltage is switched on!	Yes/No	
9.7	Check both limit switch limits when HT trailing cable is off/fully stored on CRD. m	
9.8	Check if Drive “B” is correctly energised by the setting of the gear cam limit switch	Yes/No	
9.9	Check if gear cam limit switch contacts bridge slack cable limit switch over centrefeed	Yes/No	
9.10	Check gearbox Check for noise level and state	Quiet/Noisy	
9.11	Check : CRD drive train for correctness as per Manual Com 1346) Check : Drive “B” brake monitoring by micro switch Check : Gear cam limit switch function as per Item 5	Yes/No Yes/ No Yes / No	
9.12	Conduct a hand operated reeling exercise with H.T. trailing cable on CRD against the permanent magnet clutch torque.	Yes/No	

NAME:.....
 COMMISSIONING ENGINEER

Commissioning Engineer to obtain assurance from customer's Responsible person, that all circuitry & safety devices have Been properly tested prior to commissioning and have been found in order and in compliance with all applicable regulations.

COMPANY:.....
 DATE:.....
 TIME:.....

Please Note! most of the commissioning checks are visual

POWERMITE COM. NO. 1348

DESCRIPTION

TANDEM DRIVE FOR
MONO SPIRAL CABLE REEL

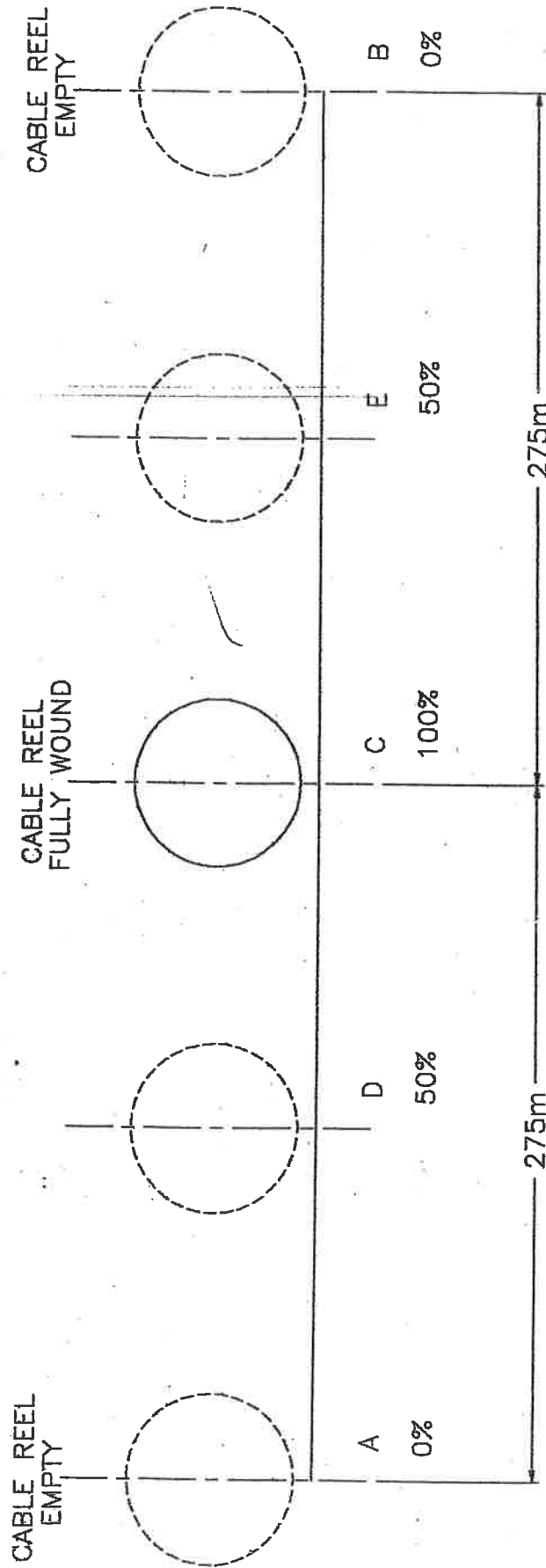

A - B = TOTAL TRAVEL DISTANCE OF MACHINE

OPERATION OF A 2ND MOTOR DRIVE (DRIVE "B") ASSISTING THE PRINCIPAL DRIVE (DRIVE "A") WHEN ADDITIONAL TORQUE IS REQUIRED.

SEE CRD MANUAL FOR MORE DETAILS

REV.	DATE	DESCRIPTION	BY	CHK.

POWERMITE AFRICA (PTY)LTD.
 POWERMITE HOUSE
 82 MAIN REEF ROAD
 TECHNIKON
 ROODEPOORT
 124, ROODEPOORT
 P.O. BOX 7745
 JOHANNESBURG 2000

TELEPHONE : (011) 271-0000 (32 LINES)
 TELEFAX : (011) 760-3088
 EMAIL : powermite.jhb@global.co.za
 INTERNET : <http://www.powermite.co.za>

DRAWN : S. GOMERSALL
 APPROVED : [Signature]
 DATE : 10/09/02
 STOCK NO. :
 SCALE N.T.S. | TOL. ±0.2 | DRG. NO. RG00.T.011 REV. 0

THIS DRAWING IS THE PROPERTY OF POWERMITE AFRICA (PTY)LTD AND IS SUBJECT TO THEIR REGAL AND MUST NOT BE REPRODUCED OR ITS CONTENTS INFRINGED WITHOUT WRITTEN PERMISSION



COMMISSIONING PLAN

COMMISSIONING PLAN

For: Transnet Port Terminals (TPT), Saldanha

Project Name: FEL 3 Saldanha Bulk Terminal Equipment Refit:
Stacker Reclaimers, Shiploaders and Tippler 2.
(Phase-4: Stacker Reclaimer 3)

Project Number: Z.5200160

Author: World Crane Services (TPT Consultant)
Owner: Louis du Toit (Terminal Manager)
Client: Transnet Port Terminals (TPT)
Project Sponsor: Andiswa Dlanga (Managing Executive)
Project Manager: Graham Handley

Revision Number: 00
Approved by: K. Niemand

Document No: Z.5200160-CP

DOCUMENTATION DISTRIBUTION, REVISION AND APPROVAL HISTORY

REVISION NUMBER	DATE	DISTRIBUTION/ REVISION	PREPARED BY	REVIEWED BY	APPROVED BY
00	26/03/2021	00	WCS	G. Handley M. Mazubane	K. Niemand

SIGNATORIES:

Prepared by:

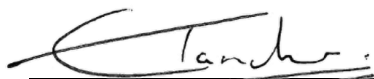
World Crane Services
Consultant

26/03/2021

Date

Reviewed by:

Graham Handley
Snr. Project Manager

26/03/2021

Date

Reviewed by:

Mphilisi Mazubane
Snr. Manager

26/03/2021

Date

Approved by:

K. Niemand
Engineering Manager

31/03/2021

Date

Table of Contents

1.	PURPOSE.....	5
2.	INTRODUCTION.....	5
3.	COMMISSIONING PROCESS.....	5
3.1	Safety during Commissioning.....	5
3.2	Tags.....	6
3.3	Lockout procedure.....	6
3.4	Commissioning Planning and Coordination.....	6
3.4.1	Principal Contractor’s Commissioning Plan.....	6
3.4.2	Commissioning Teams.....	7
4.	COORDINATION OF ALL COMMISSIONING ACTIVITIES.....	8
4.1	DAILY COORDINATION AND PLANNING MEETING.....	8
5.	PRE-REQUISITES FOR COMMISSIONING.....	8
5.1	Testing and commissioning.....	9
6.	COMMISSIONING APPROACH.....	10
7.	STAGES OF COMMISSIONING.....	11
7.1	Stage 1 – Pre-commissioning / Completion of Erection and Installation.....	11
7.2	Stage 2 – Cold Commissioning.....	12
7.3	Stage 3 – Hot Commissioning (System Integration and Load Tests).....	13
8.	PUNCH LISTING.....	15
8.1	Equipment Modifications.....	16
8.2	Safety Clearance Inspection.....	17
8.3	Statutory Certification and Approvals.....	19
8.4	Verification of Commissioning Activities.....	19
8.5	Care, Custody and Control.....	20
8.6	Spares.....	21
9.	ORGANISATION.....	21
10.	COMMISSIONING SCHEDULE.....	21
11.	SAFETY.....	21
12.	HAND-OVER PROCEDURES.....	22
12.1	Red Lining” of Commissioning Drawings.....	22
12.2	Training and Manning.....	22



12.3	Contractual Certification	23
12.4	Mechanical Completion Certificates	23
12.5	Cold Commissioning Certificates	23
12.6	Completion Certificates.....	24
12.7	Final Certificates	24
13.	RECORDS.....	24
14.	ANNEXURES	25

Annexures

Annexure 1 - Commissioning Responsibility Matrix

Annexure 2 - Commissioning File Contents

Annexure 3 - Mechanical- and Electrical Completion Certificate/RFC Certificate

Annexure 4 – Completion of Cold Commissioning Certificate

Annexure 5 - Completion/Take-over Certificate

Annexure 6 – Commissioning Team Organogram

1. PURPOSE

The purpose of this Commissioning Plan is to describe a standard approach to the commissioning management process, define the various stages of commissioning. This Commissioning Management Functional Execution Plan is directed mainly at Mechanical and Electrical Works. Structural works are subject to a fully comprehensive sampling, testing, inspection and quality control in accordance with SANS standards and procedures or best international practices including verification of dimensions and tolerances in accordance with plans, drawings and specifications and as such the commissioning of structural works are limited to the completion of punch list items.

2. INTRODUCTION

The appointed Principle Contractor will be responsible for the final detailed execution plan of the *works* and arrangements. This document gives basic guidelines of what is expected during the commissioning phase. It shall be the Principle Contractor's responsibility to complete all work as per scope, work-off all safety related punch list items, do safety checks with support of the Client's Operational Team & Commissioning Manager, sign-off completion of safety checks with client, obtain Ready for Certificate Commissioning (RFC), do Cold Commissioning with support of Client's Team, run the system and carrying out all necessary adjustments, sign completion of Cold Commissioning Certificate, do Hot Commissioning with material/Iron Ore under full operational production and proof equipment under original design load capacity. At completion of commissioning, acceptance certificate is to be completed and signed-off.

3. COMMISSIONING PROCESS

The Principle Contractor shall be responsible for organising and carrying out all the equipment tests and trials as specified in the relevant contract documents. The Principle Contractor shall be responsible to ensure that all the applicable statutory tests and design code requirements are met and that the necessary representatives of these agencies are present to witness these tests where applicable. Where the ultimate user is responsible for statutory testing and/or registration of plant and equipment, he/she shall arrange for such testing and/or registration.

3.1 Safety during Commissioning

The appointed Commissioning Manager will be in control of all Commissioning Activities: During the Commissioning phase, safety measures, to prevent the plant from being energised or being operated accidentally are of paramount importance. This is to be achieved by co-ordination of all Commissioning activities and the use of a common Lock-

Out System that will prevent people from accidentally operating isolated plant/equipment and which will, always, indicate the commissioning status of the piece of equipment being commissioned.

All personnel, whether from BTS, Transnet Port Terminals or Contractors who will be involved in the isolation and Lock-out of the plant, must be trained and appointed as "responsible persons" of the Commissioning Team. They will be tested to ensure that they have sufficient knowledge of the plant and the Lock-Out System, to carry out their duties in a safe manner, not endangering their own lives or those of other people working on the plant or put the plant itself at risk. Responsible/Appointed persons will perform their duties under the general supervision of a competent person in terms of the OHS Act, General Machinery Regulations 2.

3.2 Tags

A system of tags will be used to provide a record of inspection and checks to facilitate a systematic check out of equipment and ensure the safety of all involved.

3.3 Lockout procedure

A safe lockout procedure shall be implemented, under the control of the BTS Engineering- and Operation Managers and strictly imposed to ensure the safety of personnel engaged on the work of commissioning and start-up.

BTS to ensure sufficient Lock-out and Commissioning training are provided to ALL personnel that will be involved during the commissioning stages.

Responsibilities on permit transfer, lock-out procedures will be covered under the training and preparation for commissioning.

3.4 Commissioning Planning and Coordination

3.4.1 Principal Contractor's Commissioning Plan

The Principle Contractor shall prepare and supply a commissioning plan to cover the overall commissioning of completed work under his scope of work. This commissioning plan shall also consist of an organogram indicating all Commissioning Engineers and other staff required for the commissioning process and a detailed commissioning schedule showing all commissioning activities on a 24/7 hourly scheduled basis. This Commissioning plan shall be reviewed and approved by the TPT Project Manager.

3.4.2 Commissioning Teams

The Principal Contractor’s Commissioning Manager will take the overall responsibility for all commissioning activities. The Commissioning Manager will be assisted by a team of Engineers from all disciplines which were involved during the refurbishment execution, to make-up the Commissioning Team, with members and representatives from all departments (ECM Team, TPT projects, BTS and the responsible Principal Contractor).

The Principal Contractor shall designate representatives of his staff to assume responsibility for the complete inspection and testing of all work within the scope of his contract and to participate in commissioning activities. The Principal Contractor shall be responsible for and co-ordinate all the work of its sub-contractors. Commissioning Teams will be identified using the format shown in Table 1.

Table 1: Identification of Commissioning Teams

Commissioning Teams			
TPT Project Manager			
TPT (ECM) Commissioning Manager			
Discipline	Principal Contractor	ECM Team	BTS/ Client Eng. & Comm. Team
Mechanical	X	X	X
Electrical & Instrumentation	X	X	X
Structural/Operations			X (Operations)
QC	X	X	X
Safety	X	X	X

Refer to Annexure 6, the proposed Organogram for the Commissioning Resources.

4. COORDINATION OF ALL COMMISSIONING ACTIVITIES

4.1 DAILY COORDINATION AND PLANNING MEETING

Each morning a commissioning coordination and planning meeting will be held to review the following:

- Commissioning safety permit status, safety isolation and lock-outs, planned for the day
- Safety and new hazardous conditions
- Testing, shutdowns, tie-in's and work planned for the day
- Commissioning status and short-term forecasts
- Defect list punching and back-punching activities for the day
- Issues requiring resolution

The coordination meetings will be very brief with limited discussions. Participants will be encouraged to resolve issues immediately following the meeting and report back on the conclusions at the next morning's meetings.

These meetings will be attended by all the members representing all teams (BTS, TPT, EPCM and Principal Contractor).

The commissioning meeting may form part of the daily feedback meeting. The daily meeting will be chaired by the TPT Senior Project Manager and attended by all required stakeholders

5. PRE-REQUISITES FOR COMMISSIONING

A complete and detailed test and inspection protocol for testing of pre-assembled modules (if applicable), as well as the request for commissioning of all equipment to be commissioned, shall be submitted by the Principle Contractor for approval by TPT Project Manager, ECM Construction- and Quality Manager, before the start of testing and/or commissioning.

This test and inspection protocol shall include all tests and inspections required in terms of the respective specifications and other tests and inspections deemed necessary by the Principal Contractor to prove to the Employer's satisfaction that the equipment complies with the Works Information and must include the following where applicable:

- Signed-off Completion Certificates for all Mechanical- and EI&C Installation.

-
- Principle Contractor to apply and obtain a Mechanical Completion certificate/ "Ready for Commissioning Certificate: (RFC)
 - Pre-commissioning (Cold Commissioning) tests to be performed by the Contractor
 - Tests to prove the integrity of the safety devices, limit systems and emergency systems
 - Tests to prove the integrity of all service stops and emergency stops.
 - Complete Cold Commissioning
 - Commence with Hot Commissioning, with Iron Ore material, with support of BTS.
 - Full load tests to all mechanical- electrical- and conveyor equipment on effected route.

Functional tests

- Operational tests during Cold Commissioning, without material.
- Endurance/Proofing test of 40 hours, under full designed load for SR3 as complete operating system.
- Hot Commissioning Certificate will be signed-off and the project to be taken over by the Client/BTS on completion of endurance tests.

5.1 Testing and commissioning

BTS representatives work together with the Projects team and Contractor's commissioning team during the commissioning and testing phases.

Modules pre-assembled off site shall be trial assembled and fully tested as far as practical and be accepted by the projects team prior to delivery to site. All tests performed off site shall be repeated on completion, of refit scope of work planned for SR3, before commissioning starts, the Contractor shall satisfy himself that the installation is complete in all respects and shall carry out the necessary pre-commissioning tests.

During this period the Construction Manager will carry out visual inspections on the equipment. After approval of the test and inspection protocol by the Project Manager, the Contractor shall fully test the equipment in the presence of TPT/BTS Maintenance, Operations and Quality in accordance to the approved protocol. As far as practical the equipment shall be fully tested prior to it being Hot Commissioned.

All motions of the equipment shall be tested, during Cold Commissioning Phase, to prove correct operation and to enable position indicators and limit switches to be set, and other operational adjustments made.

Before the commencement of any tests, the Principal Contractor shall provide the initial fill of oil for all new/refurbished equipment supplied by the PC as part of their scope. Oil and grease for components supplied, to be lubricated as per OEM's/Transnet Specifications. All other existing components requiring top-up lubrication to be topped-up with lubrication, (grease and oil) supplied by BTS.

6. COMMISSIONING APPROACH

Project execution plan details the basic activities and durations to be completed and Mechanical and Electrical completion certificates to be signed off by all required parties. Commissioning Manager will then issue the Mechanical Completion Certificate/ Ready for Commissioning Certificate (RFC) before Cold Commissioning may commence.

For the detailed scope of work refer to latest Owner Requirements & Specification (Ref. Z.5200160-ORS) and the Engineering Report (Ref. Z.5200160-ER).

The commissioning for the refurbished equipment will be monitored and carried out as per agreed commissioning schedule; the table below shows the major equipment infrastructures subject to commissioning.

Table 2: Phase 4 Equipment subject to commissioning/endurance testing

Stacker Reclaimer and tripper car 3 complete System

The hours recorded for operating the entire stream will be utilised as the commissioning hours, TPT operations will be expected to provide a document indicating the hours achieved during Hot Commissioning. This document must contain the conveyor selection route and the hours recorded for each route. The hours will be added up to achieve the endurance testing objectives, which are 40hrs (either continuous or consecutive sessions) for the system operating under load.

Structural work and corrosion protection will be inspected, and data packs signed off, representatives from the Project Team must participate during inspection, and if any findings lead to the rejection of the final work, the contractor must re-visit the works information and execute the work accordingly to meet the specified quality.

7. STAGES OF COMMISSIONING

Please note: The Principal Contractor will not be allowed to proceed to Cold Commissioning until all Category A items have been resolved i.e. the plant may not be energized and run without all the safety requirements being met.

Priority Legend

Category A: Items which compromise the safety and the integrity of BTS
(Examples: Instrumentation, Start-up & Operational Control; All safety devices/pull wires; safety guards not properly installed; lose bolts; unsafe grating/access; insufficient lighting and firefighting equipment or un-grouted components etc.)

Category B: Operational requirements i.e. items which might cause operational delays e.g. spillage; belt skews; not sufficient operation personnel to commence with commissioning etc.

Category C: Items which can be completed after start up and must be completed prior to final acceptance e.g. painting; smaller adjustments not effecting the safe operation of the equipment and work that can be executed during the next scheduled maintenance window.

7.1 Stage 1 – Pre-commissioning / Completion of Erection and Installation

The Stage 1 activities are all those activities that take place prior to Cold Commissioning including Mechanical/EI&C and Physical completion ready to be subjected to functional testing, Punch listing (defect list) and completion of all Category A and B punch items. Mechanical/Mechanical/EI&C and Physical completion includes running the conveyor selection routes, flushing, hydro testing, pressure testing and other test necessary before being integrated into functional modules.

The term Mechanical Completion refers to the physical completion of work regardless of the discipline involved i.e. Physical completion of electrical instrumentation and control work is termed "Mechanical Completion".

When tests and/or checks are to be carried out to demonstrate Mechanical Completion that involves the application of energy, such as running the conveyor selection route, a safe working procedure must be developed by the Contractors and demonstrated to the relevant Commissioning Manager.

A Safety Clearance Certificate is issued after the completion of Stage 1 (a copy of which must be filed in the commissioning file and the original retained by the Contractor). In situations, such as sub stations, where no energy or livening up is required before the commencement of the Hot Commissioning, the Safety Clearance Certificate is only issued at the end of Cold Commissioning.

Depending on the contractual interfaces, more than one Safety Clearance Certificate may need to be issued for a functional entity to ensure that "user" responsibility is adequately defined and accepted.

For Structural, work where no commissioning involved, only a Completion Certificate is required once the required Punch List items are cleared.

7.2 Stage 2 – Cold Commissioning

Cold Commissioning activities are those required to bring any plant system, stream, module, unit from the status of mechanical completion to the point where Hot Commissioning may commence under the supervisory control of the relevant contractor and the issue of Cold Commissioning Certificate. This will entail running the system, Module or Unit under no load conditions and where applicable, on automatic control with stimulations as required.

Cold Commissioning activities are non-operating adjustments and cold alignment checks made by the contractor, in accordance with detailed checklists. The activities cover a very wide range and include checks on electrical, motors, control and safety systems as well as running the plant under simulated conditions without load.

Before any Unit, Module or System is energised during Cold Commissioning a Safety Clearance Certificate must be issued. Updated Maintenance Manuals to be prior to Cold Commissioning, for information to be captured into the SAP maintenance system.

No Cold Commissioning will be allowed unless the Contractor has submitted the commissioning, operating, maintenance manuals and mechanical completion certificate have been issued for the Contract Works or part thereof. Red lined "as built" drawings must be available and must be kept up to date as the commissioning process continues.

a) Testing of Individual Equipment (Units)

This stage of Commissioning consists of the complete inspection, testing and operation of each piece of equipment individually, including electrical control and power wiring which has been connected to the equipment, as well as, the checking of the configuration and

calibration of each instrumentation loop. It is the Contractors responsibility to carry out Cold Commissioning related to the Scope of work, as defined in the relevant contract, to the satisfaction of the responsible Commissioning Team. The responsible Commissioning Team will provide technical assistance where necessary and will witness the inspections/tests.

b) Testing Modules and Systems (Functional Tests)

This stage of Commissioning consists of the testing and operation of the Works, grouped together into modules and/or systems, as agreed between the Commissioning Manager and the Contractor.

At the end of the Cold Commissioning stage, the Contractor shall have corrected all the deficiencies that the Commissioning Team deems necessary to allow Hot Commissioning to continue in a safe and controlled manner. The project Engineering Lead, Commissioning Manager and the Project Manager may agree that some minor deficiencies could be corrected during the Hot Commissioning stage. Where specifically agreed to by TPT Project Team and BTS, the Contractor may remedy defects during the maintenance/warranty period.

To note the successful Completion of Cold Commissioning, the Transnet Port Terminals Senior Project Manager will prepare a Cold Commissioning Certificate (accompanied by a categorised Punch List). By signing the Cold Commissioning Certificate, the Contract Works are accepted by the Project Team for Care, Custody and Control and the Client becomes the "User" in terms of the OHS ACT but note (This is a Provisional TCC subject to successful Endurance Test; the 12 month warranty period would start after the endurance test).

7.3 Stage 3 – Hot Commissioning (System Integration and Load Tests)

This stage of Commissioning consists of placing the Works into operation by BTS with the assistance of TPT projects, Contractors and Equipment Suppliers, using the operating and maintenance personnel of BTS. Hot Commissioning includes performance testing of the Works in terms of the Contract.

a) Set-up and Tuning of system Parameters

During this phase, material, iron ore, will be introduced into the system to allow the Client with the assistance of TPT Projects to set system parameters and perform the necessary tuning.

b) Production build-up

Production build-up entails the verification of quality, process and reliability parameters during production cycles while production levels are increased to prepare for performance testing.

c) Acceptance/Performance Testing, Endurance Testing

After successful completion of commissioning, the equipment shall be subjected to acceptance testing, i.e. actual operation conditions.

The purpose of this test is to prove that the Plant operates under maximum expected operating conditions and that the safety and other mechanisms repeatedly operate as required and that the Plant is structurally and mechanically sound and ready for full operation.

Acceptance testing will comprise of a minimum of 40 hours endurance test (either continuous or consecutive sessions), of which the last 32 hours must be a completely trouble-free operation to the satisfaction of the Project Manager. If the operation is not trouble free, Endurance Testing will continue until the EQUIPMENT operates for 32 hours trouble free before the Endurance Testing can be deemed complete.

During this endurance test (the first 20 hours of the 40 hours), should there be any interruptions due to trips, faults etc., which can be reset in less than 1 hour, the test will continue. If, however it takes longer than 1 hour to get the Plant operational then the endurance testing hours will be reset zero.

During endurance testing, the Contractor must compile a register of faults, stoppages and test results indicating Date, Shift, Operator, Time, Duration and Description of the problem.

During acceptance testing the Plant will be operated by the Employer's operators, but the Contractor shall provide at his own cost the personnel and all equipment necessary for acceptance testing, including a sufficient number of suitably qualified people to assist the Employer's Plant operators for the duration of acceptance testing.

To note the successful completion of Hot Commissioning, the TPT Senior Project Manager will issue a Completion Certificate for Design, Supply and Installation. Contractors will undertake to complete all outstanding punch list work during the maintenance/warranty period and by an agreed date

8. PUNCH LISTING

a) Mechanical Completion Punch List

When in the opinion of the Contractor, the Works or part of the Works is sufficiently complete to warrant the commencement of Cold Commissioning of such Works, the Contractor will submit a request for a joint Mechanical Completion Punch list inspection, after having punched the works himself and cleared all Category 'A' and 'B' Punch list Items. Any additional Category 'A' Punch list Items identified by the Transnet Port Project team and BTS must be rectified before proceeding to the next stage. Once all Category A Punch List Items have been rectified a Mechanical Completion Certificate/Ready for Commissioning Certificate (RFC) will be issued to the Contractor.

For part of the structural contracts, a Construction Completion Certificate will be issued at this point. It is at this point that the Construction Manager handed over the completed project to the Commissioning Manager to proceed with the commissioning process.

The Construction Manager will be responsible to ensure that all construction related punch list items, that hinder the Commissioning Process, are cleared and completed before signing-over the Construction Completion Certificate to the Commissioning Manager.

Note: Mechanical Completion also means Electrical, Instrumentation and Control Completion where relevant.

b) Cold Commissioning Verification

Any functional defects/deficiencies identified during Cold Commissioning will be registered in the Deficiency Management Database for rectification and closeout.

When the Works has been Cold Commissioned, the Contractor will submit a request for a joint Cold Commissioning Punch list inspection to verify that all Category 'A' and 'B' punch items are completed and to ensure that any damaged plant or equipment are repaired prior to the issue of a Cold Commissioning Certificate.

For installation only contracts, a Completion Certificate must be issued at this point.

c) Hot Commissioning Verification

Any functional defects/deficiencies observed during Hot Commissioning will be recorded in the Deficiency Management Database for rectification and close out.

As soon as the *Contract Works* have successfully passed all applicable performance tests in accordance with the conditions of the relevant contract and upon completion of Hot Commissioning, TPT Project Manager and the Client verify that all functional defects/deficiencies recorded in the Deficiency Management Database have been investigated, resolved and closed out have been signed off.

For supply and install contracts a Completion Certificate will be prepared by the TPT Project Manager for acceptance by the Client.

d) Punch List Categories

Punch list items will be categorised into Category 'A', 'B' or 'C' punch items.

e) Punch List Register

All Punch lists must be registered with the Commissioning Manager who will maintain a Register of Punch list items in the Commissioning Database for follow-up and close out.

The Commissioning Manager will be responsible to ensure that all Commissioning Punch list Items are cleared and completed by the agreed date.

When items on the punch lists are cleared, the Commissioning Manager will ensure that the punch list register in the Commissioning Database is updated to reflect the status of punch list completion.

f) Functional Defects

Functional defects and deficiencies identified during the Commissioning and Maintenance phases will be recorded by the Commissioning Manager in the Deficiency Management Database and handed over to the responsible Contractor and/or TPT Projects for clearance.

8.1 Equipment Modifications

Any modifications required by the Client to any equipment, plant or control, should be identified before the commissioning process commences.

These Modifications to be identified during the construction/refurbishment phase of the project and managed according to the Change Control Procedure.

All proposed/required modifications shall be presented in writing, by the Client, in time not to delay the project commissioning phase, approved and logged in the change register.

If it is a Process change then a re-HAZOP must be carried out prior to the commencement of the work to ensure that the proposed process change is safe to implement.

Once the scope of the modification is finalised, the TPT Project Manager will examine and evaluate time and cost implications. Allocation of funds if required will be approved in accordance with TPT - Change Control Procedure prior to implementation of the change.

Requests for changes are not Punch List Items and must be logged and controlled outside the Punch List Process.

All requests for plant modification or comments from the Client's operating personnel must be channelled through the TPT Project Manager and TPT Construction Manager for review and approval, before the Commissioning Phase.

8.2 Safety Clearance Inspection

It is the responsibility of the Contractor to prepare the Works for Safety Clearance Inspections. The purpose of the Safety Clearance Inspection and Certificate is as follows:

- To ensure that the plant in question is safe to be energised from a mechanical, electrical and process perspective
- To ensure that the surrounding environment is conducive to safe operating practises i.e. no debris lying around, all trenches covered, barricades are installed, fire extinguishers available etc.

Any Health and Safety requirements identified during Punch listing must be rectified before the issue of a Safety Clearance Certificate.

When the prerequisites as defined above have been met, a Safety Clearance Certificate can be issued. Once the Safety Clearance Certificate has been signed the plant **MUST** be energised.

If for some reason the plant cannot be energised at that time, the process must be repeated just prior to the plant being energised.

After the issue of a Safety Clearance Certificate, plant can only be worked on under permit issued by an Appointed Person of the defined "User", in terms of the OHS Act to a Responsible Person (Refer to The Permit to Work Procedure). A copy of the Safety Clearance Certificate must, upon completion, be forwarded to the relevant Commissioning Manager. The responsible Commissioning Team will organise and co-ordinate these inspections and will only issue a Safety Clearance Certificate when the plant is safe to be energised. To ensure total safe working conditions, a series of checks and tests shall be made involving all disciplines, to establish the status of each piece of equipment. These checks and tests will include but are not limited to:

- Lubrication
- Alignment
- Rotation
- Power supply available and adequate
- Electrical equipment, safety checks and interface controls already checked out
- All safety precautions in effect; and
- What other equipment will also run and whether it was checked and declared safe via a Safety Clearance Certificate.

When tests and/or checks are to be carried out to demonstrate Mechanical Completion that involves the application of energy, such as megger testing of cables, a safe working procedure must be developed by the Contractors and demonstrated to the Commissioning Manager.

Prior to such tests or checks, a safety walk down of the equipment to be tested will be carried out by the Commissioning Manager and Commissioning Teams to ensure that the area is made safe, barricaded or demarcated, locked out where required, relevant danger signs attached and that only persons directly involved in such testing are allowed inside the demarcated area while testing is in progress.

The Commissioning Manager must inform all parties working in the immediate vicinity of such tests and of the dangers associated with the testing.

To provide a record of inspection and checks, to ensure the safety of all involved and to facilitate a systematic check out, a system of tags shall be used together with the Permit to Work system. These tags shall be sequentially numbered to facilitate a tracking system related to responsibility for safety. The issue and control of tags will be the responsibility

The Contractor shall arrange for visits by the relevant authority, provide all personnel and equipment necessary to conduct the tests as required and hand over to the Commissioning

Manager the documents and certificates of the approved equipment. The relevant Commissioning Team shall be present during tests for verification and acceptance as identified on the relevant Commissioning Plan (Hold and Witness Points). The unit/module/system to be energised will be locked out and tagged in accordance with the agreed lock out and tagging procedure as described in the BTS "Safe Lock-out Procedure".

8.3 Statutory Certification and Approvals

The Contractor shall obtain from the applicable authorities, all necessary certification and approvals for equipment in his scope of supply. Approvals are typically required for:

- EC&I infrastructure supplied
- Cranes and other lifting equipment
- Hydraulic Systems and other pressure vessels
- All other equipment listed by legislation

The Statutory Certifications and approvals shall be included in the Contractor's Safety file. To be checked and accepted by the Construction Manager and will form part of the Mechanical Completion/Ready for Commissioning Certificate (RFC) to be handed over to the Commissioning Manager.

8.4 Verification of Commissioning Activities

a) Commissioning Quality Control Plan (QCP)

The Commissioning Manager assisted by the Site QA/QC Coordinator prior to any commissioning activities taking place must develop a Master Commissioning QCP.

The following Commissioning QCP's need to be developed by TPT together with the Contractors and approved by Client/BTS prior to any commissioning activities taking place.

- Cold Commissioning QCP
- Hot Commissioning QCP
- Test and Evaluation QCP for Acceptance/Performance Testing

b) Commissioning Inspections

TPT Projects shall ensure that, prior to Commissioning QCP approval, the Contractor has broken down their Commissioning QCP to include adequate inspections and checks for each piece of equipment.

TPT Projects shall ensure that the Contractor's Commissioning QCP's make reference to relevant forms and check lists that will be required.

The Commissioning Team that includes Contractor's representatives and shall be recorded on the relevant forms and check sheets shall conduct commissioning inspections.

When the Commissioning Team for that specific unit/module/system is satisfied that Commissioning has been done correctly the Commissioning QCP shall be signed off.

c) Testing and Trials

Commissioning will only be considered complete when the Commissioning Team is satisfied that all necessary tests have been correctly completed and that the recorded data confirms that the relevant equipment or system is ready for the next Commissioning stage.

8.5 Care, Custody and Control

After Hot Commissioning, the Hot Commissioned system will be transferred to the Care, Custody and Control of the Client. The transfer is formalised only when the Client signs the Hot Commissioning Certificate.

TPT Projects Senior Project Manager will prepare the Hot Commissioning Certificate for signature by the relevant parties.

Defects Correction/Defects Liability/Warranty Period

All Categories 'C' Punch list items as well as defects occurring during the Defects Correction/Defects Liability/Warranty Period must be closed out before the expiry of the Maintenance/Warranty Period.

To facilitate the administration of the guarantees, all defects and/or repair work during the Defects Correction/Defects Liability/Warranty Period must be logged in the Deficiency Management Database.

The reporting of such defects/deficiencies is the responsibility of the Operating and Maintenance Staff. It is the responsibility of the TPT Project Manager in conjunction with the relevant Contractor, to determine whether such defects and deficiencies are the responsibility of the Contractor and should expedite the rectification of such defects and deficiencies.

8.6 Spares

The Principal Contractor and BTS shall be jointly responsible for provide critical spares for the SR3, at the Bulk Terminal Saldanha, quantified and as agreed between the parties, as detailed in the engineering reports (Z.5200160-ER) and Procurement Report (Z.5200160-PR). The technical performance specifications shall be submitted to the Project Team for approval prior to delivery.

9. ORGANISATION

The Contractor will be responsible for the planning of the commissioning together with the TPT Project Team well ahead of the commissioning phase meaning this document shall be revised and a detailed plan submitted for updates and comprehensive commissioning plan to address any commissioning loopholes if noted.

10. COMMISSIONING SCHEDULE

The Principal Contractor to provide a detailed commissioning schedule during the commissioning planning phase to be approved by the Project Team. This schedule to be aligned to the overall project schedule and the Cold & Hot Commissioning specifications mentioned in this document.

11. SAFETY

In addition to complying with applicable statutory health and safety requirements, the Contractor shall comply with TPT safety regulations and guidelines.

The Project Team shall provide the Principal Contractor with copies of the TPT safety, health, environmental, quality and risk documents, and the relevant updates thereof from time to time.

Commissioning staff will be required to attend the Transnet safety inductions, site-/task specific training and medical checks. Such staff must ensure that they are aware of normal operational- and other construction activities during the commissioning period. Appropriate safety equipment must be used.

All equipment is to be fully and properly commissioned without the bypassing of any safety systems or safety equipment. The designed processes, electrical-, instrumentation and control procedures to be adhered to. Where such bypassing is unavoidably necessary for commissioning purposes, even if detailed in the commissioning procedure, it will not be done without the written approval of the appointed responsible Engineer from BTS, on

evaluating of the written recommendation from the Commissioning Manager. Commissioning will take place in a set sequence. This will be strictly adhered to so that staff will not be expected to work in an unsafe environment or unduly long hours.

A policy of "Zero Tolerance" will be strictly adhered to and it will be the responsibility of the Commissioning Manager to ensure this is the case.

12. HAND-OVER PROCEDURES

The following data-packs, properly documented and filed both in Hard and Soft copies, would be required before handover of the Plant:

- All Structural Material Test Certificates
- Corrosion Protection Dry Film Thickness tests
- Alignment verification results
- Inspection reports
- Red Lining of Manufacturing drawings if applicable
- Signed off all commissioning certificates together with completed punch lists
- Required statutory documents upon receipt of complete documentation a Hand Over certificate to be signed by TPT.

12.1 Red Lining" of Commissioning Drawings

During Commissioning, all authorized changes to drawings, (such as P&ID's, Loop Diagrams, Control Circuits, Cable Schedules, O&M Manuals, etc.), will be marked up in RED on the set of Commissioning Drawings and Manuals.

Authorization to affect changes to Documentation will be done in accordance with the Technical Query Work Instruction.

Upon final completion of the update to the drawings, the status will be classed as "As Built" and the drawings will be revised to the next revision and issued to the Client.

12.2 Training and Manning

All personnel involved in Commissioning must be appropriately trained. This will require the recruitment or transfer of personnel in sufficient time for training to take place (This project will not require major training as it is a refurbishment of the existing plant equipment, but if there is any form of training required, the operational readiness report will detail the training information).

The Transnet Port Terminals Commissioning Manager must ensure that all staff involved in commissioning activities is familiar with the plant to be commissioned. It is Transnet Port Terminals responsibility, supported by its Contractors to provide trained personnel during Cold Commissioning. However, Client Operating staff should make use of this period to familiarize themselves with the plant, well in advance for training by BTS where specialist training in terms of the Contract is required.

Manning schedules must be prepared in good time for control purposes.

12.3 Contractual Certification

To note; the successful completion of identified stages of the Contract Works, Contractual Certification, as detailed below is required.

12.4 Mechanical Completion Certificates

As soon as in the opinion of the Contractor, the Works has physically been completed in accordance with the drawings and specifications as detailed in the Scope and Specification of the Works and that the Works or portion thereof is ready for Cold Commissioning to commence he shall arrange for an internal punch list to take place and rectify all category 'A' and "B" Punch List Items. Once Contractor is satisfied that the plant is ready for Cold Commissioning to commence, he shall complete a request for Punch Listing and submit to the Project Team who will arrange for a formal Punch List to take place. Once it is verified that the remaining Category 'A' and 'B' Punch List items, were addressed, the Construction Manager will prepare a Mechanical Completion Certificate for Signature by the various Parties and Hand-over the completed *Works* for Commissioning to the Project Team, to commence with Cold Commissioning.

12.5 Cold Commissioning Certificates

Once Cold Commissioning is complete with no remaining Category 'A' and 'B' punch items, the relevant Contractor must request the issuance of a Cold Commissioning Certificate.

The Commissioning Manager will, when requested by the Construction Manager, certify that Category 'A' and 'B' punch items have been signed off and that Contractor has agreed in writing to rectify any remaining deficiencies during the Defects Correction/Defects Liability/Warranty Period within 30 days, except for new defects.

12.6 Completion Certificates

As soon as the *Works* have successfully passed any required Performance/Acceptance Test with only Category 'C' Punch List Items remaining with a commitment to complete the Category 'C' Punch List Items by an agreed date during the Defects Correction/Warranty Period and following the application by Contractor for a Completion Certificate, a Completion Certificate will be issued.

12.7 Final Certificates

On expiry of the Defects Correction/Defects Liability/Warranty Period and once all punch list items, defects reported during the maintenance/warranty period and commercial issues are successfully resolved, Transnet Capital Projects shall arrange with Client to issue a Final Certificate to Contractor.

All punch list items, functional defects and deficiencies must be cleared before the issue of a Final Certificate.

13. RECORDS

All records generated in accordance with the requirements of this procedure retained in accordance with the requirements of: Archiving and Retention of Documents and signed over to the Client.

14. ANNEXURES

Annexure 1 – Commissioning Responsibility Matrix

COMMISSIONING PHASE	Principal Contractor				TPT Project Team		
	CONSTRUCTION MANAGER	COMMISSIONING MANAGER	ENGINEER	CONTRACTOR OR SUPPLIER	TPT	ENGINEERING AND MAINTENANCE	OPERATIONS
CONSTRUCTION							
Safety	A		I/V	R			
Planning	A		I/V	R			
Supervision	A		I/V	R			
Installation	A		A	R			
Quality/OCP	A		A	R		v	
CHECKOUT ACCEPTANCE							
Safety	I	R/A	I/V	I			
Planning	I	RIA	I/V	I			
Supervision	I	R/A	I/V	I			
Contractor Equipment Inspections & Punch Listing	I	R/A	v	I			
Check Construction in accordance with design/specification	V/A	A	R/A	I	v	v	v
Punch Listing	V/A	R/A	I/A	I	v	I	V/A
Check out Acceptance Certificate	V/A	R/A	A			A	A
STAGE 1:PRE-COMMISSIONING							
Safety	I	R	I/V	I	I		I
Planning	I	R/A	I/V	I	I		I
Equipment Inspection & Testing	I	RIA	I/V	I	v	v	v
Check construction in accordance with design /specification	I	v	R/A		v	v	v
Check Lists	A	R/A	I/A	I	v	v	V/A
Taking Over Certificate (Install Contractors)	A	R/A	A			A	A



COMMISSIONING PHASE	Principal Contractor				TPT Project Team		
	CONSTRUCTION MANAGER	COMMISSIONING MANAGER	ENGINEER	CONTRACTOR OR SUPPLIER	TPT	ENGINEERING AND MAINTENANCE	OPERATIONS
STAGE 2: COLD COMMISSIONING							
Safety	I	R	I/V	I	I		I
Planning	I	R		note 2	Note 1		Note
Check construction in accordance with design/spec.	I	v	R/A		v	v	v
System Inspection & Testing	I	R/A	I/V	I	v	v	v
Overall Systems Integration	I	R/A	I/V	note 2	v	v	v
Check Lists	I	R/A	I/A	note 2	v	v	V/A
Issue Commissioning Handover Packs	I	R/A	V/A		A	A	A
T.C.C		R/A	A			A	A
STAGE 3: HOT COMMISSIONING							
Safety					I	R	R
Planning					I	R	R
Check performance to specification	s	s	s		R	I	I
1st (example) tap		s	s		R	I	I
T.C.C.C		R	v		I	A	A
PRODUCTION & OPTIMISATION							
Safety						R	R
Completion of CAT 'C' punch items	I	R	I/V	I	v	A	A



Issuing of Site de- establishment Memorandum		R	I/V		v	v	A
--	--	---	-----	--	---	---	---

R = Responsible (Actively conducting accountable activities and control over others involved)

I = Involved (Actively rendering accountable assistance, part of the team doing day to day activities)

V = Verify (Only doing spot checks I verification)

S = Support (There to give support where required)

A = Approve

Note 1 = Where applicable

Note 2 = Where applicable



Annexure 2 – Commissioning File Contents

CONTRACTOR:		CONTRACT NO:			
NO	ITEM	DOCUMENT	CONTR.	DOCUMENT SIGN-OFF	
				TPT PROJECT TEAM	BTS
A	GENERAL				
01	Module Description				
02	Baseline Schedule Updated				
03	Commissioning Team				
B	MECHANICAL COMPLETION				
04	Module Data Books/Construction Work Packages				
OS	Request for Mechanical Completion Punch Lists				
06	Contractor/ TPT/CLIENT categorized				
07	Loop Checks and other required Electrical Check Certificates.				
c	COLD COMMISSIONING				
08	Manuals & Instructions				
09	List of Commissioning/Maintenance Spares and Tools & Report of Availability				
10	Safe Working Procedures				
11	Lubrication Schedule				
12	Request for Safety Clearance Inspection				
13	Cold Commissioning QCP and Check lists, Functional Specification, Data Sheets and P&ID's, Tagged Equipment List Single Line Diagrams				
14	Safety Clearance Certificate				
15	Request for Cold Commissioning Certificate				
16	Cold Commissioning Defects/Deficiency List				
17	Cold Commissioning Certificate				
D	HOT COMMISSIONING				
18	Hot Commissioning QCP & Checklists				
19	Hot Commissioning Defects/Deficiency List				
E	PERFORMANCE TESTING				
20	Performance Trial Notification				
21	Notification to Specialized Equipment				
22	Notice of Acceptance/Rejection				
23	Performance Test Requirements &				
24	Request for Completion Certificate				
25	Completion Certificate				
F	CLOSE-OUT				
26	Training Requirements and Reports				
27	Test Requirements & Certificates				



28	As-built Drawings				
29	Subcontractor's Document Register				
30	Final Certificate				
G	OTHER				
31	Index of Unit Packages & Locations				
32	Register of Unit Packages for Sign-out				



Annexure 3 - Mechanical and Electrical Completion Certificate/Ready for Commissioning Certificate (RFC). Completion of Construction

M & E Completion Certificate No.			
Date:		Originator:	
Project Name:		TPT Project Manager:	
Contract No:		Contractor/Supplier:	
Contract Description:			
System/ Equipment:			
Defects List items outstanding?	Yes <input type="checkbox"/>	No <input type="checkbox"/>	If yes, attach Defects List to this certificate
NOTE: 1.Category "A" and "B" Defects MUST be rectified prior to approval of this certificate 2.Defects List Item Nos.			
<p>It is hereby certified that the Installation of Equipment defined above has been successfully Inspected. Tested, Rectified as noted above, and is released for the "Cold Commissioning" stage of the work and that the attached Defects shall be rectified by the stipulated due dates. This release in no manner relieves the Contractor and/or his sub-contractors and/or Suppliers of his Contractual obligations in terms of the Contract, and/or warranty, and/or performance guarantee. It is the Contractor's obligation to ensure that the Installation of Equipment is safe in terms of the OHS Act of South Africa to progress into the "Cold Commissioning" stage of the work. The Designer hereby declares that the Installation of the Equipment defined above is safe to use in terms of the OHS Act of South Africa and is ready to be energized and used for "Cold Commissioning" purposes.</p>			
DESIGNATION	NAME	DATE	SIGNATURE
Principal Contractor			
ECM Project Manager			
ECM Quality Manager			
TPT Project Manager			



Annexure 4 - Completion of Cold Commissioning Certificate

CC Certificate No.			
Date:		Originator:	
Project Name:		TPT Project Manager:	
Contract No:		Contractor/Supplier:	
Contract Description:			
System/Equipment:			
Comments:			
Defects List items outstanding?	Yes <input type="checkbox"/>	No <input type="checkbox"/>	If yes, attach Defects List to this certificate
NOTE: Category "B" Defects MUST be rectified prior to approval of this certificate			
2. Defects List Item Nos.:			
It is hereby certified that the System and Equipment defined above has been successfully "Cold Commissioned", Rectified as noted above and is released for the "Hot Commissioning" stage of the work and that the attached Defects shall be rectified by the stipulated due dates.			
This release in no manner relieves the Contractor and/or his sub-contractors and/or Suppliers of his Contractual obligations in terms of the Contract, and/or warranty, and/or performance guarantee. The Employer hereby accepts in good faith the above referenced System and Equipment for "Hot Commissioning".			
The Designer hereby declares that the Installation of the Equipment defined above is safe to use in terms of the OHS Act of South Africa and is ready to be energized and used for "Hot Commissioning" purposes.			
DESIGNATION	NAME	DATE	SIGNATURE
Principal Contractor			
ECM Project Manager			
ECM Quality Manager			
TPT Project Manager			



Annexure 5 - Completion/Take-over Certificate

COMPLETION OF HOT COMMISSIONING AND SUCCESSFUL 40 HOUR ENDURANCE TEST

HC Certificate No.			
Date:		Originator:	
Project Name:		TPT Project Manager:	
Contract No:		Contractor/Supplier.	
Contract Description:			
System/Equipment:			
Comments:			
Defects List items outstanding?	Yes <input type="checkbox"/>	No <input type="checkbox"/>	If yes, attach Defects List to this certificate
<p>NOTE: 1. Category "B" Defects MUST be rectified prior to approval of this certificate 2. Defects List Item Nos.: See list attached if applicable.</p> <p>It is hereby certified that the System and Equipment defined above has been successfully "Hot Commissioned", Rectified as noted above and is hereby taken over by the Client and that the attached Defects shall be rectified by the stipulated due dates.</p> <p>This release in no manner relieves the Contractor and/or his sub-contractors and/or Suppliers of his Contractual obligations in terms of the Contract, and/or warranty, and/or performance guarantee. The Employer hereby accepts in good faith the above referenced System and Equipment.</p> <p>The Designer hereby declares that the Installation of the Equipment defined above is safe to use in terms of the OHS Act of South Africa</p> <p>The Contract Defects Liability starts as per the date stated below.</p>			
DESIGNATION	NAME	DATE	SIGNATURE
Principal Contractor			
ECM Project Manager			
ECM Quality Manager			
BTS Eng. Manager			
TPT Operations Manager			
TPT Project Manager			

Annexure 6 – Commissioning Team

Typical Commissioning Team Resource Diagram

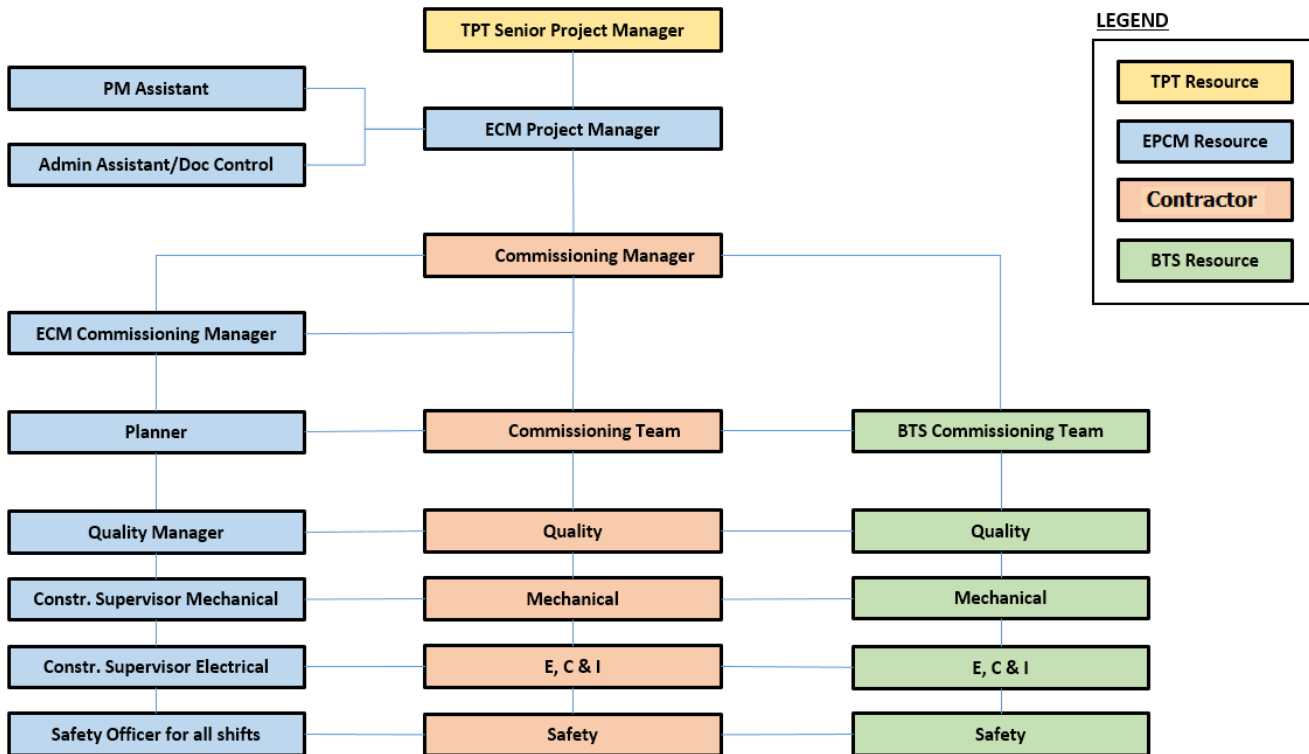

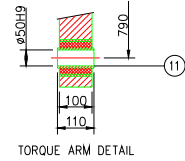
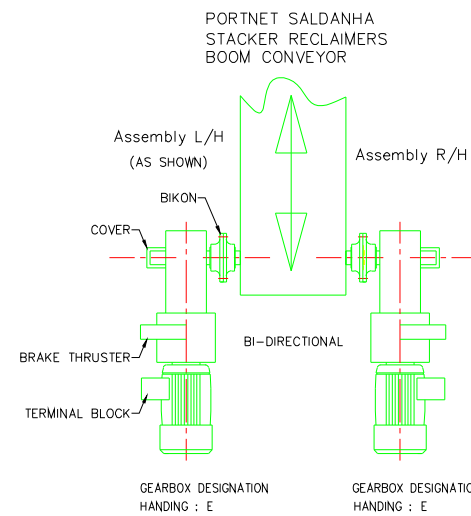
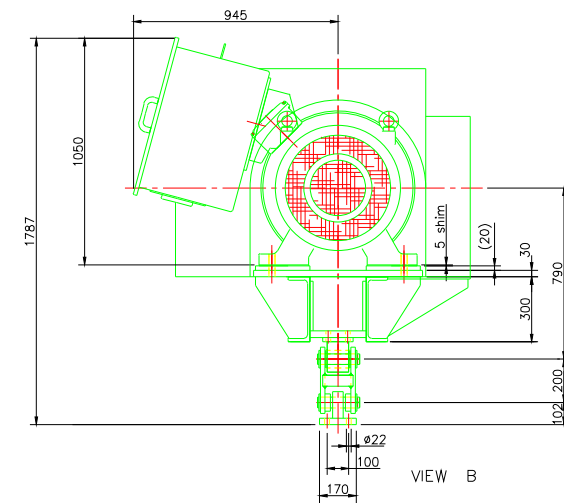
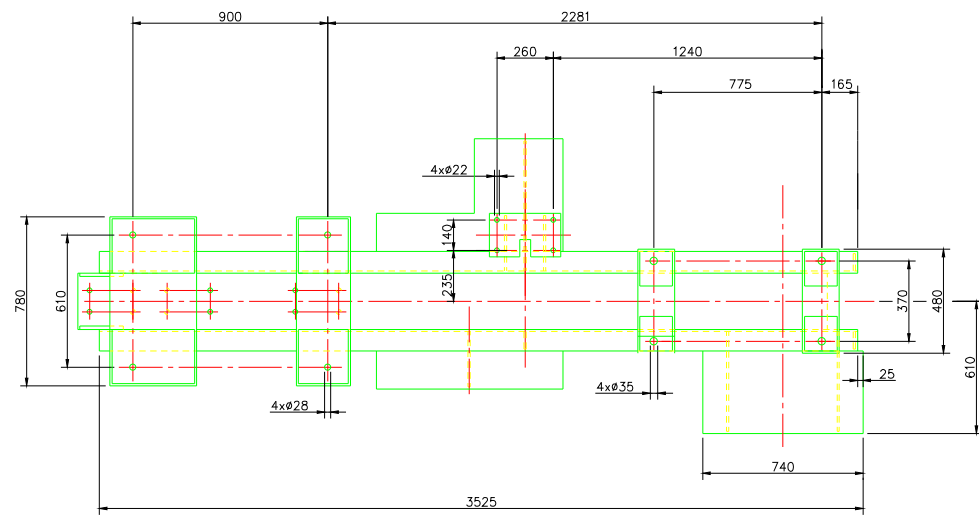
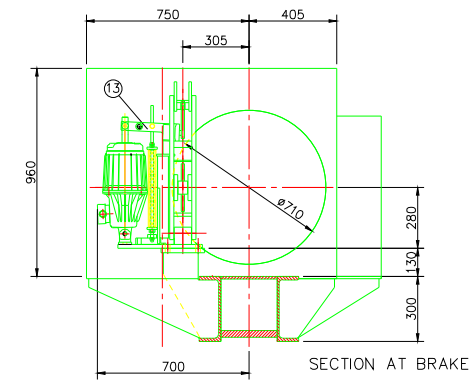
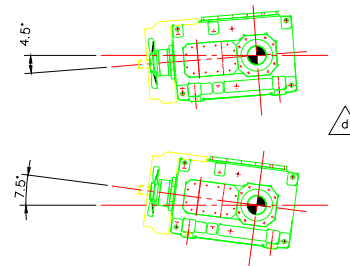
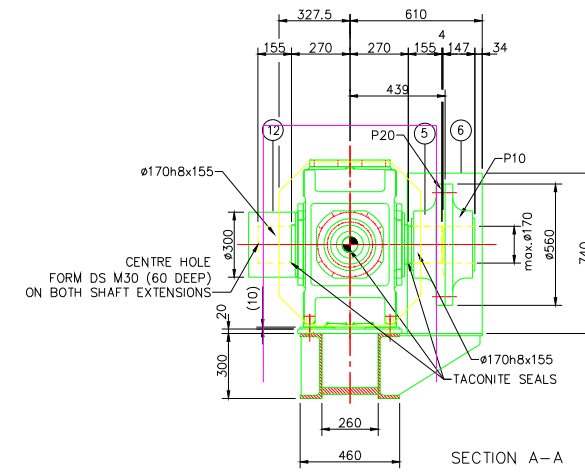
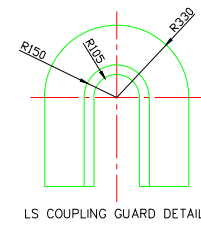
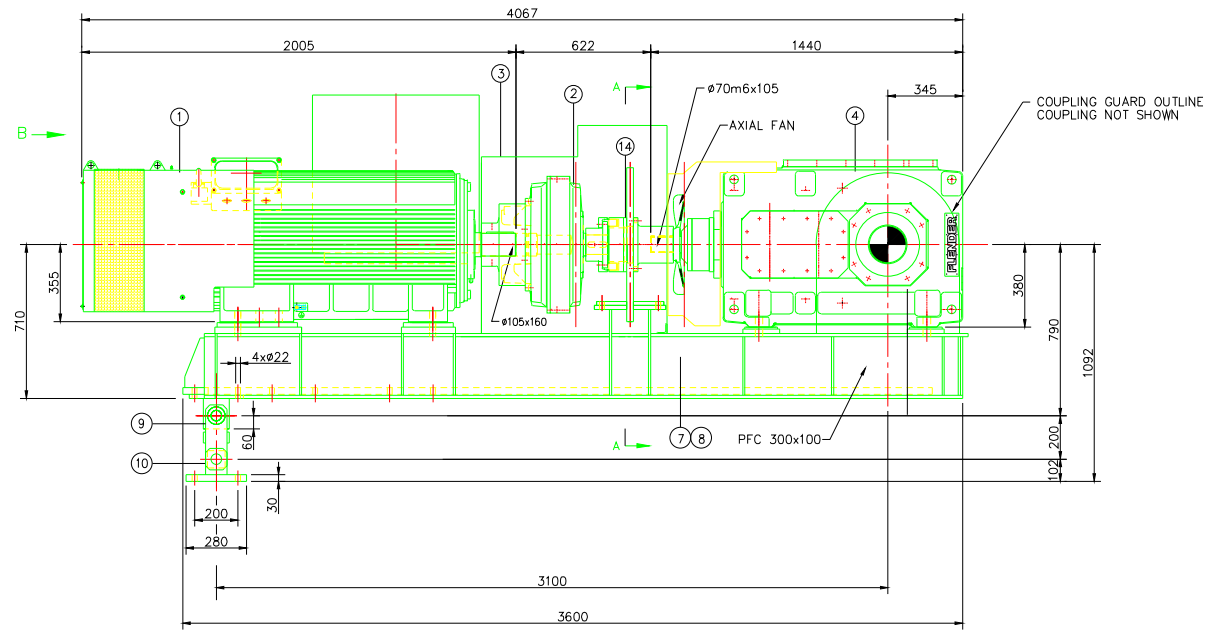

FLENDER SA DRAWING No.:
A0 A02110 d

DO NOT SCALE
IF IN DOUBT - ASK

SOUTH AFRICAN PORT OPERATIONS
IRON ORE TERMINAL - SALDANHA
STACKER RECLAIMER CONTRACT HQH375
SANCTION No. SB01 D1



METSD MINERALS (UK Ltd)
BULK MATERIALS HANDLING BRISTOL
PO BOX 821 ASHTON VALE RD
BRISTOL BS99 5ZB ENGLAND

UNLESS OTHERWISE SPECIFIED IDENTIFY THE ITEM WITH THE DRAWING NUMBER AND ISSUE LEVEL AT AND IN THE MANNER SHOWN FOR PAINTING AND FOR LUBRICATION SPECIFICATIONS SEE COMPONENTS LIST

DRAWN TO BS 8888
WELD SYMBOLS TO BSEN 22553
SURFACE TEXTURE TO BS 1134
MATERIAL & CONDITION BEFORE MANUFACTURE

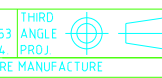

UNLESS OTHERWISE STATED DIMENSIONS ARE IN MILLIMETRES
TOLERANCES UNLESS OTHERWISE STATED (PLUS OR MINUS)

MATL
SPEC

TITLE
BOOM CONVEYOR

ITEM	QTY	DESCRIPTION	REMARKS	MASS (kg)
14	1	SPACER	Drq. SP0049	-
13	1	DISC BRAKE	CL 20 THRUSTER EB 150 Ø710	255
12	1	TOP HAT	Drq No: G010B2	-
11	1	METALASTIC BUSH	REF. No: 0 118 095	-
10	1	LINKAGE & LOWER BRACKET	Drq No: T00135	35
9	1	TORQUE ARM REACTION POINT	Drq No: T00021	15
8	1	BASEPLATE	Drq No: B01238 (opposite handing)	920
7	1	BASEPLATE	Drq No: B01228 (as shown)	-
6	1	LS COUPLING GUARD	Drq No: G01226	20
5	1	OUTPUT COUPLING	BIKON 30-330/140-170	210
4	1	GEAR UNIT	B3SH11 RATIO: 19,744 : 1	1575
3	1	HS COUPLING GUARD	Drq No: G01281 (both handings)	40
2	1	INPUT COUPLING	FNDB565	220
1	1	MOTOR / SIEMENS	WEG 3550 260kw 3300V 1470rpm	1800
			REMARKS	MASS (kg)

3342 O/ALL SHAFT

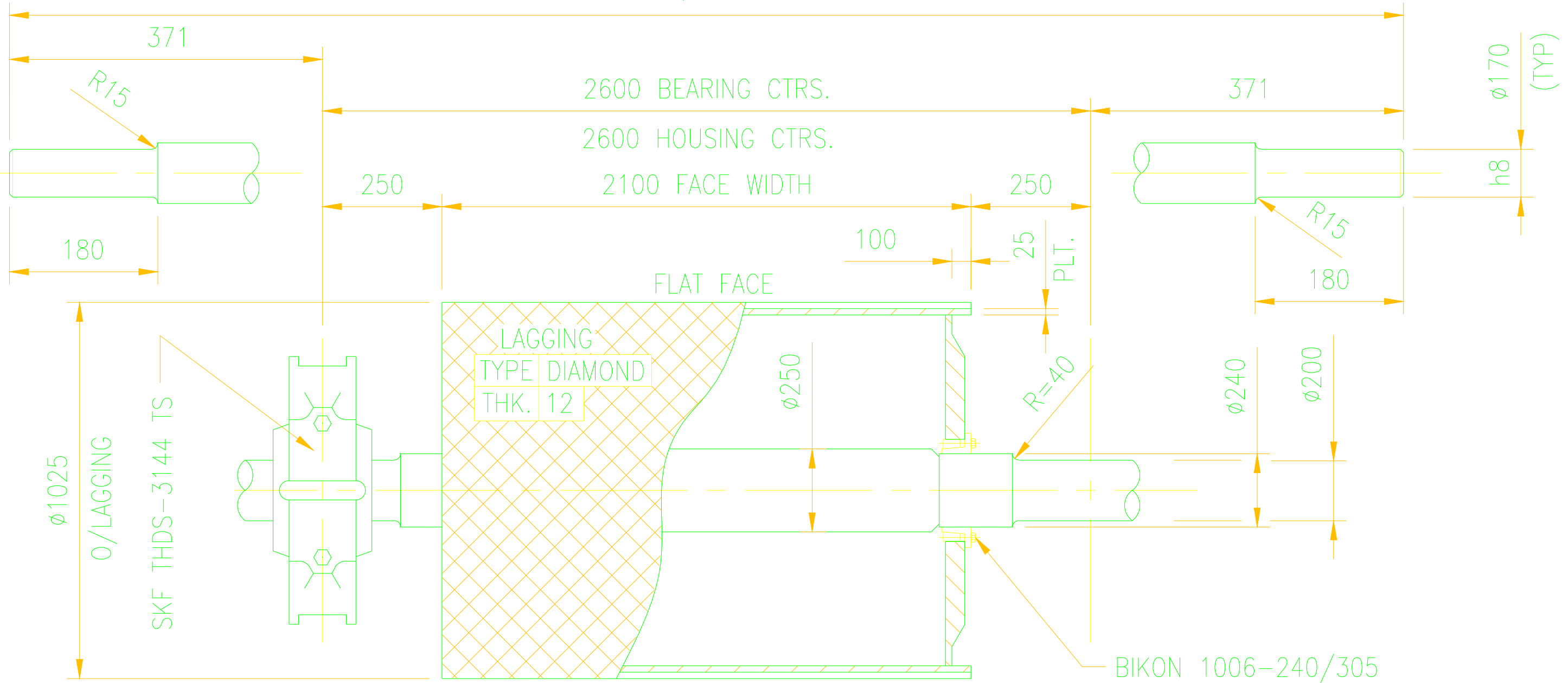

MANUFACTURED BY:
 CPM ENGINEERING (Pty) Ltd
 P.O.BOX 9695 EDENGLLEN 1613

RUNNING TENSIONS
 T1 = 252kN
 T2 = 138kN
 WRAP = 180°

BIKON 1006-240/305
 BOLT TORQUE 355 Nm

DO NOT SCALE
 IF IN DOUBT - ASK

SOUTH AFRICAN PORT OPERATIONS
 IRON ORE TERMINAL - SALDANHA
 STACKER RECLAIMER CONTRACT HQH375
 SANCTION No. SB01 D1

APPROVED FOR MANUFACTURE

UNLESS OTHERWISE SPECIFIED IDENTIFY THE ITEM WITH THE DRAWING NUMBER AND ISSUE LEVEL AT AND IN THE MANNER SHOWN. FOR PAINTING AND FOR LUBRICATION SPECIFICATIONS SEE COMPONENTS LIST.

DRAWN TO BS 8888
 WELD SYMBOLS TO BSEN 22553
 SURFACE TEXTURE TO BS 1134
 MATERIAL & CONDITION BEFORE MANUFACTURE

THIRD ANGLE PROJ

METSO MINERALS (UK Ltd)
 BULK MATERIALS HANDLING BRISTOL
 PO BOX 821 ASHTON VALE RD
 BRISTOL BS99 5ZB ENGLAND.

DRAWN R.M.	CHECKED	APPROVED
DATE 27/05/02	DATE	DATE

UNLESS OTHERWISE STATED DIMENSIONS ARE IN MILLIMETRES. TOLERANCES UNLESS OTHERWISE STATED (PLUS OR MINUS)

RANGE	MACH	FAB	CAST
0-500	0.25	2	2
501-1000	0.5	3	4
1001-2000	1.0	4	6
ABOVE 2000	2.0	6	10

NOTES 3-OFF REQ'D
 REF DRG. 701024

TITLE
 BOOM CONVEYOR
 DRIVE PULLEY
 TYPE S1-06

DRAWN	CHECKED	APPROVED
DATE	DATE	DATE

This print and all the information hereon is the property of Metso Minerals, Bulk Materials Handling Bristol and must not be made public, copied or used in any way detrimental to our interest. It is loaned subject to return on demand, unless furnished under contract provisions.

MASS 4065 kg
 ORIGINAL SCALE N.T.S.

SIZE A3	DRAWING NUMBER 188-6727-02	SHEET 1	OF 1	ISSUE 0
---------	----------------------------	---------	------	---------

3342 0/ALL SHAFT

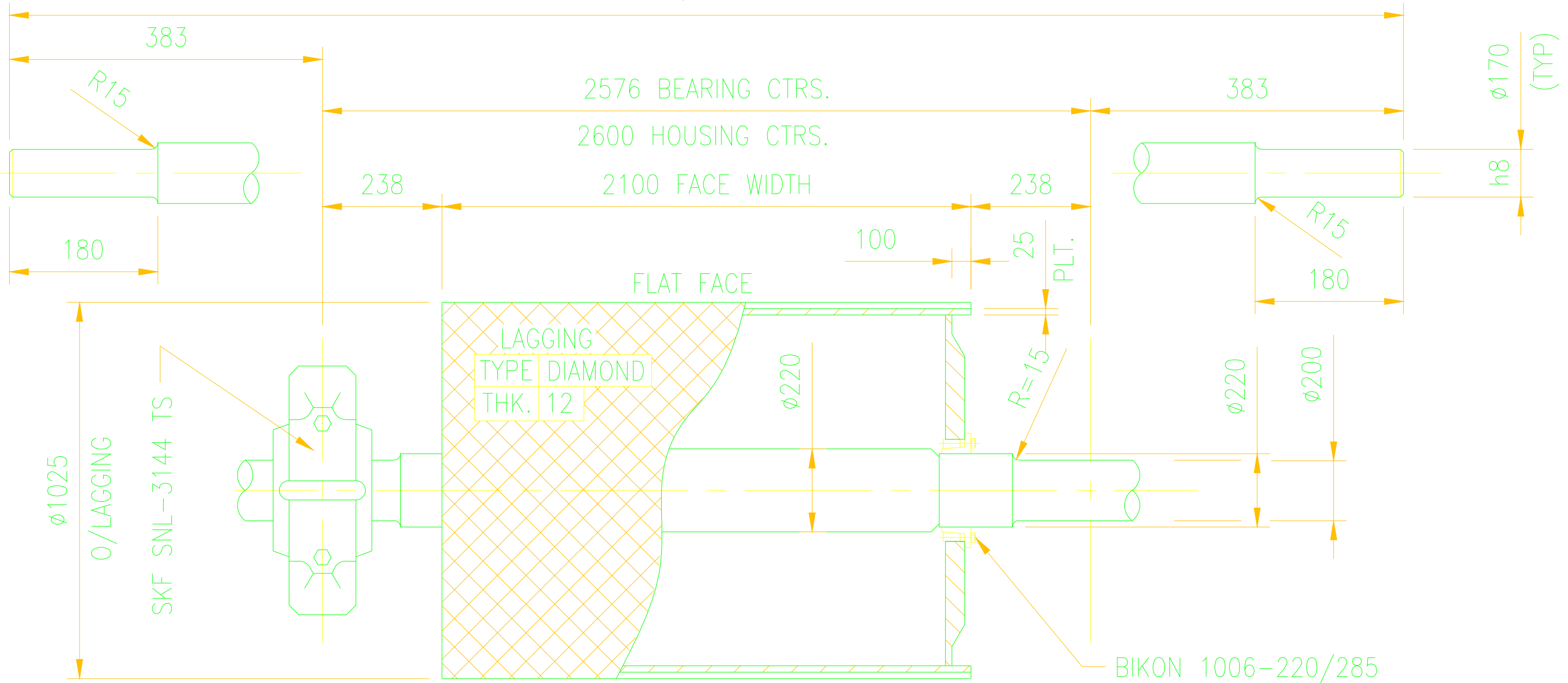

BIKON 1006-220/285
BOLT TORQUE 355 Nm

RUNNING TENSIONS
T1 = 173kN
T2 = 79kN
WRAP = 210°

MANUFACTURED BY:
CPM ENGINEERING (Pty) Ltd
P.O.BOX 9695 EDENGLLEN 1613

DO NOT SCALE
IF IN DOUBT - ASK

SOUTH AFRICAN PORT OPERATIONS
IRON ORE TERMINAL - SALDANHA
STACKER RECLAIMER CONTRACT HQH375
SANCTION No. SB01 D1

APPROVED FOR MANUFACTURE

UNLESS OTHERWISE SPECIFIED IDENTIFY THE ITEM WITH THE DRAWING NUMBER AND ISSUE LEVEL AT AND IN THE MANNER SHOWN. FOR PAINTING AND FOR LUBRICATION SPECIFICATIONS SEE COMPONENTS LIST.

DRAWN TO BS 8888
WELD SYMBOLS TO BSEN 22553
SURFACE TEXTURE TO BS 1134
MATERIAL & CONDITION BEFORE MANUFACTURE

THIRD ANGLE PROJ



METSO MINERALS (UK Ltd)
BULK MATERIALS HANDLING BRISTOL
PO BOX 821 ASHTON VALE RD
BRISTOL BS99 5ZB ENGLAND.

DRAWN R.M.	CHECKED	APPROVED
DATE 27/05/02	DATE	DATE

UNLESS OTHERWISE STATED DIMENSIONS ARE IN MILLIMETRES. TOLERANCES UNLESS OTHERWISE STATED (PLUS OR MINUS)

RANGE	MACH	FAB	CAST
0-500	0.25	2	2
501-1000	0.5	3	4
1001-2000	1.0	4	6
ABOVE 2000	2.0	6	10

NOTES 3-OFF REQ'D
REF DRG. 701024

TITLE
INCLINE CONVEYOR
DRIVE PULLEY
TYPE S1-06

DRAWN	CHECKED	APPROVED
DATE	DATE	DATE

This print and all the information hereon is the property of Metso Minerals, Bulk Materials Handling Bristol and must not be made public, copied or used in any way detrimental to our interest. It is loaned subject to return on demand, unless furnished under contract provisions.

MASS 3699 kg
ORIGINAL SCALE N.T.S.

SIZE A3	DRAWING NUMBER 188-6727-04	SHEET 1	OF 1	ISSUE 0
---------	----------------------------	---------	------	---------

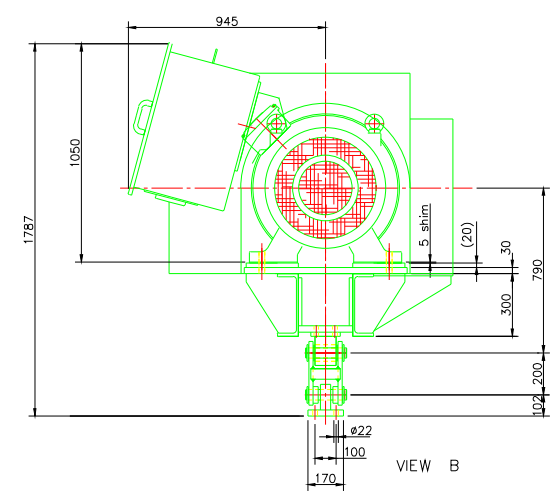
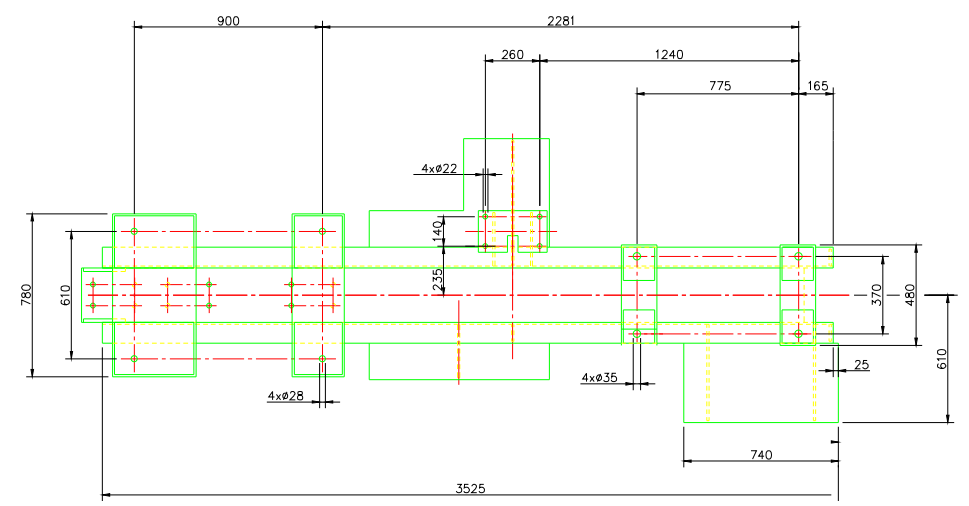
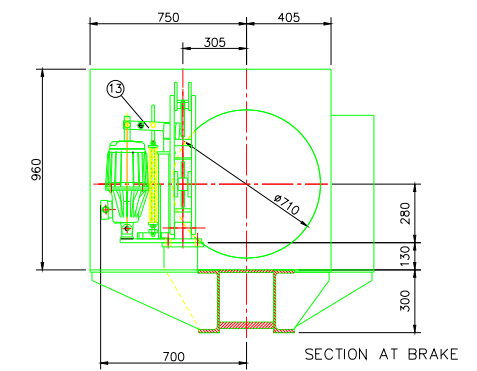
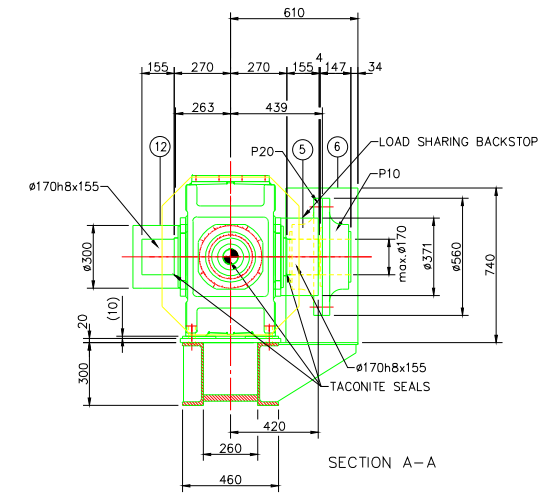
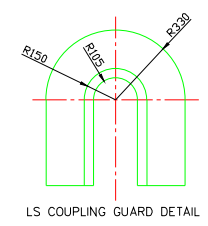
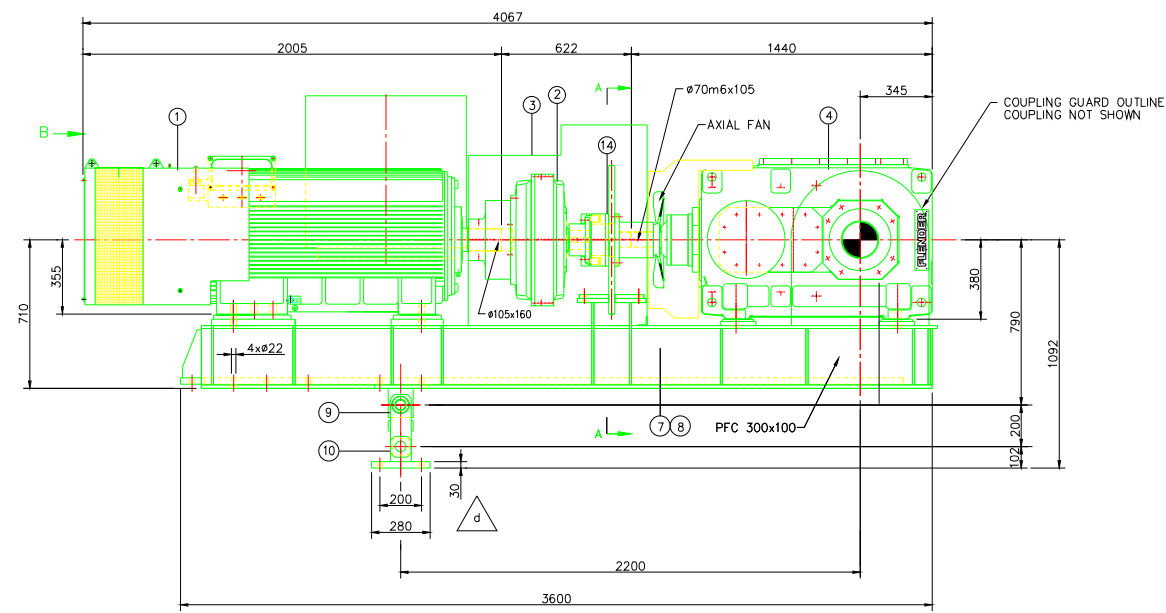

PORTNET SALDANHA
STACKER RECLAIMERS
INCLINE CONVEYOR

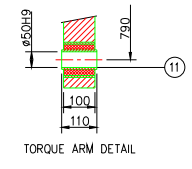
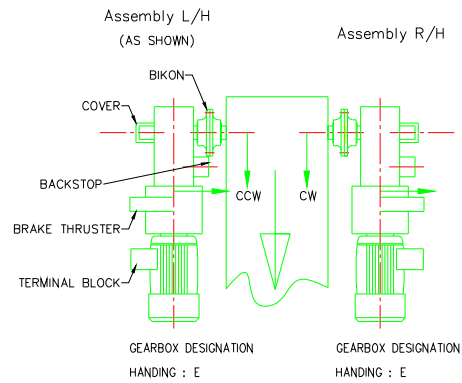

ITEM	QTY	DESCRIPTION	REMARKS	MASS (kg)
14	1	SPACER	Drg_SP0049	-
13	1	DISC BRAKE	CL 20 THRUSTER EB 150 ø710	255
12	1	TOP HAT	Drg No: G01082	-
11	1	METALASTIC BUSH	REF. No: O 118 095	-
10	1	LINKAGE & LOWER BRACKET	Drg No: T00135	35
9	1	TORQUE ARM REACTION POINT	Drg No: T00021	15
8	1	BASEPLATE	Drg No: B01238 (opposite handing)	920
7	1	BASEPLATE	Drg No: B01228 (as shown)	20
6	1	LS COUPLING GUARD	Drg No: G01226	210
5	1	OUTPUT COUPLING	BIKON 30-330/140-170	1575
4	1	GEAR UNIT	B3SH11 RATIO: 19,744 :1	40
3	1	HS COUPLING GUARD	Drg No: G01281 (both handings)	220
2	1	INPUT COUPLING	FNDB565	1800
1	1	MOTOR / SIEMENS	WEG 335D 260kw 3300V 1470rpm	-

FLENDER SA DRAWING No. :
A0 A02111 d

DO NOT SCALE
IF IN DOUBT - ASK

SOUTH AFRICAN PORT OPERATIONS
IRON ORE TERMINAL - SALDANHA
STACKER RECLAIMER CONTRACT HQH375
SANCTION No SB01 D1



METSO MINERALS (UK Ltd)
BULK MATERIALS HANDLING BRISTOL
PO BOX 821 ASHTON VALE RD
BRISTOL BS99 5ZB ENGLAND

TITLE
INCLINE CONVEYOR
DRIVE ARRANGEMENT
B3SH11 / FND565 / 355D

UNLESS OTHERWISE SPECIFIED IDENTIFY THE ITEM WITH THE DRAWING NUMBER AND ISSUE LEVEL AT AND IN THE MANNER SHOWN FOR PAINTING AND FOR LUBRICATION SPECIFICATIONS SEE COMPONENTS LIST

UNLESS OTHERWISE STATED DIMENSIONS ARE IN MILLIMETRES TOLERANCES UNLESS OTHERWISE STATED (PLUS OR MINUS)

RANGE	MACH	FAB	CAST
0-500	0.25	2	2
501-1000	0.5	3	4
1001-2000	1.0	4	6
ABOVE 2000	2.0	6	10

DRAWN TO BS 8888
WELD SYMBOLS TO BS EN 22553
SURFACE TEXTURE TO BS 1134
MATERIAL & CONDITION BEFORE MANUFACTURE

MATL

SPEC

GRADE

NOTES

DRAWN	CHECKED	APPROVED	DRAWN	CHECKED	APPROVED	DRAWN	CHECKED	APPROVED	DRAWN	CHECKED	APPROVED	DRAWN	CHECKED	APPROVED	DRAWN	CHECKED	APPROVED
DATE	DATE	DATE	DATE	DATE	DATE	DATE	DATE	DATE	DATE	DATE	DATE	DATE	DATE	DATE	DATE	DATE	DATE

This print and all the information hereon is the property of Metso Minerals, Bulk Materials Handling Bristol and must not be made public, copied or used in any way detrimental to our interest. It is loaned subject to return on demand, unless furnished under contract provisions.

MASS 5090kg	ORIGINAL SCALE 1:18	SIZE A1	DRAWING NUMBER 7*****	SHEET 1	OF 1	ISSUE A
----------------	------------------------	------------	--------------------------	------------	---------	------------

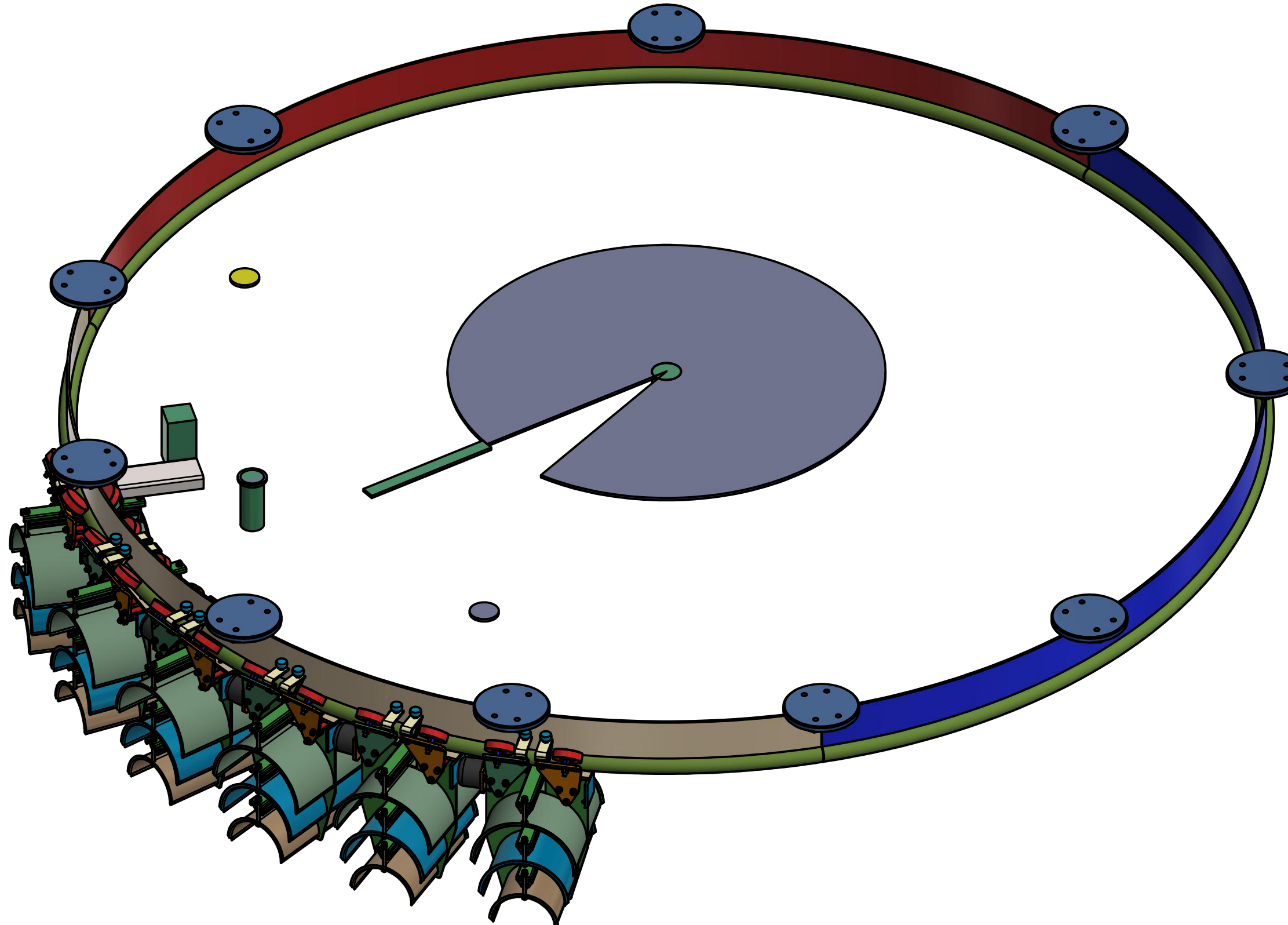

POWERMITE
 A HUDACO GROUP COMPANY

P.O. BOX 7745
 JOHANNESBURG
 2000

TELEPHONE : (011) 271-0000 (32 LINES)
 FAX : (011) 271-0235
 EMAIL : powermite.jhb@global.co.za
 INTERNET : www.powermite.co.za

Customer: Saldanha FISmidth SR02 & SR04 Round Bar Circular Festoon System

Mass: N/A	Drawing Date: 06/09/20	Stock No.: Assem-Circular4100mm-RailComp-6CabCar-SR04Circ20
Scale: ±0.2	Tolerance: ±0.2	Drawing No.: StkNo... Rev:- 00

Sheet: 1 / 5

20/09/20

THIS DRAWING IS THE PROPERTY OF POWERMITE AND IS SUBJECT TO THEIR RECALL AND MUST NOT BE REPRODUCED OR ITS CONTENTS DIVULGED WITHOUT WRITTEN PERMISSION

REV.	DATE	DESCRIPTION	BY	CHK.

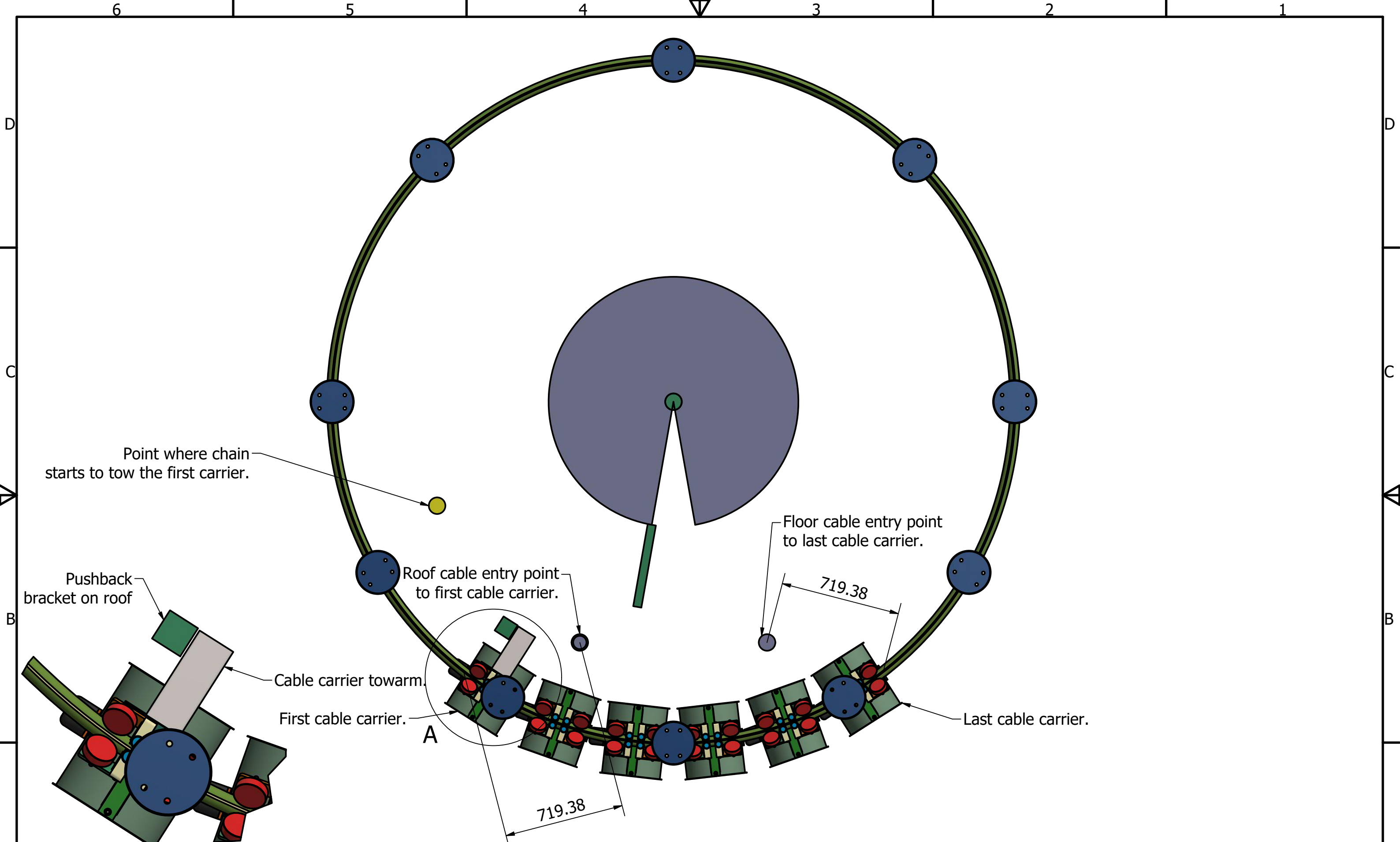

A (1 : 10)

POWERMITE A HUDACO GROUP COMPANY P.O. BOX 7745 JOHANNESBURG 2000 TELEPHONE : (011) 271-0000 (32 LINES) FAX : (011) 271-0235 EMAIL : powermite.jhb@global.co.za INTERNET : www.powermite.co.za		Customer:			Saldanha FISmidth SR02 & SR04 Round Bar Circular Festoon System	
		Mass:	Drawing Date:	Stock No.:		Assem-Circular4100mm-RailComp-6CabCar-SR04Circ20
Scale:	Tolerance:	Drawing No.:		Rev:- 00		Sheet: 2 / 5
	±0.2	StkNo...				
THIS DRAWING IS THE PROPERTY OF POWERMITE AND IS SUBJECT TO THEIR RECALL AND MUST NOT BE REPRODUCED OR ITS CONTENTS DIVULGED WITHOUT WRITTEN PERMISSION						
						A3 20/09/20

REV.	DATE	DESCRIPTION	BY	CHK.

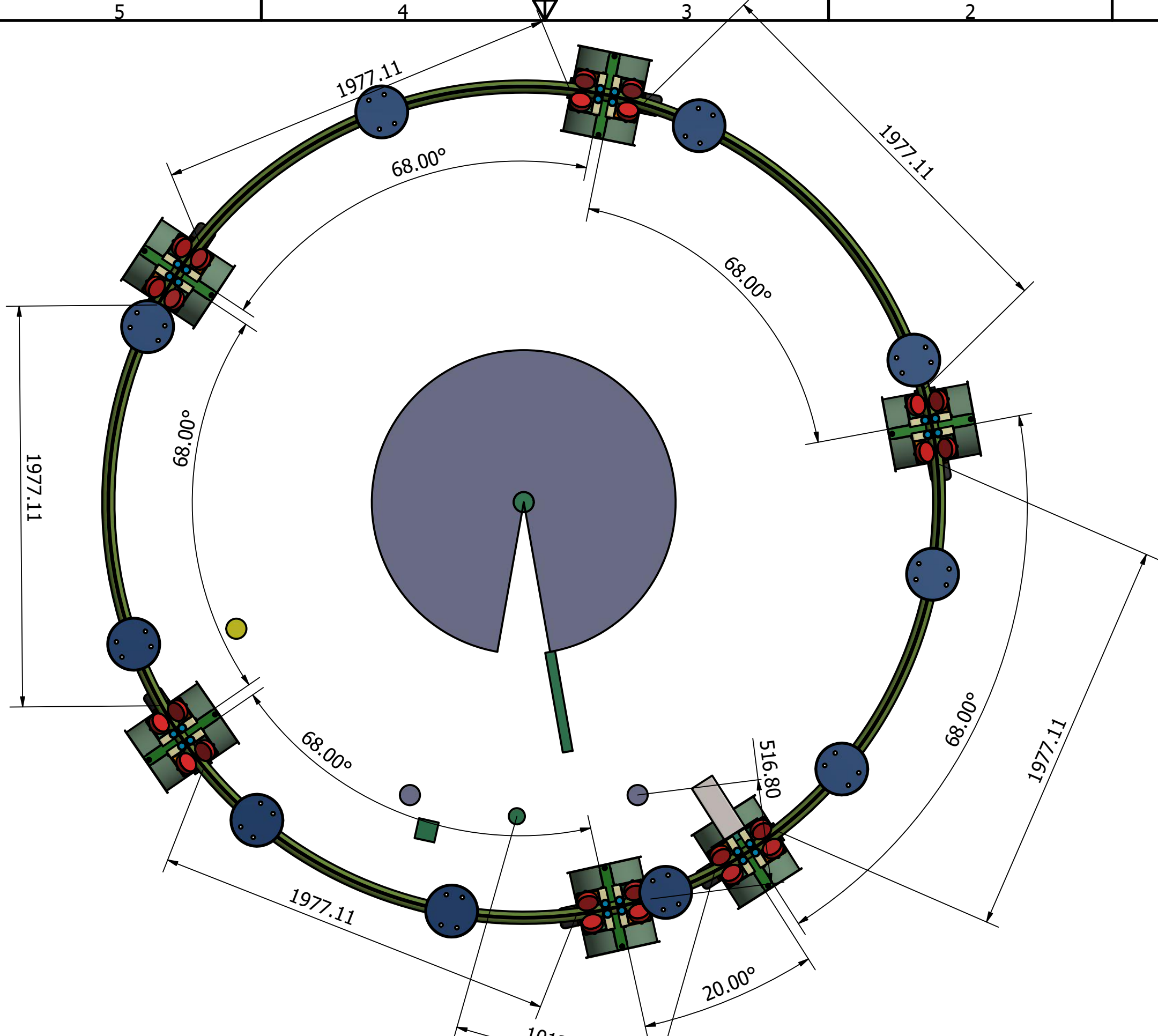

POWERMITE
 A HUDACO GROUP COMPANY

P.O. BOX 7745
 JOHANNESBURG
 2000

TELEPHONE : (011) 271-0000 (32 LINES)
 FAX : (011) 271-0235
 EMAIL : powermite.jhb@global.co.za
 INTERNET : www.powermite.co.za

Customer:		Saldanha FISmidth SR02 & SR04 Round Bar Circular Festoon System	
Mass:	Drawing Date:	Stock No.:	
N/A	06/09/20	Assem-Circular4100mm-RailComp-6CabCar-SR04Circ20	
Scale:	Tolerance:	Drawing No.:	
	±0.2	StkNo... Rev:- 00	

THIS DRAWING IS THE PROPERTY OF POWERMITE AND IS SUBJECT TO THEIR RECALL AND MUST NOT BE REPRODUCED OR ITS CONTENTS DIVULGED WITHOUT WRITTEN PERMISSION

Sheet:
 3 / 5
 A3
 20/09/20

REV.	DATE	DESCRIPTION	BY	CHK.

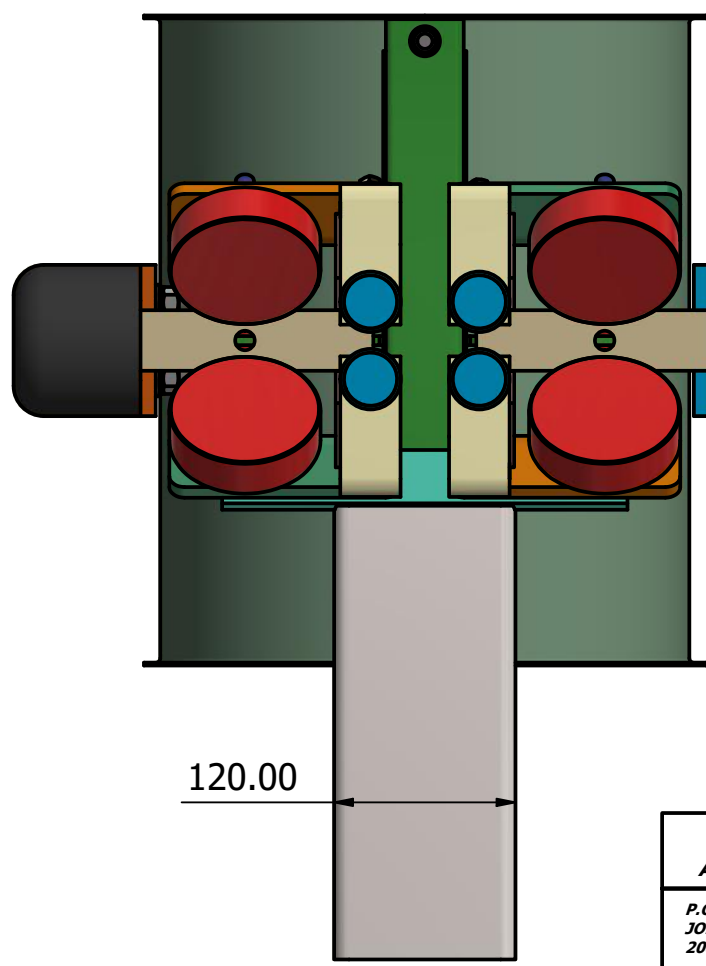
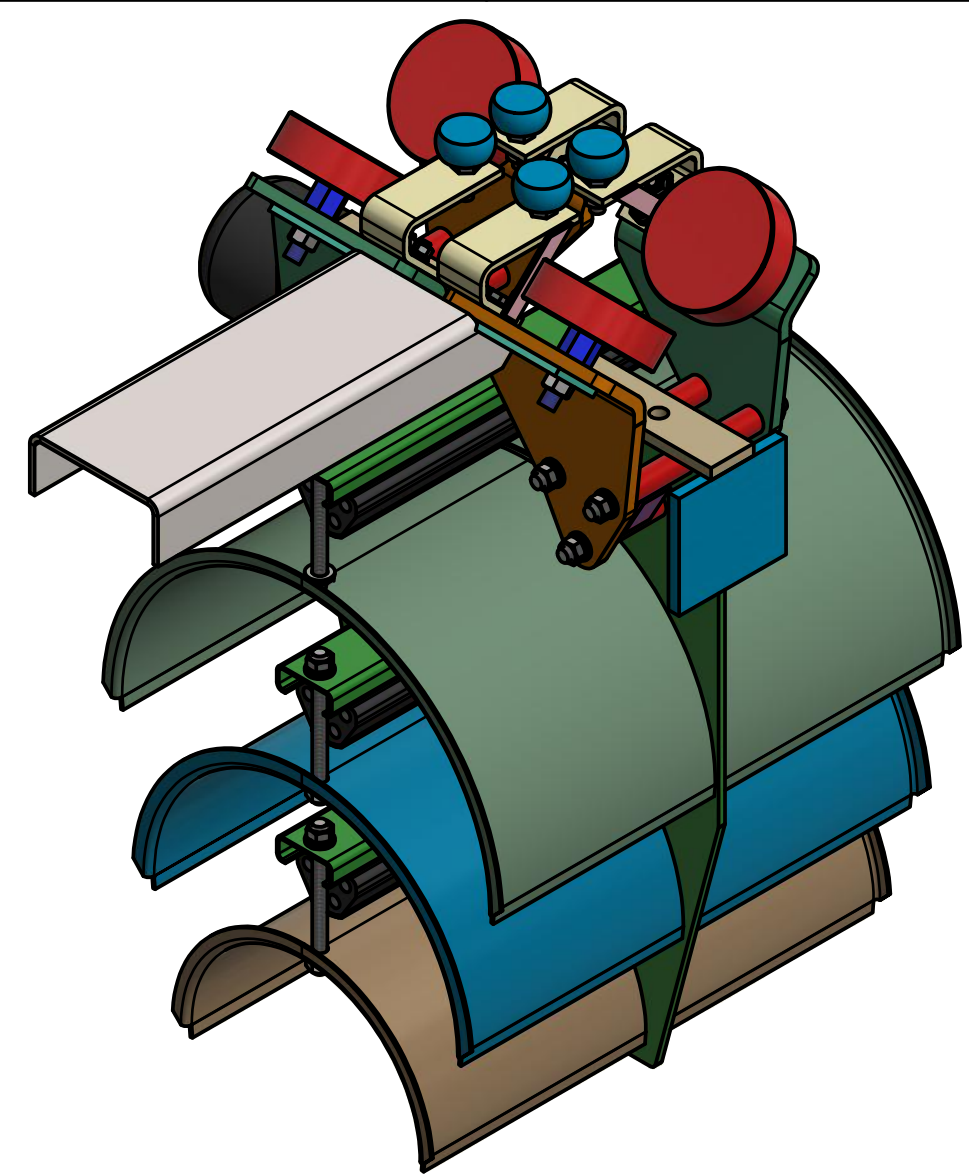
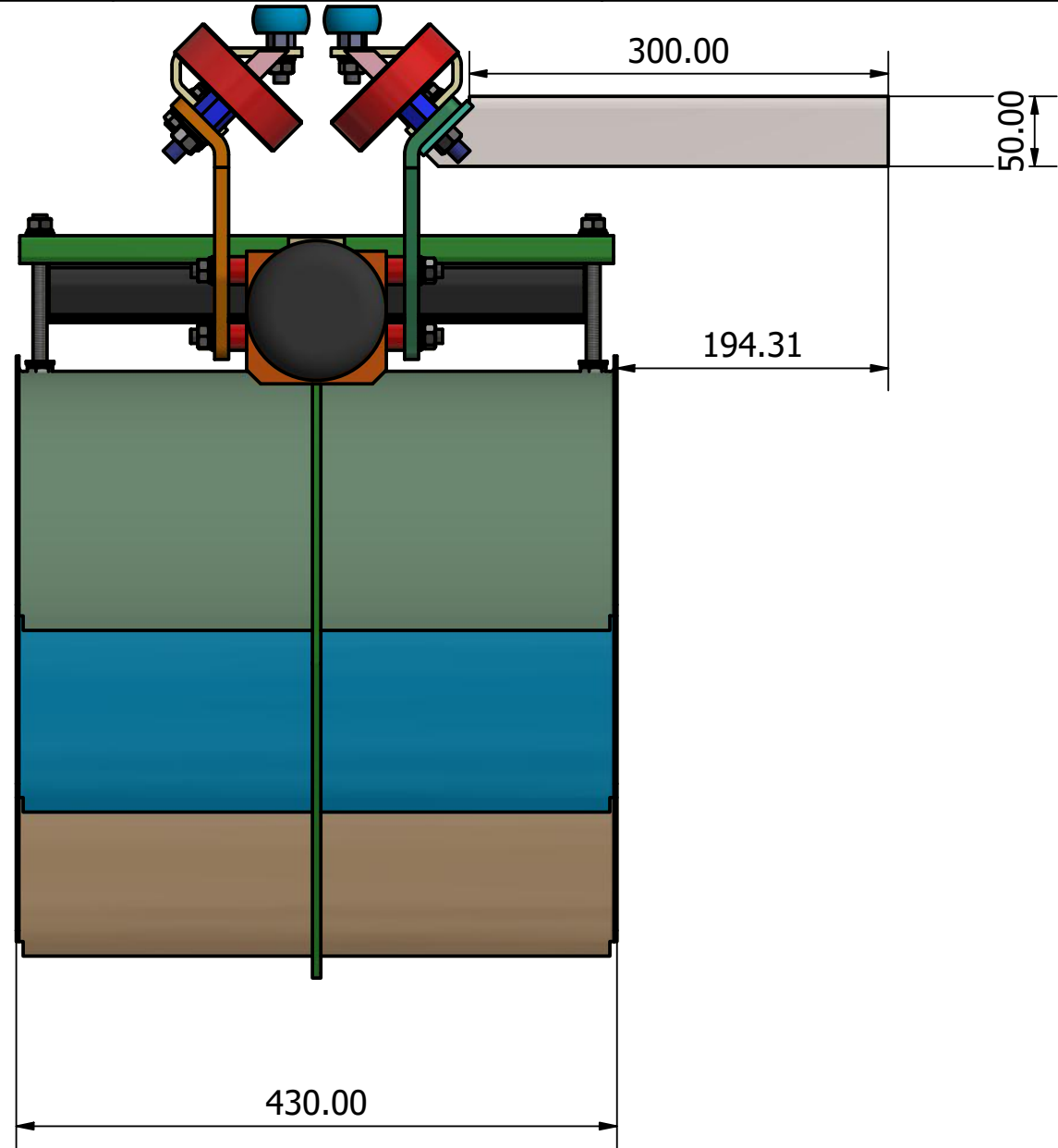
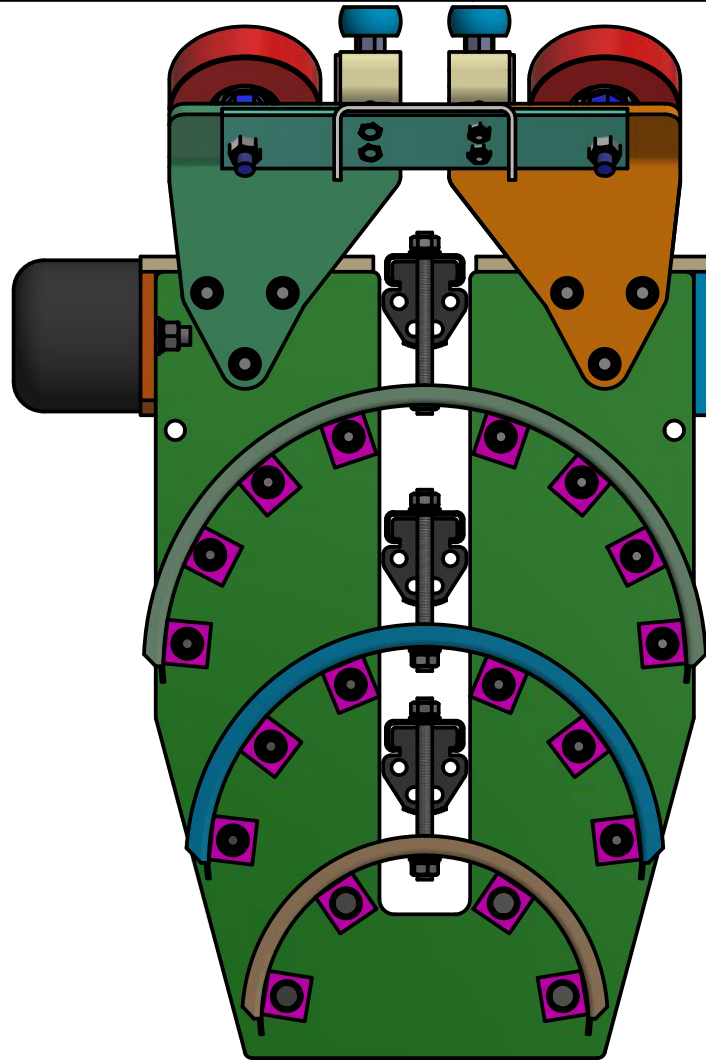

POWERMITE
A HUDACO GROUP COMPANY

P.O. BOX 7745
JOHANNESBURG
2000

TELEPHONE : (011) 271-0000 (32 LINES)
FAX : (011) 271-0235
EMAIL : powermite.jhb@global.co.za
INTERNET : www.powermite.co.za

Customer: Saldanha FISmidth SR02 & SR04 Round Bar Circular Festoon System

Mass: N/A	Drawing Date: 20/09/20	Stock No.: Assem-RndTubeRail-CabCar3DkR175R145R110-SideRoller40mm-Wheel100mm-Towarm-SR04
Scale: ±0.2	Tolerance: ±0.2	Drawing No.: StkNo... Rev:- 00

Sheet:
4 / 5

THIS DRAWING IS THE PROPERTY OF POWERMITE AND IS SUBJECT TO THEIR RECALL AND MUST NOT BE REPRODUCED OR ITS CONTENTS DIVULGED WITHOUT WRITTEN PERMISSION

A3
20/09/20

REV.	DATE	DESCRIPTION	BY	CHK.

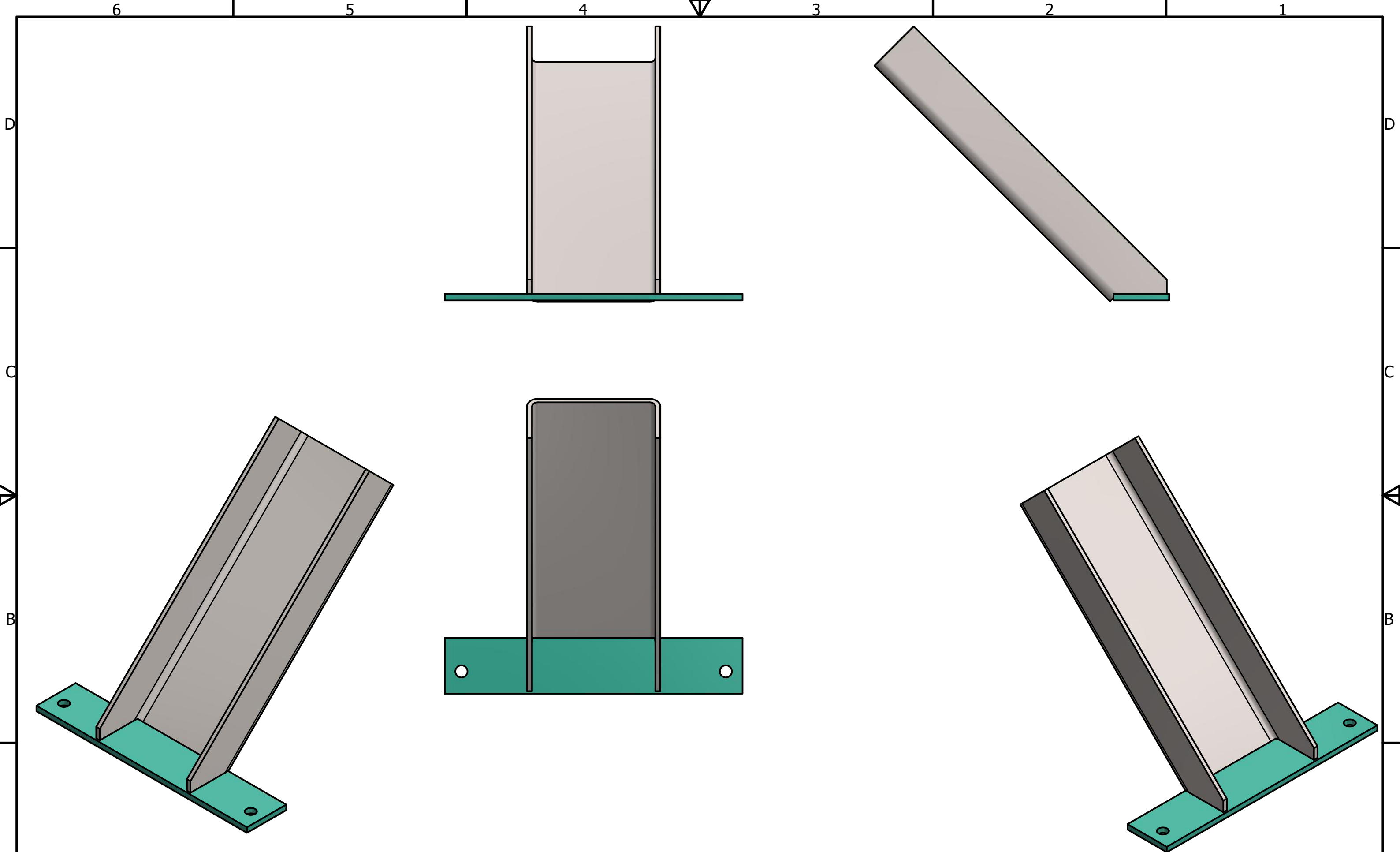

POWERMITE
 A HUDACO GROUP COMPANY

P.O. BOX 7745
 JOHANNESBURG
 2000

TELEPHONE : (011) 271-0000 (32 LINES)
 FAX : (011) 271-0235
 EMAIL : powermite.jhb@global.co.za
 INTERNET : www.powermite.co.za

Customer:		Saldanha FISmidth SR02 & SR04 Round Bar Circular Festoon System		
Mass:	Drawing Date:	Stock No.:		
N/A	20/09/20	Assem-RailCirc-RndTube-4100mm-Towarm-SR04		
Scale:	Tolerance:	Drawing No.:		Sheet:
	±0.2	StkNo... Rev:- 00		5 / 5
THIS DRAWING IS THE PROPERTY OF POWERMITE AND IS SUBJECT TO THEIR RECALL AND MUST NOT BE REPRODUCED OR ITS CONTENTS DIVULGED WITHOUT WRITTEN PERMISSION				A3 20/09/20

REV.	DATE	DESCRIPTION	BY	CHK.

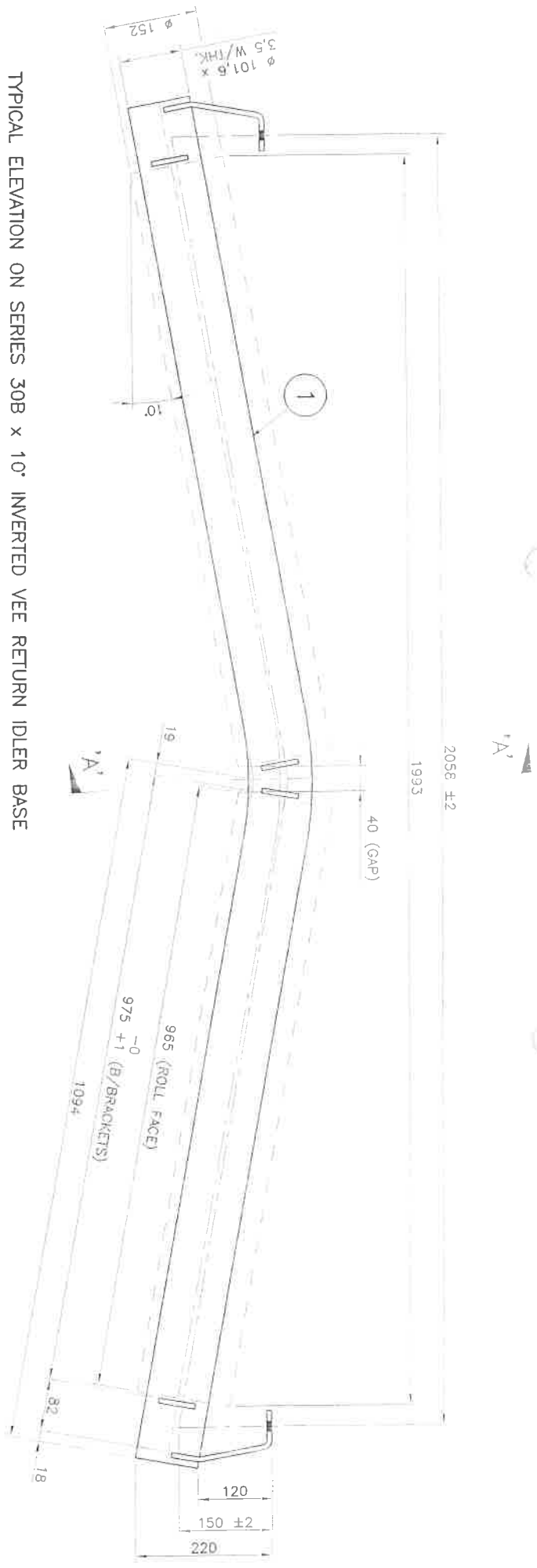

TYPICAL ELEVATION ON SERIES 30B x 10' INVERTED VEE RETURN IDLER BASE

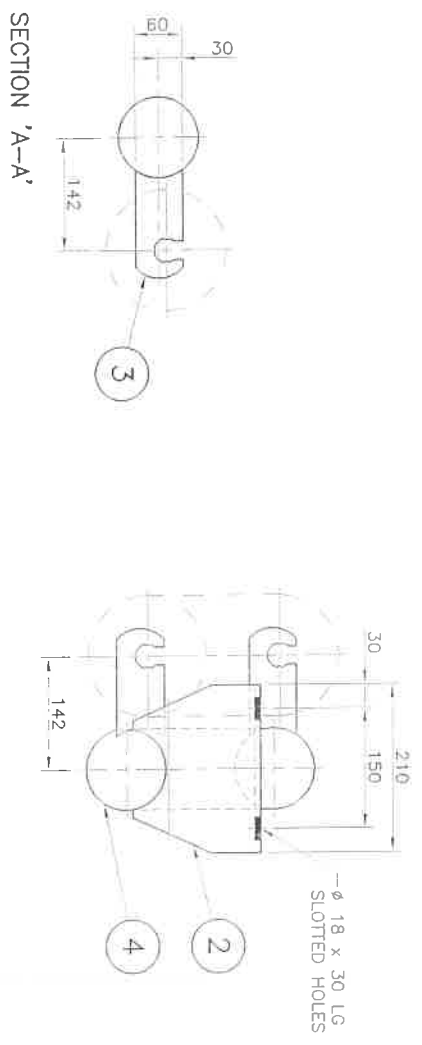



—Ø 18 x 30 LG SLOTTED HOLES

GENERAL NOTES:
 1) ALL WELDING MIN 5 CONT. FILLET UON
 2) FINISH: AS PER ORDER REQUIREMENTS

ITEM	QTY	DESCRIPTION	DRG. NO.	MASS (kg)
4	2	END CAPS	DL20-2486	0,10
3	4	ROLL RETENTION BRACKET	DL20-2487	1,88
2	2	MOUNTING BRACKET	DL20-3610	5,44
1	1	ROLL BASE	DL20-3604	18,60
TOTAL MASS =			26,02	kg

CONTINENTAL MECO

THIS DRAWING IS THE PROPERTY OF CONTINENTAL MECO AND IS A CONFIDENTIAL DOCUMENT. IT MUST NOT BE COPIED OR REPRODUCED WITHOUT PERMISSION IN WRITING.

 P.O. BOX 101904, ALBANY, NY 12210
 South Africa: 908-1-751
 E-mail: mecco@station.co.za

UNLESS OTHERWISE STATED

MACHINING
 UNLESS OTHERWISE SPECIFIED
 SURFACE FINISH: AS PER ORDER REQUIREMENTS

FABRICATION
 ALL DIMENSIONS IN MILLIMETERS UNLESS OTHERWISE SPECIFIED

SCALE	DATE	DRG. No.	TITLE
1:5	16.05.03	VB1-00089	INVERTED V-RETURN BASE

SERIES 30B; 2 ROLL; Ø 152;
 1 800 BELT WIDTH
 10' INVERTED VEE RETURN

2058 ±2 (MOUNTING CENTERS)

1985 ±1

ARRG'T OF 5" VEE RETURN BASE
1800 BELT WIDTH

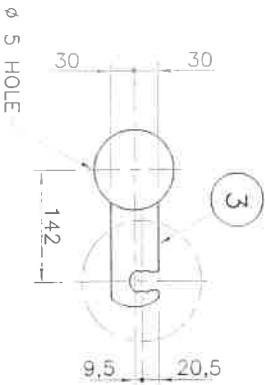
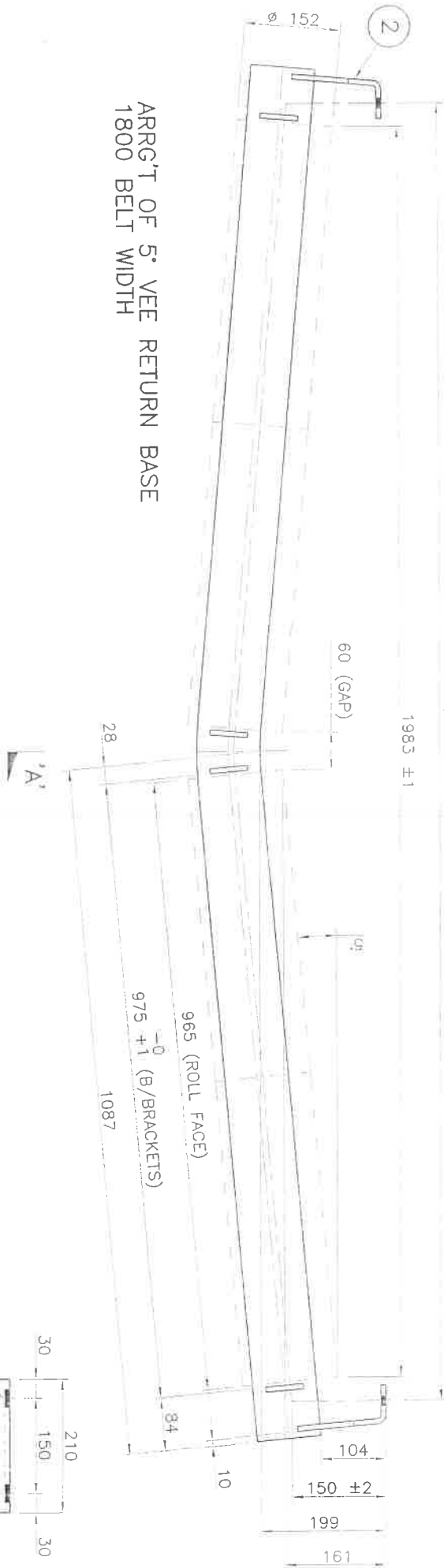

SECTION A - A

GENERAL NOTES:
1) ALL WELDING MIN 5 CONT. FILLET UON
2) FINISH: AS PER ORDER REQUIREMENTS

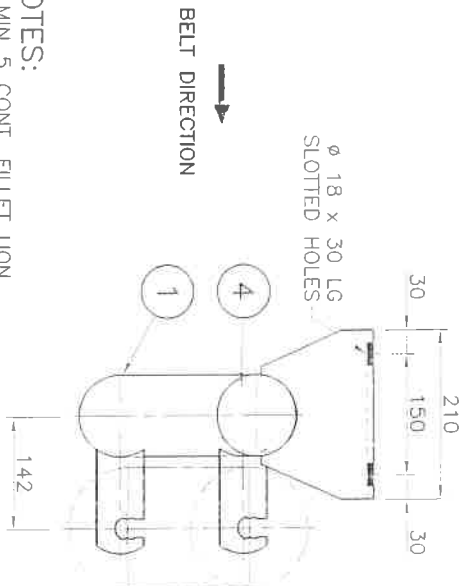

ITEM	QTY	DESCRIPTION	DRG. NO.	MASS (kg)
4	2	END CAPS	DL20-2486	0,10
3	4	ROLL RETENTION BRACKET	DL20-2487	1,88
2	2	MOUNTING BRACKET	DL20-3463	3,50
1	1	ROLL BASE	DL20-3471	18,48
TOTAL MASS :			23,56	kg

UNLESS OTHERWISE STATED

CONTINENTAL MECCO



P.O. Box 12334, Airport, Durban
Tel: (011) 908-1131
Fax: (011) 908-1821
E-mail: mecco@mecco.co.za



THIS DRAWING IS THE PROPERTY OF
CONTINENTAL MECCO
AND IS A CONFIDENTIAL DOCUMENT. IT
MUST NOT BE COPIED OR EXAMINED
WITHOUT PERMISSION IN WRITING.

MACHINING

TO THE DIMENSIONS SPECIFIED
ON THE DRAWING UNLESS
OTHERWISE STATED

FABRICATION

FROM CENTERS UNLESS
OTHERWISE STATED

SCALE: 1 : 5

DATE: 2011

A2

DRG. No. VB1-00081

TITLE
VEE - RETURN BASE
1800 B/W; 30B; 5";
2 ROLL; Ø 152; G/A
METSU MINERALS

DATE:	
BY:	
APP:	
CHK:	
DRG:	