



INVITATION TO BID: NWDOH 12/2024: SUPPLY OF HEALTHCARE WASTE RECEPTACLES AND THE REMOVAL, TREATMENT AND FINAL DISPOSAL OF HEALTH CARE RISK WASTE FROM HEALTH CARE FACILITIES UNDER THE JURISDICTION OF THE NORTH WEST PROVINCE FOR A PERIOD OF FOUR (04) YEARS

Open bids are hereby invited for supply of healthcare waste receptacles and the removal, treatment and final disposal of health care risk waste from health care facilities under the jurisdiction of the North West Province for a period of four (04) years

The conditions contained in the Preferential Procurement Policy Framework Act and 2022 PPPFA Regulations, National Treasury Implementation Guide: Preferential Procurement Regulations 2022, the General Conditions of Contract (GCC) and/ NEC 3 Engineering & Construction Contract, i.e. Annexure "A" and the attached bid forms, as well as any other conditions accompanying this invitation, are applicable.

1. The work procedure the bidder proposes to follow in order to obtain the required result must be clearly outlined and its terms may not conflict with those contained in the General Conditions of Contract.
2. All the documents accompanying this invitation to bid must be completed in detail where applicable, and together with all documentation required in considering the bid, be sealed in an envelope and be deposited in the bid box before the closing date and time.
3. The proposals in a sealed envelope and marked with the Bid Number , Company Name, Closing Date and Closing Time should be deposited in the Bid Box situated at the entrance of the **Department of Health North West, New Office Park Building, Ground floor, Corner First Street and Sekame, Mmabatho [Behind the Crossing Mall]. No correspondence will be entered into regarding non-submission/attachment of required documents after bid closure. Failure to submit all the required documents will render your bid non-responsive**
4. Duly completed and signed original bid documents issued by the Department should be sealed in an envelope marked:

Bid number : NWDOH 12/2024
Company Name :
Closing date : 17 APRIL 2024
Closing time : 11H00

NB: A Compulsory Briefing Session will be on the 26 March 2024 at Office Park Building (Leopard Boardroom) at 11H00

Technical enquiries : Mr Gift Mongologa at 067 416 9049/ 082 548 3410

No telegraphic or facsimile bids will be considered.

5. In terms of the PFMA Treasury Regulations 2005;-

A. **Regulation 16A9. 1 [e] and [f]** the Accounting Officer of the Department may-

- i. Reject a proposal for the award of a contract if the recommended bidder has committed a corrupt or fraudulent act in competing for the particular contract, or
- ii. Cancel a contract awarded to a supplier of goods or services
 - If the supplier committed any corrupt or fraudulent act during the bidding process or the execution of that contract, or
 - If any official or other role-player committed any corrupt or fraudulent act during the bidding process or the execution of that contract that benefitted that supplier.

B. **Regulation 16A9.2 [a] and [b]** the accounting officer or accounting authority-

- i. May disregard the bid of any bidder if that bidder, or any of its directors-
 - Have abused the institution's supply chain management system
 - Have committed fraud or any other improper conduct in relation to such system.

C. Bidders may NOT buy gifts for or ask for cell phone numbers from Bid Committee Members or contract managers during briefing sessions, evaluation and adjudication of bids. In terms of the **NATIONAL**

TREASURY MINUTE 3/3/3/2/10 DATED 23 APRIL 2006-CODE OF CONDUCT FOR BID ADJUDICATION COMMITTEES governing the Conduct of all Bid Committees, Stakeholders and SCM Practitioners involved in the SCM processes:-

- i. Bid information and documentation are confidential
- ii. No unauthorized communication should be made with a bidder/contractor by any member, stakeholder or SCM Practitioner prior to or after any meeting during the evaluation and adjudication of bids

D. IN TERMS OF THE NATIONAL TREASURY SCM PRACTICE NOTE NUMBER: SCM 4 OF 2003; CODE OF CONDUCT FOR SUPPLY CHAIN MANAGEMENT PRACTITIONERS -

"6.5. No person should:-

"6.5.1 Interfere with the supply chain management system of an Institution

"6.5.2 Amend or tamper with any bid after its submission

6. Bidders should ensure that all the relevant documentation required in considering bids are submitted. **Failure to submit all the required documents may render your bid non-responsive**
7. The Department will not be held responsible for missing or duplicated documents. **Bidders are required to sign, number sequentially and initial on each page of the bidding documents. Bid documents must be binded.**
8. It is the ultimate responsibility of every bidder to ensure that his/her bid is duly deposited in the Bid Box situated at the entrance of the Department of Health North West, New Office Park Building, Ground floor, Corner First Street and Sekame, Mmabatho on time before the closing date and time. **The Department of Health shall not be held responsible for any couriered bid documents that do not reach the Bid Box by the Closing date and time. – Couriered documents must be deposited in the bid box by Couriers before the closing date and time. No correspondence will be entered into regarding late bids and couriered documents that were not deposited in the bid box by the bid closing date and time.**

9. The Department of Health reserves the right to award any bid in whole or in part and the Department **does not bind itself to accept the lowest or any bid in whole and price alone is not a determining factor.**
10. National Treasury has per Circular no 3 OF 2015/2016 given instructions to all PFMA Institutions that with effect from 01 April 2016, no quotation or bid may be awarded to any supplier who is not registered as a Prospective Supplier on the National Treasury
11. Central Service Provider Database [CSD]. If you are not registered proceed to complete the registration of your company prior to submitting your bid. Refer to <https://secure.csd.gov.za/> to register your company. Ensure that all documentation on the database are updated and valid. Bidders should further note that the Central Supplier Database (CSD) will be utilized to confirm compliance to tax and other related matters. It is therefore the bidder's responsibility to ensure compliance in all respects.
12. For more information please contact the following:

ADMINISTRATION ENQUIRES:

- Ms T Matshoba 018 391 4043 at [Email: tmatshoba@nwpg.gov.za](mailto:tmatshoba@nwpg.gov.za)

TECHNICAL ENQUIRIES:

- Mr Gift Mongologa at 067 416 9049/ 082 548 3410 at Email: gmongologa@nwpg.gov.za

Potential bidder(s) must reduce all telephonic enquiries to writing and send them to the above email addresses.

13. CONDITIONS TO BID

This bid is issued under the condition that the bidder should at any stage during production or execution or on completion of the bid be subject to inspection. The premises of the bidder or contractor shall be open, at all reasonable hours, for inspection by the representative of the Department of Health or organization acting on behalf of the State. The bidder shall provide, if required, all required facilities for inspections, tests and analysis of the land available, apparatus which may be required for the purpose of such inspection, tests and analysis free of charge unless otherwise specified. The bidder also agrees that the financial standing of the bidder may be examined as part of the inspection

14. RISK ANALYSIS

A risk analysis as per applicable legislation and prescripts shall be used to establish the competency and ability of the successful bidder for the project

15. BID CONDITIONS

- a) Late bids will not be considered. Please note that bids are late if they are received at the address given in the bid document after the bid closing date and time.
- b) Bids will be valid for a period of 90 days.
- c) All bid prices must be quoted in South African currency and must be VAT inclusive.
- d) All the Relevant Forms attached to this bid document must be completed and signed in black ink where applicable by a duly authorized official. Use of tippex and pencil in the bid document are not allowed. Where cancellation has been made, bidders should endorse with a signatures

16. BID ADMINISTRATION DOCUMENTS TO BE SUBMITTED BY ALL BIDDERS:

National Treasury has per **PFMA SCM INSTRUCTION NO.9 OF 2022/2023 MANDOTRY UTILISATION OF THE E-TENDER PORTAL FOR PUBLICATION OF BID OPPORTUNITIES, BID AWARDS AND ANY BID RELATED NOTIFICATIONS DATED 13 OCT 2022** prescribed the mandatory advertisement of bids on the e-tender Publication Portal by all departments. Constitutional institutions and public entities listed In Schedules 2 and 3 to the Public Finance Management Act (PFMA). 1999 (Act No.1 of 1999), hereafter referred to as PFMA compliant institutions. This application is aimed at ensuring that all potential service providers have easy access to advertised bids and are provided with an opportunity to supply PFMA compliant institutions with goods and services, as they may require. With effect from 1 Nov 2022, all PFMA compliant institutions must submit the following information to the relevant treasury's e-Tender Publication Administrator in support its advertisement:

- a) Bid description;
- b) Bid number;
- c) Name of the PFMA compliant institution;
- d) The place where the bid is required;
- e) The closing date and time of the bid;
- f) The PFMA compliant institution's contact details (postal and physical address, Telephone number, etc.);
- g) The place where bids can be collected;

- h) The place where bids should be delivered; and
- i) The bid document, that is,
 - Invitation to Bid-which explains the bid administration requirements and the evaluation criteria, to be complied with by all bidders.
 - SBD Forms Prescribed by National Treasury- to be completed by all Bidders without exception
 - Technical Bid Specifications/Terms of Reference or Bill of Quantities requirements - depending on the technical nature of the bid.

17. BID ADMINISTRATIVE REQUIREMENTS/ CRITERIA TO BE USED IN EVALUATING A BID

The National Treasury **Supply Chain Management Circular Ref 3/4/3/2/10 dated 10 May 2005**: Page 2 Paragraph 1 stipulates that "Bids may only be evaluated in accordance with the evaluation Criteria stipulated in the bid documentation"

All the under-mentioned documentation /criteria required to evaluate this bid must be sealed in an envelope and be deposited in the bid box before the closing date and time.

ALL BIDDERS ARE REQUIRED TO ENSURE THAT THE FOLLOWING DOCUMENTS ARE ATTACHED:-

- (a) Original, fully completed and signed applicable SBD Bid Documents and Preference Claim Forms in terms of the Preferential Procurements Regulations and National Treasury SCM prescripts. **NB. All Bidders are required to fully complete the SBD forms (SBD form 1, 4, 6.1,) as required by the National Treasury PFMA prescripts and the PPPFA Regulations AND to fully complete all other forms as required by the specification, without fail.**
- (b) Copies of Identity Documents of the Directors / Main Shareholders of the company.
- (c) Valid Tax Clearance Certificate/ Tax Compliance Status PIN or CSD Report- The Department will also verify the tax compliance status of bidder
- (d) Only Bidders who collect bid documentation from the Health Department must attach a General Revenue Receipt of **Two Hundred Rand (R200-00)**. Original or Copy of stamped Bank Deposit slip or Electronic Transfer printout or Departmental Revenue Receipt reflecting the name of the Bidder and Bid Number

Bidders are encouraged to download the bid documentation from the E-Tender (for free)

Bank Name : FNB
Account Name : NW Health
Account holder : NWPG
Branch code : 250655
Account number : 62811730747

- (e) Copy of Company Registration Certificate from the Registrar of Companies of all Parties indicating the names of directors or main shareholders of the company. **NB The old Company Registration certificates issued in terms of the repealed 1973 Companies Act which do not show the company Directors 'names are not acceptable. All bidders are required to submit the updated Company Registration Certificates issued by the Registrar of Companies in terms of the 2008 Companies Act, that is, a complete certificates which indicate the names of all Directors or main shareholders of the Company.**
- (f) Bidders are required to submit a copy valid B-BBEE Status level Verification Certificate together with their bids, to substantiate their B-BBEE rating claims.
An EME is required to submit a sworn affidavit confirming their annual total revenue of R10 MILLION or less
- (g) Bidders who do not submit B-BBEE Status level Verification Certificates , a sworn affidavit or are non-compliant contributors to B-BBEE do not qualify for preference points for B-BBEE but shall not be disqualified from the bidding process , but will score points out of price only and zero [0] points out of B-BBEE.
- (h) **In the case of joint venture (JV) or Consortium the following documents must be attached to the Bid documents:-**
- Valid Tax Clearance Certificate pin of all Partners- / Tax Compliance Status PIN or CSD report- The Department will also verify the tax compliance status of bidder
 - Copies of Identity Documents of all Directors / Main Shareholders of the company.
 - Joint venture agreement duly signed by all parties
 - A certificate or agreement regarding shareholder -ship of members

- Copies of Company Registration Certificates from the Registrar of Companies of all Parties to a Joint Venture indicating the names of directors or main shareholders of the companies to the joint venture.-
NB The old Company Registration certificates issued in terms of the repealed 1973 Companies Act which do not show the company Directors 'names are not acceptable. All bidders are required to submit the updated Company Registration Certificates issued by the Registrar of Companies in terms of the 2008 Companies Act, that is, a complete certificates which indicate the names of all Directors or main shareholders of the Company
- A copy of valid Certificate of the Consolidated B-BBEE Status level verification Certificate.-An EME is required to submit a sworn affidavit confirming their annual total revenue of R10 MILLION or less -Bidders who do not submit B-BBEE Status level Verification Certificates , a sworn affidavit or are non-compliant contributors to B-BBEE do not qualify for preference points for B-BBEE but shall not be disqualified from the bidding process , but will score points out of price only and zero [0] points out of B-BBEE
 - (i) A Trust, consortium or a joint venture are required to submit a Consolidated-BBEE Status Level Verification Certificate for every separate bid
 - (j) Public entities and tertiary institutions are required to submit B-BBEE Status level verification certificates together with their bids

All the bid documents should be completed, signed and sealed in an envelope and deposited in the Bid Box, situated at the entrance of the **Department of Health North West, New Office Park Building, Ground Floor, Corner First Street and Sekame, Mmabatho.**

18. VALIDITY OF B-BBEE STATUS LEVEL VERIFICATION CERTIFICATES

- AO/AAs must ensure that the B-BBEE Status Level Verification Certificates submitted are issued by the following agencies:
 - Tenderers other than EMEs
 - I. Verification agencies accredited by SANAS; or
 - Tenderers who qualify as EMEs
 - II. Sworn affidavit signed by the EME representative and attested by a Commissioner of oaths.

18.1 Verification agencies accredited by SANAS

- 18.1.1 These certificates are identifiable by a SANAS logo and a unique BVA number.
- 18.1.2 Confirmation of the validity of a B-BBEE Status Level Verification Certification can be done by tracing the name of the issuing Verification Agency to the list of all SANAS accredited agencies. The list is accessible on http://www.sanas.co.za/directory/bbee_default.php
- 18.1.3. The relevant BVA may be contacted to confirm whether such a certificate is valid.
- 18.1.4 As a minimum requirement, all valid B-BBEE Status Level Verification Certificates should have the following information detailed on the face of the certificate:

- The name and physical location of the measured entity
- The registration number and, where applicable, the VAT number of the measured entity;
- The date of issue and date expiry;
- The certification number for identification and reference;
- The scorecard that was used (for example QSE, Specialized or Generic);
- The name and / or logo of the Verification Agency;
- The SANAS logo
- The certificate must be signed by the authorized person from the Verification Agency; and
- The B-BBEE Status Level of Contribution obtained by the measured entity

19. VERIFICATION OF B-BBEE LEVELS IN RESPECT OF EMEs

- 19.1. In terms of the Generic Codes Practice, an enterprise including a sole propriety with annual total revenue of R10 million or less qualifies as an EME
- 19.2 In instances where Sector Charters are developed to address the transformation challenges of specific sectors or industries, the threshold for qualification as an EME may be different from the generic threshold of R10 million. In such instances, the relevant sector Charter threshold will therefore be used as a basis for a potential bidder to qualify as an EME. (For example the approved threshold for EMEs for the Tourism and Construction Sector Charters are R2.5 million and R1.5 million respectively)

19.4 An EME that is regarded as a Specialized Enterprise is required to submit a sworn affidavit confirming their annual turnover/allocated budget/ gross receipt of R10 million or

19.5 An EME may be measured in terms of the QSE scorecard should they wish to maximize their points and move to a higher B-BBEE recognition level. It is in this context that an EME may submit a B-BBEE verification certificate

20. EVALUATION CRITERIA FOR THIS BID IS AS FOLLOWS:

1. EVALUATION CRITERIA

2. 90/10 PREFERENTIAL POINT SYSTEM

90 = Price (NOTE: All bid price/should be VAT inclusive)

10 = Preferential points (Points will be allocated according to BBEE Rating)

Specific Goals	Procurement Transactions Preference Points allocated out of 10
B-BBEE Status level of Contributor	5
1	3
2	2
3, 4, 5, 6, 7, 8 and Non-compliant contributor	0
Enterprises located in a specific District Municipality, Township or region for work to be done or services to be rendered in that area (Mandatory)	2
Residing within the North West Province where the service is required.	2
Residing outside the North West Province	0
Designated Groups (any bid that meets 1 or more of the 3 will get the maximum points)	3
<input type="checkbox"/> Enterprises 51% owned by black women. <input type="checkbox"/> Enterprises 51% owned by people with disability. <input type="checkbox"/> Registered Cooperatives within the North West	3

NB: Points will be allocated to all those who submitted their BBEE verification certificates/Sworn Affidavit and Confirmation of preferred address on CSD will be checked and printed by the SCM Practitioner for locality points.

CHIEF DIRECTOR: SUPPLY CHAIN MANAGENT

DATE: 2024/03/11

COMPLIANCE CHECKLIST

NB. THE BIDDERS MUST COMPLETE THE CHECKLIST TO VERIFY/CONFIRM WHETHER A BIDDER HAS ATTACHED ALL OF THE BID ADMINISTRATIVE REQUIREMENTS

NO	REQUIREMENT	HAVE YOU ATTACHED
		<i>Answer Yes or No</i>
1	Compulsory Briefing session	
2	General Revenue Receipt should be attached by all bidders who obtained hardcopy bid documentation at the Offices of the Health Department- Original Bank Deposit slip or Electronic Transfer printout receipt reflecting the name of the Bidder and Bid Number. NB–Bidders who download the bid documentation from the E-Tender Website are exempted from this requirement. Bidders are encouraged to download the bid documentation from the E-Tender Website for free.	
3	Original, fully Completed and signed applicable Bid Documents and Preference Claim Forms in terms of the Preferential Procurement Regulations. NB. All Bidders are required to fully complete the SBD forms as required by the National Treasury PFMA prescripts and the 2022 PPPFA Regulations <u>AND</u> fully complete all other forms as required by the specification, without fail. Any bidder having not complied with these requirements shall be disqualified. [Each of the following SBD form must be fully completed and signed.]	
3.1	Availability of signed and fully completed SBD 1- Invitation to bid	
3.2	Availability of signed and fully completed SBD 4- Declaration of Interest	
3.3	Availability of signed and fully completed SBD 6.1 - Preference Points Claim Form in Terms of the Preferential Procurement Regulations 2022	
4	Copies of Identity Documents of all Directors / Main Shareholders of the company.	
5	Valid Tax Clearance Certificate / Tax Compliance Status PIN or CSD Report- Indicate the expiry date[s] of all the TCC The Department will also verify the tax compliance status of bidder	
6	Copy of Company Registration Certificate from the Registrar of Companies of all Parties indicating the names of directors or main shareholders of the company. NB The old Company Registration	

	<p>certificates issued in terms of the repealed 1973 Companies Act which do not show the company Directors 'names are not acceptable. All bidders are required to submit the updated Company Registration Certificates issued by the Registrar of Companies in terms of the 2008 Companies Act, that is, a complete certificates which indicate the names of all Directors or main shareholders of the Company without fail</p>	
7	<p>TOTAL BID PRICE INCLUDING VAT</p> <p>AMOUNT.....</p>	
8	<p>Bidders are required to submit a copy of valid B-BBEE Status level Verification Certificate, together with their bids, to substantiate their B-BBEE rating claims.</p> <p>An EME is required to submit a sworn affidavit confirming their annual total revenue of R10 MILLION or less</p> <p>Bidders who do not submit B-BBEE Status level Verification Certificates , a sworn affidavit or are non-compliant contributors to B-BBEE do not qualify for preference points for B-BBEE but shall not be disqualified from the bidding process , but will score points out of price only and zero [0] points out of B-BBEE</p>	
<p>9 IN THE CASE OF JOINT VENTURE (JV) OR CONSORTIUM THE FOLLOWING DOCUMENTS MUST BE ATTACHED TO THE BID DOCUMENTS</p>		
9.1	<p>Copy of Valid Tax Clearance Certificate of all Partners- / Tax Compliance Status PIN or CSD report-</p> <p>The Department will also verify the tax compliance status of bidder Indicate the expiry date[s] of all the TCC of the JV partners.</p>	
9.2	<p>Copies of Identity Documents of all Directors / Main Shareholders of all Parties to the Joint Venture.</p>	
9.3	<p>Joint venture agreement duly signed by all parties</p>	
9.4	<p>General Revenue Receipt should be attached by all bidders who obtained hardcopy bid documentation at the Offices of the Health Department. Original Bank Deposit slip or Electronic Transfer printout receipt reflecting the name of the Bidder and Bid Number NB-Bidders who download the bid documentation from the E-Tender Website are exempted from this requirement</p>	
9.5	<p>Copies of Company Registration Certificates from the Registrar of Companies of all Parties to a Joint Venture indicating the names of directors or main shareholders of the companies to the joint venture. - NB</p>	

	The old Company Registration certificates issued in terms of the repealed 1973 Companies Act which do not show the company Directors 'names are not acceptable. All bidders are required to submit the updated Company Registration Certificates issued by the Registrar of Companies in terms of the 2008 Companies Act, that is, certificates which indicate the names of all Directors or main shareholders of the Company, without fail.	
9.6	<p>A copy of a valid Certificate of the Consolidated B-BBEE Status level verification Certificate or confirmation letter.</p> <p>An EME is required to submit a sworn affidavit confirming their annual total revenue of R10 MILLION or less</p> <p>Bidders who do not submit B-BBEE Status level Verification Certificates , a sworn affidavit or are non-compliant contributors to B-BBEE do not qualify for preference points for B-BBEE but shall not be disqualified from the bidding process , but will score points out of price only and zero [0] points out of B-BBEE</p>	
10	A Trust, consortium or a joint venture are required to submit a consolidated B-BBEE Status Level Verification Certificate for every separate bid	
11	Public entities and tertiary institutions are required to submit B-BBEE Status level verification certificates together with their bids	
12	<p>Duly completed and signed original bid documents issued by the Department should be sealed in an envelope marked:</p> <p>Bid number : NWDOH 12/2024</p> <p>Company Name :</p> <p>Closing date : 17 APRIL 2024</p> <p>Closing time : 11H00</p>	
13	Address and contact details:	

SIGNATURE BY BIDDER:

DATE:



Ground Floor,
Health Office Park
Private Bag X 2068
MMABATHO

**DEPARTMENTAL BID ADJUDICATION
COMMITTEE**

Tel no: 018 391 4514
Enq: Ms N. Moeketsi
Email:nmoeketsi@nwpg.gov.za

1. NAME OF BID

SUPPLY OF HEALTHCARE WASTE RECEPTACLES AND THE REMOVAL, TREATMENT AND FINAL DISPOSAL OF HEALTH CARE RISK WASTE FROM HEALTH CARE FACILITIES UNDER THE JURISDICTION OF THE NORTH WEST PROVINCE FOR A PERIOD OF FOUR (04) YEARS

2. PURPOSE

To invite open bids for Supply of healthcare waste receptacles and the removal, treatment and final disposal of health care risk waste from health care facilities under the jurisdiction of the North West Province.

3. BACKGROUND

Health Care Risk Waste (HCRW) is considered to be the hazardous component of Health Care Waste (HCW) generated in both large and small health care facilities. HCRW has the potential to create a number of environmental, health and safety risks, depending on the particular HCRW category, the way in which it is handled, stored and transported as well as the way in which exposure takes place

4. EXPECTED DELIVERABLES AND OUTCOMES

Supply of healthcare waste receptacles and the removal, treatment and final disposal of health care risk waste and other related items from participating health care facilities under the jurisdiction of the North West.

5. TIME FRAME/DURATION OF BID

Four (4) years

6. BIDDER REQUIREMENTS

- 6.1 Valid waste management permit for transportation and storage issued by Department of Environmental Affairs
- 6.2 Letter of good standing with department of labour.

6.3 AEL (atmospheric emission License) issued by the municipality where treatment side is located.

Where the AEL (atmospheric emission License) is issued in the name of the third party, the bidder must submit a letter of commitment of the third party, permitting the bidder to use treatment plant.

6.4 Relevant company experience in similar projects not older than 5 years. Minimum of two (02) reference letters from the below categories with contact details must be attached:

- a) Hospitals
- b) Health Centers
- c) Clinic/Forensic/mortuaries

6.5 Transportation- proof of the below must be attached

a) Own Transport (attach vehicle registration certificates as per 8.2 of technical specification)

OR

b) Hired/ Leased transport (attach letter of intension to lease as per 8.2 of technical specification)

7. Briefing session

A compulsory briefing session will be on the **26 March 2024 at 11h00**

8. SPECIAL CONDITIONS

- The department reserves the right to award in whole or in part.
- Bidders must state which district they are bidding for.
- The bidder to provide a contingency plan in case of a breakdown of the treatment plant

9. TECHNICAL SPECIFICATIONS

Kindly find Annexures of the Technical specification attached

10. EVALUATION CRITERIA

90/10 PREFERENTIAL POINTS

90 = Price

NOTE: All bid price/should be VAT inclusive.

10 = Preferential Points

(Points will be allocated according to specific goals table below)

Specific Goals	Procurement Transaction Preference Points allocated out of 10
B-BBEE Status level of Contributor	5
1	5
2	4
3, 4, 5, 6, 7, 8 and Non-compliant contributor	0
Enterprise located in a specific Local Municipality or District Municipality, Township or region for work to be done or services to be rendered in that area (Mandatory)	2
Residing within the North West Province.	2
Residing outside the North West Province	0
Designated Groups (any bid that meets 1 or more of the 5 will get the maximum points)	3
<ul style="list-style-type: none"> ▪ Enterprises 51% owned by black women. ▪ Enterprises 51% owned by people with disability. ▪ Enterprises 51% owned by black youth. ▪ Enterprises 51% owned by black military veterans ▪ Registered Cooperatives within the North West department of Health database 	3

NB: Points will be allocated to all those who submitted their BBEE verification certificates/Sworn Affidavit and Confirmation of preferred address on CSD will be checked and printed by the SCM Practitioner for locality points.

Technical Enquiries to be directed to:

Gift Mongologa : 018 391 4065: e- mail: GMongologa@nwpg.gov.za



TECHNICAL SPECIFICATIONS FOR THE COLLECTION, REMOVAL, TREATMENT AND FINAL DISPOSAL OF HEALTH CARE RISK WASTE FROM PARTICIPATING HEALTH CARE FACILITIES

Table of Contents

- 1. Introduction and Interpretation.....3
- 2. General.....3
- 3. Definitions.....3
- 4. Scope of supply..... 11
 - 4.1. The Services..... 11
 - 4.2. The Facilities..... 12
- 5. The Waste 12
- 6. Supply of Disposable Containers 14
 - 6.1. Distribution of Disposable Containers 15
 - 6.2. Brackets, Baskets and Freestanding Racks..... 15
 - 6.3. Disposable Containers Delivery Point..... 16
- 7. Collection of Health Care Risk Waste.....16
 - 7.1. Waste Collection Point..... 16
 - 7.2. Storage of HCRW 17
 - 7.3. Frequency of HCRW Collection 18
 - 7.4. Weighing of the HCRW..... 18
 - 7.4.1 Hospitals..... 18
 - 7.4.2. Clinics and Community Health Centres 18
 - 7.4.3. Calibration of Scales..... 18
 - 7.4.4. Weighing Discrepancies..... 19
 - 7.5. Recording of HCRW Collected..... 19
 - 7.6. Pathological Waste at Clinics..... 19
 - 7.7. Collection of Extraordinary Items 20
 - 7.8. Mobile Clinics..... 20
- 8. Transport.....20
 - 8.1. Requirements for Transportation 20
 - 8.2. Requirements for the HCRW Vehicles..... 21
- 9. Treatment of HCRW21
 - 9.1. Requirements for Treatment of HCRW..... 22
 - 9.2. Handling and Storing of HCRW at the Treatment Plant..... 22
 - 9.3. HCRW Storage during a Planned Outage 22
- 10. Residues Disposal22
- 11. Training Programme23
- 12. Mobilization and Rollout.....23
 - 12.1 Mobilization..... 23
 - 12.1.1 Rollout Plans..... 23
 - 12.2 Rollout Period 24
 - 12.4 Consultancy during the Rollout Period 25
- 13. Handover of Services.....25
- 14. Communications26
 - 14.1 Meetings..... 26

14.2 Reporting	26
14.2.1 Annual Report	26
14.2.2 Monthly Report	28
14.2.3 Incident Report	29
14.3 Inspections	29
15. Backup Arrangements	29
16. Health and Safety	30
17. Payment for Services and Supplies	31
17.1 Supply and Distribution of Disposable Containers.....	31
17.2 Collection, Transport, Treatment and Disposal of the Health Care Risk Waste.....	31
17.3 Supply, Distribution and Installation of Durable Items	32
17.4 Extraordinary Items	32
17.5 Penalties.....	32
17.6 Adjustment of Prices and Penalties	33
ANNEXURE 1: SPECIFICATION FOR DISPOSABLE AND NON-DISPOSABLE CONTAINERS.....	34
A1.1: Sharps Containers	34
A1.2: Specican Containers	36
A1.3: Liners	41
ANNEXURE 2: LIST OF HEALTH CARE FACILITIES	46
ANNEXURE 3: SPECIFICATIONS FOR HEALTH CARE RISK WASTE COLLECTION TRAILER.....	52
ANNEXURE 4: NORTH WEST HEALTHCARE RISK WASTE COLLECTION POINTS.....	54
ANNEXURE 5: PRICE LISTS - COST OF 1KG OF HEALTHCARE RISK WASTE	58
A5.1 Preamble.....	58
A5.2 Cost of 1kg of Healthcare Risk Waste:.....	59
ANNEXURE 6: PRICE LISTS FOR SUPPLY OF DISPOSABLE CONTAINERS (RECURRING ITEMS).....	60
ANNEXURE 7: PRICE LISTS FOR SUPPLY OF DURABLE ITEMS (ONCE-OFF ITEMS)	72

1. Introduction and Interpretation

Save as otherwise specified in these specifications, all words, expressions and abbreviations used in these specifications shall (unless the context otherwise requires or admits) have the meanings respectively assigned to them in Section 3 of these specifications. For the purposes of compiling the provisions of these specifications, no specific requirement specified herein shall limit the generality of any other requirement.

All bids shall comply with these specifications. Alternative bids shall only be considered by the Department if the Bidder also submitted a conforming bid.

These specifications shall apply to the Contract for all health care facilities falling under the North West Department of Health, with the List of Health Care Facilities and the Schedule of Rates specified for the whole province.

The several documents forming the Contract are to be taken as mutually explanatory of one another and in the event of there being any ambiguity in or discrepancy between the various documents, the documents will take precedence in the following order:

- Specifications and Annexures;
- Special Conditions of Contract;
- Conditions of Bid;
- General Conditions of Contract, Bid and Order.

2. General

These specifications specify and contain the Department's requirements for the Services and the Contractor shall, at all times throughout the Contract Period, perform and complete each of the Services in such manner and at such times as shall comply with and satisfy the requirements of these Specifications and their Annexures.

3. Definitions

In addition to the Definitions presented in the General Conditions of Bid, Contract and Order, and unless in this Contract the context otherwise requires or admits, the following words and/or expressions shall have the meanings respectively ascribed to them below.

Where the context requires, words importing the singular number shall include the plural and vice versa.

Basket	:	Means a device for holding a disposable plastic liner container. Figures 3 and 4 in Annexure 1 of the specifications [Specifications for Disposable Containers] show typical examples of Baskets.
Bracket	:	Means a device for holding a disposable rigid container such as a Sharps Container or a Specican Container. Figures 1 and 2 in Annexure 1 of the specifications [Specifications for Disposable Containers] show typical examples of Brackets.
Chemical Waste	:	Means solid, liquid and gaseous products that are to be discarded and that contain dangerous or polluting chemicals that pose a threat to humans, animals or the environment, when improperly disposed of.
Clinic	:	Means a Facility designated by "Clinic" in the List of Health Care Facilities or a Facility designated as "CHC" in the List of Health Care Facilities.

Collection Programme	:	Means the Contractor's programme for collecting Health Care Risk Waste from the Facilities. The programme shall specify days of the week and approximate times that Health Care Risk Waste will be collected from each Facility.
Commencement of Services Date	:	Means the date on which the Contractor shall take responsibility for removing Health Care Risk Waste from all Facilities in the District, i.e., the date on which the Rollout Period starts.
Community Health Centre	:	Means a Facility designated as such by "CHC" in the List of Health Care Facilities.
Competent Authority	:	Means any agency, department, board, committee, governmental body, local authority, court, inspectorate, official regulator, public statutory person or appointee of the Republic or the Province (whether autonomous or not) having jurisdiction (whether by virtue of Legislation, delegated authority, customary law or otherwise) over any of the parties hereto, the subject matter of this Contract and/or the performance of any of the parties' respective obligations under this Contract.
Container		Means disposable or reusable vessel in which waste is placed for handling, transportation, storage, or eventual treatment or disposal (or both)
Contract Period	:	Means the period from the Commencement of Services Date to the date that the Contract expires. The Contract Period would be 4 years.
Controlled Combustion Treatment	:	Means any method, technique or process to render health care risk waste to flue gases and residues, by means of oxidation at high temperatures. This includes oxidation of waste as well as other thermal treatment processes such as pyrolysis gasification or plasma processes insofar as the substances resulting from the treatment are subsequently incinerated.
Cytotoxic Waste		Means waste that is toxic to cells and that can lead to cell death.
Disposable Container	:	Disposable Containers shall include the following: a) Sharps Containers, including containers for long sharps; b) Specican Containers for Pathological Waste; c) Pharmacan Containers for Chemical Waste; d) Red liners for General Infectious Waste, including sealing mechanisms for liners.
Department's Representative	:	Means such persons as the Department may appoint as the Department's Representative for the purposes of managing the HCRW Contract at Provincial, District and Facility level.
District	:	Means the North West Department of Health Districts [Dr R.S. Mompoti, Dr Kenneth Kaunda, Ngaka Modiri Molema or Bojanala] as specified in the Contract.
District Office	:	Means the Department's administrative office in the District.
District Rollout Plan	:	Means a detailed strategy for the rollout at all Facilities within a particular District.
Domestic Waste		Means waste, excluding hazardous waste, that emanates from premises that are used wholly or mainly for residential, educational, health care, sport or recreation purposes
Durable Items	:	Means collectively Brackets, Baskets and Freestanding Racks.
Environment	:	Environment is defined as i) the natural environment, consisting of air, water, land and all forms of life, ii) the social, political, cultural, economic and working context and other factors that determine people's place in and influence on the environment, and iii) natural and constructed spatial surroundings.
Exposure	:	The intake of radiation or pollutant by organisms present in a particular environment (i.e. human, natural), which represents a potential health threat to the living organisms in that environment.
Extraordinary Items	:	Disposable items not forming part of the normal daily Waste stream, but with characteristics similar to that of Waste, e.g., soiled mattresses.
Facility	:	Means a regional hospital, district hospital, community health centre, clinic, mortuary or any other health care facility included in the List of Health Care Facilities.

Facility Rollout Plan	: Means a detailed strategy for the Rollout at individual Facilities within a particular District.
Freestanding Rack	: Means a loose device standing on a floor for the purpose of holding a disposable plastic liner. Figure 5 in Annexure 1 of the Specifications [Specifications for Disposable Containers] shows a typical example of a Freestanding Rack.
General Infectious Waste	: Means Infectious Waste, other than Sharps Waste and Pathological Waste, which is suspected to contain pathogens and normally causes, or significantly contributes to the cause of increased morbidity or mortality of human beings. It inter alia includes items such as blood, contaminated dressings, contaminated diapers or any other disposable items suspected of being infectious.
Genotoxic Waste	Includes but is not limited to certain cytostatic drugs, vomit, urine, or faeces from patients treated with cytostatic drugs, genotoxic substances or chemicals which may have mutagenic, teratogenic or carcinogenic properties.
Good Engineering and Operating Practices	: Means (in relation to the performance of any activity, duty, responsibility and/or obligation of the Contractor to which this standard is stated in this Contract to apply) the standards, practices, methods and procedures and the degree of skill, care, diligence, prudence and foresight that would reasonably be expected of a skilled and experienced contractor engaged in the same type of undertaking under the same or similar factual, practical and/or physical circumstances at the time when the relevant decision or judgement is made and/or the relevant act or operation is performed and, without prejudice to the foregoing generality, shall include taking all reasonable steps to ensure that: <ul style="list-style-type: none"> • adequate materials, resources and supplies, are constantly available to undertake the Services under normal conditions and reasonably anticipated abnormal conditions; • sufficient personnel are available and are adequately experienced and trained to transport and handle the Waste and operate the Treatment Plant properly, efficiently, and within the manufacturers' guidelines and specifications and are capable of adequately responding to emergency conditions; • preventive routine and non-routine maintenance and repairs are performed to the Treatment Plant and the Contractor's equipment in general, on a basis that ensures reliable and safe operation, and are performed by knowledgeable, trained and experienced personnel utilising suitable equipment, tools and procedures; • appropriate monitoring and testing is done to ensure that all equipment at the Treatment Plant and the Contractors equipment in general, is functioning as designed and to provide assurance that such equipment will function properly under normal conditions; • appropriate planned procedures are carried out to ensure the proper collection, transport, handling, treatment and disposal of the Waste, Residues and effluents under normal conditions and reasonably anticipated abnormal conditions; • the Department's Requirements, all Necessary Consents and all applicable Statutory Requirements are complied with.
Handover Period	: Has the meaning given to it in section 13 of these specifications
Health Care General Waste	: Means waste that does not pose an immediate hazard or threat to health or to the environment, and includes: <ol style="list-style-type: none"> a) domestic waste; b) building and demolition waste; c) business waste; and d) insert waste.

Health Care Risk Waste	: Means waste capable of producing any disease and includes but is not limited to the following: a) Chemical waste; b) Cytotoxic waste. c) Genotoxic waste; d) Infectious waste; e) Isolation waste; f) Laboratory waste; g) Pathological waste; h) Pharmaceutical waste; i) Pressurized container waste; j) Radioactive waste; k) Sharps waste; and l) Waste with heavy metals.
Health Care Waste	: Means waste generated at a health establishment and includes both health care general waste and health care risk waste.
Health Care Waste (HCW) Officer	Means the person that shall be appointed or designated by the person in charge of the Department of Health or a health facility as a Health Care Waste Officer and/or Departmental Representative.
Hospital	: Means a Health Care Facility larger than a Community Health Centre.
Inert Waste	: Means waste that: a) does not undergo any significant physical or chemical or biological transformation after disposal; b) does not burn, react physically or chemically biodegrade or otherwise adversely affect any other matter or environment with which it may come into contact; and c) does not impact negatively on the environment, because of its pollutant content and because the toxicity of its leachate is insignificant.
Infectious Waste	: Means material suspected to contain pathogens (bacteria, viruses, parasites or fungi) in sufficient concentrations or quantity to cause disease in susceptible hosts.
Isolation Waste	: Means waste containing discarded materials contaminated with excretion, exudates, or secretions from humans or animals who or which are required to be isolated in order to protect others from highly communicable or zoonotic diseases.
In-Service Training	: Means the training provided by the division in the Department responsible for organising training programmes for general workers, environmental health practitioners, nurses and doctors at Facilities.
Integrated Health Care Waste Management	: Is a holistic and integrated course of action that specifies the institutional, infra-structural and technological support, as well as human and financial resources required to establish and implement an integrated Health Care Waste Management Strategy.
Laboratory Waste	: Means human or animal specimen cultures from health care and pathological laboratories; cultures and stocks of infectious agents from research and industrial laboratories; wastes from the production of bacteria, viruses, or the use of spores, discarded, live and attenuated vaccines, and culture dishes and devices used to transfer, inoculate and mix cultures; and waste containing any microbiological specimens sent to a laboratory for analysis.
Landfill	: To dispose of waste on land, whether by use of waste to fill in excavations or by creation of a landform above grade, where the term 'fill' is used in the engineering sense.
Large Order	: Means a single order for supply of Disposable Containers for a particular Facility exceeding 6 month's average consumption of the Disposable Containers ordered by that Facility.

Liquid Wastes	: Any waste material, whether it being hazardous or non-hazardous and that is identified to contain "free liquids", which readily separate from the solid portion of waste under ambient temperature and pressure.
List of Health Care Facilities	: See Annexure 2 [List of Health Care Facilities] of the specifications.
Manifest System	: A system for documenting and controlling the fate of Waste from "cradle-to-grave".
Medicine	: Means any substance or mixture of substances used or purporting to be suitable for use or manufacture or sold for use in: <ul style="list-style-type: none"> • the diagnosis, treatment, mitigation, modification or prevention of disease, abnormal physical or mental state or the symptoms thereof in humans; or • restoring, correcting or modifying any somatic or physical or organic function in humans.
Monthly Waste Collection Payment	: Means: <p>(i) The total mass (excluding Disposable Container mass where applicable) of waste Collected, Transported, Treated and Disposed of, multiplied by the amounts per kg for the respective Waste Categories as indicated in the Schedule of Rates and Quantities (Applicable for all container types);</p> <p>minus</p> <p>(ii) The sum of all Penalties deductible for the relevant month (Applicable for all container types).</p> <p>For all Waste collected in Disposable Containers, Monthly Waste Collection Payment will be based on Items (i) and (ii) only.</p>
Monthly Report	: Has the meaning given to it in Section 14.2.2 of these specifications
Mobilisation Period	: Means an uninterrupted period of 30 days commencing on the Commencement of Services Date.
Non-Combustion Treatment	: Means any method, technique or process for microbial inactivation or for otherwise altering the biological, chemical or physical characteristic of Waste so as to render the Waste unrecognisable and in order to reduce the hazards it presents, and facilitate disposal by any means of technology which does not constitute controlled combustion treatment, including but not limited to autoclave treatment;
Necessary Consents	: Means all consents, licences, certificates, authorisations, permissions, approvals and permits of any Competent Authority and/or Interested Party that are necessary for the lawful performance of the Services and/or any of the Contractor's other obligations under this Contract.
Pathological Waste	: Means tissues, blood, non-viable human foetuses, and other waste from surgery and autopsies on patients with infectious diseases but excludes human teeth, hair and nails.
Penalties	: Means imposing of a financial liability on the Contractor when Service Failures occurred during the execution of the Contract that was reported by the HCW Officer of any particular Facility. Penalties are deducted from the monthly payment certificate if upheld by the Department's Representative in accordance with Section 17.5 of the Specification.
Pharmaceutical Waste	: Means pharmaceutical products and medicinal chemicals that are no longer usable in human or animal treatment, and that have become outdated, expired or contaminated or are no longer required and items contaminated with cytotoxic pharmaceuticals.
Planned Outage	: Means any shutdown or stoppage affecting the operating capacity of the Treatment Plant or any part thereof, which is planned and of which the Department's Representative has been notified in writing, no later than 1 month before its occurrence.
Pressurised Container Waste	: Includes pressurized cylinders and cartridges used in health care facilities to store gases.
Price Adjustment Factor	: Has the meaning given to it in Section 17.6 of these specifications

Province	:	Means the North West Province of the Republic of South Africa.
Radioactive Waste	:	Means liquid, solid or gaseous materials that contain, or are contaminated with, radionuclides at concentrations or activities greater than the clearance levels and for which no use is foreseen.
Registration Sheet	:	Means the documentation required for the detailed recording of Waste collection from individual Facilities during each collection round.
Residue	:	Means material, such as ash or slag, remaining after combustion or treatment of wastes or materials extracted from a liquid or gas stream.
Rollout Completion Date	:	Means the date occurring 2 months after the Commencement of Services Date.
Rollout Period	:	Means the period from the Commencement of Services Date to Rollout Completion Date.
Scheduled Substances	:	Means Medicines prescribed by the Minister of Health under Section 22A of Medicines and Related Substances Control Act, Act 101 of 1965.
Segregation	:	Means systematic separation of health care waste into designated categories.
Service Failure	:	Means the Contractor's failure to comply with certain requirements of the Contract. Service Failures are defined in Section 17.5 of the Project Specification.
Services	:	Means the services, duties and obligations to be fulfilled by the Contractor in accordance with these specifications throughout the Services Period.
Services Period	:	Means the period from the Commencement of Services Date to the expiry of the Contract.
Sharps Container	:	Means a disposable puncture resistant container which, when sealed, cannot be opened without great difficulty, and which is spill proof under normal handling conditions, used for the storage and transportation of infected sharps items.
Sharps Waste	:	Means items that could cause cuts or puncture wounds, including, but not limited to, needles, hypodermic needles, scalpels and other blades, knives, infusion sets, saws, broken glass and pipettes.
Specican Container	:	Means a disposable puncture resistant container which, when sealed, cannot be opened without great difficulty, and which is spill proof under normal handling conditions, used for the storage and transportation of infected pathological waste or waste generated in isolation wards.
Statutory Requirements	:	Means the requirements of any present or future Legislation, proclamation, by-law, directive, decision, regulation, rule, order, notice or code of practice having the force of law in the Province.
Training Programme	:	Has the meaning given to it in Section 11 of these specifications
Transporter	:	A person, organisation, industry or enterprise engaged in or offering to engage in the transportation of Waste. For the purpose of this Bid a transporter shall be registered with the North West Department of Economic Development, Environment, Conservation and Tourism, as well as the local authorities in whose area of jurisdiction it proposes to operate.
Treatment	:	Means any method, technique or process that is designed to: <ul style="list-style-type: none"> a) Change the physical, biological or chemical character or composition of waste; or b) Remove, separate, concentrate or recover a hazardous or toxic component of waste; or c) Destroy or reduce the toxicity of waste, in order to minimize the impact of the waste on the environment prior to further use or disposal.
Treatment Plant	:	Means the plant or plants used by the Contractor to Treat the HCRW.
Unit Price	:	Means the volumetric and mass price for collecting, transporting, treating and disposing of Waste, as specified in the Schedule of Rates and Quantities.

Unplanned Outage	:	Means any breakdown, stoppage, interruption, outage or cessation of, in or affecting the operating capacity of the Treatment Plant which occurs other than as a consequence of a Planned Outage.
Waste Collection Point	:	Means for each Facility, the location at which the HCRW is delivered to, by the Facilities, in Disposable Containers and where the Contractor assumes responsibility of the HCRW. The Contractor shall during its Rollout establish, in consultation with each Facility, the location of each Waste Collection Point.
Waste Information Regulations	:	Means the Regulations contemplated under the National Environmental Management Waste Act, 2008 (No. 59 of 2008).
Waste Information System	:	Means a system comprising of at least a register of the information submitted from the Contractor and the participating Health Care Facilities, in a format which is accessible to the public, and which, amongst other things, facilitates an on-line search for information pertaining to HCRW in the North West Province.
Waste Management	:	All activities, administrative and operational, associated with the handling, transport, storage, treatment and disposal of HCRW.
Waste Management System	:	Means collectively the supply of Disposable Containers, the Collection, Transport and Treatment and disposal, specified in the Project Specification.
Waste Vehicles	:	Means the vehicles used by the Contractor to transport HCRW.
Waste with Heavy Metals	:	Includes but is not limited to, mercury waste from thermometers, blood-pressure gauges, residues from dentistry; cadmium waste from discarded batteries, reinforced wood panels used in radiation proofing, and drugs containing arsenic.
Waste Act	:	Refers to the National Environmental Management: Waste Act, 2008 (Act No. 59 of 2008) as amended.

List of Acronyms

CBO	Community Based Organisation
CEO	Chief Executive Officer
CHC	Community Health Centre
CPD	Continuing Professional Development
CPI	Consumer Price Index.
DEA	Department of Environmental Affairs.
DOT	Department of Transport.
DPW	Department of Public Works
DWS	Department of Water and Sanitation
EMRS	Emergency Medical and Rescue Services
HCF	Health Care Facility
HCGW	Health Care General Waste
HCRW	Health Care Risk Waste
HCW	Health Care Waste
HC-WIS	Health Care Waste Information System
HCRWM	Health Care Waste Management
HDPE	High Density Poly Ethylene
I&AP's	Interested and Affected Parties
NEMA	National Environmental Management Act

NGO	Non-Governmental Organization
NWMS	National Waste Management Strategy
NWDOH	North West Department of Health
OHS	Occupational Health and Safety
PE	Polyethylene
PP	Polypropylene
PPE	Personal protective equipment
PPI	Production Price Index
PVC	Polyvinyl Chloride
RSA	Republic of South Africa
SA	South Africa
SABS	South African Bureau of Standards, trading as SABS
SANS	South African National Standards
WHO	World Health Organization
WIS	Waste Information System

4. Scope of supply

4.1. The Services

Technical Specifications	Comply Yes/No	Note
1. The objective of providing the services covered in this Contract is to assist Facilities in the Province in managing Health Care Risk Waste (HCRW) and to remove this HCRW from the Facilities, treat it and dispose of it.		
2. All processes and procedures required to be adopted, followed and /or implemented to ensure the safe and efficient removal of HCRW from the Facilities shall, in so far as not specifically addressed in these specifications be performed and executed by the Contractor in accordance with Good Operating and Engineering Practices, the Necessary Consents and the Statutory Requirements.		
3. The Contractor shall in the process of rendering the Services, be liable for damage done to the Department's property.		
4. The scope of supply for the Services shall for the duration of the Service Period, in general terms include the provision by the Contractor of all plant, equipment (including maintenance thereof), personnel, activities, services, know-how and expertise necessary to safely and efficiently collect all HCRW from the Waste Collection Points in the Province and treat this HCRW and dispose of the Residues at an appropriate licensed landfill.		
5. Supply and distribution of all Disposable Containers required to safely collect and remove the HCRW from all Facilities in the Province.		
6. Supply and installation of Durable Items for Disposable Containers at all Facilities in consultation with each Facility.		
7. Supply, installation and maintenance of freezers at Facilities generating Pathological Waste, or alternatively design the Collection Programme for the said Facilities to ensure that maximum allowable storage time for Pathological Waste is not exceeded.		
8. Collection of the HCRW from all public Facilities in the Province.		
9. Transportation of the HCRW from all public Facilities in the Province to the Treatment Plant.		
10. Interfacing with the Facilities in securing a safe and efficient removal of HCRW as well as the supply and distribution of Disposable Containers.		
11. Develop and accredit a HCRW Management Training Manual in consultation with the relevant SETA and provide a Training Programme accredited with the HPCSA on the management of HCRW to key staff such as EHPs and IPC Nurses at all Facilities.		
12. Provision and/or securing of sufficient and suitable treatment capacity at a Treatment Plant, together with staff, consumables, know-how and approvals necessary for Treatment of the HCRW.		
13. Treatment of all HCRW collected from the Facilities.		
14. Transport of Residues to an appropriately licensed landfill.		
15. Reporting to the Department's Representative.		
16. Convening and attending meetings and liaising with the Department's Representative.		
17. Obtaining all Necessary Consents prior to commencing the Services and maintaining such Necessary Consents throughout the Services Period.		
18. Ownership of the Durable Items will automatically be transferred to the Department.		

4.2. The Facilities

Technical Specifications	Comply Yes/No	Note
1. The Facilities to be serviced by the Contractor under this Contract are hospitals and clinics, together with other minor generators (Mortuaries, EMS and Forensic Pathology) of HCRW in the Province, operated by the North West Department of Health.		
2. The Contractor shall service all Facilities which are included in the List of Health Care Facilities.		
3. The Contractor will throughout the Contract Period have exclusive right for the supply of all Disposable Containers used for HCRW as well as the collection and treatment of HCRW generated by any of the Facilities presented in the List of Health Care Facilities, or any amended list as allowed for hereafter.		
4. Where new Facilities are commissioned or where existing Facilities are shut down, the List of Health Care Facilities can be amended by the Department during the Contract Period.		
5. The Department shall give the Contractor written notice of any amendments to the List of Health Care Facilities.		
6. The Contractor shall upon receiving such notice, liaise with Facilities added to the list and arrange with the Department and the Facility for the commencement of Services at that Facility.		
7. Likewise, the Contractor shall in consultation with the Department and the Facility terminate its Services to Facilities that may be removed from the list.		

5. The Waste

Health Care Risk Waste (HCRW) is considered to be the hazardous component of Health Care Waste (HCW) generated in both large and small health care facilities. HCRW has the potential to create a number of environmental, health and safety risks, depending on the particular HCRW category, the way in which it is handled, as well as the way in which exposure takes place.

Figure 1: Examples of Health Care Risk Waste

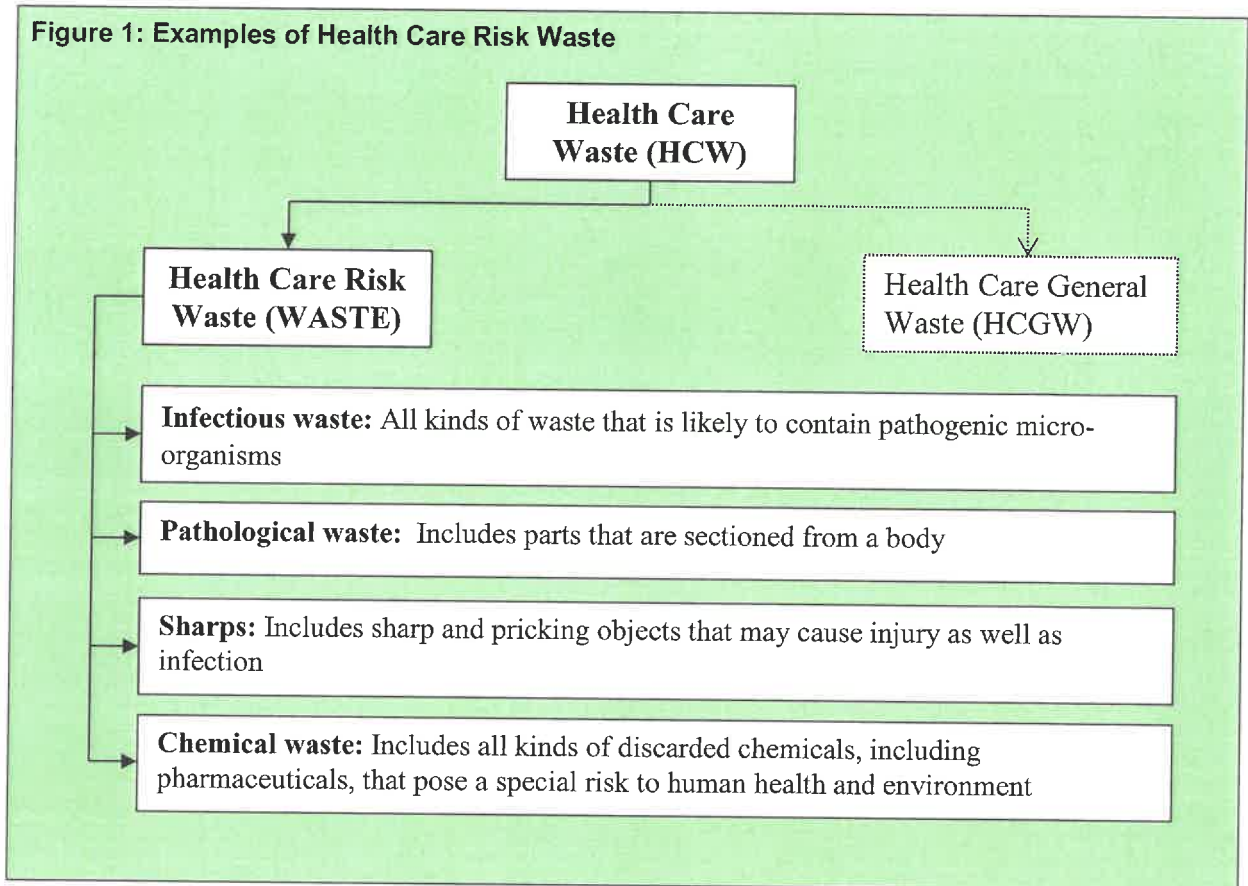

In Figure 1 above the four different categories of health care risk waste forming part of this Contract are illustrated with examples given of the most commonly found components.

Three of the components of HCRW have the potential to cause microbial contamination (infectious waste, pathological waste and sharps), but since pathological waste and sharps have additional characteristics, the containerization and treatment methods are different and therefore constitute a separate component.

Technical Specifications	Comply Yes/No	Note
1. HCRW shall, for the purpose of this Contract, be considered to include: <ul style="list-style-type: none"> a) Chemical waste; b) Cytotoxic waste. c) Genotoxic waste; d) Infectious waste; e) Isolation waste; f) Laboratory waste; g) Pathological waste; h) Pharmaceutical waste; i) Pressurized container waste; j) Sharps waste k) Soiled mattresses; and l) Waste with heavy metals 		
2. The NHLS laboratories at the Hospitals handle their own Chemical Waste, and such Chemical Waste is therefore not forming part of this Contract		

3. Extraordinary Items: The Facilities may from time to time generate large waste items that cannot be containerized and that are suspected of being infectious or that would contain hazardous chemicals. The exact nature of these items cannot be defined upfront, but it can include contaminated mattresses and mercury containing items like fluorescent tubes. This waste will form part of the Contract.		
4. Containerization of Extraordinary Items shall be arranged between the Facility and the Contractor; whenever Extraordinary Items such as soiled mattresses are collected for disposal it must be placed in a special wrapping.		
5. Sharps Waste will be containerized in disposable Sharps Containers by the staff at the Facilities and collected in the Disposable Containers prior to the Contractor assuming responsibility for the HCRW.		
6. General Infectious Waste will be collected in liners and containerized in the Disposable Containers by the Facility staff prior to the Contractor assuming responsibility for the HCRW.		
7. It is the Facility's Responsibility to containerize Pathological Waste in a Specican Container prior to the Contractor collecting the Pathological Waste. Facility staff shall further ensure that Pathological Waste containers are clearly identifiable in order to allow the Contractor to select appropriate means of treatment and disposal.		
8. In general, Chemical Waste shall be placed at the Waste Collection Point by the Facility staff in a Disposable Container marked as Chemical Waste.		
9. Pharmaceutical waste will be segregated, containerized and clearly marked according to Scheduled Substances categories as prescribed by the Minister of Health under Section 22A of Medicines and Related Substances Control Act, Act 101 of 1965, thereby enabling the Contractor to comply with the legislated requirements during the handling, treatment and disposal of Chemical Waste.		
10. Facility staff shall ensure that Chemical Waste is safely wrapped, bottled or otherwise contained, before placing it in the dark green Container.		
11. Facility staff shall ensure that Chemical Waste is labelled with identification of the substance, in order to allow the Contractor to select appropriate means of treatment and disposal.		
12. Facilities generating small quantities of Chemical Waste may place the Chemical Waste at the Waste Collection Point in a dark green Container clearly marked for Chemical Waste.		
13. Expired pharmaceuticals may already have been accumulated at some Facilities at the Commencement of Services Date. The Contractor shall collect, transport, treat and dispose of all accumulated pharmaceuticals within the first 12 months of the Services Period.		

6. Supply of Disposable Containers

Technical Specifications	Comply Yes/No	Note
1. The Contractor shall as part of its obligations, throughout the Services Period, supply and distribute Disposable Containers for each of the Facilities.		
2. Disposable Containers shall include the following: a) Sharps Containers, including containers for long sharps b) Specican Containers for Pathological Waste this includes limb bins.		

c) Pharmacan (dark green) Containers for Chemical & Pharmaceutical Waste		
d) Red liners for General Infectious Waste, including sealing mechanisms for liner		
3. Disposable and Reusable Containers shall be supplied and delivered to the Facilities by the Contractor, upon the Contractor receiving an order from the Department's Representative, specifying types and quantities.		
4. Disposable and Reusable Containers shall comply with the specifications provided in Annexure 1 [Specifications for Disposable Containers]		

6.1. Distribution of Disposable Containers

Technical Specifications	Comply Yes/No	Note
1. Except in the case of Large Orders, the Contractor shall deliver all Disposable Containers ordered to the individual Facilities within 7 working days from receipt of a written order. Failure to do so shall constitute a Service Failure.		
2. A Large Order placed by a Facility can be handled by the Contractor as a partial order, meaning that delivery can be split into several batches, insofar as sufficient supply for daily consumption by the Facility is secured.		
3. In the event of an order being handled by the Contractor as a partial order, the Contractor shall be responsible to ensure sufficient supply for daily consumption of any item(s) ordered, during the period from 2 working days after receiving a written order, until delivery of that order has been finalized.		

6.2. Brackets, Baskets and Freestanding Racks

Technical Specifications	Comply Yes/No	Note
1. The Contractor shall be responsible for supplying and installing wall mounted and nursing trolley mounted Brackets and Baskets, as well as Freestanding Racks for liners, Sharps Containers and Specican Containers.		
2. The Contractor shall during its Rollout for each Facility in the Province obtain from the Facility Manager directions on where to install such Durable Items.		
3. The Durable Items shall be manufactured in accordance with the South African Bureau of Standards.		
4. All Durable Items shall be delivered following a written order from the Facility or the Department's Representative.		
5. Once supplied and installed by the Contractor, all Durable Items shall become the property of the Department.		
6. The Contractor shall take utmost care to protect wall finishes like paint, vinyl and tiles against damage when installing the Durable Items and shall ensure that the Durable Items are properly secured.		

6.3. Disposable Containers Delivery Point

Technical Specifications	Comply Yes/No	Note
1. The Contractor shall during Rollout liaise with each Facility to establish acceptable delivery times and locations to which Disposable Containers shall be delivered.		
2. Should disposable containers be delivered during scheduled HCRW collection rounds, the contractor will be responsible to ensure that new containers are not contaminated during the transportation and delivery thereof.		

7. Collection of Health Care Risk Waste

Technical Specifications	Comply Yes/No	Note
1. The Facility is responsible for the collection and the internal transport of the containerized HCRW, from the wards and units, to the Waste Collection Point.		
2. The Contractor shall ensure that no HCRW is left unattended between the time when it is removed from the Waste Collection Point and the time when it was delivered to the Treatment Plant.		
3. The Contractor shall collect HCRW from the Waste Collection Points in accordance with the Collection Programme.		
4. The Contractor shall notify the affected Facilities and the Department's Representative of changes to the Collection Programme, 1 week prior to such changes taking effect.		
5. The Contractor shall at all times ensure that the Department's Representative as well as the respective Facilities are provided with the latest revision of the Collection Programme.		
6. HCRW collection rounds shall be undertaken between 8:00 and 15:00 on agreed days of the week.		
7. HCRW collection outside of the aforesaid hours shall only be permitted if the Contractor agrees with the Facility in writing, provided also that the Department's Representative has been informed in writing of this agreement.		
8. In order for the HCRW collection vehicle drivers to communicate with Facilities on any delays in collection times that may result from breakdowns or emergency situations, it will be expected for HCRW collection vehicle drivers to be in direct communication with Facilities or alternatively through its head office.		
9. Communication systems will be required on all HCRW Vehicles and could be in the form of cellular phones, two-way radios or similar approved.		

7.1. Waste Collection Point

Technical Specifications	Comply Yes/No	Note
1. The Waste Collection Point designates the point from where the Contractor takes responsibility for the HCRW.		
2. The Contractor shall as part of the Rollout, in cooperation with each Facility, establish the location of the Waste Collection Point(s). Facilities may due to their various sizes have more than one Waste Collection Point.		

3. The Waste Collection Point will generally be a storage room at the Facility, to which Facilities are to deliver the HCRW in Disposable Containers.		
4. Mortuaries and maternity wards will generally be the Waste Collection Points for Pathological Waste at the Hospitals.		
5. The Contractor shall during the Mobilisation Period liaise with the Department's Representative and establish the location of the Waste Collection Point(s), make arrangements for HCRW collection personnel to gain access to such Waste Collection Points, make arrangements for the installation and securing of scales (where applicable) and agree on the mass recording verification process to be followed, in accordance with these specifications during each collection round.		
6. The HCRW shall become the Contractor's responsibility once it has been removed from the Waste Collection Point		
7. Where any difficulties in terms of access to the proposed Waste Collection points may have been identified, such problems are to be reported without delay to the Department's Representative in writing.		
8. Based on such a report, the Department's Representative will in consultation with the Facility: a) identify an alternative Waste Collection Point, or b) make the necessary modifications that will ensure reasonable unobstructed access enabling collection of HCRW		
9. The Contractor shall be responsible for removing any HCRW spillage at the Waste Collection Point that may have been caused by the Contractor.		
10. Failure to remove spillage from the Waste Collection Point within 30 minutes shall constitute a Service Failure.		

7.2. Storage of HCRW

Technical Specifications	Comply Yes/No	Note
1. The HCRW can for a limited period of time be stored at the Waste Collection Point in order to make collection and transport cost effective.		
2. The Contractor shall however ensure that the following maximum storage times are not exceeded: a) General Infectious Waste: maximum storage time 7 days; b) Pathological Waste: maximum storage time 7 days if kept refrigerated at or below -2 °C, otherwise 24 hours; c) Sharps including long sharps: maximum storage time 60 days.		
3. By storage time shall be understood the time from when the HCRW is placed at the Waste Collection Point by the Facility, until it is removed from the Waste Collection Point by the Contractor.		
4. Exceeding the maximum storage times listed above shall constitute a Service Failure.		
5. The Contractor shall ensure that no HCRW is stored overnight between the time when it is removed from the Facility and the time when it is delivered to the Treatment Plant.		
6. This means that delivery of HCRW by the Contractor to the Treatment Plant shall take place on the same day that the HCRW is removed from the Facility unless it is refrigerated overnight.		
7. Failure to comply with this requirement shall constitute a Service Failure.		

7.3. Frequency of HCRW Collection

Technical Specifications	Comply Yes/No	Note
1. In addition to the requirements that maximum Waste storage times and capacity are not exceeded, the Contractor shall observe a minimum collection frequency of one week and, in the case of clinics, if stored in a freezer, one month.		

7.4. Weighing of the HCRW

Technical Specifications	Comply Yes/No	Note
1. The Contractor shall provide a suitable scale for weighing of HCRW at the time of collection from each Facility.		

7.4.1. Hospitals

Technical Specifications	Comply Yes/No	Note
1. For each Hospital, the Contractor shall procure, install and maintain a South African Bureau of Standards approved weighing scale.		
2. The scale shall be installed at or near the main Waste Collection Point.		
3. The Facility shall provide a lockable room and a permanent power supply for the scale.		
4. The scale shall be approved for commercial use and shall be calibrated by an independent and accredited party as required by the Necessary Consents and Statutory Requirements every six (6) months.		

7.4.2. Clinics and Community Health Centres

Technical Specifications	Comply Yes/No	Note
1. The Contractor shall for the Clinics and Community Health Centres provide a mobile scale for Weighing of the HCRW.		
2. The scale shall be approved for commercial use and shall be calibrated by an independent and accredited party as required by the Necessary Consents and Statutory Requirements every six (6) months.		

7.4.3. Calibration of Scales

Technical Specifications	Comply Yes/No	Note
1. All scales used for weighing the HCRW shall be approved for commercial use and shall be calibrated by an independent and accredited party as required by the Necessary Consents and Statutory Requirements every six (6) months.		
2. The HCW Officer shall have the right to verify calibration of the scale.		
3. If this verification indicates an error of more than 1%, the Department shall be entitled to demand calibration of the scale by an independent and accredited party as required by the Necessary Consents and Statutory Requirements.		

7.4.4. Weighing Discrepancies

Technical Specifications	Comply Yes/No	Note
1. The weighing of the HCRW performed at the Facility under the supervision of the HCW Officer shall form part of the basis for payment for the collection, transport, treatment and disposal of HCRW.		
2. If the Contractor detects a discrepancy of more than 2% between the scale used at the Facility and the Contractor's scale at the Treatment Plant, with such discrepancy being observed on more than one occasion, the Contractor shall immediately inform the Department's Representative about the possible causes for the discrepancy as well as the Contractor's recommendations on the way in which the problem is to be rectified.		
3. To minimize the risk of human error during mass data recording when HCRW is collected from Facilities, preference is to be given to the electronic recording and transfer of data, provided that verification and authorization of the recorded masses can still be done by the HCW Officer or its representative.		

7.5. Recording of HCRW Collected

Technical Specifications	Comply Yes/No	Note
1. The Contractor shall as part of the Services implement a recording system that will form part of the basis for payment of services rendered.		
2. For each consignment of HCRW collected, the Contractor shall issue a recording sheet containing information on: <ul style="list-style-type: none"> a) HCRW categories, i.e. General Infectious Waste, Pathological Waste, Pharmaceutical or Chemical Waste b) Time and date of collection c) Driver details d) Details of Facility representative witnessing HCRW collection 		
3. The recording sheet shall be issued in triplicate at the time and place of HCRW collection, with each copy signed by the HCW Officer and the Contractor.		
4. One signed copy of the Recording Sheet shall be retained by the HCW Officer before the Contractor leaves the Facility.		
5. The Contractor shall record the collection and Treatment of HCRW from each facility, after which a report (destruction certificate) is to be issued to certify Treatment of such HCRW.		
6. The aforesaid report is then to be submitted to the HCW Officer at that Facility, before the end of the calendar month in which the HCRW was treated.		
7. All HCRW collection recording sheets shall be triplicate carbonized copies or similar approved.		

7.6. Pathological Waste at Clinics

Technical Specifications	Comply Yes/No	Note
1. With the Clinics generating limited amounts of HCRW, the Waste collection frequency from the clinics can be less than that of the Hospitals.		
2. As this can result in maximum storage time for placentas and other pathological waste being exceeded, e.g. at Clinics with a maternity ward,		

or alternatively result in uneconomical high HCRW collection frequencies from these Clinics, the Contractor will have the option of supplying Clinics having maternity wards with freezers that can be used to store placentas if daily collection of placentas is not preferred by the Contractor.		
3. The freezers shall have a volume of 100 litres to 150 litres and shall be capable of maintaining temperatures from +0 degrees C to –12 degrees C.		
4. The freezer shall be equipped with a lock for which only the Contractor’s staff and the Clinic’s Sister in Charge shall have keys.		
5. Throughout the Service Period, the Contractor shall be responsible for all maintenance and repairs of the freezers.		
6. No additional payment will be made either for the supply of freezers, or for the increased collection frequency required to ensure the timely Treatment of Pathological Waste generated at Clinics.		
7. The Contractor must at the time of collection arrange for removal of all filled and sealed pathological waste containers from the Freezer.		

7.7. Collection of Extraordinary Items

Technical Specifications	Comply Yes/No	Note
Costing for the bid shall be all –inclusive expressed in Rands per kilogram to cover but not limited to the following in order to provide the comprehensive service and in line with the bid specification:		
1. Containerisation, Collection, Tracking, Transportation, Treatment and Disposal		
2. The Contractor shall collect Extraordinary Items for transport, treatment and disposal thereof in accordance with these specifications. These items must be weighed.		
3. Payments will be done in accordance with the kilograms of waste collected in a given month		

7.8. Mobile Clinics

Technical Specifications	Comply Yes/No	Note
1. The Contractor shall collect, transport and treat HCRW from mobile Clinics in the Province.		
2. Mobile Clinics start and finish the day at a regular Clinic. HCRW from a mobile Clinic shall be handled together with the HCRW from the regular Clinic with which the mobile Clinic is associated.		

8. Transport

8.1. Requirements for Transportation

Technical Specifications	Comply Yes/No	Note
1. The Contractor shall transport all HCRW from the Waste Collection Points at the Facilities to the Treatment Plant.		
2. The Contractor shall at all times observe the required health and safety measures and shall avoid spillage of HCRW.		
3. In the event of spillage occurring, it shall be removed by the Contractor within 30 minutes.		
4. Failure to remove any spillage shall constitute a Service Failure.		

8.2 Requirements for the HCRW Vehicles

Technical Specifications	Comply Yes/No	Note
1. The Contractor shall own/lease HCRW Vehicles for transportation of HCRW.		
2. HCRW Vehicles used by the Contractor to transport HCRW shall be for the sole purpose of transporting HCRW and may not be used for any other purpose.		
3. All HCRW Vehicles shall comply with the standards laid down by the National Road Traffic Act (Act 93 of 1996), as well as any Necessary Consent.		
4. Access to the HCRW Vehicle's loading compartment shall be safe and unobstructed, thus ensuring easy access for the Contractor's staff.		
5. Storage compartments on HCRW Vehicles shall not have any holes or openings that could result in leaking of liquids that may accidentally have spilt from containers.		
6. The inner surface of the HCRW Vehicle's storage compartment shall be smooth and rust free by being galvanised, manufactured from stainless steel or covered by zinc or other materials approved by the Competent Authorities.		
7. The internal finish of the storage compartment shall further allow for easy cleaning, e.g. angles shall be rounded, and surfaces shall be smooth, without any material joints creating the opportunity for dirt collection.		
8. There shall be a bulkhead between the driver's cabin and load compartment, designed to retain the load, in order to protect the driver, should the vehicle be involved in an accident.		
9. All HCRW Vehicles shall be equipped with emergency equipment required by the Necessary Consents.		
10. This equipment shall as a minimum include spill kits containing all personal protective equipment like masks, gloves and overalls, as well as folded HCRW containers, brooms, scoops and disinfectants, together with fire extinguishers.		
11. The staff shall be familiar with the emergency procedures whilst also trained in the effective use of such emergency equipment.		

9. Treatment of HCRW

Technical Specifications	Comply Yes/No	Note
1. The objective of treating HCRW is to deactivate the viruses, bacteria and other pathogens in the HCRW to a safe level where there is no risk of infection or other negative health impacts to humans and the environment.		
2. The treatment of HCRW shall further prevent any intentional or unintentional reuse of objects such as syringes, sharps etc. by completely or partly destroying these objects and rendering it harmless to humans and the environment.		
3. The Contractor shall treat the HCRW from all Facilities in the Province in accordance with the Regulations and the Necessary Consents.		

9.1 Requirements for Treatment of HCRW

Technical Specifications	Comply Yes/No	Note
1. Treatment is not required for Chemical Waste, provided that it is disposed of at a hazardous waste (Class A) landfill in accordance with the Norms and Standards and the Necessary Consents.		
2. HCRW other than Pathological Waste and Chemical Waste, shall be Treated by means of either Controlled Combustion Treatment or Non-Combustion Treatment		
3. Pathological Waste shall only be treated by means of Incineration Treatment.		

9.2 Handling and Storing of HCRW at the Treatment Plant

Technical Specifications	Comply Yes/No	Note
1. The procedures and equipment for unloading the HCRW shall be designed to minimize the manual handling required.		
2. The Contractor shall ensure that Pathological Waste is treated within 48 hours after it has been collected from any Facility.		
3. HCRW other than Pathological Waste shall be treated within 96 hours after it has been collected from any Facility.		
4. The time specified above is based on the rurality of the Province and the distances to the treatment facilities situated in Gauteng Province.		

9.3 HCRW Storage during a Planned Outage

Technical Specifications	Comply Yes/No	Note
1. The Contractor shall during a Planned Outage secure the use of cold storage facilities suitable for the storage of HCRW until the Planned Outage is over, or alternatively secure standby Treatment capacity at another treatment facility.		
2. The Contractor shall treat the HCRW timely in accordance with these Specifications, Norms and Standards and the Necessary Consents.		

10. Residues Disposal

Technical Specifications	Comply Yes/No	Note
1. The Contractor shall be responsible for the disposal of all Residues from the Treatment of HCRW.		
2. The Residues shall be disposed of in accordance with the Necessary Consents, the Statutory Requirements and the Waste Classification and Management Regulations, 2013.		
3. The method of transportation of the Residues selected by the Contractor shall be compatible with the type of Residues generated to ensure that no danger, nuisance or inconvenience is caused to people at or near the Treatment Plant, along any of the transportation routes or at the landfill site used for disposal of the Residues.		

4. The Contractor shall ensure that the transportation and disposal of the Residues is conducted in accordance with Good Engineering and Operating Practices.		
5. The Contractor shall meet all costs associated with the transportation and disposal of the Residues.		
6. The Contractor shall obtain a certificate from the operator of the landfill used for disposing of the Residues, stating the time, date and mass of Residues delivered to the landfill.		

11. Training Programme

Technical Specifications	Comply Yes/No	Note
1. The Contractor shall upon request by the Provincial office, hospital CEO or District Director conduct training of trainers (at the beginning of the contract.		
2. The Training shall include manuals and soft copies of presentations.		

12. Mobilization and Rollout

12.1 Mobilization

Technical Specifications	Comply Yes/No	Note
1. Following the Award of the Contract the Contractor shall have one month to mobilize its staff, plan the rollout, as well as to acquire the necessary equipment and supplies.		
2. The Mobilization Period shall further be used by the Contractor to establish communication lines with each of the Facilities as well as with the District Office and the Head Office of the Department.		
3. The Contractor shall liaise with the HCW Officer from each of the Facilities during the Mobilisation Period and agree on the programme for implementation of the new contract at the respective Facilities.		

12.1.1 Rollout Plans

Technical Specifications	Comply Yes/No	Note
1. A District Rollout Plan is covering all facilities within a district, indicating how the process will be executed over the 2-month Rollout Period, and when the various Facilities can expect to become involved in the Rollout process.		
2. The District Rollout Plan is to be approved by the Department's Representative in Head Office and District Chief Directors, as it will impact on the district as a whole.		
3. If no comments were received within 10 working days from submission of any District Rollout Plan, it will be assumed that the plan was approved as is.		

4. The Contractor shall develop a District Rollout Plan for the Rollout Period inter alia containing the following: a) Names and contact details of HCW Officers from each Facility; b) Programme for the Rollout Period, specifying for each Facility the dates for the start and completion of the Rollout; c) Details on number and types of Durable Items that is to be supplied to and fitted in each Facility; d) Type of mass recording system to be implemented and/or installed for each Facility; e) Training of Department's staff responsible for HCRW management at Contractor's expense; f) Details of the Contractor's staff, that will be responsible for the training; g) Details of container delivery and HCRW collection procedures, including data collection, recording and tracking system; h) Details of Facility specific problems and opportunities encountered during the planning of the Rollout Period together with proposed solutions; i) Development of site-specific backup procedures and emergency plans for implementation inter alia in the event of vehicle or plant breakdowns or accidents.		
5. In addition to the District Rollout Plan, Facility Rollout Plans with more detailed information is to be developed for each of the respective Facilities.		
6. The purpose of the detailed Facility Rollout Plans is not only to ensure that the Contractor undertakes sufficient and accurate planning, but also to ensure that the Facility is in agreement with the detailed Facility Rollout Plan.		
7. To ensure that staff will be available at the respective times indicated for training in the Rollout Plan, it is important that the Facility Rollout Plans be developed in consultation with the respective Facilities, after which it is to be approved by the CEO or Facility Manager of that particular Facility.		
8. The Facility Rollout Plan shall be deemed approved by the CEO or Facility Manager if the Contractor has not received a response from the CEO or Facility Manager within 10 working days after submitting the Facility Rollout Plan to the CEO or Facility Manager.		
9. The District and Facility Rollout Plans shall be submitted to the Department's Representative no later than 21 days after the start of the Mobilization Period.		
10. Implementation of the Rollout Plan shall be subject to the Department's approval of the Plan.		
11. The Rollout Plan shall be deemed approved by the Department if the Department fails to respond to the Contractor within one week of receiving the proposed Rollout Plan.		

12.2 Rollout Period

Technical Specifications	Comply Yes/No	Note
1. The Contractor's obligations during Rollout at each Facility shall comprise: a) Liaising with HCW Officers and Facility management to keep them informed of plans, programmes and progress throughout the Rollout Period; b) Surveying each Facility to determine quantities and types of Durable Items and Disposable Containers needed;		

<ul style="list-style-type: none"> c) Installation of Durable Items for Disposable Containers in the wards, on nursing trolleys etc, as agreed in writing by the HCW Officer; d) Implementation of the Training Programme; e) Supply and installation of freezers where applicable; f) In cooperation with the HCW Officer ensure that an appropriate Waste Collection Point is available. The Contractor shall where necessary, suggest any modifications or installations that may be required at the Waste Collection Points in order for the Contractor to fulfil its obligations; g) Submitting to the HCW Officer, with a copy to the Department's Representative, a programme for the collection of HCRW from the Facility. The programme shall specify the specific weekdays and approximate times on which HCRW is to be collected; h) Supply and installation of scales where applicable; i) Supply and monitoring of distribution of Disposable Containers; j) Implementation of HCRW recording and tracking systems; k) Testing of site-specific backup procedures and emergency plans developed for implementation inter alia in the event of plant or vehicle breakdowns or accidents. 		
---	--	--

12.4 Consultancy during the Rollout Period

Technical Specifications	Comply Yes/No	Note
<p>1. The Contractor shall, as part of its responsibilities during the Rollout Period, perform the following Consultancy activities:</p> <ul style="list-style-type: none"> a) Promote the SABS Codes of Practice for HCRW management; b) Ensure that decisions taken reflect the standards laid out in the SABS Codes of Practice for HCRW management through a consultative process; c) Ensure that all new equipment is properly positioned and used; d) Assist Facilities to determine appropriate internal collection routines for high and low risk areas; e) Advise Facilities on the use of intermediate and central storage areas, as well as any modifications or upgrading of such stores that may be required; f) Liaise with the Facilities regarding waste collection times and Disposable Container delivery times (if different) by the Contractor; g) Provide support with the mass measurement for HCRW as well as data recording for billing and HCRW tracking respectively; h) Advise on specifications for other equipment to be acquired by Facilities such as Personal Protective Equipment (PPE); i) Set up regular internal performance and equipment monitoring programmes for implementation by health care workers; j) Advise Facilities on HCGW management matters in as far as it will impact on HCRW management. 		

13. Handover of Services

Technical Specifications	Comply Yes/No	Note
<p>1. When the Contract Period is approaching its end, the Contractor shall liaise with the Department's Representative and the new contractor that will take over the Contractor's responsibilities, with the objective of ensuring a smooth and efficient transition of responsibilities to the new contractor.</p>		

2. The Handover Period is the last 2 months of the Contract Period.		
3. The Contractor shall during the Handover Period liaise with the Facilities and ensure that available stocks of Disposable Containers are no more than one month's normal consumption for each individual Facility.		
4. The Contractor shall, no later than the first day in the Handover Period, submit the following to the new contractor: a) Lists with names and contact details of all HCW Officers for the respective Facilities in that particular District; b) Lists with details on all Waste Collection Points; c) Most recently updated Collection Plan; d) Details of route planning for the Contractor's Waste Vehicles; e) Inventory of types and numbers of Durable Items deployed in each Facility; f) Statistics on average monthly consumption for each of the different Disposable Containers supplied to the respective Facilities.		

14. Communications

14.1 Meetings

Technical Specifications	Comply Yes/No	Note
1. Fortnightly Project Meetings will be held between the Department's Representative and the Contractor during the Mobilization and Rollout period.		
2. Thereafter the Project Meetings between the Department's Representative and the Contractor will be held monthly (or as agreed) for the remainder of the Contract Period.		

14.2 Reporting

Technical Specifications	Comply Yes/No	Note
1. The requirements for reporting to be fulfilled by the Contractor shall comprise preparing and delivering to the Department's Representative: a) Copies of all reports required by the Necessary Consents; b) Annual Reports; c) Monthly Reports; d) Incident Reports; e) HCRW Information Reports.		
2. HCRW Information Reporting shall be in accordance with the Service Level Agreement to be entered into between the Contractor and the North West Department of Health.		

14.2.1 Annual Report

Technical Specifications	Comply Yes/No	Note
1. An Annual Report, primarily consisting of a summary of the monthly reports, is to be prepared and delivered to the Department's Representative.		

2. The following is to be used as an outline of the issues to be addressed in annual reports, where it was not already included in the monthly reports.		
3. The Contractor shall ensure that each Annual Report shall, at minimum, contain the following information:		
4. Special events (events that have influence on the Contractor's obligations), i.e. a) Failures by the Department or other parties, e.g. late payments; b) The Contractor's Services Failures including the summary of Penalties imposed during the relevant year.		
5. Organization: a) Key Personnel; b) Other staff; c) Subcontractors; d) Suppliers; e) Changes in organization.		
6. Health and Safety: a) Summarised outcome of medical examinations undertaken on staff; b) Vaccination programme; c) Antiretroviral treatment programme; d) Accident report and measures taken to prevent a reoccurrence thereof; e) Supply and usage of Personal Protective Equipment (PPE); f) Compliance with the Occupational Health and Safety Act (Act 85 of 1993).		
7. Operational report: a) A record of the Durable Items installed and maintained for each of the Facilities; b) A record of the Disposable Containers delivered with information on type and numbers for each Facility; c) A record of the HCRW collected with information about weight and volume for each HCRW category collected from the various Facilities in the Province, as well as details on the destination of the HCRW; d) Graphs indicating container supply trends on a monthly as well as an annual basis (based on all previous information generated under this Contract); e) Graphs indicating HCRW generation trends on a monthly as well as annual basis (based to all previous information generated under this Contract); f) A record of the various HCRW categories treated, and Treatment Plants used with information about mass and volume for each type of HCRW and destination of the Residues; g) Graphs indicating treatment trends on a monthly as well as an annual basis for each HCRW Category (based on all previous information generated under this Contract); h) HCRW generation rates per patient-day; i) Management of specialised HCRW streams, e.g. Pathological Waste, Chemical Waste, Extraordinary Items, etc.; j) Overview of strengths and weaknesses in Disposable Container ordering and delivery system; k) Overview of strengths and weaknesses in HCRW collection and transport; l) The Contractor's Services Failures including a summary of Deductions imposed during the year under consideration; m) Operational failures by interfacing parties like subcontractors and suppliers;		

n) Operational failures by the Department, e.g. late payments; o) Operational failures by Facilities, e.g. overloading of containers.		
8. Financial Report: a) A financial review of expenditure during the previous year broken down according to different Facilities, different components of services, etc.; b) Price Adjustment Factors during the previous year; c) Advice on actual and anticipated cash flow for each Facility.		
9. Environmental Report: a) Documentation of compliance with the Regulations by means of verified documentation.		
10. The annual report shall be submitted to the Department's Representative in final draft no later than 1 month after expiry of the previous calendar year.		
11. The first Annual Report shall cover the period from Commencement of Services Date to the end of the calendar year in which the Commencement of Services Date occurs.		

14.2.2 Monthly Report

Technical Specifications	Comply Yes/No	Note
1. The Contractor shall prepare and issue a Monthly Report, which shall be submitted electronically to the Department and to the Department's Representative and in original by courier/mail to the same.		
2. In case of deviations between these two versions, the original submitted by courier/mail shall prevail.		
3. Each Monthly Report during the Services Period shall cover one Month and start on the 1st day of such month.		
4. The first Monthly Report shall cover the period from the Commencement of Services Date up to the end of the calendar month in which the Commencement of Services Date occurs.		
5. In any event each Monthly Report shall inter alia include: a) A record of the Durable Items installed and maintained for each of the Facilities; b) A record of the Disposable Containers delivered with information about type and quantity for each Facility; c) A record of the HCRW collected with information on weight and volume for each category of HCRW collected from the various Facilities, as well as the destination of such HCRW; d) A financial review to include cash flow for each Facility; e) Advice on problems encountered specifically as they relate to the standards and quality of Services; f) Advice and directives required from the Department and/or the Department's Representative; g) A summary of incident reports submitted during the previous month, as well as the measures taken to rectify the situation and to prevent a reoccurrence of such incidents; h) Any health and safety matters; i) Any environmental matters.		
6. The Monthly Report shall be attached to the invoice for the Monthly HCRW Collection Payment for the month to which such Monthly Report relates.		

14.2.3 Incident Report

Technical Specifications	Comply Yes/No	Note
1. Incident reports shall be issued by the Contractor to the Department's Representative in the event of any emergency leading to accumulation of HCRW at any Facility or Treatment Plant, other events that affect the obligations of the Contractor or the Department under this Contract, as well as health and safety related incidents.		
2. The contents of incident reports cannot be foreseen at this stage, but the purpose of each incident report shall be to keep the Department's Representative fully updated and informed of all activities and actions concerning the emergency.		
3. Incident reports will further be used for immediate and detailed reporting on any accidents that impacted on the health and safety of people, as well as environmental situations that created a risk of pollution.		
4. Incident reports shall be forwarded in electronic form to the Department's Representative by no later than noon the following day, with hard copies formally submitted within 7 working days thereafter.		

14.3 Inspections

Technical Specifications	Comply Yes/No	Note
1. The Contractor shall at all times provide the Department's Representative and/or any HCW Officer, with adequate and prompt assistance in the execution of their duties of monitoring and inspecting the Service delivery.		
2. To this end experienced personnel shall be available on request to assist the Department's Representative and/or HCW Officer.		
3. The Contractor shall also provide the Department's Representative or any HCW Officer, with safe access for inspection of any location or vehicle used by the Contractor to render the Services.		
4. The Department's Representative as well as the HCW Officers shall act reasonably and coordinate their activities with the Contractor's routine wherever appropriate and possible.		

15. Backup Arrangements

Technical Specifications	Comply Yes/No	Note
1. Without prejudice to any other obligation or liability of the Contractor under this Contract, if at any time during the Services Period the Contractor is prevented from processing HCRW at the Treatment Plant due to the occurrence of an Unplanned Outage, then the Contractor shall invoke the backup arrangements in the period from the date of commencement of the Unplanned Outage until the date and time of cessation of such Unplanned Outage.		
2. The backup arrangements shall ensure that HCRW is stored in a manner avoiding odour problems as well as health and safety hazards and in accordance with the Necessary Consents, by: <ul style="list-style-type: none"> a) Procuring the use of cold storage facilities that are suitable for the storage of HCRW, with the purpose of storing the HCRW until the cessation of the Unplanned Outage, proof thereof to be attached, or by; 		

b) Procuring the use of an alternative treatment facility until the cessation of the Unplanned Outage, proof of agreement to be attached.		
3. An Unplanned Outage with a duration exceeding 2 weeks will be considered to be a Service Failure.		
4. An Unplanned Outage occurring less than 3 months after the previous Unplanned Outage shall constitute a Service Failure regardless of the duration of such Unplanned Outage.		
5. The Contractor shall further prevent a backlog in the supply and delivery of Disposable Containers, as well as prevent a build-up of HCRW at any of the Facilities, due to unforeseen breakage of HCRW collection vehicles, by: a) Ensuring access to and securing the use of additional HCRW collection vehicles that are in compliance with these Specifications; b) Increasing the container delivery and HCRW collection shifts to the extent that all deliveries and collection is in accordance with the approved schedule, provided that this arrangement is conveyed to and agreed by the Facilities to ensure the availability of staff at the Facilities for the verification of containers delivered and HCRW collected.		
6. The availability of backup HCRW vehicles during routine maintenance of the HCRW Collection fleet would not be considered justification by the Contractor for requesting increased HCRW collection shifts from the Facilities.		
7. Labour unrest or strikes shall not be considered to be reason for any shortage in the delivery of disposable containers, or any build-up of HCRW at the Facilities, or alternatively any backlog in the treatment of HCRW at the Treatment Facility.		
8. The cost of making the required backup arrangements and facilities available is to be included in the unit price for the collection and treatment of HCRW and the Department will not be liable for any additional payments resulting from the provision, implementation or use of backup arrangements or facilities.		

16. Health and Safety

Technical Specifications	Comply Yes/No	Note
1. The Contractor is to familiarize itself and comply with all safety regulations and statutes governing HCRW management activities.		
2. The safety of the Contractor's personnel, its subcontractor's personnel, as well as that of Facility staff members or members of the public affected by the execution of the Services, shall be the sole responsibility of the Contractor.		
3. The Contractor is to submit copies of its Operational Health and Safety Plan that shall be designed to ensure the health and safety of any persons involved in or affected by the management of HCRW.		
4. The Contractor will be liable for any damage to property or injury to the Contractor's personnel, its subcontractor's personnel, and personnel from other contractors, Facility staff members or members of the public, resulting from any activities related to the collection and removal of HCRW from Facilities by the Contractor.		
5. General compliance with the stipulations of the Occupational Health and Safety Act and Regulations (Act 85 of 1993), and in particular with Section 37 (2), will be required throughout the Contract Period.		

6. The Contractor shall in its Health and Safety Plan describe the vaccination programme that is implemented for all workers, as well as the antiretroviral treatment that will be available to workers in the event of needle stick injuries.		
7. Daily records of the Contractor's, as well as subcontractor's, employees' HCRW handling operations should be kept and all occupational health and safety incidents that may have been experienced during the day are to be reported, particularly with respect to any needle stick injuries or other abrasions of the skin.		
8. The Contractor shall ensure that all employees and subcontractor's employees (whether permanent or temporary) are adequately insured. No untrained persons shall be allowed to carry out any work under this Contract.		

17. Payment for Services and Supplies

Technical Specifications	Comply Yes/No	Note
1. In consideration of the Contractor providing the Services in accordance with the terms of this Contract the Department shall, throughout the Services Period, pay the Contractor in accordance with the provisions of Section 17.2 below.		
2. The Contractor shall receive payment for the following separate items: a) Supply and distribution of Disposable Containers (by order); b) Supply, distribution and installation of Durable Items and for Disposable Containers (by order/mutual agreement); c) Collection, transport, Treatment and disposal of the HCRW (monthly); d) Training activities and consultancy support (quarterly).		
3. Invoicing shall be presented in accordance with the items and rates indicated in the Schedule of Rates and Quantities.		

17.1 Supply and Distribution of Disposable Containers

Technical Specifications	Comply Yes/No	Note
1. Disposable Containers shall be ordered by the respective HCF's and shall be invoiced by the Contractor for each order.		
2. Invoices are to be submitted to the respective HCF's once Disposable Containers are delivered to the Facilities in accordance with the relevant orders.		

17.2 Collection, Transport, Treatment and Disposal of the Health Care Risk Waste

Technical Specifications	Comply Yes/No	Note
1. In consideration of the Contractor collecting, transporting, treating and disposing of the HCRW, the Department shall pay the Contractor an amount representing the Monthly Waste Collection Payment in respect of each month.		

<p>2. The Monthly Waste Collection Payment shall be calculated as:</p> <p>a) The total mass of HCRW collected, transported, treated and disposed of, multiplied by the amounts per kg for the respective HCRW categories as indicated in the Schedule of Rates and Quantities (Applicable for all container types);</p> <p>b) minus</p> <p>c) The sum of all penalties deductible for the relevant month (Applicable for all container types).</p>		
<p>3. For all HCRW collected in Disposable and non-disposable containers, Monthly Waste Collection Payment will be based on Items (i) and (ii) only.</p>		

17.3 Supply, Distribution and Installation of Durable Items

Technical Specifications	Comply Yes/No	Note
<p>1. The Contractor shall receive payment for the supply and installation of Durable Items during the Rollout Period.</p>		
<p>2. Durable Items supplied to any Facility after the Rollout for that Facility is finalised, shall be invoiced following the delivery.</p>		

17.4 Extraordinary Items

Technical Specifications	Comply Yes/No	Note
<p>1. At the request of a Facility, the Contractor shall submit to the Facility a price for removing a batch of Extraordinary Items. In compliance to 7.7</p>		
<p>2. The price shall be reasonable and fair and shall reflect the actual costs incurred for the Contractor to collect, transport, treat and dispose of the particular Extraordinary Item.</p>		
<p>3. The Contractor shall invoice the collection, transport, treatment and disposal of extraordinary items, separately.</p>		

17.5 Penalties

Technical Specifications	Comply Yes/No	Note
<p>1. If a Service Failure occurs, a penalty equal to the amount set out opposite such Service Failure in the following table will be deducted from the relevant Monthly Waste Collection Payment, in respect of each such Service Failure when calculating the Monthly Waste Collection Payment.</p>		
<p>2. Penalties for Service Failures will be invoked by the HCW Officer of the Facility affected by the Service Failure.</p>		
<p>3. Where the Contractor believes that the Service Failure for which he/she is penalized was as a result of circumstances or conditions beyond his/her control, a written submission can be made to the Department's Representative.</p>		
<p>4. Having investigated the matter, the Department's Representative will make a ruling on the matter as to whether the penalty will be upheld, or whether it is to be waived.</p>		
<p>5. Should the Contractor not be satisfied with the ruling of the Department's Representative, the Contractor has the right to take further action for</p>		

dispute resolution as allowed for in the General Conditions of Bid, Contract and Order.		
---	--	--

Ref	Service Failure	Penalty amount (VAT and escalation excluded)
6.1	The Contractor fails to supply a Facility with Disposable Containers that are compliant with this Specification, within 7 days of the Contractor receiving an order for such Disposable Containers.	R 2 000-00 per incident.
15	The duration of an Unplanned Outage exceeds 2 weeks, or such Unplanned Outage is occurring more than once in every 3 months.	R 2 000-00 per day that the duration of the Unplanned Outage exceeds 2 weeks.
7.1	The Contractor fails to remove a spillage within 30 minutes at a Waste Collection or loading Point.	R 1 000-00 per incident.
7.2	The Contractor fails to remove HCRW from the Waste Collection Point within the maximum allowable storage time of that HCRW being placed at the Waste Collection Point, or exceeding the frequency allowed for that particular Facility.	R 1 000-00 per day for clinics, and R 3 000-00 per day for hospitals.
7.2	The Contractor Fails to deliver HCRW to the Treatment Plant the same day it has been removed from a Facility unless it was refrigerated overnight.	R 2 000-00 per incident.
8.1	The Contractor fails to immediately remove a spillage that occurred during transportation of HCRW.	R 5 000-00 per incident

17.6 Adjustment of Prices and Penalties

Technical Specifications	Comply Yes/No	Note
1. The Contractor shall be allowed to adjust the prices of services and supplies once per year, i.e. at twelve monthly intervals.		
2. The price adjustment shall be instituted by calculating a Price Adjustment Factor.		
3. The Price Adjustment Factor shall be calculated in accordance with the Consumer Price Index (CPI), using the Core Inflation Rate (CIR).		
4. The base date of the Price Adjustment Factor shall be the Commencement of Services Date.		
5. The Price Adjustment Factor for a 12-month period shall be calculated as the CIR on the first day of that 12-month period, divided by the CIR on the Commencement of Services Date.		
6. The Price Adjustment Factor shall apply to both offered rates as well as Penalties.		
7. If the indices for the Core Inflation Rate relevant to any particular certificate are not known at the time when the certificate is prepared, the Department shall estimate the value of such index.		
8. Any correction, which may be necessary when the correct indices become known, shall be made in subsequent payments.		

ANNEXURE 1: SPECIFICATION FOR DISPOSABLE AND NON-DISPOSABLE CONTAINERS

Although Bidders are allowed to submit indicative samples and are not required to submit actual prototypes of the Disposable Containers at the time of Bid, such samples will be used for verification of features and quality standards until such time that actual prototypes are submitted for approval after award of Contracts to successful Bidders.

A1.1: Sharps Containers

Due to the different rates at which infected sharps are generated as well as the particular requirements for different applications of Sharps Containers, there is a need for a range of Sharps Containers to be made available to the Facilities, leaving it up to the respective Facilities to make a decision on the type of container that would best meet their particular needs.

The risk of physical injuries and infection from sharp objects used in hospitals and clinics is high, resulting in a need for Sharps Containers to meet certain minimum standards in terms of user friendliness, robustness and also the effort required for people to gain access to, or come into contact with sharps previously disposed of.

The following requirements are to be met in the supply of Sharps Containers:

A1.1.1 Range of Sharps Containers required:

1. The following generic types of Sharps Containers must, as a minimum form part of the supply made available for ordering by the Facilities:
 - (a) Type A: 1-4 litre sharps container;
 - (b) Type B: 4-8 litre sharps container;
 - (c) Type C: 8-15 litre sharps container;
 - (d) Type D: 15-25 litre sharps container;
 - (e) Type E: Tall slim sharps container with a minimum height of 600 mm and capacity of between 5 litres and 10 litres for long sharps.
2. A minimum of one Sharps Container of type B or type C must be of the horizontal loading type.

A1.1.2 Material to be used in manufacturing of Sharps Containers and mounting Brackets:

1. Sharps Containers must be manufactured from polypropylene (PP) or alternatively polyethylene (PE); SANS 10248-1:2008 and SANS 452:2008
2. The material shall be puncture resistant as per the SANS Code 10248 Sharps Container requirements;
3. Ink colours and dye must be free of heavy metals;
4. Sharps Container Brackets for wall or nursing trolley mounting of containers are to be manufactured from mild steel and stainless steel respectively as indicated in Schedule of Rates and Quantities;
5. Sharps Container Brackets are to be powder coated or galvanised when manufactured from mild steel. No coating is required for stainless steel Brackets.

A1.1.3 Sharps Container Design Requirements:

1. Sharps Containers shall be rigid, puncture resistant, leak resistant, tamper proof and clearly marked as described below;
2. The required colour coding for Sharps Containers is yellow in accordance with SANS 10248.
3. Parts of the Sharps Container shall be fully or partially transparent to allow for assessment of level of filling or contents. Alternatively, it shall be possible to assess the degree of filling or contents through the aperture/opening;
4. Sharps Containers shall be designed to allow for disposal of needle and syringe as one unit;
5. Sharps Containers shall include apertures for the safe removal of sharps/needles from syringes/tubing etc. including "butterfly" type needles on tubes, using a one-handed technique;
6. Sharps Containers shall be designed to avoid overfilling and protruding sharps;
7. Sharps Containers shall in their dimensions facilitate best possible usage of the available volume, i.e., rectangular plan cross section for parallel packed placing of syringes and other sharps are preferred to circular or oval plan cross sections;
8. Sharps Containers shall allow for nesting in the unassembled state for effective transport and storage of empty containers;
9. Sharps Containers shall be stackable in the assembled state and preferable in modular fashion for the different sizes of containers to allow for effective storage and transport of full containers;
10. Sharps Containers shall allow for easy and safe assembling (e.g. fitting the lid part onto the container part of the Sharps Containers);
11. The (a) lid and (b) opening closure of a Sharps Container shall ensure that the lid and opening closure cannot be released after installation and sealing respectively through the introduction of a non-reversible sealing design;
12. Types D and E Sharps Containers shall be equipped with a foldaway handle for safe handling and transport of containers;
13. The mechanical stability of the empty as well as full Sharps Containers, when standing and whilst being moved or transported, shall be ensured for all Sharps Containers, with the exception of the Type E containers for which this requirement will only apply when standing in a static state;
14. Sharps Containers shall be designed to reduce the risk of spillage of contents in the event of tipping or dropping of Sharps Containers, preferable by an automatic obstruction of the aperture when not in the upright position.

A1.1.4 Sharps Container Markings:

1. A label shall be as located on the Sharps Containers as to be clearly visible when stacked with other packaging;
2. Sharps Containers shall include suitable warning signage, the international biohazards symbol and relevant UN codes as recommended by the World Health Organisation (WHO), together with the text "Infectious Sharps for Destruction" or similar text clearly readable and identifiable with a font set suitable for the type and size of the container;
3. Lettering on the label shall contrast with the background of the label, be of one size, style and layout that will result in the marking that is clearly readable;
4. The background of the label shall be of the colour that contrasts with the surface area immediately surrounding the label;
5. All text shall as a minimum be in the English language and preferably in one or more of the other official South African languages;
6. Sharps Containers shall be equipped with a maximum filling line that protects against overfilling. The placement of the max fill line shall as a minimum be 35-mm below the level of the aperture of the container;

7. The sizes of hazard labelling shall be as specified in SANS 10248:

Net volume of containers (litre)	Minimum Label Size (mm)
≤ 0,5	15 x 15
> 0,5 but ≤ 5	20 x 20
> 5 but ≤ 20	30 x 30
> 20	100 x 100

A1.1.5 Sharps Container Mounting Brackets:

Note: The Sharps Container Mounting Bracket designs as illustrated in Figure 2 of this Annexure are typical of those used during the pilot studies. Although Bidders are invited to propose any alternative design, the aforesaid are indicative of the type of Brackets that will be required.

1. Sharp containers Type B, C and E should be compatible with wall mounting Brackets (Fig. A 1.1), with Type B also being compatible with Brackets that can effectively be hanged or clipped onto nursing trolleys (Fig. A 1.2) to ensure safe positioning of containers during use.
2. Brackets must as a minimum comply with the following specifications:
 - (a) Brackets must be strong and robust and have a serviceable life of at least 5-years under normal working conditions. Any Brackets that are not fully functional for the aforesaid service life are to be replaced by the contractor at any time during the contract period without any additional compensation;
 - (b) Brackets shall be grey or off-white coloured and shall be powder coated;
 - (c) Brackets shall be smooth at all surfaces and free from cutting splinters, welding residues etc. that may cause abrasions to the hand or similar;
 - (d) Brackets shall be easy to clean with no exposed areas being unreachable during usual cleaning operations.

A1.1.6 Quality Control Requirements:

1. Sharps Containers shall be able to pass a drop test in accordance with United Nations Recommendations on the Transport of Dangerous Goods, Chapter 6 with particular reference to paragraphs 6.1.5.3 to 6.1.5.6. The Contractor shall verify this by submitting to the Department's Representative a report on the said drop test, carried out by an independent institution like the SABS.

A1.2: Specican Containers

Different applications and rates of Waste generation, will require that a range of Specican Containers be made available to the Facilities, leaving it up to the Facilities to make a decision on the type of container that would meet their particular needs best.

The risk of physical infection from blood and Pathological Waste generated in hospitals and clinics is high, resulting in a need for Specican Containers to meet certain minimum standards in terms of user friendliness, robustness and also the effort required for people to gain access to, or come into contact with infectious Waste previously disposed of.

The following requirements are to be met in the supply of Specican Containers:

A1.2.1 Range of Specican Containers required:

1. The following generic types of Specican Containers must, as a minimum form part of the supply made available for ordering by the health care institutions:
 - (a) Type F: 8-15 litre Specican Container;
 - (b) Type G: 15-25 litre Specican Container;
 - (c) Type H: 40-70 litre sealable isolation ward container suitable for all waste from isolation wards as well as certain amputations. Type H containers must have an opening of at least 800 cm² and no side of the aperture may be less than 250 mm should the opening be rectangular/polygonal;
 - (d) Type I: 80-100 litre, 650 mm tall, 350 x 400 mm diameter that is suitable for limbs.

A1.2.2 Material to be used in manufacturing of Specican Containers and mounting Brackets:

1. Specican Containers must be manufactured from high-density polyethylene (HDPE), thus being able to withstand temperatures as low as -5°C for cold storage of pathological waste;
2. The material shall be puncture resistant in accordance with the SANS Code 10248;
3. Printing colours and dies must be free of heavy metals;
4. All Specican Container Brackets for wall mounting of containers are to be manufactured from mild steel and stainless steel respectively as indicated in Schedule of Rates and Quantities;
5. Specican Container Brackets are to be powder coated or galvanised when manufactured from mild steel. No coating is required for stainless steel Brackets.

A1.2.3 Specican Container design requirements:

Types D and E Sharps Containers shall be equipped with a foldaway handle for safe handling and transport of containers;

1. Specican Containers shall be rigid, leak resistant, puncture resistant, tamper proof and clearly marked as described below;
2. Specican Containers shall be designed to reduce the risk of spillage and ensure that any moisture or liquid is safely contained;
3. Specican Containers with lids shall be designed so that it has a two-staged closure, with the first stage preventing the emission of odours, but still allowing the Specican Container to be opened. Once the lid is however firmly closed by means of a non-reversible sealing design in the second stage, it should not be possible to be reopened;
4. Specican Containers must allow for the use of a seal that could also be used for identification, whilst providing evidence of tampering/opening;
5. The required colour coding for Specican Containers is red, with red lids when used for pathological waste;
6. Parts of the Specican Container shall be fully or partially transparent to allow for assessment of level of filling or contents, provided that this will not in any way impact on the strength or the leak resistance of the container.
7. The Specican Containers Type F and G shall in their dimensions facilitate best possible usage of the available volume, i.e., rectangular plan cross section are preferred to circular or oval plan cross sections;
8. Specican Containers shall allow for nesting in the unassembled state for effective transport and storage of empty containers;
9. Specican Containers shall be stackable in the assembled state and preferable in modular fashion for the different sizes of containers to allow for effective storage and transport of full containers;

10. Specican Containers shall allow for easy and safe assembling (e.g. fitting the lid part onto the container part of the Specican Containers);
11. Types F, G, H and I Specican Containers shall be equipped with a handle for safe lifting and transport of containers;
12. The empty as well as full mechanical stability of the Specican Containers, when standing and while being moved or transported shall be ensured;
13. Specican Containers shall be designed to reduce the risk of spillage of contents in the event of tipping or dropping.

A1.2.4 Specican Container markings:

1. A label shall be as located on the Specican Containers as to be clearly visible when stacked with other packaging;
2. Specican Containers shall include suitable warning signage, the international biohazards symbol as detailed in SANS 10248, together with the text "Biohazardous Waste for Destruction" or similar text in clear readable letters;
3. Lettering on the label shall contrast with the background of the label, be of one size, style and layout that will result in the marking that is clearly readable;
4. The background of the label shall be of the colour that contrasts with the surface area immediately surrounding the label;
5. All text shall as a minimum be in the English language and preferably in one or more of the other official South African languages;
6. The sizes of hazard labelling shall be as specified in SANS 10248:

Net volume of containers (litre)	Minimum Label Size (mm)
≤ 0,5	15 x 15
> 0,5 but ≤ 5	20 x 20
> 5 but ≤ 20	30 x 30
> 20	100 x 100

A1.2.5 Specican Container Mounting Brackets:

Note: The Specican Container mounting Bracket designs as illustrated in Figure 2 of this Annexure are typical of those used during the pilot studies. Although Bidders are invited to propose any alternative design, the aforesaid are indicative of the type of Brackets that will be required.

1. Specican Container Type F should be compatible with wall mounting Brackets to ensure safe positioning of containers during use.
2. Brackets must as a minimum comply with the following specifications:
 - (a) Brackets must be strong and robust and have a serviceable life of at least 5-years under normal working conditions. Any Brackets that are not fully functional for the aforesaid service life are to be replaced by the contractor at any time during the contract period without any additional compensation;
 - (b) Brackets shall be grey or off-white coloured and shall be powder coated, or similar smooth and easy to clean surface that is durable;
 - (c) Brackets shall be smooth at all surfaces and free from cutting splinters, welding residues etc. that may cause abrasions to the hand or similar;
 - (d) Brackets shall be easy to clean with no exposed areas being unreachable during usual cleaning operations;
 - (e) Wall plates for all Disposable Container brackets and baskets shall be of uniform design with a standard screw pattern that would allow for the interchange of brackets or baskets without the need for any modification to the drilled holes or wall plugs.

A1.2.6 Quality Control Requirements:

- Speciman Containers shall be able to pass a drop test in accordance with United Nations Recommendations on the Transport of Dangerous Goods, Chapter 6 with particular reference to paragraphs 6.1.5.3 to 6.1.5.6. The Contractor shall verify this by submitting to the Department's Representative a report from the said drop test, carried out by an independent institution like the SABS.

Container Type.	Sharps Container.	Sharps Container.	Sharps Container.	Sharps Container.	Sharps Container.	Tall Sharps Container.	Speciman.	Speciman.	Speciman.	Limb Speciman.
Container Category	A	B	C	D	E	F	G	H	I	
Capacity (litre)	1-4	4-8	8-15	15-25	5-10 litre. 600 mm tall.	8-15	15-25	40-70	80-100 litre. Approx. 650 mm tall, 350 x 400 mm in plan.	
Minimum volume increase (litre)		3	4	7		7	7	15		
Material allowed for container	Polypolyene or polyethylene	Polypolyene or polyethylene	Polypolyene or polyethylene	Polypolyene or polyethylene	Polypolyene or polyethylene	High density polyethylene	High density polyethylene	High density polyethylene	High density polyethylene	High density polyethylene
Handle required.	-	-	Yes	Yes	-	Yes	Yes	Yes	Yes	Yes
Allowable material for handle.	-	-	Polypolyene or polyethylene	Polypolyene or polyethylene	-	High density polyethylene	High density polyethylene	High density polyethylene	High density polyethylene	High density polyethylene
Wall Bracket required.	-	Yes	Yes	-	-	Yes	-	-	-	-

Nursing trolley Bracket req.	-	Yes	-	-	-	-	-	-	-	-	-	-
Wall/trolley Bracket material.	-	Mild / stainless Steels	Mild / stainless Steels	-	-	-	Mild / stainless Steel	-	-	-	-	-
Wall Bracket coating.	-	Powder coated/galvanise	Powder coated / galvanise	-	-	-	Powder coated / galvanise	-	-	-	-	-
Container colour.	Yellow	Yellow	Yellow	Yellow	Yellow	Yellow	Red	Red	Red	Red	Red	Red
Constituents <u>not</u> allowed in dye.	No heavy metals	No heavy metals	No heavy metals	No heavy metals	No heavy metals	No heavy metals	No heavy metals	No heavy metals	No heavy metals	No heavy metals	No heavy metals	No heavy metals
Printing Colour.	Red	Red	Red	Red	Red	Red	Red	Red	Red	Red	Red	Red
Constituents <u>not</u> allowed in ink / paint.	No heavy metals	No heavy metals	No heavy metals	No heavy metals	No heavy metals	No heavy metals	No heavy metals	No heavy metals	No heavy metals	No heavy metals	No heavy metals	No heavy metals

A1.3: Liners

Due to the different rates at which Waste is generated as well as the particular requirements for different liner applications, there is a need for a range of liners as well as Baskets and Freestanding Racks to be made available to Facilities, leaving it up to the Facilities to make a decision on the type of liners, Baskets and Freestanding Racks that would best meet their particular needs. It is further required that liners, Baskets and Freestanding Racks for both HCRW as well as HCGW be made available under this contract, although the Contractor would not under this contract have exclusive right for the supply of HCGW liners as well as Baskets and Freestanding Racks.

All plastic liners shall be packed and delivered in batches of 20 to allow for easy handling and internal distribution within Facilities.

The risk of infection and pollution caused by spillage is high, resulting in a need for liners to meet certain minimum standards in terms of user friendliness during handling and sealing as well as in terms of robustness.

The following requirements are to be met in the supply of plastic liners:

A1.3.1 Range of Red Waste Liners Required:

- a) 2.5- litres @ 40 micron thickness
- b) 12-litres @ 40 micron thickness;
- c) 30-litres @ 60 micron thickness;
- d) 50-litres @ 100 micron thickness;
- e) 85-litres @ 100 micron thickness;
- f) 90-litres @ 100 micron thickness;
- g) 100- litres @ 100 micron thickness;
- h) 125-litres @ 100 micron thickness.
- i) 142-litres @ 100 micron thickness
- k) 240- litres @100 micron thickness

A1.3.2 Material to be used in Manufacturing of Liners:

1. Liners are to be manufactured from Polyethylene (PE);
2. Liners shall not contain in excess of 15% recycled PE to ensure that strength and resistance to tearing is acceptable;
3. Dies must not contain heavy metals;
4. All Plastic Liner Baskets and Freestanding Racks are to be manufactured from mild steel and stainless steel respectively as indicated in Schedule of Rates and Quantities;
5. Plastic Liner Baskets and Freestanding Racks are to be powder coated or galvanised when manufactured from mild steel. No coating is required for stainless steel Baskets or Freestanding Racks.

The following type of ties for plastic liners shall be supplied:

- Standard Pure natural rubber bands, size 34 (3,0-mm x 100-mm) or size 35 (3,0-mm x 115-mm).

A1.3.3 Plastic Liner Design Requirements:

1. Liners for Waste must be red;
2. Liners may be semi-transparent;

3. All seams for liners of a thickness 40 micron must be single welded, whereas all liners with a thickness of more than 40 microns shall be double welded;
4. All liners are to be supplied with appropriate ties, with the number of ties exceeding the number of liners by 5%.

A1.3.4 Plastic Liner Markings:

No markings/printing will be required on any of the liners.

A1.3.5 Liner Mounting Baskets and Freestanding Racks:

Note: The plastic liner mounting Basket and Freestanding Rack designs as illustrated in Figures 3, 4 and 5 of this Annexure are typical of those used during the pilot studies. Although Bidders are invited to propose any alternative design, the aforesaid are indicative of the type of Baskets and Freestanding Racks that will be required.

1. Liners Type K1 and K2 should be compatible with wall mounting Baskets as well as Freestanding Racks, whilst liners type K1 should also be compatible with Baskets that can be hanged or clipped onto nursing trolleys to ensure safe positioning of liners during use.
2. Baskets and Freestanding Racks must as a minimum comply with the following specifications:
 - (a) Baskets and Freestanding Racks must be strong and robust and have a serviceable life of at least 5-years under normal working conditions. Any Baskets and Freestanding Racks that are not fully functional for the aforesaid service life are to be replaced by the contractor at any time during the contract period without any additional compensation;
 - (b) Brackets shall be grey or off-white coloured and shall be powder coated;
 - (c) Baskets and Freestanding Racks shall be smooth at all surfaces and free from cutting splinters, welding residues etc. that may cause abrasions to the hand or similar;
 - (d) Baskets and Freestanding Racks shall be easy to clean with no exposed areas being unreachable during usual cleaning operations.
 - (e) Freestanding Rack of stainless steel shall be equipped with 4 wheels, one of which must have a break. The overall height of the stainless-steel Freestanding Racks shall not exceed 800 mm, which is to include the height of the wheels.
 - (f) Facilities should have the choice between mild steel Freestanding Racks without wheels, or alternatively mild steel Freestanding Racks equipped with 4 wheels, of which one is to have a brake. The overall height of the Freestanding Racks shall in all instances not exceed the overall dimensions indicated in Figure 5.
 - (g) Due to the slow rate at which liners are filled in some of the smaller Facilities, bidders are during the design of baskets and freestanding racks to consider the possibility of providing some form of a closure mechanism that would reduce the emission of odours, provided that this would not increase the risk of contamination of baskets and racks to the extent that it would require frequent disinfection of fixed items. Where baskets and racks are offered that include some form of a closing mechanism at prices exceeding that of the open baskets or racks, such items are to be submitted as an alternative bid.
 - (h) Wall plates for all Disposable Container brackets and baskets shall be of uniform design with a standard screw pattern that would allow for the interchange of brackets or baskets without the need for any modification to the drilled holes or wall plugs.

Figure 1

WALL-MOUNTED BRACKET FOR 32L BIN

All dimensions in millimeters

- Note:** 1. Dimensional tolerances +/- 3 mm, except where otherwise indicated
 2. Bend radii (unless otherwise indicated): $15\text{ mm} < r > 5\text{ mm}$

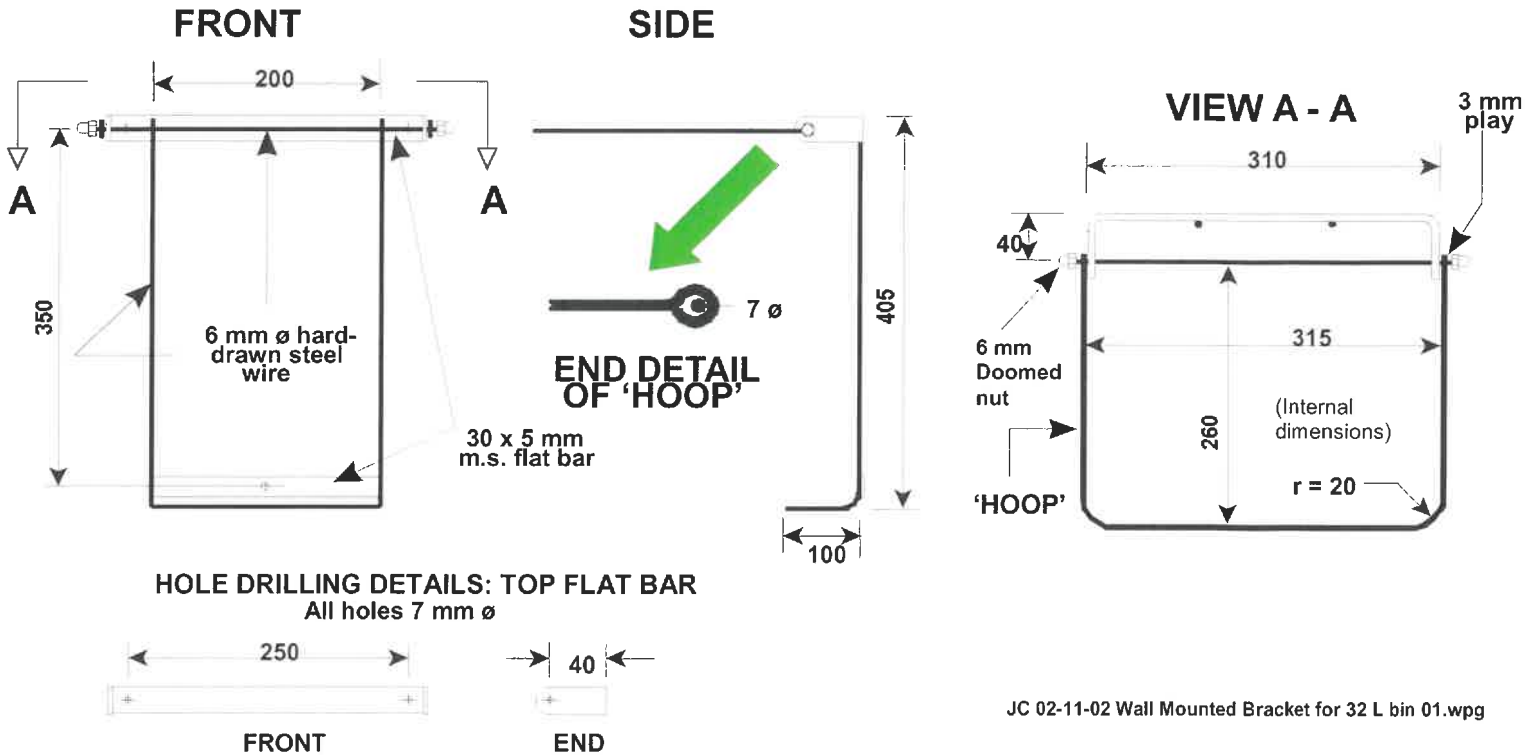
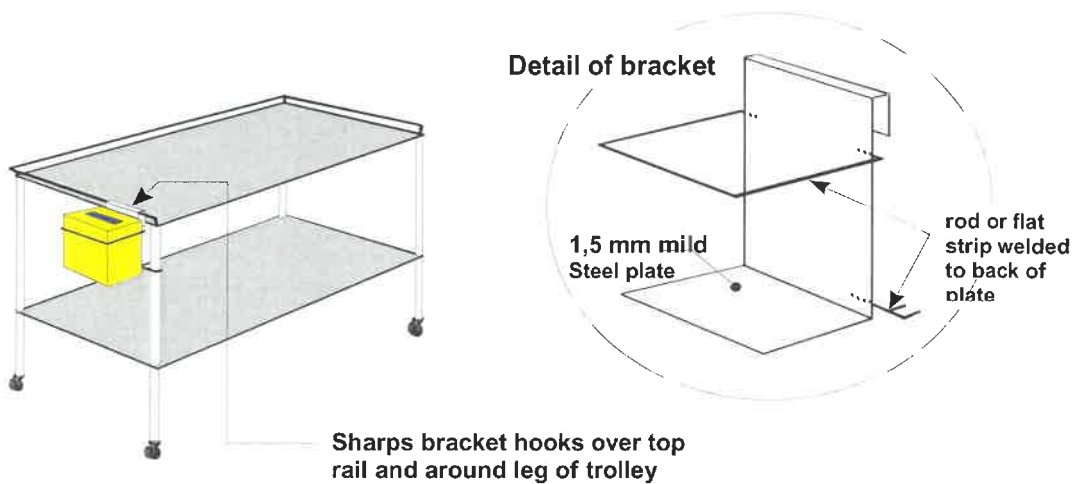

Figure 2

SHARPS CONTAINER BRACKET FOR NURSING TROLLEY



JC 02-11-01 Sharps Container Bracket for Nursing trolley.wpg

Figure 3

WALL-MOUNTED BASKET FOR HCRW BAG

All dimensions in millimetres

- Note:** 1. Dimensional tolerances ± 3 mm, except where otherwise indicated
 2. Bend radii (wire & flat bar) $5 \text{ mm} < r > 5 \text{ mm}$

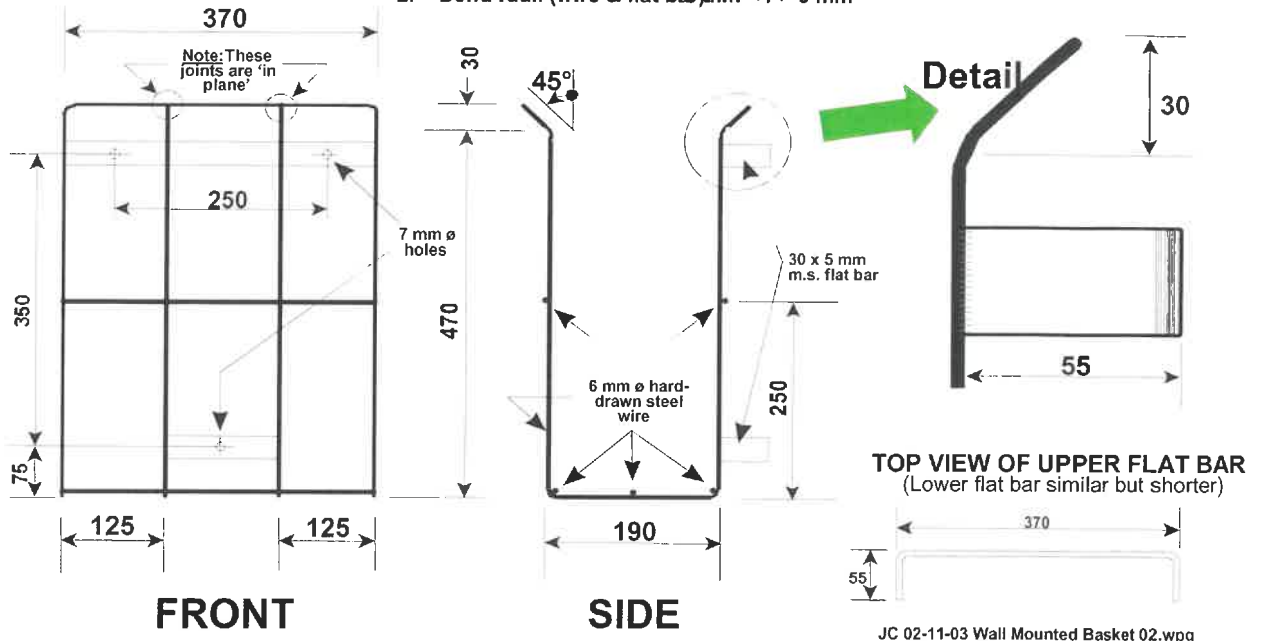

Figure 4

NURSING-TROLLEY BASKET FOR HCRW BAG

All dimensions in millimetres

Dimensional tolerances ± 3 mm, except where otherwise indicated

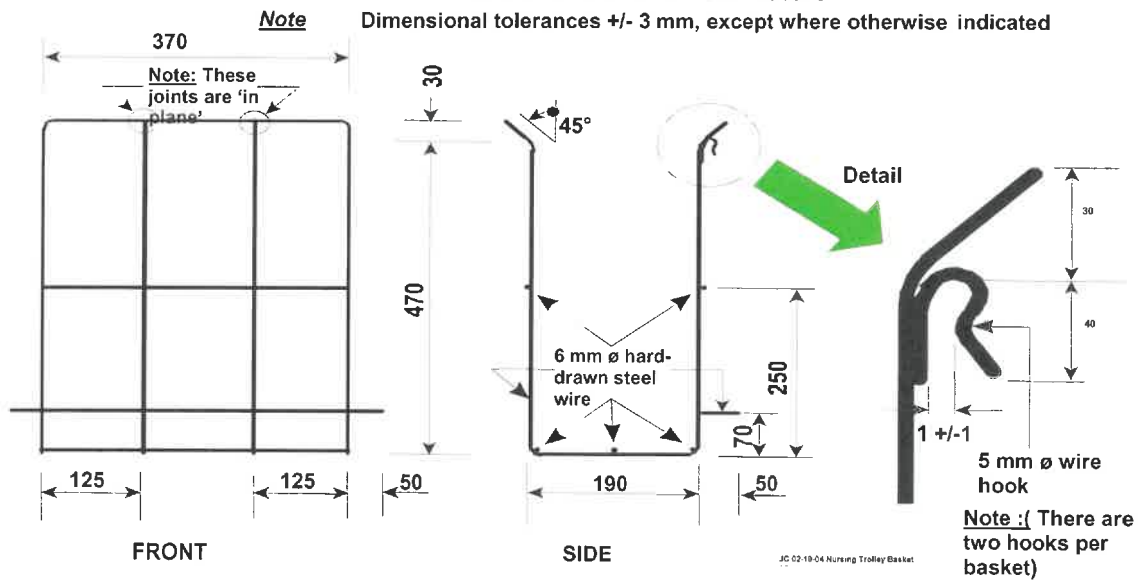
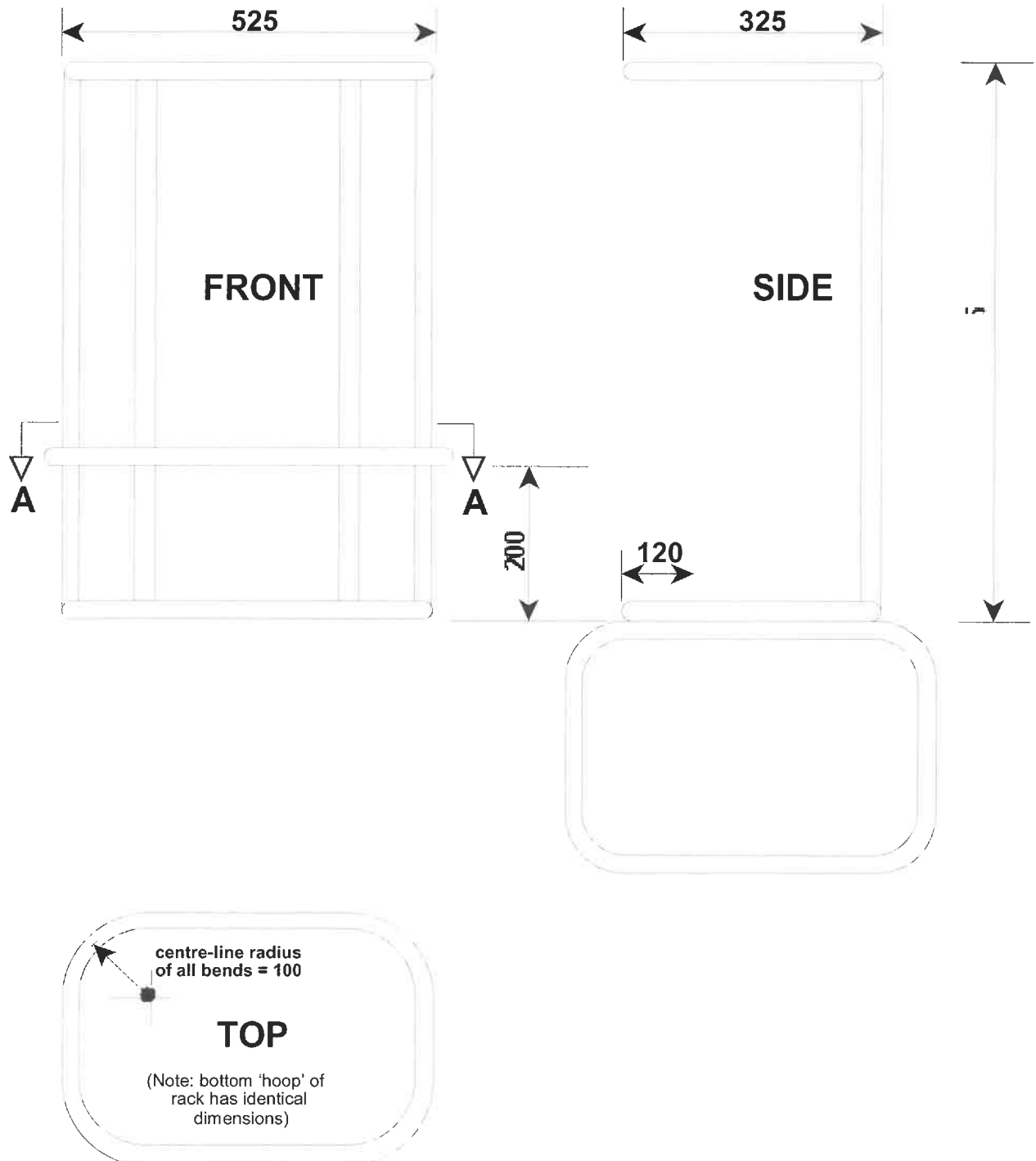

Figure 5

FREE-STANDING RACK FOR HCRW BAG



ANNEXURE 2: LIST OF HEALTH CARE FACILITIES

NORTH WEST PROVINCIAL HEALTHCARE FACILITIES		
PROVINCIAL & DISTRICT HOSPITALS & CHC'S		
DR RUTH SEGOMOTSI MOMPATI DISTRICT		
Provincial Hospital	District Hospitals	CHCs
Joe Morolong	Ganyesa	Ganyesa
		Tlakgameng
		Morokweng
		Bray
	Christiana	Bloemhof
	Schweizer-Reneke	Mamusa
	Taung	Manthe CHC
		Reivilo CHC
		Pudumoe CHC
		Huhudi
	Stella	
NGAKA MODIRA MOLEMA		
Provincial Hospital	District Hospitals	CHCs
Mahikeng / Bophelong		Lekoko
		Montshioa Stadt
		Ramatlabama
		Unit 9
	Itsoseng	
		Coligny
	General De La Rey	
	Zeerust	Borakalalo
		Moshana
		Tswelelopele
	Lehurutshe	Dinokana
		Atamelang
		Delareyville
		Ottosdal
		Sannieshof
	Makgobistad	
	Gelukspan	Ratlou
Mmabatho Medical Depot		

BOJANALA DISTRICT		
Job Shimankane Tabane		Kutlwanong
		Moretele
	Brits	Bapong
		Letlhabile
	Moses Kotane	Mogwase
		Mabeskraal
		Pella
	Ventersdorp Koster	
		Swartruggens
		Bafokeng
	Boitekong	
	Tlhabane	
DR KENNETH KAUNDA DISTRICT		
Provincial Hospital	District Hospital	CHCs
Klerksdorp /Tshepong		Botshabelo CHC
		Grace Mokgomo CHC
		Tigane
		Jouberton CHC
	Nic Bodenstein	Leeudoringstad CHC
		Tswelelang CHC
Potchefstroom		Boiki Tlhapi CHC
		Promosa CHC
		JB Marks CHC
		Ventersdorp CHC
Witransdorp (Specialised Hospital)		

DR RUTH SEGOMOTSI MOMPATI DISTRICT CLINICS				
TAUNG SUB-DISTRICT	KAGISANO MOLOPO SUB-DISTRICT	NALEDI SUB-DISTRICT	MAMUSA SUB-DISTRICT	LEKWA TEEMANE SUB-DISTRICT
Maphoitsile clinic	Tlapeng clinic	Colridge clinic	Amalia clinic	Coverdale clinic
Magogong clinic	Kgokgole clinic	Gateway clinic	Charon clinic	Boitumelong clinic
Mocweding clinic	Kgokgojane clinic		Ipelegeng clinic	Utlwanang clinic
Mokgareng clinic	Eckron		Glaudina clinic	Christiana Town clinic
Taung Gateway clinic	Austrey clinic		S-Reneke Town clinic	
Taung Station clinic	Phaposane clinic			
L/Majeakgoro clinic	Kudungwane clinic			
Mammutla clinic	Moswane clinic			
U/ Majeakgoro	Piet Plessis clinic			
Madipelesa clinic	Morokwaneng clinic			
Dryharts clinic	Tseoge clinic			
Matlapaneng clinic	Setabeng clinic			
Leshobo clinic	Bona-Bona clinic			
Maganeng clinic	Kokoana clinic			
Cokonyane clinic				
Buxton clinic				
Tshedimosetso Youth centre				
Mothanthanyaneng				
Picong clinic				
Tlapeng clinic				
Kokomeng clinic				
Khudutlou clinic				
Molelema clinic				
Tweelingspan				
Kgomotso				

NGAKA MODIRI MOLEMA DISTRICT CLINICS				
RATLOU SUB-DISTRICT	TSWAING SUB-DISTRICT	DITSOBOTLA SUB-DISTRICT	RAMOTSHERE MOILOA SUB-DISTRICT	MAFIKENG SUB-DISTRICT
Madibogo Old clinic	Agisanang clinic	Bakerville	Mokgola clinic	Dithakong
Madibogopan clinic	Vriesgewacht clinic	Bodibe New clinic	Lekubu clinic	Gelukspan Gateway
Setlagole clinic	Ganalaagte clinic	Boikhutso clinic	Groot Marico clinic	Lokaleng Clinic
Kraaipan clinic	Kunana clinic	Itsoseng clinic	Pachsdraai clinic	Lonely Park Clinic
Mareetsane clinic	Letsopa clinic	Itekeng clinic	Mmasebudile clinic	Mafikeng Gateway
Disaneng clinic	Mofufutso clinic	Calisonia clinic	Lehurutshe clinic	Magogwe Clinic
Tshidilamolomo clinic		LTX town clinic	Khunotswana clinic	Makouspan
Logageng clinic		Matile clinic	Gopane clinic	Masuthe 1
Masamane clinic		Holcim clinic	Motswedi clinic	Masuthe 2
Mabule clinic		Tlhabologang clinic	Lobatla clinic	Matlhonyane
Loporung clinic		Boitshoko clinic	Rietpan clinic	Matshepe
Maiyayane Health Post		Ga-motlatla clinic	Driefontein clinic	Maureen Roberts
Ramabese Health Post		Blydeville clinic	Lekgopung clinic	Miga
Moshawane Health Post		Blydeville II clinic	Supingstad clinic	Mocoseng
		Gateway clinic	Zeerust clinic	Modimola
		Bodibe Old clinic	Braklaagte	Mogosane
				Maruping
			Moshana	Montshioa Town
			Mosweu	Motlhabeng
				Ramatlabama
				Rapulana
				Setlopo
				Tlapeng
				Tsetse
				Tshunyane
				Weltevrede

BOJANALA DISTRICT CLINICS				
RUSTENBURG SUB-DISTRICT	KGETLENG SUB-DISTRICT	MOSES KOTANE SUB-DISTRICT	MADIBENG SUB-DISTRICT	MORETELE SUB-DISTRICT
Anna Legoale clinic	Reagile clinic	Bakubung clinic	Broederstroom clinic	Ga-Motla clinic
Bethani clinic	Koster gateway	Bapong clinic	Majakaneng clinic	Ratiepane clinic
Boitekong clinic	Borolelo clinic	Silverkrans clinic	Segwaelane clinic	Tladistad clinic
Chaneng clinic	Swartruggens TLC clinic	Obakeng clinic	Wonderkop clinic	Swartdam clinic
Classic House clinic		Ramokokastad	Modderspruit clinic	Kgomo-kgomo clinic
Hartebeesfontein clinic		Tweelaagte clinic	Sonop clinic	Kromkuil clinic
Kana clinic		Koffiekraal	Fafung clinic	(Mpho- ya-Batho)
Karlien Park clinic		Welgeval clinic	Jericho clinic	Mmakanya ne clinic
Luka clinic		Sandfontein clinic	Rabokala clinic	Mogogelo clinic
Marikana clinic		Seolong clinic	Maboloka clinic	Bosplaas clinic
Mfidikwe clinic		Uitkyk clinic	Oukasie Maternity	Leseding/ Dertig clinic
Monakato clinic		Wilverdient clinic	Ikhutseng clinic	Lefathheng clinic
Phatsima clinic		Moruleng clinic	Kgabalatsane clinic	Maubane clinic
Rankelenyane clinic		Modderkuil clinic	Mothutlung clinic	Mathibestad clinic
Rustenburg gateway		Linchwe clinic	Hoekfontein clinic	Thulwe clinic
Sunrise Park clinic		Kraalhoek	Moiletsoane clinic	Rugtesloot clinic
Thekwana clinic		IpopengMantserr clinic	Refentse clinic	Gahabedi
Tiaseng clinic		Neo clinic	Madidi clinic	Ngobi clinic
Freedom Park clinic		Lesetlhe clinic		Lebotloane clinic
		Legkraal		Dikebu/Sediane clinic
		Witrantjie clinic		Makapanstad
		Phalane clinic		Sesobe
		Lethakeng clinic		Rekopantse Clinic
		Motlhabec clinic		
		Baleema clinic		
		Boikanyo clinic		
		Molorwe clinic		
		Vlakplaas clinic		
		Koedoesrand clinic		
		Rietfontein clinic		

Madikwe clinic
Vrede clinic
Siga clinic
Brakuil clinic
Dwarsberg clinic
Mankaipaya clinic
Pitsedisulejang clinic
Khayakhulu clinic
David Katnagel clinic
Montsana clinic
Molatedi clinic
Rampampaspoort
Monono clinic
Elandskuil clinic
Tshireletso clinic
Sesobe

DR KENNETH KAUNDA DISTRICT CLINICS			
MAQUASSIE HILLS SUB-DISTRICT	MATLOSANA SUB-DISTRICT	VENTERSDORP SUB-DISTRICT	TLOKWE SUB-DISTRICT
Wolmaranstad clinic	Alabama	Gateway clinic	Top City clinic
Tswelelang clinic	DelekileKhoza	Mogopa clinic	Lesego clinic
Bophelo clinic	Empilisweni	Tsetse clinic	Boskop clinic
Makwassi clinic	Kanana	Welgevonden clinic	Potch clinic
SegametsiMogaetsho clinic	Khuma	Boikhotso clinic	Gateway clinic
Kgakala clinic	MajaraSephapo	Boikhutsong clinic	Mohadin clinic
	Marcus Zenzile	Goedgevonden clinic	Steve Tshwete clinic
	N Pretorius gateway	Kgotso	
	Orkney town		
	Park Street		
	Stilfontein		
	Tsholofelo		
	RB Nzima clinic		

ANNEXURE 3: SPECIFICATIONS FOR HEALTH CARE RISK WASTE COLLECTION TRAILER

CONTAINER RANGE

10 items in this album on 3 pages



Container style trailer
Viewed: 1 time.



Container style trailer
Viewed: 3 times.



Container style trailer



Container style trailer

The following specifications are for the manufacture and supply of a trailer to be used for the collection and transport of Health Care Risk Waste (HCRW):

- The trailer is to be used for the collection and transport of HCRW from rural clinics and hospitals and should therefore comply with all of the relevant road and dangerous goods transport legislation;
- The waste compartment is to be insulated with a 50-mm insulation material that is to be approved;
- The inside of the waste compartment is to be lined with seamless stainless-steel Grade 304 or similar approved, with rounded inside corners in the waste compartment;
- The outside material to be chromadek with a frost white finish;
- The waste compartment is to be equipped with a rear as well as a side door (left side), with the rear door being as close as possible to the full waste compartment width and full height for easy loading of waste containers. The side door (positioned right at the front of the waste compartment) should be as close as possible to the full compartment height, but with a 1-m width;
- The inside of the waste compartment should be water tight;
- All doors and openings in the waste compartment is to be provided with a 100-mm spillage containment stand-up that will prevent the accidental release of any liquids from the waste compartment;

- The trailer floor should be equipped with a drainage outlet, equipped with an outside tap and hose-pipe connection for the controlled release of liquids from the waste compartment during routine cleaning operations, and a drain plug without a tap in the front “nose-cone” section (see below);
- The required dangerous goods (Health Care Risk Waste) signage is to be provided on the trailer in accordance with SANS Code 10248:2004 Management of Health Care Waste;
- Additional tail, brake and hazard lights at the top end corners of the trailer is to be provided for better visibility of brake and hazard lights during collection rounds;
- A roof light with a switch at the rear door is to be provided inside the trailer to allow for after-hours HCRW collection in urban areas. Power supply combined with that of the red tail lights;
- A “Nose-Cone” consisting of the full trailer height triangular compartment, separated into 3 un-insulated compartments with a single door on the left side of trailer for storage of spill kit (bottom), as well as empty sharps and Specican containers (middle and top respectively).
- The front and rear doors of the trailers shall be equipped with a secure lock using a one-key padlock system;
- The single axle trailer chassis shall comply with the “Challenger” or “Venter” trailer specification, or similar approved.

The optional costs for promotional signage (1-m x 1-m) on the two sides of the trailer are to be provided.

Payload (kg)	700 (Material density around 200-250 kg/m ³)
Length (mm)	2400
Width (mm)	1300
Height (mm)	1350
Depth	-
Brakes Override	Required
Auto Reverse	Braking system required
Mass (kg)	-
GVM (kg)	-
Wheels	165x13
Loading Ramps	- N/A
Axle-beam (kg)	1250
Axle (ALKO)	-
Floor area (m ²)	N/A
Capacity (m ³)	3,40
Rails	N/A
Rear door	As close as possible to full trailer width by full trailer height.
Front door	As close as possible to 1-m wide by full trailer height on left side at front end of trailer.
Spare Wheel	Required.
Wheels & Tyres	Jockey wheel, 165 x 13” radial tyres, anti-theft wheel nuts (one per wheel) and anti-theft bar to be locked through wheels when parked.

ANNEXURE 4: NORTH WEST HEALTHCARE RISK WASTE COLLECTION POINTS

No.	NAME OF HEALTHCARE FACILITY	DISTRICT
1.	Lethabile Clinic	BOJANALA DISTRICT
2.	Kekanastad Clinic	
3.	Ramotse Clinic	
4.	Suurman Clinic	
5.	Refentse Clinic	
6.	Dilopye Clinic	
7.	Hartebeesfontein Clinic	
8.	Mogwase HC	
9.	Kanana Clinic	
10.	Boitekong Clinic	
11.	Bafokeng HC	
12.	Tlhabane HC	
13.	Classic House Clinic	
14.	Job Shimankana Tabane Provincial Hospital	
15.	Brits District Hospital	
16.	Moses Kotane District Hospital	
17.	Swaruggens District Hospital	
18.	Koster Hospital	
19.	Jouberton CHC	
20.	Empilisweni Clinic	
21.	Tsholofelo Clinic	
22.	Alabama Clinic	
23.	Grace Mokhomo Clinic	
24.	Kanana Clinic	
25.	Orkney Clinic	
26.	Gateway Clinic	
27.	Khuma Clinic	
28.	Park Street Clinic	
29.	Stilfontein Clinic	
30.	Marcus Zenzile Clinic	
31.	Botshabelo Clinic	
32.	Khuma Clinic	
33.	Boiki Tlhapi Clinic	
34.	Lesege Clinic	
35.	Promosa Clinic	
36.	Mohadin Clinic	
37.	Steve Tshwete Clinic	
38.	Potchefstroom Clinic	
39.	Potchefstroom Sub-district mobiles	
40.	Gateway Clinic	
41.	MajaraSephapo	
42.	Tshepong Gateway Clinic	
43.	Top City Clinic	
44.	Boskop Clinic	
45.	Thusanang Clinic	
46.	Matlosana EMRS Station	
47.	Potchefstroom EMRS Station	
48.	Ventersdorp EMRS Station	
49.	Maquassi EMRS Station	
50.	Blyvoor Clinic	
51.	Central Clinic	
52.	Tswelelang 1 Clinic	
53.	Tswelelang 2 Clinic	
54.	Segametsi Clinic	

55.	Makwasi Clinic	
56.	Leeudoringstad Clinic	
57.	Kgakala Clinic	
58.	Bophelo Clinic	
59.	Ventersdorp Gateway Clinic	
60.	Ventersdorp Clinic	
61.	Tigane Clinic	
62.	DelekileKhoza Clinic	
63.	JB Marks CHC	
64.	Witransd Specialised Hospital	
65.	Potchefstroom Hospital	
66.	Klerksdorp Tertiary Hospital	
67.	Tshepong Hospital	
68.	Nic Bodenstein District Hospital	
69.	Ventersdorp CHC	
70.	RB Nzima Clinic	
71.	Carlisonia	NGAKA MODIRI MOLEMA
72.	Itekeng	
73.	Ga-Motlatla	
74.	Itsoseng Clinic	
75.	Itsoseng CHC	
76.	Lichtenburg Town Clinic	
77.	Boikhutso	
78.	Boitshoko	
79.	Bodibe Old	
80.	Bodibe New	
81.	Matile	
82.	Tlhabologang	
83.	Bakerville	
84.	Coligny CHC	
85.	Blydeville New	
86.	Blydeville Old	
87.	AfriSam	
88.	Thusong Gateway Clinic	
89.	Makgobistad Clinic	
90.	Masamane Clinic	
91.	Tshidilamolomo	
92.	Logageng Clinic	
93.	Disaneng Clinic	
94.	Mabule Clinic	
95.	Mosweu Clinic	
96.	Loporung Clinic	
97.	Madibogo Clinic	
98.	Setlagole Clinic	
99.	Old Madibogo Clinic	
100.	Mareetsane Clinic	
101.	Kraaipan Clinic	
102.	Zeerust Clinic	
103.	Montshioa Town Clinic	
104.	Delareyville CHC	
105.	Ottosdal CHC	
106.	Sannieshof CHC	
107.	Atamelang CHC	
108.	Agisanang Clinic	
109.	Vrisgewacht Clinic	
110.	Ganalaagte Clinic	
111.	Kopela Clinic	

112.	Khunwana Clinic
113.	Letsopa Clinic
114.	Mofufutso Clinic
115.	Dinokana Health Centre
116.	Moshana
117.	Tswelelopele
118.	Dinokana Old
119.	Khunotswane
120.	Lehurutshe
121.	Gopane
122.	Motswedi
123.	Lobatla
124.	Mokgola
125.	Lekubu
126.	Masebudule
127.	Pachsdraai
128.	Rietpan
129.	Driefontein
130.	Supingstad
131.	Lekgopung
132.	Groot Marico
133.	Borakalalo
134.	Swartkopfontein
135.	Ntswelletsoku Health Post
136.	Mafikeng Gateway
137.	Lonely Park
138.	Maureen Roberts
139.	Mocoseng
140.	Montshioa Stadt CHC
141.	Motlhabeng
142.	Unit 9 CHC
143.	Lokaleng
144.	Mogosane
145.	Tlapeng
146.	Miga
147.	Tsetse
148.	Ramatlabama CHC
149.	Tshunyane
150.	Modimola
151.	Masutlhe I
152.	Masutlhe II
153.	Gelukspan Gateway
154.	Matlhonyane
155.	Matshepe
156.	Rapulana
157.	Makouspan
158.	Weltevreden
159.	Lekoko CHC
160.	Setlopo
161.	Magogwe
162.	Dithakong
163.	Maruping Clinic
164.	Zeerust District Hospital
165.	Lehurutshe District Hospital
166.	Mafikeng Provincial Hospital
167.	Bophelong Psychiatric Hospital
168.	General de la Rey District Hospital

169.	Itsoseng District Hospital	DR RUTH SEGOMOTSI MOMPATI
170.	Gelukspan District Hospital	
171.	Magogong clinic	
172.	Mocweding clinic	
173.	Mokgareng clinic	
174.	Taung Gateway clinic	
175.	Taung Station clinic	
176.	Lower Majeakgoro clinic	
177.	Mammutla clinic	
178.	Upper Majeakgoro	
179.	Madipelesa clinic	
180.	Dryharts clinic	
181.	Matlapaneng clinic	
182.	Leshobo clinic	
183.	Maganeng clinic	
184.	Cokonyane clinic	
185.	Buxton clinic	
186.	Mothanthanyaneng	
187.	Picong clinic	
188.	Tlapeng clinic	
189.	Kokomeng clinic	
190.	Khudutlou clinic	
191.	Molelema clinic	
192.	Tweelingspan (Matsheng)	
193.	Kgomotso	
194.	Christiana District Hospital	
195.	Coverdale clinic	
196.	Boitumelong clinic	
197.	Utlwanang clinic	
198.	Christiana Town clinic	
199.	Bloemhof Town Clinic	
200.	Mamusa CHC	
201.	Amalia clinic	
202.	Charon clinic	
203.	Ipelegeng clinic	
204.	Glaudina clinic	
205.	SchweizerReneke Town clinic	
206.	Joe Morolong Provincial Hospital	
207.	Colridge clinic	
208.	Gateway clinic	
209.	Ganyesa District Hospital	
210.	Tlapeng clinic	
211.	Kgokgole clinic	
212.	Kgokgojane clinic	
213.	Eckron	
214.	Austrey clinic	
215.	Phaposane clinic	
216.	Kudungwane clinic	
217.	Moswane clinic	
218.	Piet Plessis clinic	
219.	Morokwaneng clinic	
220.	Tseoge clinic	
221.	Setabeng clinic	
222.	Bona-Bona clinic	
223.	Kokoana clinic	

ANNEXURE 5: PRICE LISTS - COST OF 1KG OF HEALTHCARE RISK WASTE

A5.1 Preamble

- a. The Price Lists must be read in conjunction with the General Conditions of Contract, and Special Conditions of Contract, and Annexures and all other data included in these documents for the full intent and meaning of each clause or item.
- b. Bidders are advised to check the number of pages and, should any be found to be missing or in duplicate or the figures or writing indistinct or this Schedule of Rates and Quantities contains any obvious errors, the Bidder must inform the Department at once and have it rectified. No liability whatsoever will be admitted in respect of errors due to the foregoing.

Should there be any doubt or obscurity as to the meaning of any particular item, the Bidder must obtain an explanation of it, in writing, from the Department or its representative. No claims for extras arising from any such doubt or obscurity will be admitted after submission of the Bid.

- c. The Bidder is advised to read this document in conjunction with the document containing a form for completion by all bidders: Item 8, pages 19 to 22.

No claim whatsoever will be allowed in respect of errors in pricing due to abbreviation of the description of items which are fully described when read in conjunction with the relevant specification.

- d. Bidders are referred to these Specifications in which further information in respect of certain scheduled items can be obtained. This is meant as an aid to Bidders but does not imply that the Specifications or clauses referred to are the only sources of information in respect of these items and further information and explanations may be found elsewhere in the Bid documents and in the Annexures.
- e. **All unit prices shall be quoted gross and be Inclusive of Value Added Tax (VAT).**
- f. All unit prices must be entered in the Schedule in BLACK INK.
- g. The unit prices to be inserted in the Price Lists are to be the fully inclusive value of the work described under the several items, including all costs and expenses which may be required in and for the execution of the work described, together with all general risks, liabilities and obligations set forth or implied in the documents on which the bid is based.
- h. **A sum or unit price is to be entered against each item in the Price Lists, whether quantities are stated or not.**
- i. All prices shall be quoted in the currency of the Republic of South Africa and will be subject to adjustment as specified in the Specification.

A5.2 Cost of 1kg of Healthcare Risk Waste:

State an all-inclusive cost measured in kg (excluding the container mass) of sharps waste collected in disposable containers for the collection, transportation, treatment and disposal of waste, irrespective of the type of disposable container used (excluding pharmaceutical waste and containers):

Rands	Cents

(Including VAT)

State an all-inclusive cost measured in kg (excluding the container mass) of pathological waste (in Specicans) collected in disposable containers for the collection, transportation, treatment and disposal of waste, irrespective of the type of disposable container used (excluding pharmaceutical waste and containers):

Rands	Cents

(Including VAT)

State an all-inclusive cost measured in kg (excluding the container mass) of infectious waste (in cartons / boxes) collected in disposable containers for the collection, transportation, treatment and disposal of waste, irrespective of the type of disposable container used (excluding pharmaceutical waste and containers):

Rands	Cents

(Including VAT)

State an all-inclusive cost measured in kg (excluding the container mass) of pharmaceutical waste collected in disposable containers for the collection, transportation, treatment and disposal of pharmaceutical waste, irrespective of the type of disposable container used:

Rands	Cents

(Including VAT)

Note: Bidders are requested to quote separately for each district.

**ANNEXURE 6: PRICE LISTS FOR SUPPLY OF DISPOSABLE CONTAINERS
(RECURRING ITEMS)**

NB: BIDDERS MUST BID SEPARATELY PER DISTRICT, THAT IS FOR (A6.1) DR RUTH SEGOMOTSI MOMPATI DISTRICT, (A6.2) DR KENNETH KAUNDA DISTRICT, (A6.3) NGAKA MODIRI MOLEMA DISTRICT AND (A6.4) BOJANALA DISTRICT

NAME OF BIDDING

COMPANY:.....

A6.1 DR RUTH SEGOMOTSI MOMPATI DISTRICT

DESCRIPTION	VOLUME	UNIT PRICE
Disposable items		
1. Sharps Containers	500ml	
	1 Litres	
	1.5 Litres	
	2.5 Litres	
	5 Litres	
	7.6 Litres	
	10 Litres	
	15 Litres	
	20 Litres	
	25 Litres	
NB: Quote for all the various volumes. Do not insert any other volumes.		
2. Tall slim sharps	5 Litres	
	10 Litres	
NB: Quote for all the various volumes. Do not insert any other volumes.		
3. Mono-can (Trochar)	600mm x 75mm	
NB: Do not insert any other volumes.		
4. Specican Containers (Rectangular)	2.5 Litres	
	5 Litres	
	10 Litres	
	15 Litres	
	20 Litres	

	25 Litres	
	40 Litres	
	70 Litres	
	80 Litres	
	100 Litres	
NB: Quote for all the various volumes. Do not insert any other volumes.		
5. Specican Containers (Round Mould)	50 Litres	
	100 Litres	
	142 Litres	
NB: Quote for all the various volumes. Do not insert any other volumes.		
6. Cartons / Boxes	30 Litres	
	50 Litres	
	140 Litres	
	142 Litres	
7. Reusable Cartons/boxes		
7.1 Rental price including cleaning and disinfection	90 Litres	
	125 Litres	
7.2 Purchase Price	90 Litres	
	125 Litres	
7.3 Disinfection Prices	90 Litres	
	125 Litres	
NB: Quote for all the various volumes. Do not insert any other volumes and do not combine the carton with the red plastic liner stating the unit price.		
8. Red Plastic Liners	2.5 Litre / 40mic	
	12 Litre / 40mic	
	30 Litre / 60mic	
	50 Litre / 100mic	
	85 Litre / 100mic	
	90 Litre / 100mic	
	100 Litre / 100mic	
	142 Litre / 100mic	
	240 Litre /100mic	
NB: Quote for all the various volumes. Do not insert any other volumes.		

9. Pharmaceutical containers	5 Litres	
	10 Litres	
	20 Litres	
	25 Litres	
	50 Litres	
	100 Litres	
NB: Quote for all the various volumes. Do not insert any other volumes.		
10. Sealing tapes/ bio-tapes		
5m one side adhesive tape bearing hazardous substance signage & company name		
11. Mattress plastic		
Big disposable mattress Plastics		
12. Bubble wrap		
TOTAL PRICE		

NAME OF BIDDING

COMPANY:.....

A6.2 DR KENNETH KAUNDA DISTRICT

DESCRIPTION	VOLUME	UNIT PRICE
Disposable items		
1. Sharps Containers	500ml	
	1 Litres	
	1.5 Litres	
	2.5 Litres	
	5 Litres	
	7.6 Litres	
	10 Litres	
	15 Litres	
	20 Litres	
	25 Litres	
NB: Quote for all the various volumes. Do not insert any other volumes.		
2. Tall slim sharps	5 Litres	
	10 Litres	
NB: Quote for all the various volumes. Do not insert any other volumes.		
3. Mono-can (Trochar)	600mm x 75mm	
NB: Do not insert any other volumes.		
4. Specican Containers (Rectangular)	2.5 Litres	
	5 Litres	
	10 Litres	
	15 Litres	
	20 Litres	
	25 Litres	
	40 Litres	
	70 Litres	

	80 Litres	
	100 Litres	
NB: Quote for all the various volumes. Do not insert any other volumes.		
5. Specican Containers (Round Mould)	50 Litres	
	100 Litres	
	142 Litres	
NB: Quote for all the various volumes. Do not insert any other volumes.		
6. Cartons / Boxes	30 Litres	
	50 Litres	
	140 Litres	
	142 Litres	
7. Reusable Cartons/boxes		
7.1 Rental price including cleaning and disinfection	90 Litres	
	125 Litres	
7.2 Purchase Price	90 Litres	
	125 Litres	
7.3 Disinfection Price	90 Litres	
	125 Litres	
NB: Quote for all the various volumes. Do not insert any other volumes and do not combine the carton with the red plastic liner stating the unit price.		
8. Red Plastic Liners	2.5 Litre/40mic	
	12 Litre / 40mic	
	30 Litre / 60mic	
	50 Litre / 100mic	
	85 Litre / 100mic	
	90 Litre / 100mic	
	100 Litre / 100mic	
	142 Litre / 100mic	
	240Litre/100mic	
NB: Quote for all the various volumes. Do not insert any other volumes.		
9. Pharmaceutical containers	5 Litres	

	10 Litres	
	20 Litres	
	25 Litres	
	50 Litres	
	100 Litres	
NB: Quote for all the various volumes. Do not insert any other volumes.		
10. Sealing tapes/ bio-tapes		
5m one side adhesive tape bearing hazardous substance signage & company name		
11. Mattress plastic		
Big disposable mattress plastics		
12. Bubble wrap		
TOTAL PRICE		

NAME OF BIDDING

COMPANY:.....

A6.3 NGAKA MODIRI MOLEMA DISTRICT

DESCRIPTION	VOLUME	UNIT PRICE
Disposable items		
1. Sharps Containers	500ml	
	1 Litres	
	1.5 Litres	
	2.5 Litres	
	5 Litres	
	7.6 Litres	
	10 Litres	
	15 Litres	
	20 Litres	
	25 Litres	
NB: Quote for all the various volumes. Do not insert any other volumes.		
2. Tall slim sharps	5 Litres	
	10 Litres	
NB: Quote for all the various volumes. Do not insert any other volumes.		
3. Mono-can (Trochar)	600mm x 75mm	
NB: Do not insert any other volumes.		
4. Specican Containers (Rectangular)	2.5 Litres	
	5 Litres	
	10 Litres	
	15 Litres	
	20 Litres	
	25 Litres	
	40 Litres	

	70 Litres	
	80 Litres	
	100 Litres	
NB: Quote for all the various volumes. Do not insert any other volumes.		
5. Specican Containers (Round Mould)	50 Litres	
	100 Litres	
	142 Litres	
NB: Quote for all the various volumes. Do not insert any other volumes.		
6. Cartons / Boxes	30 Litres	
	50 Litres	
	140 Litres	
	142 Litres	
7. Reusable Cartons/boxes		
7.1 Rental price including cleaning and disinfection	90 Litres	
	125 Litres	
7.2 Purchase Price	90 Litres	
	125 Litres	
7.3 Disinfection Price	90 Litres	
	125 Litres	
NB: Quote for all the various volumes. Do not insert any other volumes and do not combine the carton with the red plastic liner stating the unit price.		
8. Red Plastic Liners	2.5 Litre/40mic	
	12 Litre / 40mic	
	30 Litre / 60mic	
	50 Litre / 100mic	
	85 Litre / 100mic	
	90 Litre / 100mic	
	100 Litre / 100mic	
	142 Litre / 100mic	
	240 Litre/100mic	
NB: Quote for all the various volumes. Do not insert any other volumes.		
9. Pharmaceutical containers	5 Litres	
	10 Litres	

	20 Litres	
	25 Litres	
	50 Litres	
	100 Litres	
NB: Quote for all the various volumes. Do not insert any other volumes.		
10. Sealing tapes/ bio-tapes		
5m one side adhesive tape bearing hazardous substance signage & company name		
11. Mattress plastic		
Big disposable mattress plastics		
12. Bubble wrap		
TOTAL PRICE		

NAME OF BIDDING

COMPANY:.....

A6.4 BOJANALA DISTRICT

DESCRIPTION	VOLUME	UNIT PRICE
Disposable items		
1. Sharps Containers	500ml	
	1 Litres	
	1.5 Litres	
	2.5 Litres	
	5 Litres	
	7.6 Litres	
	10 Litres	
	15 Litres	
	20 Litres	
	25 Litres	
NB: Quote for all the various volumes. Do not insert any other volumes.		
2. Tall slim sharps	5 Litres	
	10 Litres	
NB: Quote for all the various volumes. Do not insert any other volumes.		
3. Mono-can (Trochar)	600mm x 75mm	
NB: Do not insert any other volumes.		
4. Specican Containers (Rectangular)	2.5 Litres	
	5 Litres	
	10 Litres	
	15 Litres	
	20 Litres	
	25 Litres	
	40 Litres	

	70 Litres	
	80 Litres	
	100 Litres	
NB: Quote for all the various volumes. Do not insert any other volumes.		
5. Specican Containers (Round Mould)	50 Litres	
	100 Litres	
	142 Litres	
NB: Quote for all the various volumes. Do not insert any other volumes.		
6. Cartons / Boxes	30 Litres	
	50 Litres	
	140 Litres	
	142 Litres	
7. Reusable Cartons/boxes		
7.1 Rental price including cleaning and disinfection	90 Litres	
	125 Litres	
7.2 Purchase Price	90 Litres	
	125 Litres	
7.3 Disinfection Price	90 Litres	
	125 Litres	
NB: Quote for all the various volumes. Do not insert any other volumes and do not combine the carton with the red plastic liner stating the unit price.		
8. Red Plastic Liners	2.5 Litre / 40mic	
	12/ Litre / 40mic	
	30 Litre / 60mic	
	50 Litre / 100mic	
	85 Litre / 100mic	
	90 Litre / 100mic	
	100 Litre / 100mic	
	142 Litre / 100mic	
	240 Litre / 100mic	
NB: Quote for all the various volumes. Do not insert any other volumes.		
9. Pharmaceutical containers	5 Litres	
	10 Litres	

	20 Litres	
	25 Litres	
	50 Litres	
	100 Litres	
NB: Quote for all the various volumes. Do not insert any other volumes.		
10. Sealing tapes/ bio-tapes		
5m one side adhesive tape bearing hazardous substance signage & company name		
11. Mattress plastic		
Big disposable mattress plastics		
12 Bubble wrap		
TOTAL PRICE		

ANNEXURE 7: PRICE LISTS FOR SUPPLY OF DURABLE ITEMS (ONCE-OFF ITEMS)

NB: BIDDERS MUST BID SEPARATELY, THAT IS FOR (A7.1) DR RUTH SEGOMOTSI MOMPATI DISTRICT, (A7.2) DR KENNETH KAUNDA DISTRICT, (A7.3) NGAKA MODIRI MOLEMA DISTRICT AND (A7.4) BOJANALA DISTRICT

NAME OF BIDDING

COMPANY:.....

A7.1 DR RUTH SEGOMOTSI MOMPATI DISTRICT

DESCRIPTION	UNIT PRICE
1. Brackets	
2. Baskets	
3. Freestanding Racks	
TOTAL PRICE	

NAME OF BIDDING COMPANY:.....

A7.2 DR KENNETH KAUNDA DISTRICT

DESCRIPTION	UNIT PRICE
1. Brackets	
2. Baskets	
3. Freestanding Racks	
TOTAL PRICE	

NAME OF BIDDING

COMPANY:.....

A7.3 NGAKA MODIRI MOLEMA DISTRICT

DESCRIPTION	UNIT PRICE
1. Brackets	
2. Baskets	
3. Freestanding Racks	
TOTAL PRICE	

NAME OF BIDDING

COMPANY:.....

A7.4 BOJANALA DISTRICT

DESCRIPTION	UNIT PRICE
1. Brackets	
2. Baskets	
3. Freestanding Racks	
TOTAL PRICE	

PART A INVITATION TO BID

YOU ARE HEREBY INVITED TO BID FOR REQUIREMENTS OF THE (NAME OF DEPARTMENT/ PUBLIC ENTITY)					
BID NUMBER:	NWDOH 12/2024	CLOSING DATE:	17 APRIL 2024	CLOSING TIME:	11:00
DESCRIPTION	SUPPLY OF HEALTHCARE WASTE RECEPTACLES AND THE REMOVAL, TREATMENT AND FINAL DISPOSAL OF HEALTH CARE RISK WASTE FROM HEALTH CARE FACILITIES UNDER THE JURISDICTION OF THE NORTH WEST PROVINCE FOR A PERIOD OF FOUR (04) YEARS				
BID RESPONSE DOCUMENTS MAY BE DEPOSITED IN THE BID BOX SITUATED AT (STREET ADDRESS)					
DEPARTMENT OF HEALTH NORTH WEST, GROUND FLOOR, NEW OFFICE PARK BUILDING, 3801 CORNER FIRST STREET AND SEKAME, MMABATHO (BEHIND THE CROSSING MALL)					
BIDDING PROCEDURE ENQUIRIES MAY BE DIRECTED TO			TECHNICAL ENQUIRIES MAY BE DIRECTED TO:		
CONTACT PERSON	MS T MATSHOBA		CONTACT PERSON	Mr Gift Mongologa	
TELEPHONE NUMBER	018 391 4043		TELEPHONE NUMBER	067 416 9049/ 082 548 3410	
FACSIMILE NUMBER	N/A		FACSIMILE NUMBER	N/A	
E-MAIL ADDRESS	tmatshob@nwpg.gov.za		E-MAIL ADDRESS	gmongologa@nwpg.gov.za	
SUPPLIER INFORMATION					
NAME OF BIDDER					
POSTAL ADDRESS					
STREET ADDRESS					
TELEPHONE NUMBER	CODE		NUMBER		
CELLPHONE NUMBER					
FACSIMILE NUMBER	CODE		NUMBER		
E-MAIL ADDRESS					
VAT REGISTRATION NUMBER					
SUPPLIER COMPLIANCE STATUS	TAX COMPLIANCE SYSTEM PIN:		OR	CENTRAL SUPPLIER DATABASE No:	MAAA
B-BBEE STATUS LEVEL VERIFICATION CERTIFICATE	TICK APPLICABLE BOX] <input type="checkbox"/> Yes <input type="checkbox"/> No		B-BBEE STATUS LEVEL SWORN AFFIDAVIT	[TICK APPLICABLE BOX] <input type="checkbox"/> Yes <input type="checkbox"/> No	
[A B-BBEE STATUS LEVEL VERIFICATION CERTIFICATE/ SWORN AFFIDAVIT (FOR EMES & QSEs) MUST BE SUBMITTED IN ORDER TO QUALIFY FOR PREFERENCE POINTS FOR B-BBEE]					
ARE YOU THE ACCREDITED REPRESENTATIVE IN SOUTH AFRICA FOR THE GOODS /SERVICES /WORKS OFFERED?	<input type="checkbox"/> Yes <input type="checkbox"/> No [IF YES ENCLOSE PROOF]		ARE YOU A FOREIGN BASED SUPPLIER FOR THE GOODS /SERVICES /WORKS OFFERED?	<input type="checkbox"/> Yes <input type="checkbox"/> No [IF YES, ANSWER THE QUESTIONNAIRE BELOW]	
QUESTIONNAIRE TO BIDDING FOREIGN SUPPLIERS					
IS THE ENTITY A RESIDENT OF THE REPUBLIC OF SOUTH AFRICA (RSA)?			<input type="checkbox"/> YES <input type="checkbox"/> NO		
DOES THE ENTITY HAVE A BRANCH IN THE RSA?			<input type="checkbox"/> YES <input type="checkbox"/> NO		
DOES THE ENTITY HAVE A PERMANENT ESTABLISHMENT IN THE RSA?			<input type="checkbox"/> YES <input type="checkbox"/> NO		
DOES THE ENTITY HAVE ANY SOURCE OF INCOME IN THE RSA?			<input type="checkbox"/> YES <input type="checkbox"/> NO		
IS THE ENTITY LIABLE IN THE RSA FOR ANY FORM OF TAXATION?			<input type="checkbox"/> YES <input type="checkbox"/> NO		
IF THE ANSWER IS "NO" TO ALL OF THE ABOVE, THEN IT IS NOT A REQUIREMENT TO REGISTER FOR A TAX COMPLIANCE STATUS SYSTEM PIN CODE FROM THE SOUTH AFRICAN REVENUE SERVICE (SARS) AND IF NOT REGISTER AS PER 2.3 BELOW.					

**PART B
TERMS AND CONDITIONS FOR BIDDING**

1. BID SUBMISSION:
1.1. BIDS MUST BE DELIVERED BY THE STIPULATED TIME TO THE CORRECT ADDRESS. LATE BIDS WILL NOT BE ACCEPTED FOR CONSIDERATION.
1.2. ALL BIDS MUST BE SUBMITTED ON THE OFFICIAL FORMS PROVIDED-(NOT TO BE RE-TYPED) OR IN THE MANNER PRESCRIBED IN THE BID DOCUMENT.
1.3. THIS BID IS SUBJECT TO THE PREFERENTIAL PROCUREMENT POLICY FRAMEWORK ACT, 2000 AND THE PREFERENTIAL PROCUREMENT REGULATIONS, THE GENERAL CONDITIONS OF CONTRACT (GCC) AND, IF APPLICABLE, ANY OTHER SPECIAL CONDITIONS OF CONTRACT.
1.4. THE SUCCESSFUL BIDDER WILL BE REQUIRED TO FILL IN AND SIGN A WRITTEN CONTRACT FORM (SBD7).
2. TAX COMPLIANCE REQUIREMENTS
2.1 BIDDERS MUST ENSURE COMPLIANCE WITH THEIR TAX OBLIGATIONS.
2.2 BIDDERS ARE REQUIRED TO SUBMIT THEIR UNIQUE PERSONAL IDENTIFICATION NUMBER (PIN) ISSUED BY SARS TO ENABLE THE ORGAN OF STATE TO VERIFY THE TAXPAYER'S PROFILE AND TAX STATUS.
2.3 APPLICATION FOR TAX COMPLIANCE STATUS (TCS) PIN MAY BE MADE VIA E-FILING THROUGH THE SARS WEBSITE WWW.SARS.GOV.ZA.
2.4 BIDDERS MAY ALSO SUBMIT A PRINTED TCS CERTIFICATE TOGETHER WITH THE BID.
2.5 IN BIDS WHERE CONSORTIA / JOINT VENTURES / SUB-CONTRACTORS ARE INVOLVED, EACH PARTY MUST SUBMIT A SEPARATE TCS CERTIFICATE / PIN / CSD NUMBER.
2.6 WHERE NO TCS PIN IS AVAILABLE BUT THE BIDDER IS REGISTERED ON THE CENTRAL SUPPLIER DATABASE (CSD), A CSD NUMBER MUST BE PROVIDED.
2.7 NO BIDS WILL BE CONSIDERED FROM PERSONS IN THE SERVICE OF THE STATE, COMPANIES WITH DIRECTORS WHO ARE PERSONS IN THE SERVICE OF THE STATE, OR CLOSE CORPORATIONS WITH MEMBERS PERSONS IN THE SERVICE OF THE STATE."

NB: FAILURE TO PROVIDE / OR COMPLY WITH ANY OF THE ABOVE PARTICULARS MAY RENDER THE BID INVALID.

SIGNATURE OF BIDDER:

CAPACITY UNDER WHICH THIS BID IS SIGNED:
(Proof of authority must be submitted e.g. company resolution)

DATE:

BIDDER'S DISCLOSURE

1. PURPOSE OF THE FORM

Any person (natural or juristic) may make an offer or offers in terms of this invitation to bid. In line with the principles of transparency, accountability, impartiality, and ethics as enshrined in the Constitution of the Republic of South Africa and further expressed in various pieces of legislation, it is required for the bidder to make this declaration in respect of the details required hereunder.

Where a person/s are listed in the Register for Tender Defaulters and / or the List of Restricted Suppliers, that person will automatically be disqualified from the bid process.

2. Bidder's declaration

2.1 Is the bidder, or any of its directors / trustees / shareholders / members / partners or any person having a controlling interest¹ in the enterprise, employed by the state? **YES/NO**

2.1.1 If so, furnish particulars of the names, individual identity numbers, and, if applicable, state employee numbers of sole proprietor/ directors / trustees / shareholders / members/ partners or any person having a controlling interest in the enterprise, in table below.

Full Name	Identity Number	Name of State institution

2.2 Do you, or any person connected with the bidder, have a relationship

¹ the power, by one person or a group of persons holding the majority of the equity of an enterprise, alternatively, the person/s having the deciding vote or power to influence or to direct the course and decisions of the enterprise.

with any person who is employed by the procuring institution? **YES/NO**

2.2.1 If so, furnish particulars:

.....
.....

2.3 Does the bidder or any of its directors / trustees / shareholders / members / partners or any person having a controlling interest in the enterprise have any interest in any other related enterprise whether or not they are bidding for this contract? **YES/NO**

2.3.1 If so, furnish particulars:

.....
.....

3 DECLARATION

I, _____ the _____ undersigned, (name)..... in submitting the accompanying bid, do hereby make the following statements that I certify to be true and complete in every respect:

- 3.1 I have read and I understand the contents of this disclosure;
- 3.2 I understand that the accompanying bid will be disqualified if this disclosure is found not to be true and complete in every respect;
- 3.3 The bidder has arrived at the accompanying bid independently from, and without consultation, communication, agreement or arrangement with any competitor. However, communication between partners in a joint venture or consortium² will not be construed as collusive bidding.
- 3.4 In addition, there have been no consultations, communications, agreements or arrangements with any competitor regarding the quality, quantity, specifications, prices, including methods, factors or formulas used to calculate prices, market allocation, the intention or decision to submit or not to submit the bid, bidding with the intention not to win the bid and conditions or delivery particulars of the products or services to which this bid invitation relates.
- 3.4 The terms of the accompanying bid have not been, and will not be, disclosed by the bidder, directly or indirectly, to any competitor, prior to the date and time of the official bid opening or of the awarding of the contract.
- 3.5 There have been no consultations, communications, agreements or arrangements made by the bidder with any official of the procuring

² Joint venture or Consortium means an association of persons for the purpose of combining their expertise, property, capital, efforts, skill and knowledge in an activity for the execution of a contract.

institution in relation to this procurement process prior to and during the bidding process except to provide clarification on the bid submitted where so required by the institution; and the bidder was not involved in the drafting of the specifications or terms of reference for this bid.

- 3.6 I am aware that, in addition and without prejudice to any other remedy provided to combat any restrictive practices related to bids and contracts, bids that are suspicious will be reported to the Competition Commission for investigation and possible imposition of administrative penalties in terms of section 59 of the Competition Act No 89 of 1998 and or may be reported to the National Prosecuting Authority (NPA) for criminal investigation and or may be restricted from conducting business with the public sector for a period not exceeding ten (10) years in terms of the Prevention and Combating of Corrupt Activities Act No 12 of 2004 or any other applicable legislation.

I CERTIFY THAT THE INFORMATION FURNISHED IN PARAGRAPHS 1; 2 and 3 ABOVE IS CORRECT.

I ACCEPT THAT THE STATE MAY REJECT THE BID OR ACT AGAINST ME IN TERMS OF PARAGRAPH 6 OF PFMA SCM INSTRUCTION 03 OF 2021/22 ON PREVENTING AND COMBATING ABUSE IN THE SUPPLY CHAIN MANAGEMENT SYSTEM SHOULD THIS DECLARATION PROVE TO BE FALSE.

.....
Signature	Date
.....
Position	Name of bidder

PREFERENCE POINTS CLAIM FORM IN TERMS OF THE PREFERENTIAL PROCUREMENT REGULATIONS 2022

This preference form must form part of all tenders invited. It contains general information and serves as a claim form for preference points for specific goals.

NB: BEFORE COMPLETING THIS FORM, TENDERERS MUST STUDY THE GENERAL CONDITIONS, DEFINITIONS AND DIRECTIVES APPLICABLE IN RESPECT OF THE TENDER AND PREFERENTIAL PROCUREMENT REGULATIONS, 2022

1. GENERAL CONDITIONS

1.1 The following preference point systems are applicable to invitations to tender:

- the 80/20 system for requirements with a Rand value of up to R50 000 000 (all applicable taxes included); and
- the 90/10 system for requirements with a Rand value above R50 000 000 (all applicable taxes included).

1.2 To be completed by the organ of state

(delete whichever is not applicable for this tender).

- a) The applicable preference point system for this tender is the **90/10** preference point system.
- b) The applicable preference point system for this tender is the **80/20** preference point system.
- c) Either the **90/10 or 80/20 preference point system** will be applicable in this tender. The lowest/ highest acceptable tender will be used to determine the accurate system once tenders are received.

1.3 Points for this tender (even in the case of a tender for income-generating contracts) shall be awarded for:

- (a) Price; and
- (b) Specific Goals.

1.4 To be completed by the organ of state:

The maximum points for this tender are allocated as follows:

	POINTS
PRICE	90
SPECIFIC GOALS	10
Total points for Price and SPECIFIC GOALS	100

- 1.5 Failure on the part of a tenderer to submit proof or documentation required in terms of this tender to claim points for specific goals with the tender, will be interpreted to mean that preference points for specific goals are not claimed.
- 1.6 The organ of state reserves the right to require of a tenderer, either before a tender is adjudicated or at any time subsequently, to substantiate any claim in regard to preferences, in any manner required by the organ of state.

2. DEFINITIONS

- (a) “**tender**” means a written offer in the form determined by an organ of state in response to an invitation to provide goods or services through price quotations, competitive tendering process or any other method envisaged in legislation;
- (b) “**price**” means an amount of money tendered for goods or services, and includes all applicable taxes less all unconditional discounts;
- (c) “**rand value**” means the total estimated value of a contract in Rand, calculated at the time of bid invitation, and includes all applicable taxes;
- (d) “**tender for income-generating contracts**” means a written offer in the form determined by an organ of state in response to an invitation for the origination of income-generating contracts through any method envisaged in legislation that will result in a legal agreement between the organ of state and a third party that produces revenue for the organ of state, and includes, but is not limited to, leasing and disposal of assets and concession contracts, excluding direct sales and disposal of assets through public auctions; and
- (e) “**the Act**” means the Preferential Procurement Policy Framework Act, 2000 (Act No. 5 of 2000).

3. FORMULAE FOR PROCUREMENT OF GOODS AND SERVICES

3.1. POINTS AWARDED FOR PRICE

3.1.1 THE 80/20 OR 90/10 PREFERENCE POINT SYSTEMS

A maximum of 80 or 90 points is allocated for price on the following basis:

$$\begin{array}{ccc}
 \mathbf{80/20} & \mathbf{or} & \mathbf{90/10} \\
 \\
 \mathbf{P_s = 80 \left(1 - \frac{P_t - P_{min}}{P_{min}} \right)} & \mathbf{or} & \mathbf{P_s = 90 \left(1 - \frac{P_t - P_{min}}{P_{min}} \right)}
 \end{array}$$

Where

- P_s = Points scored for price of tender under consideration
 P_t = Price of tender under consideration
 P_{min} = Price of lowest acceptable tender

3.2. FORMULAE FOR DISPOSAL OR LEASING OF STATE ASSETS AND INCOME GENERATING PROCUREMENT

3.2.1. POINTS AWARDED FOR PRICE

A maximum of 90 points is allocated for price on the following basis:

90/10

Type equation here.
$$Ps = 90 \left(1 + \frac{Pt - Pmax}{Pmax} \right)$$

Where

- Ps = Points scored for price of tender under consideration
- Pt = Price of tender under consideration
- Pmax = Price of highest acceptable tender

4. POINTS AWARDED FOR SPECIFIC GOALS

- 4.1. In terms of Regulation 4(2); 5(2); 6(2) and 7(2) of the Preferential Procurement Regulations, preference points must be awarded for specific goals stated in the tender. For the purposes of this tender the tenderer will be allocated points based on the goals stated in table 1 below as may be supported by proof/ documentation stated in the conditions of this tender:
- 4.2. In cases where organs of state intend to use Regulation 3(2) of the Regulations, which states that, if it is unclear whether the 80/20 or 90/10 preference point system applies, an organ of state must, in the tender documents, stipulate in the case of—
 - (a) an invitation for tender for income-generating contracts, that either the 80/20 or 90/10 preference point system will apply and that the highest acceptable tender will be used to determine the applicable preference point system; or
 - (b) any other invitation for tender, that either the 80/20 or 90/10 preference point system will apply and that the lowest acceptable tender will be used to determine the applicable preference point system,then the organ of state must indicate the points allocated for specific goals for both the 90/10 and 80/20 preference point system.

Table 1: Specific goals for the tender and points claimed are indicated per the table below.

(Note to organs of state: Where either the 90/10 or 80/20 preference point system is applicable, corresponding points must also be indicated as such.

Note to tenderers: The tenderer must indicate how they claim points for each preference point system.)

The specific goals allocated points in terms of this tender	Number of points allocated (90/10 system) (To be completed by the organ of state)	Number of points claimed (90/10 system) (To be completed by the tenderer)
B-BBEE Status level of Contributor	5	
1	3	
2	2	
3, 4, 5, 6, 7, 8 and Non-compliant contributor	0	
Enterprises located in a specific District Municipality, Township or region for work to be done or services to be rendered in that area (Mandatory)	2	
Residing within the North West Province where the service is required.	2	
Residing outside the North West Province	0	
Designated Groups (any bid that meets 1 or more of the 3 will get the maximum points)	3	
<ul style="list-style-type: none"> • Enterprises 51% owned by black women. • Enterprises 51% owned by people with disability. • Registered Cooperatives within the North West. 	3	

DECLARATION WITH REGARD TO COMPANY/FIRM

4.3. Name of company/firm.....

4.4. Company registration number:

4.5. TYPE OF COMPANY/ FIRM

- Partnership/Joint Venture / Consortium
- One-person business/sole propriety
- Close corporation
- Public Company
- Personal Liability Company

(Pty) Limited
Non-Profit Company
State Owned Company
[TICK APPLICABLE BOX]

- 4.6. I, the undersigned, who is duly authorised to do so on behalf of the company/firm, certify that the points claimed, based on the specific goals as advised in the tender, qualifies the company/ firm for the preference(s) shown and I acknowledge that:
- i) The information furnished is true and correct;
 - ii) The preference points claimed are in accordance with the General Conditions as indicated in paragraph 1 of this form;
 - iii) In the event of a contract being awarded as a result of points claimed as shown in paragraphs 1.4 and 4.2, the contractor may be required to furnish documentary proof to the satisfaction of the organ of state that the claims are correct;
 - iv) If the specific goals have been claimed or obtained on a fraudulent basis or any of the conditions of contract have not been fulfilled, the organ of state may, in addition to any other remedy it may have –
 - (a) disqualify the person from the tendering process;
 - (b) recover costs, losses or damages it has incurred or suffered as a result of that person's conduct;
 - (c) cancel the contract and claim any damages which it has suffered as a result of having to make less favourable arrangements due to such cancellation;
 - (d) recommend that the tenderer or contractor, its shareholders and directors, or only the shareholders and directors who acted on a fraudulent basis, be restricted from obtaining business from any organ of state for a period not exceeding 10 years, after the *audi alteram partem* (hear the other side) rule has been applied; and
 - (e) forward the matter for criminal prosecution, if deemed necessary.

..... SIGNATURE(S) OF TENDERER(S)	
SURNAME AND NAME:
DATE:
ADDRESS:

THE NATIONAL TREASURY

Republic of South Africa



GOVERNMENT PROCUREMENT: GENERAL CONDITIONS OF CONTRACT

July 2010

GOVERNMENT PROCUREMENT
GENERAL CONDITIONS OF CONTRACT
July 2010

NOTES

The purpose of this document is to:

- (i) Draw special attention to certain general conditions applicable to government bids, contracts and orders; and
- (ii) To ensure that clients be familiar with regard to the rights and obligations of all parties involved in doing business with government.

In this document words in the singular also mean in the plural and vice versa and words in the masculine also mean in the feminine and neuter.

- The General Conditions of Contract will form part of all bid documents and may not be amended.
- Special Conditions of Contract (SCC) relevant to a specific bid, should be compiled separately for every bid (if applicable) and will supplement the General Conditions of Contract. Whenever there is a conflict, the provisions in the SCC shall prevail.

TABLE OF CLAUSES

1. Definitions
2. Application
3. General
4. Standards
5. Use of contract documents and information; inspection
6. Patent rights
7. Performance security
8. Inspections, tests and analysis
9. Packing
10. Delivery and documents
11. Insurance
12. Transportation
13. Incidental services
14. Spare parts
15. Warranty
16. Payment
17. Prices
18. Contract amendments
19. Assignment
20. Subcontracts
21. Delays in the supplier's performance
22. Penalties
23. Termination for default
24. Dumping and countervailing duties
25. Force Majeure
26. Termination for insolvency
27. Settlement of disputes
28. Limitation of liability
29. Governing language
30. Applicable law
31. Notices
32. Taxes and duties
33. National Industrial Participation Programme (NIPP)
34. Prohibition of restrictive practices

General Conditions of Contract

1. Definitions

1. The following terms shall be interpreted as indicated:
 - 1.1 “Closing time” means the date and hour specified in the bidding documents for the receipt of bids.
 - 1.2 “Contract” means the written agreement entered into between the purchaser and the supplier, as recorded in the contract form signed by the parties, including all attachments and appendices thereto and all documents incorporated by reference therein.
 - 1.3 “Contract price” means the price payable to the supplier under the contract for the full and proper performance of his contractual obligations.
 - 1.4 “Corrupt practice” means the offering, giving, receiving, or soliciting of any thing of value to influence the action of a public official in the procurement process or in contract execution.
 - 1.5 "Countervailing duties" are imposed in cases where an enterprise abroad is subsidized by its government and encouraged to market its products internationally.
 - 1.6 “Country of origin” means the place where the goods were mined, grown or produced or from which the services are supplied. Goods are produced when, through manufacturing, processing or substantial and major assembly of components, a commercially recognized new product results that is substantially different in basic characteristics or in purpose or utility from its components.
 - 1.7 “Day” means calendar day.
 - 1.8 “Delivery” means delivery in compliance of the conditions of the contract or order.
 - 1.9 “Delivery ex stock” means immediate delivery directly from stock actually on hand.
 - 1.10 “Delivery into consignees store or to his site” means delivered and unloaded in the specified store or depot or on the specified site in compliance with the conditions of the contract or order, the supplier bearing all risks and charges involved until the supplies are so delivered and a valid receipt is obtained.
 - 1.11 "Dumping" occurs when a private enterprise abroad market its goods on own initiative in the RSA at lower prices than that of the country of origin and which have the potential to harm the local industries in the

RSA.

- 1.12 "Force majeure" means an event beyond the control of the supplier and not involving the supplier's fault or negligence and not foreseeable. Such events may include, but is not restricted to, acts of the purchaser in its sovereign capacity, wars or revolutions, fires, floods, epidemics, quarantine restrictions and freight embargoes.
- 1.13 "Fraudulent practice" means a misrepresentation of facts in order to influence a procurement process or the execution of a contract to the detriment of any bidder, and includes collusive practice among bidders (prior to or after bid submission) designed to establish bid prices at artificial non-competitive levels and to deprive the bidder of the benefits of free and open competition.
- 1.14 "GCC" means the General Conditions of Contract.
- 1.15 "Goods" means all of the equipment, machinery, and/or other materials that the supplier is required to supply to the purchaser under the contract.
- 1.16 "Imported content" means that portion of the bidding price represented by the cost of components, parts or materials which have been or are still to be imported (whether by the supplier or his subcontractors) and which costs are inclusive of the costs abroad, plus freight and other direct importation costs such as landing costs, dock dues, import duty, sales duty or other similar tax or duty at the South African place of entry as well as transportation and handling charges to the factory in the Republic where the supplies covered by the bid will be manufactured.
- 1.17 "Local content" means that portion of the bidding price which is not included in the imported content provided that local manufacture does take place.
- 1.18 "Manufacture" means the production of products in a factory using labour, materials, components and machinery and includes other related value-adding activities.
- 1.19 "Order" means an official written order issued for the supply of goods or works or the rendering of a service.
- 1.20 "Project site," where applicable, means the place indicated in bidding documents.
- 1.21 "Purchaser" means the organization purchasing the goods.
- 1.22 "Republic" means the Republic of South Africa.
- 1.23 "SCC" means the Special Conditions of Contract.
- 1.24 "Services" means those functional services ancillary to the supply of the goods, such as transportation and any other incidental services, such as installation, commissioning, provision of technical assistance, training, catering, gardening, security, maintenance and other such

obligations of the supplier covered under the contract.

1.25 “Written” or “in writing” means handwritten in ink or any form of electronic or mechanical writing.

2. Application

2.1 These general conditions are applicable to all bids, contracts and orders including bids for functional and professional services, sales, hiring, letting and the granting or acquiring of rights, but excluding immovable property, unless otherwise indicated in the bidding documents.

2.2 Where applicable, special conditions of contract are also laid down to cover specific supplies, services or works.

2.3 Where such special conditions of contract are in conflict with these general conditions, the special conditions shall apply.

3. General

3.1 Unless otherwise indicated in the bidding documents, the purchaser shall not be liable for any expense incurred in the preparation and submission of a bid. Where applicable a non-refundable fee for documents may be charged.

3.2 With certain exceptions, invitations to bid are only published in the Government Tender Bulletin. The Government Tender Bulletin may be obtained directly from the Government Printer, Private Bag X85, Pretoria 0001, or accessed electronically from www.treasury.gov.za

4. Standards

4.1 The goods supplied shall conform to the standards mentioned in the bidding documents and specifications.

5. Use of contract documents and information; inspection.

5.1 The supplier shall not, without the purchaser’s prior written consent, disclose the contract, or any provision thereof, or any specification, plan, drawing, pattern, sample, or information furnished by or on behalf of the purchaser in connection therewith, to any person other than a person employed by the supplier in the performance of the contract. Disclosure to any such employed person shall be made in confidence and shall extend only so far as may be necessary for purposes of such performance.

5.2 The supplier shall not, without the purchaser’s prior written consent, make use of any document or information mentioned in GCC clause 5.1 except for purposes of performing the contract.

5.3 Any document, other than the contract itself mentioned in GCC clause 5.1 shall remain the property of the purchaser and shall be returned (all copies) to the purchaser on completion of the supplier’s performance under the contract if so required by the purchaser.

5.4 The supplier shall permit the purchaser to inspect the supplier’s records relating to the performance of the supplier and to have them audited by auditors appointed by the purchaser, if so required by the purchaser.

6. Patent rights

6.1 The supplier shall indemnify the purchaser against all third-party claims of infringement of patent, trademark, or industrial design rights arising from use of the goods or any part thereof by the purchaser.

7. Performance security

- 7.1 Within thirty (30) days of receipt of the notification of contract award, the successful bidder shall furnish to the purchaser the performance security of the amount specified in SCC.
- 7.2 The proceeds of the performance security shall be payable to the purchaser as compensation for any loss resulting from the supplier's failure to complete his obligations under the contract.
- 7.3 The performance security shall be denominated in the currency of the contract, or in a freely convertible currency acceptable to the purchaser and shall be in one of the following forms:
 - (a) a bank guarantee or an irrevocable letter of credit issued by a reputable bank located in the purchaser's country or abroad, acceptable to the purchaser, in the form provided in the bidding documents or another form acceptable to the purchaser; or
 - (b) a cashier's or certified cheque
- 7.4 The performance security will be discharged by the purchaser and returned to the supplier not later than thirty (30) days following the date of completion of the supplier's performance obligations under the contract, including any warranty obligations, unless otherwise specified in SCC.

8. Inspections, tests and analyses

- 8.1 All pre-bidding testing will be for the account of the bidder.
- 8.2 If it is a bid condition that supplies to be produced or services to be rendered should at any stage during production or execution or on completion be subject to inspection, the premises of the bidder or contractor shall be open, at all reasonable hours, for inspection by a representative of the Department or an organization acting on behalf of the Department.
- 8.3 If there are no inspection requirements indicated in the bidding documents and no mention is made in the contract, but during the contract period it is decided that inspections shall be carried out, the purchaser shall itself make the necessary arrangements, including payment arrangements with the testing authority concerned.
- 8.4 If the inspections, tests and analyses referred to in clauses 8.2 and 8.3 show the supplies to be in accordance with the contract requirements, the cost of the inspections, tests and analyses shall be defrayed by the purchaser.
- 8.5 Where the supplies or services referred to in clauses 8.2 and 8.3 do not comply with the contract requirements, irrespective of whether such supplies or services are accepted or not, the cost in connection with these inspections, tests or analyses shall be defrayed by the supplier.
- 8.6 Supplies and services which are referred to in clauses 8.2 and 8.3 and which do not comply with the contract requirements may be rejected.
- 8.7 Any contract supplies may on or after delivery be inspected, tested or

analyzed and may be rejected if found not to comply with the requirements of the contract. Such rejected supplies shall be held at the cost and risk of the supplier who shall, when called upon, remove them immediately at his own cost and forthwith substitute them with supplies which do comply with the requirements of the contract. Failing such removal the rejected supplies shall be returned at the suppliers cost and risk. Should the supplier fail to provide the substitute supplies forthwith, the purchaser may, without giving the supplier further opportunity to substitute the rejected supplies, purchase such supplies as may be necessary at the expense of the supplier.

8.8 The provisions of clauses 8.4 to 8.7 shall not prejudice the right of the purchaser to cancel the contract on account of a breach of the conditions thereof, or to act in terms of Clause 23 of GCC.

9. Packing

9.1 The supplier shall provide such packing of the goods as is required to prevent their damage or deterioration during transit to their final destination, as indicated in the contract. The packing shall be sufficient to withstand, without limitation, rough handling during transit and exposure to extreme temperatures, salt and precipitation during transit, and open storage. Packing, case size and weights shall take into consideration, where appropriate, the remoteness of the goods' final destination and the absence of heavy handling facilities at all points in transit.

9.2 The packing, marking, and documentation within and outside the packages shall comply strictly with such special requirements as shall be expressly provided for in the contract, including additional requirements, if any, specified in SCC, and in any subsequent instructions ordered by the purchaser.

10. Delivery and documents

10.1 Delivery of the goods shall be made by the supplier in accordance with the terms specified in the contract. The details of shipping and/or other documents to be furnished by the supplier are specified in SCC.

10.2 Documents to be submitted by the supplier are specified in SCC.

11. Insurance

11.1 The goods supplied under the contract shall be fully insured in a freely convertible currency against loss or damage incidental to manufacture or acquisition, transportation, storage and delivery in the manner specified in the SCC.

12. Transportation

12.1 Should a price other than an all-inclusive delivered price be required, this shall be specified in the SCC.

13. Incidental services

13.1 The supplier may be required to provide any or all of the following services, including additional services, if any, specified in SCC:

- (a) performance or supervision of on-site assembly and/or commissioning of the supplied goods;
- (b) furnishing of tools required for assembly and/or maintenance of the supplied goods;
- (c) furnishing of a detailed operations and maintenance manual for each appropriate unit of the supplied goods;

- (d) performance or supervision or maintenance and/or repair of the supplied goods, for a period of time agreed by the parties, provided that this service shall not relieve the supplier of any warranty obligations under this contract; and
- (e) training of the purchaser's personnel, at the supplier's plant and/or on-site, in assembly, start-up, operation, maintenance, and/or repair of the supplied goods.

13.2 Prices charged by the supplier for incidental services, if not included in the contract price for the goods, shall be agreed upon in advance by the parties and shall not exceed the prevailing rates charged to other parties by the supplier for similar services.

14. Spare parts

14.1 As specified in SCC, the supplier may be required to provide any or all of the following materials, notifications, and information pertaining to spare parts manufactured or distributed by the supplier:

- (a) such spare parts as the purchaser may elect to purchase from the supplier, provided that this election shall not relieve the supplier of any warranty obligations under the contract; and
- (b) in the event of termination of production of the spare parts:
 - (i) Advance notification to the purchaser of the pending termination, in sufficient time to permit the purchaser to procure needed requirements; and
 - (ii) following such termination, furnishing at no cost to the purchaser, the blueprints, drawings, and specifications of the spare parts, if requested.

15. Warranty

15.1 The supplier warrants that the goods supplied under the contract are new, unused, of the most recent or current models, and that they incorporate all recent improvements in design and materials unless provided otherwise in the contract. The supplier further warrants that all goods supplied under this contract shall have no defect, arising from design, materials, or workmanship (except when the design and/or material is required by the purchaser's specifications) or from any act or omission of the supplier, that may develop under normal use of the supplied goods in the conditions prevailing in the country of final destination.

15.2 This warranty shall remain valid for twelve (12) months after the goods, or any portion thereof as the case may be, have been delivered to and accepted at the final destination indicated in the contract, or for eighteen (18) months after the date of shipment from the port or place of loading in the source country, whichever period concludes earlier, unless specified otherwise in SCC.

15.3 The purchaser shall promptly notify the supplier in writing of any claims arising under this warranty.

15.4 Upon receipt of such notice, the supplier shall, within the period specified in SCC and with all reasonable speed, repair or replace the defective goods or parts thereof, without costs to the purchaser.

15.5 If the supplier, having been notified, fails to remedy the defect(s) within the period specified in SCC, the purchaser may proceed to take

such remedial action as may be necessary, at the supplier's risk and expense and without prejudice to any other rights which the purchaser may have against the supplier under the contract.

- 16. Payment**
- 16.1 The method and conditions of payment to be made to the supplier under this contract shall be specified in SCC.
- 16.2 The supplier shall furnish the purchaser with an invoice accompanied by a copy of the delivery note and upon fulfillment of other obligations stipulated in the contract.
- 16.3 Payments shall be made promptly by the purchaser, but in no case later than thirty (30) days after submission of an invoice or claim by the supplier.
- 16.4 Payment will be made in Rand unless otherwise stipulated in SCC.
- 17. Prices**
- 17.1 Prices charged by the supplier for goods delivered and services performed under the contract shall not vary from the prices quoted by the supplier in his bid, with the exception of any price adjustments authorized in SCC or in the purchaser's request for bid validity extension, as the case may be.
- 18. Contract amendments**
- 18.1 No variation in or modification of the terms of the contract shall be made except by written amendment signed by the parties concerned.
- 19. Assignment**
- 19.1 The supplier shall not assign, in whole or in part, its obligations to perform under the contract, except with the purchaser's prior written consent.
- 20. Subcontracts**
- 20.1 The supplier shall notify the purchaser in writing of all subcontracts awarded under this contracts if not already specified in the bid. Such notification, in the original bid or later, shall not relieve the supplier from any liability or obligation under the contract.
- 21. Delays in the supplier's performance**
- 21.1 Delivery of the goods and performance of services shall be made by the supplier in accordance with the time schedule prescribed by the purchaser in the contract.
- 21.2 If at any time during performance of the contract, the supplier or its subcontractor(s) should encounter conditions impeding timely delivery of the goods and performance of services, the supplier shall promptly notify the purchaser in writing of the fact of the delay, its likely duration and its cause(s). As soon as practicable after receipt of the supplier's notice, the purchaser shall evaluate the situation and may at his discretion extend the supplier's time for performance, with or without the imposition of penalties, in which case the extension shall be ratified by the parties by amendment of contract.
- 21.3 No provision in a contract shall be deemed to prohibit the obtaining of supplies or services from a national department, provincial department, or a local authority.
- 21.4 The right is reserved to procure outside of the contract small quantities or to have minor essential services executed if an emergency arises, the

supplier's point of supply is not situated at or near the place where the supplies are required, or the supplier's services are not readily available.

21.5 Except as provided under GCC Clause 25, a delay by the supplier in the performance of its delivery obligations shall render the supplier liable to the imposition of penalties, pursuant to GCC Clause 22, unless an extension of time is agreed upon pursuant to GCC Clause 21.2 without the application of penalties.

21.6 Upon any delay beyond the delivery period in the case of a supplies contract, the purchaser shall, without canceling the contract, be entitled to purchase supplies of a similar quality and up to the same quantity in substitution of the goods not supplied in conformity with the contract and to return any goods delivered later at the supplier's expense and risk, or to cancel the contract and buy such goods as may be required to complete the contract and without prejudice to his other rights, be entitled to claim damages from the supplier.

22. Penalties

22.1 Subject to GCC Clause 25, if the supplier fails to deliver any or all of the goods or to perform the services within the period(s) specified in the contract, the purchaser shall, without prejudice to its other remedies under the contract, deduct from the contract price, as a penalty, a sum calculated on the delivered price of the delayed goods or unperformed services using the current prime interest rate calculated for each day of the delay until actual delivery or performance. The purchaser may also consider termination of the contract pursuant to GCC Clause 23.

23. Termination for default

23.1 The purchaser, without prejudice to any other remedy for breach of contract, by written notice of default sent to the supplier, may terminate this contract in whole or in part:

- (a) if the supplier fails to deliver any or all of the goods within the period(s) specified in the contract, or within any extension thereof granted by the purchaser pursuant to GCC Clause 21.2;
- (b) if the Supplier fails to perform any other obligation(s) under the contract; or
- (c) if the supplier, in the judgment of the purchaser, has engaged in corrupt or fraudulent practices in competing for or in executing the contract.

23.2 In the event the purchaser terminates the contract in whole or in part, the purchaser may procure, upon such terms and in such manner as it deems appropriate, goods, works or services similar to those undelivered, and the supplier shall be liable to the purchaser for any excess costs for such similar goods, works or services. However, the supplier shall continue performance of the contract to the extent not terminated.

23.3 Where the purchaser terminates the contract in whole or in part, the purchaser may decide to impose a restriction penalty on the supplier by prohibiting such supplier from doing business with the public sector for a period not exceeding 10 years.

23.4 If a purchaser intends imposing a restriction on a supplier or any

person associated with the supplier, the supplier will be allowed a time period of not more than fourteen (14) days to provide reasons why the envisaged restriction should not be imposed. Should the supplier fail to respond within the stipulated fourteen (14) days the purchaser may regard the intended penalty as not objected against and may impose it on the supplier.

23.5 Any restriction imposed on any person by the Accounting Officer / Authority will, at the discretion of the Accounting Officer / Authority, also be applicable to any other enterprise or any partner, manager, director or other person who wholly or partly exercises or exercised or may exercise control over the enterprise of the first-mentioned person, and with which enterprise or person the first-mentioned person, is or was in the opinion of the Accounting Officer / Authority actively associated.

23.6 If a restriction is imposed, the purchaser must, within five (5) working days of such imposition, furnish the National Treasury, with the following information:

- (i) the name and address of the supplier and / or person restricted by the purchaser;
- (ii) the date of commencement of the restriction
- (iii) the period of restriction; and
- (iv) the reasons for the restriction.

These details will be loaded in the National Treasury's central database of suppliers or persons prohibited from doing business with the public sector.

23.7 If a court of law convicts a person of an offence as contemplated in sections 12 or 13 of the Prevention and Combating of Corrupt Activities Act, No. 12 of 2004, the court may also rule that such person's name be endorsed on the Register for Tender Defaulters. When a person's name has been endorsed on the Register, the person will be prohibited from doing business with the public sector for a period not less than five years and not more than 10 years. The National Treasury is empowered to determine the period of restriction and each case will be dealt with on its own merits. According to section 32 of the Act the Register must be open to the public. The Register can be perused on the National Treasury website.

24. Anti-dumping and countervailing duties and rights

24.1 When, after the date of bid, provisional payments are required, or anti-dumping or countervailing duties are imposed, or the amount of a provisional payment or anti-dumping or countervailing right is increased in respect of any dumped or subsidized import, the State is not liable for any amount so required or imposed, or for the amount of any such increase. When, after the said date, such a provisional payment is no longer required or any such anti-dumping or countervailing right is abolished, or where the amount of such provisional payment or any such right is reduced, any such favourable difference shall on demand be paid forthwith by the contractor to the State or the State may deduct such amounts from moneys (if any) which may otherwise be due to the contractor in regard to supplies or services which he delivered or rendered, or is to deliver or render in terms of the contract or any other contract or any other amount which

may be due to him

25. Force Majeure

- 25.1 Notwithstanding the provisions of GCC Clauses 22 and 23, the supplier shall not be liable for forfeiture of its performance security, damages, or termination for default if and to the extent that his delay in performance or other failure to perform his obligations under the contract is the result of an event of force majeure.
- 25.2 If a force majeure situation arises, the supplier shall promptly notify the purchaser in writing of such condition and the cause thereof. Unless otherwise directed by the purchaser in writing, the supplier shall continue to perform its obligations under the contract as far as is reasonably practical, and shall seek all reasonable alternative means for performance not prevented by the force majeure event.

26. Termination for insolvency

- 26.1 The purchaser may at any time terminate the contract by giving written notice to the supplier if the supplier becomes bankrupt or otherwise insolvent. In this event, termination will be without compensation to the supplier, provided that such termination will not prejudice or affect any right of action or remedy which has accrued or will accrue thereafter to the purchaser.

27. Settlement of Disputes

- 27.1 If any dispute or difference of any kind whatsoever arises between the purchaser and the supplier in connection with or arising out of the contract, the parties shall make every effort to resolve amicably such dispute or difference by mutual consultation.
- 27.2 If, after thirty (30) days, the parties have failed to resolve their dispute or difference by such mutual consultation, then either the purchaser or the supplier may give notice to the other party of his intention to commence with mediation. No mediation in respect of this matter may be commenced unless such notice is given to the other party.
- 27.3 Should it not be possible to settle a dispute by means of mediation, it may be settled in a South African court of law.
- 27.4 Mediation proceedings shall be conducted in accordance with the rules of procedure specified in the SCC.
- 27.5 Notwithstanding any reference to mediation and/or court proceedings herein,
- (a) the parties shall continue to perform their respective obligations under the contract unless they otherwise agree; and
 - (b) the purchaser shall pay the supplier any monies due the supplier.

28. Limitation of liability

- 28.1 Except in cases of criminal negligence or willful misconduct, and in the case of infringement pursuant to Clause 6;
- (a) the supplier shall not be liable to the purchaser, whether in contract, tort, or otherwise, for any indirect or consequential loss or damage, loss of use, loss of production, or loss of profits or interest costs, provided that this exclusion shall not apply to any obligation of the supplier to pay penalties and/or damages to the purchaser; and

- (b) the aggregate liability of the supplier to the purchaser, whether under the contract, in tort or otherwise, shall not exceed the total contract price, provided that this limitation shall not apply to the cost of repairing or replacing defective equipment.
- 29. Governing language** 29.1 The contract shall be written in English. All correspondence and other documents pertaining to the contract that is exchanged by the parties shall also be written in English.
- 30. Applicable law** 30.1 The contract shall be interpreted in accordance with South African laws, unless otherwise specified in SCC.
- 31. Notices** 31.1 Every written acceptance of a bid shall be posted to the supplier concerned by registered or certified mail and any other notice to him shall be posted by ordinary mail to the address furnished in his bid or to the address notified later by him in writing and such posting shall be deemed to be proper service of such notice
- 31.2 The time mentioned in the contract documents for performing any act after such aforesaid notice has been given, shall be reckoned from the date of posting of such notice.
- 32. Taxes and duties** 32.1 A foreign supplier shall be entirely responsible for all taxes, stamp duties, license fees, and other such levies imposed outside the purchaser's country.
- 32.2 A local supplier shall be entirely responsible for all taxes, duties, license fees, etc., incurred until delivery of the contracted goods to the purchaser.
- 32.3 No contract shall be concluded with any bidder whose tax matters are not in order. Prior to the award of a bid the Department must be in possession of a tax clearance certificate, submitted by the bidder. This certificate must be an original issued by the South African Revenue Services.
- 33. National Industrial Participation Programme (NIP)** 33.1 The NIP Programme administered by the Department of Trade and Industry shall be applicable to all contracts that are subject to the NIP obligation.
- 34 Prohibition of Restrictive practices** 34.1 In terms of section 4 (1) (b) (iii) of the Competition Act No. 89 of 1998, as amended, an agreement between, or concerted practice by, firms, or a decision by an association of firms, is prohibited if it is between parties in a horizontal relationship and if a bidder (s) is / are or a contractor(s) was / were involved in collusive bidding (or bid rigging).
- 34.2 If a bidder(s) or contractor(s), based on reasonable grounds or evidence obtained by the purchaser, has / have engaged in the restrictive practice referred to above, the purchaser may refer the matter to the Competition Commission for investigation and possible imposition of administrative penalties as contemplated in the Competition Act No. 89 of 1998.

- 34.3 If a bidder(s) or contractor(s), has / have been found guilty by the Competition Commission of the restrictive practice referred to above, the purchaser may, in addition and without prejudice to any other remedy provided for, invalidate the bid(s) for such item(s) offered, and / or terminate the contract in whole or part, and / or restrict the bidder(s) or contractor(s) from conducting business with the public sector for a period not exceeding ten (10) years and / or claim damages from the bidder(s) or contractor(s) concerned.