

Title: **NEW OIL FILLED AUXILIARY  
TRANSFORMERS RATED 1 MVA  
AND BELOW AND 33KV AND  
BELOW**

Unique Identifier: **240-57648800**

Alternative Reference Number: **<n/a>**

Area of Applicability: **Engineering**

Documentation Type: **Standard**

Revision: **3**

Total Pages: **61**

Next Review Date: **November 2019**

Disclosure Classification: **Controlled  
Disclosure**

Compiled by



**Carl Wolmarans**

**Engineer – Transformers  
and Reactors Designation**

Date: **15/11/2014**

Approved by



**Sidwell Mtetwa**

**Corporate Specialist**

Date: **17/11/2014**

Authorized by

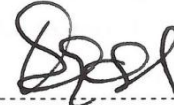

**Bheki Ntshangase**

**Senior Manager— HV Plant  
– PDE**

Date: **18/11/2014**

**Supported by SCOT/SC**

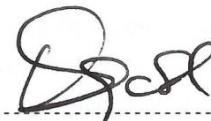

**Bheki Ntshangase  
SCOT PE SC Chairperson**

Date: **18/11/2014**

## Content

	Page
1. Introduction .....	7
2. Supporting clauses .....	7
2.1 Scope .....	7
2.1.1 Purpose .....	7
2.1.2 Applicability .....	7
2.2 Normative/informative references .....	7
2.2.1 Normative .....	7
2.2.2 Informative .....	8
2.3 Definitions .....	8
2.3.1 General .....	8
2.3.2 Disclosure classification .....	8
2.4 Abbreviations .....	8
2.5 Roles and responsibilities .....	10
2.6 Process for monitoring .....	10
2.7 Related/supporting documents .....	10
3. Site Conditions .....	10
4. Service Conditions .....	10
4.1 Frequency .....	10
4.2 Loading Conditions for Temperature Rise Limits .....	10
5. Terminal Arrangement .....	10
5.1 Relative terminal positioning .....	10
5.2 Terminal types .....	11
5.2.1 Primary Outdoor Bushings .....	11
5.2.2 Primary Cable Box/Enclosure .....	11
5.2.3 LV Cable Box .....	13
5.2.4 Circuit breaker (LV) .....	16
6. Outdoor Bushings .....	17
7. Insulation Levels .....	17
8. Nameplate and Labeling Details .....	18
8.1 General .....	18
8.2 Materials, Marking and Mounting .....	18
8.2.1 Rating and diagram plates .....	18
8.2.2 General Labeling .....	18
8.2.3 Terminal Labels .....	19
8.2.4 De-Energized Tap Changer (DETC) Label .....	19
8.2.5 Cable box labeling .....	19
9. Information to be displayed .....	19
9.1 Rating plates .....	19
10. Core Design Requirements .....	20
10.1 Material .....	20
10.2 Design .....	20
10.3 Core Earthing .....	20
10.4 Core and Supporting Structure Temperatures .....	20

**ESKOM COPYRIGHT PROTECTED**

---

10.5	Electrical Continuity.....	20
10.6	Insulation of the Core .....	21
10.7	Earthing of the Core Clamping Structure .....	21
10.8	Lock-nuts/ locking plates .....	21
10.9	Lifting Facilities for Active Part .....	21
11.	Winding Design Requirements .....	21
11.1	Material.....	21
11.2	Design .....	21
11.3	Hot-spot Calculations .....	21
11.4	Insulation Design.....	22
11.5	Internal Connections .....	22
11.6	Short-circuit capability .....	22
11.7	Sizing and compression of windings .....	22
12.	De-energized Tap changers Requirements (DETC) .....	23
12.1	General.....	23
12.2	Tapping ranges .....	23
13.	Factory Testing.....	23
13.1	Dielectric test levels.....	24
13.2	Typical Type Test Reports .....	24
13.3	Typical Test Plan.....	24
13.4	Temperature Rise.....	24
13.5	Winding Rise .....	24
13.6	Winding Hottest Spot Temperature Rise.....	24
13.7	Top Oil Rise.....	24
13.8	Temperature Rise of Metallic Parts at Rated MVA .....	24
13.9	Sound Level .....	25
14.	Inspection at the Manufactures Factory .....	25
15.	Insulating Oils .....	25
15.1	General.....	25
15.2	Oil-filling and impregnation under vacuum.....	25
16.	Main Tank Construction.....	25
16.1	General.....	25
16.2	Materials and Welding.....	26
16.3	Corrosion Protection and Paint Finish.....	26
16.4	Tank Shape .....	26
16.5	Cooling Corrugations.....	26
16.6	Guides for Core and Winding Assembly .....	26
16.7	Fasteners .....	26
16.8	Tank Strength and Oil Tightness.....	26
16.8.1	Rigidity .....	26
16.8.2	Internal pressure and vacuum .....	26
16.8.3	Tank base construction.....	26
16.8.4	Partial drain indication level on tank .....	27
16.9	Lifting Lugs .....	27
16.10	Hand holes .....	27
16.11	Gaskets .....	27
16.12	Bleeding Points .....	27

---

16.13	Earthing Pads and Cleats .....	27
17.	Conservator Tank Construction .....	27
17.1	Capacity .....	27
17.2	Strength .....	27
17.3	Mounting .....	27
17.4	Sump .....	28
17.5	Removable Covers .....	28
17.6	Pipework Connections .....	28
18.	Cooling .....	28
18.1	General .....	28
18.2	Cooling Systems .....	28
19.	Valves .....	28
19.1	Drain Valve .....	29
19.2	Conservator isolating and drain Valve .....	29
20.	Oil Temperature Indicator .....	29
21.	Oil Level Indicator .....	29
22.	Oil Sample Points .....	29
23.	Gas and Oil Actuated Relay (Buchholz) .....	29
24.	Dehydrating Breather .....	29
25.	Alarm and Trip Termination .....	29
25.1	Alarm Signalling .....	29
25.2	Trip Signalling .....	30
26.	Current Transformers .....	30
27.	Shipment Preparation .....	30
28.	Main Tank and Accessories .....	30
29.	Impact indicator .....	30
30.	Transport .....	30
30.1	General Conditions .....	30
30.2	Sea Transport .....	30
30.3	Road Transport .....	30
31.	Installation and Erection .....	31
31.1	General .....	31
31.2	Foundation Tolerances and Transformer Layout Details .....	31
31.3	Site Installation .....	31
31.4	Functional Tests .....	31
31.5	Electrical Tests, Meeting Requirements of IEC 60076 .....	31
32.	Auxiliary Supplies, Terminal Boxes, Wiring and Cabling .....	31
32.1	Supply Voltage .....	31
32.2	Terminal Boxes .....	32
32.3	Spare terminals .....	32
32.4	Incoming auxiliary circuits .....	32
32.5	Provision for outgoing cables .....	32
32.6	Cabling and Wiring .....	32
32.7	Insulation .....	32

---

32.8	Insulation test voltage.....	32
32.9	Type of conductor.....	32
32.10	Supporting and securing of cables.....	33
32.11	Identification of wiring.....	33
32.12	Identification of fuses.....	33
32.13	Identification of equipment .....	33
33.	Secondary Terminations.....	33
33.1	General.....	33
33.2	Mounting of terminal blocks .....	33
33.3	Spring loaded terminal blocks .....	34
34.	Documentation .....	35
35.	Design Review Meeting.....	35
36.	Losses .....	36
36.1	Guaranteed Losses .....	36
36.2	Non-Conformance .....	36
36.3	Loss EVALUATION.....	36
37.	Quality Assurance .....	37
38.	Local Technical Support.....	37
38.1	Support requirements.....	37
39.	Authorization.....	38
40.	Revisions .....	39
41.	Development team .....	39
42.	Acknowledgements .....	40
	Annex A – Typical A/B Schedule.....	41

**Figures**

Figure 1:	Relative Terminal position, Labels A, B, C Primary HV, Labels n, a, b , c Secondary LV .....	11
Figure 2:	33kV (screened separable) connector dimensions .....	12
Figure 3:	33kV HV cable termination enclosure dimensions, 'a' in accordance with SANS 876 .....	13
Figure 4:	Minimum clearances between cable terminals and enclosure in Secondary (LV) cable box .....	14
Figure 5:	LV cable phase to phase clearance .....	15
Figure 6:	Gland plate hole positions, 1 cable .....	15
Figure 7:	Gland plate hole positions, 2 cables .....	16
Figure 8:	Gland plate hole positions, 3 cables .....	16
Figure 9:	Gland plate hole positions, 6 cables .....	16
Figure 10:	Spring-loaded terminal blocks .....	34

**Tables**

Table 1:	HV Outdoor Bushing Voltage Levels .....	11
Table 2:	Cable Sizes for secondary cable boxes .....	14
Table 3:	Insulation levels for the different typical voltage levels, in installations where the transformer is exposed (i.e. primary bushing used outdoors).....	17

**ESKOM COPYRIGHT PROTECTED**

Table 4: Insulation levels for the different typical voltage levels, in installations where the transformer is not exposed (i.e. such as those connected to cable networks on the primary) .....18

Table 5: Tests to be performed .....23

Table 6: Permissible increase of gas in oil during temperature rise testing .....24

Table 7: Indication of loss factors .....36

## **1. Introduction**

This specification supersedes the previous specifications pertaining to oil-filled auxiliary transformers for each Eskom division namely TSP 41-121 and 474-038 (for units less than 1 MVA and including but, less than 33kV).

## **2. Supporting clauses**

### **2.1 Scope**

Oil-filled Auxiliary transformers are used in both substation and power station environments to supply power to required loads. The requirements are specified in this document to ensure integrity of above normal standard, thereby minimizing the risk of failure and/or disruption of major loads. These transformers are also specified so that they require minimum intervention when they are in service to support the drive for reduced maintenance.

The requirements set out in this specification for auxiliary transformers are made taking into consideration that they are connected to the tertiary winding of network transformers that cost more than 50 times the cost of an auxiliary transformer in most cases.

The specification applies, throughout Eskom to transformers rated less than 1000 kVA, with a primary-voltage rating of 33kV (+- 5%) and below, and a secondary-voltage rating of 400 V.

This specification defines minimum requirements for design, manufacturing, construction, testing, delivery, installation, commissioning and performance. The transformer manufacturer shall apply the best internationally accepted engineering and manufacturing standards to produce an auxiliary transformer, including accessories, which in conjunction with normal maintenance, will result in a safe and reliable service through a 40-year life under the rigors of service in an electric utility power system.

The manufacturer shall comply with all requirements of this specification. All proposed deviations from these requirements must be brought to the attention of Eskom in the manufacturer's proposal. No deviations will be allowed after the award of the contract. The manufacturer shall bring any conflict with standards or between different parts of the specification to the attention of Eskom prior to any design or manufacturing.

Acceptance of the tender return documents, the manufacturing drawings, the design review, procedures and tests or inspections by Eskom shall not relieve the manufacturer of the responsibility of meeting the requirements of this specification, of standards or of the purchaser's contract.

#### **2.1.1 Purpose**

This document sets out the technical specifications for oil filled auxiliary transformer 1 MVA and below and 33kV and below for use in all Eskom divisions.

#### **2.1.2 Applicability**

This document shall apply throughout Eskom Holdings Limited Divisions.

## **2.2 Normative/informative references**

Parties using this document shall apply the most recent edition of the documents listed in the following paragraphs.

### **2.2.1 Normative**

- [1] SANS/IEC 60076 all part Power Transformers
- [2] EN 10025 Technical delivery conditions for structural steels
- [3] EN 1011:2001 parts 1 and 2 Recommendations for welding of metallic materials

**ESKOM COPYRIGHT PROTECTED**

- [4] SANS/IEC 60137 Bushings for alternating voltages above 1000 V
- [5] SANS 780 Specification for Distribution Transformers
- [6] SANS 876 (formerly NRS 012) Cable terminations and live conductors within air-insulated enclosures for rated a.c. voltages of 7,2 kV and up to and including 36 kV
- [7] SABS 156 Moulded case circuit breakers
- [8] TB 204 Cigre , Design reviews
- [9] 32-9 Definition of Eskom documents.
- [10] 32-644 Eskom documentation management standard
- [11] 474-65 Operating Manual of the Steering Committee of Technologies (SCOT)
- [12] 240-56063843 Winding and oil temperature specification
- [13] 240-56063908 Buchholz relay specification
- [14] 240-56062529 Breather specification
- [15] 240-56356191 Transformer and Reactor Oil Level Indicators
- [16] 240-56030674 Corrosion Protection of new and in-service power & station auxiliary transformers
- [17] 240-75661431 Mineral insulating oils (uninhibited and inhibited) part 1: purchase, management, maintenance and testing
- [18] 240-56062726 Standard for Intrusive work and Oil filling, under vacuum of transformers and reactors on site
- [19] QM 58 Eskom Quality Procedure
- [20] D-DT-3202 Eskom Drawing MV and LV cable box
- [21] 32-136 Eskom construction regulations
- [22] Eskom 10TB-018 Technical Bulletin for Loss Evaluation
- [23] TPC 41-246 Management of manufacturers and suppliers equipment drawings

## **2.2.2 Informative**

None

## **2.3 Definitions**

### **2.3.1 General**

All definitions as in IEC 60076-1 shall apply throughout.

### **2.3.2 Disclosure classification**

**Controlled disclosure:** controlled disclosure to external parties (either enforced by law, or discretionary).

## **2.4 Abbreviations**

<b>Abbreviation</b>	<b>Description</b>
<b>BIL</b>	Basic Insulation Level
<b>BS</b>	British Standard
<b>DETC</b>	De-Energized Tap Changer
<b>DIN</b>	Deutsches Institut für Normung

**ESKOM COPYRIGHT PROTECTED**



Abbreviation	Description
EP	Electrical Plant
HV	High/Highest Voltage
Hz	Hertz
IEC	International Electro-technical Commission
IP (55)	Ingress Protection
K	Kelvin
kA	Kilo-Amp
kV	Kilo-Volt
KVA	Kilo-Volt-Ampere
kW	Killo-watt
LAP	List of Accepted Products
LV	Low Voltage
MCCB	Moulded Case Circuit Breaker
MPa	Mega-Pascal
MV	Medium Voltage
MVA	Mega Volt Ampere
OEM	Original Equipment Manufacturer
OHS	Occupational Health and Safety
ONAN	Oil Natural Air Natural (Cooling)
PD	Partial Discharge
PDE	Power Delivery Engineering
PE	Plant Equipment
Pu	Per Unit
PVC	Polyvinyl Chloride
SANS	South African National Standards
SC	Steering Committee
SCOT	Steering Committee Of Technologies
SFRA	Sweep Frequency Response Analysis
SOW	Scope of Work
TC	Technical Committee
TOV	Temporary Over Voltage
Um	Maximum System Voltage
Un	Nominal System Voltage
UV	Ultra-Violet
VAC	Alternating-Current Voltage

**ESKOM COPYRIGHT PROTECTED**

Abbreviation	Description
VDC	Direct-Current Voltage

## 2.5 Roles and responsibilities

The Steering Committee Of Technologies (SCOT), Transformer Care Group (CG) is responsible for the updating and reviewing of this specification as necessary.

## 2.6 Process for monitoring

This document will be revised following the SCOT process as per the published review date on the front page of this document.

## 2.7 Related/supporting documents

All supporting documents are listed in the normative references. This specification must be used in conjunction with all referenced documents.

## 3. Site Conditions

Outdoor installation

Altitude above sea level – 1800m

Ambient temperatures Maximum + 40°C

Yearly average + 25°C

Minimum - 10°C

Relative humidity of 100%

Solar radiation 1.2 kW/m<sup>2</sup>

Pollution levels: very high requiring creepage of 31mm/kV throughout.

Atmospheric UV radiation = High

Seismic conditions at a minimum of 0.3g, this requirement must be proved by calculation.

## 4. Service Conditions

### 4.1 Frequency

The rated nominal frequency shall be 50Hz.

### 4.2 Loading Conditions for Temperature Rise Limits

The loading conditions for which the temperature rise limits presented in section 13 apply are according to the applicable standards of IEC 60076-7.

## 5. Terminal Arrangement

### 5.1 Relative terminal positioning

Terminals positions shall be specified in line with 1 below:

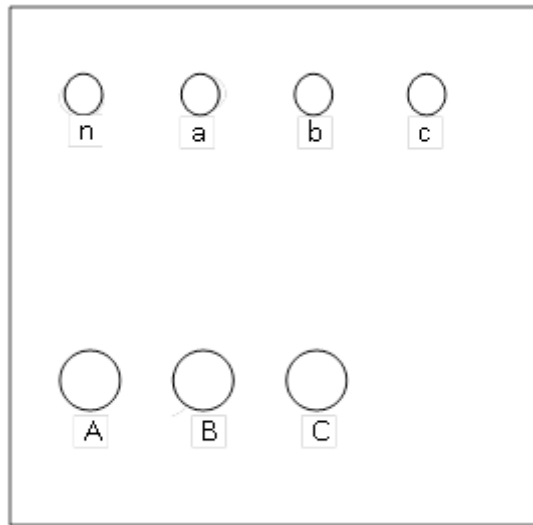

Figure 1: Relative Terminal position, Labels A, B, C Primary HV, Labels n, a, b , c Secondary LV

## 5.2 Terminal types

This section describes and specifies the terminal types that could be specified for a particular auxiliary transformer. The A/B schedules shall specify which terminal type to be used for the HV and LV respectively.

### 5.2.1 Primary Outdoor Bushings

The auxiliary transformers shall be equipped with Outdoor bushings on the HV side, and cable outlets controlled by moulded-case air circuit breakers on the LV side housed in an enclosure as described in section 5.2.3.

Table 1: HV Outdoor Bushing Voltage Levels

HV Voltage (Un, kV)	HV Bushing/Terminal Rated Voltage (kV)	Minimum phase-to-phase clearance	Minimum Phase-to-Earth clearance
3.3	11	220 mm	220 mm
6.6	11	220 mm	220 mm
11 and 15	22	330 mm	330 mm
22	33	440 mm	440 mm
33	33	440 mm	440 mm

Non-condenser type bushings shall be used; bushings shall be specified as per section 6.

The required clearances between the bushings and earth shall conform to 1 above. Notwithstanding, it is the responsibility of the supplier to ensure that adequate clearances are chosen such that at 1800m altitude no flashover will occur.

### 5.2.2 Primary Cable Box/Enclosure

The primary cable metal enclosed termination, if specified, shall be air filled and shall be positioned on the side of the transformer tank. It shall be a dust, vermin, weather-proof, lockable (top and bottom) enclosure (using a standard Eskom padlock) with a vertically hinged axis door with IP 55 rating. The door of the enclosure must allow access to the entire opening of the enclosure (same size as enclosure).

**ESKOM COPYRIGHT PROTECTED**

Power cables shall enter the enclosure from the bottom and must be mounted on a removable, undrilled, brass gland plate which shall be designed in such a way that, once removed, the entire bottom of the cable termination enclosure is open (i.e. the bottom of the cable termination enclosure shall form the gland plate). The plate shall be bolted to the enclosure by means of stainless steel bolts and nuts and its thickness shall not be less than 6 mm and be sealed by means of a 6 mm cork gasket.

The enclosure shall be provided with a corrosion resistant gauze covered drain/breathing hole of 15-25 mm diameter fitted at the lowest point (not side mounted) of the enclosure but not on the cable gland plate.

The primary cable enclosure and cables shall conform to the voltage and corresponding required insulation levels specified in the AB schedules in line with the requirements of Table 4.

The primary cable termination enclosure shall have one bushing per phase and shall be suitable for the termination of the type specified in SANS 876 (33kV and below will have Type 4), unless otherwise specified in the enquiry document. The minimum clearance between bushing centres (i.e. phase-to-phase and phase-to-ground) within the HV cable termination enclosure shall be suitable for the applicable voltage and insulation levels (as per A/B schedule and Table 4) and shall be maintained taking into account the lugs, flag orientation and fasteners required to connect the cable to the bushing. In addition, there must be sufficient space between the bottom of the flags and the gland plate to cater for cable termination.

A polypropylene cable support clamp shall be provided below the HV cable termination enclosure for supporting the HV cable. The clamp's diameter shall match the cable's outer diameter. The centre of the clamp shall be positioned to correspond with the centre of the cable entry hole in the gland plate.

The depth of the cable box (i.e. front to back) shall be at least 350 mm, providing sufficient space for cable installation and termination. See 2 and 3 below for typical 33 kV screened terminations.

An HV warning sign shall be fitted to the cover/lid of the primary cable termination enclosure as stated in Section 8.2.5 of this document.

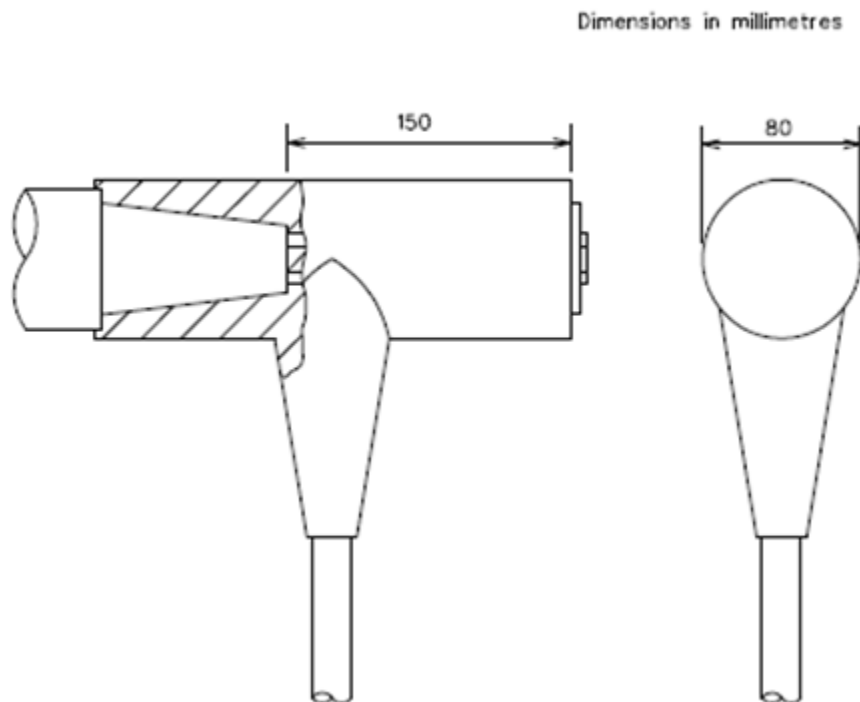

Figure 2: 33kV (screened separable) connector dimensions

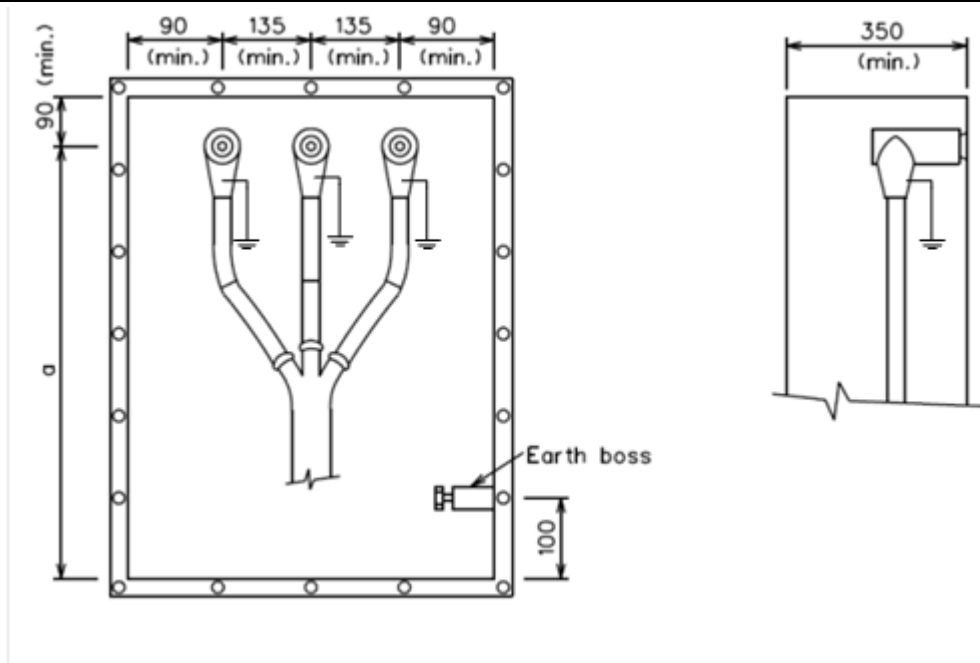

Figure 3: 33kV HV cable termination enclosure dimensions, 'a' in accordance with SANS 876

- Only trained and certified jointers to be used for all cable terminations and connections.

### 5.2.3 LV Cable Box

The transformer LV terminals, where applicable, shall be extended to a moulded-case air circuit-breaker (see section 5.2.4 below).

Bushings, lugs, terminations, conductors, circuit breakers shall be capable of handling continuous full load current as well as 130% overcurrent for 1 hour and 120% overcurrent for 2 hours.

The LV equipment shall be mounted in a dust, vermin, weather-proof, lockable (top and bottom) enclosure (using a standard Eskom padlock) with a vertically hinged axis door with IP 55 rating. The door of the enclosure must allow access to the entire opening of the enclosure (same size as enclosure). Enclosure shall be provided with a corrosion resistant gauze covered drain/breathing hole of 15-25 mm diameter fitted at the lowest point (not side mounted) of the enclosure but not on the cable gland plate.

The LV Power cables shall enter the enclosure from the bottom and mounted on a removable, undrilled, brass gland plate which shall cover an opening of not less than 300 mm x 150 mm. The plate shall be bolted to the enclosure by means of 6 x 8 mm stainless steel bolts and nuts. 6 to 9 below illustrate the correct positions of the cable entry points, showing the sequence for each additional cable. The plate thickness shall not be less than 6 mm and be sealed by means of a 6mm cork gasket. The circuit breaker shall be mounted on a back-plate. Sufficient space shall be allowed for the installation of an additional circuit breaker on the back-plate for all units. Where a second circuit breaker is required it shall be indicated on the A/B schedule or on the specific order.

The LV cable termination enclosure shall have one bushing per phase and shall be suitable for the termination of the type and number of cables specified in 2, unless otherwise specified in A/B schedule of the enquiry document. The minimum clearance (i.e. 60 mm between live metal phase-to-phase and phase-to-earth), indicated in 4 and 5 below shall be maintained taking into account the lugs, flag orientation (if applicable) and fasteners required to connect the cable to the bushing. In addition, there must be sufficient space between the bottom of the circuit breaker and the gland plate to cater for cable termination.

For LV cable termination enclosure not fitted with a moulded-case air circuit-breaker, the LV bushings shall be supplied with undrilled copper flags suitable for connection of the number of LV cables. Where more than two LV cable lugs are to be terminated per phase, they may be connected to either side of the flag. The current density of copper flags shall not exceed 2,0 A/mm<sup>2</sup> for rated currents up to and including 630 A and 1,6 A/mm<sup>2</sup> for rated currents greater than 630 A. Suitable set of screws, nuts, washers and spring washers shall be provided with copper flags.

**Table 2: Cable Sizes for secondary cable boxes**

Transformer Rating (kVA)	Size and Type of LV Cable
100	70 mm <sup>2</sup> Cu 4-core PVC/SWA/PVC
200	70 mm <sup>2</sup> Cu 4-core PVC/SWA/PVC
315	150 mm <sup>2</sup> Cu 4-core PVC/SWA/PVC
500	150 mm <sup>2</sup> Cu 4-core PVC/SWA/PVC
1000	500 mm <sup>2</sup> Cu 1-core PVC/SWA/PVC

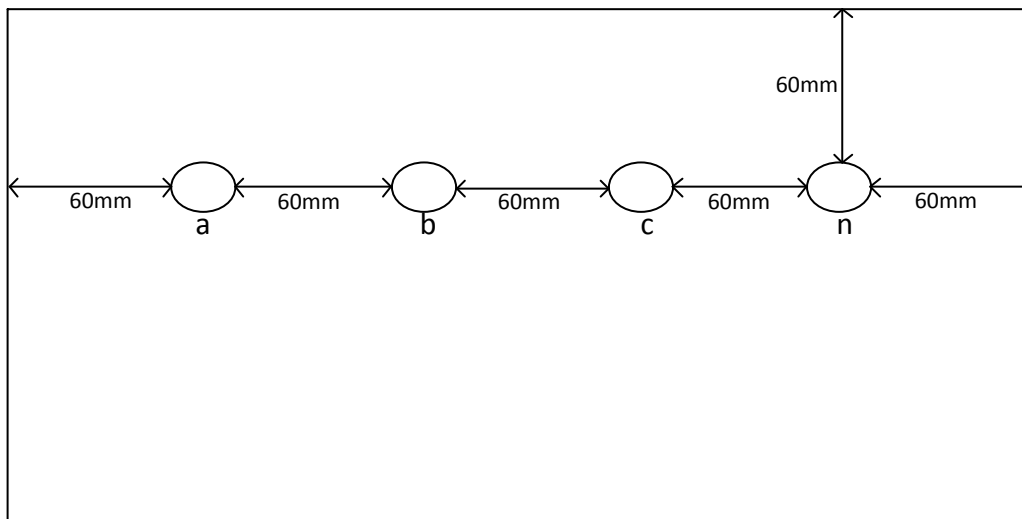

**Figure 4: Minimum clearances between cable terminals and enclosure in Secondary (LV) cable box**

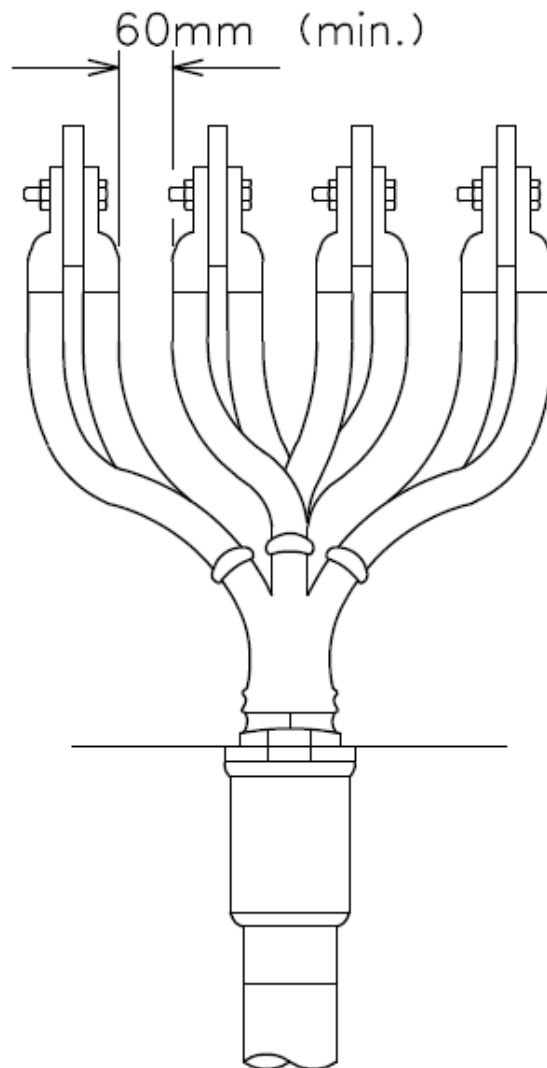

Figure 5: LV cable phase to phase clearance

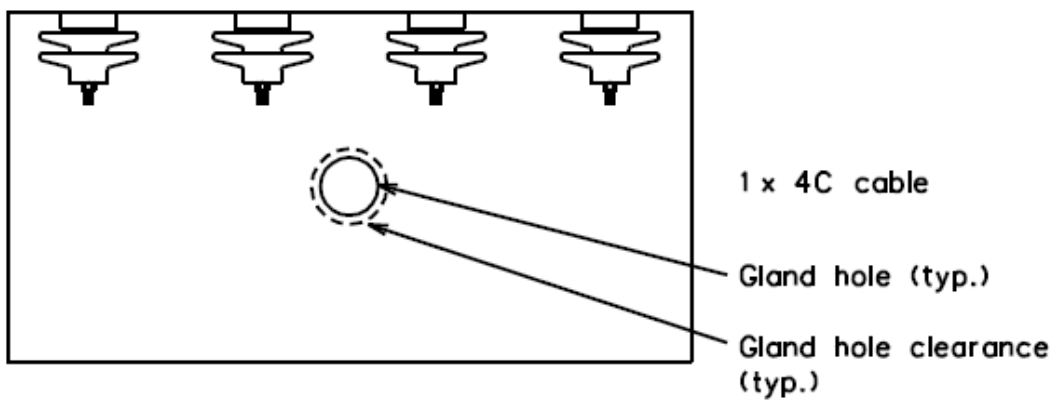

Figure 6: Gland plate hole positions, 1 cable

**ESKOM COPYRIGHT PROTECTED**

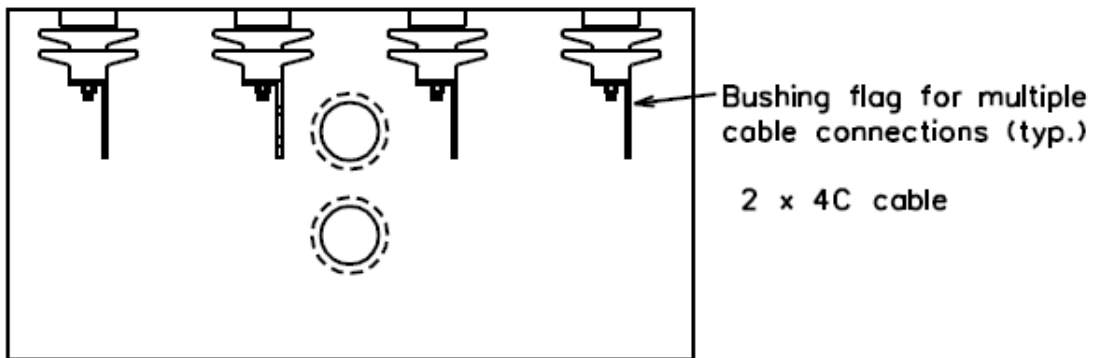

Figure 7: Gland plate hole positions, 2 cables

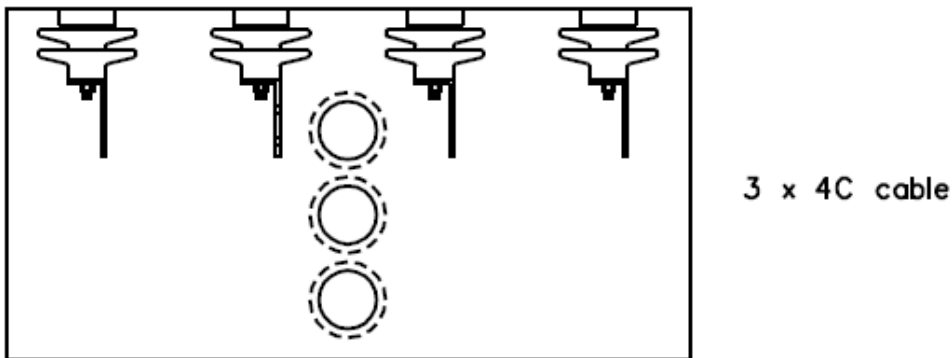

Figure 8: Gland plate hole positions, 3 cables

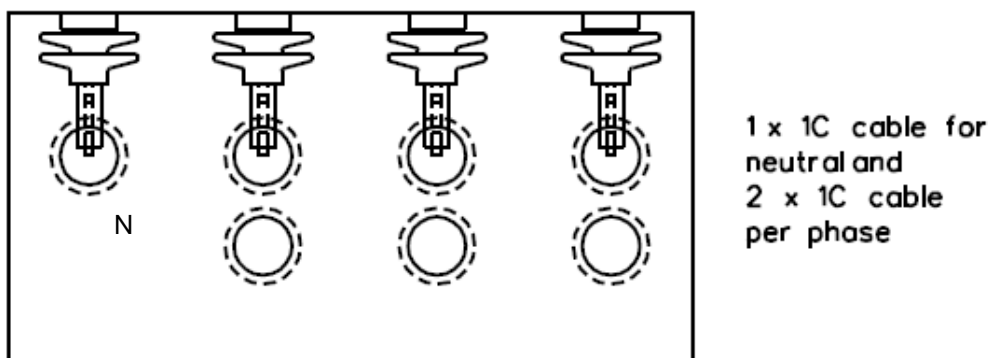

Figure 9: Gland plate hole positions, 6 cables

- Only trained and certified jointers to be used for all cable terminations and connections.

#### 5.2.4 Circuit breaker (LV)

The circuit breaker shall be equipped with trip and alarm contacts (which shall be rated for 220 V<sub>DC</sub> and 1 A continuous) which are unaffected by the manual opening of the circuit breaker. The circuit breaker shall be of adequate fault interrupting capacity, assuming the transformer impedance to be the only limiting factor.

**ESKOM COPYRIGHT PROTECTED**



The Moulded–Case Circuit Breaker (MCCB) shall:

- a) Allow for bolted connections on the transformer side
- b) Have a load capability inherently independent of ambient temperature or shall be fully ambient temperature compensated up to 80°C.
- c) Have all MCCB terminals and LV bushing terminals suitably shrouded to prevent inadvertent human contact.
- d) In all other respects comply with SABS 156.

## 6. Outdoor Bushings

Outdoor Bushing ratings (voltage levels) shall be as per 1 and as indicated in the A/B schedules.

The transformer HV terminals, mounted vertically on the tank cover, shall comprise of non-condenser solid outdoor type bushings with porcelain or composite insulation, typically silicon rubber sheds which are non-helical. These shall have plain, solid cylindrical copper terminals of 26 mm in diameter and 125 mm in length. Bushing insulation material must have passed a long term pollution ageing assessment (such as KIPTS or equivalent). The terminals shall be silver plated. Terminals shall be connected directly onto the bushing tie rod. Open tie rod sections with lock nuts are not acceptable. Terminals fitted with sleeves to increase the diameter will not be accepted. The bushing detail shall be specified in the A/B Schedule.

No arcing gaps are required.

The required clearances are as per table 1 above.

The minimum dry impulses withstand test voltage and the minimum 60 seconds power frequency wet withstand test voltage for the HV bushings shall conform to the levels specified in the A/B schedules and Section 7. The creepage distance for every voltage category shall be of heavy pollution type of 31mm/kV.

All bushings shall comply with the main requirements of the latest IEC 60137 and IEC 60815.

## 7. Insulation Levels

The auxiliary Transformer winding insulation levels shall be as specified in the corresponding Schedule A/B in line with 3 and 4 below, depending on whether or not the transformer in question shall be installed where it is exposed; that being the unit is exposed to the outside environment and connected to overhead power lines.

**Table 3: Insulation levels for the different typical voltage levels, in installations where the transformer is exposed (i.e. primary bushing used outdoors)**

System highest voltage - Um (kV rms)	System Nominal Voltage – Un (kV rms)	Lightning Impulse voltage withstand level at sea level (BIL) (kV peak)	60s power frequency voltage withstand level at sea level (kV 60s 50Hz)	
			Separate source	Induced
		<b>Line Terminal</b>		
0.4	0.38	30	8	2 * Un
0.44	0.4	30	8	2 * Un
3.6	3.3	75	22	2 * Un
7.2	6.6	95	28	2 * Un
12.0	11	150	50	2 * Un
16.5	15	150	50	2 * Un
24	22	200	70	2 * Un
36	33	200	70	2 * Un

**Table 4: Insulation levels for the different typical voltage levels, in installations where the transformer is not exposed (i.e. such as those connected to cable networks on the primary)**

System highest voltage - Um (kV rms)	System Nominal Voltage – Un (kV rms)	Lightning Impulse voltage withstand level at sea level (BIL) (kV peak)	60s power frequency voltage withstand level at sea level (kV 60s 50Hz)	
			Separate source	Induced
		Line Terminal		
0.4	0.38	30	8	2 * Un
0.44	0.4	30	8	2 * Un
3.6	3.3	60	16	2 * Un
7.2	6.6	75	22	2 * Un
12.0	11	95	28	2 * Un
16.5	15	150	50	2 * Un
24	22	200	70	2 * Un
36	33	200	70	2 * Un

## 8. Nameplate and Labeling Details

### 8.1 General

Rating and diagram plates shall comply with the all requirements of IEC 60076-1 as well as the requirements below.

### 8.2 Materials, Marking and Mounting

#### 8.2.1 Rating and diagram plates

Rating and diagram plates shall be of stainless steel (Grade 316) and not less than 1.2 mm in thickness.

The required information shall be engraved or chemically etched on the plate and filled with glossy black, baked stove enamel. Nameplate and layout diagrams shall be submitted to Eskom for approval.

The rating and diagram plates shall be mounted on a purpose made backing plate clearly visible from ground level by means of stainless steel bolts. Nameplates shall be elevated from the mounting bracket to prevent vibration and corrosion.

A permanent physical centre of gravity marking must appear on the tank at a suitable location to facilitate installation.

#### 8.2.2 General Labeling

All labelling and markings shall be permanently engraved labels. The colour of the labels shall be silver with black lettering. The labels shall be manufactured from UV stabilised PVC that is oil and heat resistant. Stainless steel (Grade 316) engraved labels are preferred.

Labels shall have a minimum thickness of 1.2 mm and not exceed 2 mm. The labels fixed on the equipment must be able to withstand at least 120°C when attached to the tank.

All labels to be permanently fixed to the transformer tank, sticker type or painted labels are not acceptable.

### **8.2.3 Terminal Labels**

Labels shall be provided on the main tank to indicate bushing positions. Terminal Labels shall be as per figure 1 and clearly visible from ground level. Terminal labels shall be embossed or engraved and must be permanently fixed to the tank and shall not become illegible during painting maintenance. Sticker type or painted labels are not acceptable.

### **8.2.4 De-Energized Tap Changer (DETC) Label**

A permanently engraved label with the words "WARNING DO NOT OPERATE WHEN ENERGISED" shall be provided below the de-energised tap changer operating handle. Label fixing shall neither penetrate the equipment housing nor constitute a potential source of corrosion. Labels shall be permanently attached.

### **8.2.5 Cable box labeling**

LV and MV cables boxes must have a warning sign in accordance with drawing D-DT-3202 shall be fitted to the cover/lid of the LV/MV cable termination enclosure. Labels shall be permanently attached.

## **9. Information to be displayed**

### **9.1 Rating plates**

- System voltages and related insulation levels
- KVA rating for each system voltage, if KVA rating changes at any tap position this must be indicated on the nameplate
- Cooling class
- Short-time fault current and time ratings
- Specification reference number
- Number of phases
- Vector group / connections
- Measured Percentage Impedance values at lowest, nominal and highest tap positions
- Zero sequence impedances in the case of three phase transformers
- Current transformer data detailed (if applicable)
- Year of manufacture
- Manufacturer Name
- Factory used
- Contact information for local technical support
- Serial Number
- Statement that the transformer will withstand full vacuum at sea level shall appear
- Oil quantity (total) - in litres
- Weight of active part - in kilograms
- Total weight - in kilograms
- Oil level reference graph / table
- Graphical display of winding and terminal arrangement
- Gravitational acceleration forces limits in all directions i.e. X,Y and Z

**ESKOM COPYRIGHT PROTECTED**

- Power frequency TOV withstand and duration
- Oil supplier, oil type and inhibitor levels

## 10. Core Design Requirements

The manufacturer shall have magnetic field plotting capability and other data to determine the losses and temperatures resulting from the leakage flux. An analysis shall be made to determine the temperatures of components subject to the leakage fields that can produce excessive heating. This will include but will not be limited to tie plates, outer core laminations, tank walls in the vicinity of high current leads, structural parts in the vicinity of high current bushings. This will be a design review item.

### 10.1 Material

The core shall be manufactured of high permeability; non-ageing cold rolled grain oriented steel sheet laminations having smooth, insulated surfaces. The maximum allowable size of burrs on the slit or cut edge of the electromagnetic steel shall not be capable of causing damage to the insulation between sheets and shall be less than 0.02mm. For all transformers core shall be of mitred construction. The core sheets stacking and all the insulation designed in a way that no detrimental changes in physical or electrical properties will occur during the lifetime.

### 10.2 Design

For rated voltage and rated frequency, the maximum core flux density in the limbs and in the yokes shall not exceed 1.72 Tesla. The maximum temperature rise of the core surface in contact with oil and cellulose insulation above ambient temperature of 30°C should not exceed 75°C for all possible rated in service conditions. The core surface must be limited to the temperature capability of the material in contact with the core using the average ambient specified. The material used in core cooling ducts, and between the core and frames, and between the core and the tie plates shall have a continuous temperature rating of 150°C minimum.

### 10.3 Core Earthing

The main magnetic core shall be directly grounded internally at one point. No core earthing connection shall have a cross-sectional area smaller than 80 mm<sup>2</sup>, with the exception of the connections inserted between laminations which may be reduced to a cross-sectional area of 20 mm<sup>2</sup>, where they are clamped between the laminations.

For the core clamping no bolts through the limbs and yokes shall be used. The limbs should be fastened by non-metallic bands/belts. Non continuous steel straps or rods used around the yokes must be insulated from the yokes to prevent shorts to the core and circulating currents. The pressure of the yokes shall be adequate to prevent movement of the lamination during shipping accelerations.

### 10.4 Core and Supporting Structure Temperatures

The hottest rise above ambient of metal parts in contact with oil shall not exceed 75°C under the most extreme operating circumstance. Also, the most onerous temperature of any part of the core and its supporting structure in contact with insulation or other thermally non-conducting material should not exceed the safe operating temperature of that material. Adequate safety margins should be included when determining these criteria.

### 10.5 Electrical Continuity

Where the core laminations are divided into sections by insulating barriers or cooling ducts parallel to the plane of the laminations, tinned copper bridging strips shall be inserted to maintain electrical continuity between sections.

## **10.6 Insulation of the Core**

The insulation between the core and the clamping structure, and/or bands and buckles, shall withstand a test voltage of 1000V<sub>DC</sub> for 60 seconds. Designs requiring through core bolts are not allowed by Eskom.

## **10.7 Earthing of the Core Clamping Structure**

The bottom core clamping structure shall be bonded with the top core clamping structure through the tie bar, or by means of a flexible connection. The left and right sides of the clamping structure shall also be bonded with each other by means of a flexible connection. All flexible connections must be easily identified and accessible for investigation purposes. These bondings shall not cause loops for circulating currents.

## **10.8 Lock-nuts/ locking plates**

The core and core clamping structure shall be of adequate strength to withstand, without damage, the stresses to which it may be subjected during handling, transportation, installation and service. All nuts shall be effectively locked by means of locking plates or standard machined lock nuts. Fasteners with sharp edges in the vicinity of high voltage stresses are not acceptable and must be covered with corona or stress shields. If the locking plates have been locked and opened, they must be replaced. Fasteners of insulating material shall be fixed by glueing or other approved means indicated in writing from Eskom.

## **10.9 Lifting Facilities for Active Part**

Lifting lugs or other means shall be provided on the top clamping structure for conveniently lifting the core and windings, and when lifting, no undue stress shall be imposed on any core, insulation or on the tank cover plate.

# **11. Winding Design Requirements**

## **11.1 Material**

All windings shall be constructed with Copper or Aluminium foil or Copper conductors. Aluminium conductors may be considered provided a type test (including short circuit) was performed or is to be performed (at no cost to Eskom) on a similar design transformer with Aluminium conductors. A loss comparison between copper and aluminium conductors should also be submitted in this case. Winding Insulation shall consist of Kraft Paper or enamel. If enamel is used it must be grade 3 or better. The insulation material type and data shall be declared in the A/B schedules and shall be clarified at design review stage.

## **11.2 Design**

Core form windings shall be of circular concentric type. No winding joints are permitted.

The winding material and design shall be confirmed and approved per design on a case by case basis between the manufacturer and Eskom, in line with the data to be provided by the manufacturer in the A/B design schedules. See section 35 concerning the Design Review meeting.

## **11.3 Hot-spot Calculations**

The calculated hot spot shall be based on the maximum calculated localised losses in the windings, the insulation on the points with maximum losses, and the oil rise in the windings. If the designer is not able to determine the oil rise in the windings, an added 5°K will be made at the design review to allow for the difference between the oil rise in the windings and bulk top oil in the tank.

The maximum hot spot in leads shall not be more than 1°K above the maximum calculated hot spot in the windings.

## **11.4 Insulation Design**

The highest inter layer stress, based on the DIL (Design Insulation Level) in both the tapping and non-tap part of the winding must be < 5 kV/mm. Insulation design elements shall be clarified at Design Review stage.

## **11.5 Internal Connections**

Copper conductors shall be used throughout for leads.

There shall be no soldered joints or terminals in the transformer. All internal lead connections shall be brazed, welded, or compression type. If compression type is used, then the method employed must be approved by Eskom.

No joints are permitted internal to the windings.

Electrical connection from the winding to the line terminal of the bushing shall be by means of a flexible lead.

## **11.6 Short-circuit capability**

The transformer short circuit capability shall comply with the requirements of IEC 60076-5.

The manufacturer shall submit with its tender a complete listing of relevant similar transformers that have been short circuit tested and manufactured at the facility where the tendered transformers will be manufactured, the list to include the outcome of the short circuit test, the facility where tested and the date of the test. A typical test certificate for a unit similar to the unit to be purchased must be supplied. Upon request a complete description of the transformer characteristics shall be provided. Calculations for short circuit withstand capability shall be submitted with the tender.

Special attention has to be paid to the effects of axial short circuit forces as a result of:

- Shifted ampere-turn gravity along the circumference of pitched windings, which are extremely exposed, to the radial component of the stray flux.
- End thrust of windings due to unbalanced ampere-turn gravity
- Misalignment of magnetic centres of gravity of concentric windings

The copper yield strength shall be at least 50% higher than the axial bending stress on the conductors at the axial end of the windings.

Winding Designs to include the following:

- Where windings are radially inward compressed during short circuits, these windings must be constructed with at least 50% factor of safety (50% higher than radial compressive forces).
- Extreme pitched windings must be avoided or arranged in an area of low radial stray flux components.
- The free buckling forces on the winding must not exceed 60% of the yield strength of the copper and bending forces must not exceed 80% of the yield strength of the copper.
- The short circuit forces must withstand 1.1 pu voltage and be based on using only the transformer impedance and no system impedance in the circuit.
- Sufficient axial winding clamping shall be provided over the full radial axis of the winding, top and bottom, to ensure no axial movement under any of the service conditions. The winding clamping material used shall have no effect on the insulation level required. The winding radial strength shall be sufficient to withstand the forces from all possible service conditions.

## **11.7 Sizing and compression of windings**

All windings shall be sized using a maximum tolerance of -0 + 2 mm.

## 12. De-energized Tap changers Requirements (DETC)

### 12.1 General

De-energised tap changers shall be direct or gear driven type with a lockable handle that also indicates the tap position. Mechanical stoppers shall be provided at upper and lower tapping positions.

### 12.2 Tapping ranges

A high voltage De-Energized lockable tapping switch (DETC) shall be provided and shall have tappings corresponding to 95%, 97.5 %, 100%, 102.5% and 105% of the rated primary voltage. The tapping range shall be stated on the rating plate. The tappings are mainly intended to compensate for primary voltage requirements. The 400 V secondary voltage shall correspond to 100% tap position for primary voltage.

## 13. Factory Testing

The testing shall comply with the latest IEC standards and shall include the following tests in 5 and acceptance criteria shall be in accordance with the suite of the latest version of the IEC 60076 standards. Notwithstanding, prescriptions to test levels and temperatures over and above IEC requirements presented in this specification and/or accompanying schedules shall take preference.

**Table 5: Tests to be performed**

<b>Main test required as per IEC:</b>	
<b>Low Voltage tests (Winding ratio, resistance, vector group, magnetisation, insulation test) as per IEC 60076-1</b>	Routine
<b>load and no load losses</b>	Routine
<b>Temperature rise test (Overload of 130% for 1 hour or 120% for 2 hours)</b>	Type, (only on the first unit of each unique design)
<b>Short-circuit withstand tests</b>	Type, Calculation for the short circuit withstand capability should be submitted with the tender plus a test report of particular unit as per A/B schedule or a similar unit.
<b>Lightning impulse test (both full wave and chopped wave)</b>	Type (chopped wave) Routine (full wave)
<b>Short Duration Induced over voltage test without PD</b>	Routine
<b>Separate Source ( Applied voltage test)</b>	Routine
<b>Acoustic noise level measurement</b>	Type
<b>Dielectric loss angle test and capacitance of winding. (Eskom approved instrument)</b>	Routine
<b>SFRA – Fully assembled filled with oil. (Eskom approved instrument) Must be performed with the transformer at tap position which includes entire winding in the test circuit</b>	Routine
<b>Dissolved Gas in oil analysis, dielectric strength and water content tests.</b>	Routine
<b>Appearance, construction and dimension check</b>	Routine
<b>Functional Test on transformer auxiliary components</b>	Routine

**ESKOM COPYRIGHT PROTECTED**

### 13.1 Dielectric test levels

The levels for testing for each transformer shall be as per each unit specific A/B schedule in line with the levels prescribed in 3 and 4. Note for conflicting test levels between a specific A/B schedule and this specification the levels on the schedules take precedence; provided they exceed the insulation requirements of this specification.

### 13.2 Typical Type Test Reports

It is required that with the tender returnables a full detailed typical type test report(s) be submitted for typical unit sizes.

### 13.3 Typical Test Plan

It is required that a detailed typical test plan be submitted with the tender.

### 13.4 Temperature Rise

Temperature rise limits must be as below or as specified in Schedule A/B. The calculation and measurement of the limits must be performed in accordance with IEC 60076-2 standard. It has to be considered that the annual average rated ambient temperature is 25°C. During the temperature rise test DGA oil samples must be taken before and after the test and the measured increases must be below the permissible limits in 6.

### 13.5 Winding Rise

The average winding rise above ambient at nameplate MVA rating shall not exceed 60°K for oil natural flow through the windings. This shall be confirmed during the temperature rise test by the calculation of the winding rise from the top oil rise based on measurement of winding resistance in line with IEC 60076-2.

### 13.6 Winding Hottest Spot Temperature Rise

The winding hot spot temperature rises above ambient at nameplate kVA rating shall not exceed 73°K.

### 13.7 Top Oil Rise

The top oil temperature rise on full load above ambient shall not exceed 55°K.

### 13.8 Temperature Rise of Metallic Parts at Rated MVA

The highest temperature rise above ambient of metallic parts in contact with cellulose material outside the winding block shall not exceed 73°K. The rise above ambient of other metallic parts in contact with oil and paper insulation including core and tank shall not exceed 80°K under any operating conditions (i.e. overload conditions during overload test). This shall be measured during the temperature rise test during overload using a thermal camera scanning the outer parts of the tank and bushing turrets.

**Table 6: Permissible increase of gas in oil during temperature rise testing**

Gas	Name	Permissible increase (ppm)
CH4	Methane	2
C2H6	Ethane	2
C2H4	Ethylene	1
C2H2	Acetylene	None detectable
H2	Hydrogen	10
CO	Carbon monoxide	20
CO2	Carbon dioxide	200



## **13.9 Sound Level**

The maximum noise level at full load operation in service shall be as specified in the A/B schedule of the specification, in line with Table 6 of SANS 780.

## **14. Inspection at the Manufactures Factory**

The manufacturer shall notify Eskom at least 8 weeks (if international supplier) or 3 weeks' notice (if local supplier), prior to the following in line with an agreed inspection and test plan:

- Coil winding sizing inspection
- Core stacking completion inspection
- Beginning of active part assembly before vapour phase
- Completion of active part assembly before tanking
- Factory Acceptance Testing
- Shipment

Eskom reserves the right to inspect the transformer at any point during construction as per agreed Inspection and Test Plan and to witness the tests. The manufacturing bar chart shall provide the above dates within one month after the order is placed and shall be updated monthly. Signing off of these intervention points by Eskom does not relieve the OEM from the requirements of this specification, guarantees and warranties.

## **15. Insulating Oils**

### **15.1 General**

The transformer oil shall be virgin oil and shall comply with Eskom specification 240-75661431 Table 5 if inhibited and table 6 if uninhibited (shall be specified on A/B schedules) and must be approved by Eskom prior to filling and comply with ESP 32-406 table 12 after filling. The supplier must provide test results and certificates showing that the oil complies with the mentioned standard. Oil must be declared in the A/B Schedule. OEM to ensure oil used is approved by Eskom and to carry the responsibility of the oil during the guarantee period.

### **15.2 Oil-filling and impregnation under vacuum**

Comply with 240-56062726 as a minimum requirement.

## **16. Main Tank Construction**

### **16.1 General**

The tank shall be made of mild steel.

The tank and fittings shall be able to withstand full vacuum at sea level.

The top cover shall be bolted and gasketed to the main tank.

All inspection covers shall be bolted and gasketed.

All internal connections shall be designed so that bushings can be removed or installed without having to remove the top cover. Replacement of bushings shall be possible by performing a partial drain without exposing the paper/ winding block.

## 16.2 Materials and Welding

Unless otherwise approved metal plate, bar and sections for fabrication shall comply with EN 10025. Welding shall comply with EN 1011. Welds exposed to the atmosphere shall be continuous. Dye-penetrant tests shall be carried out on all welds and joints. All edges shall be rounded to ensure no sharp corners that will influence the paint quality.

## 16.3 Corrosion Protection and Paint Finish

Corrosion Protection shall comply with 240-56030674.

## 16.4 Tank Shape

The shape of the transformer tank and fittings, including the under base shall be such that no water can be retained at any point on their external surfaces. The lid shall be shaped to ensure that all free gasses generated inside the transformer escape to the conservator via the gas and oil actuated relay.

## 16.5 Cooling Corrugations

Corrugated tanks are not acceptable.

## 16.6 Guides for Core and Winding Assembly

Guides shall be provided inside the transformer tank to correctly locate the core and winding assembly in the tank.

## 16.7 Fasteners

Only stainless steel fasteners (bolts, nuts, studs, washers & screws) to be used for all assembly points. In order to prevent sizing of different grades of stainless steel 316 bolts/studs and 304 nuts and washers shall be used.

Other than for flange-flange connections only studs with nuts and lock washers shall be used on inspection covers, bushings turrets, bushing flanges, etc. Use of bolts in these areas is not acceptable.

## 16.8 Tank Strength and Oil Tightness

### 16.8.1 Rigidity

Transformer tanks and their associated components shall have adequate mechanical strength and rigidity to permit the complete transformer, filled with oil, to be lifted, jacked and hauled in any direction, and to be transported without structural damage or impairment of the oil tightness of the transformer, and without the necessity for the special positioning of sliding rails in relation to the tank. Tank stiffeners shall not cover welded seams, to enable the repair of possible oil leaks.

### 16.8.2 Internal pressure and vacuum

Transformer tanks, complete with all fittings and attachments normally in contact with the transformer oil, and filled with oil of the specified viscosity, shall withstand the pressure and the leakage tests. When empty of oil they shall withstand the full vacuum test.

### 16.8.3 Tank base construction

The transformer shall have a flat tank base of at least 10 mm thickness. Irrespective of the base design used, it shall provide adequate mechanical strength to support the active part during transportation and installation activities.

Special care shall be taken to restore the condition of the paint under the base of the transformer when it is being put to final position of operation and shall comply with 240-56030674.

**ESKOM COPYRIGHT PROTECTED**

#### **16.8.4 Partial drain indication level on tank**

A permanent (not effected by painting) indication must be present on the exterior of the tank indicating the oil level for partial draining whereby the active part shall not be exposed.

#### **16.9 Lifting Lugs**

Four symmetrically placed lifting lugs shall be provided so that it will be possible to lift the complete transformer when filled with oil without structural damage to any part of the transformer. The factor of safety at any one point shall not be less than 2.

The lifting lugs shall be so arranged and located as to be accessible for use when the transformer is loaded on the transport vehicle, and so as not to cause fouling of any of the transformer fittings and accessories.

#### **16.10 Hand holes**

Hand holes shall be provided to facilitate the removal and installation of bushings.

#### **16.11 Gaskets**

All oil to air and gas to air joints shall be sealed by means of gaskets or O-rings. Gaskets and O-rings shall be oil and heat resistant. Flanges shall be treated to withstand corrosion effects on the sealing surfaces.

#### **16.12 Bleeding Points**

Where bleeding points are provided it shall only be stainless steel type DIN 42 558. Seals shall be UV, heat and oil resistant.

#### **16.13 Earthing Pads and Cleats**

Stainless steel earth pads shall be provided for connecting the transformer main tank to the substation earth mat. At least two earth pads shall be provided on one of the sides of the main tank not higher than 100 mm from the tank base.

The pads shall be secured to the tank by means of continuous welding around the perimeter. Cleats shall be provided on the tank wall for securing 50 mm x 3 mm copper straps.

### **17. Conservator Tank Construction**

#### **17.1 Capacity**

The capacity of the oil conservator shall be such that the oil level will not fall below the top of the feed pipe to the transformer for a top oil temperature of  $-10\text{ }^{\circ}\text{C}$  and shall as a minimum not overflow for a top oil temperature of  $115\text{ }^{\circ}\text{C}$ . Note the requirements for sump in Section 17.4.

#### **17.2 Strength**

The conservator shall be designed and tested to meet the full vacuum requirements.

#### **17.3 Mounting**

Oil conservators shall be mounted to the transformer tank. Tank mounted conservators shall be bolted on brackets to facilitate the complete removal of the conservator for whatever purpose. The oil conservator shall fall in the direction of its main compartment drain valve by not less than 10 mm over the length of the conservator. Four x 5 mm thick stainless steel (Grade 304) spacers shall be welded to the fixing points on the conservator base stand. Corresponding stainless steel spacers shall be welded to the conservator support structure on the transformer.

The oil conservator shall be mounted off one end of the transformer unit, transversely to its major axis. A 15 mm brass drain valve shall be provided at the base of the conservator tank. The valve opening shall be sealed by means of a threaded plug. The conservator shall not contain pockets which are un-drained by the drain valve.

## **17.4 Sump**

The connection pipe to the transformer shall be so arranged that a level of oil of not less than 10 % of the internal vertical dimension of the conservator with a minimum of 25 mm remains in the conservator after it has been drained to the transformer.

## **17.5 Removable Covers**

The conservator tank end plate on the side where the oil level indicator is mounted shall be bolted and gasketed type. No opening shall be provided on top of the conservator tank.

## **17.6 Pipework Connections**

The feed pipe to the transformer tank shall enter the transformer tank at its highest point and shall be straight for a distance not less than five times its internal diameter on the transformer side of the Buchholz relay, and straight for not less than three times that diameter on the conservator side of the relay. This pipe shall rise toward the oil conservator, through the relay, at an angle of not less than 2 degrees and not more than 7 degrees: whilst complying with the recommended (by OEM of Buchholz relay) angles of operation of the Buchholz in question. Auxiliary transformers shall have a feed pipe diameter corresponding to the oil volume as in the Buchholz spec 240-56063908. Header pipes shall be connected to the final rising pipe to the Buchholz relay as nearly as possible in an axial direction and preferably not less than five pipe diameters from the relay, on the transformer side of the relay. Pipework bends and elbows should not be 90 degree and should have a suitable bending radius.

All pipe work shall be effectively secured by means of mechanical clamping devices and support structures. Only U-bolts or bolted flags shall be used to secure pipework. Pipework shall not be in contact with the main tank or any other position, except for at the clamping points.

## **18. Cooling**

### **18.1 General**

Temperature limits as specified in IEC 60076-2. Unless otherwise specified differently in the A/B Schedules, the weighted annual average ambient temperature of 25°C has to be taken into account.

With reference to 25°C ambient temperature the temperature rise specified in IEC has to be reduced by 5°C.

### **18.2 Cooling Systems**

The cooling system shall be ONAN and the cooling radiators shall be welded to the main tank.

## **19. Valves**

All valves shall be manufactured from corrosion resistant material.

Valves, flanges and flange facings shall comply with the relevant requirements of this specification. Bottom positioned horizontally fitted valves shall be fitted with the handle facing upwards.

The valves shall be permanently sealed by means of a blank, bolted and gasketed cover.

## **19.1 Drain Valve**

A drain valve shall be provided at the lowest point on the main tank. The valve shall be of the gate valve type, double flanged, with a nominal bore of 25mm and manufactured of brass, these shall be painted in accordance with 240-56030674. The valve shall be provided with a mechanical locking mechanism to secure valve in the closed position. The valve shall be fitted with a blanking plate and gasket on the outlet.

## **19.2 Conservator isolating and drain Valve**

A double-flanged gate or butterfly valve of same diameter as the pipe to the main tank shall be provided below the conservator tank to isolate oil supply to the transformer main tank.

A 25 mm gate valve shall be provided to fully drain the conservator tank. This valve shall be mounted at the lowest point on the conservator tank, and the open end shall be sealed by means of a brass nipple.

## **20. Oil Temperature Indicator**

Oil temperature indicator shall comply with 240-56063843, but without remote temperature monitoring facility and single contacts for each alarm/trip.

## **21. Oil Level Indicator**

Oil level indicators must comply with 240-56356191 but with single contacts for each alarm/trip.

## **22. Oil Sample Points**

A single oil sample point shall be provided for oil sampling. The sample pipe shall be connected to the top of the Buchholz relay and routed to ground level. The sample point must be clearly labelled "Routine Oil Sampling Point" in accordance with section 8.2.2.

The sample point shall be easily accessible from ground level, approximately 200 mm from the base of the transformer.

10 mm (outer diameter, 7mm inner diameter) copper tubing, sufficiently long to allow the sample point to be approximately 200mm from the base of the transformer from the Buchholz, with SAE 45 flared connections shall be used as sample pipes. Only corrosion resistant needle valves shall be used as sample valves. The open end of the valve shall be sealed by means of a threaded plug. Alternatives shall be considered with prior evaluation and approval by Eskom.

## **23. Gas and Oil Actuated Relay (Buchholz)**

Buchholz relays must comply with 240-56063908 but with single contacts for each alarm/trip.

## **24. Dehydrating Breather**

Breathers shall comply with 240-56062529.

## **25. Alarm and Trip Termination**

All transformers shall be provided with the following alarm contacts:

### **25.1 Alarm Signalling**

High Oil Temperature (Top Oil)

Low Oil Level: (Main Conservator Tank)

Gas actuated relay (Buchholz) alarm

LV Circuit breaker trip alarm

**ESKOM COPYRIGHT PROTECTED**

## **25.2 Trip Signalling**

High Oil Temperature (Top Oil)

Gas actuated relay (Buchholz) trip - gas and surge

## **26. Current Transformers**

Current Transformers are not normally required for auxiliary transformers. However, if they are required it shall be specified on the A/B schedules and enquiry document and the specifications of the CT shall conform to the schedules. In addition the particulars and placement would be confirmed at design review stage.

## **27. Shipment Preparation**

Eskom shall be notified by telephone and e-mail two weeks before the date the transformer is planned to be shipped stating the mode of transport, route, and estimated date of arrival.

## **28. Main Tank and Accessories**

The transformer shall be shipped fully assembled and filled with oil. The breather pipe must be capped.

## **29. Impact indicator**

Accelerometers shall be attached to each transformer for the duration of the transport process. The accelerometers shall give indication of the acceleration of the transformer in three directions i.e X,Y and Z and of which the main direction must be in the direction of transport.

The manufacturer of the transformer shall specify the maximum gravitational forces that the transformer is designed to withstand in all directions during the design review meeting. These limits shall be recorded on the nameplate and documented on the manuals.

The devices shall remain fitted to the transformer until final positioning.

## **30. Transport**

### **30.1 General Conditions**

The transformer shall be shipped fully assembled and filled with oil. The breather pipe must be capped.

It shall be the contractor's responsibility to make all arrangements for transport with the appropriate authorities. Eskom will only accept delivery from the contractor on site. It shall be the contractor's responsibility to co-ordinate the arrangements for all stages of the transport of the transformer from the manufacturer's works to site, including trans-shipping where necessary. Where off-loading is required, all apparatus, materials and packages shall be addressed to the contractor, who shall take delivery of the same at site.

### **30.2 Sea Transport**

The contractor shall make the necessary arrangements for suitable slings or lifting tackle to be available for off-loading at the quay-side and may make use of the equipment provided under the contract, on the condition that it is handed over to Eskom in good order.

### **30.3 Road Transport**

Where and if necessary, transport arrangements shall include any necessary extensions and/or improvements to road routes, bridges, and civil works, and also the assurance that any abnormal loads comprising the transformers, their transporters, ancillary apparatus and plant and equipment required for erection shall pass without obstruction throughout the selected route.

## 31. Installation and Erection

### 31.1 General

Erection shall include off-loading, installation, and testing of the transformer, as agreed by the applicable Scope Of Work (SOW) and Works report at that time.

All equipment provided for erection shall be removed from site when erection is completed and the site cleaned of any debris and oil spillage.

### 31.2 Foundation Tolerances and Transformer Layout Details

Foundation tolerances and layout details shall be submitted for prior approval by Eskom standard plinth sizes and standard 25 MPa rating.

### 31.3 Site Installation

Site installation shall be performed by the OEM or an Eskom approved sub-contractor.

All installation projects shall comply with the OHS Act No. 83 of 1993 and the construction regulations 32-136.

Before commencement of site / store installation a Scope of Work shall be compiled and agreed upon between the OEM and the purchaser. Compiling of the SOW shall be the responsibility of the contractor. This must include installation of the breather.

### 31.4 Functional Tests

- All valves in service position.
- Functional test for all alarm and tripping contacts.

### 31.5 Electrical Tests, Meeting Requirements of IEC 60076

- All voltage ratios on all phases
- Impedance test
- Vector group
- Three-phase 380 V magnetising currents
- Winding insulation test
- Control/power cabling insulation (minimum 1 kV)
- Zero sequence impedance
- SFRA
- Winding Tan Delta test

## 32. Auxiliary Supplies, Terminal Boxes, Wiring and Cabling

### 32.1 Supply Voltage

The auxiliary power supply will be rated at 400/230 Vac, three phase, 4-wire, 50 Hz. The unearthed DC supply will be 110 V or 220 V and can only be clarified per site and per order Notwithstanding all auxiliary contacts on the MCCB and transformer auxiliary shall be rated 220 V<sub>DC</sub> @ 1 A this allows them to operate at both 110 V<sub>DC</sub> and 220 V<sub>DC</sub>.

## **32.2 Terminal Boxes**

Terminal boxes shall be mounted on the transformer main tank. It shall be mounted in a position that it can remain fitted to the transformer tank during transport and installation. Terminal boxes shall be vermin-, dust- and weather-proof (IP 55 Rating) and shall be provided with easily removable covers fixed by not more than two screws.

Covers for terminal boxes shall be hinged in a vertical plane.

## **32.3 Spare terminals**

Each terminal box shall be provided with not less than 10% spare terminals with a minimum number of 6, unless otherwise agreed.

## **32.4 Incoming auxiliary circuits**

To prevent entry of water, the auxiliary wiring from the gas- and oil-actuated relay, current transformers and other auxiliary apparatus, shall be arranged for side or bottom entry into the marshalling or terminal box. If bottom entry is adopted, the gland plate used shall be independent of that provided for the Purchaser's outgoing cables. If cables enter the terminal boxes or marshalling kiosk from the side, drip-loops shall be provided to prevent water from entering the cable gland.

## **32.5 Provision for outgoing cables**

The terminal box shall be provided with a separate, removable, undrilled plate to take the Purchaser's cable glands, mounted at least 100 mm below the bottom of the terminal blocks, or other equipment, in such a manner as to facilitate the entry of the Purchaser's cables.

The gauze covered drain and vent hole may be fitted to his gland plate.

## **32.6 Cabling and Wiring**

Only UV stable, heat and oil resistant PVC SWA (Steel Wire Armouring) cable shall be used on transformers. Only corrosion resistant cable glands for armoured cables shall be used. Plastic compression type cable glands shall not be used on armoured cables. Heat, oil and UV resistant cable shrouds shall be fitted to all cable glands.

All cable terminations shall be provided with cable numbers fitted to the cables on both ends. Only permanently engraved, non-corrodible, UV, oil and heat resistant material shall be used for cable numbering. These labels shall be permanently fixed to the cable ends just before the glands on the outside of the terminal box.

## **32.7 Insulation**

Wiring insulation shall be oil- and moisture proof, and, where affected by temperatures above that of the ambient air, shall have thermal characteristics at least equal to class 'A' of IEC 60085 .

## **32.8 Insulation test voltage**

All auxiliary circuits shall withstand a test voltage of 2 kV r.m.s. to earth and to all other circuits.

## **32.9 Type of conductor**

All secondary wiring used on the transformer for current transformer secondary and other auxiliary equipment shall have a minimum cross-section of 2.5 mm<sup>2</sup> , and shall be limited to 30 strands per cable, flexible, 660/1000 V grade wire in accordance with SABS 1507 or if Eskom approved.

As far possible only cables with the correct number of strands shall be used. Where this is not possible the free stands shall not be cut, but effectively earthed on one side of the cable.



### **32.10 Supporting and securing of cables**

All cables shall present a neat appearance and shall be supported on cable rails elevated 20 – 30 mm from the tank surface. The rails shall be welded to the transformer tank surface. Similar rails shall be provided to route and secure cables to auxiliary components, i.e. oil level indicators, Buchholz relays, cooling fans, etc.

Cables shall be secured to cable rails by means of stainless steel strapping with a minimum width of 6 mm and not exceeding 10 mm.

Routing of cables shall be done to eliminate the cable from touching sharp edges on the transformer tank structure.

### **32.11 Identification of wiring**

All equipment boundary/interface terminals and the equipment wires connected to those terminals shall have a unique wire/terminal number in accordance with the manufacturer's drawings, approved by Eskom. The wires shall be marked with black letters impressed on a white background or black letters on a yellow background providing that the colour selected is consistent throughout the panel and/or suite of panels and is to Eskom's approval.

For heavy conductors and very light wiring (telephone type) where the preferred type of marking ferrules is not available, other methods may be approved.

Ferrules shall be arranged to read upright on cable terminal strips and to read from terminal to insulation in the case of relay apparatus and instrument connections.

### **32.12 Identification of fuses**

All fuses shall be labelled indicating the rating and circuit.

### **32.13 Identification of equipment**

All equipment identification labels in terminal boxes and control cubicles shall be fixed on permanent surfaces next to the equipment (above, underneath or next to) and not on removable covers or on the equipment itself.

## **33. Secondary Terminations**

### **33.1 General**

All terminals for connection to external circuits shall be subject to the Purchaser's approval. Not more than two conductors shall be connected to any side of a terminal, so that the size of all terminals is suitable for the termination of two external cables of 4 mm<sup>2</sup>, each.

All terminals except those with solder lugs shall be suitable for use with crimped or compression type terminations. Spare cable cores shall be grouped and earthed at one end of the cable. Cutting of spare cable cores is not acceptable.

### **33.2 Mounting of terminal blocks**

Rail mounted terminal blocks shall comply with DIN 46227 parts 1, 2 and 3 .

The units shall be spring retained on the assembly rail and when mounted and wired as in service, shall be close fitted to avoid the accumulation of foreign matter between adjacent units. End barriers or shields shall be provided for open sided patterns.

It shall be possible to replace any unit in an assembly without dismantling adjacent units; it is permissible however to loosen any clamping device. Screw retention of any component from the rear of the mounting rail is not acceptable.

### 33.3 Spring loaded terminal blocks

A rail mounted screw clamp/spring loaded insertion type terminal block suitable for the reception of hooked blade type wiring lugs shall be provided as shown in 10.

The terminal blocks shall be of the type which compresses the terminations between two plates by means of terminal screws. Terminals shall also be spring loaded such that the action of the spring is independent of the action of the terminal screw.

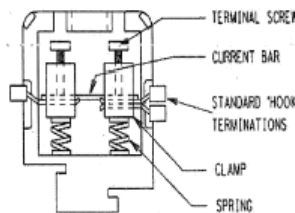
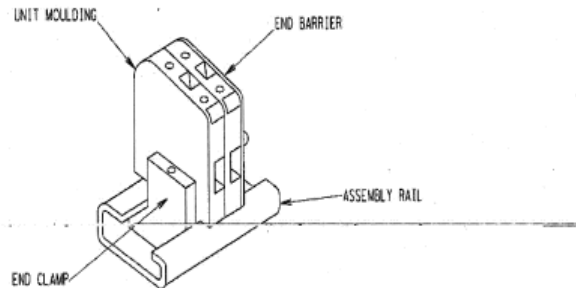

NOTE: SCREWDRIIVER ENTRIES TO BE NOT LESS THAN 4 mm DIAMETER

ESKOM DRG No 0.54/4369 sh 10

Figure 10: Spring-loaded terminal blocks

Terminal screws shall be captive within the mouldings and the heads shall not project above the moulding when fully released. Each terminal shall accept up to two hooked blade type terminations

Terminal entries shall be shrouded such that no current carrying metal is exposed when hooked blade terminations are fitted.

Springs shall be aged and shall withstand corrosion which might affect performance during their working life. Springs shall not carry current.

Cross connection facilities shall be provided for common-ing two or more adjacent terminal blocks, without interfering with the terminal openings.

**ESKOM COPYRIGHT PROTECTED**

## **34. Documentation**

All documentation and drawings must be in English.

Drawings, Photographs, Instruction Books, and Test Reports-As listed below shall be sent to Eskom. All drawings shall include the following information: Eskom, Serial Number, Design Fault Levels, gravitational force design limits, Power Ratings, Voltage Ratio, and Eskom Purchase Order Number.

Two (2) copies of outline, nameplate, base, bushings, schematics and complete wiring diagrams, terminal block arrangement drawings showing physical locations with dimensions are to be submitted for approval. The nameplate, schematic and wiring diagrams shall be submitted one month after the receipt of Purchase Order. The remaining drawings shall be submitted together a minimum of 8 months prior to delivery. The base drawings shall indicate the dimensions, jacking points, load bearing surfaces, and approximate total weight to facilitate the customer's foundation design. Purchaser shall return one copy of each drawing with comments or approval. All approved drawings are to be submitted in paper and in a CD. A late drawing penalty shall be assessed according to the schedule A of the specification.

Four (4) Photographs of the core and coil assembly shall be taken at such angles as to provide the maximum of design and construction information for records.

Quality Control Information-after an order has been, a copy of the manufacture quality control manual will be provided upon request to Eskom for their review.

Two (2) complete transformer manuals shall be delivered with the transformer. The manual shall be easily accessible and protected from moisture / water damage during transport and storage. This manual shall be used for erection and commissioning purposes and shall include the factory test results and diagrams.

A further two (2) manuals and one (1) electronic copy on CD shall be delivered not later than 14 days after completion of all commissioning tests. This manual shall include the electrical results from the commissioning testing carried out on site as well as testing done during transport. All oil sample results from tankers and main tank shall also be included.

## **35. Design Review Meeting**

No transformer shall be manufactured without a design review and acceptance of design on tenders issued with this specification. Where approved designs exist they should be submitted with the tender returns.

Acceptance of Eskom of the design does not relieve the OEM from their obligation to supply a safe and fully functional unit.

The design review shall be done following the guidelines Cigre TB – 204 for conducting design reviews for transformers.

A design review meeting is required before procurement of any materials or manufacturing proceeds. The purpose of the design review is to allow Eskom to understand the basic design, construction and installation of the transformer.

The manufacturer shall design the transformer in order that it performs satisfactory under all service conditions specified above.

The manufacture has to demonstrate that all the decisive design parameters are well within the manufacturer design limits, or relevant limits specified in standards or international criteria.

Eskom reserves the right to reject the design when manufacture fails to demonstrate the capability for design and manufacturing the transformer under review. This can happen when the presented design does not meet international accepted criteria and the manufacturer cannot prove his design by previously tested transformers of the same concept and voltage class.

The manufacture shall provide as minimum, information on the design of the magnetic circuit, windings, leads and insulation structure and provide a description of the proposed bushings and major accessories. The manufacturer shall provide information on through fault design, dielectric stress in all regions, thermal design including overload capabilities and all manufacturing processes.

All information must be submitted to the Eskom Project Manager two weeks prior to the design review, to allow Eskom to understand the design prior to the design review meeting.

The manufacture shall inform Eskom six weeks prior to the design review. All the discussions and final decisions taken during the design review must be minuted and be submitted to the Eskom project manager.

## **36. Losses**

### **36.1 Guaranteed Losses**

The manufacture shall guarantee that the transformer losses shall meet the requirements of SANS 780 and be equal to or lower than the loss levels quoted in Table 1 of SANS 780 as a minimum.

### **36.2 Non-Conformance**

If the measured no-load losses and/or load losses exceed the specified IEC tolerances Eskom reserves the right to reject the transformer.

### **36.3 Loss EVALUATION**

The following capitalisation formula will be used in the tender evaluation to provide a commercial incentive for lower loss designs.

$$Total\ cost = A + NLLF \times P_{NL} + LLF \times P_{LL}$$

where:

A = Cost of purchasing the transformer, R

$P_{NL}$  = No-load losses, kW

$P_{LL}$  = Load loss, kW

NLLF = No-load Loss Factor, R/kW

LLF = Load Loss Factor, R/kW

The economic life of a transformer is assumed to be 25 years.

The loss factors are calculated in accordance with Eskom technical bulletin 10TB-018 **Error! Reference source not found..**

Two sets of loss factors are used as indicated in 7, the actual values will be updated annually and will appear in the enquiry document.

a) Loss factors

**Table 7: Indication of loss factors**

<b>1</b>	<b>2</b>	<b>3</b>
Loss Factors	NLLF [R/kW]	LLF [R/kW]
Cost of distribution	NLLF <sub>DX</sub>	LLF <sub>DX</sub>
Long run marginal cost of generation	NLLF <sub>GX</sub>	LLF <sub>GX</sub>

Regardless of the use of the capitalization formula, the losses shall not be greater than those given in SANS 780. The details of which factors are used and when will be detailed in the enquiry document.

## **37. Quality Assurance**

All requirements of QM58 apply.

Eskom or the representative reserves the right to inspect the materials, equipment manufacture and witness the tests. The manufacture shall allow access to the Transmissions representative without any hindrance or additional charges to the Transmission. The Manufacture shall notify Eskom at least 8 weeks prior to commencement of the tests.

The Manufacturer shall submit a schedule within four weeks of the award of the contract.

This shall show dates for:

- Engineering and Design preparations
- Submit transformer Outline drawing to allow foundation design
- Submit Drawings, auxiliary component datasheets and Transformer Design for approval
- Supply of Instruction Manuals
- Purchasing and Delivery of Components
- Manufacturing and Assembly
- Testing of Transformer
- Shipment to Site

If a unit fails under test, the supplier will officially notify Eskom in writing within 24 hours of the failure, the contractor will set up a meeting with the employer to discuss and agree on a way forward. The contractor will supply a written report on the root cause of the failure within 14 days of the failure.

## **38. Local Technical Support**

Potential transformer suppliers shall have an established local technical support base. A Supervisor from the Contractor shall be available on site within 24 hours of notification of an emergency by the Purchaser.

The supplier shall be fully equipped to attend to emergencies and equipment failures within the guarantee period of the transformer.

### **38.1 Support requirements**

Local technical support shall cater for:

- Emergency breakdowns
- Failure investigations
- Maintenance & breakdown spares
- Operational enquiries
- Training

### 39. Authorization

This document has been seen and accepted by:

Name and surname	Designation
B Ntshangase	Power Delivery Engineering (High Voltage Plant PDE Senior Manager, Chairman of SCOT Electrical Plant Technical Committee)
S Mtetwa	Corporate Specialist – Transformers and Reactors, Chairman of Transformers and Reactors equipment care group
L Jordaan	Senior Consultant Transformers – Fleet Technology Generation Business Engineering
Peter Busch	Senior Consultant
Nkosinathi Buthelezi	Senior Consultant (Transformers and Reactors HV PDE)
Michael Ngubane	Senior Technologist (Transformers and Reactors HV PDE)
Calvin Bongwe	Senior Technologist (Northern grid)
Willie Liebenberg	Senior Advisor (Freestate grid)
Andries Smit	Senior Advisor (Western grid)
Wessel Benecke	Work Manager (Rotek)
Retief Snyman	Senior Advisor (Quality)
Goldstone Mungwe	Engineer (Generation Engineering)
Kevin Bosch	Quality Engineering
Nad Moodley	Chief Engineer (Peaking Generation)
Mpumelelo Khumalo	Chief Engineer (Generation Engineering)
Annalie Lombard	Corporate Specialist (RT&D)
Vuyile Kula	Senior Advisor (Southern Grid, WG Leader)
B J Ramcharan	Senior Advisor (Dx , KZN operating unit)
Steven Da Silva	Senior Advisor (Dx Commodity Sourcing)
Adesh Singh	Chief Engineer (Transformer and Reactors HV PDE)
Bheki Ntshangase	Grid Manager - North East Grid (SCOT PE SC Chairperson)
Thinus Du Plessis	Chief Engineer - HV Plant PDE

## 40. Revisions

Date	Rev.	Compiler	Remarks
Nov 2014	3	C P Wolmarans	<p>Due to BPP spec was revised with the following changes:</p> <p>Various Formatting and Spelling corrections</p> <p>Correction of references</p> <p>Section 3 - changed temperatures for yearly average ambient to be 25<sup>o</sup>C</p> <p>Section 5.1 Figure 1 – Corrected the neutral position</p> <p>Section 5.2.1 Table 1 clearances were changed to be in line with SANS 780 but 10% higher.</p> <p>Section 6 - Allowance for Porcelain bushings was added</p> <p>Section 7 Table 3 the following insulation levels were changed:</p> <p>Un-400V – 60s value changed to 8kV from 2.5kV.</p> <p>Un-11 &amp; 15kV – BIL &amp; 60s value changed to 150kV &amp; 50kV from 200kV &amp; 70kV.</p> <p>Section 7 Table 4 the following insulation levels were changed:</p> <p>Un-400V – 60s value changed to 8kV from 2.5kV.</p> <p>Section 10.1 – removed the requirement for step lap core.</p> <p>Section 11.1 – added section for conditions to allow aluminium conductors.</p> <p>Section 13 table 5 – changed Lightning Impulse Test for Chop to be Type and Full-Wave to be Routine.</p> <p>Section 13.4 to 13.8 – Updates the temperature rises to cater for a 25 degree ambient. Namely 55 rise for oil, 60 rise for winding and 73 for hot spot.</p> <p>Section 20, 21, 23 – added that single contacts are needed not dual as per the component specs.</p>
Aug 2013	2	C P Wolmarans for SCOT WG under Vuyile Kula	Amalgamation of standards across divisions and updating of specification.
July 2012	1	TDAC team	Document was moved into new template and re-signed from original TSP 41-121.

## 41. Development team

The following people were involved in the development of this document:

- Vuyile Kula
- Carl Wolmarans
- Andries Smit
- Willie Liebenberg

**ESKOM COPYRIGHT PROTECTED**

- Roger Cormack
- Keri Bromfield
- Sidwell Mtetwa
- Adesh Singh

## **42. Acknowledgements**

Not applicable.



### Annex A – Typical A/B Schedule

NOTE: FOR EACH TRANSFORMER SIZE AND DESIGN FOR THE SHADED VALUES (SUCH AS PRIMARY TERMINAL TYPE, VOLTAGE , KVA AND DIELECTRIC RATINGS) VALUES IN THE A COLUMN MUST BE INSERTED ACCORDINGLY, WHICH MUST CONFORM TO THE REQUIREMENTS SET OUT IN THIS SPECIFICATION.

Technical Schedules A and B for an Auxiliary Transformer

POWER RATING: \_\_\_\_\_ VOLTAGE RATING - PRIMARY: \_\_\_\_\_ SECONDARY: \_\_\_\_\_

VECTOR GROUP: \_\_\_\_\_ PRIMARY TERMINAL TYPE: \_\_\_\_\_

Schedule A: Purchasers specific requirements

Schedule B: Guarantees and technical particulars of equipment offered

Schedule Ref Number:

1	2	3	4	5
Item	Relevant Section(s)	Description	Schedule A	Schedule B
1		Purchasing details		
1.1		<input type="checkbox"/> Quantity of units required		
1.2		<input type="checkbox"/> SAP No		XXXXXXXXXX
1.3		<input type="checkbox"/> Region		XXXXXXXXXX
1.4		<input type="checkbox"/> Site Name		
1.5		<input type="checkbox"/> Nearest Town		
1.6		<input type="checkbox"/> Province		
1.7		<input type="checkbox"/> Distance from nearest town km		XXXXXXXXXX
1.8		<input type="checkbox"/> Access to site		XXXXXXXXXX
2		Delivery and off-loading		
2.1	27	<input type="checkbox"/> Transformer delivered to:		XXXXXXXXXX
2.2	26	<input type="checkbox"/> Delivery effected not before Date		XXXXXXXXXX
2.3	26,27	<input type="checkbox"/> Off-loaded from transport vehicle and transferred to intended operating position by supplier.	Yes	
2.4		<input type="checkbox"/> Distance from off-loading position m	0.0	
2.5		<input type="checkbox"/> Rise or fall to off-loading position mm	500.0	
2.6		<input type="checkbox"/> Acceleration limit in any direction g	XXXXXXXXXX	
2.7	26.2	<input type="checkbox"/> Impact recorder fitted	YES, on tank	

**ESKOM COPYRIGHT PROTECTED**

1	2	3	4	5
Item	Relevant Section(s)	Description	Schedule A	Schedule B
3	28	Erection and oil filling		
3.1	28.1	<input type="checkbox"/> Erected ready for service	Yes	
3.2		<input type="checkbox"/> Erection completed no later than _____ Date	TBA on order	
3.3	28.2	<input type="checkbox"/> Foundation Tolerances and layout	25 MPa rating, Submit information	
3.4	28.3, 28.4, 28.5	<input type="checkbox"/> On site functional and electrical tests	YES, as per sections 28.4-28.5	
4		Electrical Conditions		
4.1		<input type="checkbox"/> a) Nominal system voltage (Un) HV kV		XXXXXXXXXX
4.2		<input type="checkbox"/> b) Maximum system voltage (Um) HV kV		XXXXXXXXXX
4.3	4.1	<input type="checkbox"/> c) Nominal frequency Hz	50	XXXXXXXXXX
5	13.2	Type test certificates and typical test report to be submitted with tender	Yes	
6	13	Temperature rises at altitude of 1 800 m (on tap with highest current)		
6.1	13.7	<input type="checkbox"/> Top oil °K	55	
6.2	13.5	<input type="checkbox"/> Windings (by resistance) °K	60	
6.3	13.6	<input type="checkbox"/> Hotspot of winding °K	< 73	
6.4	13.8	<input type="checkbox"/> Hotspot of metal parts in contact with oil during any operating conditions and during overload test of 130% for 1 hour or 120% for 2 hours. °K	< 105	
7	13, Table 5	Tests		
7.1	13, Table 5	<input type="checkbox"/> Temperature rise tests on one unit and heat run (Type) see point 6	YES, TYPE	
7.2	13, Table 5	<input type="checkbox"/> Lightning Impulse test , full wave and chopped wave tests (test levels as per point 22)	FULL WAVE: ROUTINE, CHOP: TYPE	

ESKOM COPYRIGHT PROTECTED

1	2	3	4	5
Item	Relevant Section(s)	Description	Schedule A	Schedule B
7.3	13, Table 5	<input type="checkbox"/> Short Duration Induced (no PD measurement, test levels as per point 22 )	YES, ROUTINE	
7.4	13, Table 5	<input type="checkbox"/> Separate Source (test levels as per point 22)	YES, ROUTINE	
7.5	13, Table 5	<input type="checkbox"/> Short-circuit withstand tests	YES TYPE and PLEASE PROVIDE CALCULATIONS TO PROVE SHORT CIRCUIT CAPABILITY	
7.6	13, Table 5	<input type="checkbox"/> Insulation resistance to earth (Megger)	YES, ROUTINE	
7.7	13, Table 5	<input type="checkbox"/> Winding Resistance	YES, ROUTINE	
7.8	13, Table 5	<input type="checkbox"/> Ratio, voltage and phase displacement and vector group tests	YES, ROUTINE	
7.9	13, Table 5	<input type="checkbox"/> Impedance tests	YES, ROUTINE	
7.10	13, Table 5	<input type="checkbox"/> Pressure tightness tests	YES, ROUTINE	
7.11	13, Table 5	<input type="checkbox"/> Load and No-Load loss tests	YES, ROUTINE	
7.12	13, Table 5	<input type="checkbox"/> Sound level tests (see point 20)	YES, TYPE	
7.13	13, Table 5	<input type="checkbox"/> DGA in oil, kV and Moisture tests	YES, ROUTINE	
7.14	13, Table 5	<input type="checkbox"/> Appearance, construction and dimensions checks	YES, ROUTINE	
7.15	13, Table 5	<input type="checkbox"/> Dielectric loss angle test and capacitance of winding and SFRA	YES, ROUTINE	
7.16	13, Table 5	<input type="checkbox"/> Functional tests on all auxiliary components	YES, ROUTINE	
	13.2	(Note - Provide a typical detailed test plan)		
8		Continuous rated power for all tappings		
8.1	18	<input type="checkbox"/> cooling: ONAN kVA		

1	2	3	4	5
Item	Relevant Section(s)	Description	Schedule A	Schedule B
9		Nominal system voltage ( $U_n$ ) and rated voltage on principal tapping		
9.1		<input type="checkbox"/> Primary kV r.m.s		
9.2		<input type="checkbox"/> Secondary kV r.m.s		
9.3		<input type="checkbox"/> <b>b)</b> Maximum voltage for which system equipment is designed "Um" kV phase to phase HV kV		
9.4	25, 29 ,30	<input type="checkbox"/> i) Alarm Signalling DC Volts	All auxiliary contacts capable of 220 VDC @ 1A minimum	
9.5	25, 29 , 30	<input type="checkbox"/> ii) Tripping DC Volts	All auxiliary contacts capable of 220 VDC @ 1A minimum	
10		Voltage tapping range of Primary/Secondary ratio (% of the ratio on the principal tapping):		
10.1	12.2	<input type="checkbox"/> Max %	105	
10.2	12.2	<input type="checkbox"/> Min %	95	
10.3	12.2	<input type="checkbox"/> Size of steps %	2.5	
10.4	12.2	<input type="checkbox"/> Number of positions (including transition positions)	5	
11		Resulting no-load voltage appearing having LV constant		
11.1	12.2	<input type="checkbox"/> On principal tapping kV		
11.2	12.2	<input type="checkbox"/> On extreme plus tapping kV		
11.3	12.2	<input type="checkbox"/> On extreme minus tapping kV		
12		Transformer Type		
12.1		<input type="checkbox"/> Vector Group	Dyn11	
12.2		<input type="checkbox"/> Type of transformer	CORE	
12.3		<input type="checkbox"/> Number of limbs	3	
12.4	18.2	<input type="checkbox"/> Type of cooling	ONAN	

ESKOM COPYRIGHT PROTECTED

1	2	3	4	5
Item	Relevant Section(s)	Description	Schedule A	Schedule B
13	3	Operating environment		
13.1	16.3	<input type="checkbox"/> Corrosion protection	Yes paint must comply to 240-56030674	
13.2	3	<input type="checkbox"/> Maximum Ambient Temperature °C	+ 40	
13.3	3	<input type="checkbox"/> Average Ambient Temperature °C	+ 25	
13.4	3	<input type="checkbox"/> Minimum Ambient Temperature °C	- 10	
13.5	3	<input type="checkbox"/> Pollution level	Very Heavy	
13.6	3	<input type="checkbox"/> Solar Radiation kW/m <sup>2</sup>	1.2	
13.7	3	<input type="checkbox"/> Maximum operating Altitude above sea level	1800m	
14		Tank/Conservator Construction and Valves		
14.1	16.1	<input type="checkbox"/> Tank Material	Mild steel	
14.2	16.1	<input type="checkbox"/> Tank Cover	Bolted and gasketed	
14.3	16.1	<input type="checkbox"/> Vacuum Withstand of tank and fittings	Full vacuum at sea level	
14.4	16.1	<input type="checkbox"/> Bushing removal without removing top cover	Yes	
14.5	16.2	<input type="checkbox"/> Dye-penetrant tests on all welds	Yes	
14.6	16.3	<input type="checkbox"/> Corrosion protection (paint)	Must comply with 240-56030674	
14.6.1	16.3	<input type="checkbox"/> c) Tank colour	As 240-56030675	
14.6.2	16.3	<input type="checkbox"/> d) Conservator colour	as per 240-56030675	
14.7	16.7	<input type="checkbox"/> Fasteners:		
14.8	16.7	<input type="checkbox"/> All Bolts/studs	316 Stainless Steel	
14.9	16.7	<input type="checkbox"/> All nuts/washers	304 Stainless Steel	
14.10	16.8.3	<input type="checkbox"/> Tank Base thickness	> 10 mm	
14.11	16.8.4	<input type="checkbox"/> Partial drain indication level on tank	YES	
14.12	16.9	<input type="checkbox"/> Lifting lugs, Four symmetrically placed	YES	

ESKOM COPYRIGHT PROTECTED

1	2	3	4	5
Item	Relevant Section(s)	Description	Schedule A	Schedule B
14.13	16.1	<input type="checkbox"/> Hand Holes, for installation of bushing	YES	
14.14	16.12	<input type="checkbox"/> Bleeding Points	Stainless Steel DIN 42 558	
14.15	16.13	<input type="checkbox"/> Earthing Cleats provided for 50mm x 3mm Copper Straps	YES	
14.16	16.13	<input type="checkbox"/> Earthing Pads: at least one not higher than 100mm from tank base	YES	
14.17	17	<input type="checkbox"/> Conservator tank construction	Meet all requirements of section 17	
14.18	19.1	<input type="checkbox"/> Drain valve at lowest point:		
14.18.1	19.1	<input type="checkbox"/> a) Type	Gate valve, Brass	
14.18.2	19.1	<input type="checkbox"/> b) Bore	25mm	
14.18.3	19.1	<input type="checkbox"/> c) Make	xxxxxxxxxxxxx	
14.19	19.2	<input type="checkbox"/> Conservator Isolating Valve	Yes, double-flanged gate valve	
14.19.1		<input type="checkbox"/> a) Type	xxxxxxxxxxxxx	
14.19.2		<input type="checkbox"/> b) Bore	xxxxxxxxxxxxx	
14.19.3	19.2	<input type="checkbox"/> Conservator drain valve (at lowest point)	YES, 25mm gate valve	
14.2	22	<input type="checkbox"/> Oil sample point from Buchholz mounted at ground level	YES, meet all requirements of section 22	
15	11	Winding Design		
15.1	11.1	<input type="checkbox"/> Material		
15.1.1	11.1	<input type="checkbox"/> a) HV Winding	Copper Conductors (to consider Aluminium see 11.1)	
15.1.2	11.1	<input type="checkbox"/> b) LV Winding	Copper or Aluminium Foil or Copper conductors	

1	2	3	4	5
Item	Relevant Section(s)	Description	Schedule A	Schedule B
15.2	11.5	<input type="checkbox"/> Winding joints and internal connection	Must meet requirements of section 10.5	
15.3	11.6	<input type="checkbox"/> Short circuit capability	YES as per section 10.6	
15.4	11.7	<input type="checkbox"/> Sizing and Compression of winding	Tolerance -0 +2mm	
16	33	Transformer losses (Note - No plus tolerance allowed)		
16.1		<input type="checkbox"/> No load losses kW	xxxxxxxxxxx	
16.2		<input type="checkbox"/> @ 90% kW	xxxxxxxxxxx	
16.3		<input type="checkbox"/> @ 100% (This value will be used in financial evaluation) kW	xxxxxxxxxxx	
16.4		<input type="checkbox"/> @ 110% kW	xxxxxxxxxxx	
16.5		<input type="checkbox"/> Load losses kW	xxxxxxxxxxx	
16.6		<input type="checkbox"/> Extreme Plus @ rated current kW	xxxxxxxxxxx	
16.7		<input type="checkbox"/> Nominal @ rated current kW	xxxxxxxxxxx	
16.8	33.3	<input type="checkbox"/> Extreme Minus @ rated current kW  (Note: Loss evaluation will be performed using the average of the above three values)	xxxxxxxxxxx	
17	10	Core design		
17.1	10	<input type="checkbox"/> Maximum flux density @ $U_n$ Tesla	< 1.72	
17.2	10	<input type="checkbox"/> Insulation of Core DC	withstand 1000 V for 60 seconds	
		see Design schedule, it must be filled in line with section 9's general requirements		
18		Primary / Secondary impedance at 75 °C at rated kVA		
18.1		<input type="checkbox"/> On principal tapping %		
18.2		<input type="checkbox"/> On extreme plus tapping (maximum impedance) %		
18.3		<input type="checkbox"/> On extreme minus tapping (minimum impedance) %		

ESKOM COPYRIGHT PROTECTED

1	2	3	4	5
Item	Relevant Section(s)	Description	Schedule A	Schedule B
19		Primary / Secondary tolerances applicable to guaranteed impedances		
19.1		<input type="checkbox"/> On principal tapping	xxxxxxxxxxxxx	
19.2		<input type="checkbox"/> On extreme plus tapping	xxxxxxxxxxxxx	
19.3		<input type="checkbox"/> On extreme minus tapping (plus tolerance / minus tolerance)	xxxxxxxxxxxxx	
20	13.9	Maximum acoustic noise dB(A)	As per Table 6 of SANS 780	
21		Mechanical bracing of windings	NO	
22		Minimum insulation for windings		
22.1	7	Impulse withstand test voltage for line terminal:		
22.1.1	7	<input type="checkbox"/> Primary kV peak		
22.1.2	7	<input type="checkbox"/> Secondary kV peak		
22.2	7	Sixty-second, separate source		
22.2.1	7	<input type="checkbox"/> Primary kV r.m.s		
22.2.2	7	<input type="checkbox"/> Secondary kV r.m.s		

**ESKOM COPYRIGHT PROTECTED**



1	2	3	4	5
Item	Relevant Section(s)	Description	Schedule A	Schedule B
22.3	7	Sixty-second, induced-overvoltage withstand test voltages		
22.3.1	7	<input type="checkbox"/> Primary to earth kV r.m.s		
22.3.2	7	<input type="checkbox"/> Secondary kV r.m.s		
22.4		Inter-turn winding insulation		
22.4.1	11.1	<input type="checkbox"/> Paper/ Enamel	xxxxxxxxxxxx	
22.4.2	11.1	<input type="checkbox"/> Enamel grade	grade 3 or better	
22.4.3	11.1	<input type="checkbox"/> Paper thickness	xxxxxxxxxxxx	
22.4.4	11.4	<input type="checkbox"/> Highest inter-layer stress in non-tap part of winding kV/mm	< 5	
22.4.5	11.4	<input type="checkbox"/> Highest inter-layer stress in tap part of winding kV/mm	< 5	
23		<input type="checkbox"/> Primary Terminal Type – In the A schedule column it must be indicated if primary terminal shall be a bushing (23 A applicable) or cable box (23 B applicable, in each case the other section must be ignored.		
23 A		Main terminals & Bushing		
23.1 A		<input type="checkbox"/> Type	Outdoor	
23.2 A	5.2.1, 6	<input type="checkbox"/> Details of Primary bushing / terminal		
23.2.1A	6	Shed material	Composite/ Porcelain	
23.2.2A	6	<input type="checkbox"/> Make & Model & Type	xxxxxxxxxxxx	
23.2.3A	6	<input type="checkbox"/> Stem size (dia x length) mm	26 x 125	
23.2.4A	6	<input type="checkbox"/> Rated Voltage kV		
23.2.5A	6	<input type="checkbox"/> Current Rating (incl 30% overcurrent) A	xxxxxxxxxxxx	
23.2.6A	6	<input type="checkbox"/> Impulse withstand voltage at sea level kV peak		

1	2	3	4	5
Item	Relevant Section(s)	Description	Schedule A	Schedule B
23.2.7A	6	<input type="checkbox"/> Power frequency withstand voltage kV r.m.s		
23.2.8A	6	<input type="checkbox"/> Creepage (31mm/kV) mm		
23.2.9A	6	<input type="checkbox"/> Protected Creepage mm	xxxxxxxxxxxx	
23 B		Main terminal - Primary Cable Box/Enclosure		
23.1 B		<input type="checkbox"/> Type	Cable Enclosure	
23.2 B	5.2.2	<input type="checkbox"/> Details of Primary Cable Box / terminal	Must meet requirements of 5.2.2	
23.2.1B	5.2.2	<input type="checkbox"/> Type	xxxxxxxxxxxx	
23.2.2B	5.2.2	<input type="checkbox"/> Make & Model & details	Submit drawings and datasheets	
23.2.3B	5.2.2	<input type="checkbox"/> Rated Voltage kV		
23.2.4B	5.2.2	<input type="checkbox"/> Current Rating (incl 30% overcurrent) A	xxxxxxxxxxxx	
23.2.5B	5.2.2	<input type="checkbox"/> Impulse withstand voltage at sea level kV peak		
23.2.6B	5.2.2	<input type="checkbox"/> Power frequency withstand voltage kV r.m.s		
23.2.7B	5.2.2	<input type="checkbox"/> Cable Type and details	Submit details	
24		<input type="checkbox"/> Secondary Terminal		
24.1.1	5.2.2	<input type="checkbox"/> Type	Cable Box, provide drawing	
24.1.2	5.2.3	<input type="checkbox"/> LV Cable box/encloure	Must meet all requirements of section 5.2.3	
24.1.3	5.2.4	<input type="checkbox"/> Circuit Breaker	Cable entry, moulded-case air circuit breaker, as per section 5.2.4	

1	2	3	4	5
Item	Relevant Section(s)	Description	Schedule A	Schedule B
24.1.4	5.2.4	<input type="checkbox"/> Current Rating (incl 30% overcurrent) A	xxxxxxxxxxx	
24.1.5	5.2.3	<input type="checkbox"/> Cable type	As per Table 2	
24.1.6	5.2.3	<input type="checkbox"/> Cable Cross-section as per Table 2 mm <sup>2</sup>	As per Table 2	
25		Physical arrangement		
25.1		<input type="checkbox"/> Maximum overall dimensions		
25.1.1		Height mm	xxxxxxxxxxxxx	
25.1.2		Length mm	xxxxxxxxxxxxx	
25.1.3		Width mm	xxxxxxxxxxxxx	
25.2		<input type="checkbox"/> Overall dimensions of tank only		
25.2.1		Base plate type (flat / prefabricated)	flat	
25.2.2		Length mm	xxxxxxxxxxxxx	
25.2.3		Base plate thickness mm	xxxxxxxxxxxxx	
26		Cooling equipment		
26.1	18	<input type="checkbox"/> Radiators		
26.1.1		Material Type (Cooler tubes / press sheet radiators)	xxxxxxxxxxx	
26.1.2		Material thickness mm	xxxxxxxxxxx	
27		Safe withstand vacuum at sea level kPa	xxxxxxxxxxxxx	
28		Transformer oil type	Must comply with Eskom Standard 240-75661431	
28.1		Manufacturer and type:	xxxxxxxxxxxxx	

1	2	3	4	5
Item	Relevant Section(s)	Description	Schedule A	Schedule B
29		Tap-changers		
29.1	12	<input type="checkbox"/> Type	Off-Circuit Tap Switch	
29.2	12	<input type="checkbox"/> De-Energised Tap-changer		
29.2.1		Manufacturer	xxxxxxxxxx	
29.2.3		Model Number	xxxxxxxxxx	
29.2.4		Precise electrical location of tappings	Provide drawings	
29.2.5		Diagrammatic arrangement shown on Drawing No.	xxxxxxxxxx	
29.3		<input type="checkbox"/> Nominal 50 Hz ratings of off circuit tap switch:		
29.3.1		Voltage kV	xxxxxxxxxxxxx	
29.3.2		Current A	xxxxxxx	
29.4		<input type="checkbox"/> Insulation levels of tap-changer		
29.4.1		phase-to-phase kV peak	xxxxxxxxxx	
29.5		<input type="checkbox"/> Tap-changer 50 Hz withstand		
29.5.1		phase-to-phase kV r.m.s	xxxxxxxxxxxxx	
30	31	Drawings & Manuals		
30.1		<input type="checkbox"/> Quantity of drawings per order	2	
30.2		<input type="checkbox"/> Quantity of Manuals (hard copy + electronic) per order	4 + 1	
30.3		<input type="checkbox"/> Quantity of Manuals and Drawings per Design submitted with tender	2	
31		Indicating and protective devices		
31.1	23	<input type="checkbox"/> Oil- and gas-actuated relay	Must comply with 240-56063908	
31.2	24	<input type="checkbox"/> Dehydrating breathers	Must comply with 240 - 56062529	
31.3	21	<input type="checkbox"/> Oil level indicators	Must comply with 240-56356191	

**ESKOM COPYRIGHT PROTECTED**

1	2	3	4	5
Item	Relevant Section(s)	Description	Schedule A	Schedule B
31.4	20	<input type="checkbox"/> Oil temperature thermometer	Must comply with 240-56063843	
32	35	<input type="checkbox"/> Local Technical Support	Yes, Provide details	
33	29, 30	<input type="checkbox"/> Secondary and auxiliary terminations and wiring	Must meet requirements of section 29 and 30	
34	25.3	<input type="checkbox"/> Current Transformers		
34.1	25.3	<input type="checkbox"/> CTs to be supplied (indicate YES/NO):	NO	
34.2	25.3	<input type="checkbox"/> Location/Type		
34.4	25.3	<input type="checkbox"/> Ratio		
34.5	25.3	<input type="checkbox"/> Accuracy class		
34.6	25.3	<input type="checkbox"/> Mag Curve drawing	Submit if CT required	
35		Spares recommended by manufacturer (Provide detailed list)		
		Note:		
		Submit all technical drawings including component lists and wiring diagrams		
		Submit datasheet of each of the auxiliary components eg. Buchholz Relay		





Design Parameter Schedules A and B for an Auxiliary Transformer

POWER RATING: \_\_\_\_\_ VOLTAGE RATING - PRIMARY: \_\_\_\_\_ SECONDARY: \_\_\_\_\_  
 VECTOR GROUP: \_\_\_\_\_ PRIMARY TERMINAL TYPE: \_\_\_\_\_

Schedule A: Purchasers specific requirements

Schedule B: Guarantees and technical particulars of equipment offered

1	2	3	4	5
Item		Description	Schedule A	Schedule B
1		Core Steel		
1.1		<input type="checkbox"/> Manufacturer of core steel	XXXXXXXXXX	
1.2		<input type="checkbox"/> Grade of core steel	XXXXXXXXXX	
1.3		<input type="checkbox"/> Thickness of core steel mm	XXXXXXXXXX	
2		Core dimensions		
2.1		<input type="checkbox"/> Window height [WH] mm	XXXXXXXXXX	
2.2		<input type="checkbox"/> Distance between core limb centres [CL] mm	XXXXXXXXXX	
2.3		<input type="checkbox"/> Core Diameter [D] mm	XXXXXXXXXX	
2.4		<input type="checkbox"/> Filling Factor	XXXXXXXXXX	
3		Cross sectional areas		
3.1		<input type="checkbox"/> Wound limbs mm <sup>2</sup>	XXXXXXXXXX	
3.2		<input type="checkbox"/> Yoke mm <sup>2</sup>	XXXXXXXXXX	
4		Total core mass kg	XXXXXXXXXX	
5		The design flux density at U <sub>n</sub> for:		
5.1		<input type="checkbox"/> Wound limbs T	XXXXXXXXXX	
5.2		<input type="checkbox"/> Yoke T	XXXXXXXXXX	
6		Volts/turn at the above flux densities V/turn	XXXXXXXXXX	

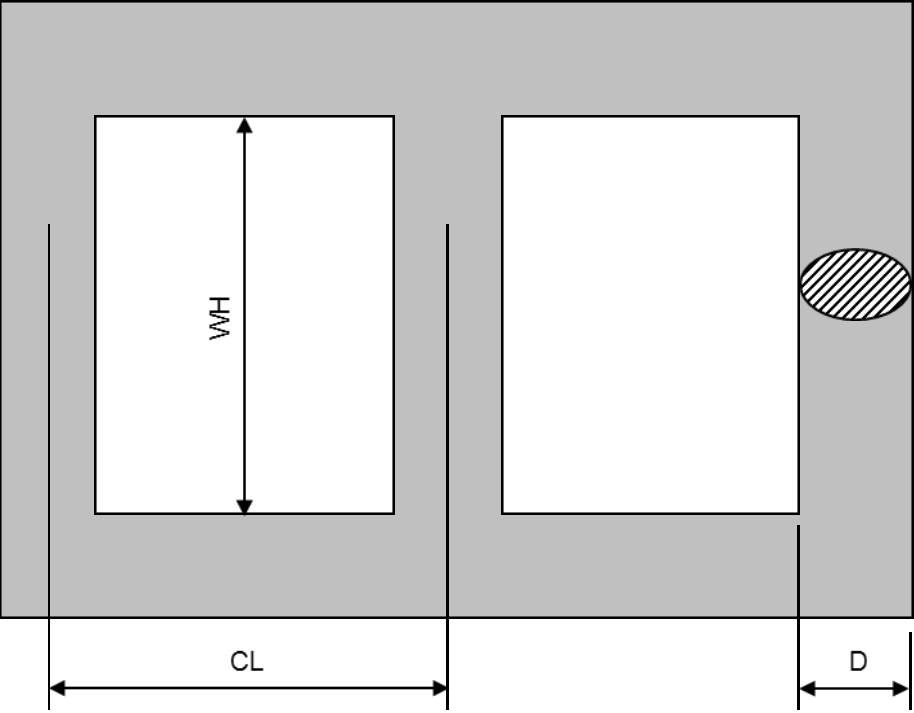

1	2	3	4	5
Item		Description	Schedule A	Schedule B
				
7		Winding design		
7.1		<input type="checkbox"/> Winding arrangement (CORE / LV / HV )	XXXXXXXXXX	
7.2		<input type="checkbox"/> Conductor Yield strength                      N/mm <sup>2</sup>	XXXXXXXXXX	
7.3		<input type="checkbox"/> Winding 1	LV	
7.3.1		Type (i.e. multilayer helix)	XXXXXXXXXX	
7.3.2		Lead type (End Fed / Centre Fed)	XXXXXXXXXX	
7.3.3		Number of turns	XXXXXXXXXX	
7.3.4		Inner Diameter                                      mm	XXXXXXXXXX	
7.3.5		Outer Diameter                                     mm	XXXXXXXXXX	
7.3.6		Radial build                                         mm	XXXXXXXXXX	
7.3.7		Magnetic height                                   mm	XXXXXXXXXX	
7.3.8		Conductor configuration	XXXXXXXXXX	
7.3.9		- Size	XXXXXXXXXX	
7.3.10		- Number	XXXXXXXXXX	

**ESKOM COPYRIGHT PROTECTED**

1	2	3	4	5
Item		Description	Schedule A	Schedule B
7.3.11		Conductor insulation mm	XXXXXXXXXX	
7.3.12		Current density A/mm <sup>2</sup>	XXXXXXXXXX	
7.3.13		Temperature gradient °C (K) winding – oil	XXXXXXXXXX	
7.3.14		Total conductor mass kg	XXXXXXXXXX	
7.4		<input type="checkbox"/> Winding 2	HV	
7.4.1		Type (i.e. multilayer helix)	XXXXXXXXXX	
7.4.2		Lead type (End Fed / Centre Fed)	XXXXXXXXXX	
7.4.3		Number of turns	XXXXXXXXXX	
7.4.4		Inner Diameter mm	XXXXXXXXXX	
7.4.5		Outer Diameter mm	XXXXXXXXXX	
7.4.6		Radial build mm	XXXXXXXXXX	
7.4.7		Magnetic height mm	XXXXXXXXXX	
7.4.8		Conductor configuration	XXXXXXXXXX	
7.4.9		- Size	XXXXXXXXXX	
7.4.10		- Number	XXXXXXXXXX	
7.4.11		Conductor insulation mm	XXXXXXXXXX	
7.4.12		Current density A/mm <sup>2</sup>	XXXXXXXXXX	
7.4.13		Temperature gradient °C (K) winding – oil	XXXXXXXXXX	
7.4.14		Total conductor mass kg	XXXXXXXXXX	
8		Inter-winding Insulation		
8.1		<input type="checkbox"/> CORE - LV winding	XXXXXXXXXX	
8.1.1		Number of barriers	XXXXXXXXXX	
8.1.2		Barrier thickness mm	XXXXXXXXXX	
8.1.3		Distance from windings mm	XXXXXXXXXX	
8.1.4		Distance between barriers mm	XXXXXXXXXX	
8.2		<input type="checkbox"/> LV winding to HV winding	XXXXXXXXXX	

1	2	3	4	5
Item		Description	Schedule A	Schedule B
8.2.1		Number of barriers	XXXXXXXXXX	
8.2.2		Barrier thickness mm	XXXXXXXXXX	
8.2.3		Distance from windings mm	XXXXXXXXXX	
8.2.4		Distance between barriers mm	XXXXXXXXXX	

General Information Schedule A and B for an Auxiliary Transformer

POWER RATING: \_\_\_\_\_ VOLTAGE RATING - PRIMARY: \_\_\_\_\_ SECONDARY: \_\_\_\_\_  
 VECTOR GROUP: \_\_\_\_\_ PRIMARY TERMINAL TYPE: \_\_\_\_\_

Schedule A: Purchasers specific requirements

Schedule B: Guarantees and technical particulars of equipment offered

Schedule Ref  
 Number:

1	2	3	4	5
Item		Description	Schedule A	Schedule B
1		Transformer general information		
1.1	<input type="checkbox"/>	Manufacturer	xxxxxxxxxx	
1.2	<input type="checkbox"/>	Place of manufacture	xxxxxxxxxx	
2		Oil quantities:		
2.1	<input type="checkbox"/>	Transformer tank	xxxxxxxxxx	
2.2	<input type="checkbox"/>	Tap-changer	xxxxxxxxxx	
2.3	<input type="checkbox"/>	Radiators	xxxxxxxxxx	
2.4	<input type="checkbox"/>	Conservator (Main & tap-changer)	xxxxxxxxxx	
3		Masses		
3.1	<input type="checkbox"/>	Mass of core steel kg	xxxxxxxxxx	
3.3	<input type="checkbox"/>	Total dry insulation mass kg	xxxxxxxxxx	
3.4	<input type="checkbox"/>	Total mass of active part kg	xxxxxxxxxx	
3.5	<input type="checkbox"/>	Mass of tank and fittings kg	xxxxxxxxxx	
3.6	<input type="checkbox"/>	Mass of coolers kg	xxxxxxxxxx	
3.7	<input type="checkbox"/>	Mass of oil kg	xxxxxxxxxx	
3.8	<input type="checkbox"/>	Greatest transportation mass kg	xxxxxxxxxx	
4		Primary / Secondary zero sequence impedances		
4.1	<input type="checkbox"/>	On principal tapping %	xxxxxxxxxx	
4.2	<input type="checkbox"/>	On extreme plus tapping %	xxxxxxxxxx	
4.3	<input type="checkbox"/>	On extreme minus tapping %	xxxxxxxxxx	

**ESKOM COPYRIGHT PROTECTED**

1	2	3	4	5
Item		Description	Schedule A	Schedule B
5		Primary / Neutral zero sequence impedances		
5.1	<input type="checkbox"/>	On principal tapping %	xxxxxxxxxxx	
5.2	<input type="checkbox"/>	On extreme plus tapping %	xxxxxxxxxxx	
5.3	<input type="checkbox"/>	On extreme minus tapping %	xxxxxxxxxxx	
6		Secondary / Neutral zero sequence impedances		
6.1	<input type="checkbox"/>	On principal tapping %	xxxxxxxxxxx	
6.2	<input type="checkbox"/>	On extreme plus tapping %	xxxxxxxxxxx	
6.3	<input type="checkbox"/>	On extreme minus tapping %	xxxxxxxxxxx	
7		Filling medium for transport	xxxxxxxxxxx	
8		Training of purchaser's staff		
8.1	<input type="checkbox"/>	Training provided on components	Yes	
8.2	<input type="checkbox"/>	Details provided of how training is going to be conducted on Eskom staff?	Submit information	

**ESKOM COPYRIGHT PROTECTED**